

Introduction

The IDT SGAS7xx line of solid-state chemiresistive gas sensors provide a cost-effective means of detecting several types of gases in atmospheres. The schematic for the sensors in the SGAS family is shown in Figure 1. The sensors consist of a high-resistance metal-oxide semiconductor element (R_S) and low-resistance heating element (R_H), each driven by control circuits as described in the SGAS7xx datasheets. While it is possible to design analog circuitry to regulate the heater drive and directly output the sensor signal as a voltage or current proportional to the sensor resistance, device designers often require a digitally controlled interface for operating the SGAS7xx sensor. This application note provides general guidance for developing an SGAS7xx digital interface, focusing on a low-cost implementation using a minimum number of components.

Figure 1. SGAS7xx Sensor Schematic

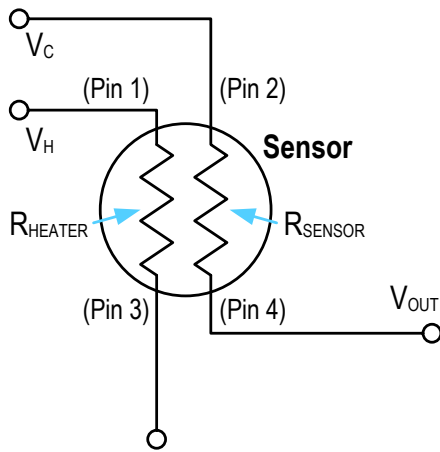

Overview

A block diagram of a functional digital system for the SGAS7xx sensor is shown in Figure 2. The analog front-end (AFE) contains circuitry that conditions signals between the SGAS7xx sensor and the microcontroller unit (MCU), and the “Power Conditioning” block represents circuitry that produces regulated power for the AFE and MCU. All control and measurement functionality resides in the MCU, which can be selected from the many low-cost 8-bit or 16-bit devices currently produced by microcontroller manufacturers. The remainder of this application note describes how the combined functionality of the blocks in Figure 2 provides measurement and control functionality for SGAS7xx sensors.

Figure 2. Block Diagram of an SGAS7xx Digital Interface

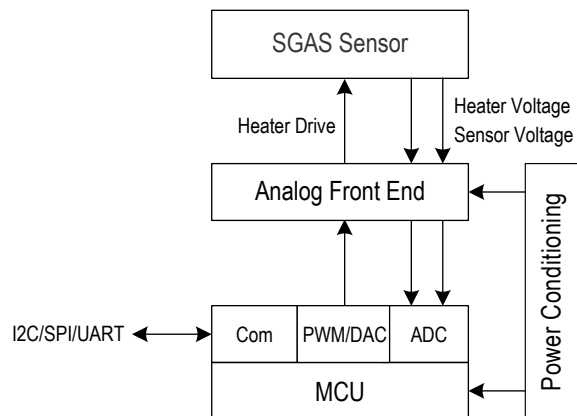

Heater Control

A fundamental characteristic of the SGAS7xx sensor heater is that like all resistive heater devices, heater resistance increases as applied power increases. Consequently, well-controlled heater operation requires heater drive circuitry that fixes one electrical drive parameter and controls by measuring another. The SGAS7xx datasheets describe methods of heater control that include constant voltage, constant current, and pulse-width modulation (PWM). All of the analog circuits associated with each of these methods produce an output voltage that can easily be monitored by an analog-to-digital converter (ADC), and all have some means of providing the relatively high current required to drive the sensor heater. If a known, fixed voltage is used to drive the sensor heater, then a three-terminal regulator can be used to drive the sensor heater. Monitoring the sensor voltage using the ADC functionality of the MCU is useful only in ensuring that the heater drive is operating at the correct voltage. Similarly, a known, fixed constant current can be used to drive the sensor heater. The advantage with this approach is that the MCU can calculate both the heater resistance and power from the combination of the known heater current and the measured heater voltage. While it is true that the same objectives could be achieved using a fixed-voltage heater drive in combination with a current measuring resistor, the fixed-current method produces a voltage output that is closer to the input requirements of most ADCs and uses fewer components to implement.

The fixed-current heater drive concept can be extended to variable-current drive using the circuit shown in Figure 3. This circuit produces a known current that is proportional to the input voltage V_{IN} . The MCU can produce V_{IN} using either a digital-to-analog converter (DAC) or a pulse-width modulation (PWM) output that is low-pass filtered to produce a constant voltage.

This allows great latitude in controlling the sensor heater:

- The heater can be set to operate at an operator-selectable constant current.
- The heater can be automatically adjusted to a constant voltage via MCU monitoring of the actual voltage on the heater.
- The heater can be automatically set to a constant power or constant resistance via MCU adjustment of the current * voltage product or voltage ÷ current quotient, respectively.
- The heater voltage, current, power, or resistance can be programmed in real time via a sequence from the MCU, including the case where the sensor heater is turned off for extended periods of time to reduce overall power consumption.

Figure 3. Voltage-Controlled Current Drive

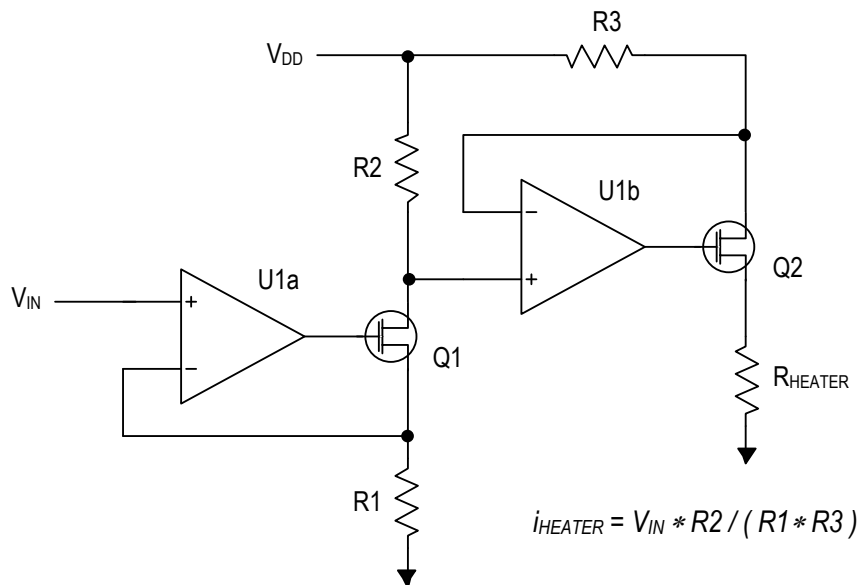

The recommended operating points for the heater voltage and current are specified in the SGAS7xx datasheets. In most cases, this voltage will be greater than the supply voltage to the MCU and to the sensor resistance measurement portion of the AFE circuitry. The power conditioning portion of the digital interface must supply this voltage, either directly from an external power supply or via a voltage multiplier. If the MCU is using the USB for external communications to the interface in combination with a sensor heater voltage below 4.5V, the 5V USB supply can be used as the sole power source.

If the circuit in Figure 3 is used to drive the sensor heater, the heater voltage measured by the MCU can be used in a feedback control loop to maintain the heater voltage, power, or resistance at a constant value. As an example, Figure 4 outlines an algorithmic method for maintaining an SGAS7xx sensor heater at a constant power using the known heater current and the measured heater voltage. The initial current should be set at a value lower than the anticipated final heater current so that overdriving the heater is avoided. The time constant of SGAS7xx sensor heaters to a step change in drive power is approximately 0.5s, so firmware heater control loops typically need to run no faster than 10Hz to maintain adequate heater control.

Figure 4. Method for Maintaining Constant Heater Power

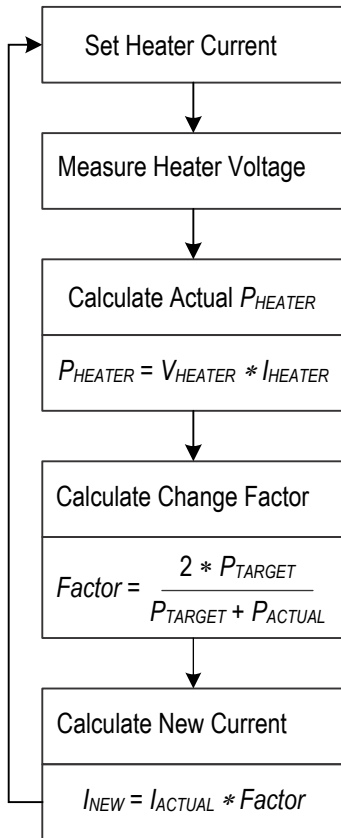

Resistance Measurement

The SGAS7xx sensors have sensor element resistances that vary widely according to operating temperature and sensor type. For any particular sensor, the resistance range extends across approximately 3½ magnitudes. Resistance measurements can be accomplished with a voltage divider in which the sensor element is the upper half of the divider or by applying a known voltage or current across the sensor element and measuring the resulting current or voltage respectively. Details of the measurement circuits and their relative advantages/disadvantages can be found in the IDT *Application Note AN-988 – Resistance Measuring Circuits for SGAS Sensors*.

The measurement of sensor resistance using a constant-current source in conjunction with direct measurement of the sensor voltage, as illustrated in Figure 5, is a particularly appealing choice for MCU-based measurement systems. Fixed-current sources are available as single ICs or may be constructed using discrete components. Since the sensor response ranges over a maximum of 3½ orders of magnitude, a single fixed-current source plus a 12-bit ADC is generally adequate for measuring sensor response in most applications. For an increased measurement range or a measurement accuracy at a particular measurement value, a circuit that supplies a settable fixed current, such as that of Figure 3, can be used to set an optimum measurement current.

Figure 5. Digital Measurement of Sensor Resistance

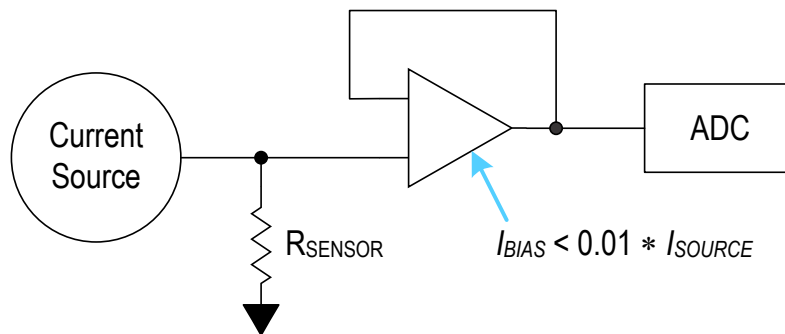

Conversion of Resistance to Concentration

SGAS7xx sensors show reduced sensor element resistance with increased gas concentration. The reduced resistance follows the relationship shown in Equation 1:

$$\log(R) = \log(A) - \alpha * \log(C) \tag{Equation 1}$$

Where

R is resistance

C is concentration

A and α are constants

Determination of A and α is accomplished through a calibration process, in which two or more known concentrations of gas are applied to a sensor operating under normal measurement conditions, followed by least-squared determination of the best-fit values of A and α . Gas concentrations are determined by solving Equation 1 for C , resulting in Equation 2:

$$C = 10^{\frac{\log(R/A)}{-\alpha}} \tag{Equation 2}$$

If the calibration constants A and α are known, calculation of the gas concentration from the measured resistance requires one power and one logarithm calculation per determination. Most MCU programming platforms have library functions available that enable these calculations in a relatively small amount of memory and processing time.

Constants A and α are highly dependent upon the temperature of the sensor and on the metal-oxide sensing material used for the sensor construction. The constants also vary slightly from sensor to sensor because of detailed surface morphology. For some applications, these sensor-to-sensor variances may be disregarded, allowing the use of a generic set of constants in producing a linearized resistance to concentration relationship. In applications that require a high precision, the determination of A and α on a sensor-by-sensor basis might be needed. Precision applications should also anticipate some amount of response drift with sensor aging, requiring re-calibration on a schedule commensurate with the application accuracy requirements.

External Communication

Most modern MCUs have one or more communication blocks that enable serial communication by I2C, SPI, or UART, with corresponding hardware and firmware support that significantly reduce both external component count and the coding burden. Low-cost, high-capability ICs that allow USB interconnectivity with the UARTs or the I2C ports on MCUs are available from several manufacturers. Collectively, these capabilities enable creation of standard digital communication channels to external devices such as PCs or industrial controllers with minimal effort.

Conclusion

A relatively simple but very effective digital interface can be designed and constructed for SGAS7xx sensors with a minimum number of components. Low cost 8-bit and 16-bit microcontrollers can be utilized to supply much of the functionality needed to make high quality, automated gas measurements with the SGAS7xx sensor line.

Revision History

Revision Date	Description of Change
November 29, 2017	Initial release.

IMPORTANT NOTICE AND DISCLAIMER

RENESAS ELECTRONICS CORPORATION AND ITS SUBSIDIARIES (“RENESAS”) PROVIDES TECHNICAL SPECIFICATIONS AND RELIABILITY DATA (INCLUDING DATASHEETS), DESIGN RESOURCES (INCLUDING REFERENCE DESIGNS), APPLICATION OR OTHER DESIGN ADVICE, WEB TOOLS, SAFETY INFORMATION, AND OTHER RESOURCES “AS IS” AND WITH ALL FAULTS, AND DISCLAIMS ALL WARRANTIES, EXPRESS OR IMPLIED, INCLUDING, WITHOUT LIMITATION, ANY IMPLIED WARRANTIES OF MERCHANTABILITY, FITNESS FOR A PARTICULAR PURPOSE, OR NON-INFRINGEMENT OF THIRD-PARTY INTELLECTUAL PROPERTY RIGHTS.

These resources are intended for developers who are designing with Renesas products. You are solely responsible for (1) selecting the appropriate products for your application, (2) designing, validating, and testing your application, and (3) ensuring your application meets applicable standards, and any other safety, security, or other requirements. These resources are subject to change without notice. Renesas grants you permission to use these resources only to develop an application that uses Renesas products. Other reproduction or use of these resources is strictly prohibited. No license is granted to any other Renesas intellectual property or to any third-party intellectual property. Renesas disclaims responsibility for, and you will fully indemnify Renesas and its representatives against, any claims, damages, costs, losses, or liabilities arising from your use of these resources. Renesas' products are provided only subject to Renesas' Terms and Conditions of Sale or other applicable terms agreed to in writing. No use of any Renesas resources expands or otherwise alters any applicable warranties or warranty disclaimers for these products.

(Disclaimer Rev.1.01 Jan 2024)

Corporate Headquarters

TOYOSU FORESIA, 3-2-24 Toyosu,
Koto-ku, Tokyo 135-0061, Japan
www.renesas.com

Trademarks

Renesas and the Renesas logo are trademarks of Renesas Electronics Corporation. All trademarks and registered trademarks are the property of their respective owners.

Contact Information

For further information on a product, technology, the most up-to-date version of a document, or your nearest sales office, please visit www.renesas.com/contact-us/.