

Putting Analog On The Bus

The objective of this application note is to (1) illustrate the idea of 'computerizing analog functions' and (2) provide the design engineer with reference designs for controlling the key parameters of analog circuits using digitally controlled potentiometers connected to a computer bus.

Basic Ideas

The computer has extended the capabilities of electronics products and systems by adding the power of high speed control, computation, and programmability at a very low cost. There are, however, applications where the compact, continuous signal analog circuits are still the preferred design approach. We can, however, have the best of both worlds if we combine the advantages of the computer with the advantages of the analog circuits. This can be done through a *Intersil digitally controlled potentiometer (XDCP)*; a *system level control device performing a component level function*. Figure 1 is a caricature depicting the idea of 'putting analog on the bus'. Figure 2 illustrates the idea of computerizing an analog function in block diagram form. If parameters of an analog function are varied using a potentiometer and if the potentiometer is computer controlled, then the parameters of the analog function are controlled using the computer's bus. The idea of 'putting analog on the bus' refers to varying one or more of an analog circuit's parameters through the use of the digitally controlled potentiometer connected to the computer bus. Any analog circuit whose parameters depend on a resistance is a candidate for application of a digitally

controlled potentiometer. The potentiometer can be configured as a two-terminal variable resistance or a three-terminal voltage divider. The mixed signal *XDCP provides variability through its analog potentiometer and programmability through its computer interface and bus*.

The key analog functions are amplification, regulation, filtering, oscillation, and conversion and the circuits which implement these functions are amplifiers, regulators, filters, oscillators, and converters. Representative examples of each of these circuits will illustrate the computerization of the analog functions.

- **Amplifiers:** *Customized Potentiometers Advance Amplifier Design*
- **Regulators:** *Programmable System-Level Voltage Regulator*
- **Filters:** *Tunable Bandpass (IGMF) Filter*
- **Oscillators:** *Digitally Controlled Potentiometer Programs the 555, Phase Shift Sinusoidal Oscillator*
- **Convertors:** *I to V Convertor*

These basic analog circuits are used as universal building blocks in the design of analog systems and they also serve as models for more specialized analog functions. The following collection of *independent articles and circuits* are examples of 'putting analog on the bus'. All of them have been breadboarded and tested.

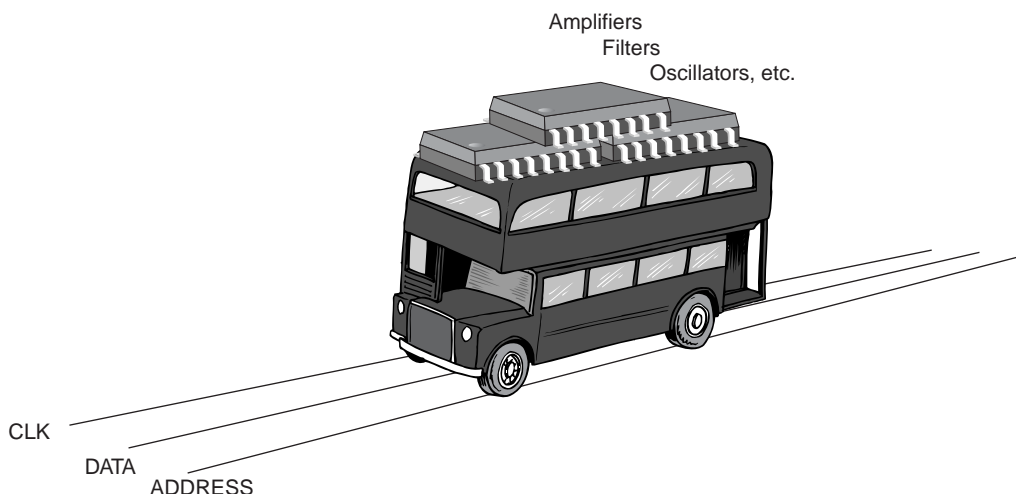

FIGURE 1. CARICATURE OF THE IDEA OF "PUTTING ANALOG ON THE BUS"

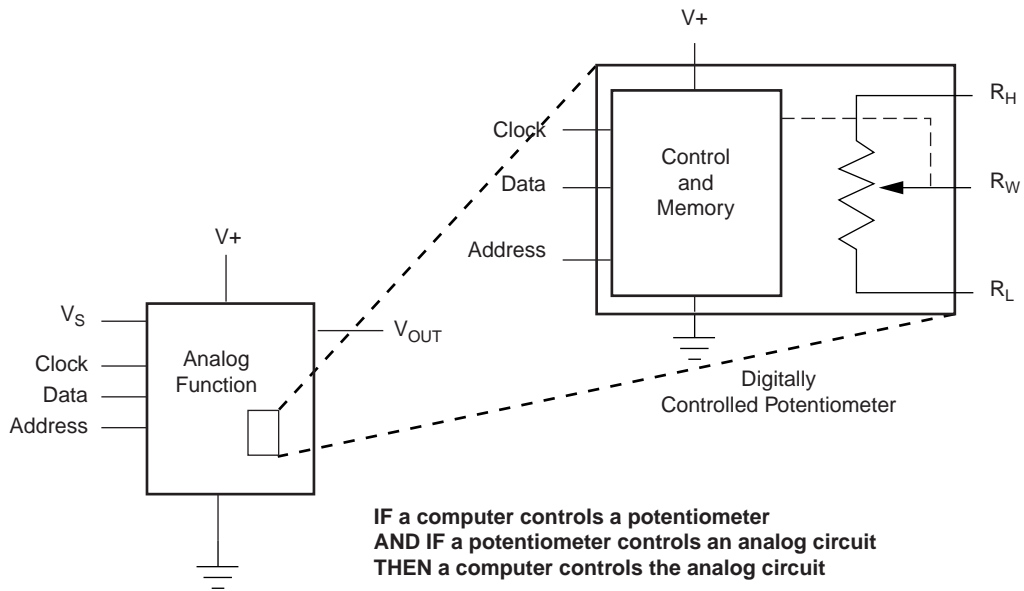

FIGURE 2. BLOCK DIAGRAM OF "COMPUTERIZING AN ANALOG FUNCTION"

Customized Potentiometers Advance Amplifier Design

The circuit in Figure 3 is a model of an amplifier circuit whose cutoff frequency and gain are changed using variable resistors. The cutoff frequency is established by a first-order, RC low pass filter and the gain is established by a traditional noninverting operational amplifier circuit. Variability and programmability are added to the circuit if digitally controlled potentiometers (XDCPs) are used to implement the variable resistors. The circuit in Figure 4 shows the implementation of the frequency and gain controls. The potentiometer R is configured as a pseudo-tee network and along with capacitor C establishes the upper cutoff frequency f_c . Potentiometer R_2 is used as a three-terminal device and establishes the voltage gain G_0 .

The voltage gain for the circuit has the form of

$$\frac{V_o}{V_s} = \frac{G_0 \omega_c}{j\omega + \omega_c}$$

G_0 is the programmable closed-loop passband gain

$$G_0 = \frac{R_1 + R_2}{R_1 + k_2 R_2} \quad 0 \leq k_2 \leq 1$$

where k_2 reflects the proportionate position of the wiper from one end of the pot (0) to the other end of the pot (1). The gain is programmable from 1 to $(R_1 + R_2)/R_1$. The fixed resistor R_1 limits the circuit's maximum voltage gain, a condition usually necessary for accuracy and bandwidth purposes.

The upper cutoff frequency f_c is established by the input R-C network

$$f_c = \frac{\omega_c}{2\pi} = \frac{1}{2\pi(k_1 R)C} \quad 0 \leq k_1 \leq 1$$

where k_1 (like k_2) reflects the proportionate position of the wiper from one end of the pot (0) to the other end of the pot (1). The dual versions of the XDCPs use the same serial bus with, of course, different addresses for the individual potentiometers.

For high frequency amplifiers, the high end-to-end resistance of $10k\Omega$ (R_{TOTAL}) of the X9418 creates time constants limiting the bandwidth of the circuit. The effective end-to-end resistance of the potentiometers can be reduced using two techniques shown in the high frequency amplifier circuit of Figure 5. If the wiper of the potentiometer is connected to a high impedance, shunting R_{TOTAL} directly with an external resistor reduces the effective end-to-end resistance. Resistor R_3 changes the effective end-to-end resistance of potentiometer R_2 from $10k\Omega$ to $.909k\Omega$. If the wiper of the potentiometer is *not* connected to a high impedance, the effective end-to-end resistance can be reduced by adding external, equal valued resistors (R_4 and R_5) from the wiper to the high terminal and from the wiper to the low terminal. This technique, however, creates a potentiometer whose taper is pseudo-linear and whose end-to-end resistance varies with wiper position by about 20%. For most applications, these conditions are acceptable. The gain of the amplifier circuit in Figure 5 is programmable from 1 to 2 and the cutoff frequency is programmable from 130kHz to over 1MHz. The principle of computerizing an amplifier is shown in Figure 6 where the amplifier is a functional block and the gain and cutoff frequency are controlled through a serial bus connected to a digitally controlled potentiometer.

The design of high frequency circuits requires low value and sometimes odd value resistances. The two techniques shown in this circuit allow the designer to customize the values of a potentiometer's end-to-end resistance to fit the design requirements.

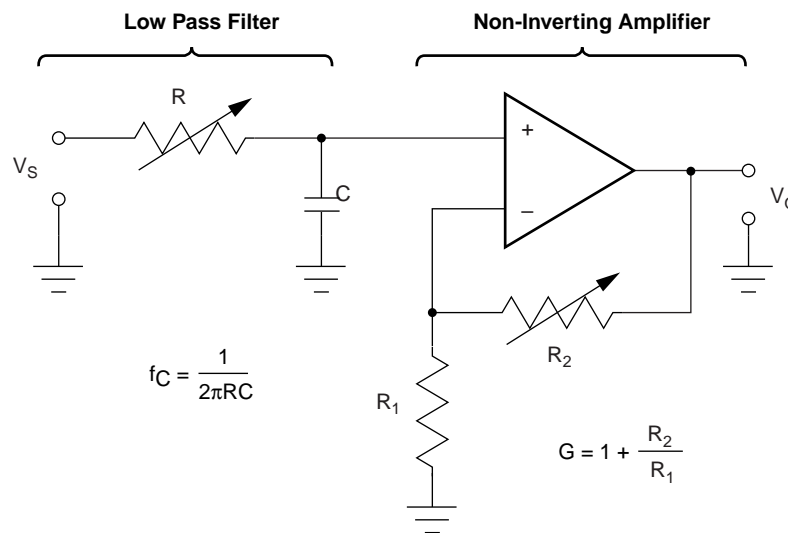

FIGURE 3. MODEL OF AMPLIFIER CIRCUIT

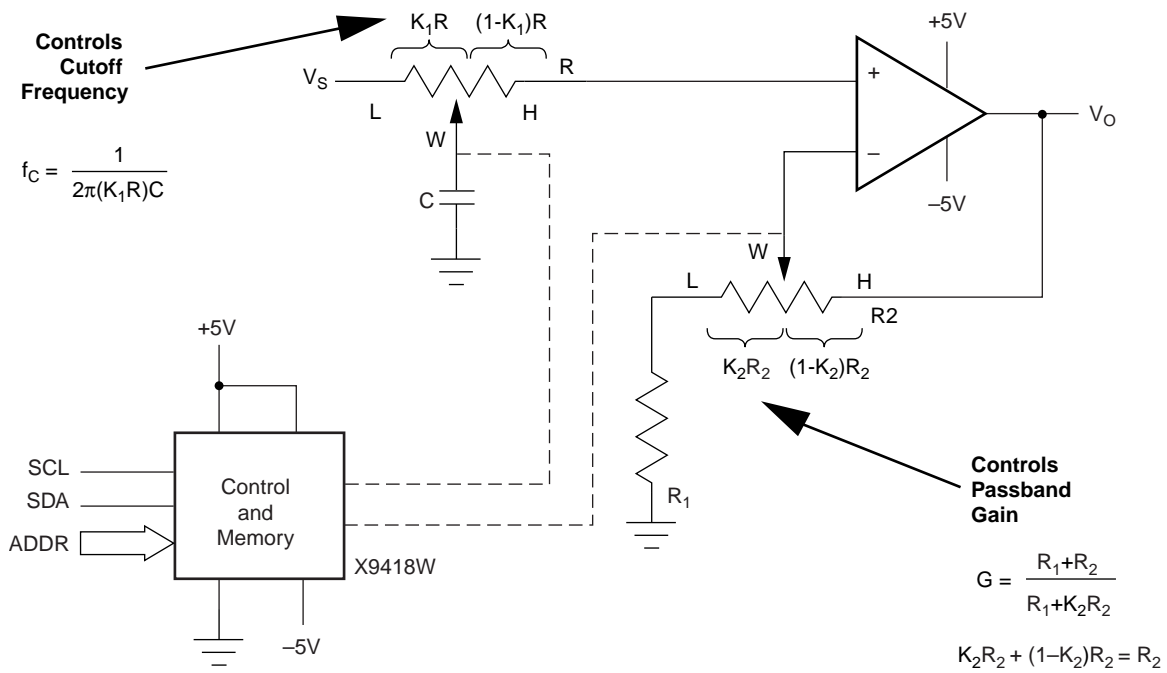

FIGURE 4. GAIN AND FREQUENCY CONTROL

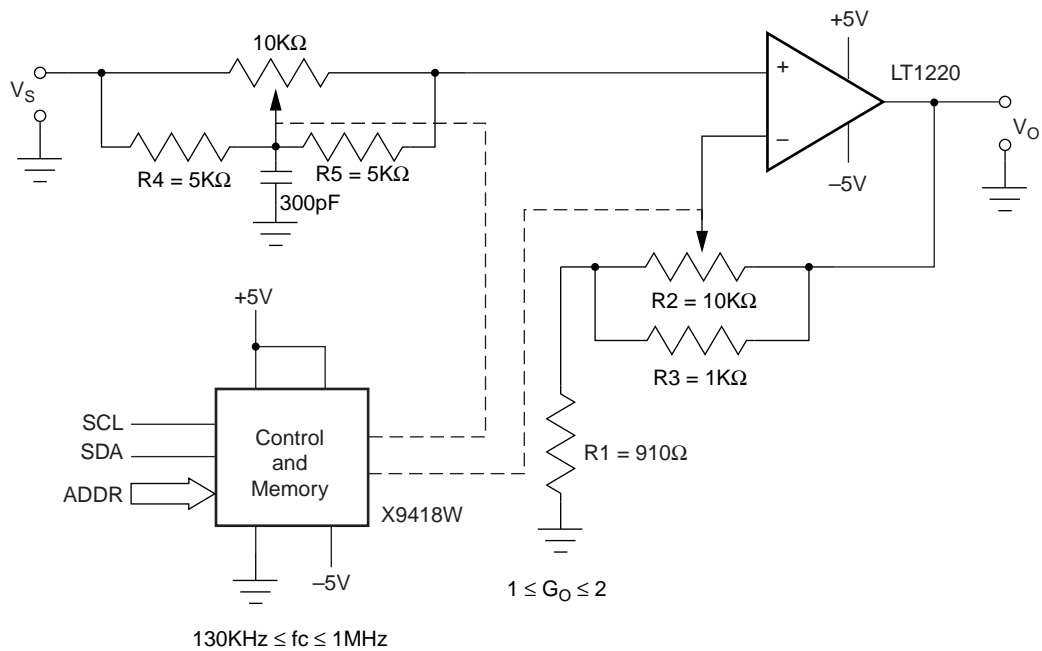

FIGURE 5. HIGH FREQUENCY AMPLIFIER

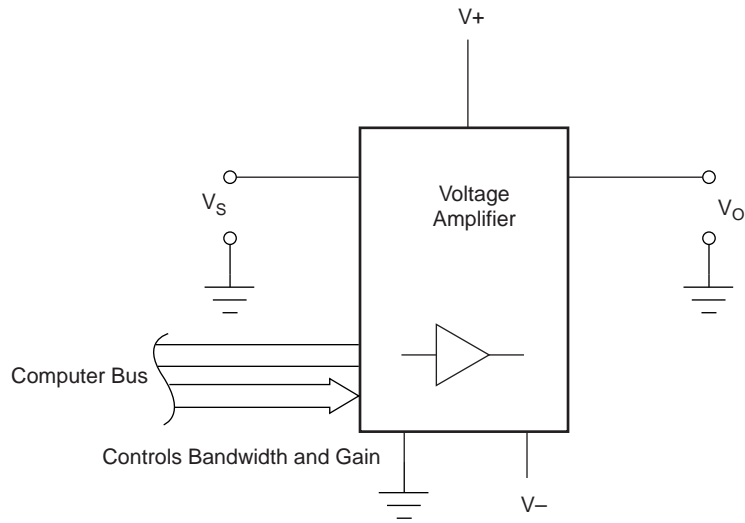

FIGURE 6. PUTTING AN AMPLIFIER ON THE BUS

Programmable System-Level Voltage Regulator

Power consumption and failing batteries are key issues in battery operated applications. Features in the new generation of series voltage regulators address these concerns. For example, National Semiconductor's LP2951 is a micropower voltage regulator which provides a logic-level output signal detecting a low regulated output voltage and has a logic-level input to shutdown the regulator to conserve power. These signals are digital and hence compatible with processor based systems. With these type regulators, system designers can now use the basic device to provide voltage regulation and use the digital signals to address the power and low voltage concerns. But what about the programming or control of the regulator's output voltage? Surely a mechanical potentiometer or resistor selection is not the solution. We can complete the so-called computerization or digitizing of the voltage regulator by adding a digitally controlled potentiometer to program the regulator's output voltage.

The circuit in Figure 7 is wide-range, computer controlled voltage regulator whose nominal output voltage varies from 1.235V to 14.8V. The regulator is programmed using a Intersil digitally controlled potentiometer (XDCCP) which, with its 100 taps or steps, can program the regulator output voltage with a resolution of .136V per step. The output voltage is given as

$$V_O = 1.235V (1 + kR/910\Omega)$$

where k is a number that varies from 0 to 1 and reflects the proportionate position of the wiper from one end of the pot (0) to the other end of the pot (1). R is the end to end resistance of the potentiometer and is also called R_{TOTAL} .

The XDCCP is programmed using a 3-wire bus and the potentiometer is configured as a two-terminal variable resistor. The regulator output signal */ERROR* warns of a low output voltage and may be used as a power-on reset. The logic compatible *SHUTDOWN* input signal enables the regulator to be switched on and off to conserve power. These signals along with the ones required to program the XDCCP are typically connected to the I/O port of the processor or controller.

The potentiometer adds variability to the regulator circuit and its digital controls attached to a computer controlled bus provides programmability. An automated closed-loop calibration procedure to program the regulator saves manufacturing test time and provides enhanced performance and security. The circuit can be used as a bias supply, voltage reference, or as a programmable, high output current, voltage source in test and measurement applications.

The stability of the regulator makes it a potential candidate for applications as a voltage reference. The low-power circuit in Figure 8 is a programmable voltage reference whose output voltage varies from 4.73V to 5.10V in 3.7mV steps. The output voltage is given as

$$V_O = 1.235V [1 + (kR + 100k\Omega) / 34k\Omega]$$

The electronic potentiometer adds variability to the regulator circuit and its digital controls, through its computer controlled bus, provides programmability. An automated closed-loop calibration procedure to program the regulator saves test time and provides enhanced performance and security.

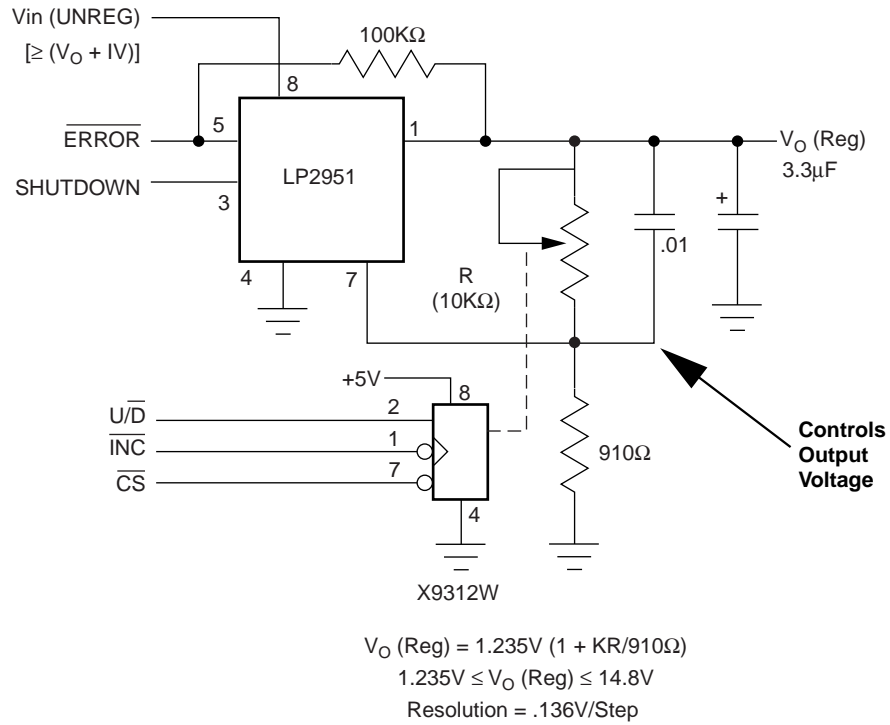

FIGURE 7. PROGRAMMABLE VOLTAGE REGULATOR

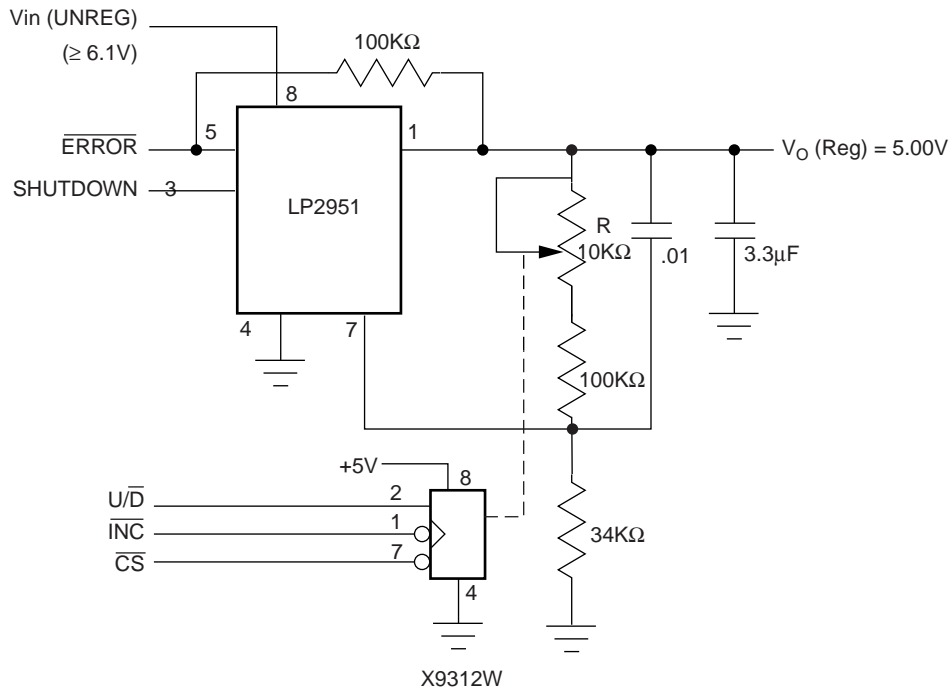
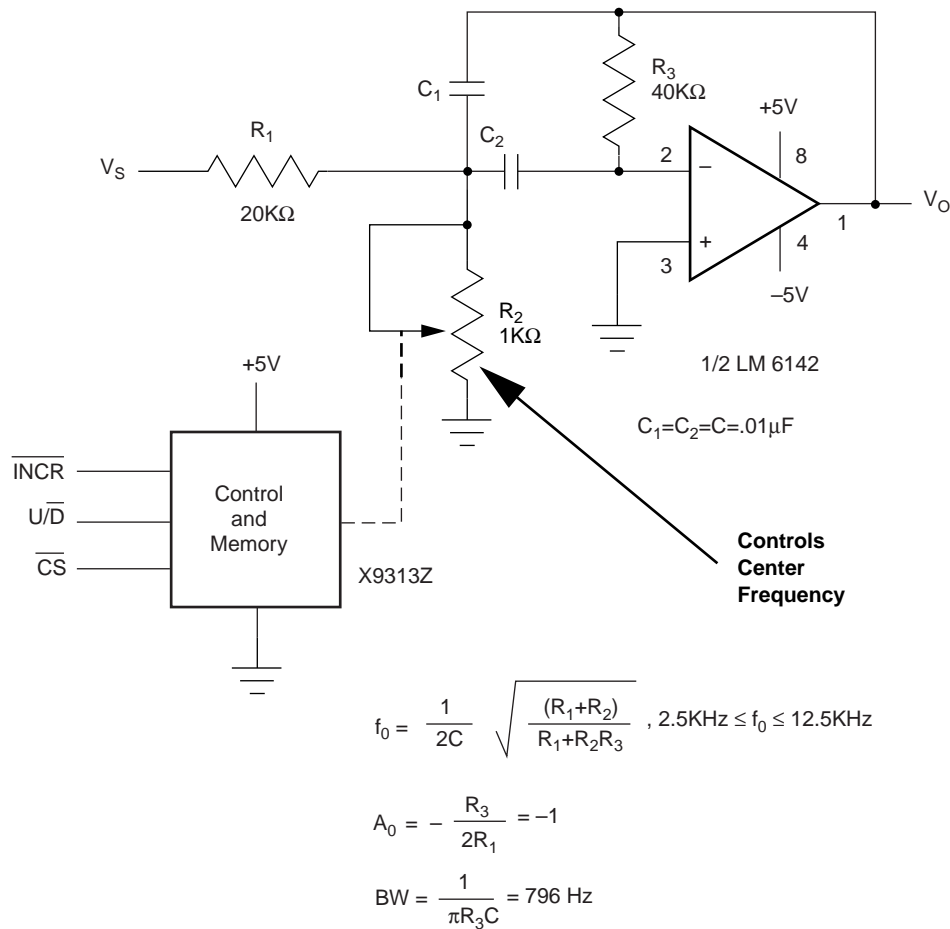

FIGURE 8. PROGRAMMABLE VOLTAGE REGULATOR

FIGURE 9. TUNABLE BAND PASS (IGMF) FILTER

Tunable Bandpass (IGMF) Filter

The circuit in Figure 9 is a tunable bandpass filter that falls in the Infinite Gain Multiple Feedback (IGMF) class. IGMF type filters

$$\frac{V_o}{V_s} = \frac{-s/R_1 C}{s^2 + (2/R_3 C)s + (R_1 + R_2)/R_1 R_2 R_3 C^2} = \frac{A_0 s(\omega_0/Q)}{s^2 + s(\omega_0/Q) + \omega_0^2}$$

where A_0 , ω_0 , and Q represent the passband gain, characteristic frequency, and figure of merit respectively.

From the gain expression,

$$A_0 = -\frac{R_3}{2R_1}$$

$$f_0 = \frac{1}{2\pi C} \sqrt{\frac{(R_1 + R_2)}{R_1 R_2 R_3}}$$

and

$$Q = (1/2) \sqrt{\frac{(R_1 + R_2)R_3}{R_1 R_2}}$$

are characterized by a fixed five-component configuration. For the circuit in Figure 9, the gain expression is

A problem common to most second order, active filters is the dependence of each of the filter's parameters on the values of all or most circuit components. Ideally, of course we would like to have one component control one parameter only. The equations above show that f_0 can be varied by changing R_2 without changing the gain A_0 .

The filter's bandwidth BW

$$BW = \frac{f_0}{Q} = \frac{1}{\pi R_3 C}$$

is also independent of R_2 . Hence varying R_2 will change the center frequency f_0 but not the gain nor the bandwidth of the filter. If R_2 is a Intersil digitally controlled potentiometer (XDCP) connected as a variable resistor, the bandpass filter is digitally tunable and programmable.

For the circuit values shown, the passband gain is minus one, the bandwidth is 796Hz, and the center frequency can be varied from 2.5kHz to 12.5kHz. The circuit can be modified for self-tuning operation.

Digitally-Controlled Potentiometer Programs The 555

The use of the digitally-controlled potentiometer in the circuit of Figure 10 represents a new twist to controlling the heavily used 555 timer IC. The replacement of discrete resistors R_A and R_B in the traditional oscillator application of the 555 circuit with a programmable solid-state potentiometer introduces a degree of freedom that allows the computer control of both the frequency of oscillation and the duty cycle. The potentiometer adds variability to the analog circuit and its digital controls, through its computer-controlled serial bus, provides programmability.

For discrete values of R_A and R_B , the frequency and duty cycle are given as

$$f_o = \frac{1.44}{(R_A + 2R_B)C} \quad \text{and} \quad DC = \frac{R_A + R_B}{R_A + 2R_B}$$

If R_A and R_B are replaced by kR (wiper resistance to one end) and $(1-k)R$ (wiper resistance to the other end) of the potentiometer, the frequency and duty cycle are given as

$$f_o = \frac{1.44}{(2-k)RC} \quad \text{and} \quad DC = \frac{1}{2-k}$$

k is a number that varies from 0 to 1 and reflects the proportionate position of the wiper from one end (0) of the potentiometer to the other end (1). As the wiper is programmed from one end of the potentiometer to the other, the frequency of oscillation will vary from

$$1.44/2RC < f_o < 1.44/RC$$

and the duty cycle will vary from

$$.5 < DC < 1$$

For the circuit values shown, the frequency will vary 725Hz to 1450Hz. The circuit uses Intersil's X9315W which is a 10kΩ potentiometer with 32 taps and a three-wire interface. The number of taps represents the number of programmable wiper positions or frequency and duty cycle values and R (or R_{TOTAL}) is equivalent to $R_A + R_B$. For the Intersil digitally-controlled (XDCP) potentiometers, the number of taps vary from 32 to 256, R_{TOTAL} varies from 1kΩ to 1MΩ, and potentiometers are also available with SPI and I²C interfaces. A wiper setting can be stored in the XDCP's nonvolatile memory permitting the circuit to return to a predetermined frequency and duty cycle value on power-up. The circuit can be used in control, test and measurement, and signal processing applications.

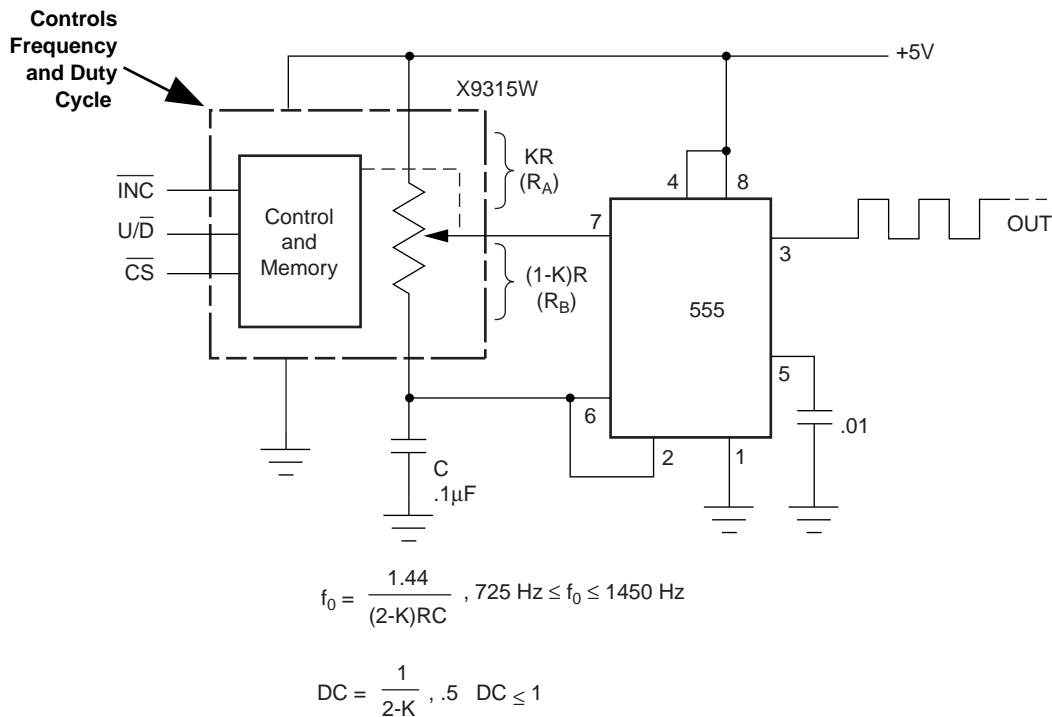

FIGURE 10. 555 RECTANGULAR OSCILLATOR

Phase Shift Sinusoidal Oscillator

The sinusoidal oscillator in Figure 11 is implemented with two all pass filters, A_2 and A_3 , and inverting amplifier A_1 . The magnitude of the gain for each of the circuits A_1 , A_2 and A_3 ($R_3 = R_2$) is ideally one. Hence the magnitude of the loop gain is ideally one. The phase shift of the loop gain is dependent on the phase shift through the all pass filters and it is a function of R , R_1 , and C . The frequency where the phase shift of the loop gain is 360° (or 0°) satisfies the condition for oscillation and hence is the frequency of oscillation. An advantage of this configuration is that the frequency of oscillation can be directly controlled by resistances R or R_1 and no gang tuning of elements is necessary like in many popular oscillator circuits.

The ideal loop gain for this configuration is given by

$$AF = G_{A1}G_{A2}G_{A3} = \left(\frac{R_3}{R_2} \right) \left(\frac{1 - sR_1C}{1 + sR_1C} \right) \left(\frac{1 - sRC}{1 + sRC} \right)$$

whose magnitude is

$$|AF| = \frac{R_3}{R_2}$$

and whose phase shift is

$$\phi = -2 \tan^{-1} \omega RC$$

The frequency of oscillation can be found by solving for the value that results in 360° phase shift or

$$\omega_o = 2\pi f_o = \frac{1}{C} \left[\frac{1}{RR_1} \right]^{1/2}$$

The closed loop gain of A_1 ($R_3 > R_2$) is set to greater than one to compensate for the finite values of open loop gain of the amplifiers and to ensure startup. R or R_1 or both resistors can be used to vary the frequency of oscillation. For the values shown, the programmable frequency range is from 1.5kHz to 9kHz. Zener or reference diodes D_1 and D_2 control the amplitude of the signal.

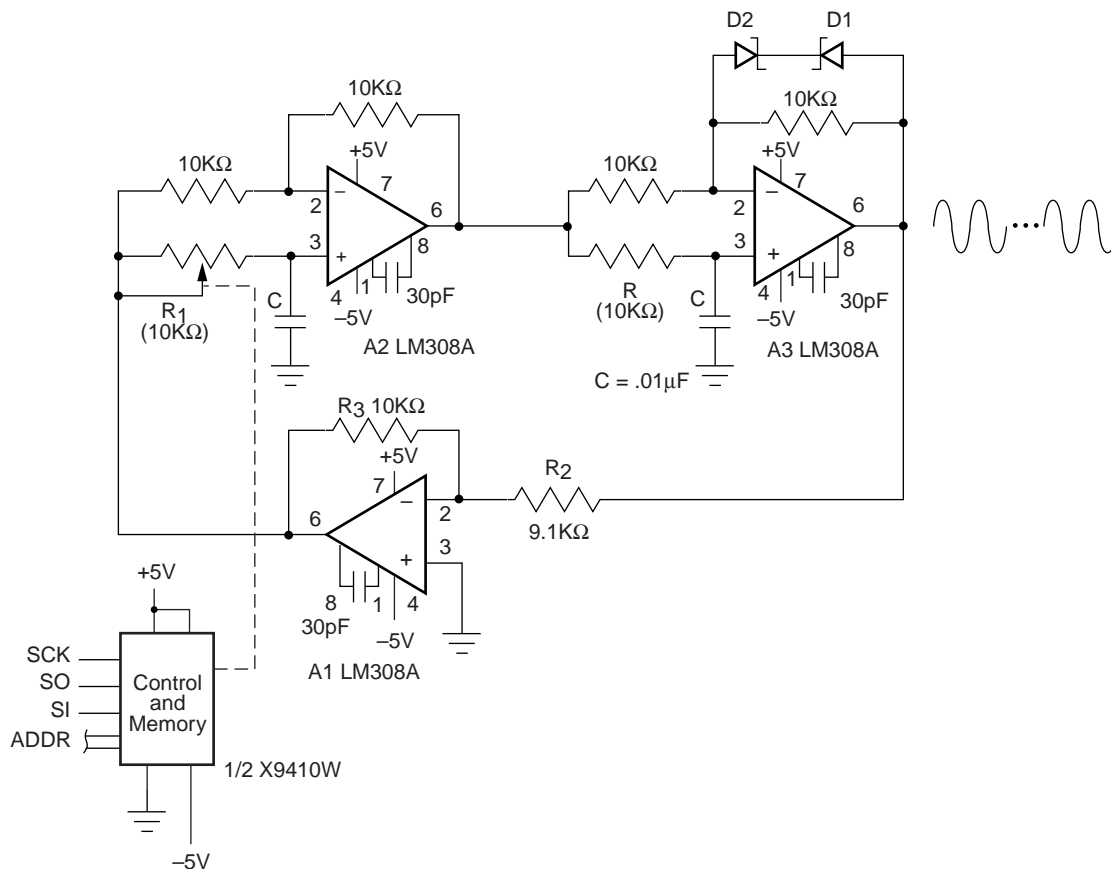

FIGURE 11. PHASE SHIFT SINUSOIDAL OSCILLATOR

I to V Convertor

The circuit in Figure 12 is an input current (I) to output voltage (V) convertor. The feedback portion of the circuit is a tee network of resistive elements consisting of a digitally controlled potentiometer and a fixed resistor $R_1 (=R)$. The input-output relationship for the I to V convertor is

$$\frac{V_o}{I_s} = -R \frac{(1+k-k^2)}{k}$$

where k is a number that varies from 0 to 1 and reflects the proportionate position of the wiper from one end (0) of the potentiometer to the other end (1). The programming of the

location of the wiper changes the scale factor between the input current and output voltage without changing the values of any of the resistances and avoids the use of high value resistors in measuring low values of current. As k goes from 1 to 0, the scale factor goes from $-R$ (1) to a theoretical $-R(\infty)$. The high impedance output of many transducers, like photodiodes and photovoltaic cells, is modeled as a current source.

The programming of the 100 tap potentiometer provides for a two-decade change in effective resistance thus allowing the circuit to measure at least four decades of current. For the values shown, the circuit can measure current from $1\mu\text{A}$ to 1mA .

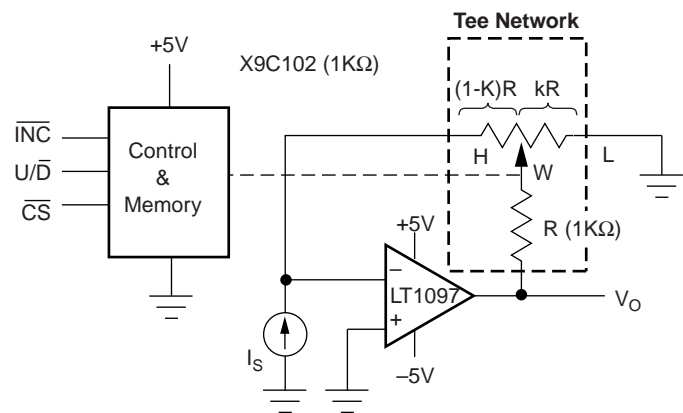

$$\frac{V_o}{I_s} = -R \frac{1+k-k^2}{k} \quad (1-k)R + kR = R = 1K$$

$$1\mu\text{A} < I_s < 1\text{mA}$$

FIGURE 12. I TO V CONVERTOR

Notice

1. Descriptions of circuits, software and other related information in this document are provided only to illustrate the operation of semiconductor products and application examples. You are fully responsible for the incorporation or any other use of the circuits, software, and information in the design of your product or system. Renesas Electronics disclaims any and all liability for any losses and damages incurred by you or third parties arising from the use of these circuits, software, or information.
2. Renesas Electronics hereby expressly disclaims any warranties against and liability for infringement or any other claims involving patents, copyrights, or other intellectual property rights of third parties, by or arising from the use of Renesas Electronics products or technical information described in this document, including but not limited to, the product data, drawings, charts, programs, algorithms, and application examples.
3. No license, express, implied or otherwise, is granted hereby under any patents, copyrights or other intellectual property rights of Renesas Electronics or others.
4. You shall not alter, modify, copy, or reverse engineer any Renesas Electronics product, whether in whole or in part. Renesas Electronics disclaims any and all liability for any losses or damages incurred by you or third parties arising from such alteration, modification, copying or reverse engineering.
5. Renesas Electronics products are classified according to the following two quality grades: "Standard" and "High Quality". The intended applications for each Renesas Electronics product depends on the product's quality grade, as indicated below.
"Standard": Computers; office equipment; communications equipment; test and measurement equipment; audio and visual equipment; home electronic appliances; machine tools; personal electronic equipment; industrial robots; etc.
"High Quality": Transportation equipment (automobiles, trains, ships, etc.); traffic control (traffic lights); large-scale communication equipment; key financial terminal systems; safety control equipment; etc.
Unless expressly designated as a high reliability product or a product for harsh environments in a Renesas Electronics data sheet or other Renesas Electronics document, Renesas Electronics products are not intended or authorized for use in products or systems that may pose a direct threat to human life or bodily injury (artificial life support devices or systems; surgical implantations; etc.), or may cause serious property damage (space system; undersea repeaters; nuclear power control systems; aircraft control systems; key plant systems; military equipment; etc.). Renesas Electronics disclaims any and all liability for any damages or losses incurred by you or any third parties arising from the use of any Renesas Electronics product that is inconsistent with any Renesas Electronics data sheet, user's manual or other Renesas Electronics document.
6. When using Renesas Electronics products, refer to the latest product information (data sheets, user's manuals, application notes, "General Notes for Handling and Using Semiconductor Devices" in the reliability handbook, etc.), and ensure that usage conditions are within the ranges specified by Renesas Electronics with respect to maximum ratings, operating power supply voltage range, heat dissipation characteristics, installation, etc. Renesas Electronics disclaims any and all liability for any malfunctions, failure or accident arising out of the use of Renesas Electronics products outside of such specified ranges.
7. Although Renesas Electronics endeavors to improve the quality and reliability of Renesas Electronics products, semiconductor products have specific characteristics, such as the occurrence of failure at a certain rate and malfunctions under certain use conditions. Unless designated as a high reliability product or a product for harsh environments in a Renesas Electronics data sheet or other Renesas Electronics document, Renesas Electronics products are not subject to radiation resistance design. You are responsible for implementing safety measures to guard against the possibility of bodily injury, injury or damage caused by fire, and/or danger to the public in the event of a failure or malfunction of Renesas Electronics products, such as safety design for hardware and software, including but not limited to redundancy, fire control and malfunction prevention, appropriate treatment for aging degradation or any other appropriate measures. Because the evaluation of microcomputer software alone is very difficult and impractical, you are responsible for evaluating the safety of the final products or systems manufactured by you.
8. Please contact a Renesas Electronics sales office for details as to environmental matters such as the environmental compatibility of each Renesas Electronics product. You are responsible for carefully and sufficiently investigating applicable laws and regulations that regulate the inclusion or use of controlled substances, including without limitation, the EU RoHS Directive, and using Renesas Electronics products in compliance with all these applicable laws and regulations. Renesas Electronics disclaims any and all liability for damages or losses occurring as a result of your noncompliance with applicable laws and regulations.
9. Renesas Electronics products and technologies shall not be used for or incorporated into any products or systems whose manufacture, use, or sale is prohibited under any applicable domestic or foreign laws or regulations. You shall comply with any applicable export control laws and regulations promulgated and administered by the governments of any countries asserting jurisdiction over the parties or transactions.
10. It is the responsibility of the buyer or distributor of Renesas Electronics products, or any other party who distributes, disposes of, or otherwise sells or transfers the product to a third party, to notify such third party in advance of the contents and conditions set forth in this document.
11. This document shall not be reprinted, reproduced or duplicated in any form, in whole or in part, without prior written consent of Renesas Electronics.
12. Please contact a Renesas Electronics sales office if you have any questions regarding the information contained in this document or Renesas Electronics products.
(Note 1) "Renesas Electronics" as used in this document means Renesas Electronics Corporation and also includes its directly or indirectly controlled subsidiaries.
(Note 2) "Renesas Electronics product(s)" means any product developed or manufactured by or for Renesas Electronics.

(Rev.4.0-1 November 2017)



SALES OFFICES

Renesas Electronics Corporation

<http://www.renesas.com>

Refer to "<http://www.renesas.com/>" for the latest and detailed information.

Renesas Electronics America Inc.
1001 Murphy Ranch Road, Milpitas, CA 95035, U.S.A.
Tel: +1-408-432-8888, Fax: +1-408-434-5351

Renesas Electronics Canada Limited
9251 Yonge Street, Suite 8309 Richmond Hill, Ontario Canada L4C 9T3
Tel: +1-905-237-2004

Renesas Electronics Europe Limited
Dukes Meadow, Millboard Road, Bourne End, Buckinghamshire, SL8 5FH, U.K
Tel: +44-1628-651-700, Fax: +44-1628-651-804

Renesas Electronics Europe GmbH
Arcadiastrasse 10, 40472 Düsseldorf, Germany
Tel: +49-211-6503-0, Fax: +49-211-6503-1327

Renesas Electronics (China) Co., Ltd.
Room 1709 Quantum Plaza, No.27 ZhichunLu, Haidian District, Beijing, 100191 P. R. China
Tel: +86-10-8235-1155, Fax: +86-10-8235-7679

Renesas Electronics (Shanghai) Co., Ltd.
Unit 301, Tower A, Central Towers, 555 Langao Road, Putuo District, Shanghai, 200333 P. R. China
Tel: +86-21-2226-0888, Fax: +86-21-2226-0999

Renesas Electronics Hong Kong Limited
Unit 1601-1611, 16/F., Tower 2, Grand Century Place, 193 Prince Edward Road West, Mongkok, Kowloon, Hong Kong
Tel: +852-2265-6688, Fax: +852-2886-9022

Renesas Electronics Taiwan Co., Ltd.
13F, No. 363, Fu Shing North Road, Taipei 10543, Taiwan
Tel: +886-2-8175-9600, Fax: +886-2-8175-9670

Renesas Electronics Singapore Pte. Ltd.
80 Bendemeer Road, Unit #06-02 Hyflux Innovation Centre, Singapore 339949
Tel: +65-6213-0200, Fax: +65-6213-0300

Renesas Electronics Malaysia Sdn.Bhd.
Unit 1207, Block B, Menara Amcorp, Amcorp Trade Centre, No. 18, Jln Persiaran Barat, 46050 Petaling Jaya, Selangor Darul Ehsan, Malaysia
Tel: +60-3-7955-9390, Fax: +60-3-7955-9510

Renesas Electronics India Pvt. Ltd.
No.777C, 100 Feet Road, HAL 2nd Stage, Indiranagar, Bangalore 560 038, India
Tel: +91-80-67208700, Fax: +91-80-67208777

Renesas Electronics Korea Co., Ltd.
17F, KAMCO Yangjae Tower, 262, Gangnam-daero, Gangnam-gu, Seoul, 06265 Korea
Tel: +82-2-558-3737, Fax: +82-2-558-5338