

**Introduction**

Engineers interested in precision signal processing will find the HA-51X7, with its unique features, very interesting. Utilizing an advanced design with special device geometries, the HA-51X7 has moved the Intersil dielectric process into a new arena of both speed and precision. Perhaps one of the most remarkable features of the HA-51X7 is its ultra low noise performance, which makes it the first monolithic amplifier to combine speed, precision, and ultra low noise operation (Figure 1).

**To realize this device, intense attention was given to the "total" design from input to output (Figure 2).**

The input stage consists of a cross-coupled differential pair which provides a very high CMRR (125dB) through the use of CASCODE circuits. Effective use of the bias current cancellation scheme also keeps the bias currents to a mere 10nA. By laser trimming the load resistors, R<sub>1</sub> and R<sub>2</sub>, the offset voltage is kept below 25µV at 25°C. The entire input stage has been optimized for low noise operation and is largely responsible for the amplifier's ultra low noise voltage of 3.0nV/√Hz at 1kHz. Low frequency noise, on the other hand, is particularly important in DC applications and the HA-5147's 2.7Hz lower noise corner will prove quite beneficial for many users.

The loading on R<sub>1</sub> and R<sub>2</sub> is kept to a minimum through the use of emitter followers between the input stage and the second differential pair. C<sub>4</sub> provides a feedforward path around the second stage at high frequencies and feeds into the level shifter and current mirror section. This portion of the design provides a differential to single-ended conversion and relies on C<sub>2</sub> to tailor the rolloff of the second stage. Two vertically-constructed PNP transistors within the level shifter

dramatically increase the frequency response of the amplifier compared to that of other construction techniques.

Emitter followers in the fourth stage reduce the capacitive loading effects of C<sub>1</sub> by providing a separate driver for C<sub>1</sub> and the output stage. The output stage here is a high speed buffer that employs complementary transistors as well as short circuit protection.

The high performance features of the HA-5147 have quite clearly moved this device closer to the "ideal" than any other amplifier in its class. Yet, with some simple external components, this device can be positioned even closer to the "ideal." An offset nulling potentiometer can reduce V<sub>OS</sub> (Figure 3A), while the already hefty output stage (I<sub>OUT</sub> = 20mA Min) can be boosted without reducing the excellent speed and bandwidth characteristics (Figure 3B).

**Low Noise Design**

Since the HA-51X7 is a very low noise operational amplifier, low noise design techniques must be used to make the most of this feature. There are two primary means of keeping noise down, one requires the amplifier inputs to look into low source resistances and the other requires bandwidth limiting by filtering. A short outline of noise prediction will be presented here to support these concepts.

Noise can be divided into several categories, which include thermal noise (white noise) and flicker noise (pink noise or 1/F noise). The feedback components are strongly dominated by thermal noise making thermal noise the most important of these from a system design standpoint (an exception to this are high gain DC amplifiers which require low 1/F noise as measured by the noise corner). Flicker noise is more a function of the amplifier construction quality, and system design variations are less effective in reducing this type of noise.

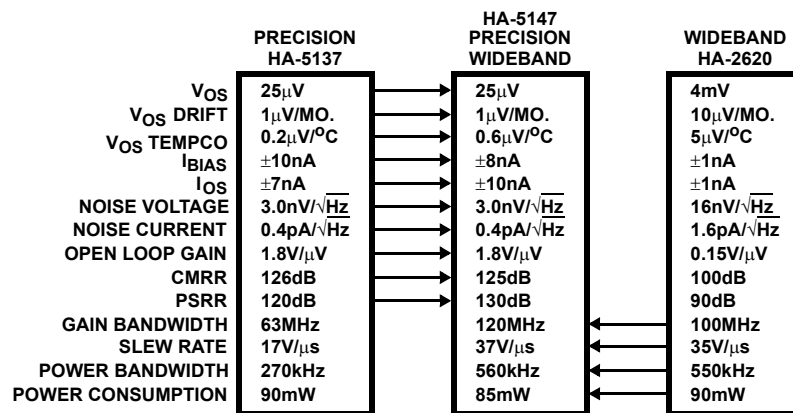

FIGURE 1. THE HA-5147 COMBINES THE QUALITIES OF PRECISION OP AMPS WITH THOSE OF THE WIDEBAND SPEED CATEGORY

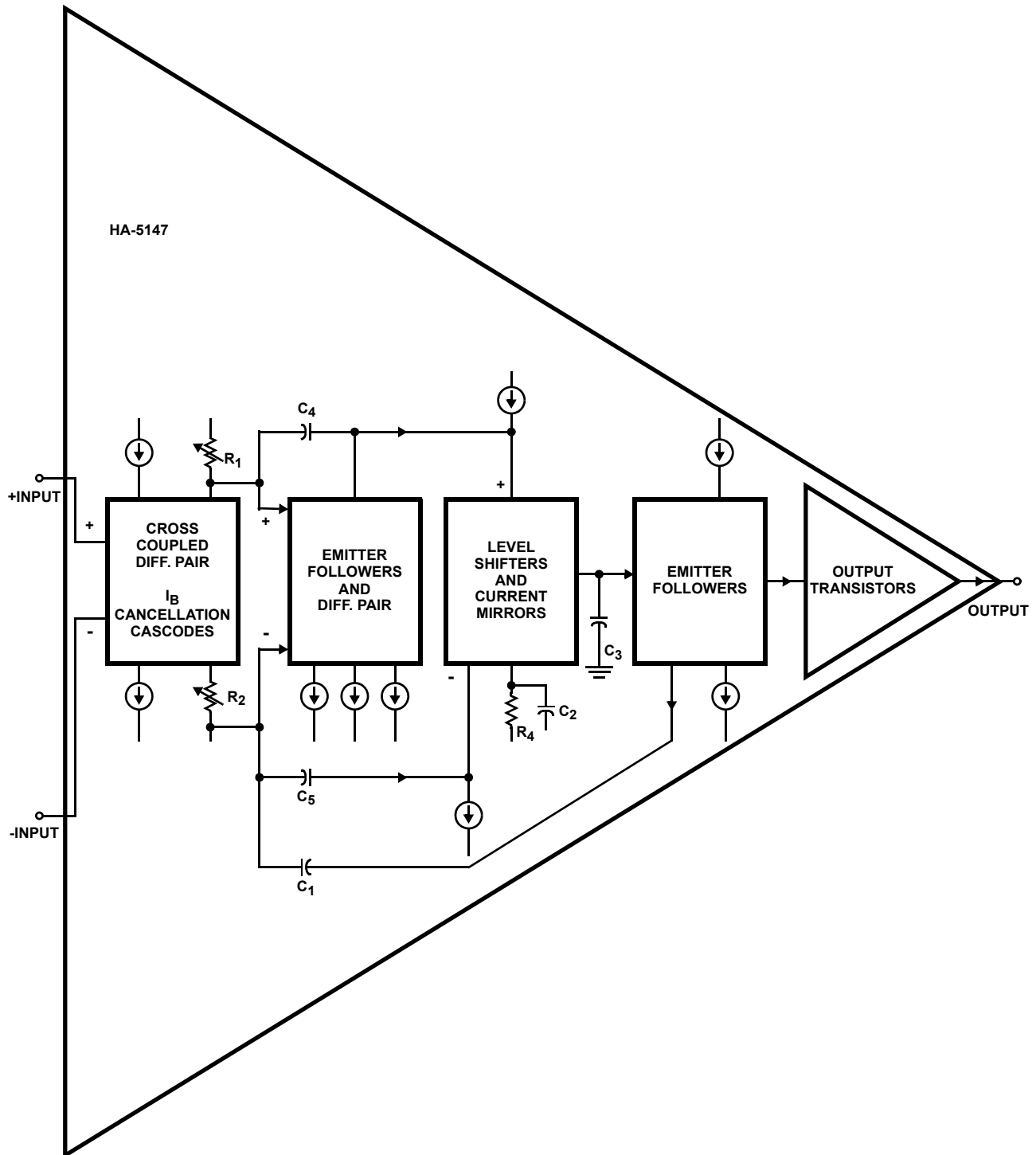

FIGURE 2. INTENSE ATTENTION WAS GIVEN TO THE "TOTAL" DESIGN FROM INPUTS TO OUTPUT

Noise is usually rated in one of two ways. The first is RMS voltage or current (a measure of peak-to-peak noise in a given bandwidth) and the second is by noise density spectrum in  $V/\sqrt{\text{Hz}}$  and  $A/\sqrt{\text{Hz}}$  (a measure of the spectral content of the noise in the frequency domain). The two rating schemes are related, with RMS noise levels generated from the integration of the noise density spectrum over a desired frequency bandwidth.

As an illustration of noise prediction, the noise density for the standard inverting amplifier configuration (Figure 4A) will be determined. The total noise is derived from the combination of several noise sources, only three of which are of any significance. These are the amplifier's noise voltage, the thermal noise of the feedback components, and the noise generated by the noise current of the amplifier within the feedback components.

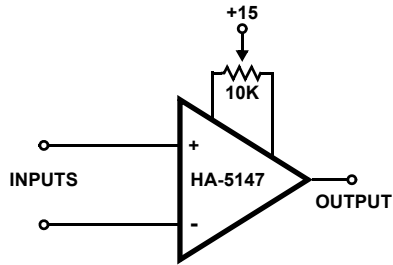
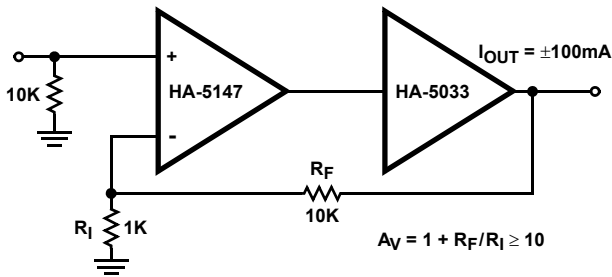
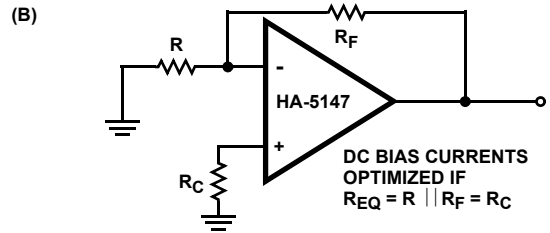
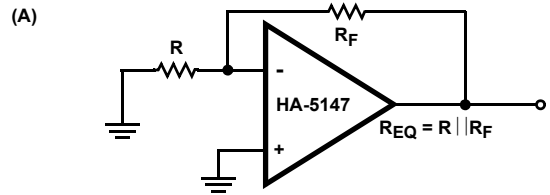

FIGURE 3A. NULLING THE HA-5147'S OFFSET VOLTAGE



NOTE: The HA-5147's output current can be boosted to  $\pm 100\text{mA}$  by using the HA-5033. AC performance is not affected.

FIGURE 3B. CURRENT BOOSTING THE HA-5147



NOTE: A reasonable estimate of noise levels can be generated with these two basic amplifier circuits.

FIGURE 4. NOISE PREDICTION CIRCUITS

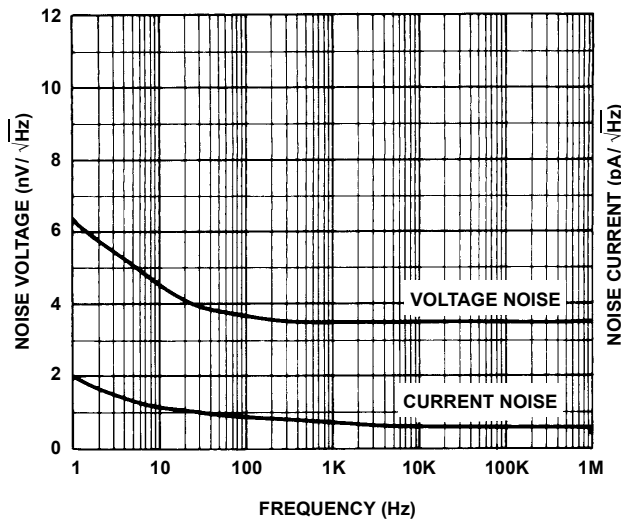

NOTE: The HA-5147's exceptional noise characteristics may be used to improve existing and new high quality audio systems. HA-5127 and HA-5137 have identical noise characteristics.

FIGURE 5. HA-5147 NOISE CHARACTERISTICS

The total noise is defined as the square root of the sum of the squares of the individual noise terms.

$$E_N = G \sqrt{(E_{AMP})^2 + (E_{FEEDBACK NETWORK})^2 + (E_{NOISE CURRENT IN FEEDBACK NETWORK})^2}$$

$E_N$  = TOTAL NOISE

G = GAIN OF STAGE

$E_{AMP}$  = AMPLIFIER NOISE VOLTAGE ..3.0nV/√Hz AT f > 1kHz

$$E_{FEEDBACK NETWORK} = \sqrt{4KTR_{EQ}} \text{ WHERE... } K = 1.381E-23$$

$$T = 300$$

$$R_{EQ} = R || R_F$$

$$E_{NOISE CURRENT IN FEEDBACK NETWORK} = I_{NOISE} R_{EQ}$$

$$I_{NOISE} = 0.4pA/\sqrt{Hz} \text{ AT } f > 1kHz$$

OR MORE SPECIFICALLY.....

$$E_N = G \sqrt{(E_{AMP})^2 + R_{EQ}4KT + (I_{NOISE} R_{EQ})^2}$$

Both the amplifier noise voltage and current noise are constant above 1kHz and rise slightly for lower frequencies (Figure 5). The resistor thermal noise is derived from the parallel combination of the feedback network ( $R_{EQ}$ ) and several constants (4KT). The third noise term again uses the equivalent resistance of the feedback network ( $R_{EQ}$ ) as well as the noise current generated at the input terminals of the amplifier.

It should be evident from the above formula that extremely large values of  $R_{EQ}$  (especially over 10kΩ) will dominate the noise density while low values for  $R_{EQ}$  will yield to the amplifier's own noise characteristics. Note the asymptotic convergence of the noise voltages in Figures 6A - 6C at low values of  $R_{EQ}$ .

A second circuit (Figure 4B) balances the effects of input bias currents by placing a resistor  $R_C$ , equal to  $R_{EQ}$ , between the non-inverting input and ground. While reducing DC errors, this configuration adds two additional terms to the noise formula.

$$E_N = G \sqrt{(E_{AMP})^2 + R_{EQ}4KT + (I_{NOISE} R_{EQ})^2 + R_C 4KT + (I_{NOISE} R_C)^2}$$

The original contributors to output noise remain as before and the additional terms represent the thermal contribution by  $R_C$  and the associated amplifier noise current seen through that resistor. To optimize DC design,  $R || R_F = R_{EQ} = R_C$ , therefore the noise density equation reduces to:

$$E_N = G \sqrt{(E_{AMP})^2 + 2R_{EQ}4KT + 2(I_{NOISE} R_{EQ})^2}$$

Again the relationship between large values of  $R_{EQ}$  and a high noise density spectrum remains.

RMS noise is derived in part as the integral of the noise density spectrum over a given bandwidth. Below is the complete expression:

$$E_{RMS} \text{ (FROM } f_0 \text{ TO } f_1) = \sqrt{\int_{f_0}^{f_1} E_{NOISE DENSITY SPECTRUM}^2 df}$$

The strict integration assuming  $E_N$  is constant, works well for  $f_0$  above  $\approx$  1kHz. Both the amplifier's noise voltage and the noise current increase for frequencies below 1kHz. This makes for difficult integration since complicated expressions for  $I_{NOISE}$  and  $E_{AMP}$  must be generated. To avoid this problem, graphical integration techniques or sampled methods can be used with great success.

The curves in Figures 6A - 6C illustrate the relationship between the RMS noise and  $R_{EQ}$  for both amplifier designs. It should be apparent from the predicted RMS noise curves that increased bandwidth causes an increase in noise voltage. An interesting effect of this relationship is that only absolute bandwidth ( $f_1 - f_0$ ) is important. The general frequencies of interest (if they are above 1kHz) are irrelevant. More simply, 100Hz of bandwidth near 10kHz contains as much noise as 100Hz of bandwidth near 1MHz. This implies that bandwidth should be restricted with appropriate high and low pass filtering, if the lowest noise voltages are to be attained.

From the previous discussion, it is apparent that low noise designs require low resistor values. This is not to say that high gain should be avoided, just that low input and source resistance values are required for low noise operation. Closer examination of the RMS noise formula will also show that limiting bandwidth, with filtering, will also reduce noise levels. Additionally, metal film and wire-wound resistors have lower excess noise (a component of resistor noise in addition to thermal noise) than carbon resistors and are therefore preferred.

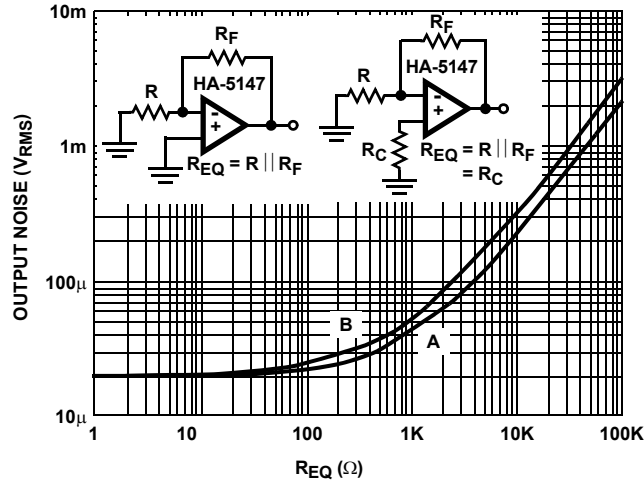

FIGURE 6A. PREDICTED NOISE FOR 10kHz TO 500kHz BANDWIDTH

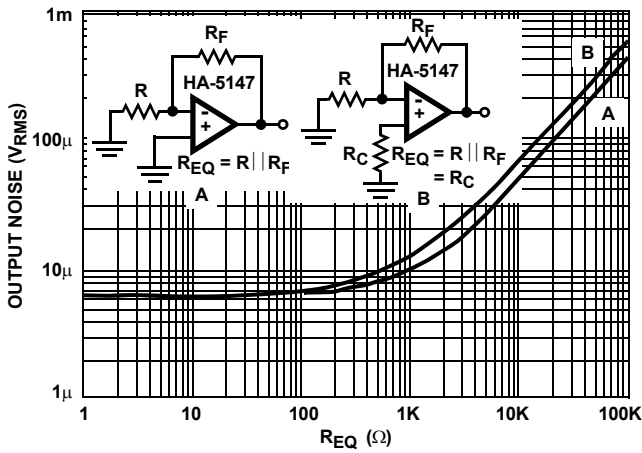

FIGURE 6B. PREDICTED NOISE FOR 20Hz TO 20kHz BANDWIDTH

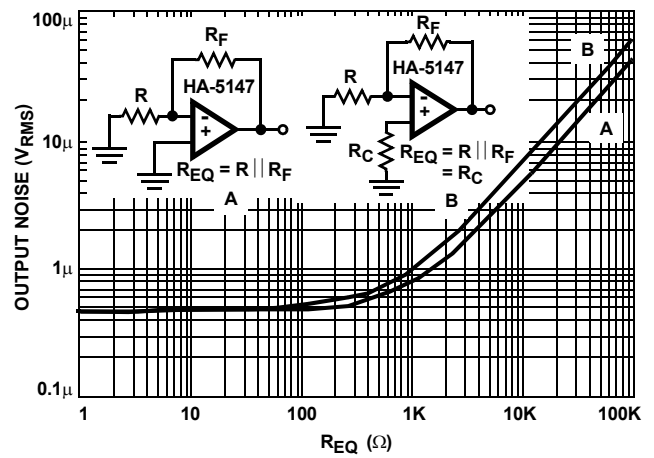

FIGURE 6C. PREDICTED NOISE FOR 10Hz TO 100Hz BANDWIDTH

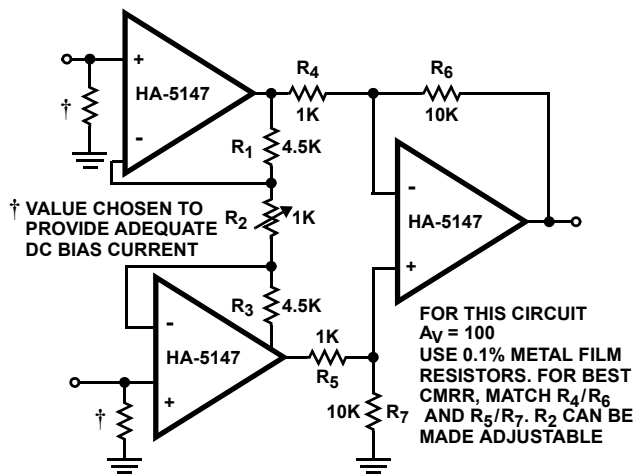

FIGURE 7. INSTRUMENTATION AMPLIFIER

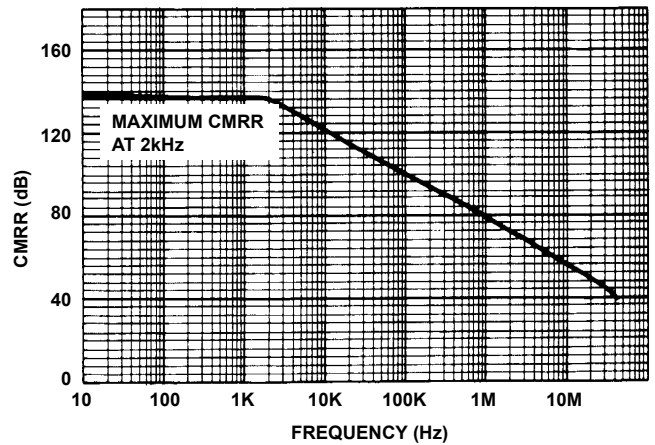
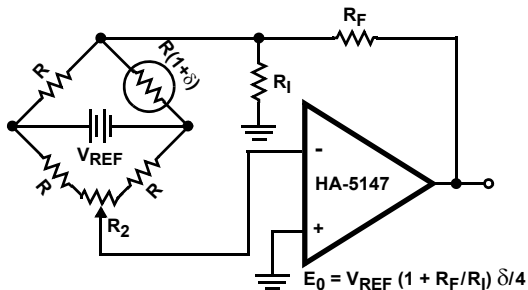

FIGURE 8. HA-5147 CMRR vs FREQUENCY

## Applications

Heavily used throughout the world of signal processing is the instrumentation amplifier and it is this particular circuit that can best utilize all of the features of the HA-5147. By using the HA-5147, the standard 3 amplifier instrumentation circuit (Figure 7) is now able to extend its bandwidth to 10MHz or its power bandwidth to 500kHz. Additionally, the maximum CMRR (> 120dB) is extended to higher frequencies (Figure 8). Other "error producing" input referred parameters of the HA-5147 such as noise,  $V_{OS}$ ,  $I_{BIAS}$ ,  $V_{OS}$  drift and temperature coefficients have been minimized, thus maximizing the capabilities of this application.



NOTE: Very small bridge signals are sensed and amplified accurately when using the precision performance of the HA-5147.

FIGURE 9. LOW LEVEL BRIDGE AMPLIFIER

Another circuit requiring very accurate amplification of its signal is the transducer bridge amplifier (Figure 9). The HA-5147, shown in an inverting bridge amplifier configuration, is recommended when it is necessary to detect very small level bridge signals. Its high open loop gain (>120dB), low noise, and excellent values for  $V_{OS}$ ,  $V_{OS}$  drift, and bias current provide exceptional sensitivity to the smallest transducer variations. Full scale calibration of this circuit is made possible by placing a

small valued potentiometer in series with  $R_1$ . Nulling is accomplished with  $R_2$ .

The high slew rate ( $37V/\mu s$ ) and the excellent output current drive ( $\pm 20mA$  min.) make HA-5147 highly suitable as an input or output buffer for analog multiplexers (Figure 10). The precision input characteristics of the HA-5147 help simplify system "error budgets" while its speed and drive capabilities provide fast charging of the multiplexer's output capacitance. This eliminates any increased multiplexer acquisition time, which can be induced by more limited amplifiers. The HA-5147 accurately transfers information to the next stage while effectively reducing any loading effects on the multiplexer's output.

Staying within the realm of signal processing, another standard and much used circuit configuration can be enhanced by the speed and precision of the HA-5147. A precision threshold detector (Figure 11) requires low noise, low and stable offset voltage, high open loop gain, and high speed. These requirements are met by the HA-5147, while adding excellent CMRR and PSRR to the list. The standard variations of this circuit can easily be implemented using the HA-5147. For example, hysteresis can be generated by adding  $R_1$  to provide a small amount of positive feedback. The circuit becomes a pulse width modulator if  $V_{REF}$  and the input signal are left to vary. Although the output drive capability of this device is excellent, the optional buffering circuit may be used to drive heavier loads while preventing loading effects on the amplifier.

Engineers working with professional audio designs will find the HA-5147 highly desirable for many of their applications. With its exceptional noise characteristics (Figure 5), wide power bandwidth (500kHz), and modest power consumption (85mW), this device can be used as a high quality audio preamplifier or as an intermediate stage gain block. A circuit similar to that in Figure 3B can be incorporated into studio or stage monitors.

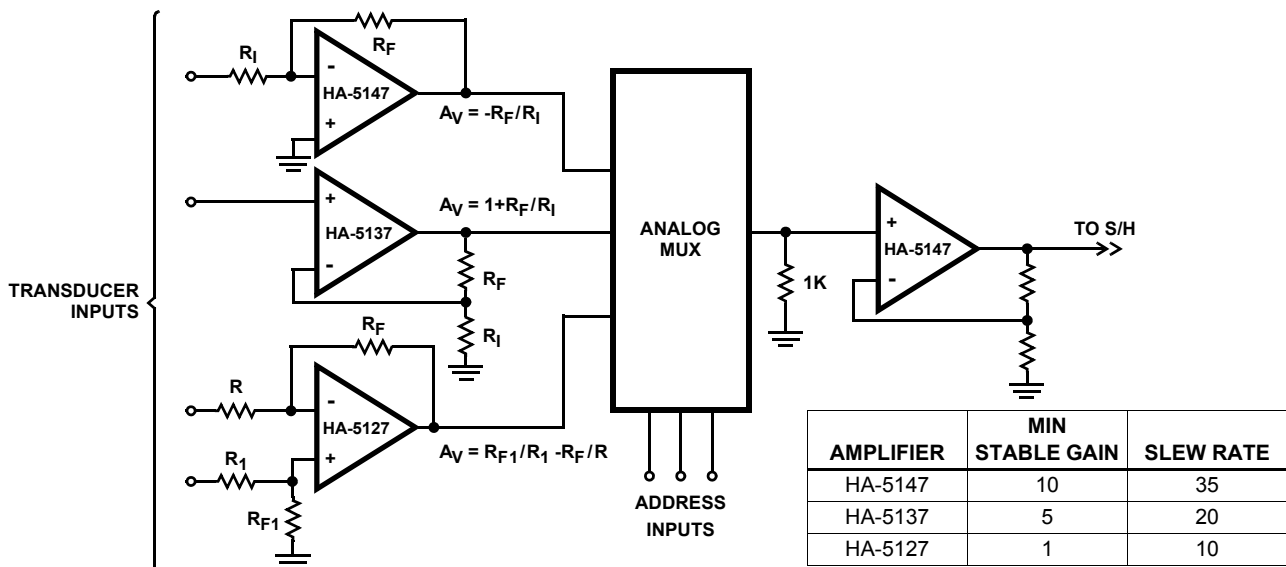

NOTE: Reduced "error budgets" and higher speeds of operation are easily achieved when the combined speed and precision of the HA-51X7 are used in these buffer amplifier applications.

FIGURE 10. HIGH SPEED INPUT/OUTPUT ANALOG MULTIPLEXER BUFFERING

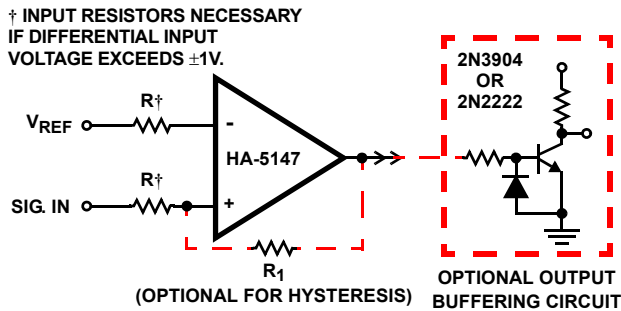

NOTE: This device can be used to increase response times while maintaining precise detection.

FIGURE 11. PRECISION THRESHOLD DETECTOR

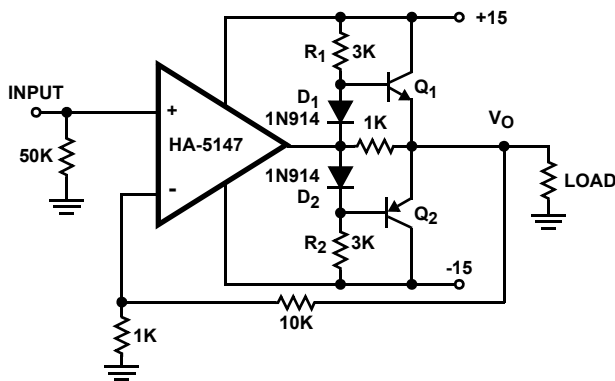

NOTE: The additional drive capability of the power transistors allows the HA-5147 to drive very heavy loads.

FIGURE 12. HIGH POWER AMPLIFIER

The audio preamplifier of Figure 3B has a limited output current range. The audio power amplifier in Figure 12 overcomes this limitation and can provide an even greater boost to the HA-5147. Q<sub>1</sub> and Q<sub>2</sub> are a complementary pair arranged in a push pull manner, with R<sub>1</sub> and R<sub>2</sub> providing the necessary drive current. The maximum output voltage corresponds to the minimum output current since:

$$(15 - V_{BE} - V_O) / R_1$$

is the drive current to the transistors. D<sub>1</sub> and D<sub>2</sub> ensure the proper biasing of the transistors as well as a clean crossover from Q<sub>1</sub> to Q<sub>2</sub>.

An audio circuit which can make maximum use of the speed, bandwidth, and low noise of the HA-5147 is the NAB tape playback preamplifier (Figure 13). This circuit is configured to provide low frequency boost to 50Hz, flat response to 3kHz, and high frequency attenuation above 3kHz. Compensation for variations in tape and tape head performance can be achieved by trimming R<sub>1</sub> and R<sub>2</sub>.

Signal generation applications will also find this high precision device useful. As an astable multivibrator (Figure 14) the power bandwidth of the HA-5147 extends the circuit's frequency range to approximately 500kHz. R<sub>T</sub> can be made adjustable to vary the frequency if desired. Any timing errors

due to V<sub>OS</sub> or I<sub>BIAS</sub> have been minimized by the precision characteristics of the HA-5147. D<sub>1</sub> and D<sub>2</sub>, if used, should be matched to prevent additional timing errors. These clamping diodes may be omitted by tying R<sub>T</sub> and the positive feedback resistor R<sub>F</sub> directly to the output.

† DC BLOCKING CAPACITOR, OPTIONAL, TO BLOCK OUTPUT OFFSET VOLTAGE IF HA-5147 IS NOT NULLED.

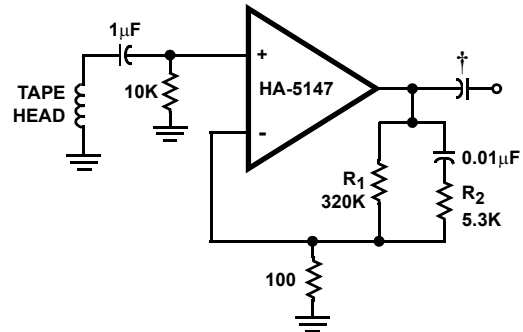

NOTE: This NAB tape playback preamplifier fully utilizes the speed, bandwidth, and noise features of the HA-5147.

FIGURE 13. PROFESSIONAL AUDIO NAB TAPE PLAYBACK PREAMPLIFIER

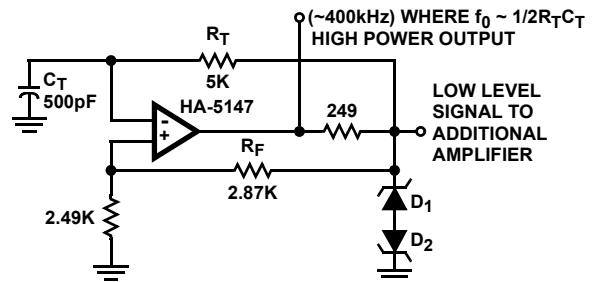

NOTE: Higher frequencies of operation and reduced timing errors make the HA-5147 an attractive building block in signal generation applications.

FIGURE 14. ASTABLE MULTIVIBRATOR

Often a circuit will be called upon to perform several functions. In these situations the variable gain configuration of Figure 15 may be quite useful. This programmable gain stage depends on CMOS analog switches to alter the amount of feedback and thereby the gain of the stage. Placement of the switching elements inside the relatively low current area of the feedback loop, minimizes the effects of bias currents and switch resistance on the calculated gain of the stage. Voltage spikes may occur during the switching process, resulting in temporarily reduced gain because of the make-before-break operation of the switches. This can be minimized by providing a separate voltage divider network for each level of gain.

Many signal processing applications depend on low noise characteristics for their operation. One such application involves logarithmic amplifiers. The input sensitivity range is governed by the system noise in such a circuit. The HA-5147, with its low noise characteristics, can extend the basic



sensitivity of the common logarithmic amplifier (Figure 16). The circuit uses a matched pair of transistors to offset the effects of temperature and quiescent currents. The final expression for  $V_{OUT}$  reduces to:

$$V_{OUT} = -0.026(1 + R_5/R_6) \ln[20V_{IN}/V_{REF}]$$

or using the schematic values:

$$V_{OUT} = -\ln[2V_{IN}]$$

$R_6$  should be temperature dependent if the expression for  $V_{OUT}$  is to hold over an extended temperature range. The overall sensitivity is from a few millivolts to about twice  $V_{REF}$ .

A high signal to noise ratio is important in signal construction and combination. The HA-5147 aids in lowering overall system noise and thereby raises system sensitivity. The signal combination circuit in Figure 17 incorporates input buffering with several other features to form a relatively efficient mixer stage.

The potentiometer used for each channel allows for both variable input levels as well as a constant impedance for the driving source. The buffers serve mainly to prevent reverse crosstalk back through the resistor network. This allows for the combination of varying strength signals without reverse contamination. The gain of the final stage is set at a minimum of 10 and can be adjusted to as much as 20. This allows a great deal of flexibility in combining a vast array of input signals.

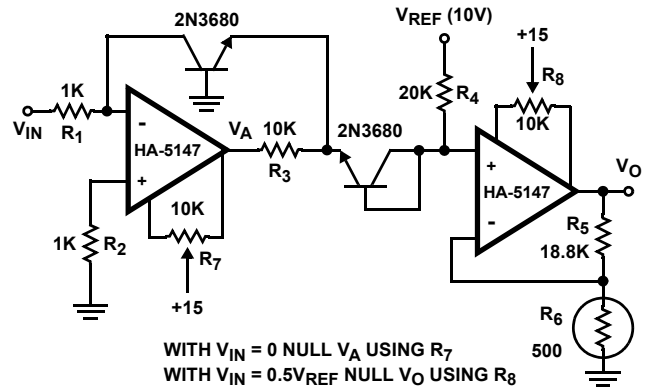

NOTE: The matched pair of transistors makes this a very temperature stable logarithmic amplifier.

FIGURE 16. LOGARITHMIC AMPLIFIER

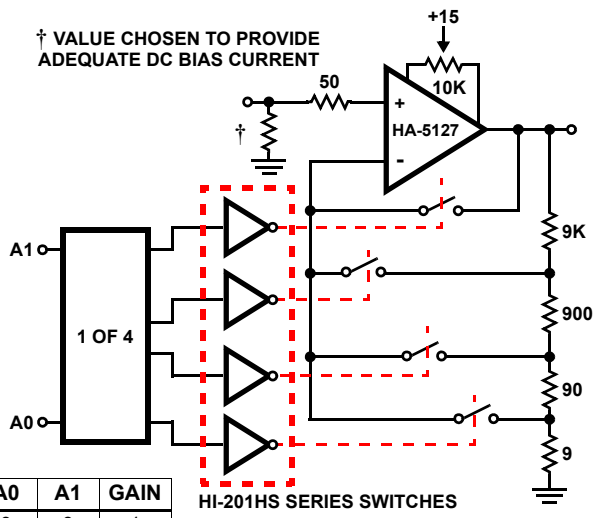

A0	A1	GAIN
0	0	1
0	X	10
X	0	100
X	X	1000

NOTE: Variable gain of 1, 10, 100, 1000 is achieved by selecting the proper amount of feedback with analog switches.

FIGURE 15. PROGRAMMABLE GAIN AMPLIFIER

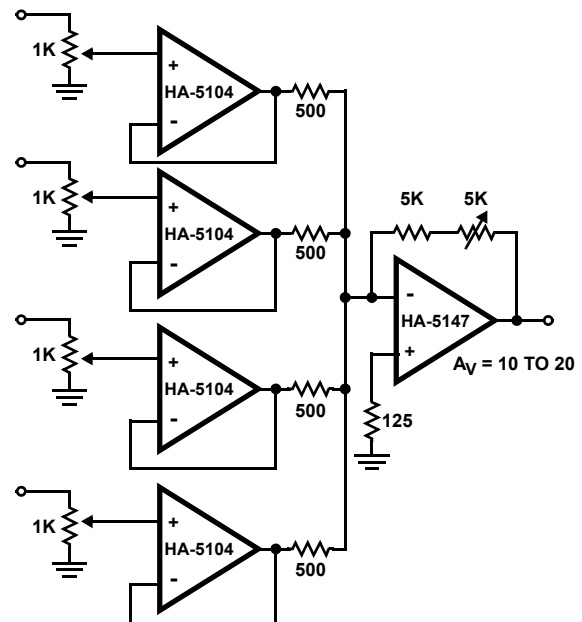

NOTE: Several signals can be combined using this circuit with a minimum of channel crosstalk.

FIGURE 17. INPUT BUFFERED MIXER

## References

- [1] *DC Amplifier Noise Revisited*, Al Ryan and Tim Scranton, Analog Dialog, 1969.
- [2] Fitchen, F.C. and Motchenbacher, C.D. *Low Noise Electronic Design*, New York: John Wiley and Sons, 1973.
- [3] *Instruction Manual*, model 2173C Transistor Noise Analyzer Control Unit. Quan-Tech, Division of KMS Industries. Whippany, New York.



## Notice

1. Descriptions of circuits, software and other related information in this document are provided only to illustrate the operation of semiconductor products and application examples. You are fully responsible for the incorporation or any other use of the circuits, software, and information in the design of your product or system. Renesas Electronics disclaims any and all liability for any losses and damages incurred by you or third parties arising from the use of these circuits, software, or information.
2. Renesas Electronics hereby expressly disclaims any warranties against and liability for infringement or any other claims involving patents, copyrights, or other intellectual property rights of third parties, by or arising from the use of Renesas Electronics products or technical information described in this document, including but not limited to, the product data, drawings, charts, programs, algorithms, and application examples.
3. No license, express, implied or otherwise, is granted hereby under any patents, copyrights or other intellectual property rights of Renesas Electronics or others.
4. You shall not alter, modify, copy, or reverse engineer any Renesas Electronics product, whether in whole or in part. Renesas Electronics disclaims any and all liability for any losses or damages incurred by you or third parties arising from such alteration, modification, copying or reverse engineering.
5. Renesas Electronics products are classified according to the following two quality grades: "Standard" and "High Quality". The intended applications for each Renesas Electronics product depends on the product's quality grade, as indicated below.  
"Standard": Computers; office equipment; communications equipment; test and measurement equipment; audio and visual equipment; home electronic appliances; machine tools; personal electronic equipment; industrial robots; etc.  
"High Quality": Transportation equipment (automobiles, trains, ships, etc.); traffic control (traffic lights); large-scale communication equipment; key financial terminal systems; safety control equipment; etc.  
Unless expressly designated as a high reliability product or a product for harsh environments in a Renesas Electronics data sheet or other Renesas Electronics document, Renesas Electronics products are not intended or authorized for use in products or systems that may pose a direct threat to human life or bodily injury (artificial life support devices or systems; surgical implantations; etc.), or may cause serious property damage (space system; undersea repeaters; nuclear power control systems; aircraft control systems; key plant systems; military equipment; etc.). Renesas Electronics disclaims any and all liability for any damages or losses incurred by you or any third parties arising from the use of any Renesas Electronics product that is inconsistent with any Renesas Electronics data sheet, user's manual or other Renesas Electronics document.
6. When using Renesas Electronics products, refer to the latest product information (data sheets, user's manuals, application notes, "General Notes for Handling and Using Semiconductor Devices" in the reliability handbook, etc.), and ensure that usage conditions are within the ranges specified by Renesas Electronics with respect to maximum ratings, operating power supply voltage range, heat dissipation characteristics, installation, etc. Renesas Electronics disclaims any and all liability for any malfunctions, failure or accident arising out of the use of Renesas Electronics products outside of such specified ranges.
7. Although Renesas Electronics endeavors to improve the quality and reliability of Renesas Electronics products, semiconductor products have specific characteristics, such as the occurrence of failure at a certain rate and malfunctions under certain use conditions. Unless designated as a high reliability product or a product for harsh environments in a Renesas Electronics data sheet or other Renesas Electronics document, Renesas Electronics products are not subject to radiation resistance design. You are responsible for implementing safety measures to guard against the possibility of bodily injury, injury or damage caused by fire, and/or danger to the public in the event of a failure or malfunction of Renesas Electronics products, such as safety design for hardware and software, including but not limited to redundancy, fire control and malfunction prevention, appropriate treatment for aging degradation or any other appropriate measures. Because the evaluation of microcomputer software alone is very difficult and impractical, you are responsible for evaluating the safety of the final products or systems manufactured by you.
8. Please contact a Renesas Electronics sales office for details as to environmental matters such as the environmental compatibility of each Renesas Electronics product. You are responsible for carefully and sufficiently investigating applicable laws and regulations that regulate the inclusion or use of controlled substances, including without limitation, the EU RoHS Directive, and using Renesas Electronics products in compliance with all these applicable laws and regulations. Renesas Electronics disclaims any and all liability for damages or losses occurring as a result of your noncompliance with applicable laws and regulations.
9. Renesas Electronics products and technologies shall not be used for or incorporated into any products or systems whose manufacture, use, or sale is prohibited under any applicable domestic or foreign laws or regulations. You shall comply with any applicable export control laws and regulations promulgated and administered by the governments of any countries asserting jurisdiction over the parties or transactions.
10. It is the responsibility of the buyer or distributor of Renesas Electronics products, or any other party who distributes, disposes of, or otherwise sells or transfers the product to a third party, to notify such third party in advance of the contents and conditions set forth in this document.
11. This document shall not be reprinted, reproduced or duplicated in any form, in whole or in part, without prior written consent of Renesas Electronics.
12. Please contact a Renesas Electronics sales office if you have any questions regarding the information contained in this document or Renesas Electronics products.  
(Note 1) "Renesas Electronics" as used in this document means Renesas Electronics Corporation and also includes its directly or indirectly controlled subsidiaries.  
(Note 2) "Renesas Electronics product(s)" means any product developed or manufactured by or for Renesas Electronics.

(Rev.4.0-1 November 2017)



### SALES OFFICES

Renesas Electronics Corporation

<http://www.renesas.com>

Refer to "<http://www.renesas.com/>" for the latest and detailed information.

**Renesas Electronics America Inc.**  
1001 Murphy Ranch Road, Milpitas, CA 95035, U.S.A.  
Tel: +1-408-432-8888, Fax: +1-408-434-5351

**Renesas Electronics Canada Limited**  
9251 Yonge Street, Suite 8309 Richmond Hill, Ontario Canada L4C 9T3  
Tel: +1-905-237-2004

**Renesas Electronics Europe Limited**  
Dukes Meadow, Millboard Road, Bourne End, Buckinghamshire, SL8 5FH, U.K  
Tel: +44-1628-651-700, Fax: +44-1628-651-804

**Renesas Electronics Europe GmbH**  
Arcadiastrasse 10, 40472 Düsseldorf, Germany  
Tel: +49-211-6503-0, Fax: +49-211-6503-1327

**Renesas Electronics (China) Co., Ltd.**  
Room 1709 Quantum Plaza, No.27 ZhichunLu, Haidian District, Beijing, 100191 P. R. China  
Tel: +86-10-8235-1155, Fax: +86-10-8235-7679

**Renesas Electronics (Shanghai) Co., Ltd.**  
Unit 301, Tower A, Central Towers, 555 Langao Road, Putuo District, Shanghai, 200333 P. R. China  
Tel: +86-21-2226-0888, Fax: +86-21-2226-0999

**Renesas Electronics Hong Kong Limited**  
Unit 1601-1611, 16/F., Tower 2, Grand Century Place, 193 Prince Edward Road West, Mongkok, Kowloon, Hong Kong  
Tel: +852-2265-6688, Fax: +852-2886-9022

**Renesas Electronics Taiwan Co., Ltd.**  
13F, No. 363, Fu Shing North Road, Taipei 10543, Taiwan  
Tel: +886-2-8175-9600, Fax: +886-2-8175-9670

**Renesas Electronics Singapore Pte. Ltd.**  
80 Bendemeer Road, Unit #06-02 Hyflux Innovation Centre, Singapore 339949  
Tel: +65-6213-0200, Fax: +65-6213-0300

**Renesas Electronics Malaysia Sdn.Bhd.**  
Unit 1207, Block B, Menara Amcorp, Amcorp Trade Centre, No. 18, Jln Persiaran Barat, 46050 Petaling Jaya, Selangor Darul Ehsan, Malaysia  
Tel: +60-3-7955-9390, Fax: +60-3-7955-9510

**Renesas Electronics India Pvt. Ltd.**  
No.777C, 100 Feet Road, HAL 2nd Stage, Indiranagar, Bangalore 560 038, India  
Tel: +91-80-67208700, Fax: +91-80-67208777

**Renesas Electronics Korea Co., Ltd.**  
17F, KAMCO Yangjae Tower, 262, Gangnam-daero, Gangnam-gu, Seoul, 06265 Korea  
Tel: +82-2-558-3737, Fax: +82-2-558-5338