

Nonideality of Ground

Ground is supposed to be ideal. It should be a black hole for stray currents where the voltage is always zero. Unfortunately, those stray currents travel through some non-superconducting material, so small voltages arise. You may not notice small changes in ground potential, you may, instead, notice surplus noise or instability or other unwanted attributes in your system. We are going to discuss ground. Every circuit is unique and grounding paths are different for every device on your board and in your system. Therefore, we are starting with an intuitive approach to try and give you a feel for the paths currents choose to travel and how that affects the ideal assumption of ground being zero volts.

First, remember that circuits are only complete when current has a complete path to travel (that is why a switch can be placed anywhere along that path to interrupt flow and function). The power supply creates a potential difference, a push, for the current if a path exists for it to travel. Assuming a single-supply system, it's natural for us to ensure that the positive supply connection is as short and clean as possible. We add bypass capacitors-sometimes multiple values and types of bypass capacitors-to filter the power supply voltage where it enters every critical chip. Then, since there is a ground pin on our IC, we dutifully hook it to a grounded wire or ground plane. For many of us, that's the last we think about ground... unless there's a problem.

One of the common methods for tracking down a problem is to probe important nodes in the circuit with a digital multimeter. If that doesn't illuminate the problem, try probing ground in a variety of places. You might be surprised with what you find. The ground in a system is quite like the ground we find in nature. There are holes from burrowing animals and there are a variety of materials from sand, clay, soil and types of rock. The consistency and structure of the materials affects how things like water, animals and tree roots travel through the ground. All three of these travelers chose the path of least resistance. They naturally avoid, or travel around, obstacles in their path.

In circuits, there are many factors that can affect flow in the ground plane. For example, the purity of the metal composing the plane and the consistency with which is it applied to the printed circuit board. There are vias connecting to or through the ground plane. There are currents from other ICs making their way through ground to the power supply.

Ever wonder why we place bypass capacitors as close to the IC as possible? They provide a high-frequency path to short any high frequencies that may exist or even be gathered on the power supply line. (A copper wire is a fine dipole antenna. The frequencies it picks up are strongly dependent on the length of the trace and/or wire.) Earlier we referenced the practice of probing nodes with a DMM. When referring to the placement of bypass capacitors, it would be more revealing to probe with an oscilloscope. Not only will you find frequencies that circulate in your system, you will likely find signals from local radio stations or one of the many wireless transmissions surrounding our everyday lives. These are the signals that

couple in through longer traces and wreak havoc on the operations of our systems. Not only do they exist on power supply lines, they circulate in the ground, too.

An example of bypass capacitor placement is shown in Figure 1. The SOT-23 package pads in the center will hold an op amp. There is a bypass capacitor connected on each of the dual supply pins. Notice that the opposite sides of the capacitors are connected to ground. The ground connection is not a long wire eventually connecting to the ground plane. Instead, a large rectangle of top layer metal allows high frequency currents to easily coast through two nearby vias to the ground plane.

Once the unwanted signals reach the ground plane, they don't magically disappear. They continue to travel through the ground plane. It is on this journey that they can couple into other signals in the system and affect more than just the IC with the long trace. To see how the current travels, refer to Figure 2. You'll notice that the op amp layout in Figure 1 is duplicated twice on the inputs of the circuit in Figure 2. We now follow the current through the ground connection we highlighted as a common connection between the bypass capacitors in Figure 1. The majority of the current takes a direct path to the ground pins of the input connector. However, notice how the density of the current spreads. It travels in a wider arc that you might imagine. Now superimpose the paths of signals through every other ground via back to the connector grounds. (If we tried to draw them all on another figure, it would look more like fireworks.) That is how signals from one IC couple to another and how interference signals can couple into every part of your system.

Notice that two characteristics will affect the spreading of the current and the shape of the return path. The first is distance. The drive to make consumer products smaller greatly helps with this aspect. However, as the printed circuit boards get smaller, the devices get closer together. Distance is reduced, but now the multiple ground return paths are closer together. When the fringes of current overlap, the signals intertwine.

What can we do? Careful layout is a must. Keep high frequency circuitry as compact as possible. You might even choose to isolate these devices with metal traces or cuts in ground planes. Figure 3 gives you an example. The return current of input A no longer overlaps with the return current of input B. In this case, knowing the nonideal nature of ground allows us to improve the operation of our system. A full ground "plane" will not work as well as one with cuts to guide the return current. If we had assumed ground was ideal, we would have not have been able to make this improvement.

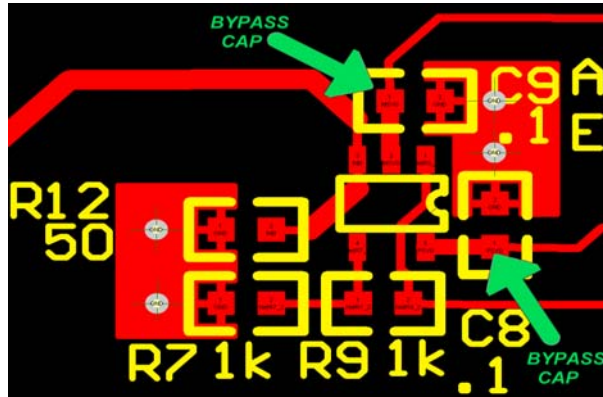

FIGURE 1. THE LOCATION OF BYPASS CAPACITORS ARE HIGHLIGHTED IN A LAYOUT OF AN OP AMP IN A SOT-23 PACKAGE

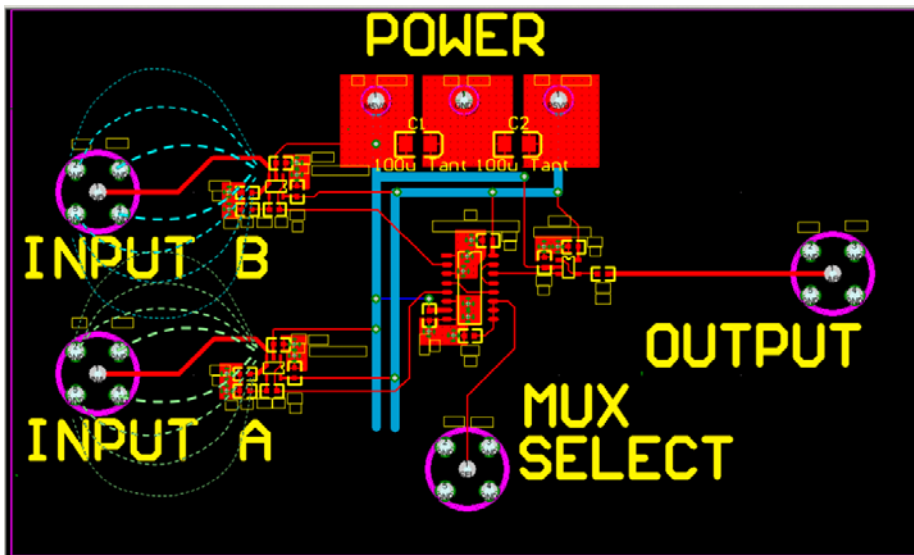

FIGURE 2. AN EXAMPLE PRINTED CIRCUIT BOARD LAYOUT WITH TWO INPUTS TO TWO SEPARATE OP AMPS FEEDING A MULTIPLEXER. THE GREEN DASHED LINES SHOW AN EXAMPLE PATH THAT SIGNALS TAKE THROUGH THE GROUND PLANE BACK TO THE GROUND PINS OF THE INPUT CONNECTOR. THE LONGER THE GREEN DASHES, THE HIGHER THE CONCENTRATION OF GROUND CURRENT

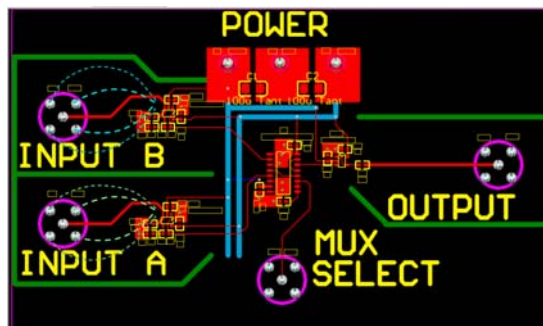

FIGURE 3. CUT-OUTS IN THE GROUND PLANCE ELIMINATE ANY CROSSTALK BETWEEN THE RETURN GROUND PATHS OF INPUT A AND INPUT B

Notice

1. Descriptions of circuits, software and other related information in this document are provided only to illustrate the operation of semiconductor products and application examples. You are fully responsible for the incorporation or any other use of the circuits, software, and information in the design of your product or system. Renesas Electronics disclaims any and all liability for any losses and damages incurred by you or third parties arising from the use of these circuits, software, or information.
2. Renesas Electronics hereby expressly disclaims any warranties against and liability for infringement or any other claims involving patents, copyrights, or other intellectual property rights of third parties, by or arising from the use of Renesas Electronics products or technical information described in this document, including but not limited to, the product data, drawings, charts, programs, algorithms, and application examples.
3. No license, express, implied or otherwise, is granted hereby under any patents, copyrights or other intellectual property rights of Renesas Electronics or others.
4. You shall not alter, modify, copy, or reverse engineer any Renesas Electronics product, whether in whole or in part. Renesas Electronics disclaims any and all liability for any losses or damages incurred by you or third parties arising from such alteration, modification, copying or reverse engineering.
5. Renesas Electronics products are classified according to the following two quality grades: "Standard" and "High Quality". The intended applications for each Renesas Electronics product depends on the product's quality grade, as indicated below.
"Standard": Computers; office equipment; communications equipment; test and measurement equipment; audio and visual equipment; home electronic appliances; machine tools; personal electronic equipment; industrial robots; etc.
"High Quality": Transportation equipment (automobiles, trains, ships, etc.); traffic control (traffic lights); large-scale communication equipment; key financial terminal systems; safety control equipment; etc.
Unless expressly designated as a high reliability product or a product for harsh environments in a Renesas Electronics data sheet or other Renesas Electronics document, Renesas Electronics products are not intended or authorized for use in products or systems that may pose a direct threat to human life or bodily injury (artificial life support devices or systems; surgical implantations; etc.), or may cause serious property damage (space system; undersea repeaters; nuclear power control systems; aircraft control systems; key plant systems; military equipment; etc.). Renesas Electronics disclaims any and all liability for any damages or losses incurred by you or any third parties arising from the use of any Renesas Electronics product that is inconsistent with any Renesas Electronics data sheet, user's manual or other Renesas Electronics document.
6. When using Renesas Electronics products, refer to the latest product information (data sheets, user's manuals, application notes, "General Notes for Handling and Using Semiconductor Devices" in the reliability handbook, etc.), and ensure that usage conditions are within the ranges specified by Renesas Electronics with respect to maximum ratings, operating power supply voltage range, heat dissipation characteristics, installation, etc. Renesas Electronics disclaims any and all liability for any malfunctions, failure or accident arising out of the use of Renesas Electronics products outside of such specified ranges.
7. Although Renesas Electronics endeavors to improve the quality and reliability of Renesas Electronics products, semiconductor products have specific characteristics, such as the occurrence of failure at a certain rate and malfunctions under certain use conditions. Unless designated as a high reliability product or a product for harsh environments in a Renesas Electronics data sheet or other Renesas Electronics document, Renesas Electronics products are not subject to radiation resistance design. You are responsible for implementing safety measures to guard against the possibility of bodily injury, injury or damage caused by fire, and/or danger to the public in the event of a failure or malfunction of Renesas Electronics products, such as safety design for hardware and software, including but not limited to redundancy, fire control and malfunction prevention, appropriate treatment for aging degradation or any other appropriate measures. Because the evaluation of microcomputer software alone is very difficult and impractical, you are responsible for evaluating the safety of the final products or systems manufactured by you.
8. Please contact a Renesas Electronics sales office for details as to environmental matters such as the environmental compatibility of each Renesas Electronics product. You are responsible for carefully and sufficiently investigating applicable laws and regulations that regulate the inclusion or use of controlled substances, including without limitation, the EU RoHS Directive, and using Renesas Electronics products in compliance with all these applicable laws and regulations. Renesas Electronics disclaims any and all liability for damages or losses occurring as a result of your noncompliance with applicable laws and regulations.
9. Renesas Electronics products and technologies shall not be used for or incorporated into any products or systems whose manufacture, use, or sale is prohibited under any applicable domestic or foreign laws or regulations. You shall comply with any applicable export control laws and regulations promulgated and administered by the governments of any countries asserting jurisdiction over the parties or transactions.
10. It is the responsibility of the buyer or distributor of Renesas Electronics products, or any other party who distributes, disposes of, or otherwise sells or transfers the product to a third party, to notify such third party in advance of the contents and conditions set forth in this document.
11. This document shall not be reprinted, reproduced or duplicated in any form, in whole or in part, without prior written consent of Renesas Electronics.
12. Please contact a Renesas Electronics sales office if you have any questions regarding the information contained in this document or Renesas Electronics products.
(Note 1) "Renesas Electronics" as used in this document means Renesas Electronics Corporation and also includes its directly or indirectly controlled subsidiaries.
(Note 2) "Renesas Electronics product(s)" means any product developed or manufactured by or for Renesas Electronics.

(Rev.4.0-1 November 2017)



SALES OFFICES

Renesas Electronics Corporation

<http://www.renesas.com>

Refer to "<http://www.renesas.com/>" for the latest and detailed information.

Renesas Electronics America Inc.
1001 Murphy Ranch Road, Milpitas, CA 95035, U.S.A.
Tel: +1-408-432-8888, Fax: +1-408-434-5351

Renesas Electronics Canada Limited
9251 Yonge Street, Suite 8309 Richmond Hill, Ontario Canada L4C 9T3
Tel: +1-905-237-2004

Renesas Electronics Europe Limited
Dukes Meadow, Millboard Road, Bourne End, Buckinghamshire, SL8 5FH, U.K
Tel: +44-1628-651-700, Fax: +44-1628-651-804

Renesas Electronics Europe GmbH
Arcadiastrasse 10, 40472 Düsseldorf, Germany
Tel: +49-211-6503-0, Fax: +49-211-6503-1327

Renesas Electronics (China) Co., Ltd.
Room 1709 Quantum Plaza, No.27 ZhichunLu, Haidian District, Beijing, 100191 P. R. China
Tel: +86-10-8235-1155, Fax: +86-10-8235-7679

Renesas Electronics (Shanghai) Co., Ltd.
Unit 301, Tower A, Central Towers, 555 Langao Road, Putuo District, Shanghai, 200333 P. R. China
Tel: +86-21-2226-0888, Fax: +86-21-2226-0999

Renesas Electronics Hong Kong Limited
Unit 1601-1611, 16/F., Tower 2, Grand Century Place, 193 Prince Edward Road West, Mongkok, Kowloon, Hong Kong
Tel: +852-2265-6688, Fax: +852-2886-9022

Renesas Electronics Taiwan Co., Ltd.
13F, No. 363, Fu Shing North Road, Taipei 10543, Taiwan
Tel: +886-2-8175-9600, Fax: +886-2-8175-9670

Renesas Electronics Singapore Pte. Ltd.
80 Bendemeer Road, Unit #06-02 Hyflux Innovation Centre, Singapore 339949
Tel: +65-6213-0200, Fax: +65-6213-0300

Renesas Electronics Malaysia Sdn.Bhd.
Unit 1207, Block B, Menara Amcorp, Amcorp Trade Centre, No. 18, Jln Persiaran Barat, 46050 Petaling Jaya, Selangor Darul Ehsan, Malaysia
Tel: +60-3-7955-9390, Fax: +60-3-7955-9510

Renesas Electronics India Pvt. Ltd.
No.777C, 100 Feet Road, HAL 2nd Stage, Indiranagar, Bangalore 560 038, India
Tel: +91-80-67208700, Fax: +91-80-67208777

Renesas Electronics Korea Co., Ltd.
17F, KAMCO Yangjae Tower, 262, Gangnam-daero, Gangnam-gu, Seoul, 06265 Korea
Tel: +82-2-558-3737, Fax: +82-2-558-5338