

Grounding Techniques

Ground is taken for granted. We stand on it, we dig into it, we make mud pies out of it. The ground isn't supposed to move. We don't have to think about it; it just is. When it comes to grounding a circuit, we assume that our connections are as solid as the turf below our scuffed shoes. Many times, this is a reasonable assumption-but not always. How do we know when there is a problem with a circuit's ground? What practices will ensure we construct a good ground?

No longer to be taken for granted, we define ground in ideal and real situations. Ground configurations and printed circuit board (PCB) examples will be presented.

Ground Terminology

Many nodes are called "ground". There are floating grounds, virtual grounds, AC grounds and earth grounds. For clarity, let's look at the difference.

- Floating grounds are reference points within an isolated system. They are a reference point and only equal to 0 volts through luck.
- Virtual grounds exist in a negative feedback circuit at the inverting terminal of an op amp. When the noninverting input is held at zero volts, the feedback (in a stable circuit) will cause the inverting terminal to match. The value is only held by feedback and is not a stable return for other circuit currents.
- AC grounds are nodes with low impedance DC values. That DC voltage is stable with small circuit perturbations. Since the node has a DC value, it is not useful as a proper ground. However, since it is stable, it is useful as a reference point. AC (or small-signal) analysis considers these points to be unchanging, thus like a ground.
- Earth ground is exactly what the words suggest. Every house has a copper pole sunk into the ground to deplete surplus currents. Without the presence of a buried battery, the top layer of turf is fairly homogeneous. A house down the street from yours might have a difference in ground voltage of a hundred microvolts. This is the type of ground we are going to discuss.

TABLE 1. COMPARISON OF VARIOUS TYPES OF ELECTRICAL GROUNDS

GROUND TERMINOLOGY	DEFINITION	CONNECTED TO EARTH GROUND	EXAMPLE
Floating Ground	Local reference potential	NO	Medical systems to protect patient
Virtual Ground	Node held at or near ground potential by feedback	NO	Negative input terminal on Inverting Op Amp
AC Ground	Node held at a constant DC potential	NO	V _{SUPPLY} , Bias voltage, Bandgap voltage
Reference/Earth Ground	System ground	YES	DIRECT CONNECTION to earth ground

What is Ground?

I asked a handful of fellow engineers to define "ground". A chorus of answers responded "Zero volts" or "Zero reference". A more extensive definition can be found on Answers.com™ [1], "a large conducting body (as the earth) used as a common return for an electric current and as an arbitrary zero of potential." This definition is particularly helpful because it refers to the role of ground in terms of voltage AND current.

To explore this dual role, let's look at an extremely simple circuit, Figure 1a. This circuit could represent a plethora of different systems-a flashlight, a coffee maker, or even an iPod. Figure 1b represents those circuits just as well. Of course, we don't typically think of ungrounding a circuit to turn it off, we think of disconnecting the power. The truth is, they are equally effective. The load and the switch are in series, so the order is irrelevant. An open switch stops the flow of current; zero current through the load means zero power in the load. (In practice, the circuit in Figure 1a is more common than Figure 1b for a practical reason-it is more likely that the system could accidentally become connected to ground (a loose wire to the chassis, for instance) causing unwanted power in the load than to accidentally become connected to the power supply.) The principle, however, is useful.

Those lines representing the connection between the source and load could be of a wide variety of lengths. They could be a few inches long, as in a household appliance, or they could be miles long, as in the power grid. In small systems, the assumption of a lossless wire is reasonable. As system sizes increase, the connections (wires, board traces, and interfaces) can no longer be considered lossless. An extreme example is the lines from the power company. Between the repeaters, the power is transmitted with high voltage (hundreds of kilovolts) and minimal current to negate losses caused by series resistance.

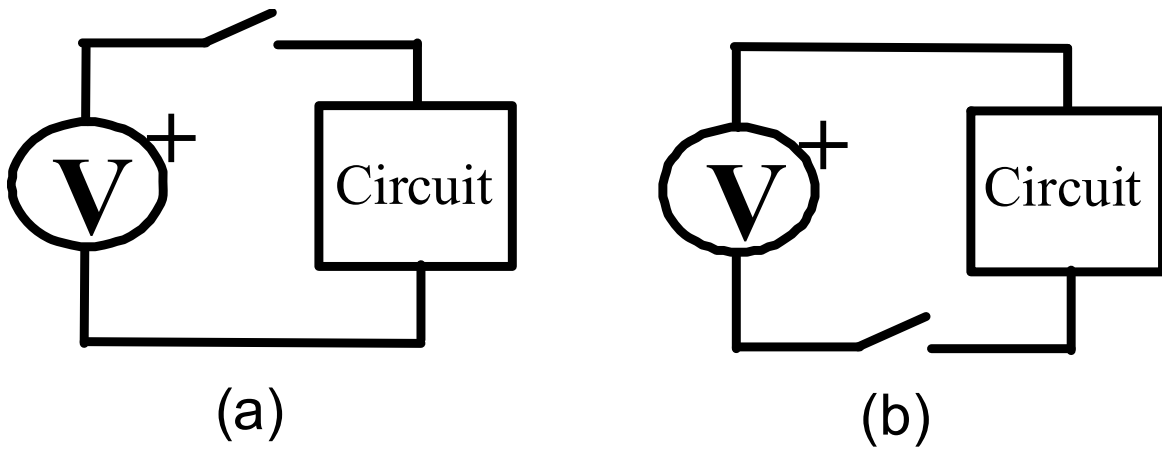

FIGURE 1. SIMPLE CIRCUIT. SWITCH CAN STOP THE FLOW OF CURRENT TO THE CIRCUIT OR AWAY

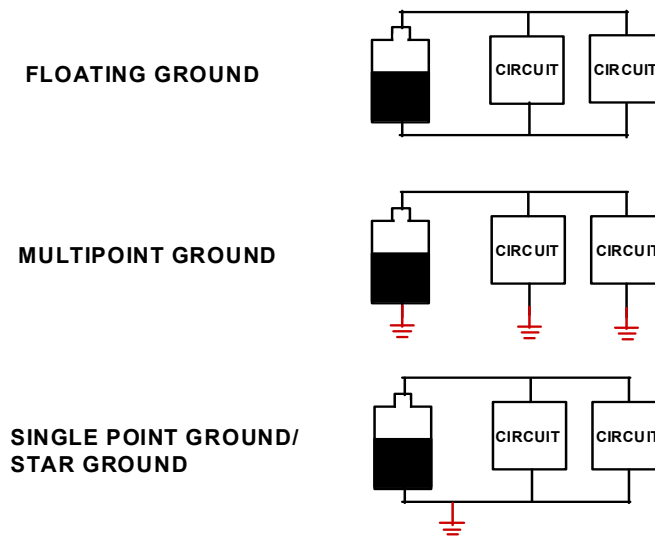

FIGURE 2. GROUNDING TOPOLOGIES: FLOATING GROUND, MUTLIPOINTGROUND, SINGLE-POINT GROUND

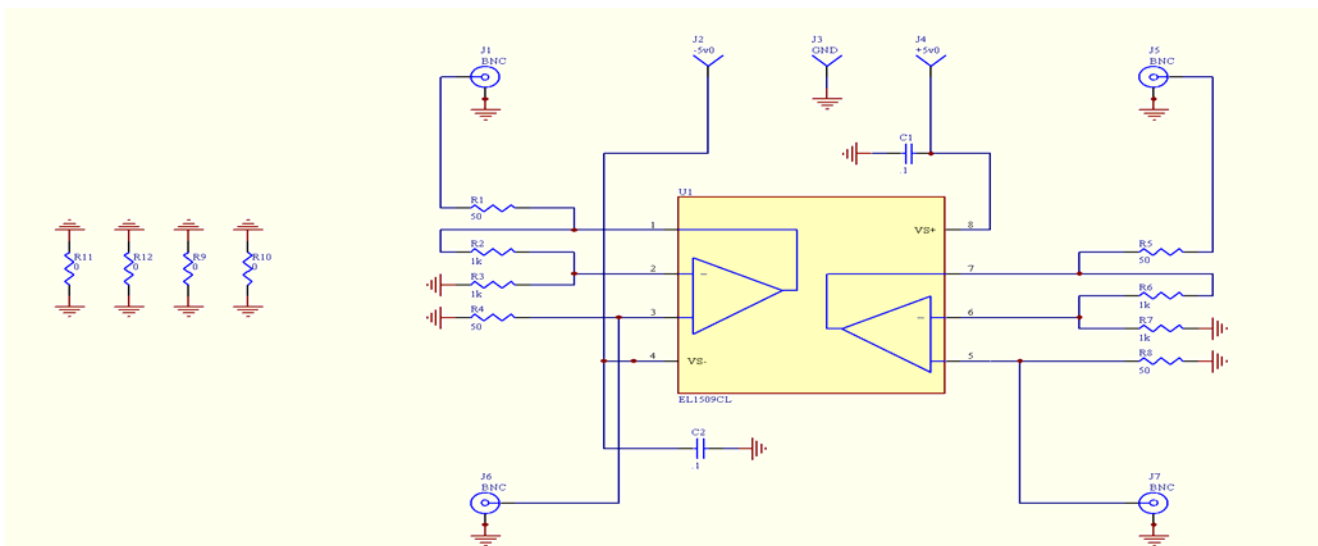

FIGURE 3. TEST CIRCUIT USED IN LAYOUTS FOR FIGURES 4-6

PCB Examples

A dual op amp is chosen as the layout example. For clarity, a single layer of copper is used for all routing (this is not the best choice for speed, isolation, coupling, etc.). Figure 3 shows the complete schematic used for each of the PCB examples.

Capacitors C1 and C2 are included to bypass the supply for the dual op amp package. Resistors R1, R4, R5, and R8 are matching resistors for terminating cables, assuming we are operating in a 50Ω environment. Resistors R2, R3, R6, and R7 set the amplifiers in a non-inverting configuration with a gain of 2. And lastly, because a single layer is used and a bit of wire-jumping is necessary, a few zero ohm resistors (R9-R12) have been included as well.

Figure 4 shows the first attempt to layout our circuit. The ground connection travels right down the center, providing a spine to our bilaterally symmetric creation. Sadly, though, both the positive and negative supplies travel in a large loop around both sides of the device. It's great that the layout is symmetric; it's not so great that the power lines loop around the board. These long, thin traces will act as antennas, picking up as much of the local RF noise as they can. In addition, the traces may have measurable IR drop in them-another downside.

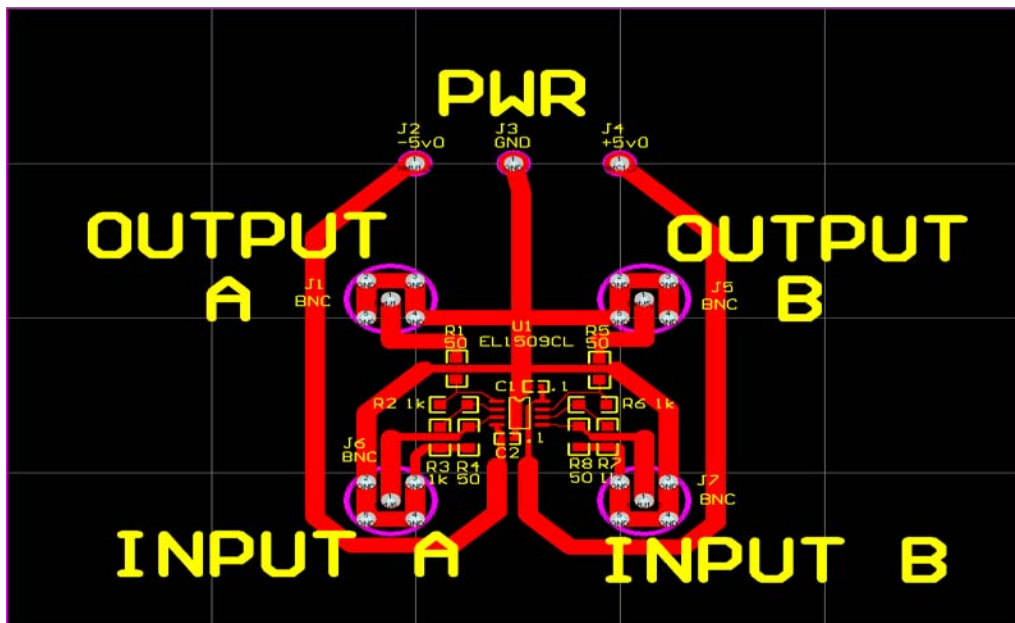

FIGURE 4. WIRED GROUND LAYOUT

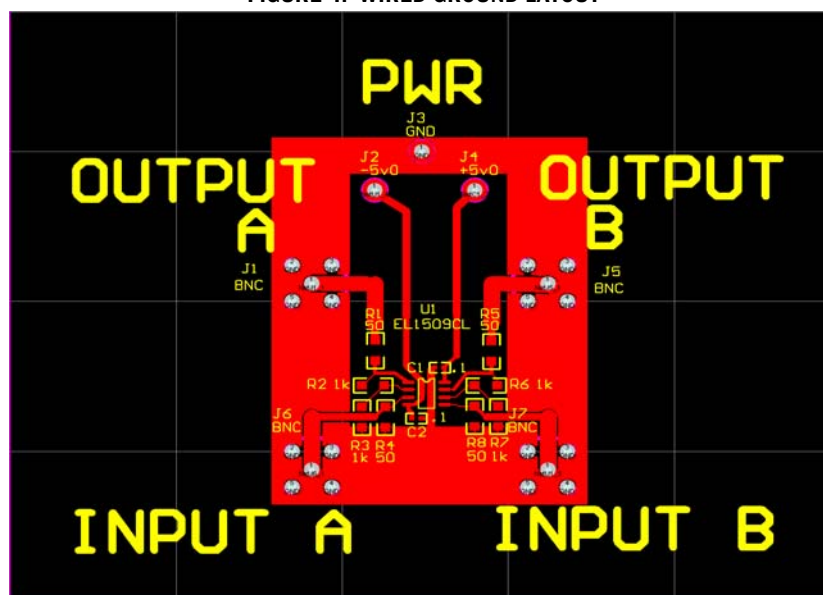

FIGURE 5. OUTER GROUND PLANE

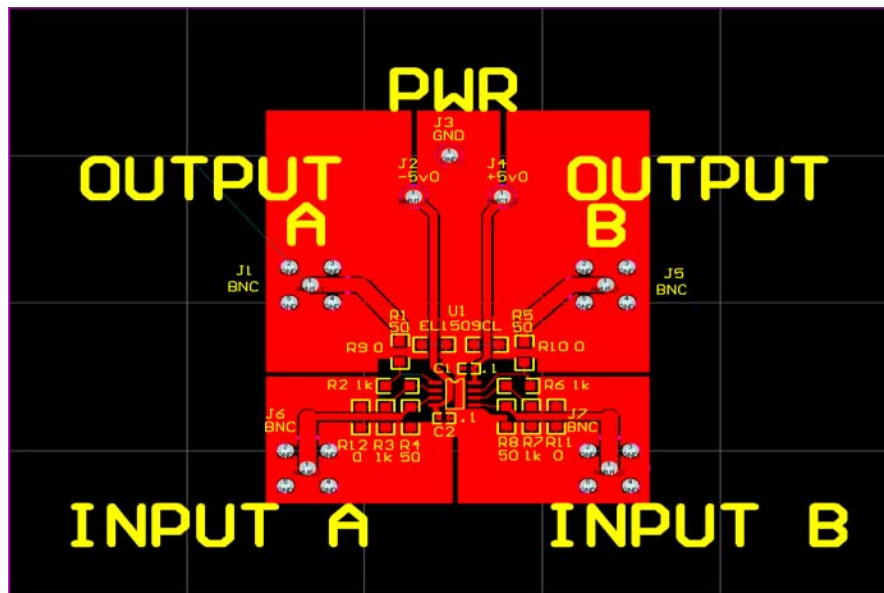

FIGURE 6. SPLIT/STAR GROUND PLANE

The next attempt at layout is shown in Figure 5. In a single-layer board, this is a close approximation to having a “ground plane”. This time the ground loops around the outside of the board. A connection to ground is made every time it is needed. This could be considered a multi-point ground. Instead of a thin trace, though, the ground connection is wide (considerably lower impedance). However, any noise that couples into either power supply will still be radiated from the area of the loop created by the power trace and the ground connection.

Figure 6 shows our best layout. Ground once again forms a plane around the device, but there are 5 slices keeping it from being continuous. Notice that each of the ground planes connects to the others, but only at one place. This is an example of a single-point or star ground. Currents cannot travel haphazardly throughout the ground plane; they are steered through specific paths we create and control. This type of set-up will minimize any antenna characteristics, both emitting and receiving.

These examples offer a bit of insight into the types of grounding schemes and how they appear on a printed circuit board. The best advice is to “follow the currents”:

- The longer a current has to travel, the more trouble it can cause. It is the best policy to keep wide, low-impedance ground connections as close to the devices as possible.
- Multiple currents can interact. If multiple loops overlap, break up the ground connection to minimize coupling.
- Don't forget the return currents! Every current leaving a node must return via some path. If the forward and return paths are very close (enclosed in a small area) the external fields cancel. If not, you have an antenna.

References

- [1] Answers.com. October 20, 2011.
<<http://www.answers.com/topic/ground>>.

Notice

1. Descriptions of circuits, software and other related information in this document are provided only to illustrate the operation of semiconductor products and application examples. You are fully responsible for the incorporation or any other use of the circuits, software, and information in the design of your product or system. Renesas Electronics disclaims any and all liability for any losses and damages incurred by you or third parties arising from the use of these circuits, software, or information.
2. Renesas Electronics hereby expressly disclaims any warranties against and liability for infringement or any other claims involving patents, copyrights, or other intellectual property rights of third parties, by or arising from the use of Renesas Electronics products or technical information described in this document, including but not limited to, the product data, drawings, charts, programs, algorithms, and application examples.
3. No license, express, implied or otherwise, is granted hereby under any patents, copyrights or other intellectual property rights of Renesas Electronics or others.
4. You shall not alter, modify, copy, or reverse engineer any Renesas Electronics product, whether in whole or in part. Renesas Electronics disclaims any and all liability for any losses or damages incurred by you or third parties arising from such alteration, modification, copying or reverse engineering.
5. Renesas Electronics products are classified according to the following two quality grades: "Standard" and "High Quality". The intended applications for each Renesas Electronics product depends on the product's quality grade, as indicated below.
"Standard": Computers; office equipment; communications equipment; test and measurement equipment; audio and visual equipment; home electronic appliances; machine tools; personal electronic equipment; industrial robots; etc.
"High Quality": Transportation equipment (automobiles, trains, ships, etc.); traffic control (traffic lights); large-scale communication equipment; key financial terminal systems; safety control equipment; etc.
Unless expressly designated as a high reliability product or a product for harsh environments in a Renesas Electronics data sheet or other Renesas Electronics document, Renesas Electronics products are not intended or authorized for use in products or systems that may pose a direct threat to human life or bodily injury (artificial life support devices or systems; surgical implantations; etc.), or may cause serious property damage (space system; undersea repeaters; nuclear power control systems; aircraft control systems; key plant systems; military equipment; etc.). Renesas Electronics disclaims any and all liability for any damages or losses incurred by you or any third parties arising from the use of any Renesas Electronics product that is inconsistent with any Renesas Electronics data sheet, user's manual or other Renesas Electronics document.
6. When using Renesas Electronics products, refer to the latest product information (data sheets, user's manuals, application notes, "General Notes for Handling and Using Semiconductor Devices" in the reliability handbook, etc.), and ensure that usage conditions are within the ranges specified by Renesas Electronics with respect to maximum ratings, operating power supply voltage range, heat dissipation characteristics, installation, etc. Renesas Electronics disclaims any and all liability for any malfunctions, failure or accident arising out of the use of Renesas Electronics products outside of such specified ranges.
7. Although Renesas Electronics endeavors to improve the quality and reliability of Renesas Electronics products, semiconductor products have specific characteristics, such as the occurrence of failure at a certain rate and malfunctions under certain use conditions. Unless designated as a high reliability product or a product for harsh environments in a Renesas Electronics data sheet or other Renesas Electronics document, Renesas Electronics products are not subject to radiation resistance design. You are responsible for implementing safety measures to guard against the possibility of bodily injury, injury or damage caused by fire, and/or danger to the public in the event of a failure or malfunction of Renesas Electronics products, such as safety design for hardware and software, including but not limited to redundancy, fire control and malfunction prevention, appropriate treatment for aging degradation or any other appropriate measures. Because the evaluation of microcomputer software alone is very difficult and impractical, you are responsible for evaluating the safety of the final products or systems manufactured by you.
8. Please contact a Renesas Electronics sales office for details as to environmental matters such as the environmental compatibility of each Renesas Electronics product. You are responsible for carefully and sufficiently investigating applicable laws and regulations that regulate the inclusion or use of controlled substances, including without limitation, the EU RoHS Directive, and using Renesas Electronics products in compliance with all these applicable laws and regulations. Renesas Electronics disclaims any and all liability for damages or losses occurring as a result of your noncompliance with applicable laws and regulations.
9. Renesas Electronics products and technologies shall not be used for or incorporated into any products or systems whose manufacture, use, or sale is prohibited under any applicable domestic or foreign laws or regulations. You shall comply with any applicable export control laws and regulations promulgated and administered by the governments of any countries asserting jurisdiction over the parties or transactions.
10. It is the responsibility of the buyer or distributor of Renesas Electronics products, or any other party who distributes, disposes of, or otherwise sells or transfers the product to a third party, to notify such third party in advance of the contents and conditions set forth in this document.
11. This document shall not be reprinted, reproduced or duplicated in any form, in whole or in part, without prior written consent of Renesas Electronics.
12. Please contact a Renesas Electronics sales office if you have any questions regarding the information contained in this document or Renesas Electronics products.
(Note 1) "Renesas Electronics" as used in this document means Renesas Electronics Corporation and also includes its directly or indirectly controlled subsidiaries.
(Note 2) "Renesas Electronics product(s)" means any product developed or manufactured by or for Renesas Electronics.

(Rev.4.0-1 November 2017)



SALES OFFICES

Renesas Electronics Corporation

<http://www.renesas.com>

Refer to "<http://www.renesas.com/>" for the latest and detailed information.

Renesas Electronics America Inc.
1001 Murphy Ranch Road, Milpitas, CA 95035, U.S.A.
Tel: +1-408-432-8888, Fax: +1-408-434-5351

Renesas Electronics Canada Limited
9251 Yonge Street, Suite 8309 Richmond Hill, Ontario Canada L4C 9T3
Tel: +1-905-237-2004

Renesas Electronics Europe Limited
Dukes Meadow, Millboard Road, Bourne End, Buckinghamshire, SL8 5FH, U.K.
Tel: +44-1628-651-700, Fax: +44-1628-651-804

Renesas Electronics Europe GmbH
Arcadiastrasse 10, 40472 Düsseldorf, Germany
Tel: +49-211-6503-0, Fax: +49-211-6503-1327

Renesas Electronics (China) Co., Ltd.
Room 1709 Quantum Plaza, No.27 ZhichunLu, Haidian District, Beijing, 100191 P. R. China
Tel: +86-10-8235-1155, Fax: +86-10-8235-7679

Renesas Electronics (Shanghai) Co., Ltd.
Unit 301, Tower A, Central Towers, 555 Langao Road, Putuo District, Shanghai, 200333 P. R. China
Tel: +86-21-2226-0888, Fax: +86-21-2226-0999

Renesas Electronics Hong Kong Limited
Unit 1601-1611, 16/F., Tower 2, Grand Century Place, 193 Prince Edward Road West, Mongkok, Kowloon, Hong Kong
Tel: +852-2265-6688, Fax: +852-2886-9022

Renesas Electronics Taiwan Co., Ltd.
13F, No. 363, Fu Shing North Road, Taipei 10543, Taiwan
Tel: +886-2-8175-9600, Fax: +886-2-8175-9670

Renesas Electronics Singapore Pte. Ltd.
80 Bendemeer Road, Unit #06-02 Hyflux Innovation Centre, Singapore 339949
Tel: +65-6213-0200, Fax: +65-6213-0300

Renesas Electronics Malaysia Sdn.Bhd.
Unit 1207, Block B, Menara Amcorp, Amcorp Trade Centre, No. 18, Jln Persiaran Barat, 46050 Petaling Jaya, Selangor Darul Ehsan, Malaysia
Tel: +60-3-7955-9390, Fax: +60-3-7955-9510

Renesas Electronics India Pvt. Ltd.
No.777C, 100 Feet Road, HAL 2nd Stage, Indiranagar, Bangalore 560 038, India
Tel: +91-80-67208700, Fax: +91-80-67208777

Renesas Electronics Korea Co., Ltd.
17F, KAMCO Yangjae Tower, 262, Gangnam-daero, Gangnam-gu, Seoul, 06265 Korea
Tel: +82-2-558-3737, Fax: +82-2-558-5338