

Description

The HXT45430 is a quad-channel linear optical modulator driver array, and is a member of the Datacom family of Optical Receiver Transmitter Array (ORTA) products. In conjunction with a Silicon Photonics modulator or other external modulator such as EML, a compact linear transmitter can be designed for the next generation of 200G/400G optical transceivers.

The HXT45430 is a low-power, high-performance, quad-channel linear driver, designed for 4×112Gb/s PAM4 Silicon Photonics-based transceivers. The driver has differential inputs and outputs consisting of 4×56Gbaud broadband amplifier channels, each capable of driving a linear output voltage of 4.0V_{ppd}, suitable for 4λ 400G PAM-4 applications.

Features

- Data baud rate up to 56Gbaud per channel for PAM-4 applications
- > 40GHz Bandwidth
- > 10dB dynamic range of gain control
- 1.6W power consumption at linear 3.0V_{ppd} output
- DC-coupled 100Ω differential input
- Open collector configuration at output
- Ultra-low inter-channel cross-talk
- Peaking adjustment functionality
- Analog control for gain and output voltage setting, and analog monitor for peak detector and gain control monitor
- OIF compliant SPI digital interface available

Typical Applications

- 400GBASE-DR4 and FR4 Ethernet transceivers
- 200G/400G QSFP-DD or OSFP or 400G OBO

Block Diagram

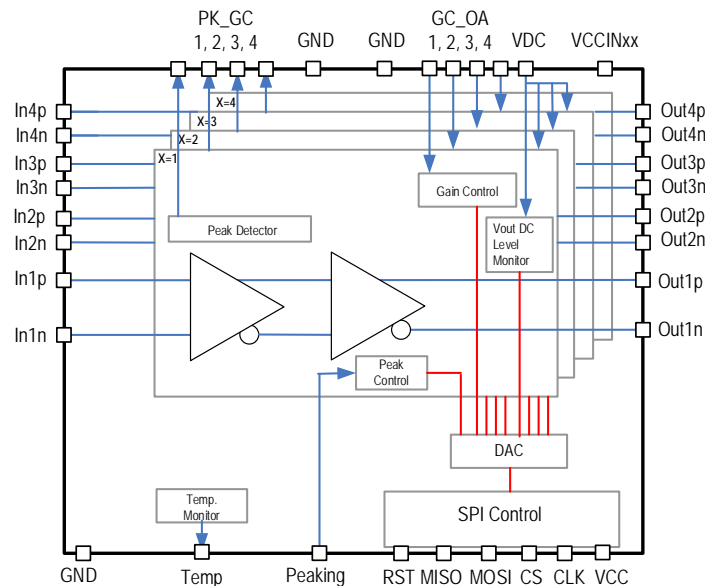

Figure 1: Block Diagram

Ordering Information

Orderable Part Number	Die Package Size (mm)	Temperature (°C)
HXT45430-DNU	2.015 x 3.995 x 0.3	-5°C to +105°C

IMPORTANT NOTICE AND DISCLAIMER

RENESAS ELECTRONICS CORPORATION AND ITS SUBSIDIARIES (“RENESAS”) PROVIDES TECHNICAL SPECIFICATIONS AND RELIABILITY DATA (INCLUDING DATASHEETS), DESIGN RESOURCES (INCLUDING REFERENCE DESIGNS), APPLICATION OR OTHER DESIGN ADVICE, WEB TOOLS, SAFETY INFORMATION, AND OTHER RESOURCES “AS IS” AND WITH ALL FAULTS, AND DISCLAIMS ALL WARRANTIES, EXPRESS OR IMPLIED, INCLUDING, WITHOUT LIMITATION, ANY IMPLIED WARRANTIES OF MERCHANTABILITY, FITNESS FOR A PARTICULAR PURPOSE, OR NON-INFRINGEMENT OF THIRD PARTY INTELLECTUAL PROPERTY RIGHTS.

These resources are intended for developers skilled in the art designing with Renesas products. You are solely responsible for (1) selecting the appropriate products for your application, (2) designing, validating, and testing your application, and (3) ensuring your application meets applicable standards, and any other safety, security, or other requirements. These resources are subject to change without notice. Renesas grants you permission to use these resources only for development of an application that uses Renesas products. Other reproduction or use of these resources is strictly prohibited. No license is granted to any other Renesas intellectual property or to any third party intellectual property. Renesas disclaims responsibility for, and you will fully indemnify Renesas and its representatives against, any claims, damages, costs, losses, or liabilities arising out of your use of these resources. Renesas' products are provided only subject to Renesas' Terms and Conditions of Sale or other applicable terms agreed to in writing. No use of any Renesas resources expands or otherwise alters any applicable warranties or warranty disclaimers for these products.

(Disclaimer Rev.1.0 Mar 2020)

Corporate Headquarters

TOYOSU FORESIA, 3-2-24 Toyosu,
Koto-ku, Tokyo 135-0061, Japan
www.renesas.com

Contact Information

For further information on a product, technology, the most up-to-date version of a document, or your nearest sales office, please visit:
www.renesas.com/contact/

Trademarks

Renesas and the Renesas logo are trademarks of Renesas Electronics Corporation. All trademarks and registered trademarks are the property of their respective owners.