

V850E2/PG4-L

User's Manual: Hardware

Renesas microcomputers
V850 Series

All information contained in these materials, including products and product specifications, represents information on the product at the time of publication and is subject to change by Renesas Electronics Corp. without notice. Please review the latest information published by Renesas Electronics Corp. through various means, including the Renesas Electronics Corp. website (<http://www.renesas.com>).

Notice

1. Descriptions of circuits, software and other related information in this document are provided only to illustrate the operation of semiconductor products and application examples. You are fully responsible for the incorporation of these circuits, software, and information in the design of your equipment. Renesas Electronics assumes no responsibility for any losses incurred by you or third parties arising from the use of these circuits, software, or information.
2. Renesas Electronics has used reasonable care in preparing the information included in this document, but Renesas Electronics does not warrant that such information is error free. Renesas Electronics assumes no liability whatsoever for any damages incurred by you resulting from errors in or omissions from the information included herein.
3. Renesas Electronics does not assume any liability for infringement of patents, copyrights, or other intellectual property rights of third parties by or arising from the use of Renesas Electronics products or technical information described in this document. No license, express, implied or otherwise, is granted hereby under any patents, copyrights or other intellectual property rights of Renesas Electronics or others.
4. You should not alter, modify, copy, or otherwise misappropriate any Renesas Electronics product, whether in whole or in part. Renesas Electronics assumes no responsibility for any losses incurred by you or third parties arising from such alteration, modification, copy or otherwise misappropriation of Renesas Electronics product.
5. Renesas Electronics products are classified according to the following two quality grades: "Standard" and "High Quality". The recommended applications for each Renesas Electronics product depends on the product's quality grade, as indicated below.
"Standard": Computers; office equipment; communications equipment; test and measurement equipment; audio and visual equipment; home electronic appliances; machine tools; personal electronic equipment; and industrial robots etc.
"High Quality": Transportation equipment (automobiles, trains, ships, etc.); traffic control systems; anti-disaster systems; anti-crime systems; and safety equipment etc.

Renesas Electronics products are neither intended nor authorized for use in products or systems that may pose a direct threat to human life or bodily injury (artificial life support devices or systems, surgical implantations etc.), or may cause serious property damages (nuclear reactor control systems, military equipment etc.). You must check the quality grade of each Renesas Electronics product before using it in a particular application. You may not use any Renesas Electronics product for any application for which it is not intended. Renesas Electronics shall not be in any way liable for any damages or losses incurred by you or third parties arising from the use of any Renesas Electronics product for which the product is not intended by Renesas Electronics.
6. You should use the Renesas Electronics products described in this document within the range specified by Renesas Electronics, especially with respect to the maximum rating, operating supply voltage range, movement power voltage range, heat radiation characteristics, installation and other product characteristics. Renesas Electronics shall have no liability for malfunctions or damages arising out of the use of Renesas Electronics products beyond such specified ranges.
7. Although Renesas Electronics endeavors to improve the quality and reliability of its products, semiconductor products have specific characteristics such as the occurrence of failure at a certain rate and malfunctions under certain use conditions. Further, Renesas Electronics products are not subject to radiation resistance design. Please be sure to implement safety measures to guard them against the possibility of physical injury, and injury or damage caused by fire in the event of the failure of a Renesas Electronics product, such as safety design for hardware and software including but not limited to redundancy, fire control and malfunction prevention, appropriate treatment for aging degradation or any other appropriate measures. Because the evaluation of microcomputer software alone is very difficult, please evaluate the safety of the final products or systems manufactured by you.
8. Please contact a Renesas Electronics sales office for details as to environmental matters such as the environmental compatibility of each Renesas Electronics product. Please use Renesas Electronics products in compliance with all applicable laws and regulations that regulate the inclusion or use of controlled substances, including without limitation, the EU RoHS Directive. Renesas Electronics assumes no liability for damages or losses occurring as a result of your noncompliance with applicable laws and regulations.
9. Renesas Electronics products and technology may not be used for or incorporated into any products or systems whose manufacture, use, or sale is prohibited under any applicable domestic or foreign laws or regulations. You should not use Renesas Electronics products or technology described in this document for any purpose relating to military applications or use by the military, including but not limited to the development of weapons of mass destruction. When exporting the Renesas Electronics products or technology described in this document, you should comply with the applicable export control laws and regulations and follow the procedures required by such laws and regulations.
10. It is the responsibility of the buyer or distributor of Renesas Electronics products, who distributes, disposes of, or otherwise places the product with a third party, to notify such third party in advance of the contents and conditions set forth in this document, Renesas Electronics assumes no responsibility for any losses incurred by you or third parties as a result of unauthorized use of Renesas Electronics products.
11. This document may not be reproduced or duplicated in any form, in whole or in part, without prior written consent of Renesas Electronics.
12. Please contact a Renesas Electronics sales office if you have any questions regarding the information contained in this document or Renesas Electronics products, or if you have any other inquiries.

(Note 1) "Renesas Electronics" as used in this document means Renesas Electronics Corporation and also includes its majority-owned subsidiaries.

(Note 2) "Renesas Electronics product(s)" means any product developed or manufactured by or for Renesas Electronics.

Notes for CMOS devices

- (1) Voltage application waveform at input pin:** Waveform distortion due to input noise or a reflected wave may cause malfunction. If the input of the CMOS device stays in the area between V_{IL} (MAX) and V_{IH} (MIN) due to noise, etc., the device may malfunction. Take care to prevent chattering noise from entering the device when the input level is fixed, and also in the transition period when the input level passes through the area between V_{IL} (MAX) and V_{IH} (MIN).
- (2) Handling of unused input pins:** Unconnected CMOS device inputs can be cause of malfunction. If an input pin is unconnected, it is possible that an internal input level may be generated due to noise, etc., causing malfunction. CMOS devices behave differently than Bipolar or NMOS devices. Input levels of CMOS devices must be fixed high or low by using pull-up or pull-down circuitry. Each unused pin should be connected to VDD or GND via a resistor if there is a possibility that it will be an output pin. All handling related to unused pins must be judged separately for each device and according to related specifications governing the device.
- (3) Precaution against ESD:** A strong electric field, when exposed to a MOS device, can cause destruction of the gate oxide and ultimately degrade the device operation. Steps must be taken to stop generation of static electricity as much as possible, and quickly dissipate it when it has occurred. Environmental control must be adequate. When it is dry, a humidifier should be used. It is recommended to avoid using insulators that easily build up static electricity. Semiconductor devices must be stored and transported in an anti-static container, static shielding bag or conductive material. All test and measurement tools including work benches and floors should be grounded. The operator should be grounded using a wrist strap. Semiconductor devices must not be touched with bare hands. Similar precautions need to be taken for PW boards with mounted semiconductor devices.
- (4) Status before initialization:** Power-on does not necessarily define the initial status of a MOS device. Immediately after the power source is turned ON, devices with reset functions have not yet been initialized. Hence, power-on does not guarantee output pin levels, I/O settings or contents of registers. A device is not initialized until the reset signal is received. A reset operation must be executed immediately after power-on for devices with reset functions.
- (5) Power ON/OFF sequence:** In the case of a device that uses different power supplies for the internal operation and external interface, as a rule, switch on the external power supply after switching on the internal power supply. When switching the power supply off, as a rule, switch off the external power supply and then the internal power supply. Use of the reverse power on/off sequences may result in the application of an overvoltage to the internal elements of the device, causing malfunction and degradation of internal elements due to the passage of an abnormal current. The correct power on/off sequence must be judged separately for each device and according to related specifications governing the device.
- (6) Input of signal during power off state:** Do not input signals or an I/O pull-up power supply while the device is not powered. The current injection that results from input of such a signal or I/O pull-up power supply may cause malfunction and the abnormal current that passes in the device at this time may cause degradation of internal elements. Input of signals during the power off state must be judged separately for each device and according to related specifications governing the device.

How to Use This Manual

Readers This manual is intended for users who wish to understand the functions of the V850E2/PG4-L and design application systems using the following V850E2/PG4-L microcontrollers:

Purpose This manual is intended to give users an understanding of the hardware functions of the V850E2/PG4-L shown in the *Organization* below.

Organization This manual is divided into two parts: Hardware (this manual) and Architecture (V850E2M Architecture User's Manual).

Hardware	Architecture
Pin functions	Data types
CPU function	Register set
On-chip peripheral functions	Instruction format and instruction set
Flash memory programming	Interrupts and exceptions
	Pipeline operation

How to read this manual It is assumed that the readers of this manual have general knowledge in the fields of electrical engineering, logic circuits, and microcontrollers.

To understand the overall functions of the V850E2/PG4-L.

→ Read this manual according to the Contents.

To understand the details of an instruction function

→ See *V850E2M Architecture User's Manual* available separately.

Table of Contents

Section 1	Introduction	21
1.1	Overview	21
1.2	Characteristics	22
1.3	List of Functions	25
1.4	Field of Application	27
1.5	Information for Ordering	27
1.6	Pin Connection Diagram (Top View)	28
1.7	Configuration of Functional Blocks	34
1.7.1	Internal Block Diagram	34
1.7.2	Internal Units	35
Section 2	Port Functions	38
2.1	Port Functions	38
2.2	Overview	39
2.2.1	Terms	39
2.2.2	Pin Function Configuration	40
2.2.3	Pin Data Input/Output	43
2.2.4	Port Control Logic Diagram	45
2.3	Port Group Configuration Registers	46
2.3.1	Overview	46
2.3.2	Pin Function Configuration Registers	48
2.3.3	Pin Data Input/Output Registers	55
2.3.4	Configuration of Electrical Characteristics Registers	59
2.3.5	Port Register Protection	61
2.4	Port Group Configuration	63
2.4.1	List of Ports and Pins	64
2.5	Functions of Pull-Up and Pull-Down Resistors	84
2.5.1	Details of Pull-Up and Pull-Down Resistors	84
2.6	Port 0	89
2.6.1	Alternative Functions	89
2.6.2	List of Control Registers	90
2.7	Port 1	91
2.7.1	Alternative Functions	91
2.7.2	List of Control Registers	92
2.8	Port 2	93
2.8.1	Alternative Functions	93
2.8.2	List of Control Registers	94
2.9	Port 3	95
2.9.1	Alternative Functions	95

2.9.2	List of Control Registers	96
2.10	Port 4	97
2.10.1	Alternative Functions	97
2.10.2	List of Control Registers	98
2.11	Port 5	99
2.11.1	Alternative Functions	99
2.11.2	List of Control Registers	100
2.12	Port 8	101
2.12.1	Alternative Functions	101
2.12.2	List of Control Registers	101
2.13	JTAG Port 0	102
2.13.1	Alternative Functions	102
2.13.2	List of Control Registers	102
2.14	Cancelling Noise on Pins	103
2.14.1	Details of Noise Cancellation	103
2.14.2	Control Registers	109
2.15	Edge Detection	116
2.15.1	Details of Edge Detection	116
2.15.2	Control Register	117
Section 3	CPU System Function	118
3.1	Overview	118
3.1.1	Peripheral Protection Unit	120
3.1.2	Important Reminders	124
3.1.3	Timing Supervision Unit	124
3.2	Operation Modes	125
3.2.1	Normal Operation Mode	125
3.2.2	Flash Programming Mode	125
3.2.3	HALT Mode	126
3.3	Address Space	127
3.3.1	CPU Data Address and Physical Program Address Space	127
3.3.2	Program and Data Space	127
3.4	Conditions for Boundary Operations	129
3.4.1	Program Space	129
3.4.2	Data Space	129
3.5	Memory Mapping	130
3.5.1	Memory Map for DMA Access	130
3.5.2	Memory Map	131
3.6	CPU-Related Registers	132
3.6.1	Overview of CPU-Related Registers	132
3.6.2	CPU-Related Registers in Detail	133
3.7	System Error Notification Function	134
3.7.1	Overview of System Error Notification Registers	134

3.7.2	System Error Notification Function Registers in Detail.....	135
Section 4	Interrupt Functions	139
4.1	Features.....	139
4.2	List of Interrupt Sources.....	141
4.3	Interrupt Controller Control Registers	149
4.3.1	ICxx: EI Level Interrupt Control Register	149
4.3.2	IMRm (m = 0 to 13): EI Level Interrupt Mask Register	156
4.3.3	ISPR – In-Service Priority Register	164
4.3.4	PMR – Priority Mask Register	165
4.3.5	ISPC – In-Service Priority Clear Register.....	166
4.3.6	SCR – Selected Channel Hold Register.....	167
4.3.7	ICSR – Interrupt Controller Status Register	168
4.3.8	FNC – FE Level NMI Status Register.....	169
4.3.9	FIC – FE Level INT Status Register	170
4.3.10	INTCFGB – FE level Interrupt Switch Register	171
4.3.11	INTSTR0B – Error Interrupt Source Storage Register	172
4.3.12	INTSTC0B – Interrupt Request Flag Clearing Register.....	173
4.3.13	INTSTS0B – Interrupt Request Flag Setting Register	174
4.4	Interrupt Acknowledgment and Restoring.....	175
4.4.1	FE Level Non-Maskable Interrupt Caused by FENMI Interrupt Request.....	175
4.4.2	Restore from FE Level Non-Maskable Interrupt (FENMI)	177
4.4.3	FE Level Maskable Interrupt Caused by FEINT Interrupt Request	177
4.4.4	Restore from FE Level Maskable Interrupt (FEINT) Servicing	179
4.4.5	EI Level Maskable Interrupt Caused by EIINT Interrupt Request.....	180
4.4.6	Restore from EI Level Maskable Interrupt (EIINT)	182
4.5	Interrupt Operation.....	183
4.5.1	Mask Function of EI Level Maskable Interrupt (EIINT).....	183
4.5.2	Interrupt Priority Level Judgment.....	183
4.5.3	Priority Mask Function	189
4.5.4	Pending Interrupt Report Function	190
4.5.5	In-Service Priority Clear Function.....	190
4.6	Exception Handler Address Switching Function	191
4.7	Interrupt Response Times	191
Section 5	DMA Module	192
5.1	DMA in Overview	192
5.2	Definitions.....	196
5.3	Overview.....	197
5.3.1	Functions of the DMA Controller (DMAC)	197
5.3.2	Function of the DMA Trigger Factor Register (DTFR).....	197
5.3.3	Memory Map for DMA Access.....	199
5.3.4	Channel Priority	199
5.4	DMAC Function	200

5.4.1	Characteristics.....	200
5.4.2	Setting Registers	202
5.4.3	Availability of Writing to Control Registers.....	207
5.5	DMAC Control Registers	208
5.5.1	DTRC0: DMA Transfer Request Control Register 0.....	208
5.5.2	DTRSn (n = 0 to 7): DMA Transfer Request Select Register	209
5.5.3	DSAnL (n = 0 to 7): DMA Source Address Register L.....	210
5.5.4	DSAnH (n = 0 to 7): DMA Source Address Register H	211
5.5.5	DSCn (n = 0 to 7): DMA Source Chip Select Register	212
5.5.6	DNSAnL (n = 0 to 7): DMA Next Source Address Register L.....	213
5.5.7	DNSAnH (n = 0 to 7): DMA Next Source Address Register H	214
5.5.8	DNSCn (n = 0 to 7): DMA Next Source Chip Select Register	215
5.5.9	DDAnL (n = 0 to 7): DMA Destination Address Register L.....	216
5.5.10	DDAnH (n = 0 to 7): DMA Destination Address Register H.....	217
5.5.11	DDCn (n = 0 to 7): DMA Destination Chip Select Register	218
5.5.12	DNDAnL (n = 0 to 7): DMA Next Destination Address Register L.....	219
5.5.13	DNDAnH (n = 0 to 7): DMA Next Destination Address Register H.....	220
5.5.14	DNDcN (n = 0 to 7): DMA Next Destination Chip Select Register	221
5.5.15	DTCn (n = 0 to 7): DMA Transfer Count Register	222
5.5.16	DNTCn (n = 0 to 7): DMA Next Transfer Count Register	223
5.5.17	DTCCn (n = 0 to 7): DMA Transfer Count Compare Register.....	224
5.5.18	DTCTn (n = 0 to 7): DMA Transfer Control Register	225
5.5.19	DTSn (n = 0 to 7): DMA Transfer Status Register.....	227
5.6	DMAC Function Details	229
5.6.1	DMAC Transfer Setting Flow.....	229
5.6.2	DMAC Transfer Modes.....	230
5.6.3	DMAC Channel Priority Control.....	233
5.6.4	Conditions for Validity of DMA Transfer Requests	234
5.6.5	Next Address Function	235
5.6.6	Suspending/Resuming DMA Transfer	236
5.6.7	Error Responses.....	237
5.7	DTFR Functions.....	238
5.7.1	Features	238
5.8	DTFR Control Registers	239
5.8.1	DTFRn (n = 0 to 7): DMA Trigger Factor Register	239
5.8.2	DRQCLR: DMA Request Clear Register	240
5.8.3	DRQSTR: DMA Request Check Register	241
Section 6	Memory Modules	242
6.1	Features.....	243
6.1.1	Code Flash Memory	243
6.1.2	Data Flash Memory	244
6.1.3	On-Chip RAM	244
6.2	Programming Environment.....	245
6.3	Communications Methods	245

6.4	Handling of Pins.....	246
6.4.1	Power Supply	246
6.4.2	Pins.....	246
6.4.3	Reset Pin.....	246
6.4.4	FLMD0 Pin.....	247
6.4.5	Port Pins	247
6.5	Option-Setting Bytes.....	248
6.5.1	OPBT0 - Option Byte Verification Register.....	249
6.6	Product Identification	250
6.7	Setting the FLMD Pin.....	253
6.7.1	Registers	253
6.7.2	Setting the FLMDCNT Register.....	255
Section 7	Clock Generation	256
7.1	Overview of Clock Generation.....	257
7.2	Configuration	258
7.3	Selecting the Input Clock Signal.....	259
7.4	Clock Generating Circuit.....	260
7.5	Clock Output Function (CLKOUT)	261
7.5.1	Baud-Rate Generator for CLKOUT Function (BRGA).....	261
7.5.2	BRGA Registers for CLKOUT Function.....	263
7.6	Single-Pin Debugging Clock (LPDCLK).....	267
7.7	WDTA0 Count Clock (WDTCLKI).....	267
7.8	Clock Monitor A (CLMA _n) Function	268
7.8.1	Features of the Clock Monitors (CLMA _n ; n = 0, 1, 2).....	268
7.8.2	CLMA Enable and Start-Up Options.....	270
7.8.3	Functional Overview	270
7.8.4	Functional Description	271
7.8.5	Clock Monitor A Registers	277
Section 8	Reset Controller	282
8.1	Functional Overview	282
8.2	Functional Description	285
8.2.1	Reset Flags	285
8.2.2	Low-Voltage Indicator (LVI).....	286
8.2.3	External RESET	287
8.2.4	Watchdog Timer Reset.....	288
8.2.5	Software Reset.....	288
8.2.6	Clock Monitor Reset	289
8.2.7	Self-Diagnostic BIST Reset	290
8.2.8	Safety Guardian Reset	290
8.2.9	Reset Flag Evaluation	291
8.2.10	Protection for Registers of the Reset Controller	292
8.3	Registers.....	293

8.3.1	Overview of Reset Controller Registers	293
8.3.2	Details of Reset Controller Registers	294
8.3.3	Details of Software Reset Control Registers	298
8.3.4	Details of Protection Command Registers.....	299
8.4	Power-on Flag/Low Voltage Indicator (POF/LVI).....	300
8.4.1	Overview of the POF/LVI Function	300
8.4.2	Operation.....	301
8.4.3	Overview of POF/LVI Registers.....	304
8.4.4	Details of POF / LVI Control Registers	305
Section 9	Safety Functions	308
9.1	Peripheral Bus Access Error Detection	308
9.2	Memory Access Protection	308
9.2.1	Memory Access Protection.....	308
9.3	Registers Related to the Peripheral I/O Bus.....	309
9.3.1	Overview of Registers Related to the Peripheral I/O Bus.....	309
9.3.2	Details of Registers Related to the Peripheral I/O Bus.....	310
9.4	Overview of Self-Diagnostic BIST.....	315
9.4.1	Self-Diagnostic BIST Skip Function.....	315
9.4.2	Output of a Toggled Signal during Execution of Self-Diagnostic BIST.....	316
9.5	Self-Diagnostic BIST Related Registers	318
9.5.1	Overview of Registers Related to Self-Diagnostic BIST	318
9.5.2	Details of Registers Related to Self-Diagnostic BIST	319
9.5.3	Procedure for Setting the BSEQ0STCHBT Register.....	329
9.6	ECC Related Registers.....	330
9.6.1	Overview of ECC Related Registers	330
9.6.2	Details of ECC Related Registers	331
9.7	Self-Diagnosis Method for a Compare Unit	341
9.8	Resources Required for Initialization	342
9.8.1	On-chip RAM.....	342
9.8.2	Registers	342
Section 10	Safety Guardian (SGA)	346
10.1	SGA Features	346
10.2	SGA Functional Overview.....	349
10.3	Functional Description	352
10.3.1	SGA Operating States	352
10.3.2	SGA Configuration Overview.....	353
10.3.3	Operations for Error Output.....	354
10.3.4	Loop-Back Function.....	355
10.3.5	Pseudo Error Generation.....	356
10.3.6	Error Status	357
10.3.7	Writing to Protected Registers.....	358
10.4	Registers.....	359

10.4.1	Overview of SGA Registers	359
10.4.2	SGA Registers Details	360
Section 11	Data CRC Function A (DCRA)	378
11.1	DCRA Features	378
11.2	Functional Overview	379
11.3	Functional Description	381
11.4	Registers.....	382
11.4.1	DCRA Registers Overview	382
11.4.2	DCRA Registers Details	383
Section 12	Window Watchdog Timer A (WDTA)	386
12.1	WDTA Features	386
12.2	Functional Overview	387
12.3	Functional Description	388
12.3.1	WDTA after Reset Release	388
12.3.2	WDTA Trigger.....	389
12.3.3	Error Detection	390
12.3.4	75% Interrupt Output	392
12.3.5	Window Function	393
12.4	Registers.....	394
12.4.1	WDTA Registers Overview.....	394
12.4.2	WDTA Registers Details.....	395
Section 13	Timer Array Unit B (TAUB)	397
13.1	TAUB Features	397
13.2	Functional Overview	400
13.2.1	Terms	401
13.3	Functional Description	402
13.3.1	Functional List of Timer Operations.....	404
13.4	General Operating Procedures.....	405
13.5	Operation Modes	406
13.6	Concepts of Synchronous Channel Operation	407
13.6.1	Rules	407
13.6.2	Simultaneous Start and Stop of Synchronous Channel Counters.....	409
13.7	Simultaneous Rewrite.....	410
13.7.1	Overview.....	410
13.7.2	How to Control Simultaneous Rewrite.....	412
13.7.3	Other General Rules of Simultaneous Rewrite.....	414
13.7.4	Type of Simultaneous Rewrite.....	415
13.8	Channel Output Modes.....	421
13.8.1	General Procedures for Specifying a Channel Output Mode	423
13.8.2	Channel Output Modes Controlled Independently by TAUBn Signals	424

13.8.3	Channel Output Modes Controlled Synchronously by TAUBn Signals	425
13.9	Start Timing in Each Operating Modes.....	427
13.9.1	Interval Timer Mode, Judge Mode, Capture Mode, and Up/Down Count Mode.....	427
13.9.2	Event Mode	428
13.9.3	Other Operating Modes	428
13.10	TAUBnTTOUTm Output and INTTAUBnIm Generation when Counter Starts or Restarts (TAUBnMD0 bit)	429
13.11	TAUBnTTINm Edge Detection.....	431
13.12	Independent Channel Operation Functions	432
13.13	Independent Channel Interrupt Functions	432
13.13.1	Interval Timer Function.....	433
13.13.2	TAUBnTTINm Input Interval Timer Function	440
13.13.3	One-Pulse Output Function	446
13.14	Independent Channel Signal Measurement Functions.....	451
13.14.1	TAUBnTTINm Input Pulse Interval Measurement Function	452
13.14.2	TAUBnTTINm Input Signal Width Measurement Function	460
13.14.3	TAUBnTTINm Input Period Count Detection Function	468
13.14.4	TAUBnTTINm Input Pulse Interval Judgment Function.....	473
13.14.5	TAUBnTTINm Input Signal Width Judgment Function	478
13.15	Independent Channel Simultaneous Rewrite Functions.....	483
13.15.1	Simultaneous Rewrite Trigger Generation Function Type 1.....	484
13.16	Other Independent Channel Functions.....	490
13.16.1	External Event Count Function.....	491
13.16.2	Clock Divide Function.....	498
13.16.3	TAUBnTTINm Input Position Detection Function	505
13.17	Synchronous Channel Operation Functions	511
13.18	Synchronous PWM Signal Functions Triggered at Regular Intervals.....	512
13.18.1	PWM Output Function	513
13.18.2	Delay Pulse Output Function.....	524
13.18.3	AD Conversion Trigger Output Function Type 1	540
13.19	Synchronous PWM Signal Functions Triggered by an External Signal.....	542
13.19.1	One-Shot Pulse Output Function.....	543
13.20	Synchronous Triangle PWM Functions	556
13.20.1	Triangle PWM Output Function	557
13.20.2	Triangle PWM Output Function with Dead Time	568
13.20.3	AD Conversion Trigger Output Function Type 2	592
13.21	Registers.....	594
13.21.1	Overview of TAUBn Registers.....	594
13.21.2	Details of TAUBn Prescaler Registers.....	595
13.21.3	Details of TAUBn Control Registers	599
13.21.4	Details of TAUBn Output Registers	610
13.21.5	Details of TAUBn Channel Output Level Registers.....	614
13.21.6	Details of TAUBn Simultaneous Rewrite Registers.....	615

Section 14	Timer Array Unit J (TAUJ)	619
14.1	Features of TAUJ	619
14.2	Functional Overview	621
14.2.1	Terms	623
14.3	Functional Description	624
14.3.1	Timer Operation Functions	625
14.4	General Operating Procedure	626
14.5	Operating Modes	627
14.6	Concepts of Synchronous Channel Operation	628
14.6.1	Rules	628
14.6.2	Simultaneous Start and Stop of Synchronous Channel Counters	630
14.7	Simultaneous Rewrite	631
14.7.1	Overview	631
14.7.2	How to Control Simultaneous Rewrite	632
14.7.3	Other General Rules for Simultaneous Rewrite	633
14.7.4	Simultaneous Rewrite Procedure	634
14.8	Channel Output Modes	636
14.8.1	General Procedure for Specifying a Channel Output Mode	638
14.8.2	Channel Output Modes Controlled Independently by TAUJn Signals	639
14.8.3	Channel Output Modes Controlled Synchronously by TAUJn Signals	640
14.9	Start Timing of Operating Modes	641
14.9.1	Interval Timer Mode and Capture Mode	641
14.9.2	Other Operating Modes	642
14.10	TAUJnTTOUTm Output and INTTAUJnIm Generation When Counter Starts or Restarts	643
14.11	TAUJnTTINm Edge Detection	644
14.12	Independent Channel Operation Functions	645
14.12.1	Interval Timer Function	645
14.12.2	TAUJnTTINm Input Interval Timer Function	652
14.12.3	TAUJnTTINm Input Pulse Interval Measurement Function	658
14.12.4	TAUJnTTINm Input Signal Width Measurement Function	667
14.12.5	TAUJnTTINm Input Period Count Detection Function	675
14.12.6	TAUJnTTINm Input Position Detection Function	680
14.13	Synchronous Channel Functions	685
14.13.1	PWM Output Functions	686
14.14	Registers	697
14.14.1	Overview of TAUJn Registers	697
14.14.2	Details of TAUJn Prescaler Registers	698
14.14.3	Details of TAUJn Control Registers	702
14.14.4	Details of TAUJn Output Registers	713
14.14.5	Details of TAUJn Channel Output Level Registers	715
14.14.6	Details of TAUJn Reload Data Registers	716
Section 15	TSG2 (TSG20)	718

15.1	Functions of TSG2n.....	718
15.2	Functional Overview	720
15.3	Configuration	721
15.4	Registers.....	722
15.4.1	TSG2n Registers Overview	722
15.4.2	TSG2n Register Details.....	724
15.5	Basic Operation	773
15.5.1	Basic Operation of 16-Bit Counter.....	773
15.5.2	Functions of Compare Registers	775
15.5.3	Compare Register Rewrite Operation	778
15.5.4	List of Outputs in Each Mode	785
15.6	Match Interrupt.....	791
15.7	Flags.....	794
15.7.1	Up Count Flag (TSnCUF and TSnSUF)	795
15.7.2	Positive Phase and Inverse Phase Simultaneous Active State Detection Flag (TSnTBF0 to TSnTBF2)	797
15.7.3	Reload Request Flag (TSnRSF).....	798
15.7.4	Noise Detection Flag (TSnNDF).....	799
15.7.5	Pattern Order Detection Flag (TSnTSF).....	800
15.7.6	Pattern Error Detection Flag (TSnPEF).....	802
15.7.7	Pattern Reversal Detection Flag (TSnPRF)	803
15.7.8	TSG2nPTSI2 to TSG2nPTSI0 Pin Abnormal Toggle Detection Flag (TSnPTF)	804
15.7.9	TSnOPCI0 and TSnOPCI1 Signal Simultaneous Trigger Detection Flag (TSnTDF)	805
15.7.10	Pattern Phase Difference Detection Flag (TSnPPF)	806
15.7.11	Timer Output Pattern Flag (TSnOPF2 to TSnOPF0).....	807
15.7.12	Pattern Switch Detection Signal (TSnPTE)	808
15.8	Interrupt Skipping Function.....	810
15.8.1	Operation of Interrupt Skipping Function.....	811
15.8.2	Example of Operation when Peak Interrupt is Generated (in PWM Mode)	815
15.9	A/D Conversion Trigger Function	816
15.9.1	Operation of A/D Conversion Trigger	817
15.10	Error/Warning Interrupt.....	823
15.10.1	Error Interrupt Function	823
15.10.2	Warning Interrupt Function.....	826
15.11	Operating Modes	827
15.11.1	PWM Mode.....	828
15.11.2	HT-PWM Mode (High accuracy Triangular - Pulse Width Modulation Mode)	839
15.11.3	SP-PWM Mode (Shifted-pulse - Pulse Width Modulation Mode)	861
15.11.4	120-DC Mode	873
15.11.5	Software Output Control Function	907
Section 16	TPBA.....	909
16.1	Functions of TPBA.....	909
16.2	Functional Overview	910

16.3	Configuration	911
16.4	Registers.....	912
16.4.1	TPBAn Registers Overview	912
16.4.2	TPBAn Registers Details	913
16.5	Basic Operation	926
16.5.1	Basic Operation of Counter	926
16.5.2	Compare Register Rewrite Operation	927
16.5.3	Duty Rewrite Operation	930
16.5.4	Basic Operation Example	933
Section 17	OS Timer (OSTM).....	938
17.1	OSTM Features	938
17.2	Functional Overview	940
17.3	Functional Description	941
17.3.1	Clock Signal to Drive Counting.....	941
17.3.2	Output Modes	943
17.3.3	Interrupt Request Generation	944
17.3.4	Starting and Stopping the Timer.....	945
17.3.5	Interval Timer Mode.....	946
17.3.6	Free-Running Comparison Mode	950
17.4	Registers.....	953
17.4.1	OS Timer Registers Overview	953
17.4.2	OS Timer Registers in Detail	954
Section 18	Encoder Timer (ENCA)	964
18.1	ENCA Features.....	964
18.2	Functional Overview	966
18.2.1	Block Diagram	967
18.3	ENCA Control Registers	968
18.4	Functional Description	983
18.4.1	Timer Counter Operation.....	983
18.4.2	Up/Down Control of Timer Counter	987
18.4.3	Control of Timer Counter Clearing.....	991
18.4.4	Detailed Description of the ENCAAnCCR0 Register	997
18.4.5	Detailed Description of the ENCAAnCCR1 Register	999
18.4.6	Timer Counter Operation Start/Stop.....	1003
18.5	Setting Sequences.....	1004
18.5.1	Encoder Timer Setting Procedure	1004
18.6	Timing Charts for Encoder Operations	1007
Section 19	Timer Option Module (TAPA).....	1013
19.1	Features of the Timer Option Module	1013
19.2	Functional Overview	1021

19.2.1	Block Diagram	1021
19.2.2	Peak and Valley of Timer Counter, and Peak and Valley Interrupts	1022
19.3	Registers.....	1023
19.3.1	Registers Overview	1023
19.3.2	Registers Details	1024
19.4	Basic Functions	1030
19.4.1	Hi-Z Control Functions.....	1030
19.4.2	Asynchronous Hi-Z Control for Pin Inputs	1031
19.4.3	Selection of INT Signal Output	1037
19.4.4	Selecting a Trigger to Start Conversion by the A/D Converter	1041
Section 20	CAN Controller (FCN)	1046
20.1	FCN Features	1046
20.2	Features	1048
20.2.1	Overview of Functions	1049
20.2.2	Configuration	1050
20.3	Internal Registers of FCN	1051
20.3.1	CAN Controller Configuration	1051
20.3.2	Overview of CAN Controller Registers	1052
20.3.3	Register Bit Configuration.....	1054
20.4	Bit Set/Clear Functions	1059
20.5	Control Registers	1061
20.5.1	FCN Global Registers.....	1061
20.5.2	FCN Module Registers	1069
20.5.3	FCN Message Buffer Registers.....	1089
20.6	CAN Controller Initialization.....	1099
20.6.1	Initialization of FCN Module.....	1099
20.6.2	Redefinition of Message Buffer	1099
20.6.3	Transition from Initialization Mode to Operating Mode	1101
20.7	Reception of Message	1102
20.7.1	Message Reception.....	1102
20.7.2	Receive Data Read	1103
20.7.3	Receive History List Function	1104
20.7.4	Mask Function	1106
20.7.5	Multi Buffer Receive Block Function.....	1107
20.7.6	Remote Frame Reception	1108
20.8	Transmission of Message.....	1110
20.8.1	Message Transmission.....	1110
20.8.2	Transmit History List Function	1112
20.8.3	Automatic Block Transmission (ABT).....	1114
20.8.4	Transmission Abort Process.....	1116
20.8.5	Remote Frame Transmission	1117
20.9	Power Save Modes.....	1118
20.9.1	FCN Sleep Mode	1118

20.9.2	FCN Stop Mode.....	1121
20.9.3	Example of Using Power Save Modes	1122
20.10	Interrupt Function.....	1123
20.11	Diagnosis Functions and Special Operating Modes	1124
20.11.1	Receive-only Mode.....	1124
20.11.2	Single-shot Mode.....	1125
20.11.3	Self-test Mode	1126
20.11.4	Receive/Transmit Operations in Each Operating Mode	1127
20.12	Time Stamp Function.....	1128
20.12.1	Time Stamp Function	1128
20.13	Baud Rate Settings.....	1130
20.13.1	Baud Rate Setting Conditions	1130
20.13.2	Typical Examples of Baud Rate Settings	1133
20.14	Operation of the CAN Controller.....	1137
20.14.1	Initialization.....	1137
20.14.2	Message Transmission.....	1143
20.14.3	Message Reception.....	1158
20.14.4	Power Save Modes	1163
Section 21	Clocked Serial Interface G (CSIG).....	1170
21.1	CSIG Features.....	1170
21.2	Functional Overview	1172
21.3	Functional Description	1174
21.3.1	Master/Slave Mode.....	1174
21.3.2	Master/Slave Connections.....	1175
21.3.3	Selection of Serial Communications Clock.....	1176
21.3.4	Data Transfer Modes.....	1177
21.3.5	Data length Selection	1178
21.3.6	Serial Data Direction Selection.....	1180
21.3.7	Communication in Slave Mode.....	1181
21.3.8	CSIG Interrupts.....	1182
21.3.9	Handshake Function.....	1185
21.3.10	Loop-Back Mode	1187
21.3.11	Error Detection	1188
21.4	CSIG Control Registers	1192
21.5	Operating Procedure Example	1207
Section 22	Synchronous/Asynchronous Serial Interface H (UARTH).....	1209
22.1	UARTHn Features	1209
22.2	Features.....	1211
22.3	Configuration	1212
22.4	UARTHn Registers	1213
22.5	Interrupt Request Signals	1242
22.5.1	Transmission Interrupt Request URTHnTIT	1242

22.5.2	Reception Interrupt Request URTHnTIR.....	1243
22.5.3	Status Interrupt Request URTHnTIS.....	1243
22.6	Operation.....	1244
22.6.1	Data Formats.....	1244
22.6.2	Clock Synchronous Mode.....	1247
22.6.3	Handshake Mode.....	1248
22.6.4	Consecutive Two-Frame Transfer Mode.....	1250
22.6.5	Extension bit Detection/ID Compare-Match Detection.....	1252
22.6.6	BF Transmission/Reception Format.....	1254
22.6.7	BF Transmission.....	1256
22.6.8	BF Reception.....	1257
22.6.9	Transmission Data Consistency Check.....	1259
22.6.10	UARTHn Transmission.....	1260
22.6.11	Continuous Transmission Procedure.....	1261
22.6.12	UARTHn reception.....	1263
22.6.13	Reception Errors.....	1265
22.6.14	Parity Types and Operations.....	1266
22.6.15	Digital Receive Data Noise Filter.....	1267
22.7	Baud-Rate Generator.....	1268
22.8	Detecting the Baud Rate in LIN Communications as a Slave.....	1269
Section 23	A/D Converter.....	1270
23.1	ADCA Features.....	1270
23.2	Functional Overview.....	1273
23.3	Functional Description.....	1275
23.3.1	Basic Operation.....	1277
23.3.2	Clock Usage.....	1278
23.3.3	Channel and Channel Group.....	1279
23.3.4	A/D Conversion Modes.....	1281
23.3.5	Starting A/D Conversion (Start Triggers).....	1285
23.3.6	Stopping A/D Conversion (Stop Trigger).....	1287
23.3.7	Resolution, Sampling Time and Conversion Time.....	1288
23.3.8	Interrupt Generation.....	1290
23.3.9	Storage of A/D Conversion Results.....	1291
23.3.10	Result Check Functions.....	1294
23.3.11	Self-Diagnosis Functions.....	1296
23.3.12	Channel Sample and Hold Function.....	1305
23.3.13	Discharge Function.....	1310
23.3.14	Buffer Amplifier Function.....	1311
23.3.15	Stabilization Control.....	1311
23.4	Registers.....	1312
23.4.1	ADCAn Registers Overview.....	1312
23.4.2	Control Registers.....	1314
23.4.3	Conversion Status Registers.....	1324
23.4.4	Software Trigger Registers.....	1328

23.4.5	A/D Conversion Result Registers	1329
23.4.6	A/D Conversion Result Upper/Lower Limit Comparison Registers	1337
23.4.7	Diagnosis Function Control Registers	1341
23.4.8	Channel Sample and Hold Function Setting Register	1344
23.5	Usage Notes	1345
23.5.1	Range of Channel Input Voltage	1345
23.5.2	Stopping Conversion Operation	1345
23.5.3	Restrictions on Using Channel Sample and Hold Function	1345
23.5.4	Application Design Notes	1345
23.6	How to Read A/D Converter Characteristics Table	1350
Section 24	Peripheral Interconnection (PIC).....	1357
24.1	Features of Peripheral Interconnection.....	1357
24.2	Functional Overview	1358
24.3	Peripheral Interconnection Registers.....	1359
24.3.1	Start of PIC Function	1361
24.4	Connection Functions	1362
24.4.1	Simultaneous Start Trigger Function	1362
24.4.2	ADC Trigger Selection Function	1369
24.4.3	High Accuracy Triangle Wave PWM Output Function with Dead Time.....	1377
24.4.4	Trigger and Pulse Width Measurement Function	1408
24.4.5	Encoder Capture Trigger Selection Function	1422
24.4.6	Two-Phase Encoder Control Function (Control Method 1).....	1432
24.4.7	Two-Phase Encoder Control Function (Control Method 2).....	1444
24.4.8	Three-Phase Encoder Control Function	1455
24.4.9	CAN Time Stamp Function.....	1464
24.4.10	TSG20 and TAUB0 Dead-Time Reduction Function.....	1466
24.4.11	TAUB Input Selection	1478
Section 25	On-chip Debugging Unit (OCD)	1483
25.1	Functional Overview	1483
25.2	Connection with the On-Chip Debugging Emulator	1486
25.3	Notes on On-Chip Debugging.....	1489
Section 26	Power Supply Configuration	1493
Section 27	Electrical Characteristics.....	1494
27.1	Absolute Maximum Ratings	1494
27.2	Capacity.....	1495
27.3	Operating Conditions	1495
27.4	Characteristics of Oscillation Circuit	1496
27.4.1	Characteristics of Oscillation Circuit	1496
27.4.2	Characteristics of Internal Oscillation Circuit	1497
27.5	DC Characteristics.....	1498

27.6	AC Characteristics	1502
27.6.1	Measurement Conditions.....	1502
27.6.2	Clock Timing (CLKOUT).....	1503
27.6.3	Timing in Turning the Power Supply On and Off	1504
27.6.4	Regulator Characteristics	1506
27.6.5	Reset Timing	1507
27.6.6	Interrupt Timing	1508
27.6.7	ESOn Timing	1509
27.6.8	ADCA0TRGn Timing	1510
27.6.9	Timer Timing.....	1511
27.6.10	CSIGn Timing.....	1512
27.6.11	UARTHn Timing	1518
27.6.12	CAN Timing	1525
27.6.13	Nexus Interface Timing.....	1526
27.6.14	LPD Interface.....	1527
27.6.15	A/D Converter Characteristics	1528
27.6.16	POF/LVI Characteristics	1533
27.6.17	Flash Memory Programming Characteristics	1535
27.6.18	FLMD0 Pulse Timing Characteristics	1536
27.6.19	Self-Diagnosis BIST Execution Time.....	1538

Section 1 Introduction

V850E2/PG4-L(μ PD70F4154, μ PD70F4155) is a product in the V850 Series of single-chip microcomputers from Renesas Electronics. This section gives an overview of the V850E2/PG4-L.

1.1 Overview

This 32-bit single-chip microcomputer is a best fit for applying high-speed calculation in the precise control of motors and is equipped with V850E2M CPUs from the V850 Series, ROM, RAM, a DMA controller, and various peripheral modules including several timers such as a PWM timer, serial interfaces such as CAN, and an A/D converter.

(1) V850E2M CPU Equipped

This product is equipped with two V850E2M CPUs: one is used as the master CPU and the other is used as a checker CPU, which monitors the master CPU. The two CPUs operate in lockstep.

The V850E2M CPU supports a RISC-type instruction set, and instruction execution speeds are dramatically improved by the execution of one basic instruction per clock cycle and an optimized 7-stage pipeline. Furthermore, support for digital servo-control is provided by a 32-bit hardware multiplier for the multiplication instruction, a saturation sum-of-products instruction, bit-manipulation instructions, and so on.

In addition, the 2-byte length for instructions, instructions corresponding to high-level languages, and other measures improve the efficiency of object code from the C compiler, leading to smaller executable programs. The product's quick interrupt response, including processing by the on-chip interrupt controller, makes it suitable for advanced realtime control fields.

(2) Flash Memory and Data Flash Memory Equipped

This product has a flash memory that provides high-speed access, allowing reprogramming of the product's memory while it is mounted on an application system. This shortens system development periods and dramatically improves systems for maintenance after the product is shipped.

Moreover, the product is equipped with 16 Kbytes of data-flash memory for use, in typical examples, as a substitute for EEPROM.

(3) Products for the Development Environment

The following components of integrated development environments are ready for use with this product: optimized C compiler, debugger, in-circuit emulator, system performance analyzer, realtime OS, etc.

The Nexus function allows realtime debugging.

(4) Protection Function

The following functions are available to guarantee highly reliable CPU operations: memory protection, peripheral device protection, system register protection, and timing supervision.

1.2 Characteristics

CPU core	V850E2M: 2 units (with lockstep operation) One CPU core for normal operation (master CPU), and one CPU core to monitor the first for normal operation (checker CPU)
Number of instructions	Normal instructions: 98 Debug instructions: 3
Minimum instruction execution times	20.83, 15.625, 12.5 ns (for internal operation at 48, 64, and 80 MHz)
General purpose registers	32 bits × 32
Instruction set	V850E2v3 Signed multiplication (32 bits × 32 bits → 64 bits): 1 or 2 CPU clock cycles Saturation calculation instruction (with overflow/underflow detection) 32-bit arithmetic/logic shift instruction: 1 CPU clock cycle Bit-manipulation instructions Loading/storing instructions in long/short formats Signed load instruction
Memory space	512-Mbyte address space (common for programs and data)
On-chip memory	Flash memory: 384 Kbytes Data flash: 16 Kbytes RAM: 24 Kbytes
Interrupts/exceptions	All interrupts: 131 sources External interrupts: 10 (max.) Internal interrupts: 110 sources (max.) Software interrupts: 11 sources Exceptions: 21 sources 16 levels available for use in prioritization

DMA controller	<p>8-channel configuration</p> <p>Transfer unit: 8, 16, 32, or 128 bits</p> <p>Maximum number of transfers: $32768(2^{15})$</p> <p>Transfer type: 2-cycle transfer (dual-address transfer)</p> <p>Transfer mode: single transfer/single step transfer</p> <p>Target to transfer: peripheral I/O \longleftrightarrow peripheral I/O, RAM \longleftrightarrow peripheral I/O, RAM \longleftrightarrow RAM, peripheral I/O \leftarrow flash, RAM \leftarrow flash, peripheral I/O \leftarrow D- flash, RAM \leftarrow D- flash</p> <p>Transfer requests: peripheral I/O and software</p> <p>Next address setting function</p>
I/O	<p>I/O port: 46</p> <p>Software pull-up function: 46</p>
Timer function	<p>Timer array unit B (TAUB): 16 channels \times 1 unit</p> <p>Timer unit including 16 independent 16-bit counter channels, and a dedicated prescaler</p> <p>Timer array unit J (TAUJ): 4 channels \times 1 unit</p> <p>Timer unit including 4 independent 32-bit counter channels, and a dedicated prescaler</p> <p>TSG2: 1 unit</p> <p>Timer unit suitable for motor control</p> <p>Timer pattern buffer (TPBA): 1 unit</p> <p>Timer unit suitable for duty-cycle and period settings</p> <p>Encoder timer (ENCA): 1 unit</p> <p>Timer unit suitable for 2-phase encoder control</p> <p>OS timer (OST): 2 units</p> <p>For use by the OS: 32-bit free running interval timer with timer output function</p> <p>Window watchdog timer (WDTA0)</p> <ul style="list-style-type: none"> – Window watchdog function: window and 75% interrupt – Reset on error detection, or generation of FENMI/FEINT
Serial interface (SIO)	<p>Synchronous/asynchronous serial interface H (UARTH): 2 channels</p> <ul style="list-style-type: none"> – Switching between synchronous and asynchronous settings – Available for use as a slave in LIN communications <p>Clocked serial interface (CSIG): 2 channels</p> <p>CAN interface: 2 channels (32 msg)</p>
A/D converter	<p>A/D converter with 12-bit resolution:</p> <p>18 channels (6 S/H channels + 12 other channels) \times 1 unit</p>

Internal connecting function	Peripheral Interconnection (PIC): 1 unit Interlocking operations (simultaneous starting and so on) are obtainable through connection to timers and peripheral I/O
Forcibly stopping output	Timer option unit (TAPA): 2 units Unit for controlling the Hi-Z state of pins for the TAUB and TSG2 timer
Generating clock signals	Frequency multiplication by PLL clock synthesizer Clock output functions
Baud rate generator (BRG)	Allows setting of the operating clock frequency to suit the conditions of use
Data CRC	Data CRC (cyclic redundancy checking) can be used to verify or generate data streams protected by CRC with different widths in bits for various lengths
Safety functions	Flash memory ECC error detection RAM ECC error detection Oscillation stop detection Build In Self Test (BIST) functions Safety guardian function (SGA)
Standby function	HALT mode
POF/LVI function	Facility for detecting abnormal power-supply voltages
On-chip debugger	Nexus: 1 channel LPD(single-pin debugging): 1 channel
Packages	100-pin plastic LQFP (0.5 mm pitch) (14 × 14)

1.3 List of Functions

Series Name		V850E2/PG4-L		
Product		μPD70F4154	μPD70F4155	
On-chip memory	Code flash	384 Kbytes	384 Kbytes	
	Data flash	16 Kbytes	16 Kbytes	
	RAM	24 Kbytes	24 Kbytes	
Operating frequency	Ta: 125°C (max.)	80 MHz (max.)	80 MHz (max.)	
Oscillation frequency		16 MHz	8 MHz	
Baud-rate generator (BRG)		1 unit	1 unit	
DMA		8 channels	8 channels	
Timers	Unit functions	TSG2	1 unit	1 unit
		TAUB	1 unit	1 unit
		TAUJ	1 unit	1 unit
		OST	2 units	2 units
		WDTA	1 unit	1 unit
		ENCA	1 unit	1 unit
		TPBA	1 unit	1 unit
		TAPA	2 units	2 units
		PIC	1 unit	1 unit
Serial interfaces	Synchronous/asynchronous UART	2 channels	2 channels	
	CSIG	2 channels	2 channels	
	CAN (number of messages)	2 channels (32 msg)	2 channels (32 msg)	
A/D converter	Resolution	12 bits	12 bits	
	Input channels	18 channels (6 S/H + 12 other)	18 channels (6 S/H + 12 other)	
Interrupts	External	10	10	
	Internal	110	110	
	Software	11	11	
I/O ports	Input/output	46	46	
Nexus		1 channel	1 channel	
LPD (single-pin debugging)		1 channel	1 channel	
Data CRC (DCRA)		2 channels	2 channels	
Safety guardian (SGA)		1 channel	1 channel	
Power-on flag		Included	Included	
Low voltage detection		Included	Included	
Self-diagnosis BIST-SKIP function		Included	Included	

Series Name		V850E2/PG4-L	
Product		μ PD70F4154	μ PD70F4155
Power-supply voltages	For internal use	3.0 V to 5.5 V	3.0 V to 5.5 V
		Internal regulator	Included
	For interfaces	3.0 V to 5.5 V	3.0 V to 5.5 V
	For A/D converter	4.2 V - 5.5 V	4.2 V - 5.5 V
	For reprogramming flash memory	3.0 V to 5.5 V	3.0 V to 5.5 V
Package		100 pins LQFP 0.5-mm pitch 14 x 14 mm \square 1.4-mm thick	100 pins LQFP 0.5-mm pitch 14 x 14 mm \square 1.4-mm thick

1.4 Field of Application

- Electrical systems (motor control systems, electric automobiles, etc.)

1.5 Information for Ordering

Product Name	Package	On-Chip ROM	Quality Standard	Operating Ambient Temperature (T _A)	External Oscillator	Maximum Operating Frequency
μPD70F4154GC(A2)-UEU-AX	100 pin (0.5-mm pitch) (14 × 14) 1.4-mm thick	Flash memory	Special	−40 to +125°C	16 MHz	80 MHz
μPD70F4155GC(A2)-UEU-AX					8 MHz	80 MHz

Note The products listed above are all lead free.

For details on the quality standards and fields of application, refer to the following document issued by Renesas: NEC Semiconductor Device Quality Standards (document reference number: C11531J). The former company name remains in the document but it is still a valid Renesas document.

1.6 Pin Connection Diagram (Top View)

μPD70F4154, μPD70F4155

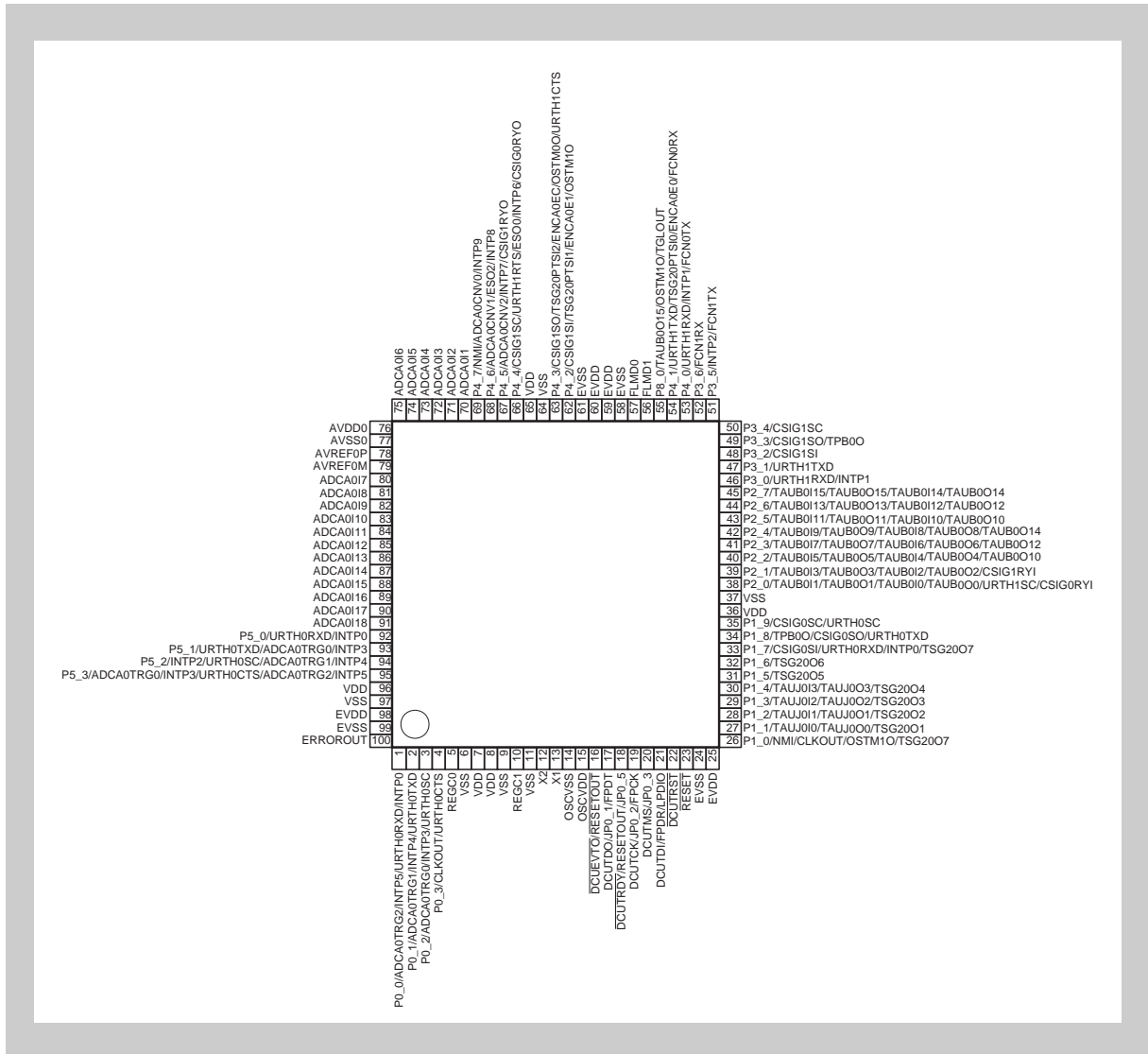

Table 1-1 List of Pin Numbers and Names (1/3)

Pin Number	Pin Name	I/O
1	P0_0/ADCA0TRG2/INTP5/URTH0RXD/INTP0	I/O
2	P0_1/ADCA0TRG1/INTP4/URTH0TXD	I/O
3	P0_2/ADCA0TRG0/INTP3/URTH0SC	I/O
4	P0_3/CLKOUT/URTH0CTS	I/O
5	REGC0	V
6	VSS	G
7	VDD	V
8	VDD	V
9	VSS	G
10	REGC1	V
11	VSS	G
12	X2	O
13	X1	I
14	OSCVSS	G
15	OSCVDD	V
16	$\overline{\text{DCUEVTO}}/\overline{\text{RESETOUT}}$	O
17	DCUTDO/JP0_1/FPDT	I/O
18	$\overline{\text{DCUTRDY}}/\overline{\text{RESETOUT}}/\text{JP0}_5$	I/O
19	DCUTCK/JP0_2/FPCK	I/O
20	DCUTMS/JP0_3	I/O
21	DCUTDI/FPDR/LPDIO	I/O
22	$\overline{\text{DCUTRST}}$	I
23	$\overline{\text{RESET}}$	I
24	EVSS	G
25	EVDD	V
26	P1_0/NMI/CLKOUT/OSTM1O/TSG2007	I/O
27	P1_1/TAUJ0I0/TAUJ0O0/TSG2001	I/O
28	P1_2/TAUJ0I1/TAUJ0O1/TSG2002	I/O
29	P1_3/TAUJ0I2/TAUJ0O2/TSG2003	I/O
30	P1_4/TAUJ0I3/TAUJ0O3/TSG2004	I/O
31	P1_5/TSG2005	I/O
32	P1_6/TSG2006	I/O
33	P1_7/CSIG0SI/URTH0RXD/INTP0/TSG2007	I/O
34	P1_8/TPB0O/CSIG0SO/URTH0TXD	I/O
35	P1_9/CSIG0SC/URTH0SC	I/O
36	VDD	V
37	VSS	G
38	P2_0/TAUB0I1/TAUB0O1/TAUB0I0/TAUB0O0/URTH1SC/CSIG0RYI	I/O

Table 1-1 List of Pin Numbers and Names (2/3)

Pin Number	Pin Name	I/O
39	P2_1/TAUB0I3/TAUB0O3/TAUB0I2/TAUB0O2/CSIG1RYI	I/O
40	P2_2/TAUB0I5/TAUB0O5/TAUB0I4/TAUB0O4/TAUB0O10	I/O
41	P2_3/TAUB0I7/TAUB0O7/TAUB0I6/TAUB0O6/TAUB0O12	I/O
42	P2_4/TAUB0I9/TAUB0O9/TAUB0I8/TAUB0O8/TAUB0O14	I/O
43	P2_5/TAUB0I11/TAUB0O11/TAUB0I10/TAUB0O10	I/O
44	P2_6/TAUB0I13/TAUB0O13/TAUB0I12/TAUB0O12	I/O
45	P2_7/TAUB0I15/TAUB0O15/TAUB0I14/TAUB0O14	I/O
46	P3_0/URTH1RXD/INTP1	I/O
47	P3_1/URTH1TXD	I/O
48	P3_2/CSIG1SI	I/O
49	P3_3/CSIG1SO/TPB0O	I/O
50	P3_4/CSIG1SC	I/O
51	P3_5/INTP2/FCN1TX	I/O
52	P3_6/FCN1RX	I/O
53	P4_0/URTH1RXD/INTP1/FCN0TX	I/O
54	P4_1/URTH1TXD/TSG20PTSI0/ENCA0E0/FCN0RX	I/O
55	P8_0/TAUB0O15/OSTM1O/TGLOUT	I/O
56	FLMD1	I
57	FLMD0	I
58	EVSS	G
59	EVDD	V
60	EVDD	V
61	EVSS	G
62	P4_2/CSIG1SI/TSG20PTSI1/ENCA0E1/OSTM1O	I/O
63	P4_3/CSIG1SO/TSG20PTSI2/ENCA0EC/OSTM0O/URTH1CTS	I/O
64	VSS	G
65	VDD	V
66	P4_4/CSIG1SC/URTH1RTS/ESO0/INTP6/CSIG0RYO	I/O
67	P4_5/ADCA0CNV2/INTP7/CSIG1RYO	I/O
68	P4_6/ADCA0CNV1/ESO2/INTP8	I/O
69	P4_7/NMI/ADCA0CNV0/INTP9	I/O
70	ADCA0I1	I
71	ADCA0I2	I
72	ADCA0I3	I
73	ADCA0I4	I
74	ADCA0I5	I
75	ADCA0I6	I
76	AVDD0	V

Table 1-1 List of Pin Numbers and Names (3/3)

Pin Number	Pin Name	I/O
77	AVSS0	G
78	AVREF0P	I
79	AVREF0M	I
80	ADCA0I7	I
81	ADCA0I8	I
82	ADCA0I9	I
83	ADCA0I10	I
84	ADCA0I11	I
85	ADCA0I12	I
86	ADCA0I13	I
87	ADCA0I14	I
88	ADCA0I15	I
89	ADCA0I16	I
90	ADCA0I17	I
91	ADCA0I18	I
92	P5_0/URTH0RXD/INTP0	I/O
93	P5_1/URTH0TXD/ADCA0TRG0/INTP3	I/O
94	P5_2/INTP2/URTH0SC/ADCA0TRG1/INTP4	I/O
95	P5_3/ADCA0TRG0/INTP3/URTH0CTS/ADCA0TRG2/INTP5	I/O
96	VDD	V
97	VSS	G
98	EVDD	V
99	EVSS	G
100	ERROROUT	O

Pin Name	
ADCA0I1 - ADCA0I18	: Analog input
ADCA0TRG0 - ADCA0TRG2	: ADC trigger input
ADCA0CNV0 - ADCA0CNV2	: ADC status output
AVDD0	: Analog power supply
AVREF0P	: Analog reference voltage (positive)
AVREF0M	: Analog reference voltage (minimal)
AVSS0	: Analog ground
CLKOUT	: Clock output
CPUPLLVDD	: CPU PLL power supply
CPUPLLVSS	: CPU PLL ground
CSIG0SC, CSIG1SC	: Serial clock
CSIG0SI, CSIG1SI	: Serial input
CSIG0SO, CSIG1SO	: Serial output
CSIG0RYI, CSIG1RYI	: Serial ready/busy input signal
CSIG0RYO, CSIG1RYO	: Serial ready/busy output signal
DCUEVTO	: Nexus event output
DCUTCK	: Nexus input clock
DCUTDI	: Nexus input
DCUTDO	: Nexus output
DCUTMS	: Nexus mode select
DCUTRDY	: Nexus ready output
DCUTRST	: Nexus reset input
ENCA0E0, ENCA0E1	: Timer encoder count pulse input
ENCA0EC	: Timer encoder clear input
ERROROUT	: Error output signal
ESO0, ESO2	: Timer output compulsion stop input
EVDD	: I/O/CODE Flash/DATA Flash Memory power supply
EVSS	: I/O/CODE Flash/DATA Flash Memory ground
FCN0RX, FCN1RX	: Receive data for controller area network
FCN0TX, FCN1TX	: Transmit data for controller area network
FLMD0	: Flash programming mode
FLMD1	: Flash programming mode
FPDR	: Receive or Transmit Data for Flash writing in (UART) or Serial Input for Flash writing in (CSI)
FPCK	: Serial Clock for Flash writing in (CSI)
FPDT	: Serial Output for Flash writing in (CSI)
INTP0 - INTP9	: External interrupt input

JP0_1 - JP0_3, JP0_5	: PortJP0 (JTAG)
LPDIO	: 1pin debug Input/Output
NMI	: Non-maskable interrupt input
OSTM00, OSTM10	: Operation system timer output
OSCVDD	: OSC power supply
OSCVSS	: OSC ground
P0_0 - P0_3	: Port 0
P1_0 - P1_9	: Port 1
P2_0 - P2_7	: Port 2
P3_0 - P3_6	: Port 3
P4_0 - P4_7	: Port 4
P5_0 - P5_3	: Port 5
P8_0	: Port 8
REGC0, REGC1	: Capacitor for internal voltage regulator
RESET	: Reset input
RESETOUT, RESETOUT	: Reset output
TAUB0I0-TAUB0I15, TAUJ0I0-TAUJ0I3	: Timer input
TAUB0O0- TAUB0O15, TAUJ0O0-TAUJ0O3	: Timer output
TGLOUT	: Toggle signal output
TPB00	: Timer pattern buffer pulse output
TSG2001-TSG2007	: Timer pulse output
TSG20PTS10- TSG20PTS12	: Timer pattern input
URTH0RXD, URTH1RXD	: Receive data
URTH0TXD, URTH1TXD	: Transmit data
URTH0SC, URTH1SC	: UART input clock
URTH0CTS, URTH1CTS	: UART clear to send (input)
URTH1RTS	: UART request to send (output)
VDD	: Power supply for internal voltage regulator
VSS	: Ground for internal voltage regulator
X1, X2	: Crystal

1.7 Configuration of Functional Blocks

1.7.1 Internal Block Diagram

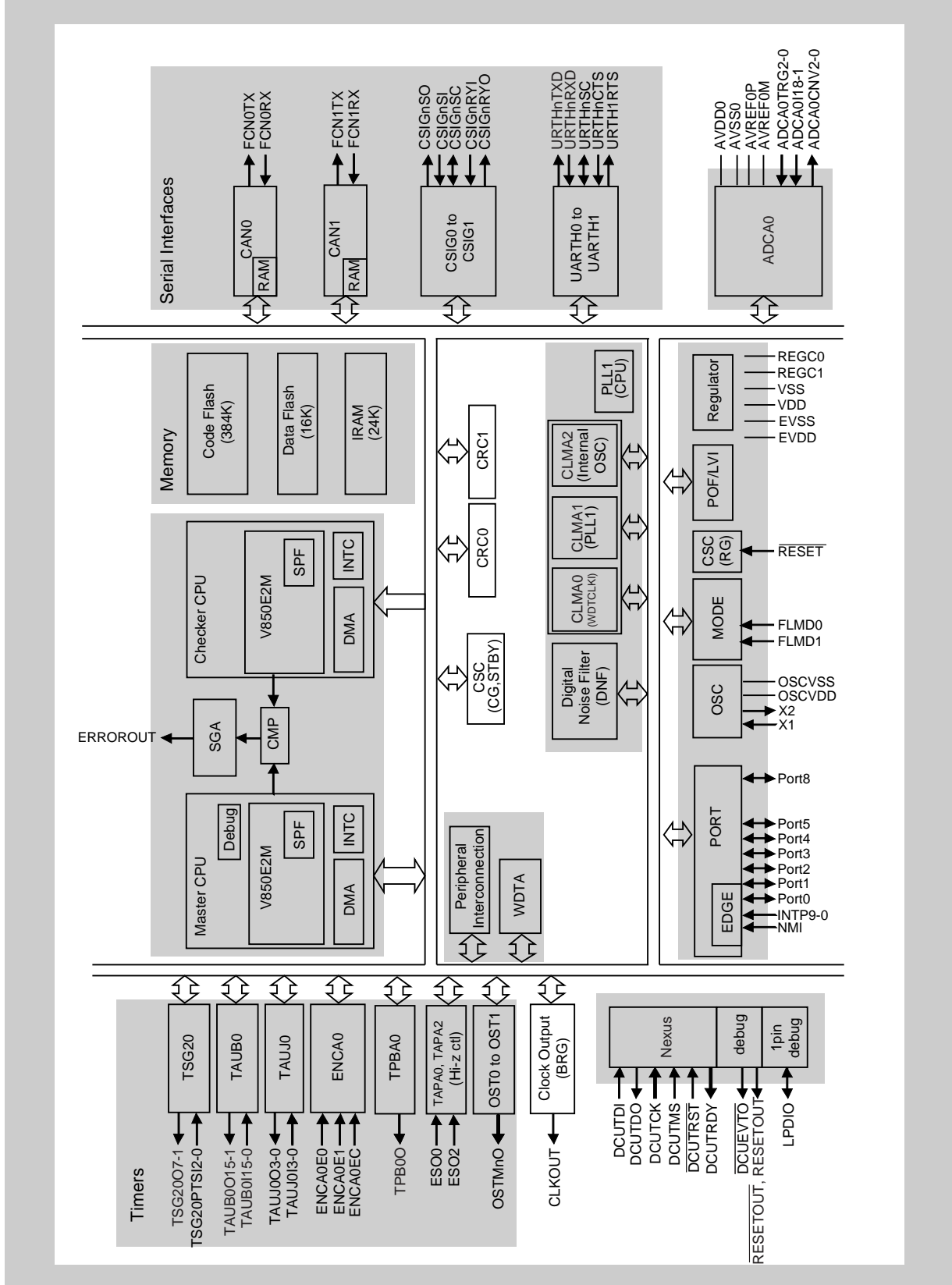

1.7.2 Internal Units

(1) CPU

Processing of almost all instructions is executed in a single clock cycle under 7-stage pipeline control.

The CPU includes a multiplier (16 bits × 16 bits → 32 bits, or 32 bits × 32 bits → 64 bits) and barrel shifter (32 bits) to speed up complicated instruction processing.

(2) DMA Controller (DMAC)

These controllers transfer data between memory and peripheral I/O. Each module has two transfer modes: single transfer and single step transfer (DMA).

(3) ROM

The ROM consists of code flash memory and data flash memory. Memory capacity is given in the following table.

The CPU is able to access ROM in a single clock cycle when fetching instructions.

Table 1-2 Memory Capacity and Addresses of Code Flash and Data Flash

Product Name	Data Flash Memory Capacity	Address Range
	Code Flash Memory Capacity	
μPD70F4154	16 Kbytes	0200_0000 _H to 0200_3FFF _H
μPD70F4155	384 Kbytes	0000_0000 _H to 0005_FFFF _H

(4) RAM

Mappings of RAM are listed below.

Table 1-3 RAM Capacities and Address Ranges

Product Name	RAM Capacity	Address Range
μPD70F4154 μPD70F4155	24 Kbytes	FEDF_A000 _H to FEDF_FFFF _H

(5) Interrupt Controller (INTC)

This module handles peripheral I/O and external hardware interrupt requests (INTP9-0). These interrupts can be prioritized at 16 levels to control multiple forms of handling for the interrupt sources.

(6) Clock Generation

An external oscillator is connected to the X1 and X2 pins as an input clock. The signal from the oscillator is input to the PLL1 synthesizer for frequency multiplying (the multiple is switched by optional bytes). The PLL1 output is supplied as the internal system clock and the frequency-divided clock is supplied as the peripheral clock.

(7) Timer Units

Timer units include 16-bit timer array unit B (TAUB), 32-bit timer array unit J (TAUJ), timer S (TSG2), the encoder timer (ENCA), timer pattern buffer (TPBA), and OS timer (OST), and Window watchdog timer (WDTA) can provide capturing and comparison, measurement of pulse intervals and frequency, and programmable pulse output.

(8) Timer Option Units (TAPA)

These units control forcible stopping of the output from timers (TAUB, TSG2).

(9) Peripheral Interconnection (PIC)

Interlocking operation is available by connecting to a timer for simultaneous starting or peripheral I/O.

(10) Serial Interface (SIO)

Serial interfaces include synchronous/asynchronous interface H (UARTH), clocked serial interface (CSIG), and CAN.

UARTH executes data transfer through the UARTHnTXD and UARTHnRXD pins (n = 0, 1).

CSIG executes data transfer through the CSIGnSO, CSIGnSI, and CSIGnSC pins (n = 0, 1).

CAN executes data transfer through the FCNnRX and FCNnTX pins (n = 0, 1).

(11) Data CRC Function

Data CRC (cyclic redundancy checking) is used to verify or generate data streams protected by CRC with different widths in bits for various lengths.

(12) CLKOUT Function

A baud rate generator is included to allow output of desired frequencies from the CLKOUT pin.

(13) Nexus Function

A single Nexus channel is included as a debugging interface.

(14) LPD Function

A single-pin debugging interface is included as a debugging interface.

(15) A/D Converter (ADCA0)

The high-speed and high-resolution 12-bit A/D converters have 18 analog input pins.

(16) Ports

Port pins capable of operation as general-purpose port pins and as control pins are listed below.

Port	I/O	Control Function
Port 0	Bitwise I/O	Serial interface (UARTH0) I/O External interrupt (INTP0, INTP3 to INTP5) input A/D converter (ADCA0) input Baud rate generator (BRG0 (CLKOUT)) output
Port 1	Bitwise I/O	External interrupt (NMI, INTPO) input Baud rate generator (BRG0 (CLKOUT)) output Operating system timer (OST1) output Serial interface (CSIG0) I/O Serial interface (UARTH0) I/O Timer array unit J (TAUJ0) I/O Timer pattern buffer (TPBA0) output TSG2 (TSG20) output
Port 2	Bitwise I/O	Timer array unit B (TAUB0) I/O Serial interface (CSIG0, CSIG1) I/O Serial interface (UARTH1) I/O
Port 3	Bitwise I/O	External interrupt (INTP1, INTP2) input Serial interface (CSIG1) I/O Serial interface (UARTH1) I/O Serial interface (CAN1) I/O Timer pattern buffer (TPBA0) output
Port 4	Bitwise I/O	External interrupt (NMI, INTP1, INTP6 to INTP9) input Serial interface (CAN0) output Serial interface (CSIG0, CSIG1) I/O Serial interface (UARTH1) I/O Encoder timer (ENCA0) input TSG2 (TSG20) input A/D converter (ADCA0) output Timer option unit (TAPA0, TAPA2) input Operating system timer (OST0, OST1) output
Port 5	Bitwise I/O	External interrupt (INTP0, INTP3 to INTP5) input Serial interface (UARTH0) I/O A/D converter (ADCA0) input
Port 8	Bitwise I/O	Mode input Timer array unit B (TAUB0) output Operating system timer (OST1) output

Section 2 Port Functions

This section contains a generic description of the port control functions.

2.1 Port Functions

Port groups This product has the following numbers of port groups.

Table 2-1 Port Groups

Port Groups	
Product name	μPD70F4154 μPD70F4155
Number of port groups	7
Name	P0_0-P0_3, P1_0-P1_9, P2_0-P2_7, P3_0-P3_6, P4_0-P4_7, P5_0-P5_3, P8_0

Port groups index n Throughout this section, the individual port groups are identified by the index “n”, for example, PMCn for the port mode control register of Pn.

Register addresses All port n register addresses are given as address offsets from the individual base addresses <PORTn_base0> and <PORTn_base1>.

The base addresses <PORTn_base0> and <PORTn_base1> are specified in the following table.

Table 2-2 Port n Register Addresses <PORTn_base0> and <PORTn_base1>

<PORTn_base0> Address	<PORTn_base1> Address
FF40 0000 _H	FFFF 8000 _H

2.2 Overview

The microcontroller has various pins for input/output functions, known as ports.

The ports are organized in port groups.

The microcontroller also has several control registers to allocate non-general purpose input/output functions to the pins.

For a description of the terms pin, port, and port group, see Section 2.2.1, Terms.

- Features summary**
- I/O ports
 - Multiplexed with input/output pin functions for other peripheral modules
 - Able to specify input/output in bit units
 - Edge detection
 - Software pull-up
 - Noise cancellation

2.2.1 Terms

In this section, the following terms are used.

- **Pin**

Denotes the physical pin. Every pin is denoted by a unique pin number.

A pin can be switched to several modes for use.

The pin function allocated to a pin depends on the selected mode.

- **Port group**

Denotes a group of pins. The pins of a port group have a common set of port mode control registers.

- **Port mode/Port**

A pin in port mode works as a general purpose input/output pin. It is then called "port".

The corresponding name is P_n_m. For example, P0_1 denotes port 1 of port group 0. It is referenced as "port P0_1".

- **Alternative mode**

In alternative mode, a pin can be used for in various non-general purpose input/output functions, for example as the input/output pin of on-chip peripherals.

The corresponding pin name depends on the selected function.

For example, pin INTP0 denotes the pin for one of the external interrupt inputs.

Note that two different names can refer to the same physical pin, for example P0_0 and INTP0. The different names indicate the function in which the pin is being operated.

- **Port type**

"Port type" is set by setting a configuration register for the given port.

2.2.2 Pin Function Configuration

The pins can operate in three different general modes.

- Port mode (PMn.PMCn_m = 0)
In port mode, the pin operates as a general purpose I/O port. PMn.PMn_m selects input or output.
- Software I/O control alternative mode (PMn.PMCn_m = 1, PIPn.PIPCn_m = 0)
In software I/O control alternative mode, the pin is operated by an alternative function. The selection between input or output is done by software via the PMn.PMn_m control bits.
- Direct I/O control alternative mode (PMn.PMCn_m = 1, PIPn.PIPCn_m = 1)
In direct I/O control alternative mode, the pin operates for an alternative function. In contrast to the software I/O control alternative mode, input or output are also controlled by the hardware for the alternative function, so software settings are not required for this.

An overview of the register settings is given in the tables below.

Table 2-3 Pin Function Configuration (Overview)

Function	Register			I/O
	PMn_m	PMn_m	PIPn_m	
Port mode (Output)	0	0	X	O
Port mode (Input)		1*		I
Alternative output modes 1 to 4	1	0	0	O
Alternative input modes 1 to 4		1		I
Direct I/O control		X	1	Controlled by alternative function

Note: The input buffer must be enabled. (PIBCn.PIBCn_m = 1)

Note: X: Invalid setting

If a pin is operated in an alternative mode (PMn.PMCn_m = 1), one out of up to four different alternative functions can be selected by the PFCn and PFCEn registers.

- Software I/O control alternative functions (PIPn.PIPCn_m = 0)
 - Outputs (PMn_m = 0): ALT-OUT1 to ALT-OUT4
 - Inputs (PMn_m = 1): ALT-IN1 to ALT-IN4
- Direct I/O control alternative functions (PIPn.PIPCn_m = 1)
 - Input/output of ALT-OUT1 to ALT-OUT4 and ALT-IN1 to ALT-IN4 is directly controlled by the alternative function (hardware).

Table 2-4 Alternative Mode Selection Overview (PMCn.PMCn_m = 1)

Function	Register				I/O
	PIPC*	PM*	PFCE	PFC	
Alternative output mode 1 (ALT-OUT1)	0	0	0	0	O
Alternative input mode 1 (ALT-IN1)		1			I
Alternative output mode 2 (ALT-OUT2)		0	0	1	O
Alternative input mode 2 (ALT-IN2)		1			I
Alternative output mode 3 (ALT-OUT3)		0	1	0	O
Alternative input mode 3 (ALT-IN3)		1			I
Alternative output mode 4 (ALT-OUT4)		0	1	1	O
Alternative input mode 4 (ALT-IN4)		1			I

Note If PIPCn.PIPCn_m = 1, the I/O direction is directly controlled by the alternative function and PM is ignored.

Pins that have multiple functions multiplexed with a control mode (ALT-IN) and pins allocated to multiple port pins (excluding ESO2/INTP8) are listed in the following table.

-
- Caution 1. Do not use alternative function pins simultaneously (for example, ADCA0TRG0 and INTP3). However, edges for the INTP pins are detectable as the edges on the URTH0RXD, and URTH1RXD pins, respectively, in the case of the multiplexed pins for URTH0RXD/INTP0 and URTH1RXD/INTP1.
- Caution 2. Do not use the same alternative function pin with multiple port pins (For example, if ADCA0TRG0/INTP3 is in use, ALT_IN1 of P0_2, ALT_IN4 of P5_1, and so on).
-

Table 2-5 Pins on which a Single Control Mode and Multiple Alternate Functions are Multiplexed

Alternative Function Pin	Port Pin	Control Mode
ADCA0TRG0/INTP3	P0_2	ALT-IN1
	P5_1	ALT-IN4
	P5_3	ALT-IN2
ADCA0TRG1/INTP4	P0_1	ALT-IN1
	P5_2	ALT-IN4
ADCA0TRG2/INTP5	P0_0	ALT-IN1
	P5_3	ALT-IN4
ESO0/INTP6	P4_4	ALT-IN4
ESO2/INTP8	P4_6	ALT-IN4
URTH0RXD/INTP0	P0_0	ALT-IN4
	P1_7	ALT-IN4
	P5_0	ALT-IN3
URTH1RXD/INTP1	P3_0	ALT-IN3
	P4_0	ALT-IN1
TSG20PTSI0/ENCA0E0	P4_1	ALT-IN2
TSG20PTSI1/ENCA0E1	P4_2	ALT-IN2
TSG20PTSI2/ENCA0EC	P4_3	ALT-IN2

2.2.3 Pin Data Input/Output

The registers used for data input and output are described below.

The sources of the data for output and of data read via the PPRn register will differ with the pin mode.

- Output data** In port mode (PMcn.PMCn_m = 0), the data of Pn.Pn_m is output to pin Pn_m.
With a direct I/O control alternative function (PIPCn.PIPCn_m = 1), output is controlled by the alternative function.
- Input data** A read operation of the PPRn register returns either the value of the Pn_m pin, the associated bit of the port register Pn.Pn_m, or the data output by an alternative function. The source of the data read via PPRn depends on the pin mode and the setting of several control bits. The table below summarizes the different PPRn read modes.

Caution When the PCLK signal is at or above 64 MHz, secure at least 3 cycles of the PCLK before reading a PPR immediately after register settings are made and the input buffers for registers connected to the ports are enabled. Also, read the registers twice and discard the value read the first time.

Table 2-6 PPRn_m Read Values

PMcn_m	PMn_m	PIBCn_m	PIPCn_m	Mode	PPRn_m Read Value
0	1	0	x	Port input, input buffer disabled	Pn.Pn_m register
		1		Port input, input buffer enabled	Pn_m pin
	0	x	Port output	Pn.Pn_m register*1	
1	1	x	0	Input for alternative function under software I/O control	Pn_m pin
	0			Output for alternative function under software I/O control	Internal signal output for alternative function*2
	x		1	Input and output for alternative function under direct I/O control	If alternative functions sets port in <ul style="list-style-type: none"> input: PPRn_m = Pn_m pin output: PPRn_m = alternative function output*1,2

Note 1. If PBDCn_m = 1, the Pn_m pin level is read via PPRn_m.

Note 2. When the PPRn_m bit is read while PMcn_m = 1 for the internal signal output of an alternative function, the level read is not that on the Pn_m pin but the level of the internal signal for the alternative function.

The control registers in the table above have following effects:

- PBDCn.PBDCn_m
This bit forces to read the Pn_m pin level via PPRn_m, thus enabling a mode, where the level of pin Pn_m can also be read back if the port is operated in output mode.

- **PMn.PMCn_m**
This bit selects port mode (PMn_m = 0) or alternative mode (PMn_m = 1).
- **PMn.PMn_m**
This bit selects input (PMn_m = 1) or output (PMn_m = 0) in port mode (PMn_m = 0) and software I/O control alternative function mode (PMn_m = 1, PIPn_m = 0).
- **PIBn.PIBn_m**
This bit disables (PIBn_m = 0) or enables (PIBn_m = 1) the input buffer in input port mode (PMn_m = 0 and PMn_m = 1). If the input buffer is disabled, PPRn_m reads the Pn.Pn_m bit, otherwise the Pn_m pin level is returned.
- **PIPn.PIPn_m**
This bit selects between the software I/O control alternative function mode and direct I/O control alternative function.

Pn register write The data to be output via port Pn_m in port mode (PMn.PMCn_m = 0) is held in the port register Pn. The Pn data can be manipulated in two different ways:

- **Direct Pn write**
New data can be written directly to the Pn register.
- **Indirect Pn bit set/reset/not**
An indirect way to set (Pn_m = 1), reset (Pn_m = 0), or invert ($\overline{Pn_m} \rightarrow Pn_m$) a Pn bit is possible using the following two registers:
 - **Port set reset register PSRn**
If the bit PSRn.PSRn_(m+16) = 1, the value of bit PSRn.PSRn_m determines the value of Pn.Pn_m. Thus Pn_m can be set/reset without a direct write to Pn.
 - **Port NOT register PNOTn**
Setting PNOTn.PNOTn_m = 1 inverts the bit Pn.Pn_m without a direct write to Pn_m.

Access to single bits of the Pn register is possible so that operations to manipulate (set, reset,) bits for the Pn register do not indirectly affect any of the other Pn_m bits.

Take care because the simultaneous use of both methods to manipulate Pn_m bits is possible.

Caution When the following conditions are satisfied, the output on the Pn_m pin (e.g. ALT_OUTx) reflects the internal level of a multiplexed input function (e.g. ALT_INx).

An output function (e.g. ALT_OUTx) is multiplexed with an input function (e.g. ALT_INx).

The pin is in use for the multiplexed output function (PMn.PMCn_m = 1 and PMn.PMn_m = 0).

Enabling of the bi-directional mode (PBDCn.PBDCn_m = 1) leads to the level on Pn_m being readable from PPRn.PPRn_m.

2.2.4 Port Control Logic Diagram

The following figure shows the logic diagram of the port control function.

Caution This figure shows the logics for reference; not show the actual circuits.

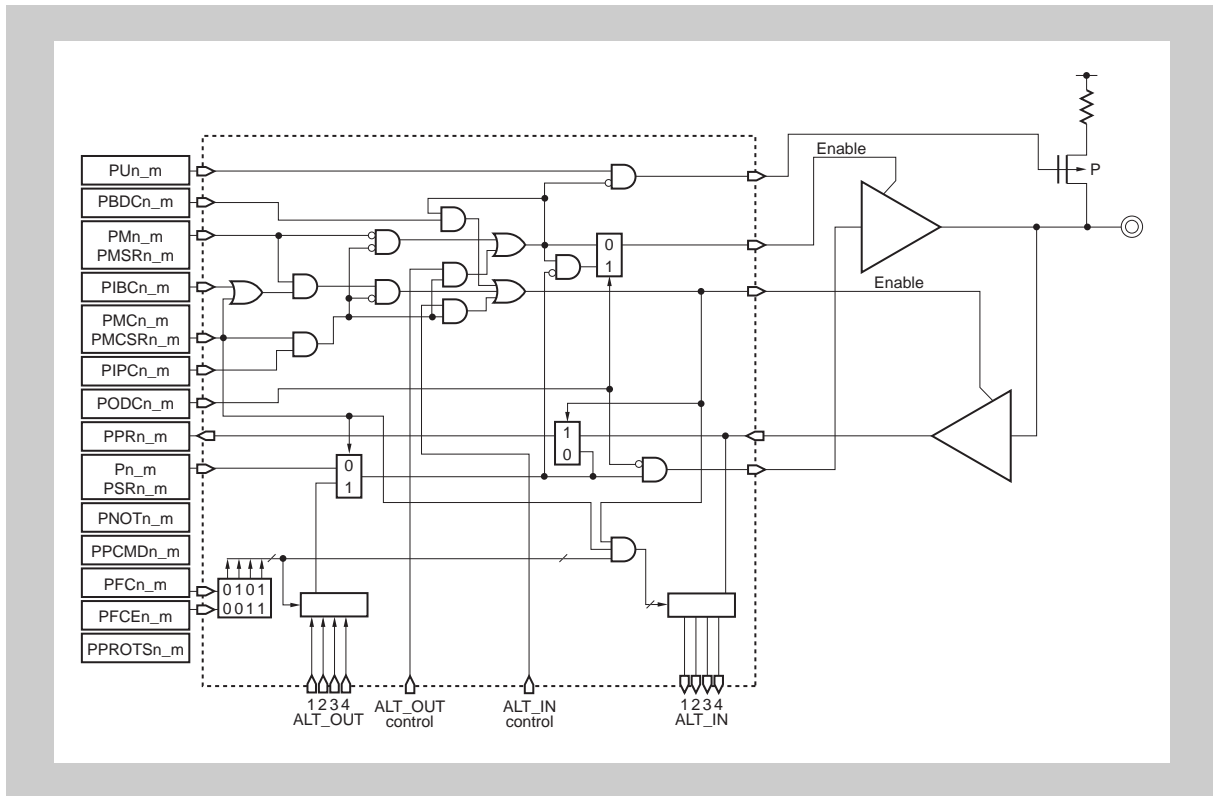

2.3 Port Group Configuration Registers

This section starts with an overview of all configuration registers, and then presents all registers in detail. The configuration registers are grouped as follows:

- 2.3.2 Pin Function Configuration Registers
- 2.3.3 Pin Data Input/Output Registers
- 2.3.4 Configuration of Electrical Characteristics Registers

2.3.1 Overview

The following registers are used for the configuration of the individual pins of the port groups.

Table 2-7 Port Group Configuration Registers

Register Name	Shortcut	Address
Port input buffer control register	PIBCn	<PORTn_base0> + 400 _H + n × 4
Port bi-direction control register	PBDCn	<PORTn_base0> + 410 _H + n × 4
Port IP control register	PIPCn	<PORTn_base0> + 420 _H + n × 4
Pull-up option register	PUn	<PORTn_base0> + 430 _H + n × 4
Port open drain control register	PODCn	<PORTn_base0> + 450 _H + n × 4
Port register protection command register	PPCMDn	<PORTn_base0> + 4C0 _H + n × 4
Port protection status register	PPROTSn	<PORTn_base0> + 4B0 _H + n × 4
Port register	Pn	<PORTn_base1> + n × 4
Port set reset register	PSRn	<PORTn_base1> + 100 _H + n × 4
Port pin read register	PPRn	<PORTn_base1> + 200 _H + n × 4
Port mode register	PMn	<PORTn_base1> + 300 _H + n × 4
Port mode control register	PMCn	<PORTn_base1> + 400 _H + n × 4
Port function control register	PFCn	<PORTn_base1> + 500 _H + n × 4
Port function control expansion register	PFCEn	<PORTn_base1> + 600 _H + n × 4
Port NOT register	PNOTn	<PORTn_base1> + 700 _H + n × 4
Port mode set register	PMSRn	<PORTn_base1> + 800 _H + n × 4
Port mode control set register	PMCSRn	<PORTn_base1> + 900 _H + n × 4

<PORTn_base> The base address <PORT_base> of the port control registers is defined in Table 2-2, Port n Register Addresses <PORTn_base0> and <PORTn_base1>.

Table 2-8 JTAG Port Group Configuration Registers

Register Name	Shortcut	Address
JTAG port register	JP0	FF44 0000 _H
JTAG port set reset register	JPSR0	FF44 0010 _H
JTAG port pin read register	JPPR0	FF44 0020 _H
JTAG port mode register	JPM0	FF44 0030 _H
JTAG port NOT register	JPNOT0	FF44 0070 _H
JTAG port mode set register	JPMSR0	FF44 0080 _H
JTAG port input buffer control register	JPIBC0	FF44 0400 _H
JTAG pull-up option register	JPU0	FF44 0430 _H

Note For details of the JTAG port group configuration registers, see Section 2.3.2, Pin Function Configuration Registers, Section 2.3.3, Pin Data Input/Output Registers, and Section 2.3.4, Configuration of Electrical Characteristics Registers. The valid bits and access size of the JTAG port group configuration registers are shown in Table 2-48, List of JTAG Port 0 Control Registers.

Caution Many registers include bits to which no function has been allocated. Unless there is a specific indication to the contrary, do not write values other than the initial values to such bits. Operation is not guaranteed if other values are set in these bits.

2.3.2 Pin Function Configuration Registers

(1) PMCn – Port Mode Control Register

This register specifies whether the individual pins of port group n are in port mode or in alternative mode (n = 0 to 5, 8).

Access Readable and writable in 16-bit units.

Address Refer to Table 2-7, Port Group Configuration Registers.

Initial value 0000_H

A reset from any source will initialize the bits.

15	14	13	12	11	10	9	8	7	6	5	4	3	2	1	0
PMCn_15	PMCn_14	PMCn_13	PMCn_12	PMCn_11	PMCn_10	PMCn_9	PMCn_8	PMCn_7	PMCn_6	PMCn_5	PMCn_4	PMCn_3	PMCn_2	PMCn_1	PMCn_0
R/W	R/W	R/W	R/W	R/W	R/W	R/W	R/W	R/W	R/W	R/W	R/W	R/W	R/W	R/W	R/W

Table 2-9 PMCn Register Contents

Bit Position	Bit Name	Function
15 to 0	PMCn_[15:0]	Specifies the operation mode of the corresponding pin. 0: Port mode 1: Alternative mode

(2) PMCSRn – Port Mode Control Set Reset Register n

This register provides an alternative method to write data to the PMCn register.

The upper 16 bits specify whether the value PMCn.PMCn_m is set by a write operation to PMCn.PMCn_m or is defined by the lower 16 bits of PMCSRn (n = 0 to 5, 8).

Access Readable and writable in 32-bit units.
Bits 31 to 16 are always read as 0000_H.
Reading bits 15 to 0 returns the value of register PMCn.

Address Refer to Table 2-7, Port Group Configuration Registers.

Initial value 0000 0000_H

A reset from any source will initialize the bits.

31	30	29	28	27	26	25	24	23	22	21	20	19	18	17	16
PMCS Rn_31	PMCS Rn_30	PMCS Rn_29	PMCS Rn_28	PMCS Rn_27	PMCS Rn_26	PMCS Rn_25	PMCS Rn_24	PMCS Rn_23	PMCS Rn_22	PMCS Rn_21	PMCS Rn_20	PMCS Rn_19	PMCS Rn_18	PMCS Rn_17	PMCS Rn_16
R/W	R/W	R/W	R/W	R/W	R/W	R/W	R/W	R/W	R/W	R/W	R/W	R/W	R/W	R/W	R/W
15	14	13	12	11	10	9	8	7	6	5	4	3	2	1	0
PMCS Rn_15	PMCS Rn_14	PMCS Rn_13	PMCS Rn_12	PMCS Rn_11	PMCS Rn_10	PMCS Rn_9	PMCS Rn_8	PMCS Rn_7	PMCS Rn_6	PMCS Rn_5	PMCS Rn_4	PMCS Rn_3	PMCS Rn_2	PMCS Rn_1	PMCS Rn_0
R/W	R/W	R/W	R/W	R/W	R/W	R/W	R/W	R/W	R/W	R/W	R/W	R/W	R/W	R/W	R/W

Table 2-10 PMCSRn Register Contents

Bit Position	Bit Name	Function
31 to 16	PMCSRn_[31:16]	PMCSRn_m specifies whether the value of the corresponding lower bit PMCSRn_m value is written to PMCn_m. 0: PMCn_m is independent of PMCSRn_m 1: PMCn_m is PMCSRn_m Example: If PMCSRn.PMCSRn_31 = 1, the value of bit PMCSRn.PMCSRn_15 is written to bit PMCn.PMCn_15.
15 to 0	PMCSRn_[15:0]	Specifies the PMCn_m value if the corresponding upper bit PMCSRn_(m + 16) is 1. 0: PMCn_m = 0 1: PMCn_m = 1

(3) PIPCN – Port IP Control Register

This register specifies whether the I/O direction of pin Pn_m is controlled by the port mode register PMn.PMn_m or by an alternative function.

If pin Pn_m is operated in alternative mode (PMcn.PMCn_m = 1) and the alternative function requires to directly control the I/O direction of Pn_m, PIPCN.PIPCn_m must be set to 1 as well. This hands over I/O control to the alternative function and overrules the PMn.PMn_m setting (n = 0 to 5).

Access Readable and writable in 16-bit units.

Address Refer to Table 2-7, Port Group Configuration Registers

Initial value 0000_H

A reset from any source will initialize the bits.

15	14	13	12	11	10	9	8	7	6	5	4	3	2	1	0
PIPC n_15	PIPC n_14	PIPC n_13	PIPC n_12	PIPC n_11	PIPC n_10	PIPC n_9	PIPC n_8	PIPC n_7	PIPC n_6	PIPC n_5	PIPC n_4	PIPC n_3	PIPC n_2	PIPC n_1	PIPC n_0
R/W	R/W	R/W	R/W	R/W	R/W	R/W	R/W	R/W	R/W	R/W	R/W	R/W	R/W	R/W	R/W

Table 2-11 PIPCN Register Contents

Bit Position	Bit Name	Function
15 to 0	PIPCn_[15:0]	Specifies the I/O control mode. 0: I/O mode is selected by PMn.PMn_m (software I/O control). 1: I/O mode is selected by the peripheral function (direct I/O control).

- Caution 1. The following pins control buffer I/O from peripheral I/O. Set PIPCN to 1 if any of these pins is to be used.
- CSIGNSC, URTHnSC
(serial clock input/output pins)
As long as the direction (input or output) is set correctly in the PMn register, i.e. so that it corresponds to the setting for master or slave mode of the serial interface (PMn_m = 0 for master mode and PMn_m = 1 for slave mode), setting the corresponding bit in the PIPCN register to 0 does not create a problem.
 - TAUB0O10 to TAUB0O15, TSG20O1 to TSG20O6
(target pins for Hi-Z control)
When a pin is to be used as a timer output pin for the timer option function (TAPA) and Hi-Z control is not to be applied, setting the corresponding bit in the PIPCN register to 0 (PMn_m = 0) does not create a problem as long as the pin is set as an output pin in the PMn register.
- Caution 2. To use the data consistency checking function of the CSIG module, set the bit in the PIPCN register that is allocated to the CSIGNSO pin to 0 (operation of data consistency checking is not guaranteed if the bit is set to 1).

(4) PMn – Port Mode Register

The PMn register specifies whether the individual pins of the port group n are in input mode or in output mode (n = 0 to 5, 8).

Access Readable and writable in 16-bit units.

Address Refer to Table 2-7, Port Group Configuration Registers.

Initial value FFFF_H

A reset from any source will initialize the bits.

15	14	13	12	11	10	9	8	7	6	5	4	3	2	1	0
PMn_ 15	PMn_ 14	PMn_ 13	PMn_ 12	PMn_ 11	PMn_ 10	PMn_ 9	PMn_ 8	PMn_ 7	PMn_ 6	PMn_ 5	PMn_ 4	PMn_ 3	PMn_ 2	PMn_ 1	PMn_ 0
R/W	R/W	R/W	R/W	R/W	R/W	R/W	R/W	R/W	R/W	R/W	R/W	R/W	R/W	R/W	R/W

Table 2-12 PMn Register Contents

Bit Position	Bit Name	Function
15 to 0	PMn_[15:0]	Specifies input/output mode of the corresponding pin. 0: Output mode (output enabled) 1: Input mode (output disabled)

- Note 1. To use a port in input port mode (PMCn.PMCn_m = 0 and PMn.PMn_m = 1), the input buffer must be enabled (PIBCn.PIBCn_m = 1).
- Note 2. By default, PMn_m, it specifies the I/O direction in port mode (PMCn.PMCn_m = 0) and alternative mode (PMCn.PMCn_m=1), since PIPCn.PIPCn_m = 0 after reset.

(5) PMSRn – Port Mode Set Reset Register n

This register provides an alternative method to write data to the PMn register.

The upper 16 bits specify whether the value PMn.PMn_m is set by a write operation to PMn.PMn_m or is defined by the lower 16 bits of PMSRn (n = 0 to 5, 8).

Access Readable and writable in 32-bit units.
 Bits 31 to 16 are always read as 0000_H.
 Reading bits 15 to 0 returns the value of register PMn.

Address Refer to Table 2-7, Port Group Configuration Registers.

Initial value 0000FFFF_H

A reset from any source will initialize the bits.

31	30	29	28	27	26	25	24	23	22	21	20	19	18	17	16
PMSR n_31	PMSR n_30	PMSR n_29	PMSR n_28	PMSR n_27	PMSR n_26	PMSR n_25	PMSR n_24	PMSR n_23	PMSR n_22	PMSR n_21	PMSR n_20	PMSR n_19	PMSR n_18	PMSR n_17	PMSR n_16
R/W	R/W	R/W	R/W	R/W	R/W	R/W	R/W	R/W	R/W	R/W	R/W	R/W	R/W	R/W	R/W
15	14	13	12	11	10	9	8	7	6	5	4	3	2	1	0
PMSR n_15	PMSR n_14	PMSR n_13	PMSR n_12	PMSR n_11	PMSR n_10	PMSR n_9	PMSR n_8	PMSR n_7	PMSR n_6	PMSR n_5	PMSR n_4	PMSR n_3	PMSR n_2	PMSR n_1	PMSR n_0
R/W	R/W	R/W	R/W	R/W	R/W	R/W	R/W	R/W	R/W	R/W	R/W	R/W	R/W	R/W	R/W

Table 2-13 PMSRn Register Contents

Bit Position	Bit Name	Function
31 to 16	PMSRn_[31:16]	PMSRn_m specifies whether the value of the corresponding lower bit PMSRn_m value is written to PMn_m. 0: PMn_m is independent of PMSRn_m 1: PMn_m is PMSRn_m Example: If PMSRn.PMSRn_31 = 1, the value of bit PMSRn.PMSRn_15 is written to bit PMn.PMn_15.
15 to 0	PMSRn_[15:0]	Specifies the PMn_m value if the corresponding upper bit PMSRn_(m + 16) is 1. 0: PMn_m = 0 1: PMn_m = 1

(6) PIBCn – Port Input Buffer Control Register

In input port mode (PMnCn.PMCn_m = 0 and PMn.PMn_m = 1), this register enables/disables the port pin's input buffer (n = 0 to 5, 8).

Access Readable and writable in 16-bit units.

Address Refer to Table 2-7, Port Group Configuration Registers.

Initial value 0000_H

A reset from any source will initialize the bits.

15	14	13	12	11	10	9	8	7	6	5	4	3	2	1	0
PIBC n_15	PIBC n_14	PIBC n_13	PIBC n_12	PIBC n_11	PIBC n_10	PIBC n_9	PIBC n_8	PIBC n_7	PIBC n_6	PIBC n_5	PIBC n_4	PIBC n_3	PIBC n_2	PIBC n_1	PIBC n_0
R/W	R/W	R/W	R/W	R/W	R/W	R/W	R/W	R/W	R/W	R/W	R/W	R/W	R/W	R/W	R/W

Table 2-14 PIBCn Register Contents

Bit Position	Bit Name	Function
15 to 0	PIBCn_[15:0]	Enables/disables the input buffer. 0: Input buffer disabled 1: Input buffer enabled

Caution Settings in this register are overruled in bi-directional mode (PBDCn.PBDCn_m = 1).

(7) PFCn – Port Function Control Register

This register, together with register PFCEn, specifies an alternative function of the pins.

Some alternative functions require direct I/O control of pin Pn_m. For such alternative functions PIPCN.PIPCn_m must be set to 1 as well.

For other alternative functions, input/output must be specified by PMn.PMn_m (n = 0 to 5, 8).

Access Readable and writable in 16-bit units.

Address Refer to Table 2-7, Port Group Configuration Registers.

Initial value 0000_H

A reset from any source will initialize the bits.

15	14	13	12	11	10	9	8	7	6	5	4	3	2	1	0
PFC n_15	PFC n_14	PFC n_13	PFC n_12	PFC n_11	PFC n_10	PFC n_9	PFC n_8	PFC n_7	PFC n_6	PFC n_5	PFC n_4	PFC n_3	PFC n_2	PFC n_1	PFC n_0
R/W	R/W	R/W	R/W	R/W	R/W	R/W	R/W	R/W	R/W	R/W	R/W	R/W	R/W	R/W	R/W

Table 2-15 PFCn Register Contents

Bit Position	Bit Name	Function
15 to 0	PFCn_[15:0]	Specifies the alternative function of a pin. See Table 2-4, Alternative Mode Selection Overview (PMcn.PMCn_m = 1).

(8) PFCEn – Port Function Control Expansion Register

This register, together with register PFCn, specifies an alternative function of the pins.

Some alternative functions require direct I/O control of pin Pn_m. For such alternative functions PIPCN.PIPCn_m must be set to 1 as well.

For other alternative functions, input/output must be specified by PMn.PMn_m (n = 0 to 5, 8).

Access Readable and writable in 16-bit units.

Address Refer to Table 2-7, Port Group Configuration Registers.

Initial value 0000_H

A reset from any source will initialize the bits.

15	14	13	12	11	10	9	8	7	6	5	4	3	2	1	0
PFCE n_15	PFCE n_14	PFCE n_13	PFCE n_12	PFCE n_11	PFCE n_10	PFCE n_9	PFCE n_8	PFCE n_7	PFCE n_6	PFCE n_5	PFCE n_4	PFCE n_3	PFCE n_2	PFCE n_1	PFCE n_0
R/W	R/W	R/W	R/W	R/W	R/W	R/W	R/W	R/W	R/W	R/W	R/W	R/W	R/W	R/W	R/W

Table 2-16 PFCEn Register Contents

Bit Position	Bit Name	Function
15 to 0	PFCEn_[15:0]	Specifies the alternative function of a pin. See table Table 2-4, Alternative Mode Selection Overview (PMcn.PMCn_m = 1).

2.3.3 Pin Data Input/Output Registers

(1) PBDCn – Port Bi-Direction Control Register

This register enables the input buffer, thus the Pn_m pin level is always read via PPRn.PPRn_m (n = 0 to 5, 8).

Access Readable and writable in 16-bit units.

Address Refer to Table 2-7, Port Group Configuration Registers

Initial value 0000_H

A reset from any source will initialize the bits.

15	14	13	12	11	10	9	8	7	6	5	4	3	2	1	0
PBDC n_15	PBDC n_14	PBDC n_13	PBDC n_12	PBDC n_11	PBDC n_10	PBDC n_9	PBDC n_8	PBDC n_7	PBDC n_6	PBDC n_5	PBDC n_4	PBDC n_3	PBDC n_2	PBDC n_1	PBDC n_0
R/W	R/W	R/W	R/W	R/W	R/W	R/W	R/W	R/W	R/W	R/W	R/W	R/W	R/W	R/W	R/W

Table 2-17 PBDCn Register Contents

Bit Position	Bit Name	Function
15 to 0	PBDCn_[15:0]	Enables/disables bi-directional mode of the corresponding pin. 0: Bi-directional mode disabled 1: Bi-directional mode enabled

Caution To use the data-consistency checking function of the CSIG module, set the bit in the PBDCn register that is allocated to the CSIGnSO pin to 1.

(2) PPRn – Port Pin Read Register

This register reflects the actual level of pin Pn_m, the value of the Pn.Pn_m bit or the level of an alternative output function. The value which is read depends on various control settings as described in Table 2-6, PPRn_m Read Values (n = 0 to 5, 8).

Access This register is read-only and only readable in 16-bit units.

Address Refer to Table 2-7, Port Group Configuration Registers.

Initial value 0000_H

A reset from any source will initialize the bits.

15	14	13	12	11	10	9	8	7	6	5	4	3	2	1	0
PPR n_15	PPR n_14	PPR n_13	PPR n_12	PPR n_11	PPR n_10	PPR n_9	PPR n_8	PPR n_7	PPR n_6	PPR n_5	PPR n_4	PPR n_3	PPR n_2	PPR n_1	PPR n_0
R	R	R	R	R	R	R	R	R	R	R	R	R	R	R	R

Table 2-18 PPRn Register Contents

Bit Position	Bit Name	Function
15 to 0	PPRn_[15:0]	Pin Pn_m, Pn.Pn_m value or alternative function output.

(3) Pn – Port Register

This register holds the data Pn.Pn_m to be output via the related port Pn_m in output port mode (PMcn.PMCn_m = 0 and PMn.PMn_m = 0) (n = 0 to 5, 8).

Access Readable and writable in 16-bit units.

Address Refer to Table 2-7, Port Group Configuration Registers.

Initial value 0000_H

A reset from any source will initialize the bits.

15	14	13	12	11	10	9	8	7	6	5	4	3	2	1	0
Pn_15	Pn_14	Pn_13	Pn_12	Pn_11	Pn_10	Pn_9	Pn_8	Pn_7	Pn_6	Pn_5	Pn_4	Pn_3	Pn_2	Pn_1	Pn_0
R/W	R/W	R/W	R/W	R/W	R/W	R/W	R/W	R/W	R/W	R/W	R/W	R/W	R/W	R/W	R/W

Table 2-19 Pn Register Contents

Bit Position	Bit Name	Function
15 to 0	Pn_[15:0]	Sets the output level of pin m (m = 0 to 15). 0: Outputs low level 1: Outputs high level

Note The bits of this register can be manipulated by different means; refer to Section 2.2.3, Pin Data Input/Output.

(4) PNOTn – Port NOT Register

This register allows to invert a bit Pn_m of the port register Pn without directly writing to Pn (n = 0 to 5, 8).

Access Writing in 16-bit units is the only form of access. The register is always read as 0000_H.

Address Refer to Table 2-7, Port Group Configuration Registers.

Initial value 0000_H

A reset from any source will initialize the bits.

15	14	13	12	11	10	9	8	7	6	5	4	3	2	1	0
PNOT n_15	PNOT n_14	PNOT n_13	PNOT n_12	PNOT n_11	PNOT n_10	PNOT n_9	PNOT n_8	PNOT n_7	PNOT n_6	PNOT n_5	PNOT n_4	PNOT n_3	PNOT n_2	PNOT n_1	PNOT n_0
W	W	W	W	W	W	W	W	W	W	W	W	W	W	W	W

Table 2-20 PNOTn Register Contents

Bit Position	Bit Name	Function
15 to 0	PNOTn_[15:0]	Specifies if Pn.Pn_m is inverted: 0: Pn.Pn_m is not inverted (Pn_m → Pn_m) 1: Pn.Pn_m is inverted (Pn_m → Pn_m)

(5) PSRn – Port Set Reset Register

This register provides an alternative method to write data to the Pn register.

The upper 16 bits specify whether the value Pn.Pn_m is set by a write operation to Pn.Pn_m or is defined by the lower 16 bits of PSRn (n = 0 to 5, 8).

Access Readable and writable in 32-bit units.
 Bits 31 to 16 are always read as 0000_H.
 Reading bits 15 to 0 returns the value of register Pn.

Address Refer to Table 2-7, Port Group Configuration Registers.

Initial value 0000 0000_H

A reset from any source will initialize the bits.

31	30	29	28	27	26	25	24	23	22	21	20	19	18	17	16
PSR n_31	PSR n_30	PSR n_29	PSR n_28	PSR n_27	PSR n_26	PSR n_25	PSR n_24	PSR n_23	PSR n_22	PSR n_21	PSR n_20	PSR n_19	PSR n_18	PSR n_17	PSR n_16
R/W	R/W	R/W	R/W	R/W	R/W	R/W	R/W	R/W	R/W	R/W	R/W	R/W	R/W	R/W	R/W
15	14	13	12	11	10	9	8	7	6	5	4	3	2	1	0
PSR n_15	PSR n_14	PSR n_13	PSR n_12	PSR n_11	PSR n_10	PSR n_9	PSR n_8	PSR n_7	PSR n_6	PSR n_5	PSR n_4	PSR n_3	PSR n_2	PSR n_1	PSR n_0
R/W	R/W	R/W	R/W	R/W	R/W	R/W	R/W	R/W	R/W	R/W	R/W	R/W	R/W	R/W	R/W

Table 2-21 PSRn Register Contents

Bit Position	Bit Name	Function
31 to 16	PSRn_[31:16]	PSRn_m specifies whether the value of the corresponding lower bit PSRn_m value is written to Pn_m. 0: Pn_m is independent of PSRn_m 1: Pn_m is PSRn_m Example: If PSRn.PSRn31 = 1, the value of bit PSRn.PSRn_15 is written to bit Pn.Pn_15.
15 to 0	PSRn_[15:0]	Specifies the Pn_m value if the corresponding upper bit PSRn_(m+16) is 1. 0: Pn_m = 0 1: Pn_m = 1

2.3.4 Configuration of Electrical Characteristics Registers

(1) PUn – Pull-Up Option Register

This register specifies whether pull-up resistor is connected to an input pin (n = 0 to 5, 8).

Access Readable and writable in 16-bit units.

Address Refer to Table 2-7, Port Group Configuration Registers.

Initial value 0000_H

A reset from any source will initialize the bits.

15	14	13	12	11	10	9	8	7	6	5	4	3	2	1	0
PUn_15	PUn_14	PUn_13	PUn_12	PUn_11	PUn_10	PUn_9	PUn_8	PUn_7	PUn_6	PUn_5	PUn_4	PUn_3	PUn_2	PUn_1	PUn_0
R/W	R/W	R/W	R/W	R/W	R/W	R/W	R/W	R/W	R/W	R/W	R/W	R/W	R/W	R/W	R/W

Table 2-22 PUn Register Contents

Bit Position	Bit Name	Function
15 to 0	PUn_[15:0]	Specifies whether a pull-up resistor is connected to the corresponding pin. 0: No pull-up resistor connected 1: Pull-up resistor connected

Caution The pull-up resistor has no effect when the pin is operated in output mode.

(2) PODCn – Port Open Drain Control Register

This register selects push-pull or open-drain as output buffer function ($n = 2$). For correspondence with the SPC function of the SENT interface in this product, this setting is only available for the TAUB0 pin of port 2.

Access Readable and writable in 32-bit units.

Writing to this register is protected by a special sequence of instructions. Refer to Section 2.3.5, Port Register Protection.

Address Refer to Table 2-7, Port Group Configuration Registers.

Initial value 0000 0000_H

A reset from any source will initialize the bits.

31	30	29	28	27	26	25	24	23	22	21	20	19	18	17	16
PODC n_31	PODC n_30	PODC n_29	PODC n_28	PODC n_27	PODC n_26	PODC n_25	PODC n_24	PODC n_23	PODC n_22	PODC n_21	PODC n_20	PODC n_19	PODC n_18	PODC n_17	PODC n_16
R/W	R/W	R/W	R/W	R/W	R/W	R/W	R/W	R/W	R/W	R/W	R/W	R/W	R/W	R/W	R/W
15	14	13	12	11	10	9	8	7	6	5	4	3	2	1	0
PODC n_15	PODC n_14	PODC n_13	PODC n_12	PODC n_11	PODC n_10	PODC n_9	PODC n_8	PODC n_7	PODC n_6	PODC n_5	PODC n_4	PODC n_3	PODC n_2	PODC n_1	PODC n_0
R/W	R/W	R/W	R/W	R/W	R/W	R/W	R/W	R/W	R/W	R/W	R/W	R/W	R/W	R/W	R/W

Table 2-23 PODCn Register Contents

Bit Position	Bit Name	Function
31 to 0	PODCn_[31:0]	Specifies the output buffer function. 0: Push-pull 1: Open-drain

2.3.5 Port Register Protection

(1) PPCMDn – Port Register Protection Command Register

This register is a command register for (n = 2).

Access Writable in 8-bit units. When read, it is always read as 0.

Address Refer to Table 2-7, Port Group Configuration Registers.

Initial value 00_H

A reset from any source will initialize the bits.

7	6	5	4	3	2	1	0
0	0	0	0	0	0	0	0
W	W	W	W	W	W	W	W

Table 2-24 PPCMDm Register Contents

Bit Position	Bit Name	Function
7 to 0	—	Command capable of writing to protected port registers

(2) PPROTSn – Port Protection Status Registers

This register shows the state of the write sequence for a protected port register (n = 2).

Access Readable in 8-bit units. Values written are ignored.

Address Refer to Table 2-7, Port Group Configuration Registers.

Initial value 00_H

A reset from any source will initialize the bits.

7	6	5	4	3	2	1	0
0	0	0	0	0	0	0	PPROTSn_0
R	R	R	R	R	R	R	R

Table 2-25 PPROTSn Register Contents

Bit Position	Bit Name	Function
0	PPROTSn_0	Confirms errors in the write sequence for a protected port register. 0: No protection error occurred 1: Protection error occurred

(3) Protected Port Registers

PODCn - Port Open Drain Control Register

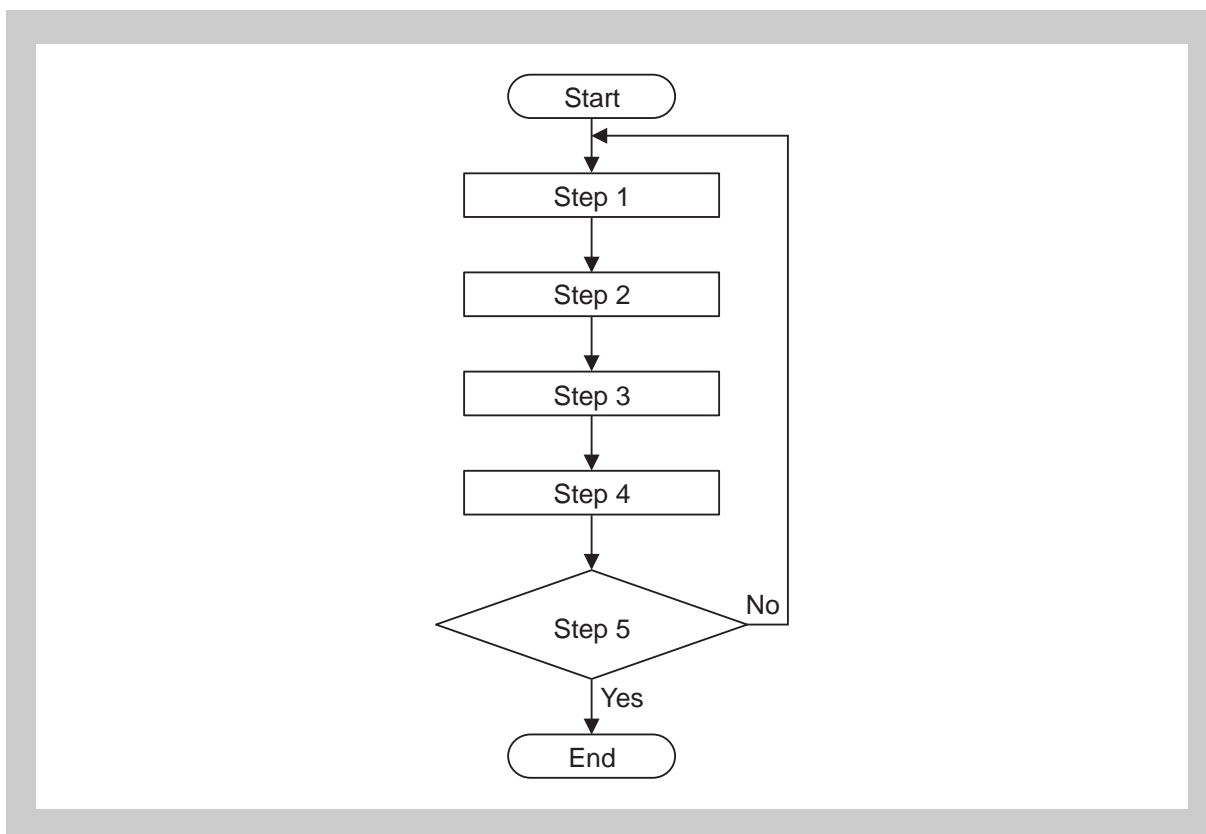
(4) Sequence for Writing to a Protected Port Register**Figure 2-1 Sequence for Writing to a Protected Port Register**

- Step 1** Initialize the sequence of writing by writing $A5_H$ to register PPCMD.
- Step 2** Write the set value in a 32-bit unit to a protected register (this will not update the register).
- Step 3** Write the inverse of the set value in a 32-bit unit to the same protected register (this will not update the register).
- Step 4** Again write the original set value in a 32-bit unit to the same protected register (this will update the register).
- Step 5** Check if the value in the PPROTSn.PPROTSn_0 bit is 0; this will confirm that the set value has actually been written to the protected port register.

2.4 Port Group Configuration

This section shows an overview of the port groups. See Table 2-26, List of Port Groups.

Table 2-30, List of States of Port Pins, shows the changes in pin function when this microcontroller is reset, or is at each stand-by mode.

In each sub-section, the configuration register settings of each port group are listed (see Section 2.6, Port 0, and subsequent passages).

2.4.1 List of Ports and Pins

(1) List of Port Groups

Table 2-26 List of Port Groups (1/2)

Port Group Name	Port Name	Alternative Mode 1	Alternative Mode 2	Alternative Mode 3	Alternative Mode 4	Characteristics
P0	P0_0	ADCA0TRG2/ INTP5	—	—	URTH0RXD/ INTP0	<ul style="list-style-type: none"> Input/output port Inputs and outputs are specifiable in 1-bit units.
	P0_1	ADCA0TRG1/ INTP4	—	—	URTH0TXD	
	P0_2	ADCA0TRG0/ INTP3	—	—	URTH0SC	
	P0_3	CLKOUT	—	—	URTH0CTS	
P1	P1_0	NMI/ CLKOUT	OSTM10	—	TSG2007	<ul style="list-style-type: none"> Input/output port Inputs and outputs are specifiable in 1-bit units.
	P1_1	TAUJ0I0/ TAUJ0O0	—	—	TSG2001	
	P1_2	TAUJ0I1/ TAUJ0O1	—	—	TSG2002	
	P1_3	TAUJ0I2/ TAUJ0O2	—	—	TSG2003	
	P1_4	TAUJ0I3/ TAUJ0O3	—	—	TSG2004	
	P1_5	—	—	—	TSG2005	
	P1_6	—	—	—	TSG2006	
	P1_7	—	CSIG0SI	—	URTH0RXD/ TSG2007/ INTP0	
	P1_8	TPB00	CSIG0SO	—	URTH0TXD	
	P1_9	—	CSIG0SC	—	URTH0SC	
P2	P2_0	TAUB0I1/ TAUB0O1	TAUB0I0/ TAUB0O0	URTH1SC	CSIG0RYI	<ul style="list-style-type: none"> Input/output port Inputs and outputs are specifiable in 1-bit units.
	P2_1	TAUB0I3/ TAUB0O3	TAUB0I2/ TAUB0O2	—	CSIG1RYI	
	P2_2	TAUB0I5/ TAUB0O5	TAUB0I4/ TAUB0O4	TAUB0O10	—	
	P2_3	TAUB0I7/ TAUB0O7	TAUB0I6/ TAUB0O6	TAUB0O12	—	
	P2_4	TAUB0I9/ TAUB0O9	TAUB0I8/ TAUB0O8	TAUB0O14	—	
	P2_5	TAUB0I11/ TAUB0O11	TAUB0I10/ TAUB0O10	—	—	
	P2_6	TAUB0I13/ TAUB0O13	TAUB0I12/ TAUB0O12	—	—	
	P2_7	TAUB0I15/ TAUB0O15	TAUB0I14/ TAUB0O14	—	—	

Table 2-26 List of Port Groups (2/2)

Port Group Name	Port Name	Alternative Mode 1	Alternative Mode 2	Alternative Mode 3	Alternative Mode 4	Characteristics
P3	P3_0	—	—	URTH1RXD/ INTP1	—	<ul style="list-style-type: none"> Input/output port Inputs and outputs are specifiable in 1-bit units.
	P3_1	—	—	URTH1TXD	—	
	P3_2	—	—	CSIG1SI	—	
	P3_3	—	—	CSIG1SO	TPB00	
	P3_4	—	—	CSIG1SC	—	
	P3_5	—	—	—	INTP2/ FCN1TX	
	P3_6	—	—	—	FCN1RX	
P4	P4_0	URTH1RXD/ INTP1	—	FCN0TX	—	<ul style="list-style-type: none"> Input/output port Inputs and outputs are specifiable in 1-bit units.
	P4_1	URTH1TXD	TSG20PTSI0/ ENCA0E0	FCN0RX	—	
	P4_2	CSIG1SI	TSG20PTSI1/ ENCA0E1/ OSTM1O	—	—	
	P4_3	CSIG1SO	TSG20PTSI2/ ENCA0EC/ OSTM0O	URTH1CTS	—	
	P4_4	CSIG1SC	—	URTH1RTS	ESO0/ INTP6/ CSIG0RYO	
	P4_5	—	—	ADCA0CNV2	INTP7/ CSIG1RYO	
	P4_6	—	—	ADCA0CNV1	ESO2/ INTP8	
	P4_7	NMI	—	ADCA0CNV0	INTP9	
P5	P5_0	—	—	URTH0RXD/ INTP0	—	<ul style="list-style-type: none"> Input/output port Inputs and outputs are specifiable in 1-bit units.
	P5_1	—	—	URTH0TXD	ADCA0TRG0/ INTP3	
	P5_2	—	INTP2	URTH0SC	ADCA0TRG1/ INTP4	
	P5_3	—	ADCA0TRG0/ INTP3	URTH0CTS	ADCA0TRG2/ INTP5	
P8	P8_0	—	TAUB0O15	OSTM1O	—	<ul style="list-style-type: none"> Input/output port Inputs and outputs are specifiable in 1-bit units. TGLOUT output
JP0*1	JP0_1	—	—	—	—	<ul style="list-style-type: none"> JTAG port Used for the JTAG interface
	JP0_2	—	—	—	—	
	JP0_3	—	—	—	—	
	JP0_5	—	—	—	—	

Note 1. It is alternative with Nexus interface. When OPBT0.FOP31=0, JTAG ports are enabled. When OPBT0.FOP31=1, Nexus interface is enabled.

(2) List of Pins Other than Port Pins**Table 2-27 List of Pins Other than Port Pins (1/6)**

	Pin Name	Function
INTC	NMI	Input for non-maskable external interrupt requests
	INTP0	Input for maskable external interrupt requests
	INTP1	
	INTP2	
	INTP3	
	INTP4	
	INTP5	
	INTP6	
	INTP7	
	INTP8	
	INTP9	

Table 2-27 List of Pins Other than Port Pins (2/6)

	Pin Name	Function	
TAUB0	TAUB0I0	Input for the TAUB0 channel	
	TAUB0I1		
	TAUB0I2		
	TAUB0I3		
	TAUB0I4		
	TAUB0I5		
	TAUB0I6		
	TAUB0I7		
	TAUB0I8		
	TAUB0I9		
	TAUB0I10		
	TAUB0I11		
	TAUB0I12		
	TAUB0I13		
	TAUB0I14		
	TAUB0I15		
		TAUB0O0	Output for the TAUB0 channel
	TAUB0O1		
	TAUB0O2		
	TAUB0O3		
	TAUB0O4		
	TAUB0O5		
	TAUB0O6		
	TAUB0O7		
	TAUB0O8		
	TAUB0O9		
	TAUB0O10		
	TAUB0O11		
	TAUB0O12		
	TAUB0O13		
TAUB0O14			
TAUB0O15			

Table 2-27 List of Pins Other than Port Pins (3/6)

	Pin Name	Function
TAUJ0	TAUJ0I0	Input for the TAUJ0 channel
	TAUJ0I1	
	TAUJ0I2	
	TAUJ0I3	
	TAUJ0O0	Output for the TAUJ0 channel
	TAUJ0O1	
	TAUJ0O2	
	TAUJ0O3	
TSG20	TSG20O1	Pulse output for the TSG20
	TSG20O2	
	TSG20O3	
	TSG20O4	
	TSG20O5	
	TSG20O6	
	TSG20O7	
	TSG20PTSI0	Pattern input for the TSG20
	TSG20PTSI1	
	TSG20PTSI2	
ENC0	ENCA0E0	Encoder input for the ENC0 encoder counter
	ENCA0E1	
	ENCA0EC	Clearing input for the ENC0 encoder counter
TPB0	TPB0O	Pulse output from the TPB0 timer pattern buffer
OST0	OSTM0O	Output for OS timer 0
OST1	OSTM1O	Output for OS timer 1
TAPA	ESO0	Input for forcibly stopping timer output
	ESO2	
BRG	CLKOUT	Clock output
CAN0	FCN0TX	Output for data transmission from CAN0
	FCN0RX	Input for data reception by CAN0
CAN1	FCN1TX	Output for data transmission from CAN1
	FCN1RX	Input for data reception by CAN1
UART0	URTH0TXD	Output for serial data transmission from UART0
	URTH0RXD	Input for serial data reception by UART0
	URTH0CTS	Input for hand-shake signal in UART0 transmission
	URTH0SC	Input or output for the UART0 serial clock

Table 2-27 List of Pins Other than Port Pins (4/6)

	Pin Name	Function
UART1	URTH1TXD	Output for serial data transmission from UART1
	URTH1RXD	Input for serial data reception by UART1
	URTH1CTS	Input for hand-shake signal in UART1 transmission
	URTH1RTS	Output for hand-shake signal in UART1 reception
	URTH1SC	Input or output for the UART1 serial clock
CSIG0	CSIG0SC	Input or output for the CSIG0 serial clock
	CSIG0SI	Input for serial data reception by CSIG0
	CSIG0SO	Output for serial data transmission from CSIG0
	CSIG0RYI	Input for serial ready/busy from CSIG0
	CSIG0RYO	Output for serial ready/busy from CSIG0
CSIG1	CSIG1SC	Input or output for the CSIG1 serial clock
	CSIG1SI	Input for serial data reception by CSIG1
	CSIG1SO	Output for serial data transmission from CSIG1
	CSIG1RYI	Input for serial ready/busy from CSIG1
	CSIG1RYO	Output for serial ready/busy from CSIG1

Table 2-27 List of Pins Other than Port Pins (5/6)

	Pin Name	Function
ADCA0	ADCA0I1	Analog inputs for the A/D converter
	ADCA0I2	
	ADCA0I3	
	ADCA0I4	
	ADCA0I5	
	ADCA0I6	
	ADCA0I7	
	ADCA0I8	
	ADCA0I9	
	ADCA0I10	
	ADCA0I11	
	ADCA0I12	
	ADCA0I13	
	ADCA0I14	
	ADCA0I15	
	ADCA0I16	
	ADCA0I17	
	ADCA0I18	
	ADCA0TRG0	External trigger inputs for the A/D converter
	ADCA0TRG1	
	ADCA0TRG2	
	ADCA0CNV0	Status outputs for the A/D converter
	ADCA0CNV1	
ADCA0CNV2		
AVDD0	Source of positive power supply for the A/D converter	
AVSS0	Ground potential for the A/D converter	
AVREF0P	Source of reference power supply for the A/D converter	
AVREF0M	Reference ground potential for the A/D converter	
SGA	ERROROUT	Output for error signal from the safety guardian
Nexus	DCUTCK*1	Input for the debugger clock
	DCUTDI	Input for debugger data
	DCUTDO*1	Output for debugger data
	DCUTMS*1	Input for debugger mode-selection signal
	DCUTRST	Input for debugger reset
	DCUTRDY*1	Output for debugger-ready signal

Table 2-27 List of Pins Other than Port Pins (6/6)

	Pin Name	Function
Other debugger	$\overline{\text{DCUEVTO}}$	Output for event-trigger signal
	$\overline{\text{RESETOUT}}$, $\overline{\text{RESETOUT}}$	Output for debugger reset
	LPDIO	Single-pin debugging input/output pin
RESET	$\overline{\text{RESET}}$	Input for system reset
CLOCK	X1	For connection of crystal for system clock oscillation
	X2	
MODE	FLMD0	Operating mode specifying pin/flash write control pin
	FLMD1	Operation mode specifying pin
POWER	OSCVDD	Source of positive power supply for the OSC
	OSCVSS	Ground potential for the OSC
	VDD	Source of positive power supply for the on-chip regulator
	VSS	Ground potential for the on-chip regulator
	EVDD	Source of positive power supply for the external pins, code flash and data flash
	EVSS	Ground potential for external pins, code flash and data flash
	REGC0	Pin for connection of the capacitor for the on-chip regulator
	REGC1	Pin for connection of the capacitor for the on-chip regulator

Note 1. It is alternative with JTAG ports. When OPBT0.FOP31=0, JTAG ports are enabled. When OPBT0.FOP31=1, Nexus interface is enabled.

(3) Handling of Unused Port Pins

Table 2-28 Handling of Unused Port Pins (1/3)

Port Group Name	Port Name	Alternative Mode 1	Alternative Mode 2	Alternative Mode 3	Alternative Mode 4	Input/Output Circuit Type	Handling of Unused Pins
P0	P0_0	ADCA0TRG2/ INTP5	—	—	URTH0RXD/ INTP0	Type5-W	Set the pins as inputs (PMn_m = 1) in port mode (PMCn_m = 0), and connect them to on-board pull-up resistors (PUn_m = 1). Pins shall be left open-circuit.
	P0_1	ADCA0TRG1/ INTP4	—	—	URTH0TXD		
	P0_2	ADCA0TRG0/ INTP3	—	—	URTH0SC		
	P0_3	CLKOUT	—	—	URTH0CTS		
P1	P1_0	NMI/ CLKOUT	OSTM10	—	TSG2007	Type5-W	Set the pins as inputs (PMn_m = 1) in port mode (PMCn_m = 0), and connect them to on-board pull-up resistors (PUn_m = 1). Pins shall be left open-circuit.
	P1_1	TAUJ0I0/ TAUJ0O0	—	—	TSG2001		
	P1_2	TAUJ0I1/ TAUJ0O1	—	—	TSG2002		
	P1_3	TAUJ0I2/ TAUJ0O2	—	—	TSG2003		
	P1_4	TAUJ0I3/ TAUJ0O3	—	—	TSG2004		
	P1_5	—	—	—	TSG2005		
	P1_6	—	—	—	TSG2006		
	P1_7	—	CSIG0SI	—	URTH0RXD/ TSG2007/ INTP0		
	P1_8	TPB00	CSIG0SO	—	URTH0TXD		
	P1_9	—	CSIG0SC	—	URTH0SC		
P2	P2_0	TAUB0I1/ TAUB0O1	TAUB0I0/ TAUB0O0	URTH1SC	CSIG0RYI	Type5-W	Set the pins as inputs (PMn_m = 1) in port mode (PMCn_m = 0), and connect them to on-board pull-up resistors (PUn_m = 1). Pins shall be left open-circuit.
	P2_1	TAUB0I3/ TAUB0O3	TAUB0I2/ TAUB0O2	—	CSIG1RYI		
	P2_2	TAUB0I5/ TAUB0O5	TAUB0I4/ TAUB0O4	TAUB0O10	—		
	P2_3	TAUB0I7/ TAUB0O7	TAUB0I6/ TAUB0O6	TAUB0O12	—		
	P2_4	TAUB0I9/ TAUB0O9	TAUB0I8/ TAUB0O8	TAUB0O14	—		
	P2_5	TAUB0I11/ TAUB0O11	TAUB0I10/ TAUB0O10	—	—		
	P2_6	TAUB0I13/ TAUB0O13	TAUB0I12/ TAUB0O12	—	—		
	P2_7	TAUB0I15/ TAUB0O15	TAUB0I14/ TAUB0O14	—	—		

Table 2-28 Handling of Unused Port Pins (2/3)

Port Group Name	Port Name	Alternative Mode 1	Alternative Mode 2	Alternative Mode 3	Alternative Mode 4	Input/Output Circuit Type	Handling of Unused Pins
P3	P3_0	—	—	URTH1RXD/ INTP1	—	Type5-W	Set the pins as inputs (PMn_m = 1) in port mode (PMcn_m = 0), and connect them to on-board pull-up resistors (PUn_m = 1). Pins shall be left open-circuit.
	P3_1	—	—	URTH1TXD	—		
	P3_2	—	—	CSIG1SI	—		
	P3_3	—	—	CSIG1SO	TPB00		
	P3_4	—	—	CSIG1SC	—		
	P3_5	—	—	—	INTP2/ FCN1TX		
	P3_6	—	—	—	FCN1RX		
P4	P4_0	URTH1RXD/ INTP1	—	FCN0TX	—	Type5-W	Set the pins as inputs (PMn_m = 1) in port mode (PMcn_m = 0), and connect them to on-board pull-up resistors (PUn_m = 1). Pins shall be left open-circuit.
	P4_1	URTH1TXD	TSG20PTSI0/ ENCA0E0	FCN0RX	—		
	P4_2	CSIG1SI	TSG20PTSI1/ ENCA0E1/ OSTM10	—	—		
	P4_3	CSIG1SO	TSG20PTSI2/ ENCA0EC/ OSTM00	URTH1CTS	—		
	P4_4	CSIG1SC	—	URTH1RTS	ESO0/ INTP6/ CSIG0RYO		
	P4_5	—	—	ADCA0CNV2	INTP7/ CSIG1RYO		
	P4_6	—	—	ADCA0CNV1	ESO2/ INTP8		
	P4_7	NMI	—	ADCA0CNV0	INTP9		
P5	P5_0	—	—	URTH0RXD/ INTP0	—	Type5-W	Set the pins as inputs (PMn_m = 1) in port mode (PMcn_m = 0), and connect them to on-board pull-up resistors (PUn_m = 1). Pins shall be left open-circuit.
	P5_1	—	—	URTH0TXD	ADCA0TRG0/ INTP3		
	P5_2	—	INTP2	URTH0SC	ADCA0TRG1/ INTP4		
	P5_3	—	ADCA0TRG0/ INTP3	URTH0CTS	ADCA0TRG2/ INTP5		
P8	P8_0	—	TAUB0015	OSTM10	—	Type5-W	Set the pins as inputs (PMn_m = 1) in port mode (PMcn_m = 0), and connect them to on-board pull-up resistors (PUn_m = 1). Pins shall be left open-circuit.

Table 2-28 Handling of Unused Port Pins (3/3)

Port Group Name	Port Name	Alternative Mode 1	Alternative Mode 2	Alternative Mode 3	Alternative Mode 4	Input/Output Circuit Type	Handling of Unused Pins
JP0* ¹	JP0_1					Type TDO	In input mode: Set the pins as inputs (JPM0_m = 1), and connect them to on-board pull-up resistors (JPU0_m = 1). Pins shall be left open-circuit.
	JP0_2					Type TCK	
	JP0_3					Type TMS	
	JP0_5					Type RDY	

Note 1. It is alternative with Nexus interface. When OPBT0.FOP31=0, JTAG ports are enabled. When OPBT0.FOP31=1, Nexus interface is enabled.

(4) Handling of Unused Pins Other than Port Pins

Table 2-29 Handling of Unused Pins Other than Port Pins (1/2)

Pin Name	Input/Output Circuit Type	Handling	
FLMD0	Type2-W	Must be used. Connect this pin to EVSS via a resistance no less than 270 kΩ.	
FLMD1	Type2-I	Must be used. Connect this pin to EVSS directly.	
$\overline{\text{RESET}}$	Type2-I	Must be used.	
$\overline{\text{DCUTRST}}$	Type2-X	Connect this pin to EVSS.	
DCUTCK ^{*1}	Type TCK	Leave.	
DCUTDI	Type LPDIO		
DCUTDO ^{*1}	Type TDO		
DCUTMS ^{*1}	Type TMS		
$\overline{\text{DCUTRDY}}^{\text{*1}}$	Type $\overline{\text{RDY}}$		
DCUEVTO	Type3		
ERROROUT	Type ERROROUT		Leave this pin.
X1	—		Must be used.
X2	—		
ADCA011	Type7	When the ADC is not in use: directly connect the pins to EVDD or EVSS. Unused channels when the ADC is in use: directly connect the pins to AVDD0 or AVSS0.	
ADCA012			
ADCA013			
ADCA014			
ADCA015			
ADCA016			
ADCA017			
ADCA018			
ADCA019			
ADCA0110			
ADCA0111			
ADCA0112			
ADCA0113			
ADCA0114			
ADCA0115			
ADCA0116			
ADCA0117			
ADCA0118			
AVREF0P	—	When the ADC is not in use: connect to EVDD.	
AVREF0M	—	When the ADC is not in use: connect to EVSS.	
AVDD0	—	When the ADC is not in use: connect to EVDD.	
AVSS0	—	When the ADC is not in use: connect to EVSS.	

Table 2-29 Handling of Unused Pins Other than Port Pins (2/2)

Pin Name	Input/Output Circuit Type	Handling
VDD	—	Must be used.
VSS	—	
OSCVDD	—	
OSCVSS	—	
EVDD	—	
EVSS	—	
REGC0	—	
REGC1	—	

Note 1. It is alternative with JTAG ports. When OPBT0.FOP31=0, JTAG ports are enabled. When OPBT0.FOP31=1, Nexus interface is enabled.

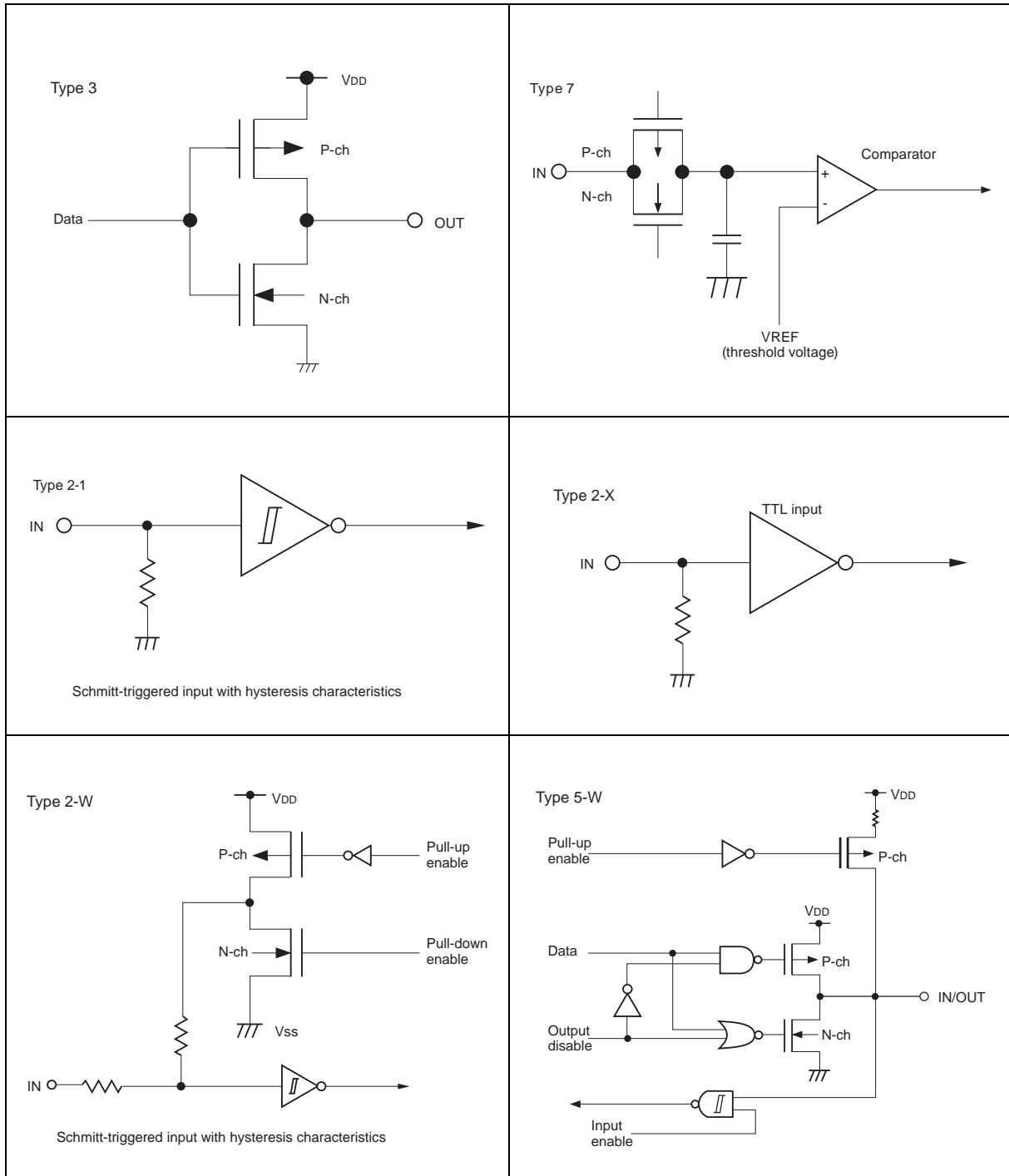

Figure 2-2 I/O circuit type(1/2)

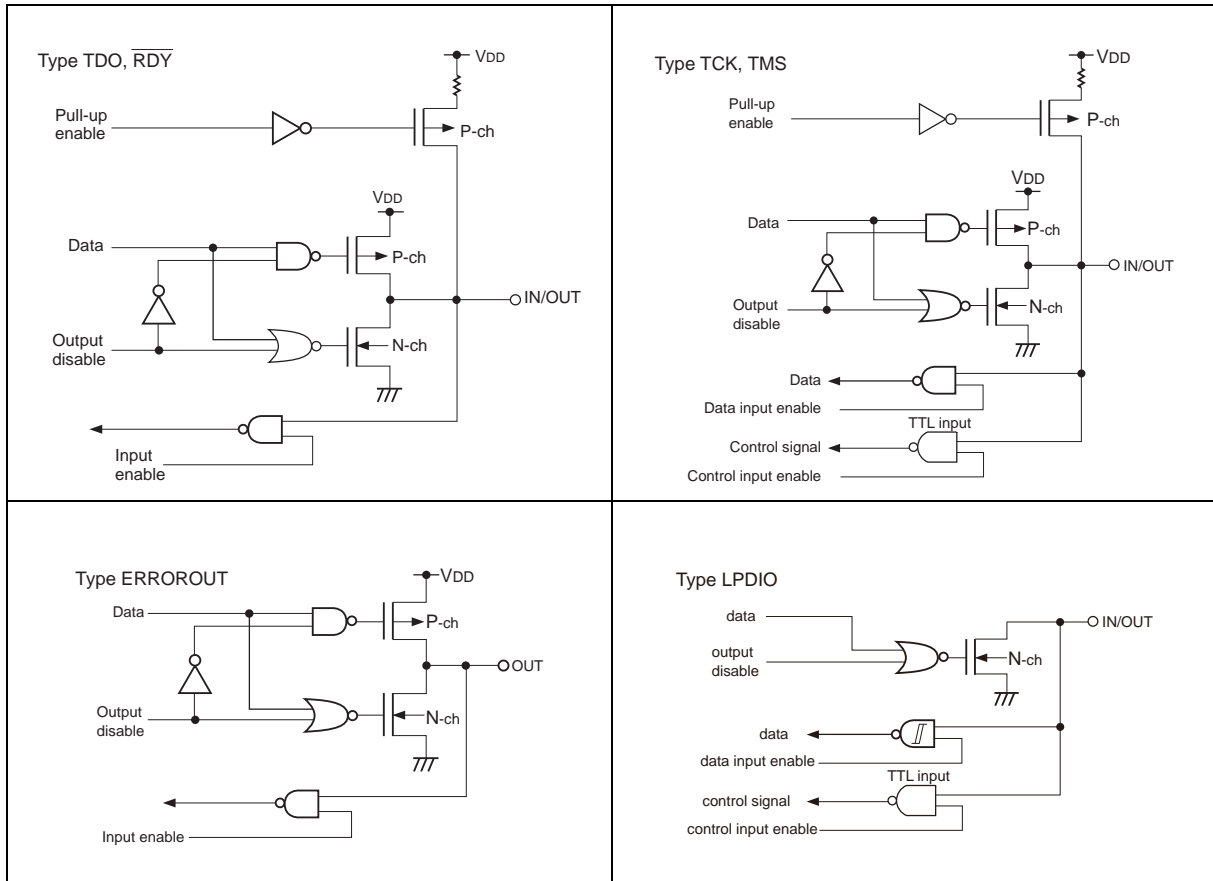

Figure 2-2 I/O circuit type(2/2)

(5) States of Port Pins

Table 2-30 List of States of Port Pins (1/2)

Port Group Name	Pin Name	Alter-native Mode 1	Alter-native Mode 2	Alter-native Mode 3	Alter-native Mode 4	Reset	BIST for Self-diagnosis is Running	Immediately after Releasing the CPU Core from Reset	HALT Mode
P0	P0_0	ADCA0TRG2/ INTP5	—	—	URTH0RXD/ INTP0	Hi-Z	Hi-Z	Hi-Z	Port output: Retained Port input: Non- sampling Alternative output: can operate Alternative input: can operate
	P0_1	ADCA0TRG1/ INTP4	—	—	URTH0TXD				
	P0_2	ADCA0TRG0/ INTP3	—	—	URTH0SC				
	P0_3	CLKOUT	—	—	URTH0CTS				
P1	P1_0	NMI/ CLKOUT	OSTM1O	—	TSG2007	Hi-Z	Hi-Z	Hi-Z	Port output: Retained Port input: Non- sampling Alternative output: can operate Alternative input: can operate
	P1_1	TAUJ0I0/ TAUJ0O0	—	—	TSG2001				
	P1_2	TAUJ0I1/ TAUJ0O1	—	—	TSG2002				
	P1_3	TAUJ0I2/ TAUJ0O2	—	—	TSG2003				
	P1_4	TAUJ0I3/ TAUJ0O3	—	—	TSG2004				
	P1_5	—	—	—	TSG2005				
	P1_6	—	—	—	TSG2006				
	P1_7	—	CSIG0SI	—	URTH0RXD/ TSG2007/ INTP0				
	P1_8	TPB00	CSIG0SO	—	URTH0TXD				
	P1_9	—	CSIG0SC	—	URTH0SC				
P2	P2_0	TAUB0I1/ TAUB0O1	TAUB0I0/ TAUB0O0	URTH1SC	CSIG0RYI	Hi-Z	Hi-Z	Hi-Z	Port output: Retained Port input: Non- sampling Alternative output: can operate Alternative input: can operate
	P2_1	TAUB0I3/ TAUB0O3	TAUB0I2/ TAUB0O2	—	CSIG1RYI				
	P2_2	TAUB0I5/ TAUB0O5	TAUB0I4/ TAUB0O4	TAUB0O10	—				
	P2_3	TAUB0I7/ TAUB0O7	TAUB0I6/ TAUB0O6	TAUB0O12	—				
	P2_4	TAUB0I9/ TAUB0O9	TAUB0I8/ TAUB0O8	TAUB0O14	—				
	P2_5	TAUB0I11/ TAUB0O11	TAUB0I10/ TAUB0O10	—	—				
	P2_6	TAUB0I13/ TAUB0O13	TAUB0I12/ TAUB0O12	—	—				
	P2_7	TAUB0I15/ TAUB0O15	TAUB0I14/ TAUB0O14	—	—				
P3	P3_0	—	—	URTH1RXD/ INTP1	—	Hi-Z	Hi-Z	Hi-Z	Port output: Retained Port input: Non- sampling Alternative output: can operate Alternative input: can operate
	P3_1	—	—	URTH1TXD	—				
	P3_2	—	—	CSIG1SI	—				
	P3_3	—	—	CSIG1SO	TPB00				
	P3_4	—	—	CSIG1SC	—				
	P3_5	—	—	—	INTP2/ FCN1TX				
	P3_6	—	—	—	FCN1RX				

Table 2-30 List of States of Port Pins (2/2)

Port Group Name	Pin Name	Alter-native Mode 1	Alter-native Mode 2	Alter-native Mode 3	Alter-native Mode 4	Reset	BIST for Self-diagnosis is Running	Immediately after Releasing the CPU Core from Reset	HALT Mode
P4	P4_0	URTH1RXD/ INTP1	—	FCN0TX	—	Hi-Z	Hi-Z	Hi-Z	Port output: Retained Port input: Non- sampling Alternative output: can operate Alternative input: can operate
	P4_1	URTH1TXD	TSG20PTS10/ ENCA0E0	FCN0RX	—				
	P4_2	CSIG1SI	TSG20PTS11/ ENCA0E1/ OSTM1O	—	—				
	P4_3	CSIG1SO	TSG20PTS12/ ENCA0EC/ OSTM0O	URTH1CTS	—				
	P4_4	CSIG1SC	—	URTH1RTS	ESO0/ INTP6/ CSIG0RYO				
	P4_5	—	—	ADCA0CNV2	INTP7/ CSIG1RYO				
	P4_6	—	—	ADCA0CNV1	ESO2/ INTP8				
	P4_7	NMI	—	ADCA0CNV0	INTP9				
P5	P5_0	—	—	URTH0RXD/ INTP0	—	Hi-Z	Hi-Z	Hi-Z	Port output: Retained Port input: Non- sampling Alternative output: can operate Alternative input: can operate
	P5_1	—	—	URTH0TXD	ADCA0TRG0/ INTP3				
	P5_2	—	INTP2	URTH0SC	ADCA0TRG1/ INTP4				
	P5_3	—	ADCA0TRG0/ INTP3	URTH0CTS	ADCA0TRG2/ INTP5				
P8	P8_0	—	TAUB0O15	OSTM1O	—	Hi-Z	Hi-Z	Hi-Z	Port output: Retained Port input: Non- sampling Alternative output: can operate Alternative input: can operate
JP0*1	JP0_1	—	—	—	—	Hi-Z	Hi-Z	Hi-Z	Port output: Retained Port input: Non- sampling
	JP0_2	—	—	—	—	Hi-Z	Hi-Z	Hi-Z	
	JP0_3	—	—	—	—	Hi-Z	Hi-Z	Hi-Z	
	JP0_5	—	—	—	—	Hi-Z	Hi-Z	Hi-Z	

Note 1. It is alternative with Nexus interface. When PBT0.FOP31=0, JTAG ports are enabled. When OPBT0.FOP31=1, Nexus interface is enabled.

(6) States of Pins Other than Port Pins

Table 2-31 List of States of Pins Other than Port Pins (1/2)

Pin Name	Reset	BIST for Self-diagnosis is Running	Immediately after Releasing the CPU Core from Reset	Halt Mode
FLMD0	—	—	—	—
FLMD1	—	—	—	—
RESET	Low	High	High	High
DCUTRST	*1	*1	Operation	Operation
DCUEVTO	Low	Low	Operation*2	Operation*2
DCUTDI	Hi-Z	Hi-Z	Operation*4,*5	Operation*4
DCUTDO*6	Hi-Z	Hi-Z	Operation*4,*5	Operation*4
DCUTCK*6	Hi-Z	Hi-Z	Operation*4,*5	Operation*4
DCUTMS*6	Hi-Z	Hi-Z	Operation*4,*5	Operation*4
DCUTRDY*6	Hi-Z	Hi-Z	Operation*4,*5	Operation*4
ERROROUT*3	Hi-Z	Low	Low	Operable
X1	Operation	Operation	Operation	Operation
X2	Operation	Operation	Operation	Operation

Note 1. For input of the high level to DCUTRST, confirm that the low level is being output from DCUTRDY and execute the Nexus start-up sequence beforehand. See Section 25.3 Notes on On-Chip Debugging.

Note 2. The output on DCUEVTO is at the low level while the internal reset signal (CPURES) is at the low level. If DCUTRST is set to the high level, this becomes the output from DCUEVTO.

Note 3. ERROROUT pin is Hi-Z during an external reset and at the low level. However, the ERROROUT pin is also at the low level during an external reset in debugging mode.

Note 4. When DCUTRST = L, this is Hi-Z.

Note 5. With development tools (RAM monitor and the like), set DCUTRST to the high level after DCUTRDY = L.

Note 6. It is alternative with JTAG ports. When OPBT0.FOP31=0, JTAG ports are enabled. When OPBT0.FOP31=1, Nexus interface is enabled.

Table 2-31 List of States of Pins Other than Port Pins (2/2)

Pin Name	Reset	BIST for Self-diagnosis is Running	Immediately after Releasing the CPU Core from Reset	Halt Mode
ADCA011	—	—	Operable	Operable
ADCA012				
ADCA013				
ADCA014				
ADCA015				
ADCA016				
ADCA017				
ADCA018				
ADCA019				
ADCA0110				
ADCA0111				
ADCA0112				
ADCA0113				
ADCA0114				
ADCA0115				
ADCA0116				
ADCA0117				
ADCA0118				
AVREF0P	—	—	—	—
AVREF0M				
AVDD0				
AVSS0				
VDD				
VSS				
OSCVDD				
OSCVSS				
EVDD				
EVSS				
REGC0	—	—	—	—
REGC1				

(7) Pin States under Specified Conditions

1. Port pins are in the Hi-Z state during an external reset in on-chip debugging mode.
Self-diagnosis BIST is not executed after release from an external reset in on-chip debugging mode.
2. Pin states in flash memory programming mode are identical to those in single chip mode.
Self-diagnosis BIST is not executed in flash memory programming mode.

2.5 Functions of Pull-Up and Pull-Down Resistors

This section describes target pins for pull-up and pull-down resistors.

2.5.1 Details of Pull-Up and Pull-Down Resistors

(1) Pull-Up and Pull-Down Resistors for Port Pins

Table 2-32 List of Pull-Up and Pull-Down Resistors for Port Pins (1/3)

Port Group Name	Port Name	Alternative Mode 1	Alternative Mode 2	Alternative Mode 3	Alternative Mode 4	Pull-Up Resistor, Pull-Down Resistor
P0	P0_0	ADCA0TRG2/ INTP5	—	—	URTH0RXD/ INTP0	Software pull-up (initial value: off)
	P0_1	ADCA0TRG1/ INTP4	—	—	URTH0TXD	
	P0_2	ADCA0TRG0/ INTP3	—	—	URTH0SC	
	P0_3	CLKOUT	—	—	URTH0CTS	
P1	P1_0	NMI/ CLKOUT	OSTM1O	—	TSG2007	Software pull-up (initial value: off)
	P1_1	TAUJ0I0/ TAUJ0O0	—	—	TSG2001	
	P1_2	TAUJ0I1/ TAUJ0O1	—	—	TSG2002	
	P1_3	TAUJ0I2/ TAUJ0O2	—	—	TSG2003	
	P1_4	TAUJ0I3/ TAUJ0O3	—	—	TSG2004	
	P1_5	—	—	—	TSG2005	
	P1_6	—	—	—	TSG2006	
	P1_7	—	CSIG0SI	—	URTH0RXD/ TSG2007/ INTP0	
	P1_8	TPB0O	CSIG0SO	—	URTH0TXD	
	P1_9	—	CSIG0SC	—	URTH0SC	

Table 2-32 List of Pull-Up and Pull-Down Resistors for Port Pins (2/3)

Port Group Name	Port Name	Alternative Mode 1	Alternative Mode 2	Alternative Mode 3	Alternative Mode 4	Pull-Up Resistor, Pull-Down Resistor
P2	P2_0	TAUB0I1/ TAUB0O1	TAUB0I0/ TAUB0O0	URTH1SC	CSIG0RYI	Software pull-up (initial value: off)
	P2_1	TAUB0I3/ TAUB0O3	TAUB0I2/ TAUB0O2	—	CSIG1RYI	
	P2_2	TAUB0I5/ TAUB0O5	TAUB0I4/ TAUB0O4	TAUB0O10	—	
	P2_3	TAUB0I7/ TAUB0O7	TAUB0I6/ TAUB0O6	TAUB0O12	—	
	P2_4	TAUB0I9/ TAUB0O9	TAUB0I8/ TAUB0O8	TAUB0O14	—	
	P2_5	TAUB0I11/ TAUB0O11	TAUB0I10/ TAUB0O10	—	—	
	P2_6	TAUB0I13/ TAUB0O13	TAUB0I12/ TAUB0O12	—	—	
	P2_7	TAUB0I15/ TAUB0O15	TAUB0I14/ TAUB0O14	—	—	
P3	P3_0	—	—	URTH1RXD/ INTP1	—	Software pull-up (initial value: off)
	P3_1	—	—	URTH1TXD	—	
	P3_2	—	—	CSIG1SI	—	
	P3_3	—	—	CSIG1SO	TPB00	
	P3_4	—	—	CSIG1SC	—	
	P3_5	—	—	—	INTP2/ FCN1TX	
	P3_6	—	—	—	FCN1RX/	
P4	P4_0	URTH1RXD/ INTP1	—	FCN0TX	—	Software pull-up (initial value: off)
	P4_1	URTH1TXD	TSG20PTSI0/ ENCA0E0	FCN0RX	—	
	P4_2	CSIG1SI	TSG20PTSI1/ ENCA0E1/ OSTM1O	—	—	
	P4_3	CSIG1SO	TSG20PTSI2/ ENCA0EC/ OSTM0O	URTH1CTS	—	
	P4_4	CSIG1SC	—	URTH1RTS	ESO0/ INTP6/ CSIG0RYO	
	P4_5	—	—	ADCA0CNV2	INTP7/ CSIG1RYO	
	P4_6	—	—	ADCA0CNV1	ESO2/ INTP8	
	P4_7	NMI	—	ADCA0CNV0	INTP9	

Table 2-32 List of Pull-Up and Pull-Down Resistors for Port Pins (3/3)

Port Group Name	Port Name	Alternative Mode 1	Alternative Mode 2	Alternative Mode 3	Alternative Mode 4	Pull-Up Resistor, Pull-Down Resistor
P5	P5_0	—	—	URTH0RXD/ INTP0	—	Software pull-up (initial value: off)
	P5_1	—	—	URTH0TXD	ADCA0TRG0/ INTP3	
	P5_2	—	INTP2	URTH0SC	ADCA0TRG1/ INTP4	
	P5_3	—	ADCA0TRG0/ INTP3	URTH0CTS	ADCA0TRG2/ INTP5	
P8	P8_0	—	TAUB0015	OSTM10	—	Software pull-up (initial value: off)
JP0	JP_1	—	—	—	—	Software pull-up (initial value: off)
	JP_2	—	—	—	—	Software pull-up (initial value: off)
	JP_3	—	—	—	—	Software pull-up (initial value: off)
	JP_5	—	—	—	—	Software pull-up (initial value: off)

(2) Pull-Up and Pull-Down Resistors for Pins Other than Port Pins

Table 2-33 List of Pull-Up and Pull-Down Resistors for Pins Other than Port Pins (1/2)

Pin Name	Pull-Up Resistor, Pull Down Resistor
FLMD0	Software pull-up/pull-down (initial value: pull-down on)
FLMD1	Always pull-down
$\overline{\text{RESET}}$	Always pull-down
$\overline{\text{DCUTRST}}$	Always pull-down
$\overline{\text{DCUEVTO}}$	—
DCUTDI	—
DCUTDO	Connected to the on-chip pull-up resistor However, not connected to the pull-up resistor during DCUTDO output.
DCUTCK	Connected to the on-chip pull-up resistor
DCUTMS	Connected to the on-chip pull-up resistor
$\overline{\text{DCUTRDY}}$	—
ERROROUT	—
X1	—
X2	—

Table 2-33 List of Pull-Up and Pull-Down Resistors for Pins Other than Port Pins (2/2)

Pin Name	Pull-Up Resistor, Pull Down Resistor
ADCA011	Software pull-down (initial value: off)
ADCA012	
ADCA013	
ADCA014	
ADCA015	
ADCA016	
ADCA017	
ADCA018	
ADCA019	
ADCA0110	
ADCA0111	
ADCA0112	
ADCA0113	
ADCA0114	
ADCA0115	
ADCA0116	
ADCA0117	
ADCA0118	
AVREF0P	—
AVREF0M	—
AVDD0	—
AVSS0	—
VDD	—
VSS	
OSCVDD	
OSCVSS	
EVDD	
EVSS	
REGC0	
REGC1	

2.6 Port 0

This section describes alternative functions and control registers of port 0.

2.6.1 Alternative Functions

(1) Alternative Functions of Port 0

Table 2-34 List of Alternative Functions of Port 0

Port Mode (PMC = 0)	Control Mode (PMC = 1)							
	Alternative Mode 1 (PFC = 0, PFCE = 0)		Alternative Mode 2 (PFC=1, PFCE=0)		Alternative Mode 3 (PFC = 0, PFCE = 1)		Alternative Mode 4 (PFC = 1, PFCE = 1)	
	Input (PM = 1)	Output (PM = 0)	Input (PM = 1)	Output (PM = 0)	Input (PM = 1)	Output (PM = 0)	Input (PM = 1)	Output (PM = 0)
P0_0	INTP5/ ADCA0 TRG2	—	—	—	—	—	URTH0 RXD/ INTP0	—
P0_1	INTP4/ ADCA0 TRG1	—	—	—	—	—	—	URTH0 TXD
P0_2	INTP3/ ADCA0 TRG0	—	—	—	—	—	URTH0SC	URTH0SC
P0_3	—	CLKOUT	—	—	—	—	URTH0 CTS	—

2.6.2 List of Control Registers

(1) Port 0 Control Registers

Table 2-35 List of Port 0 Control Registers

Name	Number of Bits			15	14	13	12	11	10	9	8	7	6	5	4	3	2	1	0	
	8	16	32																	
P0	—	√	—	—	—	—	—	—	—	—	—	—	—	—	—	√	√	√	√	
PSR0	—	—	√	—	—	—	—	—	—	—	—	—	—	—	—	—	√	√	√	√
				—	—	—	—	—	—	—	—	—	—	—	—	—	—	—	√	√
PPR0	—	√	—	—	—	—	—	—	—	—	—	—	—	—	—	—	√	√	√	√
PM0	—	√	—	—	—	—	—	—	—	—	—	—	—	—	—	—	√	√	√	√
PMC0	—	√	—	—	—	—	—	—	—	—	—	—	—	—	—	—	√	√	√	√
PFC0	—	√	—	—	—	—	—	—	—	—	—	—	—	—	—	—	√	√	√	√
PFCE0	—	√	—	—	—	—	—	—	—	—	—	—	—	—	—	—	√	√	√	√
PNOT0	—	√	—	—	—	—	—	—	—	—	—	—	—	—	—	—	√	√	√	√
PMSR0	—	—	√	—	—	—	—	—	—	—	—	—	—	—	—	—	√	√	√	√
				—	—	—	—	—	—	—	—	—	—	—	—	—	—	—	√	√
PMCSR0	—	—	√	—	—	—	—	—	—	—	—	—	—	—	—	—	√	√	√	√
				—	—	—	—	—	—	—	—	—	—	—	—	—	—	—	√	√
PIBC0	—	√	—	—	—	—	—	—	—	—	—	—	—	—	—	—	√	√	√	√
PBDC0	—	√	—	—	—	—	—	—	—	—	—	—	—	—	—	—	√	√	√	—
PIPC0	—	√	—	—	—	—	—	—	—	—	—	—	—	—	—	—	—	√	—	—
PU0	—	√	—	—	—	—	—	—	—	—	—	—	—	—	—	—	√	√	√	√

2.7 Port 1

This section describes alternative functions and control registers of port 1.

2.7.1 Alternative Functions

(1) Alternative Functions of Port 1

Table 2-36 List of Alternative Functions of Port 1

Port Mode (PMC = 0)	Control Mode (PMC = 1)							
	Alternative Mode 1 (PFC = 0, PFCE = 0)		Alternative Mode 2 (PFC = 1, PFCE = 0)		Alternative Mode 3 (PFC = 0, PFCE = 1)		Alternative Mode 4 (PFC = 1, PFCE = 1)	
	Input (PM = 1)	Output (PM = 0)	Input (PM = 1)	Output (PM = 0)	Input (PM = 1)	Output (PM = 0)	Input (PM = 1)	Output (PM = 0)
P1_0	NMI	CLKOUT	—	OSTM10	—	—	—	TSG2007
P1_1	TAUJ0I0	TAUJ0O0	—	—	—	—	—	TSG2001
P1_2	TAUJ0I1	TAUJ0O1	—	—	—	—	—	TSG2002
P1_3	TAUJ0I2	TAUJ0O2	—	—	—	—	—	TSG2003
P1_4	TAUJ0I3	TAUJ0O3	—	—	—	—	—	TSG2004
P1_5	—	—	—	—	—	—	—	TSG2005
P1_6	—	—	—	—	—	—	—	TSG2006
P1_7	—	—	CSIG0SI	—	—	—	URTH0 RXD/ INTP0	TSG2007
P1_8	—	TPB00	CSIG0SO *1	CSIG0SO	—	—	—	URTH0 TXD
P1_9	—	—	CSIG0SC	CSIG0SC	—	—	URTH0SC	URTH0SC

Note 1. Corresponds to data consistency checking.

2.7.2 List of Control Registers

(1) Port 1 Control Registers

Table 2-37 List of Port 1 Control Registers

Name	Number of Bits			15	14	13	12	11	10	9	8	7	6	5	4	3	2	1	0
	8	16	32																
P1	—	√	—	—	—	—	—	—	—	√	√	√	√	√	√	√	√	√	√
PSR1	—	—	√	—	—	—	—	—	—	√	√	√	√	√	√	√	√	√	√
				—	—	—	—	—	—	—	—	√	√	√	√	√	√	√	√
PPR1	—	√	—	—	—	—	—	—	—	√	√	√	√	√	√	√	√	√	√
PM1	—	√	—	—	—	—	—	—	—	√	√	√	√	√	√	√	√	√	√
PMC1	—	√	—	—	—	—	—	—	—	√	√	√	√	√	√	√	√	√	√
PFC1	—	√	—	—	—	—	—	—	—	√	√	√	√	√	√	√	√	√	√
PFCE1	—	√	—	—	—	—	—	—	—	√	√	√	√	√	√	√	√	√	√
PNOT1	—	√	—	—	—	—	—	—	—	√	√	√	√	√	√	√	√	√	√
PMSR1	—	—	√	—	—	—	—	—	—	√	√	√	√	√	√	√	√	√	√
				—	—	—	—	—	—	—	—	√	√	√	√	√	√	√	√
PMCSR1	—	—	√	—	—	—	—	—	—	√	√	√	√	√	√	√	√	√	√
				—	—	—	—	—	—	—	—	√	√	√	√	√	√	√	√
PIBC1	—	√	—	—	—	—	—	—	—	√	√	√	√	√	√	√	√	√	√
PBDC1	—	√	—	—	—	—	—	—	—	√	√	√	√	√	√	√	√	√	√
PIPC1	—	√	—	—	—	—	—	—	—	√	—	—	√	√	√	√	√	√	—
PU1	—	√	—	—	—	—	—	—	—	√	√	√	√	√	√	√	√	√	√

2.8 Port 2

This section describes alternative functions and control registers of port 2.

2.8.1 Alternative Functions

(1) Alternative Functions of Port 2

Table 2-38 List of Alternative Functions of Port 2

Port Mode (PMC = 0)	Control Mode (PMC = 1)							
	Alternative Mode 1 (PFC = 0, PFCE = 0)		Alternative Mode 2 (PFC = 1, PFCE = 0)		Alternative Mode 3 (PFC = 0, PFCE = 1)		Alternative Mode 4 (PFC = 1, PFCE = 1)	
	Input (PM = 1)	Output (PM = 0)	Input (PM = 1)	Output (PM = 0)	Input (PM = 1)	Output (PM = 0)	Input (PM = 1)	Output (PM = 0)
P2_0	TAUB0I1	TAUB0O1	TAUB0I0	TAUB0O0	URTH1SC	URTH1SC	CSIG0RYI	—
P2_1	TAUB0I3	TAUB0O3	TAUB0I2	TAUB0O2	—	—	CSIG1RYI	—
P2_2	TAUB0I5	TAUB0O5	TAUB0I4	TAUB0O4	—	TAUB0O10	—	—
P2_3	TAUB0I7	TAUB0O7	TAUB0I6	TAUB0O6	—	TAUB0O12	—	—
P2_4	TAUB0I9	TAUB0O9	TAUB0I8	TAUB0O8	—	TAUB0O14	—	—
P2_5	TAUB0I11	TAUB0O11	TAUB0I10	TAUB0O10	—	—	—	—
P2_6	TAUB0I13	TAUB0O13	TAUB0I12	TAUB0O12	—	—	—	—
P2_7	TAUB0I15	TAUB0O15	TAUB0I14	TAUB0O14	—	—	—	—

2.8.2 List of Control Registers

(1) Port 2 Control Register

Table 2-39 List of Port 2 Control Registers

Name	Number of Bits			15	14	13	12	11	10	9	8	7	6	5	4	3	2	1	0
	8	16	32																
P2	—	√	—	—	—	—	—	—	—	—	—	√	√	√	√	√	√	√	√
PSR2	—	—	√	—	—	—	—	—	—	—	—	√	√	√	√	√	√	√	√
				—	—	—	—	—	—	—	—	—	—	√	√	√	√	√	√
PPR2	—	√	—	—	—	—	—	—	—	—	—	√	√	√	√	√	√	√	√
PM2	—	√	—	—	—	—	—	—	—	—	—	√	√	√	√	√	√	√	√
PMC2	—	√	—	—	—	—	—	—	—	—	—	√	√	√	√	√	√	√	√
PFC2	—	√	—	—	—	—	—	—	—	—	—	√	√	√	√	√	√	√	√
PFCE2	—	√	—	—	—	—	—	—	—	—	—	—	—	—	√	√	√	√	√
PNOT2	—	√	—	—	—	—	—	—	—	—	—	√	√	√	√	√	√	√	√
PMSR2	—	—	√	—	—	—	—	—	—	—	—	√	√	√	√	√	√	√	√
				—	—	—	—	—	—	—	—	—	—	√	√	√	√	√	√
PMCSR2	—	—	√	—	—	—	—	—	—	—	—	√	√	√	√	√	√	√	√
				—	—	—	—	—	—	—	—	—	—	√	√	√	√	√	√
PIBC2	—	√	—	—	—	—	—	—	—	—	—	√	√	√	√	√	√	√	√
PBDC2	—	√	—	—	—	—	—	—	—	—	—	√	√	√	√	√	√	√	√
PIPC2	—	√	—	—	—	—	—	—	—	—	—	√	√	√	√	√	√	—	√
PU2	—	√	—	—	—	—	—	—	—	—	—	√	√	√	√	√	√	√	√
PODC2	—	—	√	—	—	—	—	—	—	—	—	√	√	√	√	√	√	√	√
				—	—	—	—	—	—	—	—	—	—	—	—	—	—	—	—
PPROTS2	√	—	—	—	—	—	—	—	—	—	—	—	—	—	—	—	—	—	√
PPCMD2	√	—	—	—	—	—	—	—	—	—	—	√	√	√	√	√	√	√	√

2.9 Port 3

This section describes alternative functions and control registers of port 3.

2.9.1 Alternative Functions

(1) Port 3 Control Registers

Table 2-40 List of Alternative Functions of Port 3

Port Mode (PMC = 0)	Control Mode (PMC = 1)							
	Alternative Mode 1 (PFC = 0, PFCE = 0)		Alternative Mode 2 (PFC = 1, PFCE = 0)		Alternative Mode 3 (PFC = 0, PFCE = 1)		Alternative Mode 4 (PFC = 1, PFCE = 1)	
	Input (PM = 1)	Output (PM = 0)	Input (PM = 1)	Output (PM = 0)	Input (PM = 1)	Output (PM = 0)	Input (PM = 1)	Output (PM = 0)
P3_0	—	—	—	—	URTH1RXD /INTP1	—	—	—
P3_1	—	—	—	—	—	URTH1 TXD	—	—
P3_2	—	—	—	—	CSIG1SI	—	—	—
P3_3	—	—	—	—	CSIG1SO *1	CSIG1SO	—	TPB00
P3_4	—	—	—	—	CSIG1SC	CSIG1SC	—	—
P3_5	—	—	—	—	—	—	INTP2	FCN1TX
P3_6	—	—	—	—	—	—	FCN1RX	—

Note 1. Corresponds to data consistency checking.

2.9.2 List of Control Registers

(1) List of Port 3 Control Registers

Table 2-41 List of Port 3 Control Registers

Name	Number of Bits			15	14	13	12	11	10	9	8	7	6	5	4	3	2	1	0
	8	16	32																
P3	—	√	—	—	—	—	—	—	—	—	—	—	√	√	√	√	√	√	√
PSR3	—	—	√	—	—	—	—	—	—	—	—	—	√	√	√	√	√	√	√
				—	—	—	—	—	—	—	—	—	—	—	√	√	√	√	√
PPR3	—	√	—	—	—	—	—	—	—	—	—	—	√	√	√	√	√	√	√
PM3	—	√	—	—	—	—	—	—	—	—	—	—	√	√	√	√	√	√	√
PMC3	—	√	—	—	—	—	—	—	—	—	—	—	√	√	√	√	√	√	√
PFC3	—	√	—	—	—	—	—	—	—	—	—	—	√	√	√	√	√	√	√
PFCE3	—	√	—	—	—	—	—	—	—	—	—	—	√	√	√	√	√	√	√
PNOT3	—	√	—	—	—	—	—	—	—	—	—	—	√	√	√	√	√	√	√
PMSR3	—	—	√	—	—	—	—	—	—	—	—	—	√	√	√	√	√	√	√
				—	—	—	—	—	—	—	—	—	—	—	√	√	√	√	√
PMCSR3	—	—	√	—	—	—	—	—	—	—	—	—	√	√	√	√	√	√	√
				—	—	—	—	—	—	—	—	—	—	—	√	√	√	√	√
PIBC3	—	√	—	—	—	—	—	—	—	—	—	—	√	√	√	√	√	√	√
PBDC3	—	√	—	—	—	—	—	—	—	—	—	—	—	√	√	√	—	√	—
PIPC3	—	√	—	—	—	—	—	—	—	—	—	—	—	—	√	—	—	—	—
PU3	—	√	—	—	—	—	—	—	—	—	—	—	√	√	√	√	√	√	√

2.10 Port 4

This section describes alternative functions and control registers of port 4.

2.10.1 Alternative Functions

(1) Alternative Functions of Port 4

Table 2-42 List of Alternative Functions of Port 4

Port Mode (PMC = 0)	Control Mode (PMC = 1)							
	Alternative Mode 1 (PFC = 0, PFCE = 0)		Alternative Mode 2 (PFC = 1, PFCE = 0)		Alternative Mode 3 (PFC = 0, PFCE = 1)		Alternative Mode 4 (PFC = 1, PFCE = 1)	
	Input (PM = 1)	Output (PM = 0)	Input (PM = 1)	Output (PM = 0)	Input (PM = 1)	Output (PM = 0)	Input (PM = 1)	Output (PM = 0)
P4_0	URTH1 RXD/ INTP1	—	—	—	—	FCN0TX	—	—
P4_1	—	URTH1 TXD	TSG20 PTSI0/ ENCA0E0	—	FCN0RX	—	—	—
P4_2	CSIG1SI	—	TSG20 PTSI1/ ENCA0E1	OSTM1O	—	—	—	—
P4_3	CSIG1SO *1	CSIG1SO	TSG20 PTSI2/ ENCA0EC	OSTM0O	URTH1 CTS	—	—	—
P4_4	CSIG1SC	CSIG1SC	—	—	—	URTH1 RTS	ESO0/ INTP6	CSIG0RYO
P4_5	—	—	—	—	—	ADCA0 CNV2	INTP7	CSIG1RYO
P4_6	—	—	—	—	—	ADCA0 CNV1	ESO2/ INTP8	—
P4_7	NMI	—	—	—	—	ADCA0 CNV0	INTP9	—

Note 1. Corresponds to data consistency checking.

2.10.2 List of Control Registers

(1) Port 4 Control Registers

Table 2-43 List of Port 4 Control Registers

Name	Number of Bits			15	14	13	12	11	10	9	8	7	6	5	4	3	2	1	0
	8	16	32																
P4	—	√	—	—	—	—	—	—	—	—	—	√	√	√	√	√	√	√	√
PSR4	—	—	√	—	—	—	—	—	—	—	—	√	√	√	√	√	√	√	√
				—	—	—	—	—	—	—	—	—	—	√	√	√	√	√	√
PPR4	—	√	—	—	—	—	—	—	—	—	—	√	√	√	√	√	√	√	√
PM4	—	√	—	—	—	—	—	—	—	—	—	√	√	√	√	√	√	√	√
PMC4	—	√	—	—	—	—	—	—	—	—	—	√	√	√	√	√	√	√	√
PFC4	—	√	—	—	—	—	—	—	—	—	—	√	√	√	√	√	√	√	√
PFCE4	—	√	—	—	—	—	—	—	—	—	—	√	√	√	√	√	√	√	√
PNOT4	—	√	—	—	—	—	—	—	—	—	—	√	√	√	√	√	√	√	√
PMSR4	—	—	√	—	—	—	—	—	—	—	—	√	√	√	√	√	√	√	√
				—	—	—	—	—	—	—	—	—	—	√	√	√	√	√	√
PMCSR4	—	—	√	—	—	—	—	—	—	—	—	√	√	√	√	√	√	√	√
				—	—	—	—	—	—	—	—	—	—	√	√	√	√	√	√
PIBC4	—	√	—	—	—	—	—	—	—	—	—	√	√	√	√	√	√	√	√
PBDC4	—	√	—	—	—	—	—	—	—	—	—	√	√	√	√	√	√	√	√
PIPC4	—	√	—	—	—	—	—	—	—	—	—	—	—	—	√	—	—	—	—
PU4	—	√	—	—	—	—	—	—	—	—	—	√	√	√	√	√	√	√	√

2.11 Port 5

This section describes alternative functions and control registers of port 5.

2.11.1 Alternative Functions

(1) Alternative Functions of Port 5

Table 2-44 List of Alternative Functions of Port 5

Port Mode (PMC = 0)	Control Mode (PMC = 1)							
	Alternative Mode 1 (PFC = 0, PFCE = 0)		Alternative Mode 2 (PFC = 1, PFCE = 0)		Alternative Mode 3 (PFC = 0, PFCE = 1)		Alternative Mode 4 (PFC = 1, PFCE = 1)	
	Input (PM = 1)	Output (PM = 0)	Input (PM = 1)	Output (PM = 0)	Input (PM = 1)	Output (PM = 0)	Input (PM = 1)	Output (PM = 0)
P5_0	—	—	—	—	URTH0 RXD/ INTP0	—	—	—
P5_1	—	—	—	—	—	URTH0 TXD	ADCA0 TRG0/ INTP3	—
P5_2	—	—	INTP2	—	URTH0SC	URTH0SC	ADCA0 TRG1/ INTP4	—
P5_3	—	—	ADCA0 TRG0/ INTP3	—	URTH0 CTS	—	ADCA0 TRG2/ INTP5	—

2.11.2 List of Control Registers

(1) Port 5 Control Registers

Table 2-45 List of Port 5 Control Registers

Name	Number of Bits			15	14	13	12	11	10	9	8	7	6	5	4	3	2	1	0	
	8	16	32																	
P5	—	√	—	—	—	—	—	—	—	—	—	—	—	—	—	√	√	√	√	
PSR5	—	—	√	—	—	—	—	—	—	—	—	—	—	—	—	—	√	√	√	√
				—	—	—	—	—	—	—	—	—	—	—	—	—	—	—	√	√
PPR5	—	√	—	—	—	—	—	—	—	—	—	—	—	—	—	—	√	√	√	√
PM5	—	√	—	—	—	—	—	—	—	—	—	—	—	—	—	—	√	√	√	√
PMC5	—	√	—	—	—	—	—	—	—	—	—	—	—	—	—	—	√	√	√	√
PFC5	—	√	—	—	—	—	—	—	—	—	—	—	—	—	—	—	√	√	√	√
PFCE5	—	√	—	—	—	—	—	—	—	—	—	—	—	—	—	—	√	√	√	√
PNOT5	—	√	—	—	—	—	—	—	—	—	—	—	—	—	—	—	√	√	√	√
PMSR5	—	—	√	—	—	—	—	—	—	—	—	—	—	—	—	—	√	√	√	√
				—	—	—	—	—	—	—	—	—	—	—	—	—	—	—	√	√
PMCSR5	—	—	√	—	—	—	—	—	—	—	—	—	—	—	—	—	√	√	√	√
				—	—	—	—	—	—	—	—	—	—	—	—	—	—	—	√	√
PIBC5	—	√	—	—	—	—	—	—	—	—	—	—	—	—	—	—	√	√	√	√
PBDC5	—	√	—	—	—	—	—	—	—	—	—	—	—	—	—	—	—	√	√	—
PIPC5	—	√	—	—	—	—	—	—	—	—	—	—	—	—	—	—	—	√	—	—
PU5	—	√	—	—	—	—	—	—	—	—	—	—	—	—	—	—	√	√	√	√

2.12 Port 8

This section describes alternative functions and control registers of port 8.

2.12.1 Alternative Functions

(1) Alternative Functions of Port 8

Table 2-46 List of Alternative Functions of Port 8

Port Mode (PMC = 0)	Control Mode (PMC = 1)							
	Alternative Mode 1 (PFC = 0, PFCE = 0)		Alternative Mode 2 (PFC = 1, PFCE = 0)		Alternative Mode 3 (PFC = 0, PFCE = 1)		Alternative Mode 4 (PFC = 1, PFCE = 1)	
	Input (PM = 1)	Output (PM = 0)	Input (PM = 1)	Output (PM = 0)	Input (PM = 1)	Output (PM = 0)	Input (PM = 1)	Output (PM = 0)
P8_0	—	—	—	TAUB0015	—	OSTM10	—	—

2.12.2 List of Control Registers

(1) Port 8 Control Registers

Table 2-47 List of Port 8 Control Registers

Name	Number of Bits			15	14	13	12	11	10	9	8	7	6	5	4	3	2	1	0
	8	16	32																
P8	—	√	—	—	—	—	—	—	—	—	—	—	—	—	—	—	—	—	√
PSR8	—	—	√	—	—	—	—	—	—	—	—	—	—	—	—	—	—	—	√
				—	—	—	—	—	—	—	—	—	—	—	—	—	—	—	—
PPR8	—	√	—	—	—	—	—	—	—	—	—	—	—	—	—	—	—	—	√
PM8	—	√	—	—	—	—	—	—	—	—	—	—	—	—	—	—	—	—	√
PMC8	—	√	—	—	—	—	—	—	—	—	—	—	—	—	—	—	—	—	√
PFC8	—	√	—	—	—	—	—	—	—	—	—	—	—	—	—	—	—	—	√
PFCE8	—	√	—	—	—	—	—	—	—	—	—	—	—	—	—	—	—	—	√
PNOT8	—	√	—	—	—	—	—	—	—	—	—	—	—	—	—	—	—	—	√
PMSR8	—	—	√	—	—	—	—	—	—	—	—	—	—	—	—	—	—	—	√
				—	—	—	—	—	—	—	—	—	—	—	—	—	—	—	—
PMCSR8	—	—	√	—	—	—	—	—	—	—	—	—	—	—	—	—	—	—	√
				—	—	—	—	—	—	—	—	—	—	—	—	—	—	—	—
PIBC8	—	√	—	—	—	—	—	—	—	—	—	—	—	—	—	—	—	—	√
PBDC8	—	√	—	—	—	—	—	—	—	—	—	—	—	—	—	—	—	—	√
PU8	—	√	—	—	—	—	—	—	—	—	—	—	—	—	—	—	—	—	√

2.13 JTAG Port 0

This section describes alternative functions and control registers of JTAG port 0.

2.13.1 Alternative Functions

(1) Alternative Functions of JTAG Port 0

The JTAG port 0 has no any alternative function pin.

2.13.2 List of Control Registers

(1) JTAG Port 0 Control Registers

Table 2-48 List of JTAG Port 0 Control Registers

Name	Number of Bits			15	14	13	12	11	10	9	8	7	6	5	4	3	2	1	0
	8	16	32																
JPO	√	—	—	—	—	—	—	—	—	—	—	—	—	√	—	√	√	√	—
JPSR0	—	—	√	—	—	—	—	—	—	—	—	—	—	√	—	√	√	√	—
				—	—	—	—	—	—	—	—	—	—	—	—	√	—	√	√
JPPR0	√	—	—	—	—	—	—	—	—	—	—	—	—	√	—	√	√	√	—
JPM0	√	—	—	—	—	—	—	—	—	—	—	—	—	√	—	√	√	√	—
JPNOT0	√	—	—	—	—	—	—	—	—	—	—	—	—	√	—	√	√	√	—
JPMSR0	—	—	√	—	—	—	—	—	—	—	—	—	—	√	—	√	√	√	—
				—	—	—	—	—	—	—	—	—	—	—	—	√	—	√	√
JPIBC0	√	—	—	—	—	—	—	—	—	—	—	—	—	√	—	√	√	√	—
JPU0	√	—	—	—	—	—	—	—	—	—	—	—	—	√	—	√	√	√	—

2.14 Cancelling Noise on Pins

This section describes the noise-filtering insertion pin, filter groups, noise-cancellation sampling clock, and control registers.

2.14.1 Details of Noise Cancellation

(1) Digital Filter Function

The input signal is sampled with the sampling frequency f_s .

If the input is sampled at the same level in a specified number of successive samples, the signal level is judged as valid and the filter output signal is changed accordingly.

If the external signal level changes within the specified number of samples (at the same level), the new signal level is judged to be noise—or a spike—and the level of the output signal from the filter does not change.

The length of an external signal pulse to be judged as noise depends on the sampling frequency and the specified number of same level samples.

Both parameters can be specified.

- DNFACTL.DNFA nPRs[2:0] allows to select the sampling frequency to $f_s = f_{\text{DNFATCKI}} / 2^{\text{DNFA nPRs[2:0]}}$ where f_{DNFATCKI} is the frequency of the DNFATCKI clock.
- DNFACTL.DNFA nFSTs[1:0] specifies the number (2 to 5) of same level samples.

External signal pulses shorter than

$$(\text{DNFA nFSTs[1:0]} - 1) \times 1/f_s$$

Caution If noise is sampled as the same level over the specified number of successive samples, the noise will not be cancelled.

External signal pulses longer than

$$\text{DNFA nFSTs[1:0]} \times 1/f_s$$

are always judged to be valid and passed on to the filter output.

External signal pulses with a width between

$$(\text{DNFA nFSTs[1:0]} - 1) \times 1/f_s \text{ and } \text{DNFA nFSTs[1:0]} \times 1/f_s$$

may be eliminated or judged to be valid.

(2) Noise Filter Insertion Pins and Filter Groups

Table 2-49 List of Noise Filter Insertion Pins and Filter Groups (1/2)

Port Group Name	Port Pin	Filter Insertion Pin	Filter Group
P0	P0_0	INTP0	DNF_INTP-G0
		INTP5	DNF_INTP-G1
		ADCA0TRG2	ADTRG
	P0_1	INTP4	DNF_INTP-G1
		ADCA0TRG1	ADTRG
	P0_2	INTP3	DNF_INTP-G1
ADCA0TRG0		ADTRG	
P1	P1_0	NMI	DNF_NMI-G0
	P1_1	TAUJ0I0	DNF_TAUJ0-G0
	P1_2	TAUJ0I1	DNF_TAUJ0-G0
	P1_3	TAUJ0I2	DNF_TAUJ0-G0
	P1_4	TAUJ0I3	DNF_TAUJ0-G0
	P1_7	INTP0	DNF_INTP-G0
P2	P2_0	TAUB0I0	DNF_TAUB0-G0
		TAUB0I1	DNF_TAUB0-G0
		CSIG0RYI	DNF_CSI-G0
	P2_1	TAUB0I2	DNF_TAUB0-G1
		TAUB0I3	DNF_TAUB0-G1
		CSIG1RYI	DNF_CSI-G0
	P2_2	TAUB0I4	DNF_TAUB0-G2
		TAUB0I5	DNF_TAUB0-G2
	P2_3	TAUB0I6	DNF_TAUB0-G3
		TAUB0I7	DNF_TAUB0-G3
	P2_4	TAUB0I8	DNF_TAUB0-G3
		TAUB0I9	DNF_TAUB0-G3
	P2_5	TAUB0I10	DNF_TAUB0-G5
		TAUB0I11	DNF_TAUB0-G5
	P2_6	TAUB0I12	DNF_TAUB0-G5
		TAUB0I13	DNF_TAUB0-G5
	P2_7	TAUB0I14	DNF_TAUB0-G5
		TAUB0I15	DNF_TAUB0-G5
P3	P3_0	INTP1	DNF_INTP-G0
	P3_5	INTP2	DNF_INTP-G0

Table 2-49 List of Noise Filter Insertion Pins and Filter Groups (2/2)

Port Group Name	Port Pin	Filter Insertion Pin	Filter Group
P4	P4_0	INTP1	DNF_INTP-G0
	P4_1	TSG20PTSI0/ ENCA0E0	DNF_TSG20-G0
	P4_2	TSG20PTSI1/ ENCA0E1	DNF_TSG20-G0
	P4_3	TSG20PTSI2/ ENCA0EC	DNF_TSG20-G1
	P4_4	ESO0	ESO
		INTP6	DNF_INTP-G2
	P4_5	INTP7	DNF_INTP-G2
	P4_6	ESO2	ESO
		INTP8	DNF_INTP-G2
	P4_7	NMI	DNF_NMI-G0
		INTP9	DNF_INTP-G2
	P5	P5_0	INTP0
P5_1		INTP3	DNF_INTP-G1
P5_2		INTP2	DNF_INTP-G0
		INTP4	DNF_INTP-G1
P5_3		INTP3	DNF_INTP-G1
		INTP5	DNF_INTP-G1

(3) Noise Filter Insertion Pins and Filter Groups for**Table 2-50 List of Filter Insertion Pins and Filter Groups for Pins Other than Port**

Pin Name	Filter Insertion Pin	Filter Group
FLMD0	FLMD0	FLMD0
FLMD1	FLMD1	FLMD1
$\overline{\text{RESET}}$	$\overline{\text{RESET}}$	$\overline{\text{RESET}}$
$\overline{\text{DCUTRST}}$	$\overline{\text{DCUTRST}}$	$\overline{\text{DCUTRST}}$

(4) Noise-Cancelling Intervals and Sampling Clock for Noise Cancellation

Table 2-51 List of Noise-Cancelling Intervals and Sampling Clock for Noise Cancellation (1/2)

Filter Group	Function Block	Target Pin	Type (Analog or Digital)	Noise-Cancelling Intervals and Sampling Clock for Noise Cancellation (Clock Selection Group)
RESET	RESET	RESET	Analog filter	Min. 100 ns, Max. 500 ns
DCUTRST	Nexus	DCUTRST		
FLMD0, FLMD1	MODE	FLMD0, FLMD1		Min. 50 ns, Max. 250 ns
ESO	TAPA	ESO0 ESO2		
DNF_NMI-G0	NMI	NMI	Digital filter	<INTP group> 1) PCLK 2) PCLK/2
DNF_INTP-G0	INTC	INTP0		
		INTP1		
		INTP2		
DNF_INTP-G1		INTP3		
		INTP4		
DNF_INTP-G2		INTP5		
		INTP6		
		INTP7		
		INTP8		
		INTP9		
DNF_TAUB0-G0	TAUB0	TAUB010	Digital filter	<TAUB0 group> 1) PCLK 2) PCLK/2 3) TAUB0 ch0 CKEN
DNF_TAUB0-G1		TAUB011		
		TAUB012		
DNF_TAUB0-G2		TAUB013		
		TAUB014		
		TAUB015		
DNF_TAUB0-G3		TAUB016		
		TAUB017		
		TAUB018		
		TAUB019		
DNF_TAUB0-G5		TAUBI10		
		TAUB0111		
		TAUB0112		
		TAUB0113		
		TAUB0114		
		TAUB0115		

Table 2-51 List of Noise-Cancelling Intervals and Sampling Clock for Noise Cancellation (2/2)

Filter Group	Function Block	Target Pin	Type (Analog or Digital)	Noise-Cancelling Intervals and Sampling Clock for Noise Cancellation (Clock Selection Group)
DNF_TAUJ0-G0	TAUJ0	TAUJ0I0	Digital filter	<TAUJ0 group> 1) PCLK 2) PCLK/2 3) TAUJ0 ch0 CKEN
		TAUJ0I1		
		TAUJ0I2		
		TAUJ0I3		
DNF_TSG20-G0	TSG20	TSG20PTSI0/ ENCA0E0 TSG20PTSI1/ ENCA0E1	Digital filter	<TSG2,ENC group> 1) PCLK 2) PCLK/2
DNF_TSG20-G1		TSG20PTSI2/ ENCA0EC		
DNF_CSI-G0	CSIG0	CSIG0RYI		<CSigroup> 1) PCLK 2) PCLK/2
	CSIG1	CSIG1RYI		

Register addresses Addresses of control registers for controlling the digital noise filter are given as the respective offsets from the base address indicated by <DNFn_base>.

The register base address for the various registers, i.e. <DNFn_base>, is given below.

Table 2-52 Base Address <DNFn_base> of Control Registers for Controlling the Digital Noise Filter

<DNFn_base> Address
FF41 0000 _H

2.14.2 Control Registers

The following registers control and run the digital noise filter.

Table 2-53 The List of Registers for the Digital Noise Canceller

Register Function	Name	Address
Digital noise canceller control register	DNFAnCTL	<DNFn_base> + n × 100 _H
Digital noise canceller enable register	DNFAnEN	<DNFn_base> + n × 100 _H + 4
Digital noise canceller enable register L	DNFAnENL	<DNFn_base> + n × 100 _H + C _H
Digital noise filter sampling clock control register	DNFSCTL	FF420034 _H

n = 0 to 36

-
- Caution 1. Do not change the settings of associated control registers (the DNFAnCTL, DNFAnEN, DNFSCTL registers) while DNFAnEN.DNFAnNFENm = 1, which enables the digital filter. Changing the settings can lead to the filter generating unanticipated output.
- Caution 2. Many registers include bits to which no function has been allocated. Unless there is a specific indication to the contrary, do not write values other than the initial values to such bits. Operation is not guaranteed if other values are set in these bits.
-

(1) DNFACTL – Digital Noise Canceller Control Register

This register is used to select the sampling clock for the digital noise canceller.

Access Readable and writable in 8-bit units.

Address Refer to Table 2-53, The List of Registers for the Digital Noise Canceller.

Initial value 00_H

7	6	5	4	3	2	1	0
0	DNFA _n NFSTS[1:0]	0	0	DNFA _n PRS[2:0]			
R/W	R/W	R/W	R/W	R/W	R/W	R/W	R/W

Table 2-54 Contents of Register DNFACTL

Bit Position	Bit Name	Function
6, 5	DNFA _n NFSTS[1:0]	Number of samples at the same level for judgment to validate or invalidate an external pulse 00: Two 01: Three 10: Four 11: Five
2 to 0	DNFA _n PRS[2:0]	Digital filter sampling clock selection 000: DNFATCKI / 1 001: DNFATCKI / 2 010: DNFATCKI / 4 011: DNFATCKI / 8 100: DNFATCKI / 16 101: DNFATCKI / 32 110: DNFATCKI / 64 111: DNFATCKI / 128 DNFATCKI is the clock signal selected in the DNFSCTL register.

Table 2-55 List of DNFA_nCTL registers

Register Name/ Address	Filter Group	Target Pin
DNFA0CTL FF410000	DNF_NMI-G0	NMI
DNFA1CTL FF410100	DNF_INTP-G0	INTP0, INTP1, INTP2
DNFA2CTL FF410200	DNF_INTP-G1	INTP3, INTP4, INTP5
DNFA3CTL FF410300	DNF_INTP-G2	INTP6, INTP7, INTP8, INTP9
DNFA4CTL FF410400	DNF_TAUB0-G0	TAUB0I0, TAUB0I1
DNFA5CTL FF410500	DNF_TAUB0-G1	TAUB0I2, TAUB0I3
DNFA6CTL FF410600	DNF_TAUB0-G2	TAUB0I4, TAUB0I5
DNFA7CTL FF410700	DNF_TAUB0-G3	TAUB0I6, TAUB0I7 TAUB0I8, TAUB0I9
DNFA9CTL FF410900	DNF_TAUB0-G5	TAUB0I10, TAUB0I11 TAUB0I12, TAUB0I13 TAUB0I14, TAUB0I15
DNFA20CTL FF411400	DNF_TAUJ0-G0	TAUJ0I0, TAUJ0I1 TAUJ0I2, TAUJ0I3
DNFA28CTL FF411C00	DNF_TSG20-G0	TSG20PTSI0/ENCA0E0 TSG20PTSI1/ENCA0E1
DNFA29CTL FF411D00	DNF_TSG20-G1	TSG20PTSI2/ENCA0EC
DNFA36CTL FF412400	DNF_CSI-G0	CSIG0RYI, CSIG1RYI

(2) DNFA_nEN – Digital Noise Canceller Enable Register

This register specifies enabling and disabling of the digital noise cancellers.

Access Readable and writable in 16-bit units.

Address Refer to Table 2-53, The List of Registers for the Digital Noise Canceller.

Initial value 0000_H

15	14	13	12	11	10	9	8
DNFA _n NFEN[15:8]							
R/W	R/W	R/W	R/W	R/W	R/W	R/W	R/W
7	6	5	4	3	2	1	0
DNFA _n NFEN[7:0]							
R/W	R/W	R/W	R/W	R/W	R/W	R/W	R/W

Table 2-56 DNFA_nEN Register Contents

Bit Position	Bit Name	Function
15 to 0	DNFA _n NFEN [15:0]	<p>Each bit enables or disables digital noise cancellation for the signal on the corresponding pin.</p> <ul style="list-style-type: none"> • DNFA0EN to DNFA3EN registers If the NMI or INTPO to INTP9 is in use, set the corresponding bit to 1. <ul style="list-style-type: none"> - DNFA0EN.DNFA0NFEN[0] bit - DNFA1EN.DNFA1NFEN[2-0] bits - DNFA2EN.DNFA2NFEN[2-0] bits - DNFA3EN.DNFA3NFEN[3-0] bits • DNFA2EN register If the ADCA0TRG0, ADCA0TRG1, or ADCA0TRG2 multiplexed function is in use, set the corresponding bit to 0. <ul style="list-style-type: none"> - DNFA2EN.DNFA2NFEN[2-0] bits • DNFA3EN register If any of the ESO0, ESO2 multiplexed functions is in use, set the corresponding bit to 0. <ul style="list-style-type: none"> - DNFA3EN.DNFA3NFEN[2, 0] bits • DNFA4EN to DNFA36EN registers 0:Digital noise cancellation is disabled. 1:Digital noise cancellation is enabled.

- Caution 1. When writing to DNFA_nEN registers, be sure to write 0 to DNFA_nEN.DNFA_nENm bits for which “0” is the entry as shown in Table 2-57, List of DNFA_nEN Registers. Operation is not guaranteed if any such bit is set to 1.
- Caution 2. When the output signal from the digital filter is set to an input for an alternative function, allow at least the following interval to elapse after the digital filter is enabled (DNFA_nEN.DNFA_nNFENm = 1) for the port pin to switch to the alternative function.
- $$\text{DNFA}_n\text{NFSTS}[1:0] \times 1/f_s + 4 \times 1/f_{\text{DNFATCKI}}$$
- Caution 3. When a digital filter is used with an interrupt acting as an event output signal, only enable the digital filter (by setting DNFA_nEN.DNFA_nNFENm = 1) while interrupts are disabled. Furthermore, only enable interrupts after enabling the digital filter, waiting for the time below to elapse, and then clearing the interrupt request flag.
- $$\text{DNFA}_n\text{NFSTS}[1:0] \times 1/f_s + 5 \times 1/f_{\text{DNFATCKI}}$$

Table 2-57 List of DNFA_nEN Registers

Register Name, Address	15	14	13	12	11	10	9	8	7	6	5	4	3	2	1	0			
DNFA0EN FF410004	0	0	0	0	0	0	0	0	0	0	0	0	0	0	0	DNFA0NFEN 0(NMI)			
DNFA1EN FF410104	0	0	0	0	0	0	0	0	0	0	0	0	0	DNFA1NFEN 2(INTP2)	DNFA1NFEN 1(INTP1)	DNFA1NFEN 0(INTP0)			
DNFA2EN FF410204	0	0	0	0	0	0	0	0	0	0	0	0	0	DNFA2NFEN 2 (INTP5/ ADCA0TRG2)	DNFA2NFEN 1 (INTP4/ ADCA0TRG1)	DNFA2NFEN 0 (INTP3/ ADCA0TRG0)			
DNFA3EN FF410304	0	0	0	0	0	0	0	0	0	0	0	0	0	DNFA3NFEN 3 (INTP9)	DNFA3NFEN 2 (ESO2, INTP8)	DNFA3NFEN 1 (INTP7)	DNFA3NFEN 0 (ESO0, INTP6)		
DNFA4EN FF410404	0	0	0	0	0	0	0	0	0	0	0	0	0	0	DNFA4NFEN 1 (TAUB01)	DNFA4NFEN 0 (TAUB00)			
DNFA5EN FF410504	0	0	0	0	0	0	0	0	0	0	0	0	0	0	DNFA5NFEN 1 (TAUB03)	DNFA5NFEN 0 (TAUB02)			
DNFA6EN FF410604	0	0	0	0	0	0	0	0	0	0	0	0	0	0	DNFA6NFEN 1 (TAUB05)	DNFA6NFEN 0 (TAUB04)			
DNFA7EN FF410704	0	0	0	0	0	0	0	0	0	0	0	0	0	0	DNFA7NFEN 2 (TAUB08)	DNFA7NFEN 1 (TAUB07)	DNFA7NFEN 0 (TAUB06)		
DNFA9EN FF410904	0	0	0	0	0	0	0	0	0	0	0	DNFA9NFEN 5 (TAUB015)	DNFA9NFEN 4 (TAUB014)	DNFA9NFEN 3 (TAUB013)	DNFA9NFEN 2 (TAUB012)	DNFA9NFEN 1 (TAUB011)	DNFA9NFEN 0 (TAUB010)		
DNFA20EN FF411404	0	0	0	0	0	0	0	0	0	0	0	0	0	DNFA20NFE N3 (TAUJ013)	DNFA20NFE N2 (TAUJ012)	DNFA20NFE N1 (TAUJ011)	DNFA20NFE N0 (TAUJ010)		
DNFA28EN FF411C04	0	0	0	0	0	0	0	0	0	0	0	0	0	0	DNFA28NFE N1 (TSG20PTS1 /ENCA0E1)	DNFA28NFE N0 (TSG20PTS10 /ENCA0E0)			
DNFA29EN FF411D04	0	0	0	0	0	0	0	0	0	0	0	0	0	0	0	DNFA29NFE N0 (TSG20PTS12 /ENCA0EC)			
DNFA36EN FF412404	0	0	0	0	0	0	0	0	0	0	0	0	0	0	0	DNFA36NFE N3 (CSIG1RYI)	DNFA36NFE N2 (CSIG0RYI)	0	0

(3) Digital Noise Canceller Enable Register L

This register is the 8 lower-order bits of DNFA_nEN register.

Access This register is readable/writable in 8 or 1-bit units.

Address Refer to Table 2-53, The List of Registers for the Digital Noise Canceller.

Initial value 00_H

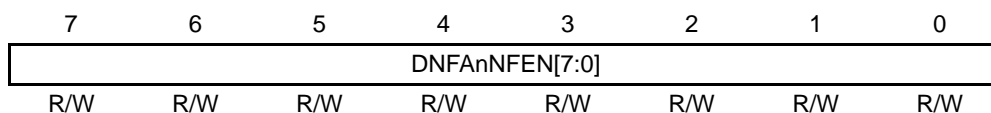

For details of each bit operation, see DNFA_nEN register.

(4) Digital Noise Filter Sampling Clock Control Register

This register selects the digital noise filter sampling clock.

Access Readable and writable in 16-bit units.

Address Refer to Table 2-53, The List of Registers for the Digital Noise Canceller.

Initial value 0000_H

15	14	13	12	11	10	9	8
0	0	DNFCKSL6[1:0]	0	0	0	DNFCKSL4[1:0]	
R	R	R/W	R/W	R	R	R/W	R/W
7	6	5	4	3	2	1	0
0	0	0	DNFCKSL20	0	DNFCKSL10	0	DNFCKSL00
R	R	R	R/W	R	R/W	R	R/W

Table 2-58 DNFCKCTL Register Contents

Bit Position	Bit Name	Function
13, 12	DNFCKSL61, 60	Selects the sampling clock of the TAUJ0 group. 00: PCLK 01: PCLK/2 10: TAUJ0 ch0 CKEN signal 11: Setting prohibited
9, 8	DNFCKSL41, 40	Selects the sampling clock of the TAUB0 group. 00: PCLK 01: PCLK/2 10: TAUB0 ch0 CKEN signal 11: Setting prohibited
4	DNFCKSL20	Selects the sampling clock of the CSI group. 0: PCLK 1: PCLK/2
2	DNFCKSL10	Selects the sampling clock of the TSG2 group. 0: PCLK 1: PCLK/2
0	DNFCKSL00	Selects the sampling clock of the INTP group. 0: PCLK 1: PCLK/2

Caution Only set this register while the operation of the corresponding DNF is not enabled. Operation cannot be guaranteed if these settings are made while the operation of a corresponding DNF is enabled.

2.15 Edge Detection

This section the pins and control registers used with edge detection.

2.15.1 Details of Edge Detection

(1) Pins for Use in Edge Detection

Table 2-59 List of Pins for Use in Edge Detection

Target Pin	Control Register Name
NMI	FCLA0CTL0
INTP0	FCLA1CTL0
INTP1	FCLA1CTL1
INTP2	FCLA1CTL2
INTP3	FCLA1CTL3
INTP4	FCLA1CTL4
INTP5	FCLA1CTL5
INTP6	FCLA1CTL6
INTP7	FCLA1CTL7
INTP8	FCLA2CTL0
INTP9	FCLA2CTL1

2.15.2 Control Register

(1) FCLAnCTLM-Filter Control Register

This register specifies operation of the edge detection function.

Access Readable and writable in 8-bit units.

Address Refer to Table 2-61, List of FCLAnCTLM Registers.

Initial value 00_H

7	6	5	4	3	2	1	0
0	0	0	0	0	0	FCLAn INTFm	FCLAn INTRm
R	R	R	R	R	R	R/W	R/W

Table 2-60 FCLAnCTLM Register Contents

Bit Position	Bit Name	Function
1	FCLAnINTFm	Controls falling edge detection of the input signal 0: Falling edge detection disabled 1: Falling edge detection enabled
0	FCLAnINTRm	Controls rising edge detection of the input signal 0: Rising edge detection disabled 1: Rising edge detection enabled

Note If FCLAnINTFm = 0 and FCLAnINTRm = 0, no edge detection is done.
If FCLAnINTFm = 1 and FCLAnINTRm = 1, both edges are recognized as valid.

Table 2-61 List of FCLAnCTLM Registers

FCLAn	Register Name	Register Address	Generated Interrupt
FCLA0	FCLA0CTL0	FF414000	NMI
FCLA1	FCLA1CTL0	FF414100	INTP0
	FCLA1CTL1	FF414104	INTP1
	FCLA1CTL2	FF414108	INTP2
	FCLA1CTL3	FF41410C	INTP3
	FCLA1CTL4	FF414110	INTP4
	FCLA1CTL5	FF414114	INTP5
	FCLA1CTL6	FF414118	INTP6
FCLA2	FCLA1CTL7	FF41411C	INTP7
	FCLA2CTL0	FF414200	INTP8
	FCLA2CTL1	FF414204	INTP9

Caution Many registers include bits to which no function has been allocated. Unless there is a specific indication to the contrary, do not write values other than the initial values to such bits. Operation is not guaranteed if other values are set in these bits.

Section 3 CPU System Function

This section describes the registers of the CPU, the operation modes, the address space and the memory areas.

For details on the functions of the CPU, refer to manuals as indicated below.

Table 3-1 Descriptions of CPU Functions

Function	V850E2M Architecture (R01US0001E)	This Manual
V850E2 CPU (including instruction set)	√	–
Processor protection functions (MPU, SRP, PPU, TSU)	√	–
DMA controller (DMAC)	–	√
Interrupt controller (INTC)	–	√
Code flash/data flash memory	–	√
On-chip RAM	–	√

3.1 Overview

- CPU**
- Core architecture: V850E2M architecture class
 - Instruction execution times:

Device	Minimum Instruction Execution Time	Maximum CPU Clock
μPD70F4154	12.5 ns	80 MHz
μPD70F4155	12.5 ns	80 MHz

- Internal 32-bit architecture
- 7-stage pipeline
- 32 × 32-bit general purpose registers
- 2-way superscalar
- Memory space:
 - 512-Mbyte linear program space
 - 4-Gbyte linear data space

- Flash and cache:
 - 8 Kbytes, 2-way associative (4 Kbytes per way)
- Interrupt controller (INTC)
- DMA controller (DMAC)
- Processor protection functions
 - Memory protection unit (MPU)
Protection against illegal execution from or data manipulation of CPU memory areas (up to 5 areas in instruction space, up to 6 areas in data space)
 - System register protection (SRP)
Protection against damage to the system registers by a non-trusted programs
 - Peripheral protection unit (PPU)
Protection against illegal access to peripheral modules
 - Timing supervision unit (TSU)
Protection against inappropriate CPU time possession by a non-trusted program, and resources and time of disabling interrupts can be managed
- Instruction set**
 - V850E2 instruction set compatible to former V850 instruction sets plus additional powerful instructions for reduced code size and increasing execution speed
 - Signed multiplication operations in 1 clock
 - 16 bits × 16 bits → 32 bits
 - 32 bits × 32 bits → 32 bits or 64 bits
 - 32 bits × 32 bits → 64 bits
 - Saturated operation instructions with overflow/underflow detection
 - 32-bit shift instructions in 1 clock
 - Bit manipulation instructions (SET1, CLR1, NOT1, TST1)
 - Load/store instructions with long/short format
 - Signed load instructions
 - MAC operation
32 bits × 32 bits + 64 bits → 64 bits

3.1.1 Peripheral Protection Unit

PPU base address The addresses of the peripheral protection unit registers described in the “V850E2M Architecture Manual (R01US0001E)” are given as offset addresses. The base address is as follows:

$$\langle \text{PPU_base} \rangle = \text{FFFF } 5100_{\text{H}}$$

PPU areas and registers The control registers for each protected area comprise 4 registers.

- PPVn – Validating general peripheral device protection
- PPTn – Specification protection type of general peripheral device
- PPPn – Specification of OS peripheral device
- PPSn – Specification of special peripheral device

These registers are numbered with n = 0 to 8.

The bits in these 32-bit wide registers are named with m = 0 to 31.

- PPVn.PPVnm
- PPTn.PPTnm
- PPPn.PPPnm
- PPSn.PPSnm

The protected address ranges, their control registers and bits and the modules in the respective address are listed in Table 3-2, PPU Protected Areas and Modules.

Table 3-2 PPU Protected Areas and Modules (1/4)

Protection Range Size	Protection Control		Module Name	Address Range
	Registers PPVn, PPTn, PPPn, PPSn n =	Bits PPVnm, PPTnm, PPPnm, PPSnm m =		
1120 B	0	0	INTC	FFFF 6000 _H - FFFF 645F _H
4 B		3	System error	FFFF 64B0 _H - FFFF 64B3 _H
1024B		16	TSU/PPU	FFFF 5000 _H - FFFF 53FF _H
256 B		23	DMAC	FFFF 7300 _H - FFFF 73FF _H
256 B		24		FFFF 7400 _H - FFFF 74FF _H
512 B		28		FFFF 7B00 _H - FFFF 7CFF _H
512 B		29		FFFF 7D00 _H - FFFF 7EFF _H
64 KB	1	0	Port Pnm control	FF40 0000 _H - FF40 FFFF _H
		1	Port filters control	FF41 0000 _H - FF41 FFFF _H
		2	Clock generator Reset controller	FF42 0000 _H - FF42 FFFF _H
		3	Code flash ECC Data flash access wait FLMD control	FF43 0000 _H - FF43 FFFF _H
		4	Port JPmn control	FF44 0000 _H - FF44 FFFF _H

Table 3-2 PPU Protected Areas and Modules (2/4)

Protection Range Size	Protection Control		Module Name	Address Range
	Registers PPVn, PPTn, PPPn, PPSn n =	Bits PPVnm, PPTnm, PPPnm, PPSnm m =		
64 KB	1	5	POF/LVI control PBUS error/access control	FF45 0000 _H - FF45 FFFF _H
		6	FCN, on-chip RAM ECC	FF46 0000 _H - FF46 FFFF _H
		7	Optional byte Product information	FF47 0000 _H - FF47 FFFF _H
		8	FCN0	FF48 0000 _H - FF48 FFFF _H
		9		FF49 0000 _H - FF49 FFFF _H
		10	FCN1	FF4A 0000 _H - FF4A FFFF _H
		11		FF4B 0000 _H - FF4B FFFF _H
		28	UARTH0	FF5C 0000 _H - FF5C FFFF _H
		29	UARTH1	FF5D 0000 _H - FF5D FFFF _H
64 KB	2	16	CSIG0	FF70 0000 _H - FF70 FFFF _H
		17	CSIG1	FF71 0000 _H - FF71 FFFF _H
4 KB	3	0	OSTM0	FF80 0000 _H - FF80 0FFF _H
		1	OSTM1	FF80 1000 _H - FF80 1FFF _H
		2	CLMA0	FF80 2000 _H - FF80 2FFF _H
		3	CLMA1	FF80 3000 _H - FF80 3FFF _H
		4	CLMA2	FF80 4000 _H - FF80 4FFF _H
		6	WDTA0	FF80 6000 _H - FF80 6FFF _H
		8	TAUB0	FF80 8000 _H - FF80 8FFF _H
		17	TAUJ0	FF81 1000 _H - FF81 1FFF _H
		21	TAPA0	FF81 5000 _H - FF81 5FFF _H
		23	TAPA2	FF81 7000 _H - FF81 7FFF _H
		25	ENCA0	FF81 9000 _H - FF81 9FFF _H
		28	PIC function	FF81 C000 _H - FF81 CFFF _H
		29	ADCA0	FF81 D000 _H - FF81 DFFF _H

Table 3-2 PPU Protected Areas and Modules (3/4)

Protection Range Size	Protection Control		Module Name	Address Range
	Registers PPVn, PPTn, PPPn, PPSn n =	Bits PPVnm, PPTnm, PPPnm, PPSnm m =		
4 KB	4	14	TSG20	FF82 E000 _H - FF82 EFFF _H
		18	TPBA0	FF83 2000 _H - FF83 2FFF _H
		22	DCRA0	FF83 6000 _H - FF83 6FFF _H
		23	DCRA1	FF83 7000 _H - FF83 7FFF _H
		25	BRGA0	FF83 9000 _H - FF83 9FFF _H
		26	INTC	FF83 A000 _H - FF83 AFFF _H
		27	Self-diagnosis BIST	FF83 B000 _H - FF83 BFFF _H
		28	SGA	FF83 C000 _H - FF83 CFFF _H
		29		FF83 D000 _H - FF83 DFFF _H
		30		FF83 E000 _H - FF83 EFFF _H
			31	OSTM input clock select SGA error pulse output control Backup RAM registers On-chip RAM resumption- standby control register
256 B	5	0	Port	FFFF 8000 _H - FFFF 80FF _H
		1		FFFF 8100 _H - FFFF 81FF _H
		2		FFFF 8200 _H - FFFF 82FF _H
		3		FFFF 8300 _H - FFFF 83FF _H
		4		FFFF 8400 _H - FFFF 84FF _H
		5		FFFF 8500 _H - FFFF 85FF _H
		6		FFFF 8600 _H - FFFF 86FF _H
		7		FFFF 8700 _H - FFFF 87FF _H
		8		FFFF 8800 _H - FFFF 88FF _H
		9		FFFF 8900 _H - FFFF 89FF _H
256 B	7	0	OSTM0	FFFF C000 _H - FFFF C0FF _H
		1	OSTM1	FFFF C100 _H - FFFF C1FF _H
		2	TAUJ0	FFFF C200 _H - FFFF C2FF _H
		4	TAUB0	FFFF C400 _H - FFFF C4FF _H
		5		FFFF C500 _H - FFFF C5FF _H
		6		FFFF C600 _H - FFFF C6FF _H
		7		FFFF C700 _H - FFFF C7FF _H
		12	TSG20	FFFF CC00 _H - FFFF CCFF _H
		20	TAPA0	FFFF D400 _H - FFFF D4FF _H
		22	TAPA2	FFFF D600 _H - FFFF D6FF _H
		24	ENCA0	FFFF D800 _H - FFFF D8FF _H
		27	PIC function	FFFF DB00 _H - FFFF DBFF _H
		28	ADCA0	FFFF DC00 _H - FFFF DCFF _H

Table 3-2 PPU Protected Areas and Modules (4/4)

Protection Range Size	Protection Control		Module Name	Address Range
	Registers PPVn, PPTn, PPPn, PPSn n =	Bits PPVnm, PPTnm, PPPnm, PPSnm m =		
256 B	8	4	CSIG0	FFFF E400 _H - FFFF E4FF _H
		5	CSIG1	FFFF E500 _H - FFFF E5FF _H
		10	UART0	FFFF EA00 _H - FFFF EAFF _H
		11	UART1	FFFF EB00 _H - FFFF EBFF _H
		16	TPBA0	FFFF F000 _H - FFFF F0FF _H
		17		FFFF F100 _H - FFFF F1FF _H
		26	DCRA0	FFFF FA00 _H - FFFF FAFF _H
		:	:	:
		30	Baud-rate detection in operation as a slave device for LIN communications	FFFF FE00 _H - FFFF FEFF _H

3.1.2 Important Reminders

Please be aware of the following points regarding functions as described in the V850E2M Architecture Manual (R01US0001E).

(1) Branching Instructions and Loading Instructions

When a branching instruction and a loading instruction are consecutive in memory, parallel execution of the pipelines means that the loading instruction which immediately follows the branching instruction is executed (but discarded by the CPU) even if the preceding instruction leads to a branch.

An ECC error occurs if the loading instruction that immediately follows the branching instruction is in an area of on-chip RAM that is not initialized (this does not apply when the loading instruction is in the flash area).

Applicable branching instructions are Bcond, JARL, JMP, and JR

Applicable loading instructions are LD and SLD

Use any one of the following methods to avoid the above phenomenon.

- Initialize the on-chip RAM area before using it.
- Insert an NOP instruction between each branching instruction and the loading instruction following it (write this in assembler because it may be eliminated by optimization if the C language is used).

3.1.3 Timing Supervision Unit

TSU base address The addresses of the timing supervision unit registers described in the “V850E2M Architecture Manual (R01US0001E)” are given as offset addresses. The base address is as follows:

<TSU_base> = FFFF 5000_H

3.2 Operation Modes

This section describes the operation modes of this product and how the modes are selected.

The following operation modes are available:

- Normal operation mode
- Flash programming mode

After reset release by $\overline{\text{RESET}}$ pin, the microcontroller starts to fetch instructions from an internal boot ROM which contains the internal firmware. The firmware checks the FLMD0 and FLMD1 pins, to set the operation mode after reset release according to the table below.

Note When the FLMD0 pin is in use, connect a resistor with a value of at least 270 k Ω to pull it down to the EVSS level.

Table 3-3 Selecting an Operation Mode

Pin		Operation Mode
FLMD0	FLMD1	
0	0	Operation mode (single-chip mode)
1	0	Flash programming mode
Other than the above		Setting prohibited

3.2.1 Normal Operation Mode

This mode enables to access the on-chip ROM.

In single-chip mode, instruction processing starts with a branch to the reset entry address in the on-chip ROM after release from the system-reset state.

3.2.2 Flash Programming Mode

This mode allows the programming of on-chip flash memory by the flash writer. Flash memory is programmable through Nexus communications.

For details, see Section 6, Memory Modules.

3.2.3 HALT Mode

(1) Setting and Operation of HALT Mode

In normal operation mode, HALT mode is selected by executing a dedicated instruction (the HALT instruction). In HALT mode, pipeline operation of the CPU is stopped but clock signals continue to be supplied to the clock oscillation circuit and other on-chip peripheral modules.

This allows the stopping of program execution while retaining the on-chip RAM in the same condition as before the HALT mode setting. Furthermore, on-chip peripheral modules that are independent of instruction processing by the CPU continue to operate. The average current drawn by the overall system can be reduced by alternation between the HALT and normal operating modes.

Table 3-4 State of Operations in HALT Mode

Function	State of Operations
Clock generator	Operating
CPU system clock	Operating
Peripheral clock (PCLK)	Operating
CPU	Stopped
Peripheral I/O	Operating
Internal data	The states of internal data for which reprogramming is not possible while the CPU is stopped, such as the values of registers, status bits, and other data in the CPU and on-chip RAM, are retained from before the setting of HALT mode.

(2) Cancelling HALT Mode

The transition from HALT mode to normal operating mode is in response to the input of a reset, or to the generation of an interrupt or other exception. Following the acceptance of any interrupt or exception, program counting by the program counter resumes from the address of the instruction after the HALT instruction.

Input of any of the following resets or the generation of any of the following interrupts or exceptions constitutes a request for release from HALT mode.

- Reset input ($\overline{\text{RESET}}$, $\overline{\text{WDTA0RES}}$, $\overline{\text{CLMA0RES}}$ to $\overline{\text{CLMA2RES}}$, $\overline{\text{LVIRES}}$, $\overline{\text{SGARES}}$, $\overline{\text{DBRES}}$)
- EI level maskable interrupt (EIINT)
- FE level maskable interrupt (FEINT)
- FE level non-maskable interrupt (FENMI)
- Peripheral device protection exception (PPI)
- Timing supervision exception (TSI)
- System error exception (SYSERR)

3.3 Address Space

This section describes the address space of the CPU (sizes and addresses of the CPU address space and physical address space).

The address range of data space and program space together with their wraparound properties are presented.

3.3.1 CPU Data Address and Physical Program Address Space

The CPU supports the following address spaces.

- 4-GB CPU data address space
With the 32-bit general purpose registers, addresses for a 4-Gbyte memory can be generated. This is the maximum address space supported by the CPU.
- 512-Mbyte physical program address space
The CPU provides 512-Mbyte physical address space to access instruction codes in program memory. That means that a maximum of 512-Mbyte internal or external program memory can be accessed.

3.3.2 Program and Data Space

The figure below shows the assignment of the CPU address space to data and program space.

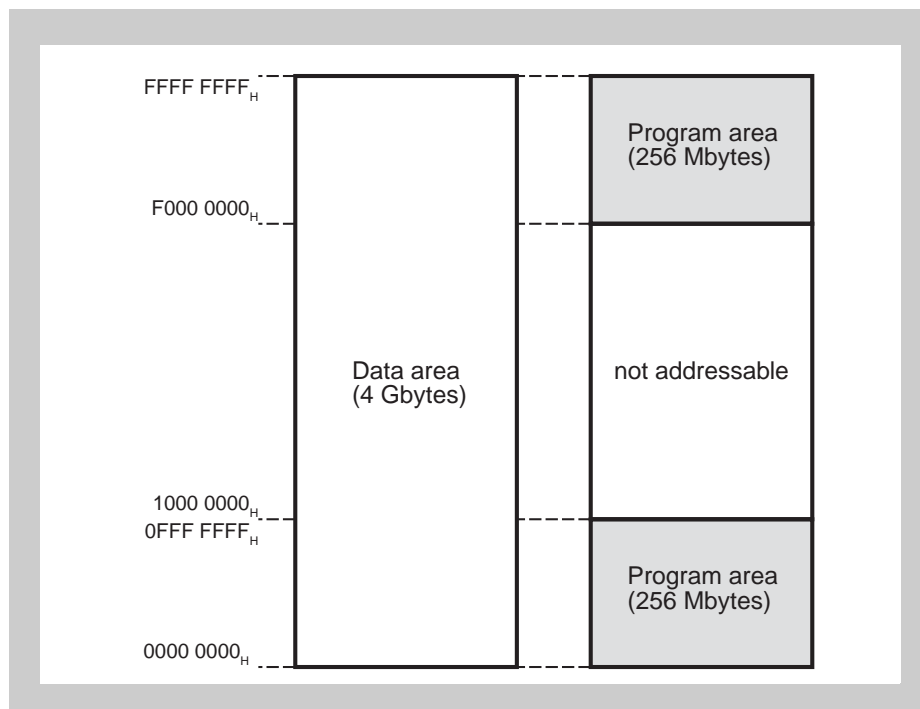

Figure 3-1 CPU Address Space

(1) Wrap-Around of Data Space

If an operand address calculation exceeds 32 bits, only the lower 32 bits of the result are considered. Therefore, the addresses $FFFF\ FFFF_H$ and $0000\ 0000_H$ are contiguous addresses. This results in a wrap-around of the data space:

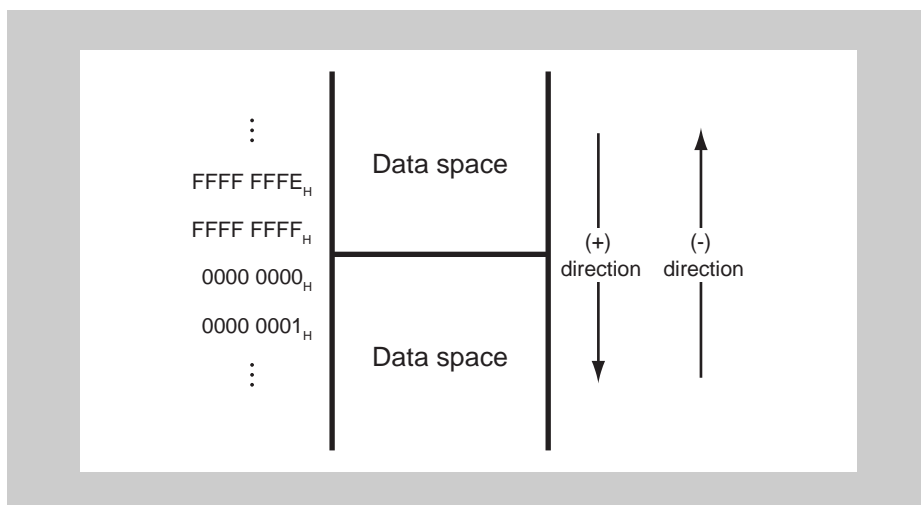

Figure 3-2 Wrap-Around of Data Space

(2) Wrap-Around of Program Space

If an instruction address calculation exceeds 28 bits, only the lower 28 bits of the result are considered. Therefore, the addresses $0000\ 0000_H$ and $0FFF\ FFFF_H$ are contiguous addresses. This results in a wrap-around of the program space:

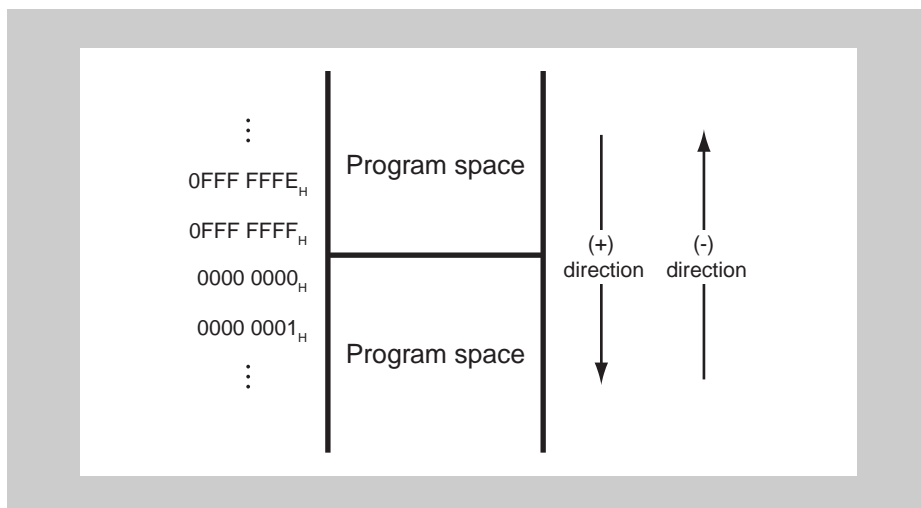

Figure 3-3 Wrap-Around of Program Space

3.4 Conditions for Boundary Operations

3.4.1 Program Space

Branching to the peripheral I/O area or consecutive fetching from the RAM area to peripheral I/O area should not proceed. Such branching or consecutive fetching can lead to the fetching of undefined data.

Caution Executing an executable instruction allocated to a location within 48 bytes of the last address of a memory area (code flash or on-chip RAM) may lead to an ECC error (undefined instructions are not executed).

3.4.2 Data Space

This product is capable of handling misaligned data.

This allows the allocation of data to any address regardless of the unit of data (word or half-word). However, for a word or half-word of data, at least 2 bus cycles are generated unless the data are aligned with the corresponding boundary, and this decreases bus efficiency.

(1) Access to Data with Half-Word Length

If the lowest-order address bit is 1, 2 cycles of byte-length bus access are generated.

(2) Access to Data with Word Length

- If the lowest-order address bit is 1, 3 bus cycles are generated in the following order: byte length, half-word length, and byte length.
- If the 2 lower-order address bits are 10, 2 bus cycles of half-word access are generated.

3.5 Memory Mapping

This section describes memory maps for the CPU and the address map for DMA.

3.5.1 Memory Map for DMA Access

For details, refer to Section 5.3.3, Memory Map for DMA Access.

3.5.2 Memory Map

(1) Memory Map

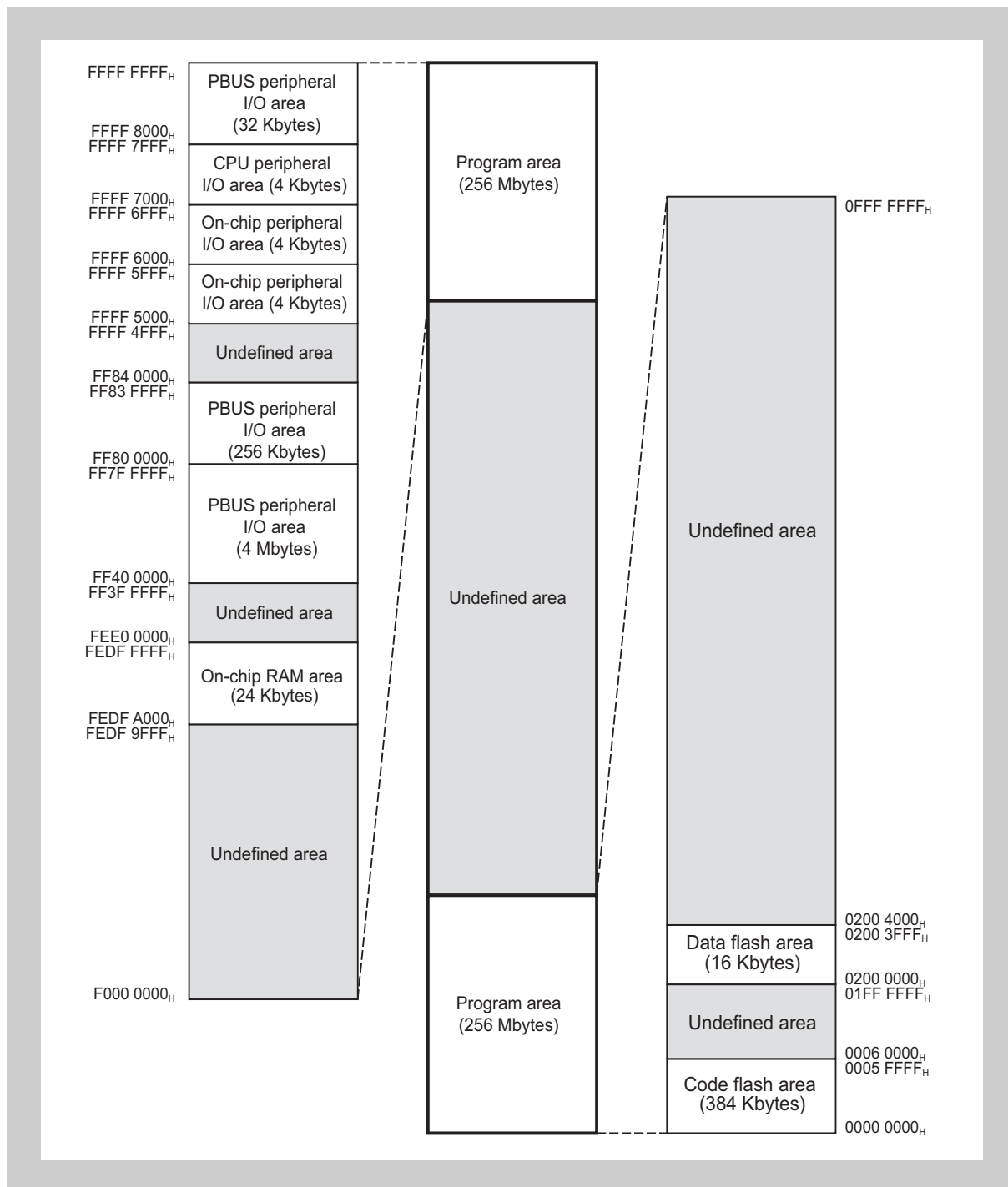

Figure 3-4 Memory Map

3.6 CPU-Related Registers

This section describes CPU related registers.

3.6.1 Overview of CPU-Related Registers

Table 3-5 List of CPU-Related Registers

Register Name	Symbol	Address
Processor element identifier register	PEID	FFFF 6490 _H
Data flash access wait setting register	DCLKWAIT	FF43 6000 _H

3.6.2 CPU-Related Registers in Detail

(1) PEID - Processor Element Identifier Register

The PEID register returns the processor-element identifier of the last accessing CPU.

Access Readable in 16 bit-units

Address FFFF 6490_H

Initial value 0001_H

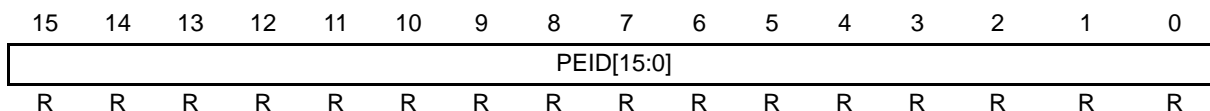

Table 3-6 PEID Register

Bit Position	Bit Name	Function
15 to 0	PEID[15:0]	These bits indicate a processor element ID and are always read as 0001 _H .

(2) DCLKWAIT - Data Flash Access Wait Setting Register

This register is used to set a waiting time for access to data-flash memory.

Access Readable/writable in 8-bit units.

Address FF43 6000_H

Initial value Initialized to the value 1F_H by a reset from any source.

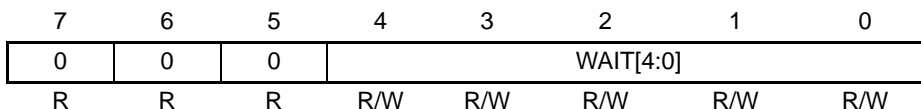

Table 3-7 DCLKWAIT Register

Bit Position	Bit Name	Function								
4 to 0	WAIT[4:0]	<p>These bits are used to set a waiting time for access to data-flash memory. Specify the setting that corresponds to the operating frequency of the CPU.</p> <table border="1" style="width: 100%; border-collapse: collapse;"> <thead> <tr> <th style="width: 30%;">Setting Value</th> <th style="width: 70%;">Description</th> </tr> </thead> <tbody> <tr> <td>11_H</td> <td>Setting when the CPU is operating at 48 MHz to 80 MHz</td> </tr> <tr> <td>1F_H</td> <td>(Initial value)</td> </tr> <tr> <td>Other than the above</td> <td>Settings are prohibited.</td> </tr> </tbody> </table>	Setting Value	Description	11 _H	Setting when the CPU is operating at 48 MHz to 80 MHz	1F _H	(Initial value)	Other than the above	Settings are prohibited.
Setting Value	Description									
11 _H	Setting when the CPU is operating at 48 MHz to 80 MHz									
1F _H	(Initial value)									
Other than the above	Settings are prohibited.									

Caution After release from the reset state, set the waiting time for access by the time of the first access to data-flash memory.

3.7 System Error Notification Function

This section describes the registers involved in system error notification.

3.7.1 Overview of System Error Notification Registers

Table 3-8 List of System Error Notification Function Registers

Register Name	Symbol	Address
System error control register	SEG_CONT	FFFF 64B0 _H
	SEG_CONTL	
System error flag register	SEG_FLAG	FFFF 64B2 _H
	SEG_FLAGL	

3.7.2 System Error Notification Function Registers in Detail

(1) SEG_CONT – System Error Control Register (SEG_CONT, SEG_CONTL)

This register is used to set up the generation of SYSERR exceptions due to system error sources.

Access SEG_CONT is readable/writable in 16-bit units.

SEG_CONTL consists of the 8 lower-order bits of SEG_CONT and is readable/writable in 8- and 1-bit units.

Address FFFF 64B0_H

Initial value 0000_H

	15	14	13	12	11	10	9	8
SEG_CONT	0	0	0	0	0	0	0	0
	R	R	R	R	R	R	R	R
	7	6	5	4	3	2	1	0
(SEG_CONTL)	SEG_ CONT DMAE	0	SEG_ CONT SEGE	SEG_ CONT RAME	0	SEG_ CONT EXTE	SEG_ CONT FCHE	0
	R/W	R	R/W	R/W	R	R/W	R/W	R

Table 3-9 SEG_CONT Register

Bit Position	Bit Name	Function
7	SEG_ CONT DMAE	<p>DMA error notification enable</p> <p>This bit is used to set the behavior when DMA access leads to the following errors.</p> <ul style="list-style-type: none"> • Uncorrectable ECC error in access to data in the code-flash area • Uncorrectable ECC error in access to data in the on-chip RAM area • Access to the reserved area (undefined area) <p>0: SYSERR exception is not generated (initial value). 1: SYSERR exception is generated.</p>
5	SEG_ CONT SEGE	<p>Reserved area access notification enable</p> <p>This bit is used to set the behavior in response to attempted CPU access to data in the reserved area (undefined area).</p> <p>0: SYSERR exception is not generated (initial value). 1: SYSERR exception is generated.</p> <p>Note The reserved area (undefined area) in the address range FFFF 0000_H to FFFF 4FFF_H is for use in future expansion. The user is unable to use this area. A system error will occur if access is attempted.</p>
4	SEG_ CONT RAME	<p>CPU on-chip RAM area error notification enable</p> <p>This bit is used to set the behavior when CPU access to data in the on-chip RAM area leads to an uncorrectable error.</p> <p>0: SYSERR exception is not generated (initial value). 1: SYSERR exception is generated.</p>
2	SEG_ CONT EXTE	<p>EXT area error notification enable</p> <p>This bit is used to set the behavior when CPU access to data in data-flash memory or peripheral I/O leads to the following errors.</p> <ul style="list-style-type: none"> • An error indicated by data-flash memory at the time the memory is read (the error occurs due to the execution of 8- and 32-bit loading, i.e. ld.b and ld.w, from the data-flash area). • Access to peripheral I/O causes an undefined area access error (UAA) or access time out (ATO) to be generated. The error is specified in the peripheral I/O bus PSELG control register (APC). <p>0: SYSERR exception is not generated (initial value). 1: SYSERR exception is generated.</p>
1	SEG_ CONT FCHE	<p>Code flash error notification enable</p> <p>This bit is used to set the behavior when CPU access to data in the code-flash area leads to an uncorrectable ECC error.</p> <p>0: SYSERR exception is not generated (initial value). 1: SYSERR exception is generated.</p>

Caution When a bit is set to 1, a SYSERR exception is generated when a corresponding error occurs. When a bit is set to 0, the error flag corresponding to the error source is set, but a SYSERR exception is not generated.

(2) SEG_FLAG – System Error Flag Register (SEG_FLAG, SEG_FLAGL)

This register is used to store results of the detection of system errors. When a system error is detected, the flag corresponding to the error source is set to 1. Setting flags by directly writing to the register is also possible, providing a way to intentionally generate SYSERR exceptions. A flag is cleared by reading it as 1 and then writing 0 to it. Even when 0 is later written to a flag that was read as 0, the flags will still be set to reflect any errors that occurred between the reading and writing.

Access SEG_FLAG is readable/writable in 16-bit units.

SEG_FLAGL consists of the 8 lower-order bits of SEG_FLAG and is readable/writable in 8- and 1-bit units.

Address FFFF 64B2_H

Initial value 0000_H

	15	14	13	12	11	10	9	8
SEG_FLAG	0	0	0	0	0	0	0	0
	R	R	R	R	R	R	R	R
	7	6	5	4	3	2	1	0
(SEG_FLAGL)	SEG_FLAG DMAF	0	SEG_FLAG SEGF	SEG_FLAG RAMF	0	SEG_FLAG EXTF	SEG_FLAG FCHF	0
	R/W	R	R/W	R/W	R	R/W	R/W	R

Table 3-10 SEG_FLAG Register

Bit Position	Bit Name	Function
7	SEG_FLAG_DMAF	<p>DMA error flag</p> <p>This flag is set when DMA access leads to the following errors.</p> <ul style="list-style-type: none"> • Uncorrectable error generated from flash ROM in response to attempted access to data in the code-flash area • Uncorrectable error in response to access to data in the on-chip RAM area • Access to the reserved area (undefined area) <p>0: DMA error is not generated 1: DMA error is generated</p>
5	SEG_FLAG_SEGF	<p>Reserved area error flag</p> <p>This flag is set in response to attempted CPU access to data in the reserved area (undefined area).</p> <p>0: Error in the reserved area is not generated 1: Error in the reserved area is generated</p> <p>Note The reserved area (undefined area) in the address range FFFF 0000_H to FFFF 4FFF_H is for use in future expansion. The user is unable to use this area. A system error will occur if access is attempted.</p>
4	SEG_FLAG_RAMF	<p>CPU on-chip RAM area error flag</p> <p>This flag is set when CPU access to data in the on-chip RAM area leads to an uncorrectable ECC error.</p> <p>0: Error in the on-chip RAM area is not generated 1: Error in the on-chip RAM area is generated</p>
2	SEG_FLAG_EXTF	<p>EXT area error flag</p> <p>This flag is set when CPU access to data in data-flash memory or peripheral I/O area leads to the following errors.</p> <ul style="list-style-type: none"> • An error indicated by data-flash memory at the time the memory is read (the error occurs due to the execution of 8- and 32-bit loading, i.e. ld.b and ld.w, from the data-flash area). • Access to peripheral I/O causes an undefined area access error (UAA) or access time out (ATO) to be generated. The error is specified in the peripheral I/O bus PSELG control register (APC). <p>0: Error in the EXT area is not generated 1: Error in the EXT area is generated</p>
1	SEG_FLAG_FCHF	<p>Code flash error flag</p> <p>This flag is set when CPU access to data in the code-flash area leads to an uncorrectable ECC error.</p> <p>0: Flash ROM error is not generated. 1: Flash ROM error is generated.</p>

Section 4 Interrupt Functions

4.1 Features

An event where a specific event forces branching from a currently running program to a different program is called an exception. This section describes the exception processing functions of this product.

Table 4-1 List of Exception Sources

Name	Symbol	Source	Priority	Exception Level
CPU initialization	RESET	Reset input	1	–
Reserved	–	–	2	–
FE level non-maskable interrupt	FENMI	FENMI input	3	FE
System error exception	SYSERR	System error (SYSERR) input*1	4	FE
Peripheral device protection exception	PPI	Peripheral device protection violation	5	FE
Timing supervision exception	TSI	Timing supervision violation	6	FE
FE level maskable interrupt	FEINT	FEINT input	7	FE
Reserved	–	–	8	–
EI level maskable interrupt	EIINT	EIINT input	9	EI
Reserved	–	–	10	–
Execution protection exception	MIP	Execution protection violation	11	FE
Memory error exception	MEP	Instruction access error input*2	12	FE
Data protection exception	MDP	Data protection violation	13	FE
Reserved	–	–		–
Coprocessor unusable exception	UCPOP	Coprocessor instruction		FE
Reserved instruction exception	RIEX	Reserved instruction		FE
Reserved	–	–		–
FE level software exception	FETRAPEX	FETRAP instruction (vector = 1 _H to F _H)		FE
EI level software exception	EITRAP0	TRAP0n instruction (vector = 00 _H to 0F _H)		EI
EI level software exception	EITRAP1	TRAP1n instruction (vector = 10 _H to 1F _H)		EI
System call exception	SYSALLEX	SYSCALL instruction (vector = 00 _H to FF _H)	EI	

Note 1. Refer to Section 3.7, System Error Notification Function.

Note 2. An instruction-access error is generated at the point where instruction fetching for the execution of an instruction includes an address where an error is actually generated. Listed below are the error sources.

- Code flash ECC error
- On-chip RAM ECC error
- Reserved area error (access to an address in the range FFFF0000_H to FFFF4FFF_H)

The following three exceptions from Table 4-1 are called interrupts, and are thus described in this section. All other exceptions and their handling are described in the V850E2M Architecture Manual (R01US0001E).

- FE level non-maskable interrupt (FENMI): One source
(generating factors: INTCME, INTWDTA0NMI, or INTCLMA1, INTCLMA2)
 - Resume disabled, recover disabled* (for error report)

- FE level maskable interrupt (FEINT): One source
(generating factors: INTISG pin or NMI pin)
 - Resume enabled, recover enabled*
 - Highest priority interrupt (except FENMI)

- EI level maskable interrupt (EIINT): 131 sources
 - Resume enabled, recover enabled.*
 - Interrupt masking can be specified per interrupt channel.
 - 16 interrupt priority levels can be specified for each interrupt channel
 - In this section the EIINT that corresponds to interrupt channel n is indicated by EIINTn.

Note * Resume:Indicates whether execution restart from the last position at which program execution was interrupted is possible.

Recover:Indicates whether recovery to the processor status (status of processor resources including general-purpose registers and system registers) at the time of program execution interruption is possible.

These interrupt sources are listed in Table 4-2.

4.2 List of Interrupt Sources

Table 4-2 List of Interrupt Sources (1/8)

Level	Symbol	Symbol for Source of Interrupt	Generating Condition or Factor	Generating Unit	Default Priority	Exception Code	Handler Offset*1	PC Value on Return	Instruction for Return	Interrupt Control Register	
										Symbol	Address
FE	FENMI	FENMI	Interrupt occurred with INTCME, INTWDTA0NMI, or INTCLMA1-2.*2	-	-	00000020H	+0020H	-	-	FNC	FFFF 645C
FE	FEINT	FEINT	SGA interrupt (INTISG)*3 or NMI pin interrupt	-	-	00000010H	+0010H	currentPC	FERET	FIC	FFFF 645E
EI	EIINT0	INTCME*4	CPU comparison error	Safety	0	00000080H	+0080H	currentPC	EIRET	ICGME	FFFF 6000
EI	EIINT1	INTISG*4	SGA interrupt	Safety	1	00000090H	+0090H	currentPC	EIRET	ICISG	FFFF 6002
EI	EIINT2	INTWDTA0NMI*4	NMI output from watchdog	WDTA0	2	000000A0H	+00A0H	currentPC	EIRET	ICWDTA0NMI	FFFF 6004
EI	EIINT3	INTWDTA0	WDTA0 75% interrupt	WDTA0	3	000000B0H	+00B0H	currentPC	EIRET	ICWDTA0	FFFF 6006
EI	EIINT4	Reserved				000000C0H	+00C0H	currentPC	EIRET		
EI	EIINT5	INTCLMA1*4	Detection of CLMA1 abnormality	CLMA1	5	000000D0H	+00D0H	currentPC	EIRET	ICCLMA1	FFFF 600A
EI	EIINT6	INTCLMA2*4	Detection of CLMA2 abnormality	CLMA2	6	000000E0H	+00E0H	currentPC	EIRET	ICCLMA2	FFFF 600C
EI	EIINT7	INTECCCFEC	Detection or correction of an ECC error in code flash	Safety	7	000000F0H	+00F0H	currentPC	EIRET	ICECCCFEC	FFFF 600E
EI	EIINT8	INTECCLED	Detection of an ECC error in on-chip RAM	Safety	8	00000100H	+0100H	currentPC	EIRET	ICECCLED	FFFF 6010
EI	EIINT9	INTECCREC	Detection or correction of an ECC error in on-chip RAM	Safety	9	00000110H	+0110H	currentPC	EIRET	ICECCREC	FFFF 6012
EI	EIINT10	INTECCDRED2	Detection, due to cache flushing, of an ECC error in RAM (level 2)	Safety	10	00000120H	+0120H	currentPC	EIRET	ICECCDRED2	FFFF 6014
EI	EIINT11	INTECCCTRED2	Detection, due to cache flushing, of an ECC error in TAG (level 2)	Safety	11	00000130H	+0130H	currentPC	EIRET	ICECCCTRED2	FFFF 6016
EI	EIINT12	INTECCCDRED1	Detection, due to cache flushing, of an ECC error in RAM (level 1)	Safety	12	00000140H	+0140H	currentPC	EIRET	ICECCCDRED1	FFFF 6018
EI	EIINT13	INTECCCTRED1	Detection, due to cache flushing, of an ECC error in TAG (level 1)	Safety	13	00000150H	+0150H	currentPC	EIRET	ICECCCTRED1	FFFF 601A
EI	EIINT14	Reserved				00000160H	+0160H	currentPC	EIRET		
EI	EIINT15	INTECCCNED	Detection of an ECC error in CAN RAM	Safety	15	00000170H	+0170H	currentPC	EIRET	ICECCCNED	FFFF 601E
EI	EIINT16	INTLVIO	Low voltage detection	LVI	16	00000180H	+0180H	currentPC	EIRET	ICLVIO	FFFF 6020
EI	EIINT17	INTP0	INTP0 edge detection	Port	17	00000190H	+0190H	currentPC	EIRET	ICP0	FFFF 6022
EI	EIINT18	INTP1	INTP1 edge detection	Port	18	000001A0H	+01A0H	currentPC	EIRET	ICP1	FFFF 6024
EI	EIINT19	INTP2	INTP2 edge detection	Port	19	000001B0H	+01B0H	currentPC	EIRET	ICP2	FFFF 6026
EI	EIINT20	INTP3	INTP3 edge detection	Port	20	000001C0H	+01C0H	currentPC	EIRET	ICP3	FFFF 6028
EI	EIINT21	INTP4	INTP4 edge detection	Port	21	000001D0H	+01D0H	currentPC	EIRET	ICP4	FFFF 602A

Table 4-2 List of Interrupt Sources (2/8)

Level	Symbol	Symbol for Source of Interrupt	Generating Condition or Factor	Generating Unit	Default Priority	Exception Code	Handler Offset*1	PC Value on Return	Instruction for Return	Interrupt Control Register	
										Symbol	Address
EI	EIINT22	INTP5	INTP5 edge detection	Port	22	000001E0H	+01E0H	currentPC	EIRET	ICP5	FFFF 602C
EI	EIINT23	INTP6	INTP6 edge detection	Port	23	000001F0H	+01F0H	currentPC	EIRET	ICP6	FFFF 602E
EI	EIINT24	INTP7	INTP7 edge detection	Port	24	00000200H	+0200H	currentPC	EIRET	ICP7	FFFF 6030
EI	EIINT25	INTP8	INTP8 edge detection	Port	25	00000210H	+0210H	currentPC	EIRET	ICP8	FFFF 6032
EI	EIINT26	INTP9	INTP9 edge detection	Port	26	00000220H	+0220H	currentPC	EIRET	ICP9	FFFF 6034
EI	EIINT27	Reserved				00000230H	+0230H	currentPC	EIRET		
EI	EIINT28	INTDMA0	DMA transfer completed 0	DMA	28	00000240H	+0240H	currentPC	EIRET	ICDMA0	FFFF 6038
EI	EIINT29	INTDMACT0	DMA transfer count matched 0	DMA	29	00000250H	+0250H	currentPC	EIRET	ICDMACT0	FFFF 603A
EI	EIINT30	INTDMA1	DMA transfer completed 1	DMA	30	00000260H	+0260H	currentPC	EIRET	ICDMA1	FFFF 603C
EI	EIINT31	INTDMACT1	DMA transfer count matched 1	DMA	31	00000270H	+0270H	currentPC	EIRET	ICDMACT1	FFFF 603E
EI	EIINT32	INTDMA2	DMA transfer completed 2	DMA	32	00000280H	+0280H	currentPC	EIRET	ICDMA2	FFFF 6040
EI	EIINT33	INTDMACT2	DMA transfer count matched 2	DMA	33	00000290H	+0290H	currentPC	EIRET	ICDMACT2	FFFF 6042
EI	EIINT34	INTDMA3	DMA transfer completed 3	DMA	34	000002A0H	+02A0H	currentPC	EIRET	ICDMA3	FFFF 6044
EI	EIINT35	INTDMACT3	DMA transfer count matched 3	DMA	35	000002B0H	+02B0H	currentPC	EIRET	ICDMACT3	FFFF 6046
EI	EIINT36	INTDMA4	DMA transfer completed 4	DMA	36	000002C0H	+02C0H	currentPC	EIRET	ICDMA4	FFFF 6048
EI	EIINT37	INTDMACT4	DMA transfer count matched 4	DMA	37	000002D0H	+02D0H	currentPC	EIRET	ICDMACT4	FFFF 604A
EI	EIINT38	INTDMA5	DMA transfer completed 5	DMA	38	000002E0H	+02E0H	currentPC	EIRET	ICDMA5	FFFF 604C
EI	EIINT39	INTDMACT5	DMA transfer count matched 5	DMA	39	000002F0H	+02F0H	currentPC	EIRET	ICDMACT5	FFFF 604E
EI	EIINT40	INTDMA6	DMA transfer completed 6	DMA	40	00000300H	+0300H	currentPC	EIRET	ICDMA6	FFFF 6050
EI	EIINT41	INTDMACT6	DMA transfer count matched 6	DMA	41	00000310H	+0310H	currentPC	EIRET	ICDMACT6	FFFF 6052
EI	EIINT42	INTDMA7	DMA transfer completed 7	DMA	42	00000320H	+0320H	currentPC	EIRET	ICDMA7	FFFF 6054
EI	EIINT43	INTDMACT7	DMA transfer count matched 7	DMA	43	00000330H	+0330H	currentPC	EIRET	ICDMACT7	FFFF 6056
EI	EIINT44	INTOSTM0	OST0 interrupt signal	OSTM0	44	00000340H	+0340H	currentPC	EIRET	ICOSTM0	FFFF 6058
EI	EIINT45	INTOSTM1	OST1 interrupt signal	OSTM1	45	00000350H	+0350H	currentPC	EIRET	ICOSTM1	FFFF 605A
EI	EIINT46	INTTAUJ0I0	TAUJ0 CH0 interrupt signal	TAUJ0	46	00000360H	+0360H	currentPC	EIRET	ICTAUJ0I0	FFFF 605C
EI	EIINT47	INTTAUJ0I1	TAUJ0 CH1 interrupt signal	TAUJ0	47	00000370H	+0370H	currentPC	EIRET	ICTAUJ0I1	FFFF 605E
EI	EIINT48	INTTAUJ0I2	TAUJ0 CH2 interrupt signal	TAUJ0	48	00000380H	+0380H	currentPC	EIRET	ICTAUJ0I2	FFFF 6060
EI	EIINT49	INTTAUJ0I3	TAUJ0 CH3 interrupt signal	TAUJ0	49	00000390H	+0390H	currentPC	EIRET	ICTAUJ0I3	FFFF 6062
EI	EIINT50	Reserved				000003A0H	+03A0H	currentPC	EIRET		
EI	EIINT51	Reserved				000003B0H	+03B0H	currentPC	EIRET		
EI	EIINT52	Reserved				000003C0H	+03C0H	currentPC	EIRET		

Table 4-2 List of Interrupt Sources (3/8)

Level	Symbol	Symbol for Source of Interrupt	Generating Condition or Factor	Generating Unit	Default Priority	Exception Code	Handler Offset*1	PC Value on Return	Instruction for Return	Interrupt Control Register	
										Symbol	Address
EI	EIINT53	Reserved				000003D0H	+03D0H	currentPC	EIRET		
EI	EIINT54	INTTAUB010	TAUB0 CH0 interrupt signal	TAUB0	54	000003E0H	+03E0H	currentPC	EIRET	ICTAUB010	FFFF 606C
EI	EIINT55	INTTAUB011	TAUB0 CH1 interrupt signal	TAUB0	55	000003F0H	+03F0H	currentPC	EIRET	ICTAUB011	FFFF 606E
EI	EIINT56	INTTAUB012	TAUB0 CH2 interrupt signal	TAUB0	56	00000400H	+0400H	currentPC	EIRET	ICTAUB012	FFFF 6070
EI	EIINT57	INTTAUB013	TAUB0 CH3 interrupt signal	TAUB0	57	00000410H	+0410H	currentPC	EIRET	ICTAUB013	FFFF 6072
EI	EIINT58	INTTAUB014	TAUB0 CH4 interrupt signal	TAUB0	58	00000420H	+0420H	currentPC	EIRET	ICTAUB014	FFFF 6074
EI	EIINT59	INTTAUB015	TAUB0 CH5 interrupt signal	TAUB0	59	00000430H	+0430H	currentPC	EIRET	ICTAUB015	FFFF 6076
EI	EIINT60	INTTAUB016	TAUB0 CH6 interrupt signal	TAUB0	60	00000440H	+0440H	currentPC	EIRET	ICTAUB016	FFFF 6078
EI	EIINT61	INTTAUB017	TAUB0 CH7 interrupt signal	TAUB0	61	00000450H	+0450H	currentPC	EIRET	ICTAUB017	FFFF 607A
EI	EIINT62	INTTAUB018	TAUB0 CH8 interrupt signal	TAUB0	62	00000460H	+0460H	currentPC	EIRET	ICTAUB018	FFFF 607C
EI	EIINT63	INTTAUB019	TAUB0 CH9 interrupt signal	TAUB0	63	00000470H	+0470H	currentPC	EIRET	ICTAUB019	FFFF 607E
EI	EIINT64	INTTAUB0110	TAUB0 CH10 interrupt signal	TAUB0	64	00000480H	+0480H	currentPC	EIRET	ICTAUB0110	FFFF 6080
EI	EIINT65	INTTAUB0111	TAUB0 CH11 interrupt signal	TAUB0	65	00000490H	+0490H	currentPC	EIRET	ICTAUB0111	FFFF 6082
EI	EIINT66	INTTAUB0112	TAUB0 CH12 interrupt signal	TAUB0	66	000004A0H	+04A0H	currentPC	EIRET	ICTAUB0112	FFFF 6084
EI	EIINT67	INTTAUB0113	TAUB0 CH13 interrupt signal	TAUB0	67	000004B0H	+04B0H	currentPC	EIRET	ICTAUB0113	FFFF 6086
EI	EIINT68	INTTAUB0114	TAUB0 CH14 interrupt signal	TAUB0	68	000004C0H	+04C0H	currentPC	EIRET	ICTAUB0114	FFFF 6088
EI	EIINT69	INTTAUB0115	TAUB0 CH15 interrupt signal	TAUB0	69	000004D0H	+04D0H	currentPC	EIRET	ICTAUB0115	FFFF 608A
EI	EIINT70	Reserved				000004E0H	+04E0H	currentPC	EIRET		
EI	EIINT71	Reserved				000004F0H	+04F0H	currentPC	EIRET		
EI	EIINT72	Reserved				00000500H	+0500H	currentPC	EIRET		
EI	EIINT73	Reserved				00000510H	+0510H	currentPC	EIRET		
EI	EIINT74	Reserved				00000520H	+0520H	currentPC	EIRET		
EI	EIINT75	Reserved				00000530H	+0530H	currentPC	EIRET		
EI	EIINT76	Reserved				00000540H	+0540H	currentPC	EIRET		
EI	EIINT77	Reserved				00000550H	+0550H	currentPC	EIRET		
EI	EIINT78	Reserved				00000560H	+0560H	currentPC	EIRET		
EI	EIINT79	Reserved				00000570H	+0570H	currentPC	EIRET		
EI	EIINT80	Reserved				00000580H	+0580H	currentPC	EIRET		
EI	EIINT81	Reserved				00000590H	+0590H	currentPC	EIRET		
EI	EIINT82	Reserved				000005A0H	+05A0H	currentPC	EIRET		
EI	EIINT83	Reserved				000005B0H	+05B0H	currentPC	EIRET		

Table 4-2 List of Interrupt Sources (4/8)

Level	Symbol	Symbol for Source of Interrupt	Generating Condition or Factor	Generating Unit	Default Priority	Exception Code	Handler Offset*1	PC Value on Return	Instruction for Return	Interrupt Control Register	
										Symbol	Address
EI	EIINT84	Reserved				000005C0H	+05C0H	currentPC	EIRET		
EI	EIINT85	Reserved				000005D0H	+05D0H	currentPC	EIRET		
EI	EIINT86	INTADCA0ERR	ADC error interrupt signal	ADCA0	86	000005E0H	+05E0H	currentPC	EIRET	ICADCA0ERR	FFFF 60AC
EI	EIINT87	INTADCA0I0	ADC conversion completed CG0	ADCA0	87	000005F0H	+05F0H	currentPC	EIRET	ICADCA0I0	FFFF 60AE
EI	EIINT88	INTADCA0I1	ADC conversion completed CG1	ADCA0	88	00000600H	+0600H	currentPC	EIRET	ICADCA0I1	FFFF 60B0
EI	EIINT89	INTADCA0I2	ADC conversion completed CG2	ADCA0	89	00000610H	+0610H	currentPC	EIRET	ICADCA0I2	FFFF 60B2
EI	EIINT90	INTADCA0LLT	Timing of latest conversion by the ADC	ADCA0	90	00000620H	+0620H	currentPC	EIRET	ICADCA0LLT	FFFF 60B4
EI	EIINT91	Reserved				00000630H	+0630H	currentPC	EIRET		
EI	EIINT92	Reserved				00000640H	+0640H	currentPC	EIRET		
EI	EIINT93	Reserved				00000650H	+0650H	currentPC	EIRET		
EI	EIINT94	Reserved				00000660H	+0660H	currentPC	EIRET		
EI	EIINT95	Reserved				00000670H	+0670H	currentPC	EIRET		
EI	EIINT96	Reserved				00000680H	+0680H	currentPC	EIRET		
EI	EIINT97	Reserved				00000690H	+0690H	currentPC	EIRET		
EI	EIINT98	Reserved				000006A0H	+06A0H	currentPC	EIRET		
EI	EIINT99	INTCSIG0IRE	CSIG0 reception error	CSIG0	99	000006B0H	+06B0H	currentPC	EIRET	ICCSIG0IRE	FFFF 60C6
EI	EIINT100	INTCSIG0IR	CSIG0 reception complete	CSIG0	100	000006C0H	+06C0H	currentPC	EIRET	ICCSIG0IR	FFFF 60C8
EI	EIINT101	INTCSIG0IC	CSIG0 communication complete	CSIG0	101	000006D0H	+06D0H	currentPC	EIRET	ICCSIG0IC	FFFF 60CA
EI	EIINT102	INTCSIG1IRE	CSIG1 reception error	CSIG1	102	000006E0H	+06E0H	currentPC	EIRET	ICCSIG1IRE	FFFF 60CC
EI	EIINT103	INTCSIG1IR	CSIG1 reception complete	CSIG1	103	000006F0H	+06F0H	currentPC	EIRET	ICCSIG1IR	FFFF 60CE
EI	EIINT104	INTCSIG1IC	CSIG1 communication complete	CSIG1	104	00000700H	+0700H	currentPC	EIRET	ICCSIG1IC	FFFF 60D0
EI	EIINT105	Reserved				00000710H	+0710H	currentPC	EIRET		
EI	EIINT106	Reserved				00000720H	+0720H	currentPC	EIRET		
EI	EIINT107	Reserved				00000730H	+0730H	currentPC	EIRET		
EI	EIINT108	INTURTH0IS	UARTH0 status interrupt	UARTH0	108	00000740H	+0740H	currentPC	EIRET	ICURTH0IS	FFFF 60D8
EI	EIINT109	INTURTH0IR	UARTH0 reception complete	UARTH0	109	00000750H	+0750H	currentPC	EIRET	ICURTH0IR	FFFF 60DA
EI	EIINT110	INTURTH0IT	UARTH0 transmission complete	UARTH0	110	00000760H	+0760H	currentPC	EIRET	ICURTH0IT	FFFF 60DC
EI	EIINT111	INTURTH1IS	UARTH1 status interrupt	UARTH1	111	00000770H	+0770H	currentPC	EIRET	ICURTH1IS	FFFF 60DE
EI	EIINT112	INTURTH1IR	UARTH1 reception complete	UARTH1	112	00000780H	+0780H	currentPC	EIRET	ICURTH1IR	FFFF 60E0
EI	EIINT113	INTURTH1IT	UARTH1 transmission complete	UARTH1	113	00000790H	+0790H	currentPC	EIRET	ICURTH1IT	FFFF 60E2
EI	EIINT114	Reserved				000007A0H	+07A0H	currentPC	EIRET		

Table 4-2 List of Interrupt Sources (5/8)

Level	Symbol	Symbol for Source of Interrupt	Generating Condition or Factor	Generating Unit	Default Priority	Exception Code	Handler Offset*1	PC Value on Return	Instruction for Return	Interrupt Control Register	
										Symbol	Address
EI	EIINT115	Reserved				000007B0H	+07B0H	currentPC	EIRET		
EI	EIINT116	Reserved				000007C0H	+07C0H	currentPC	EIRET		
EI	EIINT117	INTFCN0ERR	CAN0 error	FCN0	117	000007D0H	+07D0H	currentPC	EIRET	ICFCN0ERR	FFFF 60EA
EI	EIINT118	INTFCN0WUP	CAN0 wake up	FCN0	118	000007E0H	+07E0H	currentPC	EIRET	ICFCN0WUP	FFFF 60EC
EI	EIINT119	INTFCN0REC	CAN0 reception complete	FCN0	119	000007F0H	+07F0H	currentPC	EIRET	ICFCN0REC	FFFF 60EE
EI	EIINT120	INTFCN0TRX	CAN0 transmission complete	FCN0	120	00000800H	+0800H	currentPC	EIRET	ICFCN0TRX	FFFF 60F0
EI	EIINT121	INTFCN1ERR	CAN1 error	FCN1	121	00000810H	+0810H	currentPC	EIRET	ICFCN1ERR	FFFF 60F2
EI	EIINT122	INTFCN1WUP	CAN1 wake up	FCN1	122	00000820H	+0820H	currentPC	EIRET	ICFCN1WUP	FFFF 60F4
EI	EIINT123	INTFCN1REC	CAN1 reception complete	FCN1	123	00000830H	+0830H	currentPC	EIRET	ICFCN1REC	FFFF 60F6
EI	EIINT124	INTFCN1TRX	CAN1 transmission complete	FCN1	124	00000840H	+0840H	currentPC	EIRET	ICFCN1TRX	FFFF 60F8
EI	EIINT125	INTBRG0	BRG interrupt	BRG	125	00000850H	+0850H	currentPC	EIRET	ICBRG0	FFFF 60FA
EI	EIINT126	Reserved				00000860H	+0860H	currentPC	EIRET		
EI	EIINT127	INTFL	Flash programming complete interrupt (code/data)	Code flash/ Data flash	127	00000870H	+0870H	currentPC	EIRET	ICFL	FFFF 60FE
EI	EIINT128	INTSWN ⁵	Nexus software interrupt	Software	128	00000880H	+0880H	currentPC	EIRET	ICSWN	FFFF 6100
EI	EIINT129	INTTSG20100	TSG20 PWM cycle interrupt	TSG20	129	00000890H	+0890H	currentPC	EIRET	ICTSG20100	FFFF 6102
EI	EIINT130	INTTSG20101	TSG20 compare match 1 interrupt	TSG20	130	000008AA0H	+08AA0H	currentPC	EIRET	ICTSG20101	FFFF 6104
EI	EIINT131	INTTSG20102	TSG20 compare match 2 interrupt	TSG20	131	000008B0H	+08B0H	currentPC	EIRET	ICTSG20102	FFFF 6106
EI	EIINT132	INTTSG20103	TSG20 compare match 3 interrupt	TSG20	132	000008C0H	+08C0H	currentPC	EIRET	ICTSG20103	FFFF 6108
EI	EIINT133	INTTSG20104	TSG20 compare match 4 interrupt	TSG20	133	000008D0H	+08D0H	currentPC	EIRET	ICTSG20104	FFFF 610A
EI	EIINT134	INTTSG20105	TSG20 compare match 5 interrupt	TSG20	134	000008E0H	+08E0H	currentPC	EIRET	ICTSG20105	FFFF 610C
EI	EIINT135	INTTSG20106	TSG20 compare match 6 interrupt	TSG20	135	000008F0H	+08F0H	currentPC	EIRET	ICTSG20106	FFFF 610E
EI	EIINT136	INTTSG20107	TSG20 compare match 7 interrupt	TSG20	136	00000900H	+0900H	currentPC	EIRET	ICTSG20107	FFFF 6110
EI	EIINT137	INTTSG20108	TSG20 compare match 8 interrupt	TSG20	137	00000910H	+0910H	currentPC	EIRET	ICTSG20108	FFFF 6112
EI	EIINT138	INTTSG20109	TSG20 compare match 9 interrupt	TSG20	138	00000920H	+0920H	currentPC	EIRET	ICTSG20109	FFFF 6114
EI	EIINT139	INTTSG20110	TSG20 compare match 10 interrupt	TSG20	139	00000930H	+0930H	currentPC	EIRET	ICTSG20110	FFFF 6116
EI	EIINT140	INTTSG20111	TSG20 compare match 11 interrupt	TSG20	140	00000940H	+0940H	currentPC	EIRET	ICTSG20111	FFFF 6118
EI	EIINT141	INTTSG20112	TSG20 compare match 12 interrupt	TSG20	141	00000950H	+0950H	currentPC	EIRET	ICTSG20112	FFFF 611A
EI	EIINT142	INTTSG20IPEK	TSG20 peak interrupt	TSG20	142	00000960H	+0960H	currentPC	EIRET	ICTSG20IPEK	FFFF 611C
EI	EIINT143	INTTSG20VLY	TSG20 valley interrupt	TSG20	143	00000970H	+0970H	currentPC	EIRET	ICTSG20VLY	FFFF 611E
EI	EIINT144	INTTSG20IER	TSG20 error interrupt	TSG20	144	00000980H	+0980H	currentPC	EIRET	ICTSG20IER	FFFF 6120

Table 4-2 List of Interrupt Sources (6/8)

Level	Symbol	Symbol for Source of Interrupt	Generating Condition or Factor	Generating Unit	Default Priority	Exception Code	Handler Offset*1	PC Value on Return	Instruction for Return	Interrupt Control Register	
										Symbol	Address
EI	EIINT145	INTTSG20IWN	TSG20 warning interrupt	TSG20	145	00000990H	+0990H	currentPC	EIRET	ICTSG20IWN	FFFF 6122
EI	EIINT146	Reserved				000009A0H	+09A0H	currentPC	EIRET		
EI	EIINT147	Reserved				000009B0H	+09B0H	currentPC	EIRET		
EI	EIINT148	Reserved				000009C0H	+09C0H	currentPC	EIRET		
EI	EIINT149	Reserved				000009D0H	+09D0H	currentPC	EIRET		
EI	EIINT150	Reserved				000009E0H	+09E0H	currentPC	EIRET		
EI	EIINT151	Reserved				000009F0H	+09F0H	currentPC	EIRET		
EI	EIINT152	Reserved				00000A00H	+0A00H	currentPC	EIRET		
EI	EIINT153	Reserved				00000A10H	+0A10H	currentPC	EIRET		
EI	EIINT154	Reserved				00000A20H	+0A20H	currentPC	EIRET		
EI	EIINT155	Reserved				00000A30H	+0A30H	currentPC	EIRET		
EI	EIINT156	Reserved				00000A40H	+0A40H	currentPC	EIRET		
EI	EIINT157	Reserved				00000A50H	+0A50H	currentPC	EIRET		
EI	EIINT158	Reserved				00000A60H	+0A60H	currentPC	EIRET		
EI	EIINT159	Reserved				00000A70H	+0A70H	currentPC	EIRET		
EI	EIINT160	Reserved				00000A80H	+0A80H	currentPC	EIRET		
EI	EIINT161	Reserved				00000A90H	+0A90H	currentPC	EIRET		
EI	EIINT162	Reserved				00000AA0H	+0AA0H	currentPC	EIRET		
EI	EIINT163	INTENCA0IOV	ENCA0 overflow interrupt	ENCA0	163	00000AB0H	+0AB0H	currentPC	EIRET	ICENCA0IOV	FFFF 6146
EI	EIINT164	INTENCA0I0	ENCA0 capture/compare match 0 interrupt	ENCA0	164	00000AC0H	+0AC0H	currentPC	EIRET	ICENCA0I0	FFFF 6148
EI	EIINT165	INTENCA0I1	ENCA0 capture/compare match 1 interrupt	ENCA0	165	00000AD0H	+0AD0H	currentPC	EIRET	ICENCA0I1	FFFF 614A
EI	EIINT166	INTENCA0IUD	ENCA0 underflow interrupt	ENCA0	166	00000AE0H	+0AE0H	currentPC	EIRET	ICENCA0IUD	FFFF 614C
EI	EIINT167	INTENCA0IEC	ENCA0 encoder clear interrupt	ENCA0	167	00000AF0H	+0AF0H	currentPC	EIRET	ICENCA0IEC	FFFF 614E
EI	EIINT168	Reserved				00000B00H	+0B00H	currentPC	EIRET		
EI	EIINT169	Reserved				00000B10H	+0B10H	currentPC	EIRET		
EI	EIINT170	Reserved				00000B20H	+0B20H	currentPC	EIRET		
EI	EIINT171	Reserved				00000B30H	+0B30H	currentPC	EIRET		
EI	EIINT172	Reserved				00000B40H	+0B40H	currentPC	EIRET		
EI	EIINT173	INTTPBA0IPRD	TPBA0 period-matched detection interrupt	TPB0	173	00000B50H	+0B50H	currentPC	EIRET	ICTPBA0IPRD	FFFF 615A
EI	EIINT174	INTTPBA0IDTY	TPBA0 duty-cycle-matched detection	TPB0	174	00000B60H	+0B60H	currentPC	EIRET	ICTPBA0IDTY	FFFF 615C

Table 4-2 List of Interrupt Sources (7/8)

Level	Symbol	Symbol for Source of Interrupt	Generating Condition or Factor	Generating Unit	Default Priority	Exception Code	Handler Offset*1	PC Value on Return	Instruction for Return	Interrupt Control Register	
										Symbol	Address
EI	EIINT175	INTTPBA0IPAT	TPBA0 number-of-patterns matched detection interrupt	TPB0	175	00000B70h	+0B70h	currentPC	EIRET	ICTPBA0IPAT	FFFF 615E
EI	EIINT176	Reserved					+0B80h	currentPC	EIRET		
EI	EIINT177	Reserved					+0B90h	currentPC	EIRET		
EI	EIINT178	Reserved					+0BA0h	currentPC	EIRET		
EI	EIINT179	Reserved					+0BB0h	currentPC	EIRET		
EI	EIINT180	Reserved					+0BC0h	currentPC	EIRET		
EI	EIINT181	INTTAPA0IPEK0	TAPA0 peak interrupt	TAPA0	181	00000BD0h	+0BD0h	currentPC	EIRET	ICTAPA0IPEK0	FFFF 616A
EI	EIINT182	INTTAPA0IVLY0	TAPA0 valley interrupt	TAPA0	182	00000BE0h	+0BE0h	currentPC	EIRET	ICTAPA0IVLY0	FFFF 616C
EI	EIINT183	Reserved					+0BF0h	currentPC	EIRET		
EI	EIINT184	Reserved					+0C00h	currentPC	EIRET		
EI	EIINT185	Reserved					+0C10h	currentPC	EIRET		
EI	EIINT186	Reserved					+0C20h	currentPC	EIRET		
EI	EIINT187	Reserved					+0C30h	currentPC	EIRET		
EI	EIINT188	Reserved					+0C40h	currentPC	EIRET		
EI	EIINT189	Reserved					+0C50h	currentPC	EIRET		
EI	EIINT190	Reserved					+0C60h	currentPC	EIRET		
EI	EIINT191	Reserved					+0C70h	currentPC	EIRET		
EI	EIINT192	Reserved					+0C80h	currentPC	EIRET		
EI	EIINT193	INTSW0*6	Software interrupt 0	Software	193	00000C90h	+0C90h	currentPC	EIRET	ICSW0	FFFF 6182
EI	EIINT194	INTSW1*6	Software interrupt 1	Software	194	00000CA0h	+0CA0h	currentPC	EIRET	ICSW1	FFFF 6184
EI	EIINT195	INTSW2*6	Software interrupt 2	Software	195	00000CB0h	+0CB0h	currentPC	EIRET	ICSW2	FFFF 6186
EI	EIINT196	INTSW3*6	Software interrupt 3	Software	196	00000CC0h	+0CC0h	currentPC	EIRET	ICSW3	FFFF 6188
EI	EIINT197	INTSW4*6	Software interrupt 4	Software	197	00000CD0h	+0CD0h	currentPC	EIRET	ICSW4	FFFF 618A
EI	EIINT198	INTSW5*6	Software interrupt 5	Software	198	00000CE0h	+0CE0h	currentPC	EIRET	ICSW5	FFFF 618C
EI	EIINT199	INTSW6*6	Software interrupt 6	Software	199	00000CF0h	+0CF0h	currentPC	EIRET	ICSW6	FFFF 618E
EI	EIINT200	INTSW7*6	Software interrupt 7	Software	200	00000D00h	+0D00h	currentPC	EIRET	ICSW7	FFFF 6190
EI	EIINT201	INTSW8*6	Software interrupt 8	Software	201	00000D10h	+0D10h	currentPC	EIRET	ICSW8	FFFF 6192
EI	EIINT202	INTSW9*6	Software interrupt 9	Software	202	00000D20h	+0D20h	currentPC	EIRET	ICSW9	FFFF 6194
EI	EIINT203	Reserved					+0D30h	currentPC	EIRET		
EI	EIINT204	Reserved					+0D40h	currentPC	EIRET		

Table 4-2 List of Interrupt Sources (8/8)

Level	Symbol	Symbol for Source of Interrupt	Generating Condition or Factor	Generating Unit	Default Priority	Exception Code	Handler Offset*1	PC Value on Return	Instruction for Return	Interrupt Control Register	
										Symbol	Address
EI	EIINT205	Reserved				00000D50H	+0D50H	currentPC	EIRET		
EI	EIINT206	Reserved				00000D60H	+0D60H	currentPC	EIRET		
EI	EIINT207	Reserved				00000D70H	+0D70H	currentPC	EIRET		
EI	EIINT208	Reserved				00000D80H	+0D80H	currentPC	EIRET		
EI	EIINT209	Reserved				00000D90H	+0D90H	currentPC	EIRET		
EI	EIINT210	Reserved				00000DA0H	+0DA0H	currentPC	EIRET		
EI	EIINT211	Reserved				00000DB0H	+0DB0H	currentPC	EIRET		
EI	EIINT212	Reserved				00000DC0H	+0DC0H	currentPC	EIRET		
EI	EIINT213	Reserved				00000DD0H	+0DD0H	currentPC	EIRET		
EI	EIINT214	Reserved				00000DE0H	+0DE0H	currentPC	EIRET		
EI	EIINT215	Reserved				00000DF0H	+0DF0H	currentPC	EIRET		
EI	EIINT216	Reserved				00000E00H	+0E00H	currentPC	EIRET		
EI	EIINT217	Reserved				00000E10H	+0E10H	currentPC	EIRET		
EI	EIINT218	Reserved				00000E20H	+0E20H	currentPC	EIRET		
EI	EIINT219	Reserved				00000E30H	+0E30H	currentPC	EIRET		
EI	EIINT220	INTSGACMEDIAG	Compare unit self-diagnostic interrupt	SGA	220	00000E40H	+0E40H	currentPC	EIRET	ICSGACMEDIAG	FFFF61B8
EI	EIINT221	Reserved				00000E50H	+0E50H	currentPC	EIRET		
EI	EIINT222	Reserved				00000E60H	+0E60H	currentPC	EIRET		
EI	EIINT223	Reserved				00000E70H	+0E70H	currentPC	EIRET		

Note 1. The base address is set by the "exception handler address switching function".

Note 2. If the INTCFGB register is set for level output of EI, FENMI interrupts will not be generated.

Note 3. If the INTCFGB register is set for level output of EI, the INTISG interrupt factor will not lead to the generation of FEINT.

Note 4. If the INTCFGB register is set for level output of FE, EI level interrupts will not be generated.

Note 5. With an interrupt INTSWN, only writing 1 to the RFSWN bit in the ICSWNH register by software acts as the interrupt source.

Note 6. With interrupts INTSW0 to INTSW9, only writing 1 to the RFSW[0:9] bits in the ICSW0 to ICSW9 registers by software acts as the interrupt source.

4.3 Interrupt Controller Control Registers

Meaning of xx xx denotes the identifying names of the individual peripheral units.

4.3.1 ICxx: EI Level Interrupt Control Register

An ICxx register is provided for every EI level-maskable interrupt (EIINT) channel, and is used to configure control conditions.

Access Readable/writable in 1-, 8-, or 16-bit units.

However, bit-wise access through SET1, CLR1, NOT1 instructions to bits 15 to 13, bits 11 to 8 and bits 6 to 4 is prohibited.

Address FFFF 6000_H to FFFF 61B9_H

Initial value 008F_H

A reset from any source will initialize the bits.

Caution Do not access ICxx registers that are not listed in Table 4-2.

ICxx	15(7)	14(6)	13(5)	12(4)	11(3)	10(2)	9(1)	8(0)
(ICxxH)	0	0	0	RFxx	0	0	0	0
	R	R	R	R/W	R	R	R	R
	7(7)	6(6)	5(5)	4(4)	3(3)	2(2)	1(1)	0(0)
(ICxxL)	MKxx	0	0	0	P3xx	P2xx	P1xx	P0xx
	R/W	R	R	R	R/W	R/W	R/W	R/W

Bit Position	Bit Name	Function
12	RFxx	This is an interrupt request flag. The RFxx bit is writable from a program. If the RFxx bit is set (to 1), an EI level maskable interrupt n (EINTn) will be generated in the same way as when an interrupt request is received. 0: No interrupt request is made (initial value). 1: Interrupt request is made.
7	MKxx	This is an interrupt mask bit. Setting the MKxx bit masks interrupt requests set in the interrupt request flag (RFxx), i.e. it may be used to obstruct interrupt requests from the given channel to the CPU core. If the MKxx bit is set for a channel, the ICSR.PMF bit will not hold indications of interrupts for that channel. The MKxx bit does not mask input from an interrupt input pin, so the interrupt request flag still gets set even if the MKxx bit is set. The setting of this bit also reflects the setting in the interrupt mask register (IMR). 0: Enables interrupt handling. 1: Prohibits interrupt handling (initial value).
3 to 0	P3xx to P0xx	These bits specify the interrupt priority as one of 16 levels, with 0 as the highest and 15 as the lowest. When multiple EI level-interrupt requests are made simultaneously, the interrupt from the source with the highest priority setting in these bits is selected and conveyed to the CPU core. When P3xx to P0xx bits for different sources specify the same priority level, the source with the lower channel number takes priority. This order is fixed.

Table 4-3 Addresses and Bits of the Interrupt Control Registers (1/6)

Register	Address	Bit							
		7	6	5	4	3	2	1	0
ICCMEL	FFFF6000 _H	MKCME	0	0	0	P3CME	P2CME	P1CME	P0CME
ICCMEH	FFFF6001 _H	0	0	0	RFCME	0	0	0	0
ICISGL	FFFF6002 _H	MKISG	0	0	0	P3ISG	P2ISG	P1ISG	P0ISG
ICISGH	FFFF6003 _H	0	0	0	RFISG	0	0	0	0
ICWDTA0NMIL	FFFF6004 _H	MKWDTA0NMI	0	0	0	P3WDTA0NMI	P2WDTA0NMI	P1WDTA0NMI	P0WDTA0NMI
ICWDTA0NMIH	FFFF6005 _H	0	0	0	RFWDTA0NMI	0	0	0	0
ICWDTA0L	FFFF6006 _H	MKWDTA0	0	0	0	P3WDTA0	P2WDTA0	P1WDTA0	P0WDTA0
ICWDTA0H	FFFF6007 _H	0	0	0	RFWDTA0	0	0	0	0
ICCLMA1L	FFFF600A _H	MKCLMA1	0	0	0	P3CLMA1	P2CLMA1	P1CLMA1	P0CLMA1
ICCLMA1H	FFFF600B _H	0	0	0	RFCLMA1	0	0	0	0
ICCLMA2L	FFFF600C _H	MKCLMA2	0	0	0	P3CLMA2	P2CLMA2	P1CLMA2	P0CLMA2
ICCLMA2H	FFFF600D _H	0	0	0	RFCLMA2	0	0	0	0
ICECCCFECL	FFFF600E _H	MKECCCFEC	0	0	0	P3ECCCFEC	P2ECCCFEC	P1ECCCFEC	P0ECCCFEC
ICECCCFECH	FFFF600F _H	0	0	0	RFCCCFEC	0	0	0	0
ICECCCLREDL	FFFF6010 _H	MKECCCLRED	0	0	0	P3ECCCLRED	P2ECCCLRED	P1ECCCLRED	P0ECCCLRED
ICECCCLREDH	FFFF6011 _H	0	0	0	RFCCCLRED	0	0	0	0
ICECCCLRECL	FFFF6012 _H	MKECCCLREC	0	0	0	P3ECCCLREC	P2ECCCLREC	P1ECCCLREC	P0ECCCLREC
ICECCCLRECH	FFFF6013 _H	0	0	0	RFCCCLREC	0	0	0	0
ICECCCDRED2L	FFFF6014 _H	MKECCCDRED2	0	0	0	P3ECCCDRED2	P2ECCCDRED2	P1ECCCDRED2	P0ECCCDRED2
ICECCCDRED2H	FFFF6015 _H	0	0	0	RFCCCDRED2	0	0	0	0
ICECCCTRED2L	FFFF6016 _H	MKECCCTRED2	0	0	0	P3ECCCTRED2	P2ECCCTRED2	P1ECCCTRED2	P0ECCCTRED2
ICECCCTRED2H	FFFF6017 _H	0	0	0	RFCCCTRED2	0	0	0	0
ICECCCDRED1L	FFFF6018 _H	MKECCCDRED1	0	0	0	P3ECCCDRED1	P2ECCCDRED1	P1ECCCDRED1	P0ECCCDRED1
ICECCCDRED1H	FFFF6019 _H	0	0	0	RFCCCDRED1	0	0	0	0
ICECCCTRED1L	FFFF601A _H	MKECCCTRED1	0	0	0	P3ECCCTRED1	P2ECCCTRED1	P1ECCCTRED1	P0ECCCTRED1
ICECCCTRED1H	FFFF601B _H	0	0	0	RFCCCTRED1	0	0	0	0
ICECCCNEDL	FFFF601E _H	MKECCCNED	0	0	0	P3ECCCNED	P2ECCCNED	P1ECCCNED	P0ECCCNED
ICECCCNEDH	FFFF601F _H	0	0	0	RFCCCNED	0	0	0	0
ICLV10L	FFFF6020 _H	MKLV10	0	0	0	P3LV10	P2LV10	P1LV10	P0LV10
ICLV10H	FFFF6021 _H	0	0	0	RFLV10	0	0	0	0
ICP0L	FFFF6022 _H	MKP0	0	0	0	P3P0	P2P0	P1P0	P0P0
ICP0H	FFFF6023 _H	0	0	0	RFP0	0	0	0	0
ICP1L	FFFF6024 _H	MKP1	0	0	0	P3P1	P2P1	P1P1	P0P1
ICP1H	FFFF6025 _H	0	0	0	RFP1	0	0	0	0
ICP2L	FFFF6026 _H	MKP2	0	0	0	P3P2	P2P2	P1P2	P0P2
ICP2H	FFFF6027 _H	0	0	0	RFP2	0	0	0	0
ICP3L	FFFF6028 _H	MKP3	0	0	0	P3P3	P2P3	P1P3	P0P3
ICP3H	FFFF6029 _H	0	0	0	RFP3	0	0	0	0
ICP4L	FFFF602A _H	MKP4	0	0	0	P3P4	P2P4	P1P4	P0P4
ICP4H	FFFF602B _H	0	0	0	RFP4	0	0	0	0
ICP5L	FFFF602C _H	MKP5	0	0	0	P3P5	P2P5	P1P5	P0P5
ICP5H	FFFF602D _H	0	0	0	RFP5	0	0	0	0
ICP6L	FFFF602E _H	MKP6	0	0	0	P3P6	P2P6	P1P6	P0P6
ICP6H	FFFF602F _H	0	0	0	RFP6	0	0	0	0
ICP7L	FFFF6030 _H	MKP7	0	0	0	P3P7	P2P7	P1P7	P0P7
ICP7H	FFFF6031 _H	0	0	0	RFP7	0	0	0	0

Table 4-3 Addresses and Bits of the Interrupt Control Registers (2/6)

Register	Address	Bit							
		7	6	5	4	3	2	1	0
ICP8L	FFFF6032 _H	MKP8	0	0	0	P3P8	P2P8	P1P8	P0P8
ICP8H	FFFF6033 _H	0	0	0	RFP8	0	0	0	0
ICP9L	FFFF6034 _H	MKP9	0	0	0	P3P9	P2P9	P1P9	P0P9
ICP9H	FFFF6035 _H	0	0	0	RFP9	0	0	0	0
ICDMA0L	FFFF6038 _H	MKDMA0	0	0	0	P3DMA0	P2DMA0	P1DMA0	P0DMA0
ICDMA0H	FFFF6039 _H	0	0	0	RFDMA0	0	0	0	0
ICDMACT0L	FFFF603A _H	MKDMACT0	0	0	0	P3DMACT0	P2DMACT0	P1DMACT0	P0DMACT0
ICDMACT0H	FFFF603B _H	0	0	0	RFDMACT0	0	0	0	0
ICDMA1L	FFFF603C _H	MKDMA1	0	0	0	P3DMA1	P2DMA1	P1DMA1	P0DMA1
ICDMA1H	FFFF603D _H	0	0	0	RFDMA1	0	0	0	0
ICDMACT1L	FFFF603E _H	MKDMACT1	0	0	0	P3DMACT1	P2DMACT1	P1DMACT1	P0DMACT1
ICDMACT1H	FFFF603F _H	0	0	0	RFDMACT1	0	0	0	0
ICDMA2L	FFFF6040 _H	MKDMA2	0	0	0	P3DMA2	P2DMA2	P1DMA2	P0DMA2
ICDMA2H	FFFF6041 _H	0	0	0	RFDMA2	0	0	0	0
ICDMACT2L	FFFF6042 _H	MKDMACT2	0	0	0	P3DMACT2	P2DMACT2	P1DMACT2	P0DMACT2
ICDMACT2H	FFFF6043 _H	0	0	0	RFDMACT2	0	0	0	0
ICDMA3L	FFFF6044 _H	MKDMA3	0	0	0	P3DMA3	P2DMA3	P1DMA3	P0DMA3
ICDMA3H	FFFF6045 _H	0	0	0	RFDMA3	0	0	0	0
ICDMACT3L	FFFF6046 _H	MKDMACT3	0	0	0	P3DMACT3	P2DMACT3	P1DMACT3	P0DMACT3
ICDMACT3H	FFFF6047 _H	0	0	0	RFDMACT3	0	0	0	0
ICDMA4L	FFFF6048 _H	MKDMA4	0	0	0	P3DMA4	P2DMA4	P1DMA4	P0DMA4
ICDMA4H	FFFF6049 _H	0	0	0	RFDMA4	0	0	0	0
ICDMACT4L	FFFF604A _H	MKDMACT4	0	0	0	P3DMACT4	P2DMACT4	P1DMACT4	P0DMACT4
ICDMACT4H	FFFF604B _H	0	0	0	RFDMACT4	0	0	0	0
ICDMA5L	FFFF604C _H	MKDMA5	0	0	0	P3DMA5	P2DMA5	P1DMA5	P0DMA5
ICDMA5H	FFFF604D _H	0	0	0	RFDMA5	0	0	0	0
ICDMACT5L	FFFF604E _H	MKDMACT5	0	0	0	P3DMACT5	P2DMACT5	P1DMACT5	P0DMACT5
ICDMACT5H	FFFF604F _H	0	0	0	RFDMACT5	0	0	0	0
ICDMA6L	FFFF6050 _H	MKDMA6	0	0	0	P3DMA6	P2DMA6	P1DMA6	P0DMA6
ICDMA6H	FFFF6051 _H	0	0	0	RFDMA6	0	0	0	0
ICDMACT6L	FFFF6052 _H	MKDMACT6	0	0	0	P3DMACT6	P2DMACT6	P1DMACT6	P0DMACT6
ICDMACT6H	FFFF6053 _H	0	0	0	RFDMACT6	0	0	0	0
ICDMA7L	FFFF6054 _H	MKDMA7	0	0	0	P3DMA7	P2DMA7	P1DMA7	P0DMA7
ICDMA7H	FFFF6055 _H	0	0	0	RFDMA7	0	0	0	0
ICDMACT7L	FFFF6056 _H	MKDMACT7	0	0	0	P3DMACT7	P2DMACT7	P1DMACT7	P0DMACT7
ICDMACT7H	FFFF6057 _H	0	0	0	RFDMACT7	0	0	0	0
ICOSTM0L	FFFF6058 _H	MKOSTM0	0	0	0	P3OSTM0	P2OSTM0	P1OSTM0	P0OSTM0
ICOSTM0H	FFFF6059 _H	0	0	0	RFOSTM0	0	0	0	0
ICOSTM1L	FFFF605A _H	MKOSTM1	0	0	0	P3OSTM1	P2OSTM1	P1OSTM1	P0OSTM1
ICOSTM1H	FFFF605B _H	0	0	0	RFOSTM1	0	0	0	0
ICTAUJ0I0L	FFFF605C _H	MKTAUJ0I0	0	0	0	P3TAUJ0I0	P2TAUJ0I0	P1TAUJ0I0	P0TAUJ0I0
ICTAUJ0I0H	FFFF605D _H	0	0	0	RFTAUJ0I0	0	0	0	0
ICTAUJ0I1L	FFFF605E _H	MKTAUJ0I1	0	0	0	P3TAUJ0I1	P2TAUJ0I1	P1TAUJ0I1	P0TAUJ0I1
ICTAUJ0I1H	FFFF605F _H	0	0	0	RFTAUJ0I1	0	0	0	0
ICTAUJ0I2L	FFFF6060 _H	MKTAUJ0I2	0	0	0	P3TAUJ0I2	P2TAUJ0I2	P1TAUJ0I2	P0TAUJ0I2
ICTAUJ0I2H	FFFF6061 _H	0	0	0	RFTAUJ0I2	0	0	0	0

Table 4-3 Addresses and Bits of the Interrupt Control Registers (3/6)

Register	Address	Bit							
		7	6	5	4	3	2	1	0
ICTAUJ0I3L	FFFF6062 _H	MKTAUJ0I3	0	0	0	P3TAUJ0I3	P2TAUJ0I3	P1TAUJ0I3	P0TAUJ0I3
ICTAUJ0I3H	FFFF6063 _H	0	0	0	RFTAUJ0I3	0	0	0	0
ICTAUB0I0L	FFFF606C _H	MKTAUB0I0	0	0	0	P3TAUB0I0	P2TAUB0I0	P1TAUB0I0	P0TAUB0I0
ICTAUB0I0H	FFFF606D _H	0	0	0	RFTAUB0I0	0	0	0	0
ICTAUB0I1L	FFFF606E _H	MKTAUB0I1	0	0	0	P3TAUB0I1	P2TAUB0I1	P1TAUB0I1	P0TAUB0I1
ICTAUB0I1H	FFFF606F _H	0	0	0	RFTAUB0I1	0	0	0	0
ICTAUB0I2L	FFFF6070 _H	MKTAUB0I2	0	0	0	P3TAUB0I2	P2TAUB0I2	P1TAUB0I2	P0TAUB0I2
ICTAUB0I2H	FFFF6071 _H	0	0	0	RFTAUB0I2	0	0	0	0
ICTAUB0I3L	FFFF6072 _H	MKTAUB0I3	0	0	0	P3TAUB0I3	P2TAUB0I3	P1TAUB0I3	P0TAUB0I3
ICTAUB0I3H	FFFF6073 _H	0	0	0	RFTAUB0I3	0	0	0	0
ICTAUB0I4L	FFFF6074 _H	MKTAUB0I4	0	0	0	P3TAUB0I4	P2TAUB0I4	P1TAUB0I4	P0TAUB0I4
ICTAUB0I4H	FFFF6075 _H	0	0	0	RFTAUB0I4	0	0	0	0
ICTAUB0I5L	FFFF6076 _H	MKTAUB0I5	0	0	0	P3TAUB0I5	P2TAUB0I5	P1TAUB0I5	P0TAUB0I5
ICTAUB0I5H	FFFF6077 _H	0	0	0	RFTAUB0I5	0	0	0	0
ICTAUB0I6L	FFFF6078 _H	MKTAUB0I6	0	0	0	P3TAUB0I6	P2TAUB0I6	P1TAUB0I6	P0TAUB0I6
ICTAUB0I6H	FFFF6079 _H	0	0	0	RFTAUB0I6	0	0	0	0
ICTAUB0I7L	FFFF607A _H	MKTAUB0I7	0	0	0	P3TAUB0I7	P2TAUB0I7	P1TAUB0I7	P0TAUB0I7
ICTAUB0I7H	FFFF607B _H	0	0	0	RFTAUB0I7	0	0	0	0
ICTAUB0I8L	FFFF607C _H	MKTAUB0I8	0	0	0	P3TAUB0I8	P2TAUB0I8	P1TAUB0I8	P0TAUB0I8
ICTAUB0I8H	FFFF607D _H	0	0	0	RFTAUB0I8	0	0	0	0
ICTAUB0I9L	FFFF607E _H	MKTAUB0I9	0	0	0	P3TAUB0I9	P2TAUB0I9	P1TAUB0I9	P0TAUB0I9
ICTAUB0I9H	FFFF607F _H	0	0	0	RFTAUB0I9	0	0	0	0
ICTAUB0I10L	FFFF6080 _H	MKTAUB0I10	0	0	0	P3TAUB0I10	P2TAUB0I10	P1TAUB0I10	P0TAUB0I10
ICTAUB0I10H	FFFF6081 _H	0	0	0	RFTAUB0I10	0	0	0	0
ICTAUB0I11L	FFFF6082 _H	MKTAUB0I11	0	0	0	P3TAUB0I11	P2TAUB0I11	P1TAUB0I11	P0TAUB0I11
ICTAUB0I11H	FFFF6083 _H	0	0	0	RFTAUB0I11	0	0	0	0
ICTAUB0I12L	FFFF6084 _H	MKTAUB0I12	0	0	0	P3TAUB0I12	P2TAUB0I12	P1TAUB0I12	P0TAUB0I12
ICTAUB0I12H	FFFF6085 _H	0	0	0	RFTAUB0I12	0	0	0	0
ICTAUB0I13L	FFFF6086 _H	MKTAUB0I13	0	0	0	P3TAUB0I13	P2TAUB0I13	P1TAUB0I13	P0TAUB0I13
ICTAUB0I13H	FFFF6087 _H	0	0	0	RFTAUB0I13	0	0	0	0
ICTAUB0I14L	FFFF6088 _H	MKTAUB0I14	0	0	0	P3TAUB0I14	P2TAUB0I14	P1TAUB0I14	P0TAUB0I14
ICTAUB0I14H	FFFF6089 _H	0	0	0	RFTAUB0I14	0	0	0	0
ICTAUB0I15L	FFFF608A _H	MKTAUB0I15	0	0	0	P3TAUB0I15	P2TAUB0I15	P1TAUB0I15	P0TAUB0I15
ICTAUB0I15H	FFFF608B _H	0	0	0	RFTAUB0I15	0	0	0	0
ICADCA0ERRL	FFFF60AC _H	MKADCA0ERR	0	0	0	P3ADCA0ERR	P2ADCA0ERR	P1ADCA0ERR	P0ADCA0ERR
ICADCA0ERRH	FFFF60AD _H	0	0	0	RFADCA0ERR	0	0	0	0
ICADCA0I0L	FFFF60AE _H	MKADCA0I0	0	0	0	P3ADCA0I0	P2ADCA0I0	P1ADCA0I0	P0ADCA0I0
ICADCA0I0H	FFFF60AF _H	0	0	0	RFADCA0I0	0	0	0	0
ICADCA0I1L	FFFF60B0 _H	MKADCA0I1	0	0	0	P3ADCA0I1	P2ADCA0I1	P1ADCA0I1	P0ADCA0I1
ICADCA0I1H	FFFF60B1 _H	0	0	0	RFADCA0I1	0	0	0	0
ICADCA0I2L	FFFF60B2 _H	MKADCA0I2	0	0	0	P3ADCA0I2	P2ADCA0I2	P1ADCA0I2	P0ADCA0I2
ICADCA0I2H	FFFF60B3 _H	0	0	0	RFADCA0I2	0	0	0	0
ICADCA0LLTL	FFFF60B4 _H	MKADCA0LLT	0	0	0	P3ADCA0LLT	P2ADCA0LLT	P1ADCA0LLT	P0ADCA0LLT
ICADCA0LLTH	FFFF60B5 _H	0	0	0	RFADCA0LLT	0	0	0	0
ICCSIG0IREL	FFFF60C6 _H	MKCSIG0IRE	0	0	0	P3CSIG0IRE	P2CSIG0IRE	P1CSIG0IRE	P0CSIG0IRE
ICCSIG0IREH	FFFF60C7 _H	0	0	0	RFCSIG0IRE	0	0	0	0

Table 4-3 Addresses and Bits of the Interrupt Control Registers (4/6)

Register	Address	Bit							
		7	6	5	4	3	2	1	0
ICCSIG0IRL	FFFF60C8 _H	MKCSIG0IR	0	0	0	P3CSIG0IR	P2CSIG0IR	P1CSIG0IR	P0CSIG0IR
ICCSIG0IRH	FFFF60C9 _H	0	0	0	RFCSIG0IR	0	0	0	0
ICCSIG0ICL	FFFF60CA _H	MKCSIG0IC	0	0	0	P3CSIG0IC	P2CSIG0IC	P1CSIG0IC	P0CSIG0IC
ICCSIG0ICH	FFFF60CB _H	0	0	0	RFCSIG0IC	0	0	0	0
ICCSIG1IREL	FFFF60CC _H	MKCSIG1IRE	0	0	0	P3CSIG1IRE	P2CSIG1IRE	P1CSIG1IRE	P0CSIG1IRE
ICCSIG1IREH	FFFF60CD _H	0	0	0	RFCSIG1IRE	0	0	0	0
ICCSIG1IRL	FFFF60CE _H	MKCSIG1IR	0	0	0	P3CSIG1IR	P2CSIG1IR	P1CSIG1IR	P0CSIG1IR
ICCSIG1IRH	FFFF60CF _H	0	0	0	RFCSIG1IR	0	0	0	0
ICCSIG1ICL	FFFF60D0 _H	MKCSIG1IC	0	0	0	P3CSIG1IC	P2CSIG1IC	P1CSIG1IC	P0CSIG1IC
ICCSIG1ICH	FFFF60D1 _H	0	0	0	RFCSIG1IC	0	0	0	0
ICURTH0ISL	FFFF60D8 _H	MKURTH0IS	0	0	0	P3URTH0IS	P2URTH0IS	P1URTH0IS	P0URTH0IS
ICURTH0ISH	FFFF60D9 _H	0	0	0	RFURTH0IS	0	0	0	0
ICURTH0IRL	FFFF60DA _H	MKURTH0IR	0	0	0	P3URTH0IR	P2URTH0IR	P1URTH0IR	P0URTH0IR
ICURTH0IRH	FFFF60DB _H	0	0	0	RFURTH0IR	0	0	0	0
ICURTH0ITL	FFFF60DC _H	MKURTH0IT	0	0	0	P3URTH0IT	P2URTH0IT	P1URTH0IT	P0URTH0IT
ICURTH0ITH	FFFF60DD _H	0	0	0	RFURTH0IT	0	0	0	0
ICURTH1ISL	FFFF60DE _H	MKURTH1IS	0	0	0	P3URTH1IS	P2URTH1IS	P1URTH1IS	P0URTH1IS
ICURTH1ISH	FFFF60DF _H	0	0	0	RFURTH1IS	0	0	0	0
ICURTH1IRL	FFFF60E0 _H	MKURTH1IR	0	0	0	P3URTH1IR	P2URTH1IR	P1URTH1IR	P0URTH1IR
ICURTH1IRH	FFFF60E1 _H	0	0	0	RFURTH1IR	0	0	0	0
ICURTH1ITL	FFFF60E2 _H	MKURTH1IT	0	0	0	P3URTH1IT	P2URTH1IT	P1URTH1IT	P0URTH1IT
ICURTH1ITH	FFFF60E3 _H	0	0	0	RFURTH1IT	0	0	0	0
ICFCN0ERRL	FFFF60EA _H	MKFCN0ERR	0	0	0	P3FCN0ERR	P2FCN0ERR	P1FCN0ERR	P0FCN0ERR
ICFCN0ERRH	FFFF60EB _H	0	0	0	RFFCN0ERR	0	0	0	0
ICFCN0WUPL	FFFF60EC _H	MKFCN0WUP	0	0	0	P3FCN0WUP	P2FCN0WUP	P1FCN0WUP	P0FCN0WUP
ICFCN0WUPH	FFFF60ED _H	0	0	0	RFFCN0WUP	0	0	0	0
ICFCN0RECL	FFFF60EE _H	MKFCN0REC	0	0	0	P3FCN0REC	P2FCN0REC	P1FCN0REC	P0FCN0REC
ICFCN0RECH	FFFF60EF _H	0	0	0	RFFCN0REC	0	0	0	0
ICFCN0TRXL	FFFF60F0 _H	MKFCN0TRX	0	0	0	P3FCN0TRX	P2FCN0TRX	P1FCN0TRX	P0FCN0TRX
ICFCN0TRXH	FFFF60F1 _H	0	0	0	RFFCN0TRX	0	0	0	0
ICFCN1ERRL	FFFF60F2 _H	MKFCN1ERR	0	0	0	P3FCN1ERR	P2FCN1ERR	P1FCN1ERR	P0FCN1ERR
ICFCN1ERRH	FFFF60F3 _H	0	0	0	RFFCN1ERR	0	0	0	0
ICFCN1WUPL	FFFF60F4 _H	MKFCN1WUP	0	0	0	P3FCN1WUP	P2FCN1WUP	P1FCN1WUP	P0FCN1WUP
ICFCN1WUPH	FFFF60F5 _H	0	0	0	RFFCN1WUP	0	0	0	0
ICFCN1RECL	FFFF60F6 _H	MKFCN1REC	0	0	0	P3FCN1REC	P2FCN1REC	P1FCN1REC	P0FCN1REC
ICFCN1RECH	FFFF60F7 _H	0	0	0	RFFCN1REC	0	0	0	0
ICFCN1TRXL	FFFF60F8 _H	MKFCN1TRX	0	0	0	P3FCN1TRX	P2FCN1TRX	P1FCN1TRX	P0FCN1TRX
ICFCN1TRXH	FFFF60F9 _H	0	0	0	RFFCN1TRX	0	0	0	0
ICBRG0L	FFFF60FA _H	MKBRG0	0	0	0	P3BRG0	P2BRG0	P1BRG0	P0BRG0
ICBRG0H	FFFF60FB _H	0	0	0	RFBRG0	0	0	0	0
ICFL	FFFF60FE _H	MKFL	0	0	0	P3FL	P2FL	P1FL	P0FL
ICFLH	FFFF60FF _H	0	0	0	RFFL	0	0	0	0
ICSWNL	FFFF6100 _H	MKSWN	0	0	0	P3SWN	P2SWN	P1SWN	P0SWN
ICSWNH	FFFF6101 _H	0	0	0	RFSWN	0	0	0	0
ICTSG20I00L	FFFF6102 _H	MKTSG20I00	0	0	0	P3TSG20I00	P2TSG20I00	P1TSG20I00	P0TSG20I00
ICTSG20I00H	FFFF6103 _H	0	0	0	RFTSG20I00	0	0	0	0

Table 4-3 Addresses and Bits of the Interrupt Control Registers (5/6)

Register	Address	Bit							
		7	6	5	4	3	2	1	0
ICTSG20I01L	FFFF6104 _H	MKTSG20I01	0	0	0	P3TSG20I01	P2TSG20I01	P1TSG20I01	P0TSG20I01
ICTSG20I01H	FFFF6105 _H	0	0	0	RFTSG20I01	0	0	0	0
ICTSG20I02L	FFFF6106 _H	MKTSG20I02	0	0	0	P3TSG20I02	P2TSG20I02	P1TSG20I02	P0TSG20I02
ICTSG20I02H	FFFF6107 _H	0	0	0	RFTSG20I02	0	0	0	0
ICTSG20I03L	FFFF6108 _H	MKTSG20I03	0	0	0	P3TSG20I03	P2TSG20I03	P1TSG20I03	P0TSG20I03
ICTSG20I03H	FFFF6109 _H	0	0	0	RFTSG20I03	0	0	0	0
ICTSG20I04L	FFFF610A _H	MKTSG20I04	0	0	0	P3TSG20I04	P2TSG20I04	P1TSG20I04	P0TSG20I04
ICTSG20I04H	FFFF610B _H	0	0	0	RFTSG20I04	0	0	0	0
ICTSG20I05L	FFFF610C _H	MKTSG20I05	0	0	0	P3TSG20I05	P2TSG20I05	P1TSG20I05	P0TSG20I05
ICTSG20I05H	FFFF610D _H	0	0	0	RFTSG20I05	0	0	0	0
ICTSG20I06L	FFFF610E _H	MKTSG20I06	0	0	0	P3TSG20I06	P2TSG20I06	P1TSG20I06	P0TSG20I06
ICTSG20I06H	FFFF610F _H	0	0	0	RFTSG20I06	0	0	0	0
ICTSG20I07L	FFFF6110 _H	MKTSG20I07	0	0	0	P3TSG20I07	P2TSG20I07	P1TSG20I07	P0TSG20I07
ICTSG20I07H	FFFF6111 _H	0	0	0	RFTSG20I07	0	0	0	0
ICTSG20I08L	FFFF6112 _H	MKTSG20I08	0	0	0	P3TSG20I08	P2TSG20I08	P1TSG20I08	P0TSG20I08
ICTSG20I08H	FFFF6113 _H	0	0	0	RFTSG20I08	0	0	0	0
ICTSG20I09L	FFFF6114 _H	MKTSG20I09	0	0	0	P3TSG20I09	P2TSG20I09	P1TSG20I09	P0TSG20I09
ICTSG20I09H	FFFF6115 _H	0	0	0	RFTSG20I09	0	0	0	0
ICTSG20I10L	FFFF6116 _H	MKTSG20I10	0	0	0	P3TSG20I10	P2TSG20I10	P1TSG20I10	P0TSG20I10
ICTSG20I10H	FFFF6117 _H	0	0	0	RFTSG20I10	0	0	0	0
ICTSG20I11L	FFFF6118 _H	MKTSG20I11	0	0	0	P3TSG20I11	P2TSG20I11	P1TSG20I11	P0TSG20I11
ICTSG20I11H	FFFF6119 _H	0	0	0	RFTSG20I11	0	0	0	0
ICTSG20I12L	FFFF611A _H	MKTSG20I12	0	0	0	P3TSG20I12	P2TSG20I12	P1TSG20I12	P0TSG20I12
ICTSG20I12H	FFFF611B _H	0	0	0	RFTSG20I12	0	0	0	0
ICTSG20IPEKL	FFFF611C _H	MKTSG20IPEK	0	0	0	P3TSG20IPEK	P2TSG20IPEK	P1TSG20IPEK	P0TSG20IPEK
ICTSG20IPEKH	FFFF611D _H	0	0	0	RFTSG20IPEK	0	0	0	0
ICTSG20IVLYL	FFFF611E _H	MKTSG20IVLY	0	0	0	P3TSG20IVLY	P2TSG20IVLY	P1TSG20IVLY	P0TSG20IVLY
ICTSG20IVLYH	FFFF611F _H	0	0	0	RFTSG20IVLY	0	0	0	0
ICTSG20IERL	FFFF6120 _H	MKTSG20IER	0	0	0	P3TSG20IER	P2TSG20IER	P1TSG20IER	P0TSG20IER
ICTSG20IERH	FFFF6121 _H	0	0	0	RFTSG20IER	0	0	0	0
ICTSG20IWNL	FFFF6122 _H	MKTSG20IWN	0	0	0	P3TSG20IWN	P2TSG20IWN	P1TSG20IWN	P0TSG20IWN
ICTSG20IWNH	FFFF6123 _H	0	0	0	RFTSG20IWN	0	0	0	0
ICENCA0IOVL	FFFF6146 _H	MKENCA0IOV	0	0	0	P3ENCA0IOV	P2ENCA0IOV	P1ENCA0IOV	P0ENCA0IOV
ICENCA0IOVH	FFFF6147 _H	0	0	0	RFENCA0IOV	0	0	0	0
ICENCA0IOL	FFFF6148 _H	MKENCA0IO	0	0	0	P3ENCA0IO	P2ENCA0IO	P1ENCA0IO	P0ENCA0IO
ICENCA0IOH	FFFF6149 _H	0	0	0	RFENCA0IO	0	0	0	0
ICENCA0I1L	FFFF614A _H	MKENCA0I1	0	0	0	P3ENCA0I1	P2ENCA0I1	P1ENCA0I1	P0ENCA0I1
ICENCA0I1H	FFFF614B _H	0	0	0	RFENCA0I1	0	0	0	0
ICENCA0IUDL	FFFF614C _H	MKENCA0IUD	0	0	0	P3ENCA0IUD	P2ENCA0IUD	P1ENCA0IUD	P0ENCA0IUD
ICENCA0IUDH	FFFF614D _H	0	0	0	RFENCA0IUD	0	0	0	0
ICENCA0IECL	FFFF614E _H	MKENCA0IEC	0	0	0	P3ENCA0IEC	P2ENCA0IEC	P1ENCA0IEC	P0ENCA0IEC
ICENCA0IECH	FFFF614F _H	0	0	0	RFENCA0IEC	0	0	0	0
ICTPBA0IPRDL	FFFF615A _H	MKTPBA0IPRD	0	0	0	P3TPBA0IPRD	P2TPBA0IPRD	P1TPBA0IPRD	P0TPBA0IPRD
ICTPBA0IPRDH	FFFF615B _H	0	0	0	RFTPBA0IPRD	0	0	0	0
ICTPBA0IDTYL	FFFF615C _H	MKTPBA0IDTY	0	0	0	P3TPBA0IDTY	P2TPBA0IDTY	P1TPBA0IDTY	P0TPBA0IDTY
ICTPBA0IDTYH	FFFF615D _H	0	0	0	RFTPBA0IDTY	0	0	0	0

Table 4-3 Addresses and Bits of the Interrupt Control Registers (6/6)

Register	Address	Bit							
		7	6	5	4	3	2	1	0
ICTPBA0IPATL	FFFF615E _H	MKTPBA0IPAT	0	0	0	P3TPBA0IPAT	P2TPBA0IPAT	P1TPBA0IPAT	P0TPBA0IPAT
ICTPBA0IPATH	FFFF615F _H	0	0	0	RFTPBA0IPAT	0	0	0	0
ICTAPA0IPEK0L	FFFF616A _H	MKTAPA0IPEK0	0	0	0	P3TAPA0IPEK0	P2TAPA0IPEK0	P1TAPA0IPEK0	P0TAPA0IPEK0
ICTAPA0IPEK0H	FFFF616B _H	0	0	0	RFTAPA0IPEK0	0	0	0	0
ICTAPA0IVLY0L	FFFF616C _H	MKTAPA0IVLY0	0	0	0	P3TAPA0IVLY0	P2TAPA0IVLY0	P1TAPA0IVLY0	P0TAPA0IVLY0
ICTAPA0IVLY0H	FFFF616D _H	0	0	0	RFTAPA0IVLY0	0	0	0	0
ICSW0L	FFFF6182 _H	MKSW0	0	0	0	P3SW0	P2SW0	P1SW0	P0SW0
ICSW0H	FFFF6183 _H		0	0	RFSW0	0	0	0	0
ICSW1L	FFFF6184 _H	MKSW1	0	0	0	P3SW1	P2SW1	P1SW1	P0SW1
ICSW1H	FFFF6185 _H		0	0	RFSW1	0	0	0	0
ICSW2L	FFFF6186 _H	MKSW2	0	0	0	P3SW2	P2SW2	P1SW2	P0SW2
ICSW2H	FFFF6187 _H		0	0	RFSW2	0	0	0	0
ICSW3L	FFFF6188 _H	MKSW3	0	0	0	P3SW3	P2SW3	P1SW3	P0SW3
ICSW3H	FFFF6189 _H		0	0	RFSW3	0	0	0	0
ICSW4L	FFFF618A _H	MKSW4	0	0	0	P3SW4	P2SW4	P1SW4	P0SW4
ICSW4H	FFFF618B _H		0	0	RFSW4	0	0	0	0
ICSW5L	FFFF618C _H	MKSW5	0	0	0	P3SW5	P2SW5	P1SW5	P0SW5
ICSW5H	FFFF618D _H		0	0	RFSW5	0	0	0	0
ICSW6L	FFFF618E _H	MKSW6	0	0	0	P3SW6	P2SW6	P1SW6	P0SW6
ICSW6H	FFFF618F _H		0	0	RFSW6	0	0	0	0
ICSW7L	FFFF6190 _H	MKSW7	0	0	0	P3SW7	P2SW7	P1SW7	P0SW7
ICSW7H	FFFF6191 _H		0	0	RFSW7	0	0	0	0
ICSW8L	FFFF6192 _H	MKSW8	0	0	0	P3SW8	P2SW8	P1SW8	P0SW8
ICSW8H	FFFF6193 _H		0	0	RFSW8	0	0	0	0
ICSW9L	FFFF6194 _H	MKSW9	0	0	0	P3SW9	P2SW9	P1SW9	P0SW9
ICSW9H	FFFF6195 _H		0	0	RFSW9	0	0	0	0
ICSGACMEDIAGL	FFFF61B8 _H	MKSGACMEDIAG	0	0	0	P3SGACMEDIAG	P2SGACMEDIAG	P1SGACMEDIAG	P0SGACMEDIAG
ICSGACMEDIAGH	FFFF61B9 _H		0	0	RFSGACMEDIAG	0	0	0	0

4.3.2 IMRm (m = 0 to 13): EI Level Interrupt Mask Register

These registers are for aggregating the ICxx.MKxx bits. Bits of the IMRm register reflect settings of the corresponding ICxx.MKxx bits. Corresponding ICxx.MKxx bits also reflect the settings of IMRm registers.

Caution The IMRm.IMRmEIMKn bits for interrupt sources not listed in Table 4-2 must always be set to 1.

(1) EI Level Interrupt Mask Register 0 (IMR0)

Access Readable/writable in 1-, 8-, or 16-bit units. All of the corresponding IMR0EIMK [15:0] bits are updated simultaneously in response to writing in 8- or 16-bit units.

Address FFFF 6400_H

Initial value FFFF_H

A reset from any source will initialize the bits.

IMR0	15(7)	14(6)	13(5)	12(4)	11(3)	10(2)	9(1)	8(0)
(IMR0H)	IMR0EIMK 15	1	IMR0EIMK 13	IMR0EIMK 12	IMR0EIMK 11	IMR0EIMK 10	IMR0EIMK 9	IMR0EIMK 8
	R/W	R	R/W	R/W	R/W	R/W	R/W	R/W
	7(7)	6(6)	5(5)	4(4)	3(3)	2(2)	1(1)	0(0)
(IMR0L)	IMR0EIMK 7	IMR0EIMK 6	IMR0EIMK 5	1	IMR0EIMK 3	IMR0EIMK 2	IMR0EIMK 1	IMR0EIMK 0
	R/W	R/W	R/W	R	R/W	R/W	R/W	R/W

Bit Position	Bit Name	Function
15 to 0	IMR0EIMK15 to IMR0EIMK0	These are mask bits for EI level maskable interrupt (EIINT) channels 0 to 15 (IMR0EIMK15 to IMR0EIMK0 correspond to EIINT15 to EIINT0). 0: Enables interrupt servicing 1: Disables interrupt servicing

(2) EI Level Interrupt Mask Register 1 (IMR1)

Access Readable/writable in 1-, 8-, or 16-bit units. All of the corresponding IMR1EIMK [31:16] bits are updated simultaneously in response to writing in 8- or 16-bit units.

Address FFFF 6402_H

Initial value FFFF_H

A reset from any source will initialize the bits.

IMR1	15(7)	14(6)	13(5)	12(4)	11(3)	10(2)	9(1)	8(0)
(IMR1H)	IMR1EIMK 31	IMR1EIMK 30	IMR1EIMK 29	IMR1EIMK 28	1	IMR1EIMK 26	IMR1EIMK 25	IMR1EIMK 24
	R/W	R/W	R/W	R/W	R	R/W	R/W	R/W
	7(7)	6(6)	5(5)	4(4)	3(3)	2(2)	1(1)	0(0)
(IMR1L)	IMR1EIMK 23	IMR1EIMK 22	IMR1EIMK 21	IMR1EIMK 20	IMR1EIMK 19	IMR1EIMK 18	IMR1EIMK 17	IMR1EIMK 16
	R/W	R/W	R/W	R/W	R/W	R/W	R/W	R/W

Bit Position	Bit Name	Function
15 to 0	IMR1EIMK31 to IMR1EIMK16	These are mask bits for EI level maskable interrupt (EIINT) channels 16 to 31 (IMR1EIMK31 to IMR1EIMK16 correspond to EIINT31 to EIINT16). 0: Enables interrupt servicing 1: Disables interrupt servicing

(3) EI Level Interrupt Mask Register 2 (IMR2)

Access Readable/writable in 1-, 8-, or 16-bit units. All of the corresponding IMR2EIMK [47:32] bits are updated simultaneously in response to writing in 8- or 16-bit units.

Address FFFF 6404_H

Initial value FFFF_H

A reset from any source will initialize the bits.

IMR2	15(7)	14(6)	13(5)	12(4)	11(3)	10(2)	9(1)	8(0)
(IMR2H)	IMR2EIMK 47	IMR2EIMK 46	IMR2EIMK 45	IMR2EIMK 44	IMR2EIMK 43	IMR2EIMK 42	IMR2EIMK 41	IMR2EIMK 40
	R/W	R/W	R/W	R/W	R/W	R/W	R/W	R/W
	7(7)	6(6)	5(5)	4(4)	3(3)	2(2)	1(1)	0(0)
(IMR2L)	IMR2EIMK 39	IMR2EIMK 38	IMR2EIMK 37	IMR2EIMK 36	IMR2EIMK 35	IMR2EIMK 34	IMR2EIMK 33	IMR2EIMK 32
	R/W	R/W	R/W	R/W	R/W	R/W	R/W	R/W

Bit Position	Bit Name	Function
15 to 0	IMR2EIMK47 to IMR2EIMK32	These are mask bits for EI level maskable interrupt (EIINT) channels 32 to 47 (IMR2EIMK47 to IMR2EIMK32 correspond to EIINT47 to EIINT32). 0: Enables interrupt servicing 1: Disables interrupt servicing

(4) EI Level Interrupt Mask Register 3 (IMR3)

Access Readable/writable in 1-, 8-, or 16-bit units. All of the corresponding IMR3EIMK [63:48] bits are updated simultaneously in response to writing in 8- or 16-bit units.

Address FFFF 6406_H

Initial value FFFF_H

This register is initialized by any reset.

IMR3	15(7)	14(6)	13(5)	12(4)	11(3)	10(2)	9(1)	8(0)
(IMR3H)	IMR3EIMK 63	IMR3EIMK 62	IMR3EIMK 61	IMR3EIMK 60	IMR3EIMK 59	IMR3EIMK 58	IMR3EIMK 57	IMR3EIMK 56
	R/W	R/W	R/W	R/W	R/W	R/W	R/W	R/W
	7(7)	6(6)	5(5)	4(4)	3(3)	2(2)	1(1)	0(0)
(IMR3L)	IMR3EIMK 55	IMR3EIMK 54	1	1	1	1	IMR3EIMK 49	IMR3EIMK 48
	R/W	R/W	R	R	R	R	R/W	R/W

Bit Position	Bit Name	Function
15 to 0	IMR3EIMK63 to IMR3EIMK48	These are mask bits for EI level maskable interrupt (EIINT) channels 48 to 63 (IMR3EIMK63 to IMR3EIMK48 correspond to EIINT63 to EIINT48). 0: Enables interrupt servicing 1: Disables interrupt servicing

(5) EI Level Interrupt Mask Register 4 (IMR4)

Access Readable/writable in 1-, 8-, or 16-bit units. All of the corresponding IMR4EIMK [79:64] bits are updated simultaneously in response to writing in 8- or 16-bit units.

Address FFFF 6408_H

Initial value FFFF_H

A reset from any source will initialize the bits.

IMR4	15(7)	14(6)	13(5)	12(4)	11(3)	10(2)	9(1)	8(0)
(IMR4H)	1	1	1	1	1	1	1	1
	R	R	R	R	R	R	R	R
	7(7)	6(6)	5(5)	4(4)	3(3)	2(2)	1(1)	0(0)
(IMR4L)	1	1	IMR4EIMK 69	IMR4EIMK 68	IMR4EIMK 67	IMR4EIMK 66	IMR4EIMK 65	IMR4EIMK 64
	R	R	R/W	R/W	R/W	R/W	R/W	R/W

Bit Position	Bit Name	Function
15 to 0	IMR4EIMK79 to IMR4EIMK64	These are mask bits for EI level maskable interrupt (EIINT) channels 64 to 79 (IMR4EIMK79 to IMR4EIMK64 correspond to EIINT79 to EIINT64). 0: Enables interrupt servicing 1: Disables interrupt servicing

(6) EI Level Interrupt Mask Register 5 (IMR5)

Access Readable/writable in 1-, 8-, or 16-bit units. All of the corresponding IMR5EIMK [95:80] bits are updated simultaneously in response to writing in 8- or 16-bit units.

Address FFFF 640A_H

Initial value FFFF_H

A reset from any source will initialize the bits.

IMR5	15(7)	14(6)	13(5)	12(4)	11(3)	10(2)	9(1)	8(0)
(IMR5H)	1	1	1	1	1	IMR5EIMK 90	IMR5EIMK 89	IMR5EIMK 88
	R	R	R	R	R	R/W	R/W	R/W
	7(7)	6(6)	5(5)	4(4)	3(3)	2(2)	1(1)	0(0)
(IMR5L)	IMR5EIMK 87	IMR5EIMK 86	1	1	1	1	1	1
	R/W	R/W	R	R	R	R	R	R

Bit Position	Bit Name	Function
15 to 0	IMR5EIMK95 to IMR5EIMK80	These are mask bits for EI level maskable interrupt (EIINT) channels 80 to 95 (IMR5EIMK95 to IMR5EIMK80 correspond to EIINT95 to EIINT80). 0: Enables interrupt servicing 1: Disables interrupt servicing

(7) EI Level Interrupt Mask Register 6 (IMR6)

Access Readable/writable in 1-, 8-, or 16-bit units. All of the corresponding IMR6EIMK [111:96] bits are updated simultaneously in response to writing in 8- or 16-bit units.

Address FFFF 640C_H

Initial value FFFF_H

A reset from any source will initialize the bits.

IMR6	15(7)	14(6)	13(5)	12(4)	11(3)	10(2)	9(1)	8(0)
(IMR6H)	IMR6EIMK 111	IMR6EIMK 110	IMR6EIMK 109	IMR6EIMK 108	1	1	1	IMR6EIMK 104
	R/W	R/W	R/W	R/W	R	R	R	R/W
	7(7)	6(6)	5(5)	4(4)	3(3)	2(2)	1(1)	0(0)
(IMR6L)	IMR6EIMK 103	IMR6EIMK 102	IMR6EIMK 101	IMR6EIMK 100	IMR6EIMK 99	1	1	1
	R/W	R/W	R/W	R/W	R/W	R	R	R

Bit Position	Bit Name	Function
15 to 0	IMR6EIMK111 to IMR6EIMK96	These are mask bits for EI level maskable interrupt (EIINT) channels 96 to 111 (IMR6EIMK111 to IMR6EIMK96 correspond to EIINT111 to EIINT96). 0: Enables interrupt servicing 1: Disables interrupt servicing

(8) EI Level Interrupt Mask Register 7 (IMR7)

Access Readable/writable in 1-, 8-, or 16-bit units. All of the corresponding IMR7EIMK [127:112] bits are updated simultaneously in response to writing in 8- or 16-bit units.

Address FFFF 640E_H

Initial value FFFF_H

A reset from any source will initialize the bits.

IMR7	15(7)	14(6)	13(5)	12(4)	11(3)	10(2)	9(1)	8(0)
(IMR7H)	IMR7EIMK 127	1	IMR7EIMK 125	IMR7EIMK 124	IMR7EIMK 123	IMR7EIMK 122	IMR7EIMK 121	IMR7EIMK 120
	R/W	R	R/W	R/W	R/W	R/W	R/W	R/W
	7(7)	6(6)	5(5)	4(4)	3(3)	2(2)	1(1)	0(0)
(IMR7L)	IMR7EIMK 119	IMR7EIMK 118	IMR7EIMK 117	1	1	1	IMR7EIMK 113	IMR7EIMK 112
	R/W	R/W	R/W	R	R	R	R/W	R/W

Bit Position	Bit Name	Function
15 to 0	IMR7EIMK127 to IMR7EIMK112	These are mask bits for EI level maskable interrupt (EIINT) channels 112 to 127 (IMR7EIMK127 to IMR7EIMK112 correspond to EIINT127 to EIINT112). 0: Enables interrupt servicing 1: Disables interrupt servicing

(9) EI Level Interrupt Mask Register 8 (IMR8)

Access Readable/writable in 1-, 8-, or 16-bit units. All of the corresponding IMR8EIMK [143:128] bits are updated simultaneously in response to writing in 8- or 16-bit units.

Address FFFF 6410_H

Initial value FFFF_H

A reset from any source will initialize the bits.

IMR8	15(7)	14(6)	13(5)	12(4)	11(3)	10(2)	9(1)	8(0)
(IMR8H)	IMR8EIMK 143	IMR8EIMK 142	IMR8EIMK 141	IMR8EIMK 140	IMR8EIMK 139	IMR8EIMK 138	IMR8EIMK 137	IMR8EIMK 136
	R/W	R/W	R/W	R/W	R/W	R/W	R/W	R/W
	7(7)	6(6)	5(5)	4(4)	3(3)	2(2)	1(1)	0(0)
(IMR8L)	IMR8EIMK 135	IMR8EIMK 134	IMR8EIMK 133	IMR8EIMK 132	IMR8EIMK 131	IMR8EIMK 130	IMR8EIMK 129	IMR8EIMK 128
	R/W	R/W	R/W	R/W	R/W	R/W	R/W	R/W

Bit Position	Bit Name	Function
15 to 0	IMR8EIMK143 to IMR8EIMK128	These are mask bits for EI level maskable interrupt (EIINT) channels 128 to 143 (IMR8EIMK143 to IMR8EIMK128 correspond to EIINT143 to EIINT128). 0: Enables interrupt servicing 1: Disables interrupt servicing

(10) EI Level Interrupt Mask Register 9 (IMR9)

Access Readable/writable in 1-, 8-, or 16-bit units. All of the corresponding IMR9EIMK [159:144] bits are updated simultaneously in response to writing in 8- or 16-bit units.

Address FFFF 6412_H

Initial value FFFF_H

A reset from any source will initialize the bits.

IMR9	15(7)	14(6)	13(5)	12(4)	11(3)	10(2)	9(1)	8(0)
(IMR9H)	1	1	1	1	1	1	1	1
	R	R	R	R	R	R	R	R
	7(7)	6(6)	5(5)	4(4)	3(3)	2(2)	1(1)	0(0)
(IMR9L)	1	1	1	1	1	1	IMR9EIMK 145	IMR9EIMK 144
	R	R	R	R	R	R	R/W	R/W

Bit Position	Bit Name	Function
15 to 0	IMR9EIMK159 to IMR9EIMK144	These are mask bits for EI level maskable interrupt (EIINT) channels 144 to 159 (IMR9EIMK159 to IMR9EIMK144 correspond to EIINT159 to EIINT144). 0: Enables interrupt servicing 1: Disables interrupt servicing

(11) EI Level Interrupt Mask Register 10 (IMR10)

Access Readable/writable in 1-, 8-, or 16-bit units. All of the corresponding IMR10EIMK[175:160] bits are updated simultaneously in response to writing in 8- or 16-bit units.

Address FFFF 6414_H

Initial value FFFF_H

A reset from any source will initialize the bits.

IMR10	15(7)	14(6)	13(5)	12(4)	11(3)	10(2)	9(1)	8(0)
(IMR10H)	IMR10EIMK 175	IMR10EIMK 174	IMR10EIMK 173	1	1	1	1	1
	R/W	R/W	R/W	R	R	R	R	R
	7(7)	6(6)	5(5)	4(4)	3(3)	2(2)	1(1)	0(0)
(IMR10L)	IMR10EIMK 167	IMR10EIMK 166	IMR10EIMK 165	IMR10EIMK 164	IMR10EIMK 163	1	1	1
	R/W	R/W	R/W	R/W	R/W	R	R	R

Bit Position	Bit Name	Function
15 to 0	IMR10EIMK 175 to IMR10EIMK 160	These are mask bits for EI level maskable interrupt (EIINT) channels 160 to 175 (IMR10EIMK175 to IMR10EIMK160 correspond to EIINT175 to EIINT160). 0: Enables interrupt servicing 1: Disables interrupt servicing

(12) EI Level Interrupt Mask Register 11 (IMR11)

Access Readable/writable in 1-, 8-, or 16-bit units. All of the corresponding IMR11EIMK[191:176] bits are updated simultaneously in response to writing in 8- or 16-bit units.

Address FFFF 6416_H

Initial value FFFF_H

A reset from any source will initialize the bits.

IMR11	15(7)	14(6)	13(5)	12(4)	11(3)	10(2)	9(1)	8(0)
(IMR11H)	1	1	1	1	1	1	1	1
	R	R	R	R	R	R	R	R
	7(7)	6(6)	5(5)	4(4)	3(3)	2(2)	1(1)	0(0)
(IMR11L)	1	IMR11EIMK 182	IMR11EIMK 181	1	1	1	1	1
	R	R/W	R/W	R	R	R	R	R

Bit Position	Bit Name	Function
15 to 0	IMR11EIMK191 to IMR11EIMK176	These are mask bits for EI level maskable interrupt (EIINT) channels 176 to 191 (IMR11EIMK191 to IMR11EIMK176 correspond to EIINT191 to EIINT176). 0: Enables interrupt servicing 1: Disables interrupt servicing

(13) EI Level Interrupt Mask Register 12 (IMR12)

Access Readable/writable in 1-, 8-, or 16-bit units. All of the corresponding IMR12EIMK[207:192] bits are updated simultaneously in response to writing in 8- or 16-bit units.

Address FFFF 6418_H

Initial value FFFF_H

A reset from any source will initialize the bits.

IMR12	15(7)	14(6)	13(5)	12(4)	11(3)	10(2)	9(1)	8(0)
(IMR12H)	1	1	1	1	1	IMR12EIMK 202	IMR12EIMK 201	IMR12EIMK 200
	R	R	R	R	R	R/W	R/W	R/W
	7(7)	6(6)	5(5)	4(4)	3(3)	2(2)	1(1)	0(0)
(IMR12L)	IMR12EIMK 199	IMR12EIMK 198	IMR12EIMK 197	IMR12EIMK 196	IMR12EIMK 195	IMR12EIMK 194	IMR12EIMK 193	1
	R/W	R/W	R/W	R/W	R/W	R/W	R/W	R

Bit Position	Bit Name	Function
15 to 0	IMR12EIMK202 to IMR12EIMK192	These are mask bits for EI level maskable interrupt (EIINT) channels 192 to 207 (IMR12EIMK202 to IMR12EIMK192 correspond to EIINT202 to EIINT192). 0: Enables interrupt servicing 1: Disables interrupt servicing

(14) EI Level Interrupt Mask Register 13 (IMR13)

Access Readable/writable in 1-, 8-, or 16-bit units. All of the corresponding IMR12EIMK[223:208] bits are updated simultaneously in response to writing in 8- or 16-bit units.

Address FFFF 641A_H

Initial value FFFF_H

A reset from any source will initialize the bits.

IMR12	15(7)	14(6)	13(5)	12(4)	11(3)	10(2)	9(1)	8(0)
(IMR13H)	1	1	1	IMR13EIMK 220	1	1	1	1
	R	R	R	R/W	R	R	R	R
	7(7)	6(6)	5(5)	4(4)	3(3)	2(2)	1(1)	0(0)
(IMR13L)	1	1	1	1	1	1	1	1
	R	R	R	R	R	R	R	R

Bit Position	Bit Name	Function
15 to 0	IMR12EIMK223 to IMR12EIMK208	These are mask bits for EI level maskable interrupt (EIINT) channels 223 to 208 (IMR13EIMK223 to IMR13EIMK208 correspond to EIINT223 to EIINT208). 0: Enables interrupt servicing 1: Disables interrupt servicing

4.3.3 ISPR – In-Service Priority Register

This register holds the interrupt priority of EI level maskable interrupt (EIINT) that is being processed by the CPU. When this register receives a response to interrupt request reception from the CPU core, the bit corresponding to the interrupt priority of that interrupt request is set. When this register receives a notification that interrupt servicing is complete, the highest priority bit from among the set bits is automatically cleared. The bits are not cleared on recovery from an FE level interrupt. When multiple EI level maskable interrupts (EIINT) are generated, this register sets the bits in sequence corresponding to the received priority levels and thus holds a history of the interrupt priority levels.

Access This register can be read* in 8- or 16-bit units.

Either the eight higher-order bits [15:8] or lower-order bits [7:0] may be accessed by reading in 8-bit units.

Address FFFF 6440_H

Initial value 0000_H

A reset from any source will initialize the bits.

ISPR	15(7)	14(6)	13(5)	12(4)	11(3)	10(2)	9(1)	8(0)
(ISPRH)	ISPR15	ISPR14	ISPR13	ISPR12	ISPR11	ISPR10	ISPR9	ISPR8
	R*	R*	R*	R*	R*	R*	R*	R*
	7(7)	6(6)	5(5)	4(4)	3(3)	2(2)	1(1)	0(0)
(ISPRL)	ISPR7	ISPR6	ISPR5	ISPR4	ISPR3	ISPR2	ISPR1	ISPR0
	R*	R*	R*	R*	R*	R*	R*	R*

Bit Position	Bit Name	Function
15 to 0	ISPR15 to ISPR0	These bits indicate the priority of the interrupt being acknowledged. 0: Interrupt request of the priority corresponding to the bit position is not acknowledged. 1: Interrupt request of the priority corresponding to the bit position is being processed by the CPU core.

Note All of the bits in ISPR can be cleared by simultaneously writing 1 to all bits of register ISPC and then simultaneously writing 0 to all bits of ISPR (i.e. by using 16-bit operations). Clearing and setting individual bits as required by software writing to this register is not possible. Once the bits are cleared, the original values are not retrievable. For details on ISPC register, refer to Section 4.3.5, ISPC – In-Service Priority Clear Register.

4.3.4 PMR – Priority Mask Register

This register specifies an interrupt priority by which an interrupt request flag of EI level maskable interrupt (EIINT) is to be masked. It disables all at once the interrupt requests from the EIINT channel for which the interrupt priority specified by this register is set.

The position of each bit of this register corresponds to an interrupt priority. For example, if 1 is set to bit 0, channel of interrupt priority 0 can be masked.

Access Readable/writable in 1-, 8-, or 16-bit units.

Either the eight higher-order bits [15:8] or lower-order bits [7:0] may be accessed by reading in 8-bit units.

Address FFFF 6448_H

Initial value 0000_H

A reset from any source will initialize the bits.

PMR	15(7)	14(6)	13(5)	12(4)	11(3)	10(2)	9(1)	8(0)
(PMRH)	PMR15	PMR14	PMR13	PMR12	PMR11	PMR10	PMR9	PMR8
	R/W	R/W	R/W	R/W	R/W	R/W	R/W	R/W
	7(7)	6(6)	5(5)	4(4)	3(3)	2(2)	1(1)	0(0)
(PMRL)	PMR7	PMR6	PMR5	PMR4	PMR3	PMR2	PMR1	PMR0
	R/W	R/W	R/W	R/W	R/W	R/W	R/W	R/W

Bit Position	Bit Name	Function
15 to 0	PMR15 to PMR0	These bits specify an interrupt priority by which an interrupt request flag is masked: 0 : Enables interrupt servicing of the priority corresponding to a specified bit position (initial value). 1 : Disables interrupt servicing of the priority corresponding to a specified bit position.

4.3.5 ISPC – In-Service Priority Clear Register

This register is for the clearing of settings for interrupt priority and for the control of operations.

Follow the procedure below to clear ISPR.

1. Write $FFFF_H$ to ISPC.ISPC[15:0] (as a 16-bit unit).
2. Write 0000_H to ISPR.ISPR[15:0] (as a 16-bit unit).

At the same time, the bits indicating processing of an FE level NMI, FE level-maskable interrupt (FEINT), and EI level-maskable interrupt (EIINT) are cleared in ICSR. This clears all interrupt processing mode registers within the interrupt controller that control the processing in progress of interrupt requests by the CPU core. Once the bits have been cleared (to 0), their original values are not retrievable by software.

When the ISPR is cleared by writing 0 to it, the value in the ISPC is also automatically cleared to 0. When register ISPC is read, the value 1 is read from all bits after 1 has been written to all bits, and the value 0 is read from all bits after a reset or clearing of the ISPR. Writing other than writing 1 to all bits or 0 to all bits leaves the register's value unchanged. Furthermore, although writing 0 to all bits while all bits currently have the value 1 clears all bits of register ISPC to 0 but leaves the value in ISPR unchanged.

Access Readable/writable in 16-bit units only.

Address $FFFF\ 6450_H$

Initial value 0000_H

A reset from any source will initialize the bits.

ISPC	15	14	13	12	11	10	9	8
	ISPC15	ISPC14	ISPC13	ISPC12	ISPC11	ISPC10	ISPC9	ISPC8
	R/W	R/W	R/W	R/W	R/W	R/W	R/W	R/W
	7	6	5	4	3	2	1	0
	ISPC7	ISPC6	ISPC5	ISPC4	ISPC3	ISPC2	ISPC1	ISPC0
	R/W	R/W	R/W	R/W	R/W	R/W	R/W	R/W

Bit Position	Bit Name	Function
15 to 0	ISPC15 to ISPC0	Controls clearing of bits of the in-service priority register (ISPR.ISPR[15:0]). When the register is read, either all bits are read as 1 or all bits are read as 0. When 1 is read from all of the bits, writing 0 to all bits of the ISPR will clear the ISPR.

4.3.6 SCR – Selected Channel Hold Register

This register holds the channel number of the EI level maskable interrupt (EIINT). The value of this register is updated when an interrupt vector is reported to the CPU core.

Access This register is read-only and is read in 8- or 16-bit units.

Either the eight higher-order bits [15:8] or lower-order bits [7:0] may be accessed by reading in 8-bit units.

Address FFFF 6458_H

Initial value 0000_H

A reset from any source will initialize the bits.

SCR	15	14	13	12	11	10	9	8
	0	0	0	0	0	0	0	0
	R	R	R	R	R	R	R	R
(SCRL)	7	6	5	4	3	2	1	0
	SCR7	SCR6	SCR5	SCR4	SCR3	SCR2	SCR1	SCR0
	R	R	R	R	R	R	R	R

Bit Position	Bit Name	Function
7 to 0	SCR7 to SCR0	<p>Holds the channel number of the maskable interrupt that has been acknowledged by the CPU.</p> <p>Caution 1. It is overwritten when multiple interrupts of EI level maskable interrupt (EIINT) are acknowledged.</p> <p>Caution 2. These bits are not updated when an FE level interrupt is acknowledged.</p>

4.3.7 ICSR – Interrupt Controller Status Register

This register indicates the operation status of the interrupt controller.

Access This register is read-only and is read in 1-, 8-, or 16-bit units.

Either the eight higher-order bits [15:8] or lower-order bits [7:0] may be accessed by reading in 8-bit units.

Address FFFF 645A_H

Initial value 0000_H

A reset from any source will initialize the bits.

ICSR	15	14	13	12	11	10	9	8
(ICSRH)	0	0	0	0	0	0	0	ICSRPMF
	R	R	R	R	R	R	R	R
	7	6	5	4	3	2	1	0
(IC SRL)	0	ICSRFNR	ICSRFIR	ICSREIR	0	ICSRFNE	ICSRFIE	ICSREIE
	R	R	R	R	R	R	R	R

Bit Position	Bit Name	Function
8	ICSRPMF	Indicates 1 if the request flag of a channel of EI level maskable interrupt (EIINT) that has the interrupt priority prohibited by the setting of PMR from being serviced is set.
6	ICSRFNR	Indicates 1 if an FE level non-maskable interrupt (FENMI) has been issued to the CPU.
5	ICSRFIR	Indicates 1 if an FE level maskable interrupt (FEINT) has been issued to the CPU.
4	ICSREIR	Indicates 1 if an EI level maskable interrupt (EIINT) has been issued to the CPU.
2	ICSRFNE	Indicates 1 if an CPU is processing the FE level non-maskable interrupt (FENMI).
1	ICSRFIE	Indicates 1 if an CPU is processing the FE level maskable interrupt (FEINT).
0	ICSREIE	Indicates 1 if an CPU is processing the EI level maskable interrupt (EIINT).

4.3.8 FNC – FE Level NMI Status Register

This register is a flag register that indicates the state of control for FE level non-maskable interrupt (FENMI).

Access This register is read-only and is read in 1-, 8-, or 16-bit units.

Either the eight higher-order bits [15:8] or lower-order bits [7:0] may be accessed by reading in 8-bit units.

Address FFFF 645C_H

Initial value 0000_H

A reset from any source will initialize the bits.

FNC	15	14	13	12	11	10	9	8
(FNCH)	0	0	0	FNRF	0	0	0	0
	R	R	R	R	R	R	R	R
	7	6	5	4	3	2	1	0
	0	0	0	0	0	0	0	0
	R	R	R	R	R	R	R	R

Bit Position	Bit Name	Function
12	FNRF	Interrupt request flag 0: No interrupt request (initial value) 1: Interrupt request occurred

4.3.9 FIC – FE Level INT Status Register

This register is a flag register that indicates the state of control for FE level maskable interrupt (FEINT).

Access This register is read-only and is read in 1-, 8-, or 16-bit units.

Either the eight higher-order bits [15:8] or lower-order bits [7:0] may be accessed by reading in 8-bit units.

Address FFFF 645E_H

Initial value 0000_H

A reset from any source will initialize the bits.

FIC	15	14	13	12	11	10	9	8
(FICH)	0	0	0	FIRF	0	0	0	0
	R	R	R	R	R	R	R	R
	7	6	5	4	3	2	1	0
	0	0	0	0	0	0	0	0
	R	R	R	R	R	R	R	R

Bit Position	Bit Name	Function
12	FIRF	Interrupt request flag 0: No interrupt request (initial value) 1: Interrupt request occurred

4.3.10 INTCFGB – FE level Interrupt Switch Register

This register specifies the destination for output from an interrupt source that is switchable between FE-level and EI-level operation.

Once a value has been written to this register, the value is locked into the register until a reset.

Access This register is readable and writable in 1- and 8-bit units. Do not write 1 to any bit for which no function is indicated.

Bits 6 to 0 are always returned as 0 when this register is read.

Address FF83 A000_H

Initial value 00_H

A reset from any source will initialize the bits.

	7	6	5	4	3	2	1	0
INTCFGB	INTCFGSL0	0	0	0	0	0	0	0
	R/W	R	R	R	R	R	R	R

Bit Position	Bit Name	Function
7	INTCFGSL0	0: The INTCME, INTWDTA0NMI, INTCLMA1 and INTCLMA2 interrupts generate an FENMI. The INTISG interrupt generates a FEINT. 1: The INTCME interrupt is output as the EIINT0 interrupt, the INTISG interrupt is output as the EIINT1 interrupt, the INTWDTA0NMI interrupt is output as the EIINT2 interrupt, the INTCLMA1 interrupt is output as the EIINT5 interrupt, and the INTCLMA2 interrupt is output as the EIINT6 interrupt.

Procedure for settings

The procedure for switching an FE level interrupt to an EI level interrupt is given below.

1. Release from reset.
2. Disable output of interrupt signals from the safety guardian (INTISG signals); output is disabled with the initial value.
3. Select EI-level operation by writing to this register (INTCFGB).
4. Enable operation of WDTA0, CLMA1 and CLMA2, and output of interrupt signals from the safety guardian.

Caution When changing the setting of this register, only do so when the state is such that interrupts from none of the following sources will be generated (i.e. before their operation is enabled).

- INTISG
- INTWDTA0NMI
- INTCLMA1, INTCLMA2

4.3.11 INTSTR0B – Error Interrupt Source Storage Register

This register identifies whether an interrupt request is generated or not from an interrupt source that is switchable between FE-level and EI-level operation.

An individual bit is set by either the generation of an interrupt from the corresponding source or writing to the corresponding bit in the INTSTS0B register.

An individual bit is cleared by either writing 1 to the corresponding bit in the error interrupt source flag clearing trigger register (INTSTCOB) or a reset.

Access This register is read-only and may be read in 1- or 8-bit units.

Address FF83 A004_H

Initial value 00_H

A reset from any source will initialize the bits.

	7	6	5	4	3	2	1	0
INTSTR0B	0	0	INTISTF5	INTISTF4	0	INTISTF2	INTISTF1	INTISTF0
	R	R	R	R	R	R	R	R

Bit Position	Bit Name	Function
5	INTISTF5	0: The INTCLMA2 interrupt is not requested. 1: The INTCLMA2 interrupt is requested.
4	INTISTF4	0: The INTCLMA1 interrupt is not requested. 1: The INTCLMA1 interrupt is requested.
2	INTISTF2	0: The INTWDTAONMI interrupt is not requested. 1: The INTWDTAONMI interrupt is requested.
1	INTISTF1	0: The INTISG interrupt is not requested. 1: The INTISG interrupt is requested. The INTISG interrupt signal is masked.
0	INTISTF0	0: The INTCME interrupt is not requested. 1: The INTCME interrupt is requested. The INTCME interrupt signal is masked.

- Caution 1. When the INTSTR0B.INTISTF1 or 0 bit is 1, the given interrupt source is masked to avoid the generation of multiple interrupts. With INTCLMA2, INTCLMA1 and INTWDTAONMI, further interrupts will not be generated once one interrupt has been generated and until a reset is input. Clear the bit if the generation of multiple interrupts or a new interrupt is required.
- Caution 2. When a CPU comparison error occurs, an SGA status register (specifically the SGAmESSTR0.SGAmSSE005 bit) must be read to determine whether the error has occurred because in some cases the error indicator will not be set in register INTSTR0B (interrupt error source storage register).

4.3.12 INTSTC0B – Interrupt Request Flag Clearing Register

This register is used to clear error interrupt source flags.

Writing 1 to a bit corresponding to an interrupt request flag that you wish to clear causes clearing of the corresponding flag in the interrupt request flag storage register (INTSTR0B) and the value of the bit in this register reverts to 0.

Access This register is write-only with writing in 1- or 8-bit units. Do not write 1 to any bit for which no function is indicated.

This register always returns 0 when read.

Address FF83 A008_H

Initial value 00_H

A reset from any source will initialize the bits.

	7	6	5	4	3	2	1	0
INTSTC0B	0	0	INTISTC5	INTISTC4	0	INTISTC2	INTISTC1	INTISTC0
	W	W	W	W	W	W	W	W

Bit Position	Bit Name	Function
5	INTISTC5	0: No processing. This bit is always read as 0. 1: Clears the INTISTF5 flag.
4	INTISTC4	0: No processing. This bit is always read as 0. 1: Clears the INTISTF4 flag.
2	INTISTC2	0: No processing. This bit is always read as 0. 1: Clears the INTISTF2 flag.
1	INTISTC1	0: No processing. This bit is always read as 0. 1: Clears the INTISTF1 flag.
0	INTISTC0	0: No processing. This bit is always read as 0. 1: Clears the INTISTF0 flag.

4.3.13 INTSTS0B – Interrupt Request Flag Setting Register

This register sets an interrupt error source flag.

Writing 1 to a bit corresponding to an interrupt request flag that you wish to set causes setting of the corresponding flag in the interrupt error source storage register to 1 and the value of the bit in this register reverts to 0.

An interrupt will not be generated when a bit in this register is set to 1.

Access This register is write-only with writing in 1- or 8-bit units. Do not write 1 to any bit for which no function is indicated. This register always returns 0 when read.

Address FF83 A00C_H

Initial value 00_H

A reset from any source will initialize the bits.

	7	6	5	4	3	2	1	0
INTSTS0B	0	0	INTISTS5	INTISTS4	0	INTISTS2	INTISTS1	INTISTS0
	W	W	W	W	W	W	W	W

Bit Position	Bit Name	Function
5	INTISTS5	0: No processing. This bit is always read as 0. 1: Sets INTISTF5 flag.
4	INTISTS4	0: No processing. This bit is always read as 0. 1: Sets INTISTF4 flag.
2	INTISTS2	0: No processing. This bit is always read as 0. 1: Sets INTISTF2 flag.
1	INTISTS1	0: No processing. This bit is always read as 0. 1: Sets INTISTF1 flag.
0	INTISTS0	0: No processing. This bit is always read as 0. 1: Sets INTISTF0 flag.

4.4 Interrupt Acknowledgment and Restoring

This section describes the operation during interrupt acknowledgment and restoring from interrupt servicing.

4.4.1 FE Level Non-Maskable Interrupt Caused by FENMI Interrupt Request

When an FENMI interrupt is requested, an FE level non-maskable interrupt is generated in CPU. This FE level non-maskable interrupt is used when a fatal system error occurs.

Caution Upon acknowledgment of the FENMI interrupt, generation of the next FENMI, FEINT, or EIINT interrupt is pended until the FERET instruction is executed (interrupt request is acknowledged and held.) FENMI can be acknowledged even when the NP bit is set to 1. Therefore, if the FENMI interrupt occurs during the processing of an FEINT exception, PPI exception, or other FE level exceptions, the save address is lost and cannot be restored. After a FENMI interrupt is requested and the required processing has been completed, execute a system reset.

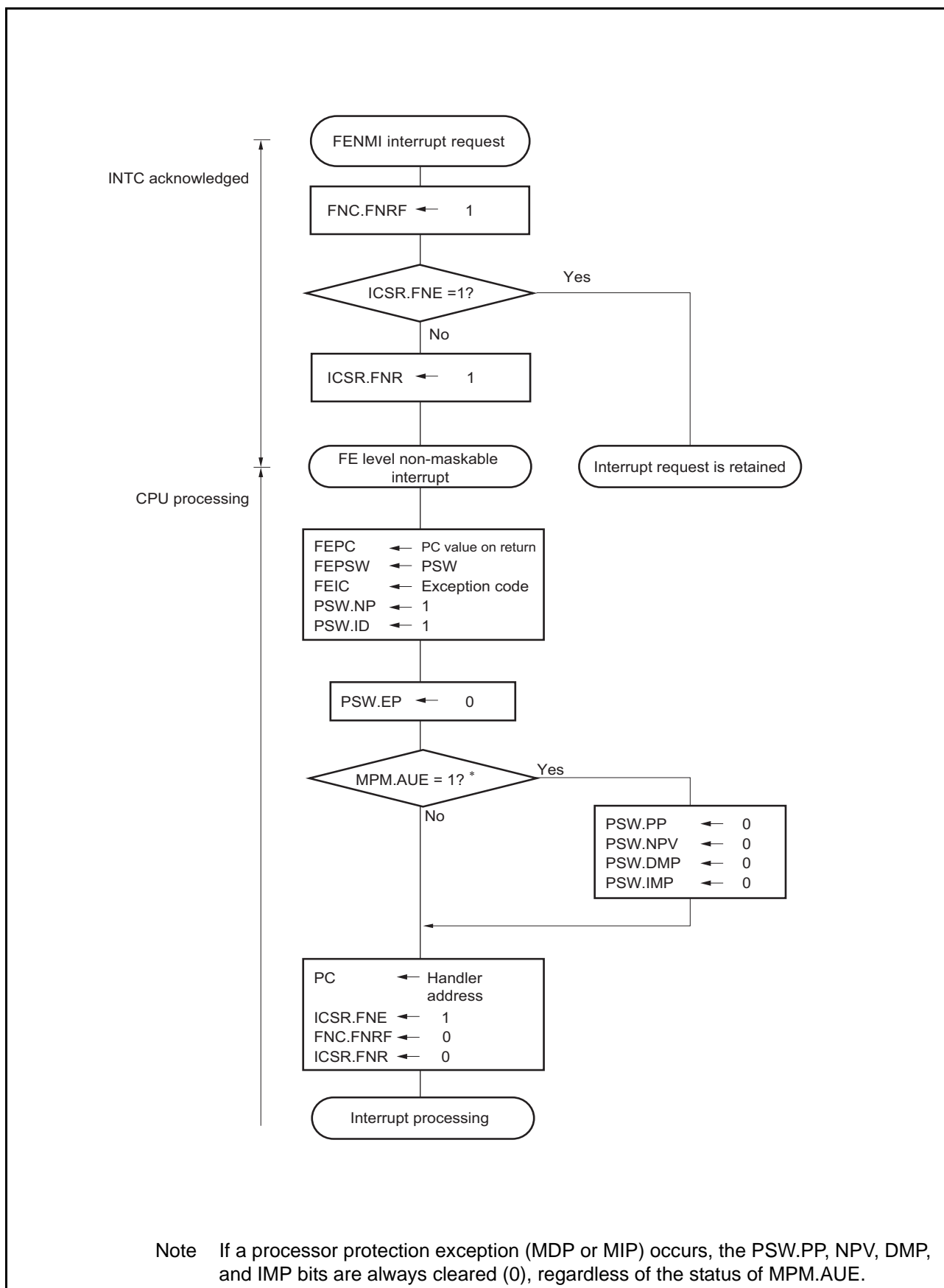

Figure 4-1 Processing upon Occurrence of FENMI Interrupt Request

4.4.2 Restore from FE Level Non-Maskable Interrupt (FENMI)

An FE level non-maskable interrupt (FENMI) cannot be restored since it is an interrupt used in cases such as when a fatal system error occurs. Execute a system reset after exception processing.

4.4.3 FE Level Maskable Interrupt Caused by FEINT Interrupt Request

When an FEINT interrupt is requested by the FEINT pin, an FE level maskable interrupt is generated. This interrupt is a recoverable FE level interrupt.

Upon acknowledgment of the FEINT interrupt, generation of the next FEINT or EIINT interrupt is pended until the FERET instruction is executed. Interrupt request is acknowledged and held.

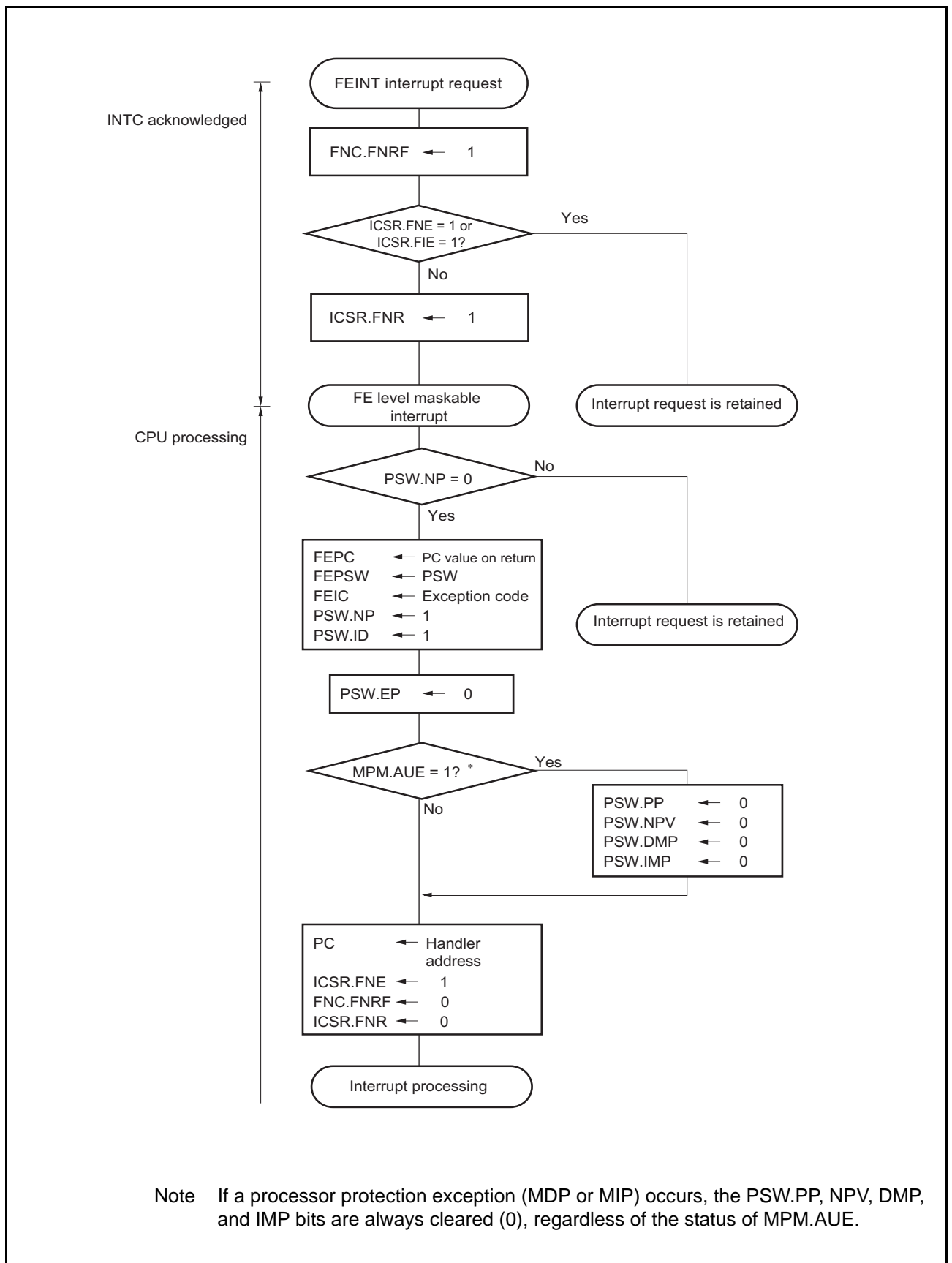

Figure 4-2 Processing upon Occurrence of FEINT Interrupt Request

4.4.4 Restore from FE Level Maskable Interrupt (FEINT) Servicing

Restore from FE level maskable interrupt (FEINT) servicing is performed using the FERET instructions. Execution of the FERET instruction while the PSW.EP bit status is cleared (0) causes restore processing from the FE level maskable interrupt (FEINT). Completely restoring from interrupt servicing when the PSW.EP bit is "1" is not possible (clearing of the ICSR, ISPR, and other registers is not performed). For return from FE level maskable interrupts (FEINT), execute the FERET instruction with the PSW.EP bit always cleared (0).

Caution Although this CPU core incorporates an RETI instruction, this is only provided for backward compatibility with the V850E1 and V850E2 architectures and its use is, in principle, prohibited. Replace all RETI instructions other than existing programs that cannot be modified with EIRET or FERET instructions.

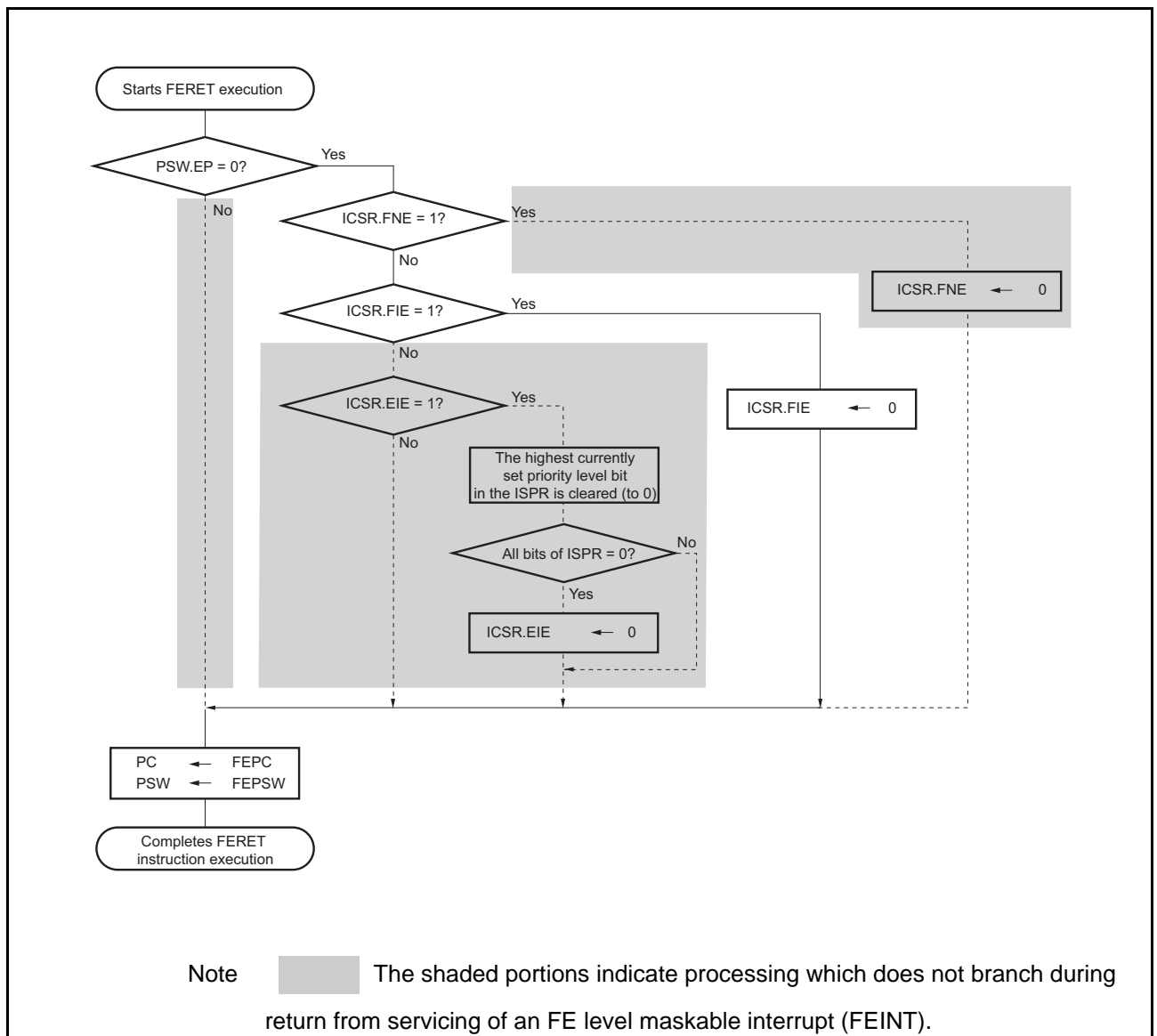

Figure 4-3 Restore from FE Level Maskable Interrupt (FEINT) Servicing

4.4.5 EI Level Maskable Interrupt Caused by EIINT Interrupt Request

An EI level-maskable interrupt leads to an EIINT interrupt request for the CPU: the transition to the interrupt handler is in accord with the setting of the IMR register in the interrupt controller (INTC). This interrupt is a recoverable EI level interrupt.

In the case of an EIINT interrupt, the channel number where the interrupt input occurred is set to the SCR register. As a result, the channel number can be easily known when wishing to share the same interrupt vectors among several channels.

Caution Upon acknowledgment of the EI level interrupt, the priority level of the currently acknowledged interrupt is registered to the ISPR register (in-service priority register). Then, until execution of the EIRET instruction, interrupt with a priority level lower than that of this ISPR register are not generated. Interrupt request is acknowledged and held.

Registration of the priority level of the currently acknowledged interrupt and deletion of the priority level of the interrupt during EIRET to/from the ISPR register are automatically performed by the hardware. Write to the ISPR register cannot be performed by software. Write operations are ignored.

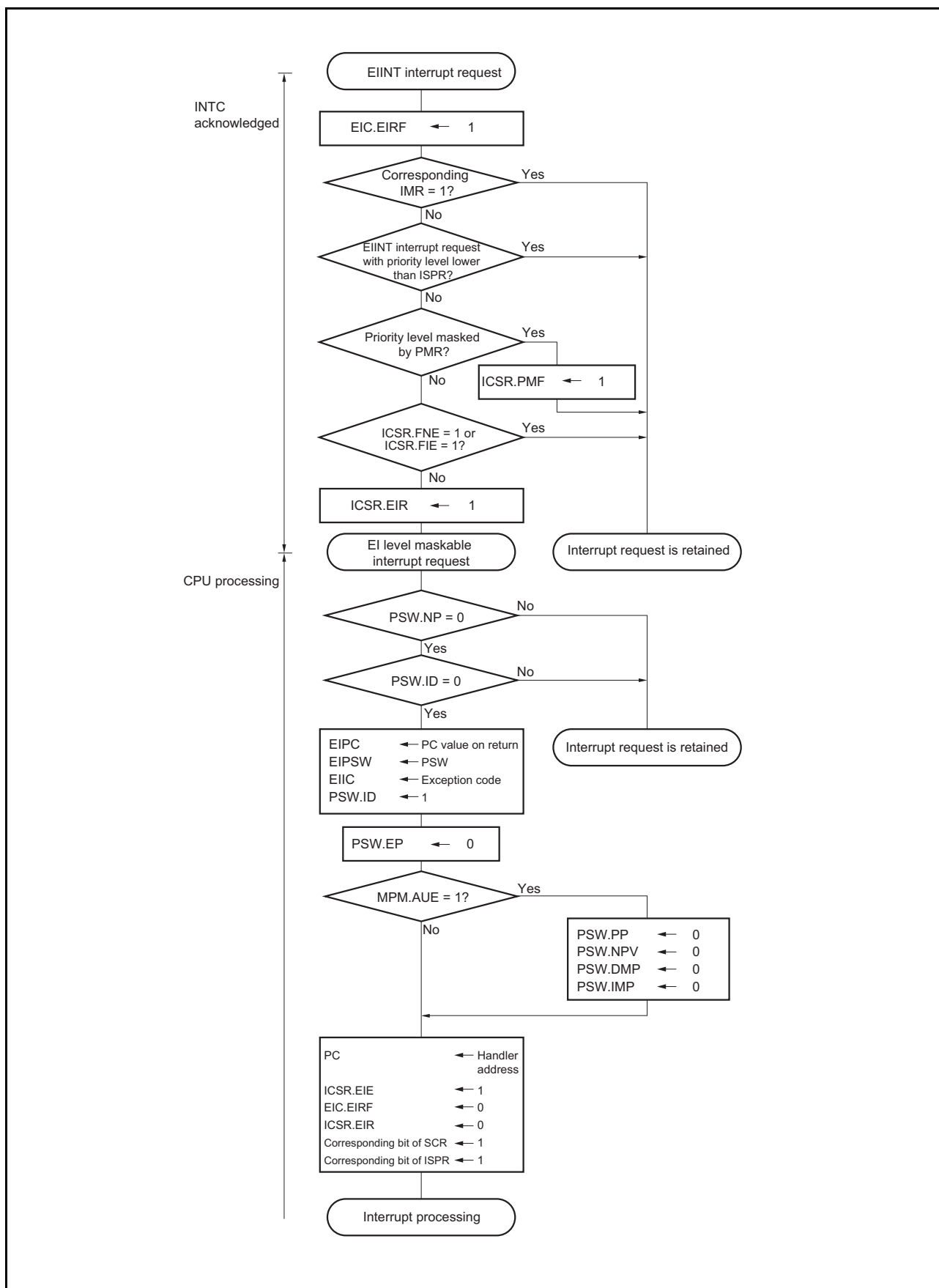

Figure 4-4 Processing upon Occurrence of EIINT Interrupt Request

4.4.6 Restore from EI Level Maskable Interrupt (EIINT)

Restore from EI level maskable interrupt (EIINT) is performed using the EIRET instruction. Execution of the EIRET instruction while the PSW.EP bit status is cleared (0) causes restore processing from the interrupt. Completely restoring from interrupt servicing when the PSW.EP bit is "1" is not possible (clearing of the ICSR, ISPR, and other registers is not performed). For return from EI level maskable interrupt, execute the EIRET instruction with the PSW.EP bit always cleared (0).

Caution Although this CPU core incorporates an RETI instruction, this is only provided for backward compatibility with the V850E1 and V850E2 architectures and its use is, in principle, prohibited. Replace all RETI instructions other than existing programs that cannot be modified with EIRET or FERET instructions.

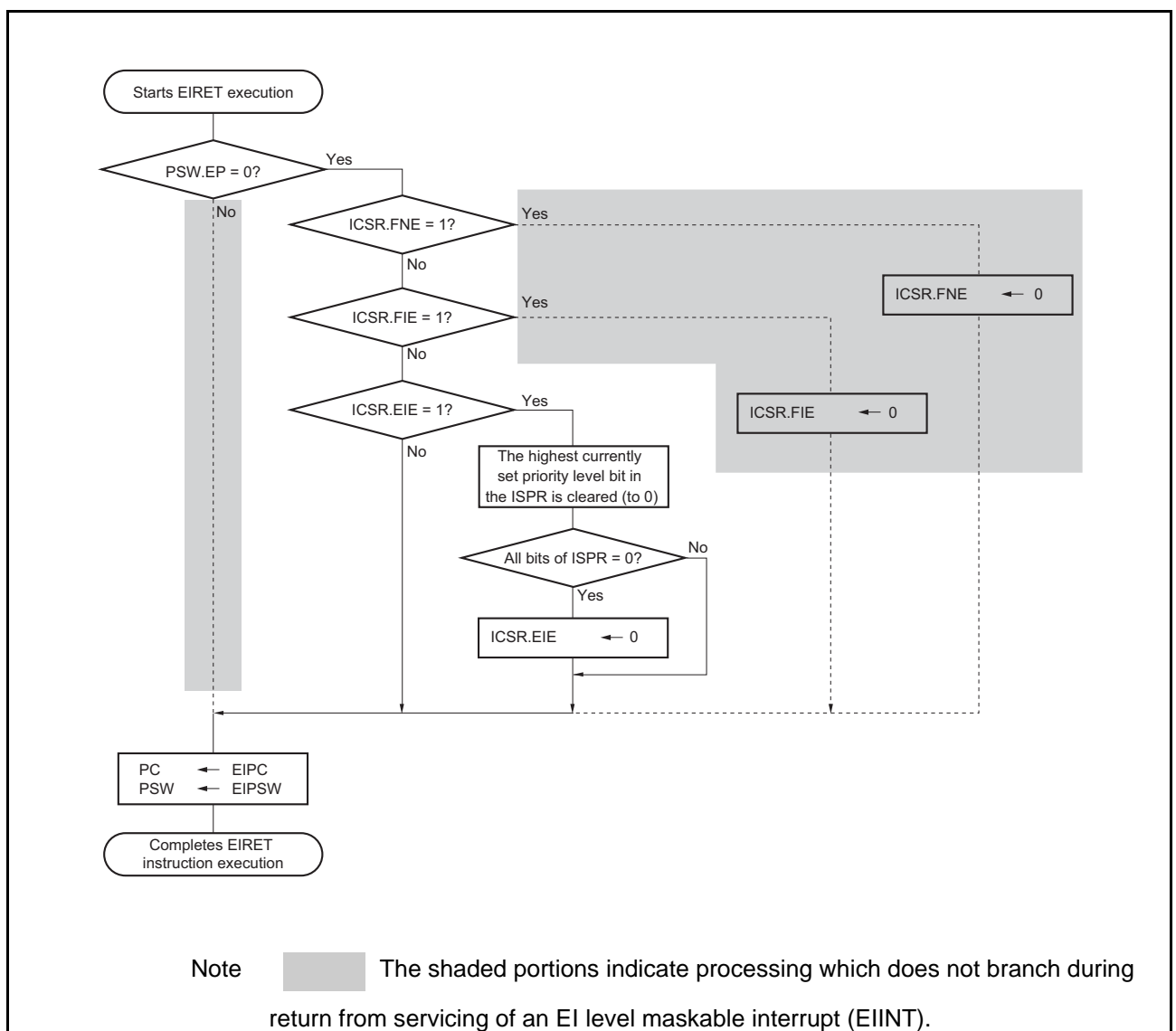

Figure 4-5 Restore from EI Level Maskable Interrupt (EIINT)

4.5 Interrupt Operation

4.5.1 Mask Function of EI Level Maskable Interrupt (EIINT)

Interrupt masking can be specified for each respective interrupt channel of EIINT. Interrupt masking is performed by doing the following register settings.

ICxx.MKxx	Operation
1	Masks interrupt.
0	Enables interrupt.

An ICxx.MKxx bit works in conjunction with the corresponding IMRmEIMKn (n = 223) bit, so values can be read from and written to the IMRm (m = 0 to 13) registers.

1. Writing 1 to an IMRmEIMKn bit prohibits interrupts on the corresponding channel.
2. When an ICxx.MKxx bit is read, it is read as 1.

Caution For ICxx.MKxx and IMRm.IMRmEIMKn bits, processing subsequent to retention of the interrupt is masked. Acceptance and holding of interrupt requests still proceeds if the ICxx.MKxx and IMRm.IMRmEIMKn bits are set to 1. Furthermore, when an interrupt is blocked by setting of the ICxx.MKxx or IMRm.IMRmEIMKn bit, an interrupt will not be generated even if software requests an interrupt. Moreover, when the value 0 is restored to an ICxx.MKxx and IMRm.IMRmEIMKn bit that is blocking an interrupt request while the request is held pending, the interrupt will be generated at that time. To delete a pending interrupt request that is currently held pending, clear the corresponding ICxx.RFxx bit.

4.5.2 Interrupt Priority Level Judgment

When an FE level non-maskable interrupt (FENMI), FE level maskable interrupt (FEINT), or EI level maskable interrupt (EIINT) is input, the priority levels of other exceptions are taken into account in determining which is to proceed, and the request becomes that for the exception with the highest priority (including the interrupt).

Exceptions requested at the same time (including interrupts) are processed in a pre-allocated priority order (the default priority order). The priority orders of FENMI, FEINT, and EIINT interrupts are as follows.

FENMI > FEINT > EIINT

(For other exceptions, see Table 4-2, List of Interrupt Sources, and V850E2M Architecture Manual (R01US0001E).)

The priority of EIINT interrupts can be set for each interrupt source. The interrupt priority is set in the range from 0 to 15 by the ICxx.P3xx to ICxx.P0xx bits. 0 is for the highest priority level and 15 is for the lowest. If two or more EIINT interrupts have the same priority level, the interrupt with the lowest channel number takes the priority.

Table 4-4 Example of EIINT Interrupt Priority Level Settings and Priority Levels

EIINT	P3xx to P0xx Setting	Priority Level During Operation
EIINT0	3	10
EIINT1	4	11
EIINT2	0	1
EIINT3	0	2
EIINT4	1	3
EIINT5	2	6
EIINT6	2	7
EIINT7	1	4
EIINT8	1	5
EIINT9	2	8
EIINT10	2	9

During interrupt servicing, the interrupt controller also processes multiple interrupts acknowledging other interrupts. When multiple EIINT interrupts are requested at the same time, the interrupt to be acknowledged is determined with the following procedure.

(1) Comparison with the Priority Level as the Interrupt Currently Being Serviced

Interrupts with the same or lower priority level as the interrupt currently being serviced are held.

The priority level of the interrupt currently being serviced is held in the ISPR register.

Interrupts with a higher priority level than the interrupt currently being serviced go on to the next priority judgment stage.

(2) Masking through Priority Mask Register (PMR)

Only interrupts enabled by the PMR register go on to the next priority judgment stage.

(3) Of the Requested Interrupt Sources, that with the Highest Priority Level is Selected

In the case of simultaneous interrupt requests at the highest priority level from multiple sources, that with the lowest interrupt channel number is selected.

(4) Interrupt Hold by CPU

Interrupt acknowledgment is pended according to the state of the NP and ID bits of the PSW register. At this time, priority judgment among EIINT interrupts, and priority judgment among EIINT interrupts, FEINT interrupts, and FENMI interrupts is performed even while interrupt acknowledgment is pended, and the interrupt with the highest priority is selected upon realization of the acknowledgment condition.

Example When a priority level 5 EIINT interrupt has already been requested and interrupt generation is pended because the value of the PSW.ID bit is "1", a subsequent priority level 3 EIINT interrupt is requested. Then, if the PSW.ID bit is cleared (0), the priority level 3 EIINT interrupt is generated.

Multiple interrupt servicing in which an interrupt is acknowledged while another interrupt is being serviced is shown in Figure 4-6.

When an interrupt request signal is acknowledged, the PSW.ID flag is automatically set to 1. Therefore, when multiple interrupts are to be used, clear the ID flag to 0 beforehand (for example, by placing the EI instruction in the interrupt service program) to set the interrupt enable mode.

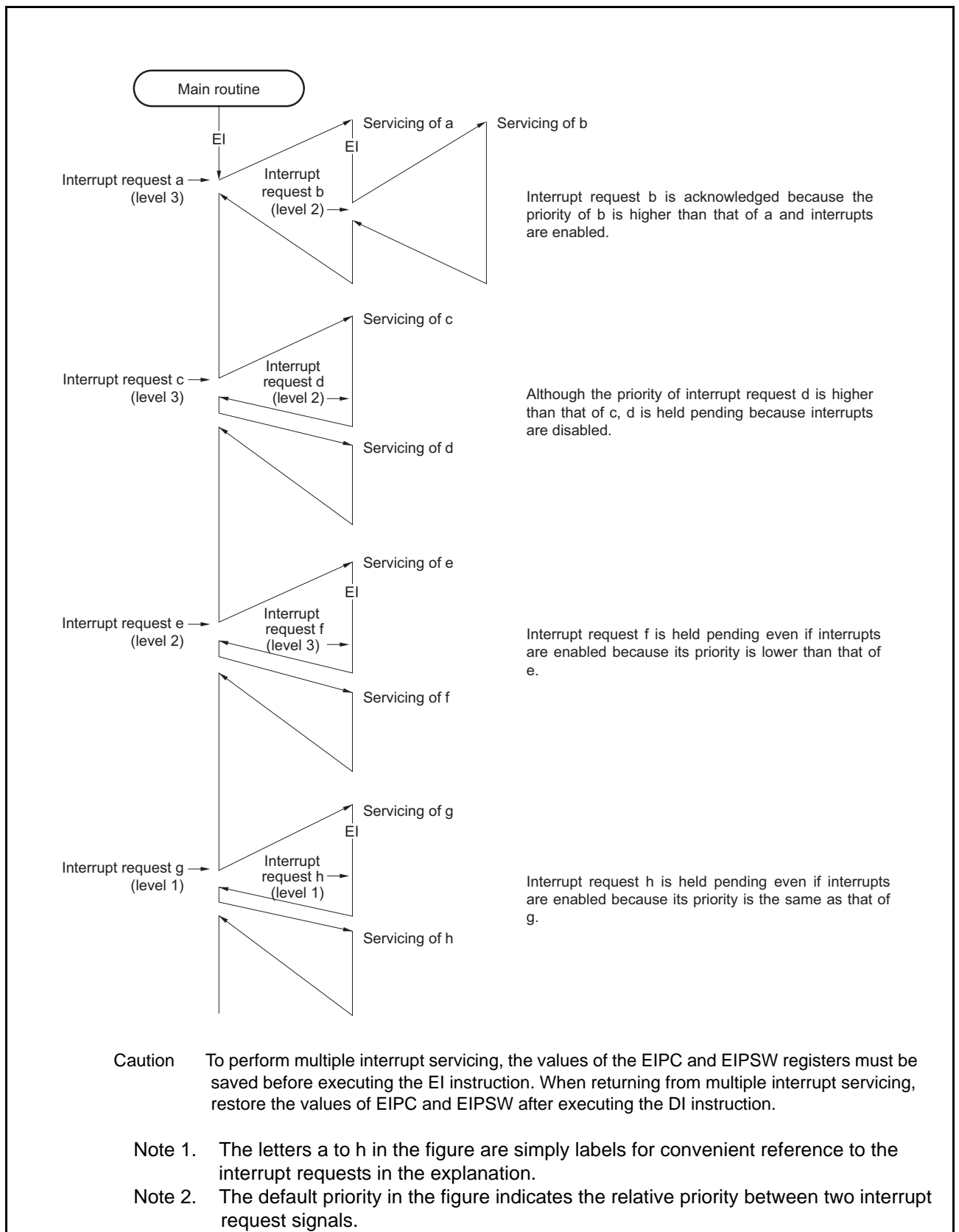

Figure 4-6 Example of Processing in which Another Interrupt Request Signal is Issued while an Interrupt is being Serviced (1/2)

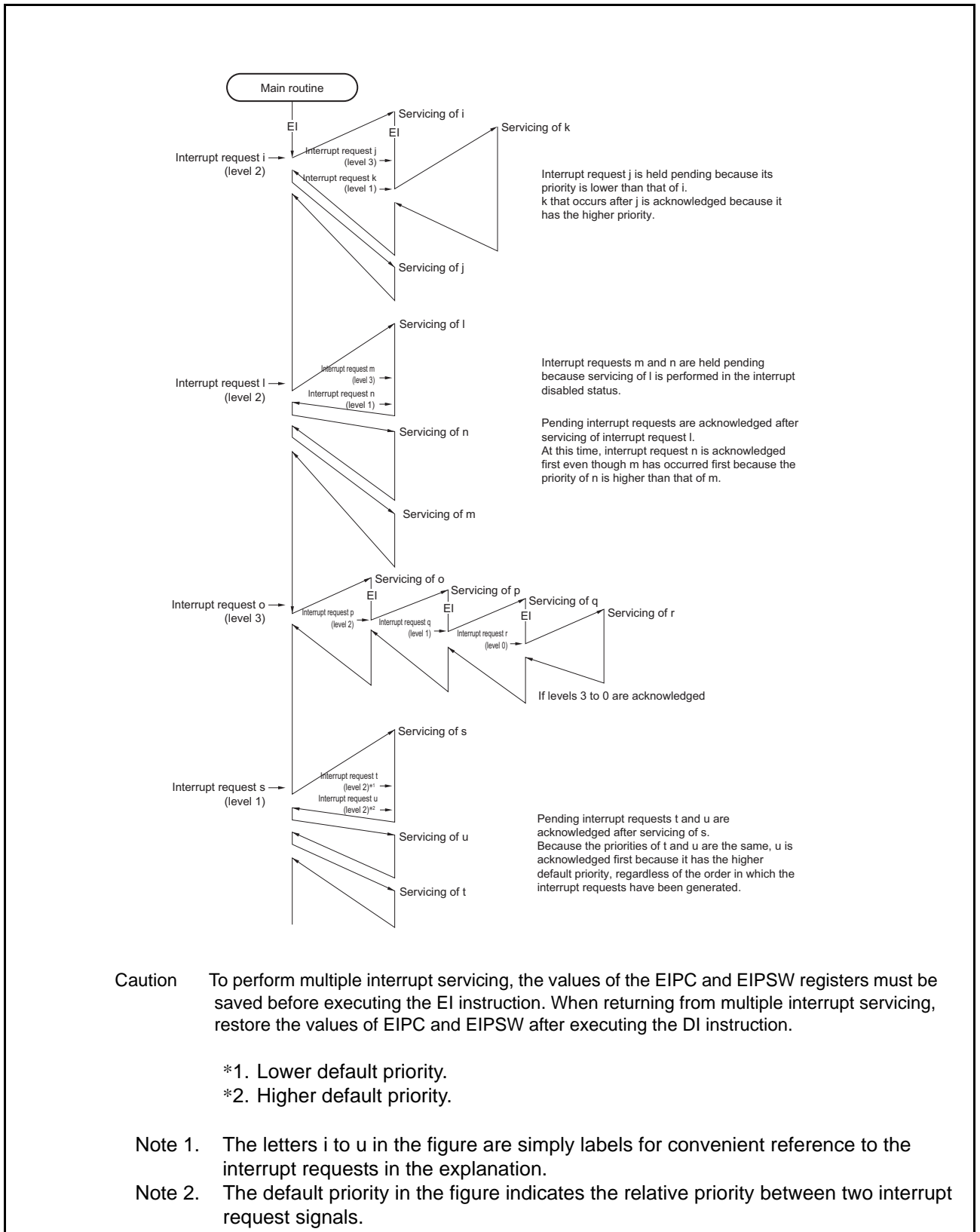

Figure 4-6 Example of Processing in which Another Interrupt Request Signal is Issued while an Interrupt is being Serviced (2/2)

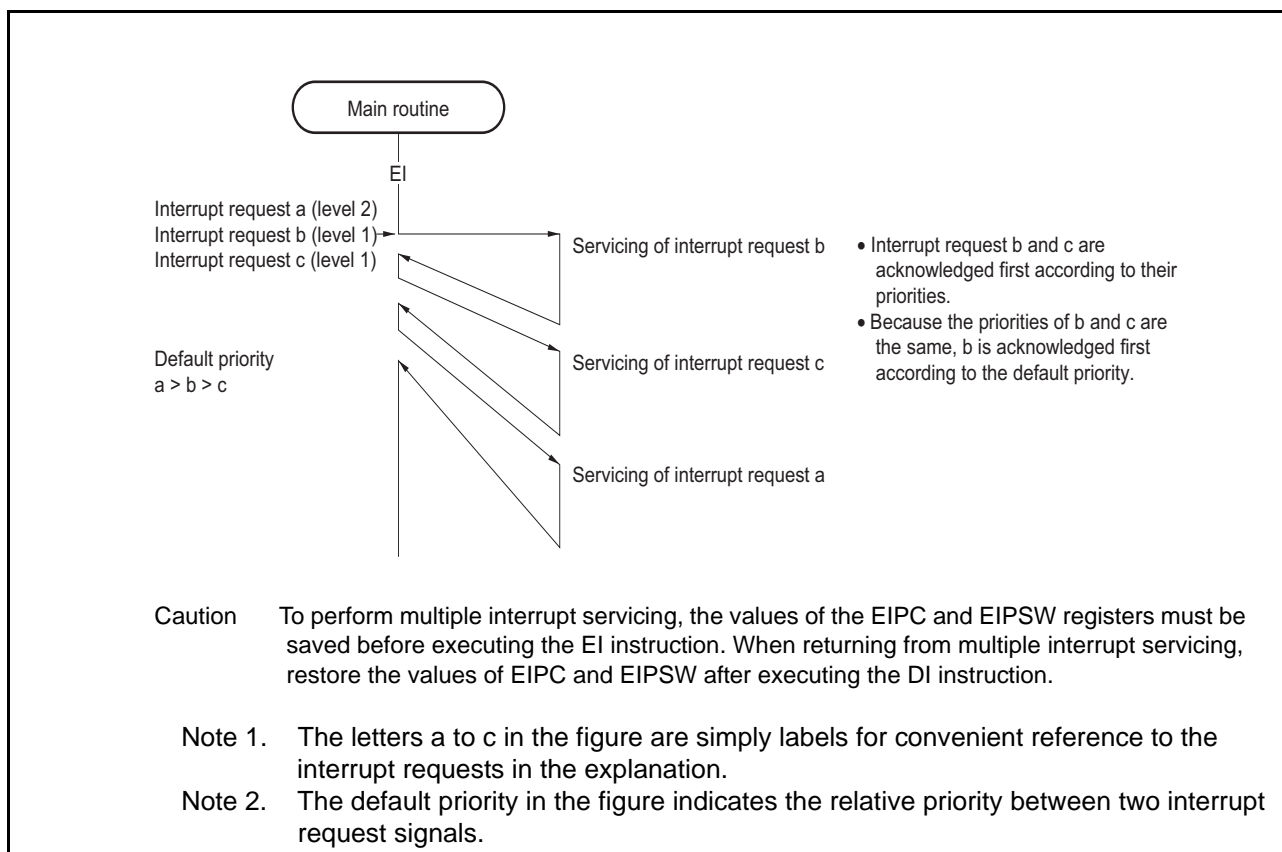

Figure 4-7 Example of Servicing Interrupt Request Signals Simultaneously Generated

4.5.3 Priority Mask Function

The priority mask function prohibits in batch EIINT interrupts of the specified interrupt priority level.

The interrupt masking priority level is specified with the PMR register. Masking and acknowledgment can be set for each priority level.

The following operations are possible using this function.

- Temporary prohibition of interrupts that have a priority level that is lower than a given priority level
- Temporary prohibition of interrupts that have a given priority level

PMR.PMRm	Operation
0	Acknowledges requests from priority level m interrupt source.
1	Masks requests from priority level m interrupt source.

Note: m = 0 to 15

The PMR register prohibits interrupt occurrence. Interrupt request is acknowledged and held even while the interrupt occurrence is prohibited.

The presence of EIINT interrupts held pending with this function can be checked with Section 4.5.4, Pending Interrupt Report Function.

4.5.4 Pending Interrupt Report Function

The state of the currently pending interrupt can be checked with the pending interrupt report function.

This function allows checking of the following states.

- When interrupts that are masked only by the priority mask function (PMR) exist

The ICSR.PMF bit is set to 1.

The only case where the ICSR.PMF bit is not set to 1 is when the setting in the ISPR register is masking interrupts at the given priority level or the interrupt is masked by settings of the ICxx.MKxx and IMRm.IMRmEIMKn bits. Thus, the existence of priority requests pended through the priority mask function can be checked while interrupts are prohibited through priority masking.

- When EI level maskable interrupt request is not output to the CPU

The ICSR.EIR bit is set to 1.

By looking at the ICSR.EIR bit in the interval during which PSW.ID = 1, it is possible to check whether an EIINT interrupt request exists.

- When FE level maskable interrupt request is not output to the CPU

ICSR.FIR bit is set to 1.

By looking at the ICSR.FIR bit in the interval during which PSW.NP = 1, it is possible to check whether a FEINT interrupt request exists.

4.5.5 In-Service Priority Clear Function

This function initializes the internal status of the interrupt controller. It operates when the ISPC register is accessed. The following operations are possible using this function.

- Clear all contents of ISPR register
- Clear ICSR.EIE, FIE, and FNE bits

All the bits of ISPR register can be cleared to 0 by writing "1" to all bits of this register and then writing "0" to all bits of ISPR. Moreover, the ICSR.EIE, FIE, and FNE bits, which all indicate state in which an interrupt request is being processed by the CPU core, are all cleared.

The value of the ISPC register is automatically cleared to 0 by writing 0 to all the bits of ISPR. The values of the bits of ISPR remain unchanged when the same value is not written to all of the bits.

4.6 Exception Handler Address Switching Function

Interrupt handler addresses can be switched by software.

For details, refer to V850E2M Architecture Manual (R01US0001E).

4.7 Interrupt Response Times

Response times from the generation of an interrupt request until activation of interrupt servicing are described below.

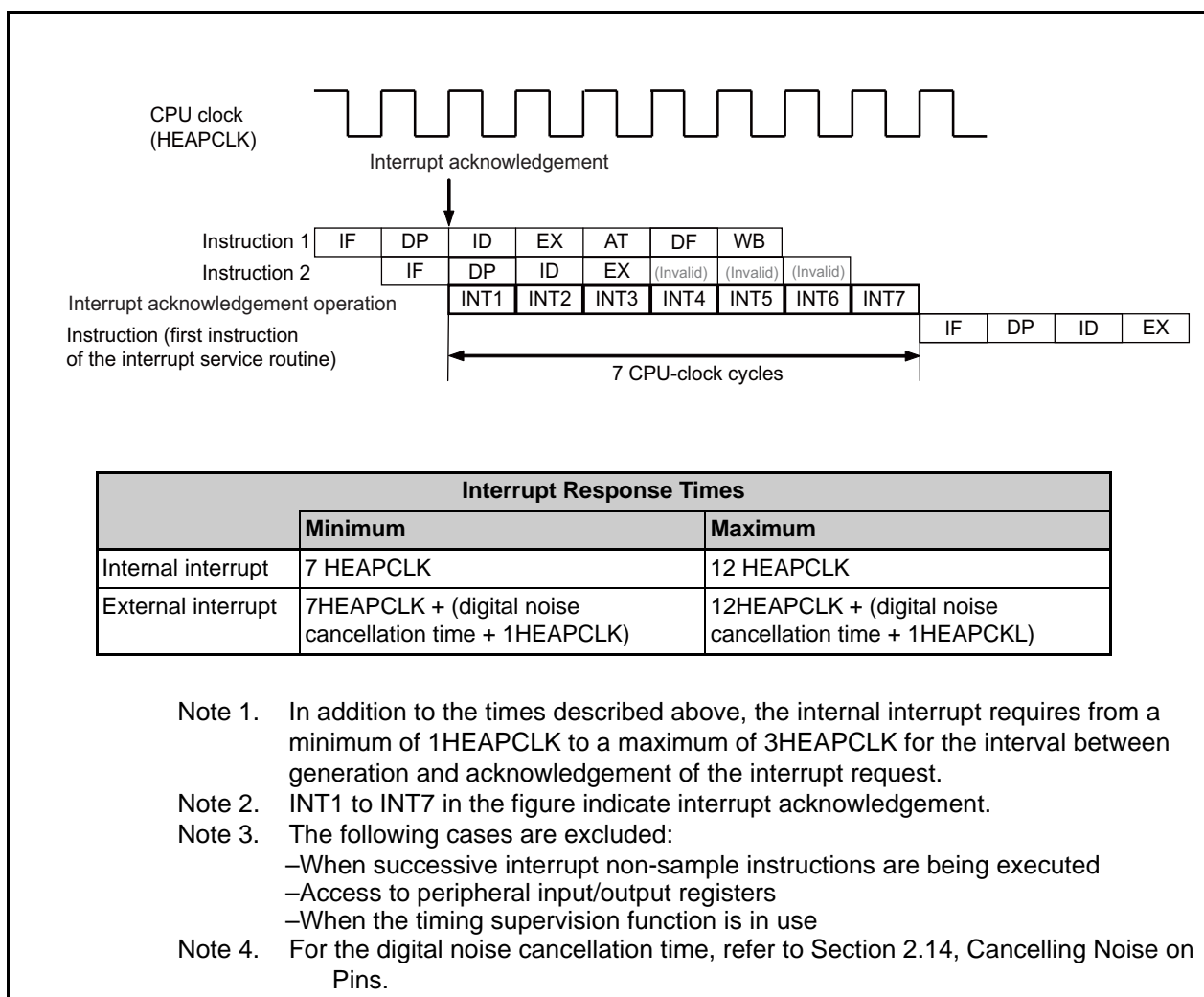

Figure 4-8 Pipeline Behavior on acknowledgement of an Interrupt Request (Outline)

Section 5 DMA Module

The direct memory access (DMA) module is described in this section.

5.1 DMA in Overview

DMA channels: This product has 8 DMA channels.

Instances index n, m, and l n, m, and l are used as shown below:

- For the DMA function, n indicates the channel numbers: n = 0 to 7.
- For the DMA function, m indicates the DMA trigger-source numbers: m = 0 to 107.
- For the DMA function: l indicates the highest number for a DMA trigger source: l = 107

(1) DMA Trigger Sources

Assignment of DMA trigger sources to DMA channel n is set by the DTFRn.IFC[6:0] bits.

All DMA trigger sources and the settings in the trigger source register (DTFRn) are listed in the following table.

Table 5-1 List of DMA Trigger Sources (1/3)

DIFRn.IFCn[6:0]								Register	DMA Trigger Source
6	5	4	3	2	1	0			
0	0	0	0	0	0	0	0	INTIN000	INTP0
0	0	0	0	0	0	1	1	INTIN001	INTP1
0	0	0	0	0	1	0	2	INTIN002	INTP2
0	0	0	0	0	1	1	3	INTIN003	INTP3
0	0	0	0	1	0	0	4	INTIN004	INTP4
0	0	0	0	1	0	1	5	INTIN005	INTP5
0	0	0	0	1	1	0	6	INTIN006	INTP6
0	0	0	0	1	1	1	7	INTIN007	INTP7
0	0	0	1	0	0	0	8	INTIN008	INTP8
0	0	0	1	0	0	1	9	INTIN009	INTP9
0	0	0	1	0	1	0	10	INTIN010	Reserved
0	0	0	1	0	1	1	11	INTIN011	INTDMA0
0	0	0	1	1	0	0	12	INTIN012	INTDMA1
0	0	0	1	1	0	1	13	INTIN013	INTDMA2
0	0	0	1	1	1	0	14	INTIN014	INTDMA3
0	0	0	1	1	1	1	15	INTIN015	INTDMA4
0	0	1	0	0	0	0	16	INTIN016	INTDMA5
0	0	1	0	0	0	1	17	INTIN017	INTDMA6
0	0	1	0	0	1	0	18	INTIN018	INTDMA7
0	0	1	0	0	1	1	19	INTIN019	INTTAUJ0I0
0	0	1	0	1	0	0	20	INTIN020	INTTAUJ0I1
0	0	1	0	1	0	1	21	INTIN021	INTTAUJ0I2
0	0	1	0	1	1	0	22	INTIN022	INTTAUJ0I3
0	0	1	0	1	1	1	23	INTIN023	Reserved
0	0	1	1	0	0	0	24	INTIN024	Reserved
0	0	1	1	0	0	1	25	INTIN025	Reserved
0	0	1	1	0	1	0	26	INTIN026	Reserved
0	0	1	1	0	1	1	27	INTIN027	INTTAUB0I0
0	0	1	1	1	0	0	28	INTIN028	INTTAUB0I1
0	0	1	1	1	0	1	29	INTIN029	INTTAUB0I2
0	0	1	1	1	1	0	30	INTIN030	INTTAUB0I3
0	0	1	1	1	1	1	31	INTIN031	INTTAUB0I4
0	1	0	0	0	0	0	32	INTIN032	INTTAUB0I5
0	1	0	0	0	0	1	33	INTIN033	INTTAUB0I6
0	1	0	0	0	1	0	34	INTIN034	INTTAUB0I7
0	1	0	0	0	1	1	35	INTIN035	INTTAUB0I8
0	1	0	0	1	0	0	36	INTIN036	INTTAUB0I9
0	1	0	0	1	0	1	37	INTIN037	INTTAUB0I10
0	1	0	0	1	1	0	38	INTIN038	INTTAUB0I11
0	1	0	0	1	1	1	39	INTIN039	INTTAUB0I12

Table 5-1 List of DMA Trigger Sources (2/3)

DTRn.IFCn[6:0]								Register	DMA Trigger Source
6	5	4	3	2	1	0			
0	1	0	1	0	0	0	40	INTIN040	INTTAUB013
0	1	0	1	0	0	1	41	INTIN041	INTTAUB014
0	1	0	1	0	1	0	42	INTIN042	INTTAUB015
0	1	0	1	0	1	1	43	INTIN043	Reserved
0	1	0	1	1	0	0	44	INTIN044	Reserved
0	1	0	1	1	0	1	45	INTIN045	Reserved
0	1	0	1	1	1	0	46	INTIN046	Reserved
0	1	0	1	1	1	1	47	INTIN047	Reserved
0	1	1	0	0	0	0	48	INTIN048	Reserved
0	1	1	0	0	0	1	49	INTIN049	Reserved
0	1	1	0	0	1	0	50	INTIN050	Reserved
0	1	1	0	0	1	1	51	INTIN051	Reserved
0	1	1	0	1	0	0	52	INTIN052	Reserved
0	1	1	0	1	0	1	53	INTIN053	Reserved
0	1	1	0	1	1	0	54	INTIN054	Reserved
0	1	1	0	1	1	1	55	INTIN055	Reserved
0	1	1	1	0	0	0	56	INTIN056	Reserved
0	1	1	1	0	0	1	57	INTIN057	Reserved
0	1	1	1	0	1	0	58	INTIN058	Reserved
0	1	1	1	0	1	1	59	INTIN059	INTADCA0ERR
0	1	1	1	1	0	0	60	INTIN060	INTADCA0I0
0	1	1	1	1	0	1	61	INTIN061	INTADCA0I1
0	1	1	1	1	1	0	62	INTIN062	INTADCA0I2
0	1	1	1	1	1	1	63	INTIN063	Reserved
1	0	0	0	0	0	0	64	INTIN064	Reserved
1	0	0	0	0	0	1	65	INTIN065	Reserved
1	0	0	0	0	1	0	66	INTIN066	Reserved
1	0	0	0	0	1	1	67	INTIN067	Reserved
1	0	0	0	1	0	0	68	INTIN068	Reserved
1	0	0	0	1	0	1	69	INTIN069	INTCSIG0IR
1	0	0	0	1	1	0	70	INTIN070	INTCSIG0IC
1	0	0	0	1	1	1	71	INTIN071	INTCSIG1IR
1	0	0	1	0	0	0	72	INTIN072	INTCSIG1IC
1	0	0	1	0	0	1	73	INTIN073	Reserved
1	0	0	1	0	1	0	74	INTIN074	Reserved
1	0	0	1	0	1	1	75	INTIN075	INTURTH0IS
1	0	0	1	1	0	0	76	INTIN076	INTURTH0IR
1	0	0	1	1	0	1	77	INTIN077	INTURTH0IT
1	0	0	1	1	1	0	78	INTIN078	INTURTH1IS
1	0	0	1	1	1	1	79	INTIN079	INTURTH1IR

Table 5-1 List of DMA Trigger Sources (3/3)

DIFRn.IFCn[6:0]								Register	DMA Trigger Source
6	5	4	3	2	1	0			
1	0	1	0	0	0	0	80	INTIN080	INTURTH1IT
1	0	1	0	0	0	1	81	INTIN081	Reserved
1	0	1	0	0	1	0	82	INTIN082	Reserved
1	0	1	0	0	1	1	83	INTIN083	Reserved
1	0	1	0	1	0	0	84	INTIN084	INTTSG20I11
1	0	1	0	1	0	1	85	INTIN085	INTTSG20I12
1	0	1	0	1	1	0	86	INTIN086	INTTSG20IPEK
1	0	1	0	1	1	1	87	INTIN087	INTTSG20IVLY
1	0	1	1	0	0	0	88	INTIN088	Reserved
1	0	1	1	0	0	1	89	INTIN089	Reserved
1	0	1	1	0	1	0	90	INTIN090	Reserved
1	0	1	1	0	1	1	91	INTIN091	Reserved
1	0	1	1	1	0	0	92	INTIN092	INTENCA0IOV
1	0	1	1	1	0	1	93	INTIN093	INTENCA0IO
1	0	1	1	1	1	0	94	INTIN094	INTENCA0I1
1	0	1	1	1	1	1	95	INTIN095	INTENCA0IUD
1	1	0	0	0	0	0	96	INTIN096	INTENCA0IEC
1	1	0	0	0	0	1	97	INTIN097	Reserved
1	1	0	0	0	1	0	98	INTIN098	Reserved
1	1	0	0	0	1	1	99	INTIN099	Reserved
1	1	0	0	1	0	0	100	INTIN100	Reserved
1	1	0	0	1	0	1	101	INTIN101	Reserved
1	1	0	0	1	1	0	102	INTIN102	INTTPBA0IPRD
1	1	0	0	1	1	1	103	INTIN103	INTTPBA0IDTY
1	1	0	1	0	0	0	104	INTIN104	INTTPBA0IPAT
1	1	0	1	0	0	1	105	INTIN105	Reserved
1	1	0	1	0	1	0	106	INTIN106	Reserved
1	1	0	1	0	1	1	107	INTIN107	Reserved

5.2 Definitions

The following terms are defined for use in this section,.

Table 5-2 List of Term Definitions

Terms	Meaning
DMA transfer	The period from the start of a DMA cycle until assertion of INTDMA
DMA cycle	Period taken to transfer a single transfer unit once, from the start of the cycle of reading by the on-chip system bus to completion of the write cycle. In the case of 128-bit transfer, completion takes 4 cycles of reading or 4 cycles of writing.
Hardware DMA transfer request	DMA transfer request in the form of any interrupt signal
Software DMA transfer request	DMA transfer request through an internal register (the DTSnSR bit in DTSn register)
DMA transfer request	Hardware DMA transfer request or software DMA transfer request
Single transfer	The DMAC executes a single DMA cycle per transfer request.
Single-step transfer	The number of transfers specified by the transfer count setting register (DTCn) is executed per software DMA transfer request. Since the bus is released after each transfer, the CPU is able to generate interrupts. When a transfer request with higher priority is received during single-step transfer, single-step transfer is stopped and execution of the higher-priority request proceeds.

5.3 Overview

Direct memory access (DMA) is used to access data without going through the CPU.

Internally, the subsystem of this product consists of two units: the DMAC and DTFR (DMA trigger factor register).

The DMAC is capable of transferring data at high speeds using the internal system bus.

The DTFR has the function of selecting DMA transfer sources from interrupt requests.

5.3.1 Functions of the DMA Controller (DMAC)

- The DMAC includes registers for storing transfer information (transfer address, transfer unit size, etc.) and for control.
- When a DMA transfer request is accepted, a transfer request is output to the DMAT, according to the transfer information it contains.
- Hardware DMA transfer requests, DMA acknowledge signals, and DMA transfer completion interrupts are input and output.
- Write-back information is written back to the registers.

5.3.2 Function of the DMA Trigger Factor Register (DTFR)

- This register selects DMA transfer sources from among the interrupt signals (triggers for the 8 channels are selected from among the $m = 108$ interrupt signals).

Table 5-3 Target Spaces for DMA Transfer

Source \ Destination	Peripheral I/O (PBUS)	On-chip RAM	On-Chip Code Flash	On-Chip Data Flash
Peripheral I/O (PBUS)	OK	OK	NG	NG
On-chip RAM	OK	OK	NG	NG
On-chip code flash	OK	OK	NG	NG
On-chip data flash	OK	OK	NG	NG

Note For the addresses of the target areas for transfer, refer to Figure 5-2, Memory Map as Seen from the DMA.

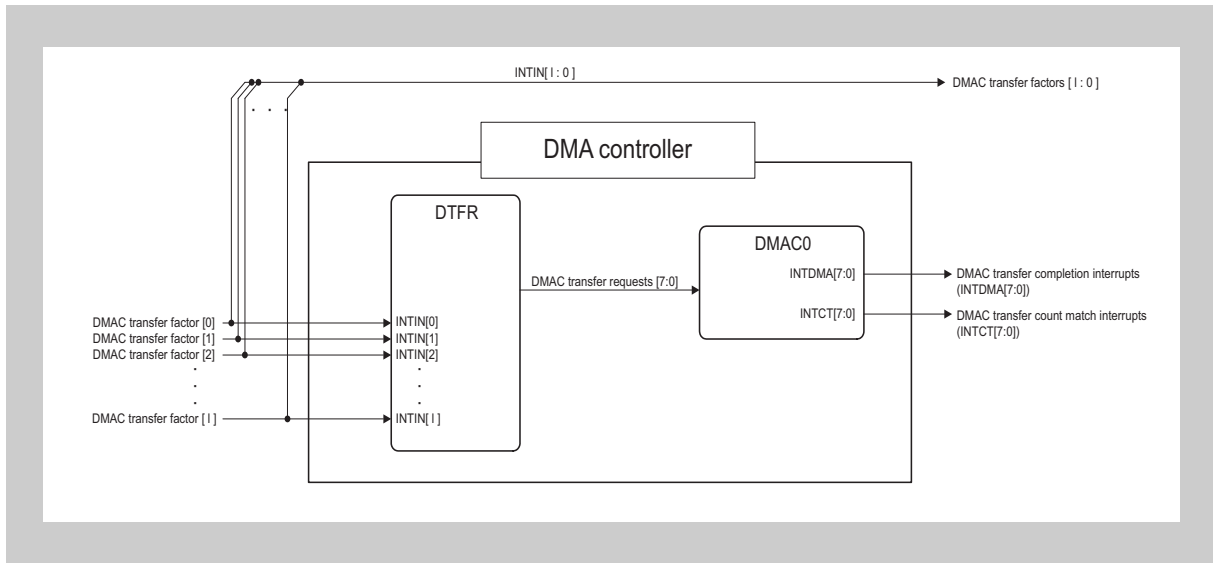

Figure 5-1 Connection of Interrupt Signals

5.3.3 Memory Map for DMA Access

A memory map of the areas accessible by the DMA is given below.

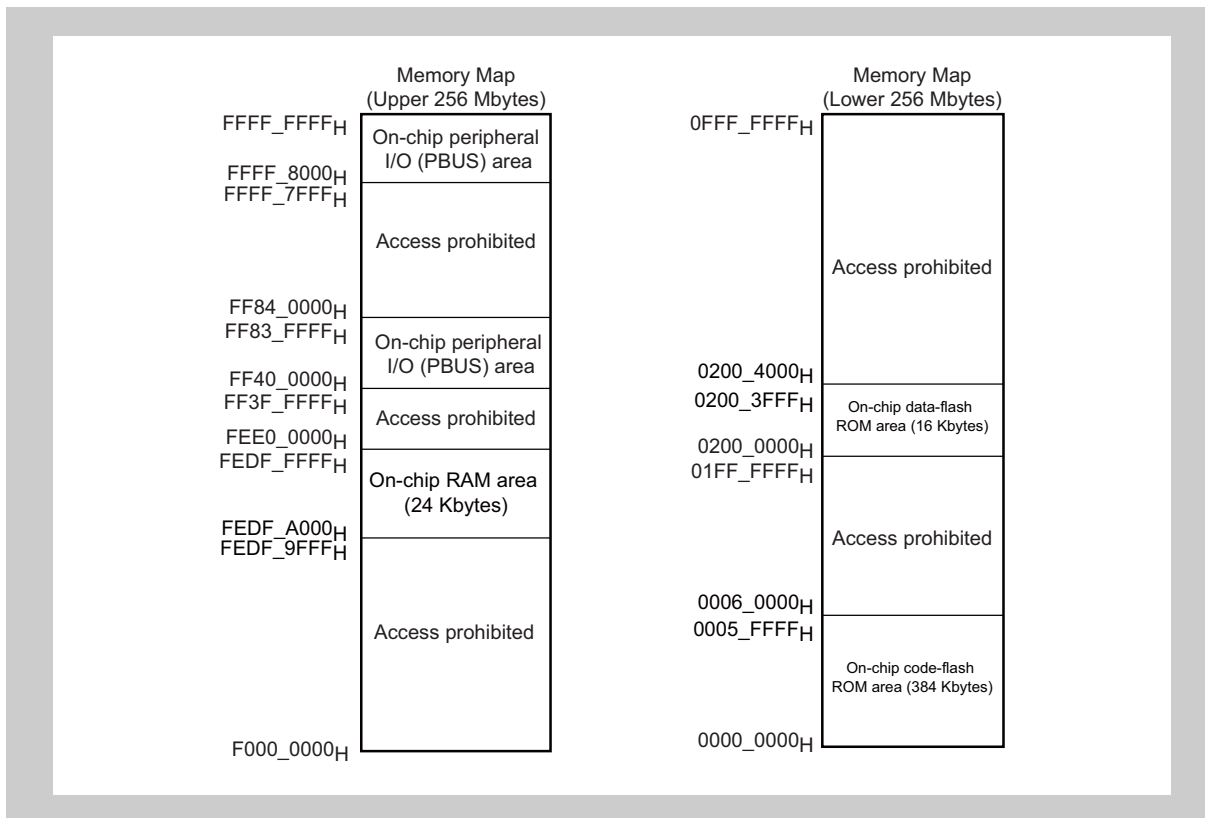

Figure 5-2 Memory Map as Seen from the DMA

5.3.4 Channel Priority

The priority is fixed and follows this relation: CH0 > CH1 > CH2 > CH3 > CH4 > CH5 > CH6 > CH7. Accordingly, CH0 has the top priority.

5.4 DMAC Function

5.4.1 Characteristics

Channels	8 (0 channel to 7 channel)
Unit of data transfer	8 bits 16 bits 32 bits 128 bits
Caution	When data-flash memory is selected as the source for transfer, specify the unit of data transfer as 32 or 128 bits.
Transfer data	Fixed to little endian Misaligned data are not supported.
Maximum transfer count	32768(2^{15}) times (the highest order bit of the 16-bit register is used for next address function)
Channel priority control	Fixed priority (highest priority (CH0) → lowest priority (CH7))
Targets for transfer	Code-flash On-chip RAM Data-flash Peripheral I/O area
Transfer type	Two-cycle transfer (dual-address transfer) The addresses at both the transfer source and destination are accessed. Two bus cycles are required to execute transfer once (read cycles + write cycles). The bus is not locked between the read cycles and write cycles, so processing can be interrupted to insert a different cycle of transfer. Also, 128-bit access requires the execution of 4 bus cycles of reading followed by 4 bus cycles of writing. The bus is not locked between the cycles of reading and the cycles of writing, so processing for this transfer may be interrupted at this time.

Transfer mode	<ul style="list-style-type: none"> • Single transfer mode (when a hardware DMA transfer request is generated) When a hardware DMA transfer request is generated, the controller acquires bus mastership and then releases the bus after one cycle of transfer. If another hardware DMA transfer request is subsequently generated, transfer is executed again. This operation is repeated until transfer has been executed the number of times specified in the transfer count register (DTCn). • Single-step transfer mode (when a software DMA transfer request is generated) When a software DMA transfer request is generated, the bus mastership is acquired, and the bus is released per unit transfer. Once a software DMA transfer request has been acknowledged, this operation is repeated until unit transfers have been executed the number of times specified by the transfer count register (DTCn).
Transfer address control	<p>Incrementation</p> <p>Decrementation</p> <p>Fixed</p>
Transfer error support	When the data from the transfer source contains an error or an error occurs at the transfer destination, DMA transfer is stopped and a SysError exception is issued to notify the CPU.
DMA transfer request	A hardware DMA transfer request or software DMA transfer request can be selected for each channel (by setting the DTRSn register). A software DMA transfer request can be set by software (by setting the DTS register). This register also has a status bit (DTS register) to indicate when a hardware DMA transfer request has been generated.
Interrupt output upon a match of transfer count	This function has a transfer count compare register (DTCCn) for each channel and outputs an interrupt signal (INTDMACT7 to INTDMACT0) when the value in this register matches that in the transfer count register (DTCn) for any channel.
Interrupt output on completion of transfer	This function outputs a transfer completion interrupt signal (INTDMA7 to INTDMA0) when DMA unit transfer on any channel has been completed the number of times specified in the transfer count register (DTCn).
Next address setting	Setting of the next address is handled by equipping each channel with two sets of registers: one for setting the transfer address and transfer count (current transfer registers) of the DMA transfer currently being executed, and the other for setting the transfer address and transfer count (next transfer registers) for the next DMA transfer, i.e. that will follow completion of the DMA transfer that is currently in progress. The registers also have a bit for setting whether to copy values from the “next” to the “current” registers on completion of DMA transfer.
DMA transfer suspension	This function supports DMA transfer suspension by software.

5.4.2 Setting Registers

Table 5-4 DMAC Setting Registers (1/5)

Address	Symbol	Register Name	R/W	Bit Width for Operations				Initial Value
				1	8	16	32	
FFFF7300 _H	DTRC0	DMA transfer request control register 0	R/W	√	√			00 _H
FFFF7310 _H	DTRS0	DMA transfer request select register CH0				√		0000 _H
FFFF7314 _H	DSA0	DMA source address register CH0					√	00000000 _H
FFFF7314 _H	DSA0L	DMA source address register LCH0			√			0000 _H
FFFF7316 _H	DSA0H	DMA source address register HCH0			√			0000 _H
FFFF7318 _H	DSC0	DMA source chip select register CH0			√			0001 _H
FFFF731C _H	DNSA0	DMA next source address register CH0					√	00000000 _H
FFFF731C _H	DNSA0L	DMA next source address register LCH0			√			0000 _H
FFFF731E _H	DNSA0H	DMA next source address register HCH0			√			0000 _H
FFFF7320 _H	DNSC0	DMA next source chip select register CH0			√			0001 _H
FFFF7324 _H	DDA0	DMA destination address register CH0					√	00000000 _H
FFFF7324 _H	DDA0L	DMA destination address register LCH0			√			0000 _H
FFFF7326 _H	DDA0H	DMA destination address register HCH0			√			0000 _H
FFFF7328 _H	DDC0	DMA destination chip select register CH0			√			0001 _H
FFFF732C _H	DNDA0	DMA next destination address register CH0					√	00000000 _H
FFFF732C _H	DNDA0L	DMA next destination address register LCH0			√			0000 _H
FFFF732E _H	DNDA0H	DMA next destination address register HCH0			√			0000 _H
FFFF7330 _H	DNDC0	DMA next destination chip select register CH0			√			0001 _H
FFFF7332 _H	DTC0	DMA transfer count register CH0			√			0000 _H
FFFF7334 _H	DNTC0	DMA next transfer count register CH0			√			0000 _H
FFFF7336 _H	DTCC0	DMA transfer count compare register CH0			√			0000 _H
FFFF7338 _H	DTCT0	DMA transfer control register CH0			√			0000 _H
FFFF733A _H	DTS0	DMA transfer status register CH0		√	√			00 _H
FFFF7340 _H	DTRS1	DMA transfer request select register CH1				√		0000 _H
FFFF7344 _H	DSA1	DMA source address register CH1					√	00000000 _H
FFFF7344 _H	DSA1L	DMA source address register LCH1			√			0000 _H
FFFF7346 _H	DSA1H	DMA source address register HCH1			√			0000 _H
FFFF7348 _H	DSC1	DMA source chip select register CH1			√			0001 _H
FFFF734C _H	DNSA1	DMA next source address register CH1					√	00000000 _H
FFFF734C _H	DNSA1L	DMA next source address register LCH1			√			0000 _H
FFFF734E _H	DNSA1H	DMA next source address register HCH1			√			0000 _H
FFFF7350 _H	DNSC1	DMA next source chip select register CH1			√			0001 _H
FFFF7354 _H	DDA1	DMA destination address register CH1					√	00000000 _H
FFFF7354 _H	DDA1L	DMA destination address register LCH1			√			0000 _H
FFFF7356 _H	DDA1H	DMA destination address register HCH1			√			0000 _H
FFFF7358 _H	DDC1	DMA destination chip select register CH1			√			0001 _H

Table 5-4 DMAC Setting Registers (2/5)

Address	Symbol	Register Name	R/W	Bit Width for Operations				Initial Value
				1	8	16	32	
FFFF735C _H	DNDA1	DMA next destination address register CH1	R/W				√	00000000 _H
FFFF735C _H	DNDA1L	DMA next destination address register LCH1				√		0000 _H
FFFF735E _H	DNDA1H	DMA next destination address register HCH1				√		0000 _H
FFFF7360 _H	DNDC1	DMA next destination chip select register CH1			√			0001 _H
FFFF7362 _H	DTC1	DMA transfer count register CH1			√			0000 _H
FFFF7364 _H	DNTC1	DMA next transfer count register CH1			√			0000 _H
FFFF7366 _H	DTCC1	DMA transfer count compare register CH1			√			0000 _H
FFFF7368 _H	DTCT1	DMA transfer control register CH1			√			0000 _H
FFFF736A _H	DTS1	DMA transfer status register CH1		√	√			00 _H
FFFF7370 _H	DTRS2	DMA transfer request select register CH2				√		0000 _H
FFFF7374 _H	DSA2	DMA source address register CH2					√	00000000 _H
FFFF7374 _H	DSA2L	DMA source address register LCH2				√		0000 _H
FFFF7376 _H	DSA2H	DMA source address register HCH2				√		0000 _H
FFFF7378 _H	DSC2	DMA source chip select register CH2				√		0001 _H
FFFF737C _H	DNSA2	DMA next source address register CH2					√	00000000 _H
FFFF737C _H	DNSA2L	DMA next source address register LCH2				√		0000 _H
FFFF737E _H	DNSA2H	DMA next source address register HCH2				√		0000 _H
FFFF7380 _H	DNDC2	DMA next source chip select register CH2				√		0001 _H
FFFF7384 _H	DDA2	DMA destination address register CH2					√	00000000 _H
FFFF7384 _H	DDA2L	DMA destination address register LCH2				√		0000 _H
FFFF7386 _H	DDA2H	DMA destination address register HCH2				√		0000 _H
FFFF7388 _H	DDC2	DMA destination chip select register CH2				√		0001 _H
FFFF738C _H	DNDA2	DMA next destination address register CH2					√	00000000 _H
FFFF738C _H	DNDA2L	DMA next destination address register LCH2				√		0000 _H
FFFF738E _H	DNDA2H	DMA next destination address register HCH2				√		0000 _H
FFFF7390 _H	DNDC2	DMA next destination chip select register CH2				√		0001 _H
FFFF7392 _H	DTC2	DMA transfer count register CH2				√		0000 _H
FFFF7394 _H	DNTC2	DMA next transfer count register CH2				√		0000 _H
FFFF7396 _H	DTCC2	DMA transfer count compare register CH2				√		0000 _H
FFFF7398 _H	DTCT2	DMA transfer control register CH2				√		0000 _H
FFFF739A _H	DTS2	DMA transfer status register CH2		√	√			00 _H
FFFF73A0 _H	DTRS3	DMA transfer request select register CH3				√		0000 _H
FFFF73A4 _H	DSA3	DMA source address register CH3					√	00000000 _H
FFFF73A4 _H	DSA3L	DMA source address register LCH3				√		0000 _H
FFFF73A6 _H	DSA3H	DMA source address register HCH3				√		0000 _H
FFFF73A8 _H	DSC3	DMA source chip select register CH3				√		0001 _H

Table 5-4 DMAC Setting Registers (3/5)

Address	Symbol	Register Name	R/W	Bit Width for Operations				Initial Value
				1	8	16	32	
FFFF73AC _H	DNSA3	DMA next source address register CH3	R/W				√	00000000 _H
FFFF73AC _H	DNSA3L	DMA next source address register LCH3				√		0000 _H
FFFF73AE _H	DNSA3H	DMA next source address register HCH3				√		0000 _H
FFFF73B0 _H	DN3C3	DMA next source chip select register CH3				√		0001 _H
FFFF73B4 _H	DDA3	DMA destination address register CH3					√	00000000 _H
FFFF73B4 _H	DDA3L	DMA destination address register LCH3				√		0000 _H
FFFF73B6 _H	DDA3H	DMA destination address register HCH3				√		0000 _H
FFFF73B8 _H	DDC3	DMA destination chip select register CH3				√		0001 _H
FFFF73BC _H	DNDA3	DMA next destination address register CH3					√	00000000 _H
FFFF73BC _H	DNDA3L	DMA next destination address register LCH3				√		0000 _H
FFFF73BE _H	DNDA3H	DMA next destination address register HCH3				√		0000 _H
FFFF73C0 _H	DNDC3	DMA next destination chip select register CH3				√		0001 _H
FFFF73C2 _H	DTC3	DMA transfer count register CH3				√		0000 _H
FFFF73C4 _H	DNTC3	DMA next transfer count register CH3				√		0000 _H
FFFF73C6 _H	DTCC3	DMA transfer count compare register CH3				√		0000 _H
FFFF73C8 _H	DTCT3	DMA transfer control register CH3				√		0000 _H
FFFF73CA _H	DTS3	DMA transfer status register CH3		√	√			00 _H
FFFF73D0 _H	DTRS4	DMA transfer request select register CH4				√		0000 _H
FFFF73D4 _H	DSA4	DMA source address register CH4					√	00000000 _H
FFFF73D4 _H	DSA4L	DMA source address register LCH4				√		0000 _H
FFFF73D6 _H	DSA4H	DMA source address register HCH4			√		0000 _H	
FFFF73D8 _H	DSC4	DMA source chip select register CH4			√		0001 _H	
FFFF73DC _H	DNSA4	DMA next source address register CH4				√	00000000 _H	
FFFF73DC _H	DNSA4L	DMA next source address register LCH4			√		0000 _H	
FFFF73DE _H	DNSA4H	DMA next source address register HCH4			√		0000 _H	
FFFF73E0 _H	DN3C4	DMA next source chip select register CH4			√		0001 _H	
FFFF73E4 _H	DDA4	DMA destination address register CH4				√	00000000 _H	
FFFF73E4 _H	DDA4L	DMA destination address register LCH4			√		0000 _H	
FFFF73E6 _H	DDA4H	DMA destination address register HCH4			√		0000 _H	
FFFF73E8 _H	DDC4	DMA destination chip select register CH4			√		0001 _H	
FFFF73EC _H	DNDA4	DMA next destination address register CH4				√	00000000 _H	
FFFF73EC _H	DNDA4L	DMA next destination address register LCH4			√		0000 _H	
FFFF73EE _H	DNDA4H	DMA next destination address register HCH4			√		0000 _H	
FFFF73F0 _H	DNDC4	DMA next destination chip select register CH4			√		0001 _H	
FFFF73F2 _H	DTC4	DMA transfer count register CH4			√		0000 _H	
FFFF73F4 _H	DNTC4	DMA next transfer count register CH4			√		0000 _H	

Table 5-4 DMAC Setting Registers (4/5)

Address	Symbol	Register Name	R/W	Bit Width for Operations				Initial Value
				1	8	16	32	
FFFF73F6 _H	DTCC4	DMA transfer count compare register CH4	R/W			√		0000 _H
FFFF73F8 _H	DTCT4	DMA transfer control register CH4				√		0000 _H
FFFF73FA _H	DTS4	DMA transfer status register CH4		√	√			00 _H
FFFF7400 _H	DTRS5	DMA transfer request select register CH5				√		0000 _H
FFFF7404 _H	DSA5	DMA source address register CH5					√	00000000 _H
FFFF7404 _H	DSA5L	DMA source address register LCH5				√		0000 _H
FFFF7406 _H	DSA5H	DMA source address register HCH5				√		0000 _H
FFFF7408 _H	DSC5	DMA source chip select register CH5				√		0001 _H
FFFF740C _H	DNSA5	DMA next source address register CH5					√	00000000 _H
FFFF740C _H	DNSA5L	DMA next source address register LCH5				√		0000 _H
FFFF740E _H	DNSA5H	DMA next source address register HCH5				√		0000 _H
FFFF7410 _H	DN5C5	DMA next source chip select register CH5				√		0001 _H
FFFF7414 _H	DDA5	DMA destination address register CH5					√	00000000 _H
FFFF7414 _H	DDA5L	DMA destination address register LCH5				√		0000 _H
FFFF7416 _H	DDA5H	DMA destination address register HCH5				√		0000 _H
FFFF7418 _H	DDC5	DMA destination chip select register CH5				√		0001 _H
FFFF741C _H	DNDA5	DMA next destination address register CH5					√	00000000 _H
FFFF741C _H	DNDA5L	DMA next destination address register LCH5				√		0000 _H
FFFF741E _H	DNDA5H	DMA next destination address register HCH5				√		0000 _H
FFFF7420 _H	DNDC5	DMA next destination chip select register CH5				√		0001 _H
FFFF7422 _H	DTC5	DMA transfer count register CH5				√		0000 _H
FFFF7424 _H	DN5TC5	DMA next transfer count register CH5				√		0000 _H
FFFF7426 _H	DTCC5	DMA transfer count compare register CH5				√		0000 _H
FFFF7428 _H	DTCT5	DMA transfer control register CH5				√		0000 _H
FFFF742A _H	DTS5	DMA transfer status register CH5		√	√			00 _H
FFFF7430 _H	DTRS6	DMA transfer request select register CH6				√		0000 _H
FFFF7434 _H	DSA6	DMA source address register CH6					√	00000000 _H
FFFF7434 _H	DSA6L	DMA source address register LCH6				√		0000 _H
FFFF7436 _H	DSA6H	DMA source address register HCH6				√		0000 _H
FFFF7438 _H	DSC6	DMA source chip select register CH6				√		0001 _H
FFFF743C _H	DNSA6	DMA next source address register CH6					√	00000000 _H
FFFF743C _H	DNSA6L	DMA next source address register LCH6				√		0000 _H
FFFF743E _H	DNSA6H	DMA next source address register HCH6				√		0000 _H
FFFF7440 _H	DN5C6	DMA next source chip select register CH6				√		0001 _H
FFFF7444 _H	DDA6	DMA destination address register CH6					√	00000000 _H
FFFF7444 _H	DDA6L	DMA destination address register LCH6				√		0000 _H
FFFF7446 _H	DDA6H	DMA destination address register HCH6				√		0000 _H

Table 5-4 DMAC Setting Registers (5/5)

Address	Symbol	Register Name	R/W	Bit Width for Operations				Initial Value	
				1	8	16	32		
FFFF7448 _H	DDC6	DMA destination chip select register CH6	R/W			√		0001 _H	
FFFF744C _H	DNDA6	DMA next destination address register CH6					√		00000000 _H
FFFF744C _H	DNDA6L	DMA next destination address register LCH6				√			0000 _H
FFFF744E _H	DNDA6H	DMA next destination address register HCH6				√			0000 _H
FFFF7450 _H	DNDC6	DMA next destination chip select register CH6				√			0001 _H
FFFF7452 _H	DTC6	DMA transfer count register CH6				√			0000 _H
FFFF7454 _H	DNTC6	DMA next transfer count register CH6				√			0000 _H
FFFF7456 _H	DTCC6	DMA transfer count compare register CH6				√			0000 _H
FFFF7458 _H	DTCT6	DMA transfer control register CH6				√			0000 _H
FFFF745A _H	DTS6	DMA transfer status register CH6		√	√				00 _H
FFFF7460 _H	DTRS7	DMA transfer request select register CH7				√			0000 _H
FFFF7464 _H	DSA7	DMA source address register CH7					√		00000000 _H
FFFF7464 _H	DSA7L	DMA source address register LCH7				√			0000 _H
FFFF7466 _H	DSA7H	DMA source address register LCH7				√			0000 _H
FFFF7468 _H	DSC7	DMA source chip select register CH7				√			0001 _H
FFFF746C _H	DNSA7	DMA next source address register CH7					√		00000000 _H
FFFF746C _H	DNSA7L	DMA next source address register LCH7				√			0000 _H
FFFF746E _H	DNSA7H	DMA next source address register HCH7				√			0000 _H
FFFF7470 _H	DNDC7	DMA next source chip select register CH7				√			0001 _H
FFFF7474 _H	DDA7	DMA destination address register CH7					√		00000000 _H
FFFF7474 _H	DDA7L	DMA destination address register LCH7			√			0000 _H	
FFFF7476 _H	DDA7H	DMA destination address register HCH7			√			0000 _H	
FFFF7478 _H	DDC7	DMA destination chip select register CH7			√			0001 _H	
FFFF747C _H	DNDA7	DMA next destination address register CH7				√		00000000 _H	
FFFF747C _H	DNDA7L	DMA next destination address register LCH7			√			0000 _H	
FFFF747E _H	DNDA7H	DMA next destination address register HCH7			√			0000 _H	
FFFF7480 _H	DNDC7	DMA next destination chip select register CH7			√			0001 _H	
FFFF7482 _H	DTC7	DMA transfer count register CH7			√			0000 _H	
FFFF7484 _H	DNTC7	DMA next transfer count register CH7			√			0000 _H	
FFFF7486 _H	DTCC7	DMA transfer count compare register CH7			√			0000 _H	
FFFF7488 _H	DTCT7	DMA transfer control register CH7			√			0000 _H	
FFFF748A _H	DTS7	DMA transfer status register CH7	√	√				00 _H	

Caution If an unmapped address is accessed, a write access is ignored and 0 is returned in response to a read access.

5.4.3 Availability of Writing to Control Registers

Control registers can be classified into the two groups shown in the table below: those which are always writable and those for which writing is prohibited while DMA transfer is enabled. However, all of the registers are always readable.

Table 5-5 Availability of Writing to Control Registers

Availability of Writing	Register Name
Always writable	DTRC0, DNSAnL, DNSAnH, DNSCn, DNDAAnL, DNDAAnH, DNDCn, DNTCn, DTSn
Writing prohibited while DMA transfer is enabled (DTSnDTE = 1) Operation is not guaranteed if writing to these registers is attempted during while DMA transfer.	DTRS _n , DSAnL, DSAnH, DSCn, DDAAnL, DDAAnH, DDCn, DTCn, DTCCn, DTCTn

Note: n = 0 to 7

5.5 DMAC Control Registers

5.5.1 DTRC0: DMA Transfer Request Control Register 0

This eight-bit register includes an error flag and controls the suspension of DMA transfer that is currently in progress.

Access This register is readable/writable in 8- or 1-bit units.

Address FFFF 7300_H

Initial value 00_H

This register is initialized by a reset from any source.

7	6	5	4	3	2	1	0
DTRC0 ERR	0	0	0	0	0	0	DTRC0 ADS
R/W	R	R	R	R	R	R	R/W

Bit Position	Bit Name	Function
7	DTRC0ERR	DMA transfer error status This bit indicates that an error response has been received from a target for transfer during DMA transfer. To clear this bit, write 0 to it. 0: No DMA transfer error 1: DMA transfer error Note: If an error response is received, the DTRC0ERR and DTRC0ADS bits are set and a SysError exception is generated for the CPU.
0	DTRC0ADS	DMA transfer suspended This bit indicates that DMA transfer has been suspended by a transfer stop request. In addition, writing 1 to this bit suspends DMA transfer that is currently in progress. 0: DMA transfer is not suspended. 1: DMA transfer is suspended (reading) /DMA transfer suspension request (writing)

5.5.2 DTRSn (n = 0 to 7): DMA Transfer Request Select Register

This 16-bit register selects requests from the DMA transfer software and hardware.

Access This register is readable/writable in 16-bit units.

Address DTRS7: FFFF 7460_H, DTRS6: FFFF 7430_H, DTRS5: FFFF 7400_H,
DTRS4: FFFF 73D0_H, DTRS3: FFFF 73A0_H, DTRS2: FFFF 7370_H,
DTRS1: FFFF 7340_H, DTRS0: FFFF 7310_H

Initial value 0000_H

This register is initialized by a reset from any source.

15	14	13	12	11	10	9	8
0	0	0	0	0	0	0	0
R	R	R	R	R	R	R	R
7	6	5	4	3	2	1	0
0	0	0	0	DTRSn DTR3	DTRSn DTR2	DTRSn DTR1	DTRSn DTR0
R	R	R	R	R/W	R/W	R/W	R/W

Bit Position	Bit Name	Function																				
3 to 0	DTRSnDTR3 to DTRSnDTR0	DMA transfer request assignment These bits specify the assignment of a DMA transfer request to channel n.																				
		<table border="1"> <thead> <tr> <th>DTRSn DTR3</th><th>DTRSn DTR2</th><th>DTRSn DTR1</th><th>DTRSn DTR0</th><th>DAM Transfer Request</th></tr> </thead> <tbody> <tr> <td>0</td><td>0</td><td>0</td><td>0</td><td>Software DMA transfer request</td></tr> <tr> <td>0</td><td>0</td><td>0</td><td>1</td><td>Hardware DMA transfer request</td></tr> <tr> <td colspan="4">Other than the above</td><td>Setting prohibited</td></tr> </tbody> </table>	DTRSn DTR3	DTRSn DTR2	DTRSn DTR1	DTRSn DTR0	DAM Transfer Request	0	0	0	0	Software DMA transfer request	0	0	0	1	Hardware DMA transfer request	Other than the above				Setting prohibited
DTRSn DTR3	DTRSn DTR2	DTRSn DTR1	DTRSn DTR0	DAM Transfer Request																		
0	0	0	0	Software DMA transfer request																		
0	0	0	1	Hardware DMA transfer request																		
Other than the above				Setting prohibited																		

- Caution 1. Writing to these bits is prohibited while DMA transfer is enabled (DTRSnDTE bit = 1). Operation is not guaranteed if this is attempted.
- Caution 2. Operation is also not guaranteed if a prohibited setting is made in DTRSnDTR[3:0].

5.5.3 DSAnL (n = 0 to 7): DMA Source Address Register L

This 16-bit register forms the 16 lower-order bits of a 32-bit register used to set a source for transfer over the corresponding DMA channel.

Access This register is readable/writable in 16-bit units.

Address DSA7L: FFFF 7464_H, DSA6L: FFFF 7434_H, DSA5L: FFFF 7404_H,
DSA4L: FFFF 73D4_H, DSA3L: FFFF 73A4_H, DSA2L: FFFF 7374_H,
DSA1L: FFFF 7344_H, DSA0L: FFFF 7314_H

Initial value 0000_H

This register is initialized by a reset from any source.

15	14	13	12	11	10	9	8
DSAn SA15	DSAn SA14	DSAn SA13	DSAn SA12	DSAn SA11	DSAn SA10	DSAn SA9	DSAn SA8
R/W	R/W	R/W	R/W	R/W	R/W	R/W	R/W
7	6	5	4	3	2	1	0
DSAn SA7	DSAn SA6	DSAn SA5	DSAn SA4	DSAn SA3	DSAn SA2	DSAn SA1	DSAn SA0
R/W	R/W	R/W	R/W	R/W	R/W	R/W	R/W

Bit Position	Bit Name	Function
15 to 0	DSAnSA15 to DSAnSA0	DMA source address The 16 lower-order bits of the source address for transfer on channel n are set in these bits. If this register is read during DMA transfer, the value read is the corresponding part of the next address from which data is to be transferred. We recommend access to this register in combination with DSAnH as a 32-bit unit. If the DNSAnNSAV bit of the DNSAnH register is not set (to 1) on completion of DMA transfer, these bits revert to their previous values (those when DMA transfer was started).

- Caution 1. Writing to these bits is prohibited while DMA transfer is enabled (DTSnDTE bit = 1). Operation is not guaranteed if this is attempted.
- Caution 2. Set addresses by access in 32-bit units while the DTSnDTE bit is 0 because data transfer is not possible from an address for which setting is in progress.
- Caution 3. DMA transfer of misaligned data is not supported. The 4 lower-order bits of addresses corresponding to the transfer data size are as follows (x indicates any value).

Operation is not guaranteed if settings other than the following are made.

Data Size	DSAnSA3	DSAnSA2	DSAnSA1	DSAnSA0
8 bits	x	x	x	x
16 bits	x	x	x	0
32 bits	x	x	0	0
128 bits	0	0	0	0

5.5.4 DSA_nH (n = 0 to 7): DMA Source Address Register H

This 16-bit register forms the 16 higher-order bits of a 32-bit register used to set a source for transfer over the corresponding DMA channel.

Access This register is readable/writable in 16-bit units.

Address DSA7H: FFFF 7466_H, DSA6H: FFFF 7436_H, DSA5H: FFFF 7406_H,
DSA4H: FFFF 73D6_H, DSA3H: FFFF 73A6_H, DSA2H: FFFF 7376_H,
DSA1H: FFFF 7346_H, DSA0H: FFFF 7316_H

Initial value 0000_H

This register is initialized by a reset from any source.

15	14	13	12	11	10	9	8
0	0	0	DSA _n SA28	DSA _n SA27	DSA _n SA26	DSA _n SA25	DSA _n SA24
R	R	R	R/W	R/W	R/W	R/W	R/W
7	6	5	4	3	2	1	0
DSA _n SA23	DSA _n SA22	DSA _n SA21	DSA _n SA20	DSA _n SA19	DSA _n SA18	DSA _n SA17	DSA _n SA16
R/W	R/W	R/W	R/W	R/W	R/W	R/W	R/W

Bit Position	Bit Name	Function
12 to 0	DSA _n SA28 to DSA _n SA16	DMA source address The 13 higher-order bits of the source address for transfer on channel n are set in these bits. If this register is read during DMA transfer, the value read is the corresponding part of the next address from which data is to be transferred. We recommend access to this register in combination with DSA _n L as a 32-bit unit. If the DNSAnNSAV bit of the DNSAnH register is not set (to 1) on completion of DMA transfer, these bits revert to their previous values (those when DMA transfer was started).

- Caution 1. Writing to these bits is prohibited while DMA transfer is enabled (DTSnDTE bit = 1). Operation is not guaranteed if this is attempted.
- Caution 2. Set addresses by access in 32-bit units while the DTSnDTE bit is 0 because data transfer is not possible from an address for which setting is in progress.

5.5.5 DSCn (n = 0 to 7): DMA Source Chip Select Register

This 16-bit register selects the target chip-select area containing the transfer source.

Access This register is readable/writable in 16-bit units.

Address DSC7: FFFF 7468_H, DSC6: FFFF 7438_H, DSC5: FFFF 7408_H,
 DSC4: FFFF 73D8_H, DSC3: FFFF 73A8_H, DSC2: FFFF 7378_H,
 DSC1: FFFF 7348_H, DSC0: FFFF 7318_H

Initial value 0001_H

This register is initialized by a reset from any source.

15	14	13	12	11	10	9	8
0	0	0	0	0	0	0	0
R	R	R	R	R	R	R	R
7	6	5	4	3	2	1	0
0	0	0	0	0	DSCn SCS1	DSCn SCS0	DSCn SCSE
R	R	R	R	R	R/W	R/W	R/W

Bit Position	Bit Name	Function																
2 1 0	DSCnSCS1 DSCnSCS0 DSCnSCSE	DMA source chip select These bits specify an area to be selected as the source for transfer on channel n. <table border="1" style="margin-top: 10px;"> <thead> <tr> <th>DSCnS CS1</th> <th>DSCnS CS0</th> <th>DSCnS CSE</th> <th>Selected Area</th> </tr> </thead> <tbody> <tr> <td>0</td> <td>0</td> <td>1</td> <td>Data-flash, peripheral I/O area</td> </tr> <tr> <td>0</td> <td>1</td> <td>0</td> <td>Code-flash, on-chip RAM</td> </tr> <tr> <td colspan="3">Other than the above</td> <td>Setting prohibited</td> </tr> </tbody> </table>	DSCnS CS1	DSCnS CS0	DSCnS CSE	Selected Area	0	0	1	Data-flash, peripheral I/O area	0	1	0	Code-flash, on-chip RAM	Other than the above			Setting prohibited
DSCnS CS1	DSCnS CS0	DSCnS CSE	Selected Area															
0	0	1	Data-flash, peripheral I/O area															
0	1	0	Code-flash, on-chip RAM															
Other than the above			Setting prohibited															

- Caution 1. Writing to these bits is prohibited while DMA transfer is enabled (DTSnDTE bit = 1). Operation is not guaranteed if this is attempted.
- Caution 2. Set the DSCnSCS0 and DSCnSCSE bits so that only one of them is 1. Operation is not guaranteed if both bits are set to 1.
- Caution 3. Be sure to set the DSCnSCS1 bit to 0.

5.5.6 DNSAnL (n = 0 to 7): DMA Next Source Address Register L

This 16-bit register forms the 16 lower-order bits of a 32-bit register used to set the next source for transfer over the corresponding DMA channel.

Access This register is readable/writable in 16-bit units.

Address DNSA7L: FFFF 746C_H, DNSA6L: FFFF 743C_H, DNSA5L: FFFF 740C_H,
DNSA4L: FFFF 73DC_H, DNSA3L: FFFF 73AC_H, DNSA2L: FFFF 737C_H,
DNSA1L: FFFF 734C_H, DNSA0L: FFFF 731C_H

Initial value 0000_H

This register is initialized by a reset from any source.

15	14	13	12	11	10	9	8
DNSAn NSA15	DNSAn NSA14	DNSAn NSA13	DNSAn NSA12	DNSAn NSA11	DNSAn NSA10	DNSAn NSA9	DNSAn NSA8
R/W	R/W	R/W	R/W	R/W	R/W	R/W	R/W
7	6	5	4	3	2	1	0
DNSAn NSA7	DNSAn NSA6	DNSAn NSA5	DNSAn NSA4	DNSAn NSA3	DNSAn NSA2	DNSAn NSA1	DNSAn NSA0
R/W	R/W	R/W	R/W	R/W	R/W	R/W	R/W

Bit Position	Bit Name	Function
15 to 0	DNSAnNSA15 to DNSAnNSA0	DMA next source address The 16 lower-order bits of the source address for the next transfer on channel n are set in these bits.

Caution DMA transfer of misaligned data is not supported. The 4 lower-order bits of addresses corresponding to the transfer data size are as follows (x indicates any value).

Operation is not guaranteed if settings other than the following are made.

Data Size	DNSAnNSA3	DNSAnNSA2	DNSAnNSA1	DNSAnNSA0
8 bits	x	x	x	x
16 bits	x	x	x	0
32 bits	x	x	0	0
128 bits	0	0	0	0

5.5.7 DNSAnH (n = 0 to 7): DMA Next Source Address Register H

This 16-bit register forms the 16 higher-order bits of a 32-bit register used to set the next source for transfer over the corresponding DMA channel.

Access This register is readable/writable in 16-bit units.

Address DNSA7H: FFFF 746E_H, DNSA6H: FFFF 743E_H, DNSA5H: FFFF 740E_H,
DNSA4H: FFFF 73DE_H, DNSA3H: FFFF 73AE_H, DNSA2H: FFFF 737E_H,
DNSA1H: FFFF 734E_H, DNSA0H: FFFF 731E_H

Initial value 0000_H

This register is initialized by a reset from any source.

15	14	13	12	11	10	9	8
DNSAnNSAV	0	0	DNSAnNSA28	DNSAnNSA27	DNSAnNSA26	DNSAnNSA25	DNSAnNSA24
R/W	R	R	R/W	R/W	R/W	R/W	R/W
7	6	5	4	3	2	1	0
DNSAnNSA23	DNSAnNSA22	DNSAnNSA21	DNSAnNSA20	DNSAnNSA19	DNSAnNSA18	DNSAnNSA17	DNSAnNSA16
R/W	R/W	R/W	R/W	R/W	R/W	R/W	R/W

Bit Position	Bit Name	Function
15	DNSAnNSAV	DMA next source address valid This bit controls whether to copy the address from the DMA next source address register to the DMA source address register on completion of DMA transfer. It is cleared once the address has been copied. 0: Does not copy/copying completed 1: Copies/copying not completed
12 to 0	DNSAnNSA28 to DNSAnNSA16	DMA next source address These bits specify the 13 higher-order bits of the source address for the next transfer on channel n.

5.5.8 DNSCn (n = 0 to 7): DMA Next Source Chip Select Register

This 16-bit register selects the target area containing the source for the next transfer.

Access This register is readable/writable in 16-bit units.

Address DNSC7: FFFF 7470_H, DNSC6: FFFF 7440_H, DNSC5: FFFF 7410_H,
DNSC4: FFFF 73E0_H, DNSC3: FFFF 73B0_H, DNSC2: FFFF 7380_H,
DNSC1: FFFF 7350_H, DNSC0: FFFF 7320_H

Initial value 0001H

This register is initialized by a reset from any source.

15	14	13	12	11	10	9	8
DNSCn NSCV	0	0	0	0	0	0	0
R/W	R	R	R	R	R	R	R
7	6	5	4	3	2	1	0
0	0	0	0	0	DNSCn NSCS1	DNSCn NSCS0	DNSCn NSCSE
R	R	R	R	R	R/W	R/W	R/W

Bit Position	Bit Name	Function																
15	DNSCnNSCV	DMA next source address select valid This bit controls whether to copy the chip select signal from the DMA next source chip select register to the DMA source chip select register on completion of DMA. It is cleared once the chip select signal has been copied. 0: Does not copy/copying completed 1: Copies/copying not completed																
2 1 0	DNSCnNSCS1 DNSCnNSCS0 DNSCnNSCSE	DMA next source chip select These bits specify the area to be selected as the transfer source for the next transfer on channel n. <table border="1" data-bbox="582 1384 1382 1585"> <thead> <tr> <th>DNSCn NSCS1</th><th>DNSCn NSCS0</th><th>DNSCn NSCSE</th><th>Selected Area</th></tr> </thead> <tbody> <tr> <td>0</td><td>0</td><td>1</td><td>Data-flash, peripheral I/O area</td></tr> <tr> <td>0</td><td>1</td><td>0</td><td>Code-flash, on-chip RAM</td></tr> <tr> <td colspan="3">Other than the above</td><td>Setting prohibited</td></tr> </tbody> </table>	DNSCn NSCS1	DNSCn NSCS0	DNSCn NSCSE	Selected Area	0	0	1	Data-flash, peripheral I/O area	0	1	0	Code-flash, on-chip RAM	Other than the above			Setting prohibited
DNSCn NSCS1	DNSCn NSCS0	DNSCn NSCSE	Selected Area															
0	0	1	Data-flash, peripheral I/O area															
0	1	0	Code-flash, on-chip RAM															
Other than the above			Setting prohibited															

Caution 1. Set the DNSCnNSCS0 and DNSCnNSCSE bits so that only one of them is 1. Operation is not guaranteed if both bits are set to 1.

Caution 2. Be sure to set the DNSCnNSCS1 bit to 0.

5.5.9 DDAnL (n = 0 to 7): DMA Destination Address Register L

This 16-bit register forms the 16 lower-order bits of a 32-bit register used to set a destination for transfer over a DMA channel.

Access This register is readable/writable in 16-bit units.

Address DDA7L: FFFF 7474_H, DDA6L: FFFF 7444_H, DDA5L: FFFF 7414_H,
DDA4L: FFFF 73E4_H, DDA3L: FFFF 73B4_H, DDA2L: FFFF 7384_H,
DDA1L: FFFF 7354_H, DDA0L: FFFF 7324_H

Initial value 0000_H

This register is initialized by a reset from any source.

15	14	13	12	11	10	9	8
DDAn DA15	DDAn DA14	DDAn DA13	DDAn DA12	DDAn DA11	DDAn DA10	DDAn DA9	DDAn DA8
R/W	R/W	R/W	R/W	R/W	R/W	R/W	R/W
7	6	5	4	3	2	1	0
DDAn DA7	DDAn DA6	DDAn DA5	DDAn DA4	DDAn DA3	DDAn DA2	DDAn DA1	DDAn DA0
R/W	R/W	R/W	R/W	R/W	R/W	R/W	R/W

Bit Position	Bit Name	Function
15 to 0	DDAnDA15 to DDAnDA0	DMA destination address The 16 lower-order bits of the destination address for transfer on channel n are set in these bits. If this register is read during DMA transfer, the value read is the corresponding part of the next address from which data is to be transferred. We recommend access to this register in combination with DDAnH as a 32-bit unit. If the DNDAnNDV bit in the DNDAnH register is not set (to 1) on completion of DMA transfer, these bits revert to their previous values (those when DMA transfer was started).

- Caution 1. Writing to these bits is prohibited while DMA transfer is enabled (DTSnDTE bit = 1). Operation is not guaranteed if this is attempted.
- Caution 2. Set addresses by access in 32-bit units while the DTSnDTE bit is 0 because data transfer is not possible from an address for which setting is in progress.
- Caution 3. If an error occurs in the target for transfer in a cycle of reading for DMA transfer, the corresponding write cycle is not executed but the destination address is still updated.
- Caution 4. DMA transfer of misaligned data is not supported. The 4 lower-order bits of addresses corresponding to the transfer data size are as follows (x indicates any value).

Operation is not guaranteed if settings other than the following are made.

Data Size	DDAnDA3	DDAnDA2	DDAnDA1	DDAnDA0
8 bits	x	x	x	x
16 bits	x	x	x	0
32 bits	x	x	0	0
128 bits	0	0	0	0

5.5.10 DDAnH (n = 0 to 7): DMA Destination Address Register H

This 16-bit register forms the 16 higher-order bits of a 32-bit register used to set a destination for transfer over the corresponding DMA channel.

Access This register is readable/writable in 16-bit units.

Address DDA7H: FFFF 7476_H, DDA6H: FFFF 7446_H, DDA5H: FFFF 7416_H,
DDA4H: FFFF 73E6_H, DDA3H: FFFF 73B6_H, DDA2H: FFFF 7386_H,
DDA1H: FFFF 7356_H, DDA0H: FFFF 7326_H

Initial value 0000_H

This register is initialized by a reset from any source.

15	14	13	12	11	10	9	8
0	0	0	DDAn DA28	DDAn DA27	DDAn DA26	DDAn DA25	DDAn DA24
R	R	R	R/W	R/W	R/W	R/W	R/W
7	6	5	4	3	2	1	0
DDAn DA23	DDAn DA22	DDAn DA21	DDAn DA20	DDAn DA19	DDAn DA18	DDAn DA17	DDAn DA16
R/W	R/W	R/W	R/W	R/W	R/W	R/W	R/W

Bit Position	Bit Name	Function
12 to 0	DDAnDA28 to DDAnDA16	DMA destination address The 13 higher-order bits of the destination address for transfer on channel n are set in these bits. If this register is read during DMA transfer, the value read is the corresponding part of the next address from which data is to be transferred. We recommend access to this register in combination with DDAnL as a 32-bit unit. If the DNDAnNDAV bit in the DNDAnH register is not set (to 1) on completion of DMA transfer, these bits revert to their previous values (those when DMA transfer was started).

- Caution 1. Writing to these bits is prohibited while DMA transfer is enabled (DTSnDTE bit = 1). Operation is not guaranteed if this is attempted.
- Caution 2. Set addresses by access in 32-bit units while the DTSnDTE bit is 0 because data transfer is not possible from an address for which setting is in progress.
- Caution 3. If an error occurs in the target for transfer in a cycle of reading for DMA transfer, the corresponding write cycle is not executed but the destination address is still updated.

5.5.11 DDCn (n = 0 to 7): DMA Destination Chip Select Register

This 16-bit register selects the target area containing the transfer destination.

Access This register is readable/writable in 16-bit units.

Address DDC7: FFFF 7478_H, DDC6: FFFF 7448_H, DDC5: FFFF 7418_H,
 DDC4: FFFF 73E8_H, DDC3: FFFF73B8_H, DDC2: FFFF 7388_H,
 DDC1: FFFF 7358_H, DDC0: FFFF 7328_H

Initial value 0001_H

This register is initialized by a reset from any source.

15	14	13	12	11	10	9	8
0	0	0	0	0	0	0	0
R	R	R	R	R	R	R	R
7	6	5	4	3	2	1	0
0	0	0	0	0	DDCn DCS1	DDCn DCS0	DDCn DCSE
R	R	R	R	R	R/W	R/W	R/W

Bit Position	Bit Name	Function																
2 1 0	DDCnDCS1 DDCnDCS0 DDCnDCSE	DMA destination chip select These bits specify an area to be selected as the transfer destination of channel n.																
		<table border="1"> <thead> <tr> <th>DDCnD CS1</th> <th>DDCnD CS0</th> <th>DDCnD CSE</th> <th>Selected Area</th> </tr> </thead> <tbody> <tr> <td>0</td> <td>0</td> <td>1</td> <td>Data-flash, peripheral I/O area</td> </tr> <tr> <td>0</td> <td>1</td> <td>0</td> <td>Code-flash, on-chip RAM</td> </tr> <tr> <td colspan="3">Other than the above</td> <td>Setting prohibited</td> </tr> </tbody> </table>	DDCnD CS1	DDCnD CS0	DDCnD CSE	Selected Area	0	0	1	Data-flash, peripheral I/O area	0	1	0	Code-flash, on-chip RAM	Other than the above			Setting prohibited
DDCnD CS1	DDCnD CS0	DDCnD CSE	Selected Area															
0	0	1	Data-flash, peripheral I/O area															
0	1	0	Code-flash, on-chip RAM															
Other than the above			Setting prohibited															

- Caution 1. Writing to these bits is prohibited while DMA transfer is enabled (DTSnDTE bit = 1). Operation is not guaranteed if this is attempted.
- Caution 2. Set the DDCnDCS0 and DDCnDCSE bits so that only one of them is 1. Operation is not guaranteed if both bits are set to 1.
- Caution 3. Be sure to set the DDCnDCS1 bit to 0.

5.5.12 DNDA_nL (n = 0 to 7): DMA Next Destination Address Register L

This 16-bit register forms the 16 lower-order bits of a 32-bit register used to set the next destination for transfer over the corresponding DMA channel.

Access This register is readable/writable in 16-bit units.

Address DNDA7L: FFFF 747C_H, DNDA6L: FFFF 744C_H, DNDA5L: FFFF 741C_H, DNDA4L: FFFF 73EC_H, DNDA3L: FFFF 73BC_H, DNDA2L: FFFF 738C_H, DNDA1L: FFFF 735C_H, DNDA0L: FFFF 732C_H

Initial value 0000_H

This register is initialized by a reset from any source.

15	14	13	12	11	10	9	8
DNDA _n NDA15	DNDA _n NDA14	DNDA _n NDA13	DNDA _n NDA12	DNDA _n NDA11	DNDA _n NDA10	DNDA _n NDA9	DNDA _n NDA8
R/W	R/W	R/W	R/W	R/W	R/W	R/W	R/W
7	6	5	4	3	2	1	0
DNDA _n NDA7	DNDA _n NDA6	DNDA _n NDA5	DNDA _n NDA4	DNDA _n NDA3	DNDA _n NDA2	DNDA _n NDA1	DNDA _n NDA0
R/W	R/W	R/W	R/W	R/W	R/W	R/W	R/W

Bit Position	Bit Name	Function
15 to 0	DNDA _n NDA15 to DNDA _n NDA0	DMA next destination address These bits specify the 16 lower-order bits of the destination address for the next transfer on channel n.

Caution DMA transfer of misaligned data is not supported. The four lower-order bits of addresses corresponding to the transfer data size are as follows (x indicates any value).

Operation is not guaranteed if settings other than the following are made.

Data Size	DNDA _n NDA3	DNDA _n NDA2	DNDA _n NDA1	DNDA _n NDA0
8 bits	x	x	x	x
16 bits	x	x	x	0
32 bits	x	x	0	0
128 bits	0	0	0	0

5.5.13 DNDAnH (n = 0 to 7): DMA Next Destination Address Register H

This 16-bit register forms the 16 higher-order bits of a 32-bit register used to set the next destination for transfer over the corresponding DMA channel.

Access This register is readable/writable in 16-bit units.

Address DNDA7H: FFFF 747E_H, DNDA6H: FFFF 744E_H, DNDA5H: FFFF 741E_H,
DNDA4H: FFFF 73EE_H, DNDA3H: FFFF 73BE_H, DNDA2H: FFFF 738E_H,
DNDA1H: FFFF 735E_H, DNDA0H: FFFF 732E_H

Initial value 0000_H

This register is initialized by a reset from any source.

15	14	13	12	11	10	9	8
DNDAn NDAV	0	0	DNDAn NDA28	DNDAn NDA27	DNDAn NDA26	DNDAn NDA25	DNDAn NDA24
R/W	R	R	R/W	R/W	R/W	R/W	R/W
7	6	5	4	3	2	1	0
DNDAn NDA23	DNDAn NDA22	DNDAn NDA21	DNDAn NDA20	DNDAn NDA19	DNDAn NDA18	DNDAn NDA17	DNDAn NDA16
R/W	R/W	R/W	R/W	R/W	R/W	R/W	R/W

Bit Position	Bit Name	Function
15	DNDAnNDAV	DMA next destination address valid This bit controls whether to copy the address from the DMA next destination address register to the DMA destination address register on completion of DMA transfer. It is cleared once the address has been copied. 0: Does not copy/copying completed 1: Copies/copying not completed
12 to 0	DNDAnNDA28 to DNDAnNDA16	DMA next destination address These bits specify the 13 higher-order bits of the destination address for the next transfer on channel n.

5.5.14 DNDCn (n = 0 to 7): DMA Next Destination Chip Select Register

This 16-bit register selects the target area containing the next destination for transfer.

Access This register is readable/writable in 16-bit units.

Address DNDC7: FFFF 7480_H, DNDC6: FFFF 7450_H, DNDC5: FFFF 7420_H,
DNDC4: FFFF 73F0_H, DNDC3: FFFF 73C0_H, DNDC2: FFFF 7390_H,
DNDC1: FFFF 7360_H, DNDC0: FFFF 7330_H

Initial value 0001_H

This register is initialized by a reset from any source.

15	14	13	12	11	10	9	8
DNDCn NDCV	0	0	0	0	0	0	0
R/W	R	R	R	R	R	R	R
7	6	5	4	3	2	1	0
0	0	0	0	0	DNDCn NDCS1	DNDCn NDCS0	DNDCn NDCSE
R	R	R	R	R	R/W	R/W	R/W

Bit Position	Bit Name	Function																
15	DNDCnNDCV	DMA next destination chip select valid This bit controls whether to copy the chip select signal from the DMA next destination chip select register to the DMA destination chip select register on completion of DMA. It is cleared once the chip select signal has been copied. 0: Does not copy/copying completed 1: Copies/copying not completed																
2 1 0	DNDCnNDCS1 DNDCnNDCS0 DNDCnNDCSE	DMA next destination chip select These bits specify the area to be selected as the transfer destination for the next transfer on channel n. <table border="1" data-bbox="582 1429 1382 1630"> <thead> <tr> <th>DNDCn NDCS1</th><th>DNDCn NDCS0</th><th>DNDCn NDCSE</th><th>Selected Area</th></tr> </thead> <tbody> <tr> <td>0</td><td>0</td><td>1</td><td>Data-flash, peripheral I/O area</td></tr> <tr> <td>0</td><td>1</td><td>0</td><td>Code-flash, on-chip RAM</td></tr> <tr> <td colspan="3">Other than above</td><td>Setting prohibited</td></tr> </tbody> </table>	DNDCn NDCS1	DNDCn NDCS0	DNDCn NDCSE	Selected Area	0	0	1	Data-flash, peripheral I/O area	0	1	0	Code-flash, on-chip RAM	Other than above			Setting prohibited
DNDCn NDCS1	DNDCn NDCS0	DNDCn NDCSE	Selected Area															
0	0	1	Data-flash, peripheral I/O area															
0	1	0	Code-flash, on-chip RAM															
Other than above			Setting prohibited															

- Caution 1. Set the DNDCnNDCS0 and DNDCnNDCSE bits so that only one of them is 1. Operation is not guaranteed if both bits are set to 1.
- Caution 2. Be sure to set the DNDCnNDCS1 bit to 0.

5.5.15 DTCn (n = 0 to 7): DMA Transfer Count Register

This 16-bit register sets the number of times unit transfer on the DMA channel is to proceed.

Access This register is readable/writable in 16-bit units.

Address DTC7: FFFF 7482_H, DTC6: FFFF 7452_H, DTC5: FFFF 7422_H,
DTC4: FFFF 73F2_H, DTC3: FFFF 73C2_H, DTC2: FFFF 7392_H,
DTC1: FFFF 7362_H, DTC0: FFFF 7332_H

Initial value 0000_H

This register is initialized by a reset from any source.

15	14	13	12	11	10	9	8
0	DTCnDTC14	DTCnDTC13	DTCnDTC12	DTCnDTC11	DTCnDTC10	DTCnDTC9	DTCnDTC8
R	R/W	R/W	R/W	R/W	R/W	R/W	R/W
7	6	5	4	3	2	1	0
DTCnDTC7	DTCnDTC6	DTCnDTC5	DTCnDTC4	DTCnDTC3	DTCnDTC2	DTCnDTC1	DTCnDTC0
R/W	R/W	R/W	R/W	R/W	R/W	R/W	R/W

Bit Position	Bit Name	Function										
14 to 0	DTCnDTC14 to DTCnDTC0	<p>DMA transfer count</p> <p>These bits specify the number of times DMA transfer (DMA transfer count) is to proceed on channel n. Reading this register during DMA transfer returns the remaining number of times DMA transfer is to be executed. If the DNTCnNTCV bit of the DNTCn register is not set (to 1), these bits hold the value when DMA transfer has been completed (0000_H).</p> <p>If DMA transfer is completed with the DTCTn.DTCTnMLE = 1, next transfer is executed 32, 768 times upon a DMA transfer request.</p> <table border="1" data-bbox="584 1283 1385 1585"> <thead> <tr> <th>DTCnDTC[14:0]</th><th>Operation</th></tr> </thead> <tbody> <tr> <td>0000_H</td><td>Transfer executed 32, 768 times or until completion of transfer</td></tr> <tr> <td>0001_H</td><td>Transfer executed once or transfer to be executed once</td></tr> <tr> <td>:</td><td>:</td></tr> <tr> <td>7FFF_H</td><td>Transfer executed 32, 767 times or 32, 767 times of transfer to be executed</td></tr> </tbody> </table>	DTCnDTC[14:0]	Operation	0000 _H	Transfer executed 32, 768 times or until completion of transfer	0001 _H	Transfer executed once or transfer to be executed once	:	:	7FFF _H	Transfer executed 32, 767 times or 32, 767 times of transfer to be executed
DTCnDTC[14:0]	Operation											
0000 _H	Transfer executed 32, 768 times or until completion of transfer											
0001 _H	Transfer executed once or transfer to be executed once											
:	:											
7FFF _H	Transfer executed 32, 767 times or 32, 767 times of transfer to be executed											

Caution 1. Writing to these bits is prohibited while DMA transfer is enabled (DTSnDTE bit = 1). Operation is not guaranteed if this is attempted.

Caution 2. If an error occurs in the target for transfer in a cycle of reading for DMA transfer, the corresponding write cycle is not executed but the destination address is still updated.

5.5.16 DNTCn (n = 0 to 7): DMA Next Transfer Count Register

This 16-bit register sets the number of times transfer on the DMA channel is to proceed.

Access This register is readable/writable in 16-bit units.

Address DNTC7: FFFF 7484_H, DNTC6: FFFF 7454_H, DNTC5: FFFF 7424_H,
DNTC4: FFFF 73F4_H, DNTC3: FFFF 73C4_H, DNTC2: FFFF 7394_H,
DNTC1: FFFF 7364_H, DNTC0: FFFF 7334_H

Initial value 0000_H

This register is initialized by a reset from any source.

15	14	13	12	11	10	9	8
DNTCn NTCV	DNTCn NDTC14	DNTCn NDTC13	DNTCn NDTC12	DNTCn NDTC11	DNTCn NDTC10	DNTCn NDTC9	DNTCn NDTC8
R/W	R/W	R/W	R/W	R/W	R/W	R/W	R/W
7	6	5	4	3	2	1	0
DNTCn NDTC7	DNTCn NDTC6	DNTCn NDTC5	DNTCn NDTC4	DNTCn NDTC3	DNTCn NDTC2	DNTCn NDTC1	DNTCn NDTC0
R/W	R/W	R/W	R/W	R/W	R/W	R/W	R/W

Bit Position	Bit Name	Function										
15	DNTCnNTCV	DMA next transfer count valid This bit controls whether or not copying of the number of DMA unit transfers (DMA transfer count) from the DMA next transfer count register to the DMA count register is to proceed on completion of DMA transfer. It is cleared once the DMA transfer count has been copied. 0: Does not copy/copying completed 1: Copies/copying not completed										
14 to 0	DNTCnNDTC14 to DNTCnNDTC0	DMA next transfer count These bits specify the number of times unit DMA transfer is to proceed on channel n. <table border="1" data-bbox="582 1377 1380 1590"> <thead> <tr> <th>DNTCnNDTC[14:0]</th><th>Operation</th></tr> </thead> <tbody> <tr> <td>0000_H</td><td>Transfer executed 32, 768 times</td></tr> <tr> <td>0001_H</td><td>Transfer executed once</td></tr> <tr> <td>:</td><td>:</td></tr> <tr> <td>7FFF_H</td><td>Transfer executed 32, 767 times</td></tr> </tbody> </table>	DNTCnNDTC[14:0]	Operation	0000 _H	Transfer executed 32, 768 times	0001 _H	Transfer executed once	:	:	7FFF _H	Transfer executed 32, 767 times
DNTCnNDTC[14:0]	Operation											
0000 _H	Transfer executed 32, 768 times											
0001 _H	Transfer executed once											
:	:											
7FFF _H	Transfer executed 32, 767 times											

5.5.17 DTCCn (n =0 to 7): DMA Transfer Count Compare Register

The value in this 16-bit register is compared with that in the DMA transfer counter and interrupts are controlled accordingly.

Access This register is readable/writable in 16-bit units.

Address DTCC7: FFFF 7486_H, DTCC6: FFFF 7456_H, DTCC5: FFFF 7426_H,
DTCC4: FFFF 73F6_H, DTCC3: FFFF 73C6_H, DTCC2: FFFF 7396_H,
DTCC1: FFFF 7366_H, DTCC0: FFFF 7336_H

Initial value 0000_H

This register is initialized by a reset from any source.

15	14	13	12	11	10	9	8
0	DTCCn DTCC14	DTCCn DTCC13	DTCCn DTCC12	DTCCn DTCC11	DTCCn DTCC10	DTCCn DTCC9	DTCCn DTCC8
R	R/W	R/W	R/W	R/W	R/W	R/W	R/W
7	6	5	4	3	2	1	0
DTCCn DTCC7	DTCCn DTCC6	DTCCn DTCC5	DTCCn DTCC4	DTCCn DTCC3	DTCCn DTCC2	DTCCn DTCC1	DTCCn DTCC0
R/W	R/W	R/W	R/W	R/W	R/W	R/W	R/W

Bit Position	Bit Name	Function										
14 to 0	DTCCnDTCC14 to DTCCnDTCC0	<p>DMA transfer count comparison DTCC[14:0] specifies a number of times transfer is to proceed for comparison with the value in the DMA transfer count register for channel n, and an interrupt is generated when the two (DTCn and DTCCn) match. DTCCn can be used as a trigger for setting of the next address. More precisely, an interrupt is generated when unit DMA transfer has been completed the same number of times as the value in the DTCCn register.</p> <table border="1"> <thead> <tr> <th>DTCCnDTCC[14:0]</th><th>Operation</th></tr> </thead> <tbody> <tr> <td>0000_H</td><td>Not compared</td></tr> <tr> <td>0001_H</td><td>Interrupt is generated when DTC = 0001_H</td></tr> <tr> <td>:</td><td>:</td></tr> <tr> <td>7FFF_H</td><td>Interrupt is generated when DTC = 7FFF_H</td></tr> </tbody> </table>	DTCCnDTCC[14:0]	Operation	0000 _H	Not compared	0001 _H	Interrupt is generated when DTC = 0001 _H	:	:	7FFF _H	Interrupt is generated when DTC = 7FFF _H
DTCCnDTCC[14:0]	Operation											
0000 _H	Not compared											
0001 _H	Interrupt is generated when DTC = 0001 _H											
:	:											
7FFF _H	Interrupt is generated when DTC = 7FFF _H											

Caution Writing to these bits is prohibited while DMA transfer is enabled (DTSnDTE bit = 1). Operation is not guaranteed if this is attempted.

5.5.18 DTCTn (n = 0 to 7): DMA Transfer Control Register

This 16-bit register sets transfer data size and direction (up or down) for counting of addresses.

Access This register is readable/writable in 16-bit units.

Address DTCT7: FFFF 7488_H, DTCT6: FFFF 7458_H, DTCT5: FFFF 7428_H,
DTCT4: FFFF 73F8_H, DTCT3: FFFF 73C8_H, DTCT2: FFFF 7398_H,
DTCT1: FFFF 7368_H, DTCT0: FFFF 7338_H

Initial value 0000_H

This register is initialized by a reset from any source.

15	14	13	12	11	10	9	8
0	DTCTnDS1	DTCTnDS0	DTCTnMLE	0	0	0	0
R	R/W	R/W	R/W	R	R	R	R
7	6	5	4	3	2	1	0
DTCTnSACM1	DTCTnSACM0	DTCTnDACM1	DTCTnDACM0	0	0	0	0
R/W	R/W	R/W	R/W	R	R	R	R

Bit Position	Bit Name	Function															
14 13	DTCTnDS1 DTCTnDS0	DMA transfer data size These bits specify the DMA transfer data size of channel n. <table border="1" data-bbox="582 1142 1385 1355"> <thead> <tr> <th>DTCTnDS1</th><th>DTCTnDS0</th><th>Transfer Data Size</th></tr> </thead> <tbody> <tr> <td>0</td><td>0</td><td>8 bits</td></tr> <tr> <td>0</td><td>1</td><td>16 bits</td></tr> <tr> <td>1</td><td>0</td><td>32 bits</td></tr> <tr> <td>1</td><td>1</td><td>128 bits</td></tr> </tbody> </table>	DTCTnDS1	DTCTnDS0	Transfer Data Size	0	0	8 bits	0	1	16 bits	1	0	32 bits	1	1	128 bits
DTCTnDS1	DTCTnDS0	Transfer Data Size															
0	0	8 bits															
0	1	16 bits															
1	0	32 bits															
1	1	128 bits															
12	DTCTnMLE	Multi-link enable This bit specifies whether to acknowledge the next DMA transfer request without clearing the DTSnTC bit (to 0) after DMA transfer has been completed. If this bit is set (to 1), the DTSnDTE bit is not cleared upon completion of DMA transfer. Even if the DTSnTC bit is not cleared, DMA transfer is executed if a DMA transfer request is issued. 0: The DTSnDTE bit is cleared upon completion of DMA transfer. 1: The DTSnDTE bit is not cleared upon completion of DMA transfer.															

Bit Position	Bit Name	Function															
7 6	DTCTnSACM1 DTCTnSACM0	<p>DMA transfer source address counting direction These bits specify the direction (up or down) in which counting from the transfer source address for channel n is to proceed.</p> <table border="1"> <thead> <tr> <th>DTCTnSACM1</th> <th>DTCTnSACM0</th> <th>Counting Direction</th> </tr> </thead> <tbody> <tr> <td>0</td> <td>0</td> <td>Incremented</td> </tr> <tr> <td>0</td> <td>1</td> <td>Decrement</td> </tr> <tr> <td>1</td> <td>0</td> <td>Fixed</td> </tr> <tr> <td>1</td> <td>1</td> <td>Setting prohibited</td> </tr> </tbody> </table>	DTCTnSACM1	DTCTnSACM0	Counting Direction	0	0	Incremented	0	1	Decrement	1	0	Fixed	1	1	Setting prohibited
DTCTnSACM1	DTCTnSACM0	Counting Direction															
0	0	Incremented															
0	1	Decrement															
1	0	Fixed															
1	1	Setting prohibited															
5 4	DTCTnDACM1 DTCTnDACM0	<p>DMA transfer destination address counting direction These bits specify the direction (up or down) in which counting from the transfer destination address for channel n is to proceed.</p> <table border="1"> <thead> <tr> <th>DTCTnDACM1</th> <th>DTCTnDACM0</th> <th>Counting Direction</th> </tr> </thead> <tbody> <tr> <td>0</td> <td>0</td> <td>Incremented</td> </tr> <tr> <td>0</td> <td>1</td> <td>Decrement</td> </tr> <tr> <td>1</td> <td>0</td> <td>Fixed</td> </tr> <tr> <td>1</td> <td>1</td> <td>Setting prohibited</td> </tr> </tbody> </table>	DTCTnDACM1	DTCTnDACM0	Counting Direction	0	0	Incremented	0	1	Decrement	1	0	Fixed	1	1	Setting prohibited
DTCTnDACM1	DTCTnDACM0	Counting Direction															
0	0	Incremented															
0	1	Decrement															
1	0	Fixed															
1	1	Setting prohibited															

- Caution 1. Writing to these bits is prohibited while DMA transfer is enabled (DTSnDTE bit = 1). Operation is not guaranteed if this is attempted.
- Caution 2. Operation is not guaranteed if the DTCTnSACM[1:0] and DTCTnDACM[1:0] bits are set to a prohibited state.
- Caution 3. Be sure to set bits 11 and 0 of the DTCTn register to 0.

5.5.19 DTSn (n = 0 to 7): DMA Transfer Status Register

This 8-bit register is for checking the state of DMA transfer control.

- Access** This register is readable and writable in 1- and 8-bit units.
- Address** DTS7: FFFF 748A_H, DTS6: FFFF 745A_H, DTS5: FFFF 742A_H,
DTS4: FFFF 73FA_H, DTS3: FFFF 73CA_H, DTS2: FFFF 739A_H,
DTS1: FFFF 736A_H, DTS0: FFFF 733A_H

Initial value 00_H

This register is initialized by a reset from any source.

7	6	5	4	3	2	1	0
DTSnTC	DTSnDT	0	0	DTSnER	DTSnDR	DTSnSR	DTSnDTE
R/W	R/W	R	R	R	R	R/W	R/W

Bit Position	Bit Name	Function
7	DTSnTC	DMA transfer end status This bit indicates that DMA transfer has been completed. To clear this bit, write 0 to it after reading it as 1. We recommend using bit-manipulation instructions such as CLR1 when writing to this bit. 0: DMA transfer not completed 1: DMA transfer completed
6	DTSnDT	DMA transfer status This bit indicates that a DMA transfer request has been acknowledged and that DMA transfer is in progress. It is not set (to 1) when a DMA transfer request is simply issued. This bit is cleared (to 0) on completion of DMA transfer. If the DTSnDTE bit is 0, this bit can be cleared by the user (and writing to this bit can proceed at the same time as writing to the DTSnDTE bit). 0: DMA transfer request acknowledged 1: DMA transfer in progress
3	DTSnER	DMA transfer error flag This bit indicates that a DMA transfer error has occurred in channel n. It is cleared (to 0) when the DTRC0ERR bit of the DTRC0 register is cleared. Note that this bit is read-only. 0: No DMA transfer error 1: DMA transfer error
2	DTSnDR	Hardware DMA transfer request flag This bit indicates the presence or absence of a hardware DMA transfer request for channel n. The bit is cleared (to 0) when the hardware DMA transfer request is negated. The state of the DTSnDTE bit does not affect the operation of this bit. It is not set (to 1) by a software DMA transfer request, or by a hardware DMA transfer request when a software DMA transfer request is currently selected in the DMA transfer request selection register. Note that this bit is read-only. 0: No hardware DMA transfer request 1: Hardware DMA transfer request
1	DTSnSR	Software DMA transfer request This bit selects a software DMA transfer request. If the software DMA transfer request is currently selected in the DMA transfer request select register, writing 1 to this bit and to the DTSnDTE bit starts DMA transfer. This bit is automatically cleared (to 0) when DMA transfer has been completed. Writing 0 to this bit suspends DMA transfer. 0: No software DMA transfer request 1: Software DMA transfer request

Bit Position	Bit Name	Function
0	DTSnDTE	<p>DMA transfer enable</p> <p>This bit enables or disables DMA transfer. After a 1 is written to this bit, DMA transfer is executed once a DMA transfer request is issued. This bit is automatically cleared (to 0) on completion of DMA transfer if the DTCTnMLE bit is 0.</p> <p>DMA transfer is suspended if 0 is written to this bit during DMA transfer.</p> <p>0: DMA transfer is disabled. 1: DMA transfer is enabled.</p>

5.6 DMAC Function Details

5.6.1 DMAC Transfer Setting Flow

The following figure shows the flow of DMAC transfer settings.

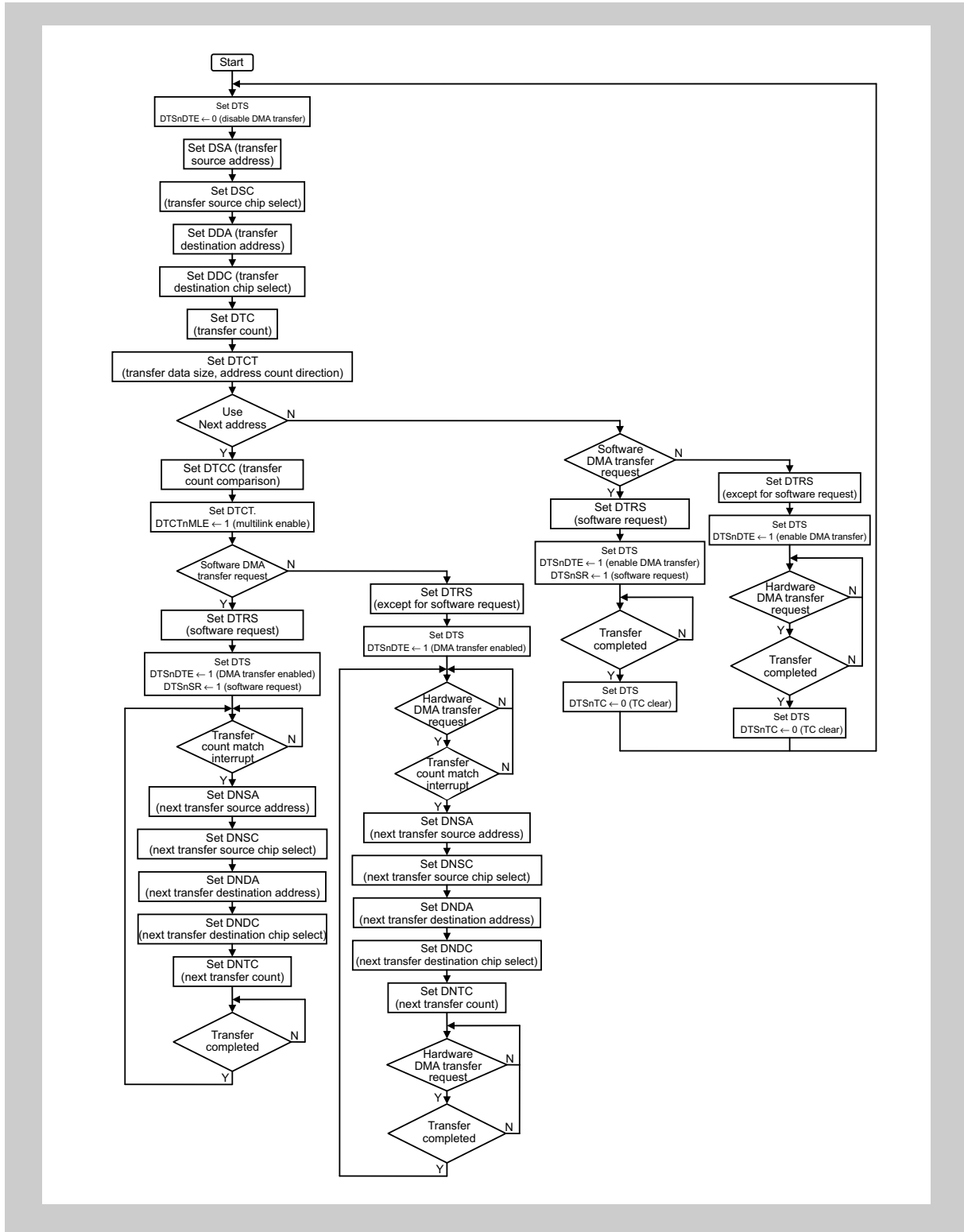

Figure 5-3 DMAC Transfer Setting Flow

5.6.2 DMAC Transfer Modes

The DMAC supports a single-transfer mode and single-step transfer mode as transfer modes.

In either mode, transfer is executed in 2 cycles (dual address transfer) and therefore, a read cycle and a write cycle are generated each time transfer is executed. In the case of 128-bit transfer, the read cycle is generated 4 times and the write cycle is generated 4 times, in that order.

Note that the bus is not locked. Consequently, a CPU-access cycle may interrupt between the read and write cycles, and between the 4 read cycles and 4 write cycles during 128-bit transfer.

(1) Single Transfer Mode (when Hardware DMA Transfer Request Is Generated)

When a hardware DMA transfer request is acknowledged, the amount of data specified as the unit of data transfer (8, 16, 32, or 128 bits) is transferred. Each time transfer of this amount is executed, the bus is released and the DMA controller waits for a DMA transfer request. The acknowledge n signal ($n = 7$ to 0), which indicates that a hardware DMA transfer request has been acknowledged, is also output at this time.

Transfer is executed once for each acknowledgement of a hardware DMA transfer request. This operation is repeated the number of times specified in DMA transfer count register n (DTCn) ($n = 7$ to 0).

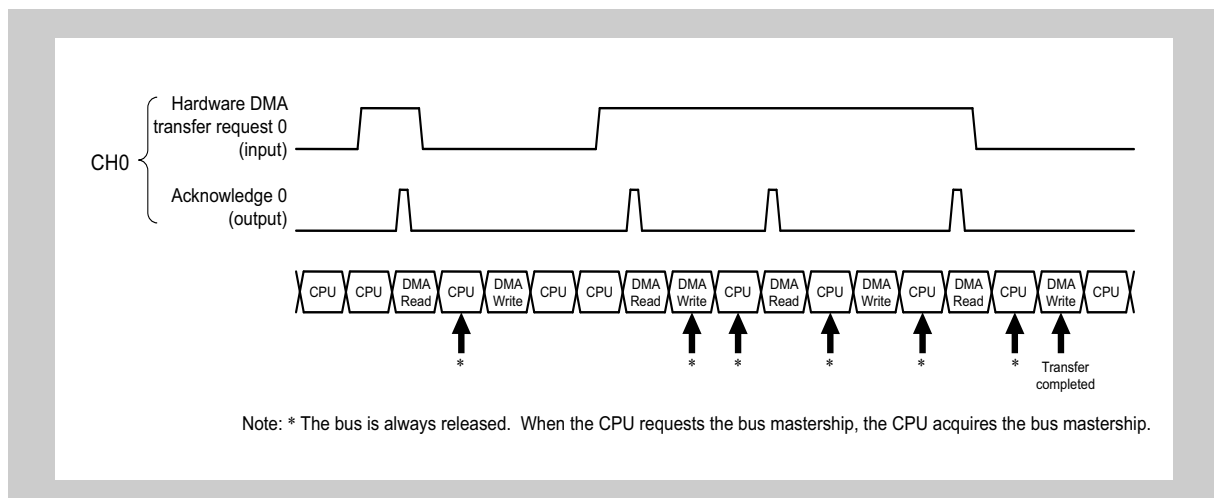

Figure 5-4 Example of Single Transfer (8/16/32 bits)

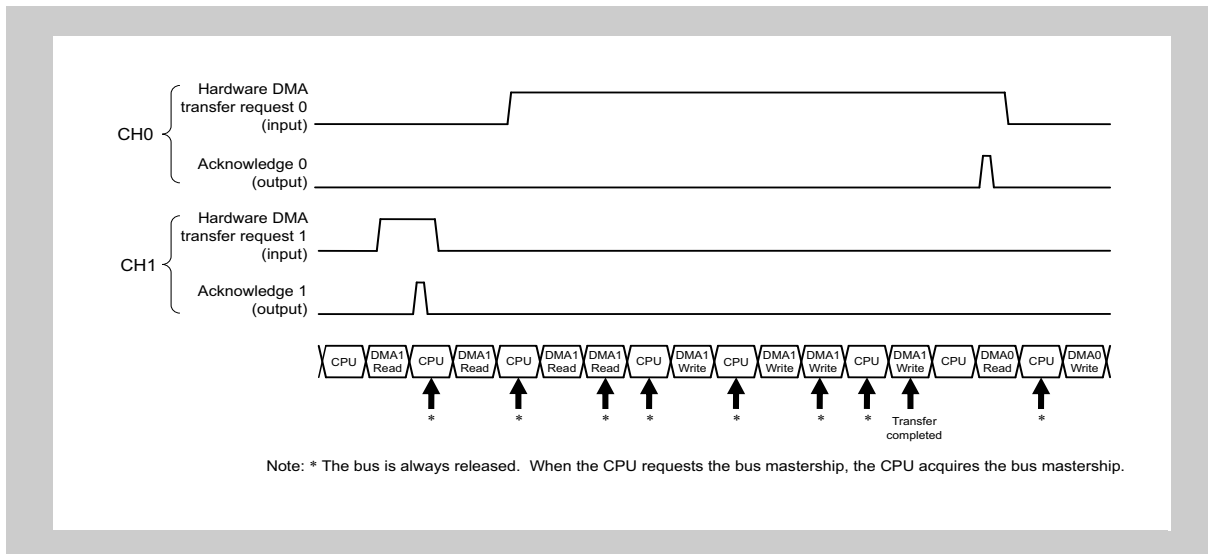

Figure 5-5 Example of Single Transfer (128 Bits, DMA Channel Priority: CH0 (High) > CH1 (Low))

(2) Single-Step Transfer Mode (when Software DMA Transfer Request Is Generated)

When a software DMA transfer request is acknowledged, the amount of data specified as the unit of data transfer (8, 16, 32, or 128 bits) is transferred. Each time transfer of this amount is executed, the bus is released and the DMA controller waits for a DMA transfer request. The acknowledge n signal (n = 7 to 0), which indicates that a hardware DMA transfer request has been acknowledged is not output at this time.

Once a software DMA transfer request has been acknowledged, this operation is repeated the number of times specified in DMA transfer count register n (DTCn) (n = 7 to 0). Priority is determined each time transfer is executed, so a DMA cycle for a channel having a higher priority may interrupt transfer in response to a software DMA request.

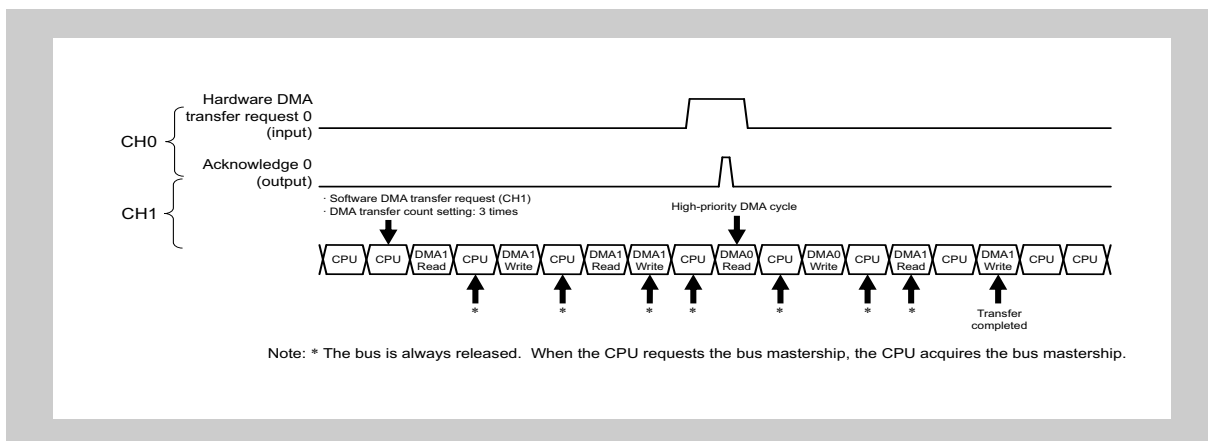

Figure 5-6 Example of Single-Step Transfer (8/16/32 Bits, DMA Channel Priority: CH0 (High) > CH1 (Low))

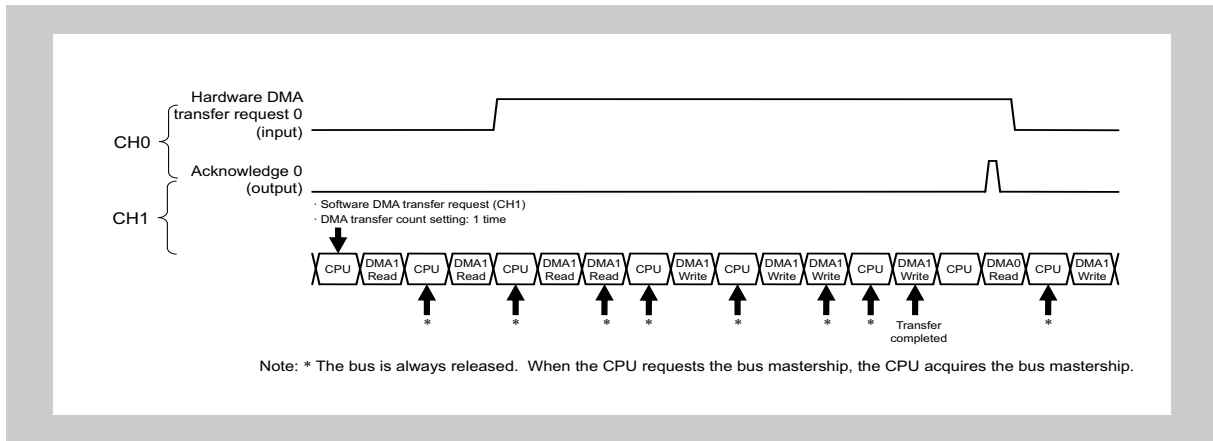

Figure 5-7 Example of Single-Step Transfer (128 Bits, DMA Channel Priority: CH0 (High) > CH1 (Low))

5.6.3 DMAC Channel Priority Control

The priority of each DMAC0 channel is fixed and the order of priority is as follows:

CH0 > CH1 > CH2 > CH3 > CH4 > CH5 > CH6 > CH7.

If another DMA transfer request with a high priority is generated while transfer is in progress, the request with the higher priority always takes precedence. This is also the case for software DMA requests, since the bus is also released after every DMA cycle in response to a software DMA transfer request.

The following figure shows an example where a next DMA transfer request with higher priority is generated while DMA transfer is in progress.

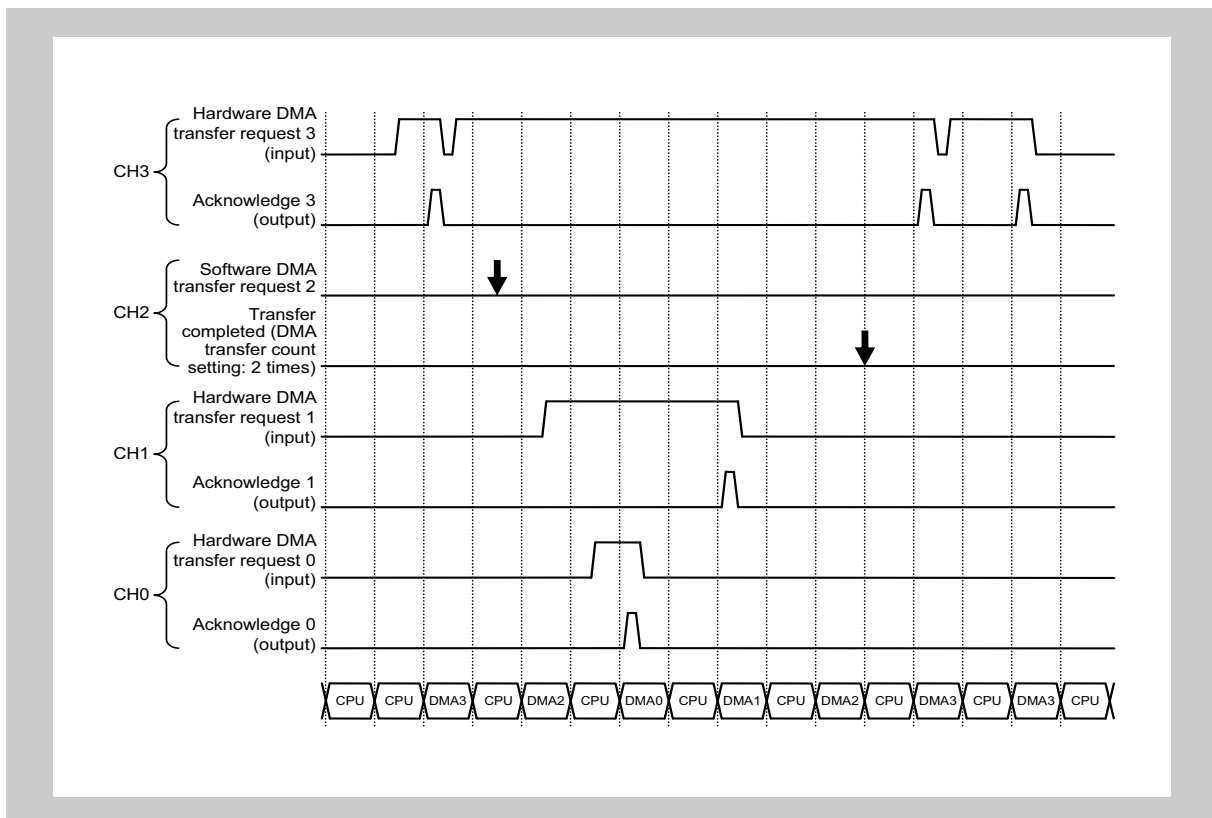

Figure 5-8 Example of Priority Control

5.6.4 Conditions for Validity of DMA Transfer Requests

Whether a request for DMA transfer on channel n is or is not acknowledged depends on the setting of the DTRC0ERR and DTRC0ADS bits of the DMA transfer request control register (DTRC0), the DTCTnMLE bit of the DMA transfer control register (DTCTn), and the DTSnTC and DTSnDTE bits of the DMA transfer status register (DTSn). The following table lists the relationship between the settings of these bits and whether a DMA transfer request is or is not acknowledged.

Table 5-6 Conditions for Validity of Requests for DMA Transfer on Channel n

Register.Bit Name	DTSn. DTSnDTE	DTSn. DTSnTC	DTCTn. DTCTnMLE	DTRC0. DTRC0ERR	DTRC0. DTRC0ADS	DMA Transfer Request
When DMA transfer is disabled	0	X	X	X	X	Invalid
When DMA transfer error occurs	X	X	X	1	X	Invalid
When DMA transfer is suspended	X	X	X	X	1	Invalid
When DMA transfer is completed (multilink disabled)	X	1	0	X	X	Invalid
When DMA transfer is completed/not completed (multilink enabled)	1	X	1	0	0	Valid
When DMA transfer is enabled	1	0	0	0	0	Valid

Note n = 0 to 7

5.6.5 Next Address Function

(1) Next Address Setting Registers

These registers are used to set the transfer information for the next transfer in advance while DMA transfer is in progress. This information is copied to the corresponding registers at the start of the last DMA cycle for the current transfer. The registers are as follows.

- DMA next source address register (DNSAnH/DNSAnL)
- DMA next source chip select register (DNStCn)
- DMA next destination address register (DNDAnH/DNDAnL)
- DMA next destination chip select register (DNDCn)
- DMA next transfer count register (DNtCn)

The most significant bit of each register for higher-order address bits is a “valid” bit that can be used to select whether or not to copy the transfer information to the “current” registers at the start of the last DMA cycle for the current transfer. Once the transfer information to be transferred next is copied to the current register, the “valid” bit is cleared.

(2) Processing upon DMA Transfer Completion when Using Next Address Function

Normally, upon completion of DMA transfer, the DMA transfer enable bit (DTSnDTE) is cleared at the same time the DMA transfer completion status bit (DTSnTC) of the DMA transfer status register (DTSn) is set, and subsequent DMA transfer requests are no longer acknowledged. However, if the multilink enable bit (DTCTnMLE) is set, DTSnDTE is not cleared and DMA transfer requests can be acknowledged even if DTSnTC is set.

Therefore, setting DTCTnMLE eliminates the steps of clearing DTSnTC and setting DTSnDTE upon completion of DMA transfer when the next address function is in use.

(3) Timing of Next-Address Settings

A new value can be written to a next address setting register at any time. However, to prevent a conflict between copying to the “current” register and writing by the user, make sure that setting of the next address setting register is completed before the start of the last DMA cycle for the current transfer.

We recommend that you use the DMA transfer count match interrupt as the trigger for setting the next address setting register. In this case, set the DMA transfer count compare register (DTCCn) so as to secure the time required for setting in the next address setting register.

5.6.6 Suspending/Resuming DMA Transfer

(1) Suspending or Resuming DMA Transfer for All Channels through Software

Subsequent DMA transfer can be suspended by setting the DMA transfer abort bit (DTRC0ADS) of the DMA transfer request control register (DTRC0).

When this is done during a DMA cycle, DMA transfer is suspended on completion of the ongoing DMA cycle. Note that the DMA transfer enable bit (DTSnDTE) and the software DMA transfer request bit (DTSnSR) of the DMA transfer status register (DTSn) are not cleared.

To resume a DMA transfer suspended in this way, clear the DTRC0ADS bit. To end DMA transfer, clear the DMA transfer request while the DTSnDTE bit is clear.

(2) Suspending or Resuming DMA Transfer by Using DMA Transfer Enable Bit (DTSnDTE)

Subsequent DMA transfer can be suspended by clearing the DMA transfer enable bit (DTSnDTE) of the DMA transfer status register (DTSn).

When this is done during a DMA cycle, DMA transfer is suspended on completion of the ongoing DMA cycle. Note that the software DMA transfer request bit (DTSnSR) for the DTSn is not cleared.

To resume a DMA transfer suspended in this way, set the DTSnDTE bit. To end DMA transfer, clear the DMA transfer request while the DTSnDTE bit is clear.

(3) Suspending or Resuming DMA Transfer by Using Software DMA Transfer Request Bit (DTSnSR)

Subsequent DMA transfer can be suspended by clearing the software DMA transfer request bit (DTSnSR) of the DMA transfer status register (DTSn).

When this is done during a DMA cycle, DMA transfer is suspended on completion of the ongoing DMA cycle.

To resume a DMA transfer suspended in this way, set the DTSnSR bit.

5.6.7 Error Responses

(1) Error Response Leading to Suspension of DMA Transfer

When an error occurs at the DMA transfer source or transfer destination, DMAC sets the DMA transfer abort bit (DTRC0ADS) of the DMA transfer request control register (DTRC0) to suspend subsequent DMA transfer. At the same time, the DMA transfer error status bit (DTRC0ERR) is set and a SysError exception is generated for the CPU. Once the user has confirmed that DTRC0ERR has been set, the DMA transfer error flag (DTSnER) of the DMA transfer status register (DTSn) can be used to identify the channel where the error occurred.

In this case, note that if the error response is acknowledged within the read cycle, the write cycle does not proceed but the transfer address and transfer count are updated.

(2) Canceling Transfer Suspension Due to Error Response

DMA transfer suspension can be reversed by clearing the DMA transfer abort bit (DTRC0ADS) and DMA transfer error status bit (DTRC0ERR) of the DMA transfer request control register (DTRC0).

Clear the DMA transfer enable bit (DTSnDTE) of the DMA transfer status register (DTSn) in advance, so that DMA transfer is not resumed after reversal of suspension. In the case of a software DMA transfer request, also clear the software DMA transfer request bit (DTSnSR).

5.7 DTFR Functions

Each DMA trigger factor register (DTFR) is used to select DMA trigger sources from among interrupt signals and to request DMA transfer by the DMAC. A DTFR_n register (n = 7 to 0) is included to select the signals to be used for DMA transfer requests for each channel from among the m = 108 input interrupt signals.

Caution If transfer is enabled (DTS_n.DTE = 1), writing to a DTFR might lead to the simultaneous start of transfer. To avoid this, use the DMA request clearing register (DRQCLR) to clear the transfer activating source flag just before transfer is enabled.

5.7.1 Features

Number of transfer sources DMA transfer requests (for 8 channels) are selected from among the m = 108 interrupt signals.

DMAC interface The DMA transfer request signal n (n = 7 to 0) is output.
The DMA transfer request signal n is cleared by an acknowledge signal from DMA.

CPU interface The last transfer signal from DMA is output as a CPU interrupt signal.

Clearing of transfer requests Register access to clear transfer request signals being sent to the DMA block is possible.

Confirming transfer requests Register access to check transfer request signals sent to the DMA block is possible.

5.8 DTFR Control Registers

5.8.1 DTFR_n (n = 0 to 7): DMA Trigger Factor Register

This 16-bit register selects an activating source to control the start of DMA transfer operations on the corresponding channel.

Access This register is readable/writable in 16-bit units.

Address DTFR0: FFFF 7B00_H, DTFR1: FFFF 7B02_H, DTFR2: FFFF 7B04_H,
DTFR3: FFFF 7B06_H, DTFR4: FFFF 7B08_H, DTFR5: FFFF 7B0A_H,
DTFR6: FFFF 7B0C_H, DTFR7: FFFF 7B0E_H

Initial value 0000_H

This register is initialized by a reset from any source.

15	14	13	12	11	10	9	8
DTFR _n REQEN	0	0	0	0	0	0	0
R/W	R	R	R	R	R	R	R
7	6	5	4	3	2	1	0
0	IFC _n [6:0]						
R	R/W	R/W	R/W	R/W	R/W	R/W	R/W

Bit Position	Bit Name	Function
15	DTFR _n REQEN	This bit enables or disables operation of the DMA activating source selector for channel n. 1: The source selector operates. 0: The source selector is stopped and corresponding DMA transfer request (DMARQ) is not issued. The settings of IFC6 to IFC0 are valid. Requests are always sampled.
6 to 0	IFC _n 6 to IFC _n 0	These bits select the transfer source. The set values are shown in Table 5-1, List of DMA Trigger Sources.

5.8.2 DRQCLR: DMA Request Clear Register

This 16-bit register is used to clear activating sources for DAM transfer.

Access This register is readable/writable in 16-bit units.

Address FFFF 7B40_H

Initial value 0000_H

This register is initialized by a reset from any source.

15	14	13	12	11	10	9	8
0	0	0	0	0	0	0	0
R	R	R	R	R	R	R	R
7	6	5	4	3	2	1	0
RQCR7	RQCR6	RQCR5	RQCR4	RQCR3	RQCR2	RQCR1	RQCR0
R/W	R/W	R/W	R/W	R/W	R/W	R/W	R/W

Bit Position	Bit Name	Function
7	RQCR7	This is a control bit for clearing the DMA request check register (DRQSTR.RQST7 bit). Setting 1 in this bit clears a transfer request held for channel 7 to 0.
6	RQCR6	This is a control bit for clearing the DMA request check register (DRQSTR.RQST6 bit). Setting 1 in this bit clears a transfer request held for channel 6 to 0.
5	RQCR5	This is a control bit for clearing the DMA request check register (DRQSTR.RQST5 bit). Setting 1 in this bit clears a transfer request held for channel 5 to 0.
4	RQCR4	This is a control bit for clearing the DMA request check register (DRQSTR.RQST4 bit). Setting 1 in this bit clears a transfer request held for channel 4 to 0.
3	RQCR3	This is a control bit for clearing the DMA request check register (DRQSTR.RQST3 bit). Setting 1 in this bit clears a transfer request held for channel 3 to 0.
2	RQCR2	This is a control bit for clearing the DMA request check register (DRQSTR.RQST2 bit). Setting 1 in this bit clears a transfer request held for channel 2 to 0.
1	RQCR1	This is a control bit for clearing the DMA request check register (DRQSTR.RQST1 bit). Setting 1 in this bit clears a transfer request held for channel 1 to 0.
0	RQCR0	This is a control bit for clearing the DMA request check register (DRQSTR.RQST0 bit). Setting 1 in this bit clears a transfer request held for channel 0 to 0.

Note Writing 0 to bits 15 to 0 is ignored.

5.8.3 DRQSTR: DMA Request Check Register

This 16-bit register is used to check the state of DMA transfer requests.

Access Only reading is possible and this must be in 16-bit units.

Address FFFF 7B44_H

Initial value 0000_H

This register is initialized by a reset from any source.

15	14	13	12	11	10	9	8
0	0	0	0	0	0	0	0
R	R	R	R	R	R	R	R
7	6	5	4	3	2	1	0
RQST7	RQST6	RQST5	RQST4	RQST3	RQST2	RQST1	RQST0
R	R	R	R	R	R	R	R

Bit Position	Bit Name	Function
7	RQST7	1: Request issued (DMA transfer request signal 7 is 1) 0: No request (DMA transfer request signal 7 is 0)
6	RQST6	1: Request issued (DMA transfer request signal 6 is 1) 0: No request (DMA transfer request signal 6 is 0)
5	RQST5	1: Request issued (DMA transfer request signal 5 is 1) 0: No request (DMA transfer request signal 5 is 0)
4	RQST4	1: Request issued (DMA transfer request signal 4 is 1) 0: No request (DMA transfer request signal 4 is 0)
3	RQST3	1: Request issued (DMA transfer request signal 3 is 1) 0: No request (DMA transfer request signal 3 is 0)
2	RQST2	1: Request issued (DMA transfer request signal 2 is 1) 0: No request (DMA transfer request signal 2 is 0)
1	RQST1	1: Request issued (DMA transfer request signal 1 is 1) 0: No request (DMA transfer request signal 1 is 0)
0	RQST0	1: Request issued (DMA transfer request signal 0 is 1) 0: No request (DMA transfer request signal 0 is 0)

Section 6 Memory Modules

This section describes the memory modules.

Products of this series are equipped with code flash memory, data flash memory, and RAM. Refer to Table 6-1, On-Chip Memory of V850E2/PG4-L Products for the memory size per product.

Code flash memory is programmable in two ways: by a flash programmer or by self-programming. Data flash memory is also programmable by a flash programmer.

If the dedicated flash programmer is to program on-chip memory, it has to be connected to the target system.

For self-programming, an application program is used instead of the dedicated flash programmer.

Flash memory is commonly used for the following purposes in the development environment and field of application:

- altering software after solder-mounting of the microcontroller on the target system,
- differentiating software in the small-scale production of a variety of models, and
- adjusting data when mass production starts.

Table 6-1 On-Chip Memory of V850E2/PG4-L Products

	μ PD70F4154	μ PD70F4155
Code flash	384 Kbytes	384 Kbytes
Data flash	16 Kbytes	16 Kbytes
On-chip RAM	24 Kbytes	24 Kbytes

6.1 Features

- Single-block erasure
- Communicating with the dedicated flash programmer via a serial interface
- Voltage for erasure/programming: erasure and programming only require a single power supply
- On-board programming
- Self-programming of the flash memory

6.1.1 Code Flash Memory

- ROM capacity: 384 Kbytes
- Erasure unit: single block (each block taking up 32 Kbytes)
- ECC function
Refer to section 9, Safety Functions, for details.
- Methods of erasure and programming
 - Support for Nexus
 - Support for serial interfaces (one-line UART and three-line CSI-HS)
 - Support for programming by the dedicated flash programmer
 - Support for self-programming
- Other supported functions
 - Prohibition of erasure and programming (security function)
 - Boot changeover (boot swapping)

Table 6-2 Capacity and Address Range of Code Flash Memory

Code Flash Capacity	Address
384 Kbytes	0000 0000 _H to 0005 FFFF _H

Note While writing to the code flash by the flash self-programming library (FSL), the interrupt processing or DMA transfer may be put on hold for a period of up to 33 CPU clock cycles

6.1.2 Data Flash Memory

- ROM capacity: 16 Kbytes
- Erasure unit: single block (each taking up 32 bytes)
- Programming unit: 2 bytes
- Reading unit: 2 bytes
- Methods of erasure and programming
 - Dedicated flash programmer

Table 6-3 Capacity and Address Range of Data Flash Memory

Data Flash Capacity	Address
16 Kbytes	0200 0000 _H to 0200 3FFF _H

Note While writing to the data flash by the data flash library (FDL), the interrupt processing or DMA transfer may be put on hold for a period of up to 35 CPU clock cycles.

Caution Only 2-byte read or write is possible for data flash. Attempt read or write in 4-byte or 1-byte units leads to a SYSERR exception if SEG_CONT.SEG_CONTEXTE = 1.

6.1.3 On-Chip RAM

- RAM capacity: 24 Kbytes

Table 6-4 Capacity and Address Range of RAM

RAM Capacity	Address
24 Kbytes	FEDF A000 _H to FEDF FFFF _H

Caution The size of the block for the code-flash memory in this product is 32 Kbytes. Since the size of the on-chip RAM is smaller than the block unit of the code-flash memory, divide the programming accordingly when programming using the on-chip RAM in self-programming mode.

6.2 Programming Environment

Programming, erasure, etc. are handled through a serial interface between the dedicated programmer and this product. Supply the operating clock for this product by mounting oscillators and capacitors to configure an oscillation circuit on the same board as this product.

6.3 Communications Methods

(1) Nexus communications

Transfer rate: 25 MHz (max.)

(2) LPD (single-pin debugging) communications

Transfer rate: 2Mbps (max., When the E1 emulator is used)

(3) One-line UART communications

Transfer rate: 1 Mbps (max.)

(4) Three-line CSI-HS communications

Transfer rate: 5 MHz (max.)

6.4 Handling of Pins

For on-board programming, the target system requires a connector for connection to the dedicated flash programmer.

When the transition is made to flash memory programming mode, all of the pins which are not used for flash memory programming are in the same state as just after a reset from normal operating mode (single-chip mode). Consequently, the port pins are all in the high-impedance state. Pin settings must be adjusted if this is not acceptable for an external device.

6.4.1 Power Supply

Supply the same voltage as in the normal operating mode.

Stabilize the power voltage by inserting capacitors between power-supply pins and ground during operations in flash memory programming mode (including flash-self programming).

6.4.2 Pins

Pins to be used for each interface are as follows:

- Nexus: FLMD0, $\overline{\text{RESET}}$, $\overline{\text{DCUTRST}}$, DCUTCK, DCUTMS, DCUTDI, DCUTDO, $\overline{\text{DCUTRDY}}$
- LPD (single-pin debugging): LPDIO, FLMD0, $\overline{\text{RESET}}$
- One-line UART: RxD/ TxD, FLMD0, $\overline{\text{RESET}}$
- Three-line CSI-HS: SI, SO, SCK, FLMD0, $\overline{\text{RESET}}$

When connecting pins for interfaces which are already connected to other devices on the board to the dedicated flash programmer, take care to avoid signal conflicts, abnormal operation of other devices, and so on.

6.4.3 Reset Pin

Connecting the reset signal of the dedicated flash programmer to the $\overline{\text{RESET}}$ pin, which in turn is connected to the reset-signal generation circuit on the board, leads to signal conflicts. To avoid these conflicts, isolate the pin's connection with the reset generation circuit.

A reset signal from the user system input during operation in flash memory programming mode can cause abnormal programming operation. Therefore, do not input any signals other than the reset signal from the dedicated flash programmer.

6.4.4 FLMD0 Pin

Input the high level on FLMD0 except for intervals over which pulses are input during operations in flash memory programming mode (programming, erasure, or reading). After the pulse input, keep the pin at the high level until flash-memory operations are completed.

6.4.5 Port Pins

All port pins other than those for communications with the dedicated flash programmer will be in the high-impedance state when the settings for flash-memory programming mode are made. No adjustment is required for these pins.

However, if a pin being in the high-impedance state is not acceptable for an external device to which it is connected, connect the port pin to EVDD or EVSS via a resistor.

6.5 Option-Setting Bytes

The “option bytes” specify product operation. Values of these bytes are programmed by using the dedicated flash programmer or a function for writing to them.

Operation of the product with option bytes erased is not guaranteed.

For details, refer to Section 6 OPBT0 - Option Byte Verification Register.

Caution When the chip is erased, the FOP (option byte) setting is also initialized (HEAPCLK = 48 MHz, PCLK = 1/4 HEAPCLK). Therefore, set the serial communication rate within the range shown below and re-set the FOP.

- One-line UART communications
Baud rate \leq 750 kbps
 - Three-line CSI-HS communications
FPCCK \leq 2 MHz
-

6.5.1 OPBT0 - Option Byte Verification Register

This register is used to check the settings of option bytes.

Access This register can be read in 32-bit units.

Address FF47 000C_H

Initial value FFFF FFF9_H The corresponding value is set when the source signal of any reset other than the software reset is generated.

31	30	29	28	27	26	25	24	23	22	21	20	19	18	17	16
FOP31	1	1	1	1	1	1	1	FOP23	FOP22	1	1	1	1	1	1
R	R	R	R	R	R	R	R	R	R	R	R	R	R	R	R
15	14	13	12	11	10	9	8	7	6	5	4	3	2	1	0
1	1	1	1	1	1	1	1	1	1	1	1	FOP3	FOP2	FOP1	1
R	R	R	R	R	R	R	R	R	R	R	R	R/W	R/W	R/W	R

Table 6-5 Option Byte Verification Register of V850E2/PG4-L Products

Bit Position	Bit Name	Function															
31	FOP31	Switches the JTAG port 0: Port function 1: JTAG (Nexus) When connecting the port to a development tool, set this bit to 1 (= disabled).															
23	FOP23	Enables or disables output of the toggled signal (TGLOUT) 0: TGLOUT is output from P8_0. 1: TGLOUT is not output from P8_0 (P8_0 operates as a port pin).															
22	FOP22	Sets the cycle of toggling for the toggled signal (TGLOUT) 0: 6.55 ms 1: 13.10 ms															
3	FOP3	Sets for the peripheral clock (PCLK) 0: HEAPCLK 1: HEAPCLK/2															
2, 1	FOP[2:1]	Sets the CPU clock (HEAPCLK) <table border="1" style="margin-left: 20px;"> <thead> <tr> <th>FOP2</th> <th>FOP1</th> <th>HEAPCLK</th> </tr> </thead> <tbody> <tr> <td>0</td> <td>0</td> <td>64 MHz</td> </tr> <tr> <td>0</td> <td>1</td> <td>80 MHz</td> </tr> <tr> <td>1</td> <td>0</td> <td>Setting prohibited</td> </tr> <tr> <td>1</td> <td>1</td> <td>48 MHz</td> </tr> </tbody> </table>	FOP2	FOP1	HEAPCLK	0	0	64 MHz	0	1	80 MHz	1	0	Setting prohibited	1	1	48 MHz
FOP2	FOP1	HEAPCLK															
0	0	64 MHz															
0	1	80 MHz															
1	0	Setting prohibited															
1	1	48 MHz															

6.6 Product Identification

(1) PRDNAME Register

This register provides identifying information for the product.

Access This register can be read in 32-bit units.

Address FF47 0028_H

Initial value 103A0100_H (version 1.00 of the μ PD70F4154)

103B0100_H (version 1.00 of the μ PD70F4155)

31	30	29	28	27	26	25	24	23	22	21	20	19	18	17	16
0	0	0	1	0	0	0	0	0	0	1	1	1	0	1	0/1
R	R	R	R	R	R	R	R	R	R	R	R	R	R	R	R
15	14	13	12	11	10	9	8	7	6	5	4	3	2	1	0
0	0	0	0	0/1	0/1	0/1	0/1	0/1	0/1	0/1	0/1	0/1	0/1	0/1	0/1
R	R	R	R	R	R	R	R	R	R	R	R	R	R	R	R

Table 6-6 PRDNAME Register Contents

Bit Position	Function						
31 to 12	<table border="1"> <thead> <tr> <th>Bits 31 to 12</th><th>Description</th></tr> </thead> <tbody> <tr> <td>103A0_H</td><td>μPD70F4154</td></tr> <tr> <td>103B0_H</td><td>μPD70F4155</td></tr> </tbody> </table>	Bits 31 to 12	Description	103A0 _H	μ PD70F4154	103B0 _H	μ PD70F4155
Bits 31 to 12	Description						
103A0 _H	μ PD70F4154						
103B0 _H	μ PD70F4155						
11 to 0	The information on the product version is set in these bits.						

(2) PRDSELH Register

This register provides identifying information for the product.

Access This register can be read in 32-bit units.

Address FF47 0024_H

Initial value FEDF A001_H

31	30	29	28	27	26	25	24	23	22	21	20	19	18	17	16
1	1	1	1	1	1	1	0	1	1	0	1	1	1	1	1
R	R	R	R	R	R	R	R	R	R	R	R	R	R	R	R
15	14	13	12	11	10	9	8	7	6	5	4	3	2	1	0
1	0	1	0	0	0	0	0	0	0	0	0	0	0	0	1
R	R	R	R	R	R	R	R	R	R	R	R	R	R	R	R

Table 6-7 PRDSELH Register Contents

Bit Position	Function				
31 to 8	<table border="1"> <thead> <tr> <th>31 to 8 Bits</th> <th>Description</th> </tr> </thead> <tbody> <tr> <td>FEDFA0_H</td> <td>Address where on-chip RAM starts (FEDF A000_H)</td> </tr> </tbody> </table>	31 to 8 Bits	Description	FEDFA0 _H	Address where on-chip RAM starts (FEDF A000 _H)
	31 to 8 Bits	Description			
FEDFA0 _H	Address where on-chip RAM starts (FEDF A000 _H)				
7 to 0	<table border="1"> <thead> <tr> <th>7 to 0 Bits</th> <th>Description</th> </tr> </thead> <tbody> <tr> <td>01_H</td> <td>Code flash memory (384 Kbytes)</td> </tr> </tbody> </table>	7 to 0 Bits	Description	01 _H	Code flash memory (384 Kbytes)
	7 to 0 Bits	Description			
01 _H	Code flash memory (384 Kbytes)				

(3) PRDSELL Register

This register provides identifying information for the product.

Access This register can be read in 32-bit units.

Address FF47 0020_H

Initial value 8000 10FF_H

31	30	29	28	27	26	25	24	23	22	21	20	19	18	17	16
1	0	0	0	0	0	0	0	0	0	0	0	0	0	0	0
R	R	R	R	R	R	R	R	R	R	R	R	R	R	R	R
15	14	13	12	11	10	9	8	7	6	5	4	3	2	1	0
0	0	0	1	0	0	0	0	1	1	1	1	1	1	1	1
R	R	R	R	R	R	R	R	R	R	R	R	R	R	R	R

Table 6-8 PRDSELL Register Contents

Bit Position	Function	
31 to 24	31 to 24 Bits	Description
	80 _H	Code flash memory (384 Kbytes)
23 to 8	23 to 8 Bits	Description
	0010 _H	Data flash memory (16 Kbytes)

6.7 Setting the FLMD Pin

Input the high level on the FLMD0 pin when flash-memory operations are to proceed. Use of the on-chip pull-up resistor is selectable by setting a bit in the FLMD control register (the FLMDCNT.FLMDPUP bit) to 1.

Table 6-9 List of FLMD Pin Setting Registers

Register Name	Symbol	Address
FLMD control register	FLMDCNT	FF43 8000 _H
FLMD protection command register	FLMDPCMD	FF43 8004 _H
FLMD protection error status register	FLMDPS	FF43 8008 _H

6.7.1 Registers

(1) FLMDCNT - FLMD Control Register

This eight-bit register specifies pulling the FLMD0 pin up or down. A requirement for writing in a specified sequence protects the register. When programming is not in the specified sequence, the FLMDPREPP bit in the FLMDPS register is set to 1 to indicate the protection error.

For details, refer to Section 6.7.2, Setting the FLMDCNT Register.

Access This register can be read/written in 8-bit units.

Address FF43 8000_H

Initial value 00_H

This register is initialized by a reset from any source.

7	6	5	4	3	2	1	0
0	0	0	0	0	0	0	FLMDPUP
R	R	R	R	R	R	R	R/W

Table 6-10 FLMDCNT Register Contents

Bit Position	Bit Name	Function
0	FLMDPUP	Specifies pulling up or pulling down for the FLMD0 pin 0: FLMD0 pin is pulled down 1: FLMD0 pin is pulled up

(2) FLMDPCMD - FLMD Protection Command Register

This is the protection command register for FLMDCNT register.

For details, refer to Section 6.7.2, Setting the FLMDCNT Register.

Access This register can be written in 8-bit units. The value read is always 00_H.

Address FF43 8004_H

Initial value Undefined

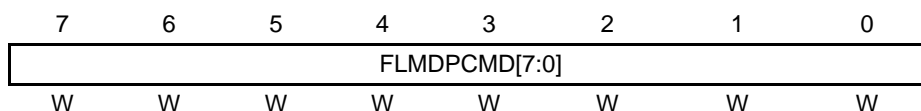

Table 6-11 FLMDPCMD Register Contents

Bit Position	Bit Name	Function
7 to 0	FLMDPCMD[7:0]	Protection commands to enable writing to FLMDCNT

(3) FLMDPS - FLMD Protection Error Status Register

This register verifies whether writing to the write protection register (FLMDCNT) was successful or not.

For details, refer to Section 6.7.2, Setting the FLMDCNT Register.

Access This register can be read in 8-bit units.

Address FF43 8008_H

Initial value 00_H

This register is initialized by a reset from any source.

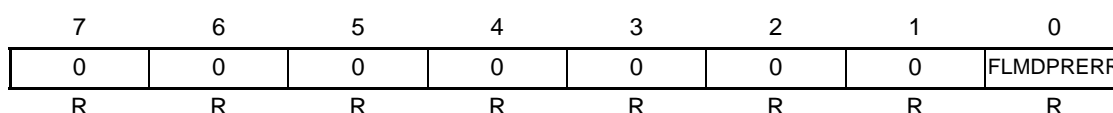

Table 6-12 FLMDPS Register Contents

Bit Position	Bit Name	Function
0	FLMDPRERR	Indicates whether writing to the write protection register (FLMDCNT) was successful or not 0: Writing succeeded 1: Writing failed

6.7.2 Setting the FLMDCNT Register

The FLMDCNT register is protected against writing. Specifically, writing is only effective when performed in the following sequence.

- STEP1** Write the fixed value (A5_H) to the protection register (FLMDPCMD).
- STEP2** Write the new setting to the corresponding register (FLMDCNT).
- STEP3** Write the inverse of the new setting to the corresponding register (FLMDCNT).
- STEP4** Write the new setting to the corresponding register (FLMDCNT).
- STEP5** Confirm that the setting has been written to the protected register by checking that the FLMDPS.FLMDPRERR bit is 0.

Writing to an FLMD pin setting register (for details, refer to Table 6-9, List of FLMD Pin Setting Registers) between steps 1 and 4 of the sequence specified above leads to failure in writing to the protected register (, which is indicated with the FLMDPS.FLMDPRERR set to 1).

In such a case, the sequence has to be restarted from step 1.

Access to registers other than FLMD pin setting registers can proceed during the sequence without preventing its completion.

The protection function operates as follows when the sequence is suspended.

- Suspension of the sequence due to the arrival of an interrupt
If an interrupt request is accepted while the above specified sequence for writing is in progress and the interrupt service routine does not access any of the FLMD pin setting registers (for details, refer to Table 6-9, List of FLMD Pin Setting Registers), the sequence is not obstructed. Writing to the protected register can proceed successfully on return from the interrupt service routine.
- Suspension of the sequence due to halting of the emulator
If the emulator is halted because it reached a break point, for example, while the above specified sequence for writing is in progress, the sequence of writing to the register is fully suspended until the emulator returns from the halted state to normal operation.
In other words, even access to an FLMD pin setting register (for details, refer to Table 6-9, List of FLMD Pin Setting Registers) while the emulator is halted does not obstruct the sequence of writing. Furthermore, access to an FLMD pin setting register does not lead to setting of the FLMDPS.FLMDPRERR bit.

Section 7 Clock Generation

The clock generator (CG) controls the internal system clocks that are supplied to individual on-board units such as the CPU.

It also monitors the input clock to detect abnormalities and has a baud-rate generator to produce the desired output clock signal on the CLKOUT pin.

7.1 Overview of Clock Generation

- Functional overview** Clock generation involves the following controls and functions.
- Oscillator
 - External resonator: 8 MHz (μ PD70F4155), 16 MHz (μ PD70F4154)
 - Clock monitoring (CLMA0 to CLMA2) blocks
 - CLMA0 monitors the WDTCLKI clock and generates reset signals. This product does not support the generation of interrupt-request signals by CLMA0.
 - CLMA1 monitors the internal system clock and generates reset and interrupt-request signals.
 - CLMA2 monitors the internal oscillator and generates reset and interrupt-request signals.
 - Clock output: The frequency of the signal output on the CLKOUT pin is adjustable.

Note For the output frequencies, their allowed range, and other parameters, refer to Section 6.5, Option-Setting Bytes, and to the Data Sheet.

7.2 Configuration

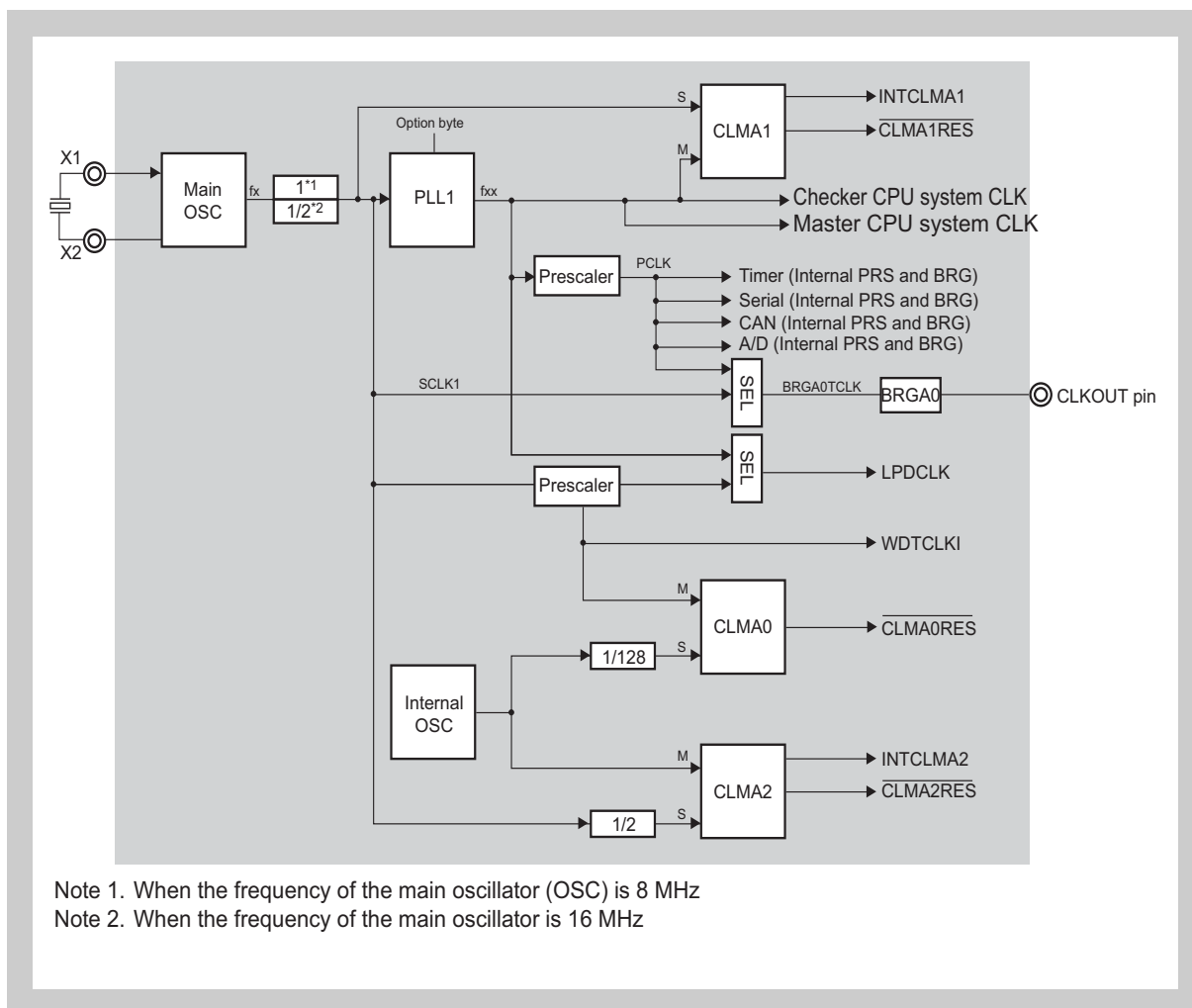

Figure 7-1 Clock Generating Circuit

7.3 Selecting the Input Clock Signal

The clock generator consists of an oscillator and PLL synthesizers and is capable of, generating internal system clocks at 48, 64, and 80 MHz when an external resonator (crystal oscillator or ceramic oscillator) running at 8 or 16 MHz is connected to the X1 and X2 pins.

For the oscillator to be connected to the X1 and X2 pins, refer to Table 7-1, Oscillators Connectable to the X1 and X2 Pins. The 8- or 16-MHz signal from the external resonator is input to PLL1, which produces a frequency-multiplied clock signal for supply that is supplied to the CPU as the operating clock and to peripheral I/O via the prescaler.

Table 7-1 Oscillators Connectable to the X1 and X2 Pins

Oscillators Connectable to the X1 and X2 Pins
8 MHz (μ PD70F4155)
16 MHz (μ PD70F4154)

Table 7-2 Operating Frequency

Internal System Clock	Peripheral Input-Output Clock (PCLK)	Frequency of External Resonator
48 MHz	24/48 MHz	8 MHz (μ PD70F4155) 16 MHz (μ PD70F4154)
64 MHz	32/64 MHz	
80 MHz	40/80 MHz	

Note For input frequency and multiplier settings, refer to Section 6.5, Option-Setting Bytes.

7.4 Clock Generating Circuit

The structure of the clock generating circuit is described below.

(1) Structure of Clock Generating Circuit

The circuit consists of the clock oscillation circuit and PLL1.

- Main oscillator circuit (Main OSC)

The clock signal f_x produced by the main oscillator circuit provides the clock for the main systems and is input to the PLL. The oscillator circuit requires the connection of an external resonator between X1 and X2.

- PLL1

The PLL1 circuit generates the clock signal for use in driving the microcontrollers. The clock signal output from PLL1 is divided by one or two, and then supplied to peripheral input and output.

Resetting the clock generating circuit

The clock generator is initialized by a reset from any source other than a software reset. After release from the reset state, operation is restarted in accord with the setting of the option byte.

7.5 Clock Output Function (CLKOUT)

The clock-output function handles the output of a clock signal from CLKOUT pin. The signal for output from the CLKOUT pin can be frequency-divided by the baud-rate generator.

The figure below is a schematic view of the clock output function.

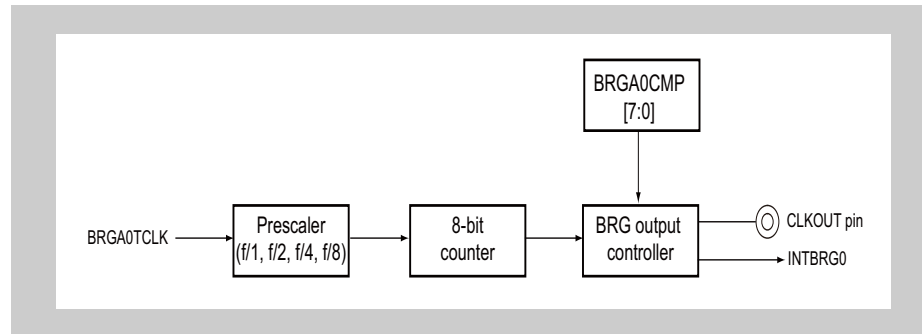

7.5.1 Baud-Rate Generator for CLKOUT Function (BRGA)

The baud-rate generator frequency-divides the clock signal it receives as input and can thus produce clock signals at various frequencies on the CLKOUT pin.

BRGA0 inverts the output signal on CLKOUT when the value of the baud-rate counter matches the setting of the BRGA0CMP[7:0] bits in the BRGA0CMP register. If BRGA0CTL.BRGA0ODIS = 1, the low level is output on CLKOUT.

When the counter reaches the value for comparison set in BRGA0CMP.BRGA0CMP[7:0], the BRGA0 interrupt (INTBRG0) is generated.

Note When BRGA0CMP.BRGA0CMP[7:0] = 00_H, the initial counting value is 01_H, and the sequence of counting is 02_H, 03_H, ... FE_H, FF_H, 00_H. Comparison after the overflow of the counter overflows produces a match.

Calculating the period of the signal from the baud-rate generator

- For BRGA0CMP.BRGA0CMP[7:0] = 00_H, the period of the output clock signal (CLKOUT) from the baud-rate generator is calculated from:

$$\text{CLKOUT period} = \text{counter clock cycle} \times 256 \times 2$$
- For BRGA0CMP.BRGA0CMP[7:0] = N = 01_H to FF_H, the period of the output clock signal (CLKOUT) from the baud-rate generator is calculated from:

$$\text{CLKOUT period} = \text{counter clock cycle} \times N \times 2$$

Clock supply The baud-rate generator BRGA0 provides the following clock input.

Table 7-3 Clock Source for BRGA0

BRGA0	Clock Source
BRGATCLK	Clock selected in the BRGCKCTL register (SCLK1 or PCLK)

Interrupt The BRGA interrupt is as indicated in the following table.

Table 7-4 BRGA Interrupt

BRGA Signal	Function	Connected to
INTBRG0	BRGA0 interrupt signal	Interrupt controller

Register addresses A list of addresses of the frequency output registers and clock monitor registers is given below.

Table 7-5 List of Registers in the Baud-Rate Generator for CLKOUT

Register Name	Symbol	Address
BRGA0 flag register	BRGA0FLG	FFFF FD00 _H
BRGA0 control register	BRGA0CTL	FF83 9008 _H
BRGA0 compare register	BRGA0CMP	FF83 900C _H
BRGA0 clock selection register	BRGCKCTL	FF42 0030 _H

7.5.2 BRGA Registers for CLKOUT Function

(1) BRGA0 Clock Selection Register (BRGCKCTL)

Register BRGCKCTL is an 8-bit register that selects the clock signal for input to the baud-rate generator (BRGA0).

Access This register can be read/written in 8-bit units.

Address FF42 0030_H

Initial value 00_H

This register is initialized by a reset from any source.

7	6	5	4	3	2	1	0
0	0	0	0	0	0	BRGCKSL1	BRGCKSL0
R	R	R	R	R	R	R/W	R/W

Table 7-6 BRGCKCTL Register Contents

Bit Position	Bit Name	Function												
1, 0	BRGCKSL1, BRGCKSL0	This register selects the input clock signal on the BRGATCLK signal line. <table border="1" style="margin-left: 20px;"> <thead> <tr> <th>BRGCKSL1</th> <th>BRGCKSL0</th> <th>Input Clock</th> </tr> </thead> <tbody> <tr> <td style="text-align: center;">0</td> <td style="text-align: center;">0</td> <td>Selects SCLK1 (OSC clock)</td> </tr> <tr> <td style="text-align: center;">0</td> <td style="text-align: center;">1</td> <td>Selects PCLK (peripheral clock)</td> </tr> <tr> <td colspan="2" style="text-align: center;">Other than the above</td> <td>Setting prohibited</td> </tr> </tbody> </table>	BRGCKSL1	BRGCKSL0	Input Clock	0	0	Selects SCLK1 (OSC clock)	0	1	Selects PCLK (peripheral clock)	Other than the above		Setting prohibited
BRGCKSL1	BRGCKSL0	Input Clock												
0	0	Selects SCLK1 (OSC clock)												
0	1	Selects PCLK (peripheral clock)												
Other than the above		Setting prohibited												

Caution Write to BRGCKCTL (selection of BRGA0 operation clock) while BRGA0 is stopped (the BRGA0CE bit of the BRGA0CTL register = 0).

(2) BRGA0 Control Register (BRGA0CTL)

Register BRGA0CTL is an 8-bit register that enables counting by the counter, sets the prescaler period, and controls the output of BRGA0.

The BRGA0ODIS and BRGA0CCS[1:0] bits can only be modified while the BRGA0CEF bit of BRGA0FLG register is set to 0.

Refer to the BRGA0FLG register for a description of the BRGA0CEF bit.

Access This register can be read/written in 8-bit units.

Address FF839008_H

Initial value 00_H

This register is initialized by a reset from any source.

7	6	5	4	3	2	1	0
0	0	0	BRGA0CE	0	BRGA0ODIS	BRGA0CCS1	BRGA0CCS0
R	R	R	R/W	R	R/W	R/W	R/W

Table 7-7 BRGA0CTL Register Contents

Bit Position	Bit Name	Function															
4	BRGA0CE	This bit enables or disables operation of the baud-rate counter 0: Baud-rate counter operation is disabled (INTBRG0 interrupts will not be generated). 1: Enable baud-rate counter operation (INTBRG0 interrupts will be generated).															
2	BRGA0ODIS	This bit controls output from BRGA0. 0: The signal from the baud-rate generator is output on the CLKOUT pin. 1: The low level (fixed) is output on the CLKOUT pin.															
1, 0	BRGA0CCS1, BRGA0CCS0	This bit selects the counter-clock cycle for the baud-rate generator. <table border="1" style="margin-left: 20px;"> <thead> <tr> <th>BRGA0CCS1</th> <th>BRGA0CCS0</th> <th>Counter-clock cycle</th> </tr> </thead> <tbody> <tr> <td>0</td> <td>0</td> <td>BRGATCLK/1</td> </tr> <tr> <td>0</td> <td>1</td> <td>BRGATCLK/2</td> </tr> <tr> <td>1</td> <td>0</td> <td>BRGATCLK/4</td> </tr> <tr> <td>1</td> <td>1</td> <td>BRGATCLK/8</td> </tr> </tbody> </table>	BRGA0CCS1	BRGA0CCS0	Counter-clock cycle	0	0	BRGATCLK/1	0	1	BRGATCLK/2	1	0	BRGATCLK/4	1	1	BRGATCLK/8
BRGA0CCS1	BRGA0CCS0	Counter-clock cycle															
0	0	BRGATCLK/1															
0	1	BRGATCLK/2															
1	0	BRGATCLK/4															
1	1	BRGATCLK/8															

- Caution 1. Only write to the bits BRGA0CTL.BRGA0ODIS, BRGA0CTL.BRGA0CCS[1:0] and BRGA0CMP.BRGA0CMP[7:0] while the baud-rate counter is stopped (BRGA0FLG.BRGA0CEF = 0). Only reading is possible while the baud-rate generator is operating. The level of the CLKOUT signal and timing of INTBRG0 interrupts become undefined if settings are modified during operations.
- Caution 2. To restart the baud-rate counter after it has stopped, read the BRGA0FLG.BRGA0CEF bit and confirm that the baud-rate counter is stopped (BRGA0FLG.BRGA0CEF = 0). The level of the CLKOUT signal and timing of INTBRG0 interrupts become undefined when the setting of the BRGA0CTL.BRGA0CE bit is 0 and 1 is written to BRGA0CTL.BRGA0CE bit while the baud-rate counter is not stopped (BRGA0FLG.BRGA0CEF = 1).
- Caution 3. BRGA0CTL.BRGA0CE is synchronized with BRGA0TCLK, so synchronization requires 3 clock cycles of BRGA0TCLK. For this reason, CLKOUT and the INTBRG0 interrupt are initialized (both signals are fixed to the low level) after 3 cycles of BRGA0TCLK by writing 0 to BRGA0CTL.BRGA0CE bit during operations, which stops the baud-rate counter. For the states of operation of the baud-rate counter, refer to the description of the BRGA0FLG.BRGA0CEF bit.
-

(3) BRGA0 Compare Register (BRGA0CMP)

BRGA0CMP register stores the baud-rate counter comparison value.

Access This register can be read/written in 8-bit units.

Address FF83900C_H

Initial value 00_H

This register is initialized by a reset from any source.

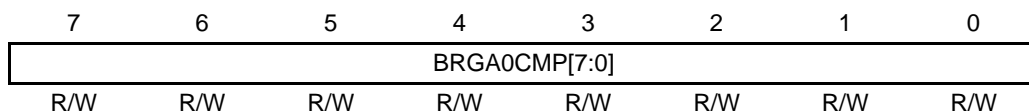

Table 7-8 BRGA0CMP Register Contents

Bit Position	Bit Name	Function
7 to 0	BRGA0CMP [7:0]	Value for comparison

(4) BRGA0 Flag Register (BRGA0FLG)

BRGA0FLG register indicates the current operation status of the baud-rate counter.

Access This register can be read in 8-bit units.

Address FFFF FD00_H

Initial value 00_H

This register is initialized by a reset from any source.

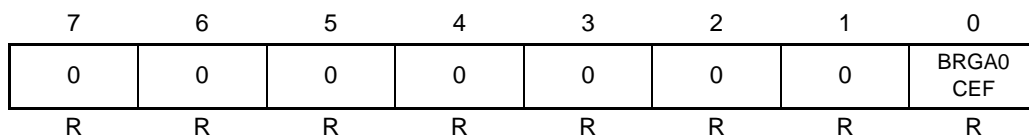

Table 7-9 BRGA0FLG Register Contents

Bit Position	Bit Name	Function
0	BRGA0CEF	This bit indicates the status of the baud-rate counter. 0: Baud-rate counter operation is stopped 1: Baud-rate counter is in operation

7.6 Single-Pin Debugging Clock (LPDCLK)

This is a dedicated operating clock for the single-pin debugging interface. The clock will not stop until the voltage is cut off once it starts operating during single-pin debugging (LPDRES = high level). Therefore, even when a reset is generated during single-pin debugging, the Main OSC and PLL1 never stop. However, the other clocks operate in the same way as in single-chip mode during single-pin debugging.

7.7 WDTA0 Count Clock (WDTCLKI)

WDTCLKI (SCLK1/32) is the input clock for WDTA0 in this product.

7.8 Clock Monitor A (CLMA_n) Function

This product has three instances of the clock monitor A.

7.8.1 Features of the Clock Monitors (CLMA_n; n = 0, 1, 2)

Table 7-10 Instances

Clock Monitor A	
Number of instances	3
Name	CLMA _n

Instances index n Throughout this section, the individual instances of a clock monitor A are identified by the index "n" (n = 0 to 2), for example, CLMA_nCTL0 for the control register 0 of CLMA_n.

<CLMA_n_base> The base address <CLMA_n_base> of each CLMA_n is listed in the table below.

Table 7-11 Register Base Address <CLMA_n_base>

CLMA _n	<CLMA _n _base> Address
CLMA0	FF80_2000 _H
CLMA1	FF80_3000 _H
CLMA2	FF80_4000 _H

Clock supply The monitored and the sampling clocks of all clock monitors A are listed in the following table:

Table 7-12 CLMA_n Clock Supply

Clocks for CLMA _n	Function	Connected to
CLMA0:		
CLMA0TSMP	Sampling clock for CLMA0	Internal OSC
CLMA0TMON	Clock for monitoring by CLMA0	WDTCLKI
CLMA1:		
CLMA1TSMP	Sampling clock for CLMA1	Main OSC
CLMA1TMON	Clock for monitoring by CLMA1	Internal system clock
CLMA2:		
CLMA2TSMP	Sampling clock for CLMA2	Main OSC
CLMA2TMON	Clock for monitoring by CLMA2	Internal OSC

Interrupts and reset outputs The interrupts and reset outputs of the CLMA_n are listed in the table below.

Table 7-13 CLMA_n Interrupts and Reset Outputs

CLMA _n Signal	Function	Connected to
CLMA0:		
CLMA0RES	CLMA0 error reset	Reset controller $\overline{\text{CLMA0RES}}$
CLMA1:		
CLMA1RES	CLMA1 error reset	Reset controller $\overline{\text{CLMA1RES}}$
CLMA1TI	CLMA1 error interrupt request	Interrupt controller INTCLMA1
CLMA2:		
CLMA2RES	CLMA2 error reset	Reset controller $\overline{\text{CLMA2RES}}$
CLMA2TI	CLMA2 error interrupt request	Interrupt controller INTCLMA2

Output signal CLMA_n output signals are listed in the following table.

Table 7-14 Output Signals from CLMA_n

CLMA _n Signal	Function	Connected to
CLMA0:		
CLMA0TERR	Error output signal from CLMA0	Safety guardian
CLMA0RES	Error reset signal from CLMA0	
CLMA1:		
CLMA1TERR	Error output signal from CLMA1	Safety guardian
CLMA1RES	Error reset signal from CLMA1	
CLMA2:		
CLMA2TERR	Error output signal from CLMA2	Safety guardian
CLMA2RES	Error reset signal from CLMA2	

7.8.2 CLMA Enable and Start-Up Options

(1) CLMA Enable

Monitoring of clock signals by a clock monitor is set up by setting the CLMA_nCTL1, CLMA_nCMPL, and CLMA_nCMPH registers, and starts when the CLMA_nCLME bit in the CLMA_nCTL0 register is set to 1.

7.8.3 Functional Overview

The clock monitor CLMA_n indicates an abnormal frequency of the monitored clock.

Features summary

The clock monitor has the following features:

- monitoring of the frequency of an input clock CLMA_nTMON by using a sampling clock CLMA_nTSMP
- indication of abnormal clock frequencies by the following means:
 - output of a reset request signal, or
 - output of an error signal in combination with the generation of an error interrupt request

The following figure shows the main components of the clock monitor.

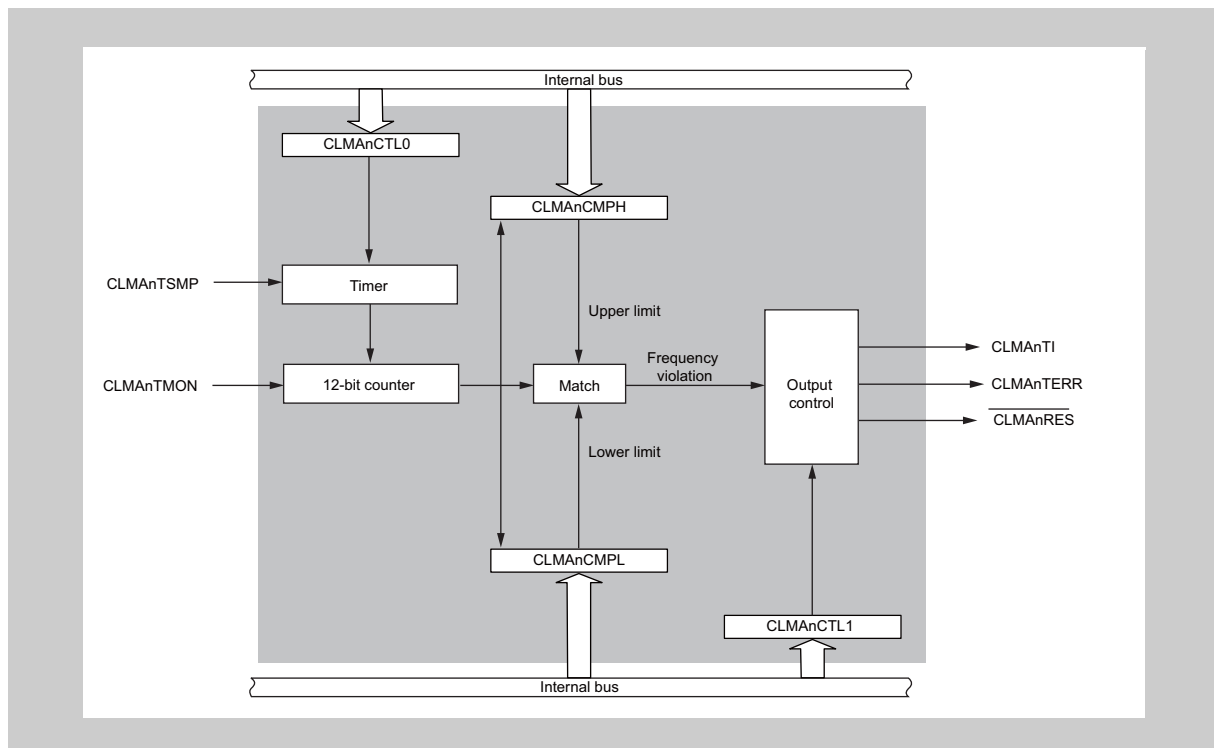

Figure 7-2 Block Diagram of the Clock Monitor A

Note Abnormalities cannot be detected while the sampling clock is stopped. It is recommended to use CLM0 to CLM2 for mutual monitoring.

7.8.4 Functional Description

The clock monitor CLMAn is used to ensure that the frequency of a clock (CLMAnTMON) stays between certain limits.

(1) Detection of Abnormal Clock Frequencies

- Method**
1. CLMAn counts the rising edges of the monitored clock CLMAnTMON within 16 cycles of the sampling clock CLMAnTSMP and then compares the counter with the configured thresholds:
 - CLMAnCMPL.CLMAnCMPL[11:0] defines the lower threshold.
 - CLMAnCMPH.CLMAnCMPH[11:0] defines the upper threshold.
 2. When CLMAnTMON stops or its frequency is too low, the counter falls below CLMAnCMPL.CLMAnCMPL[11:0].
 3. When the frequency of CLMAnTMON is too high, the counter exceeds CLMAnCMPH.CLMAnCMPH[11:0].

In both cases, CLMAn indicates an abnormal clock frequency as described in Section 7.8.4, (2) Indication of Abnormal Clock Frequency.

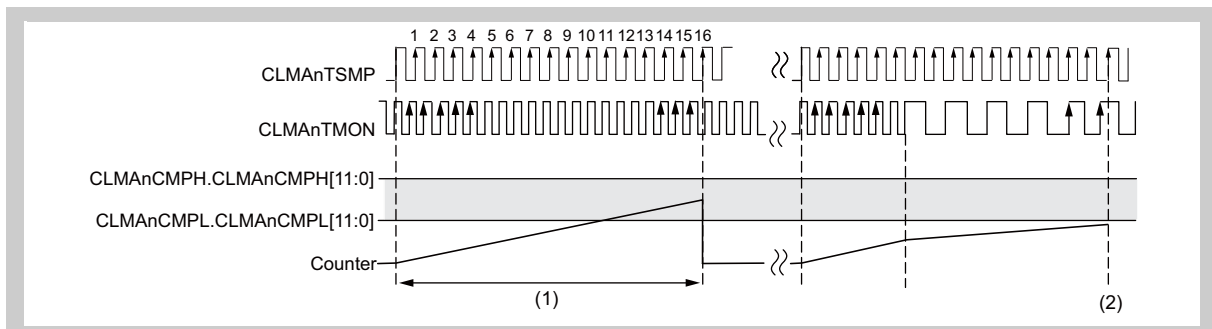

Figure 7-3 Example: $f_{\text{CLMAnTMON}}$ is low

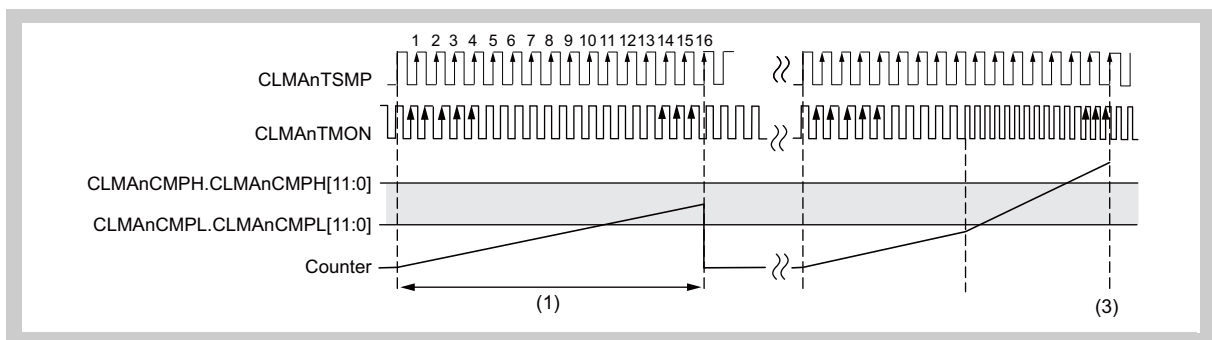

Figure 7-4 Example: $f_{\text{CLMAnTMON}}$ is high

Note When $f_{\text{CLMAnTMON}}$ changes within the sampling interval (16 cycles of the CLMAnTSMP clock), the counter might be within the valid range even though $f_{\text{CLMAnTMON}}$ has actually become too high or low.

The abnormal $f_{\text{CLMAnTMON}}$ is detected one sampling interval later.

(a) Calculating the Thresholds of CLMAnCMPL.CLMAnCMPL[11:0] and CLMAnCMPH.CLMAnCMPH[11:0]

The compare registers CLMAnCMPL and CLMAnCMPH are configured with the minimum and maximum number of clock cycles of CLMAnTMON that are assumed to be valid within 16 cycles of the sampling clock CLMAnTSMP.

The expected number of clock cycles is denoted by N.

$$\frac{16}{f_{\text{CLMAnTSMP}}} = \frac{N}{f_{\text{CLMAnTMON}}}$$

$$N = \frac{f_{\text{CLMAnTMON}}}{f_{\text{CLMAnTSMP}}} \times 16$$

Considering the allowed frequency deviations of CLMAnTMON and CLMAnTSMP, the threshold values can be calculated by the following formulas:

$$\begin{aligned} \text{Lower threshold} &= N_{\min} \\ &= \frac{f_{\text{CLMAnTMON}(\min)}}{f_{\text{CLMAnTSMP}(\max)}} \times 16 - 1 \end{aligned}$$

$$\begin{aligned} \text{Upper threshold} &= N_{\max} \\ &= \frac{f_{\text{CLMAnTMON}(\max)}}{f_{\text{CLMAnTSMP}(\min)}} \times 16 + 1 \end{aligned}$$

Note For examples of CLMAnCMPH and CLMAnCMPL registers of this product, refer to Table 7-16, Examples of CLMAnCMPH and CLMAnCMPL Register Settings.

- Minimum thresholds** The following restrictions must be taken into account:
- CLMAnCMPL \geq 0001_H
 - CLMAnCMPH \geq CLMAnCMPL + 0003_H

(2) Indication of Abnormal Clock Frequency

$f_{\text{CLMA}n\text{TMON}}$ too high $f_{\text{CLMA}n\text{TMON}}$ exceeding the upper threshold indicates clock abnormalities as follows:

1. The reset request signal $\overline{\text{CLMA}n\text{RES}}$ (active low) is being output.
2. The peripheral reset signal PERRES is being generated and is resetting CLMA n .

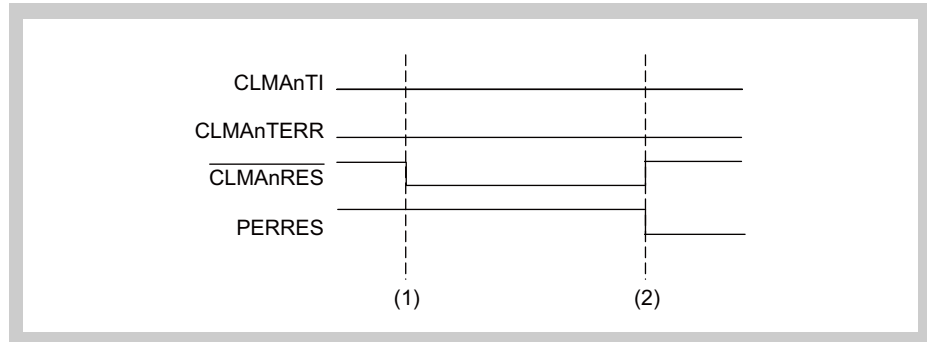

Figure 7-5 Indication of Clock Abnormality when $f_{\text{CLMA}n\text{TMON}}$ Rises above the Upper Threshold

$f_{\text{CLMA}n\text{TMON}}$ too low The response by CLMA n to $f_{\text{CLMA}n\text{TMON}}$ falling below the lower threshold is described by the entry in the table that corresponds to the current setting of CLMA n CTL1.CLMA n OSEL

Table 7-15 When $f_{\text{CLMA}n\text{TMON}}$ is too Low

CLMA n CTL1.CLMA n OSEL	Indication of Clock Abnormality when $f_{\text{CLMA}n\text{TMON}}$ Falls below the Upper Threshold
0	CLMA n outputs a reset-request signal ($\overline{\text{CLMA}n\text{RES}}$: active low). This is the same response as when $f_{\text{CLMA}n\text{TMON}}$ is too high; see the description above.
1	CLMA n outputs an error signal (CLMA n TERR: active high) and generates an error-interrupt request (CLMA n TI). <ul style="list-style-type: none"> • The error signal (CLMAnTERR) is set to the high level and remains there until CLMAn is reset (PERRES). • The error-interrupt request (CLMAnTI) is only generated once, even if the clock frequency remains too low.

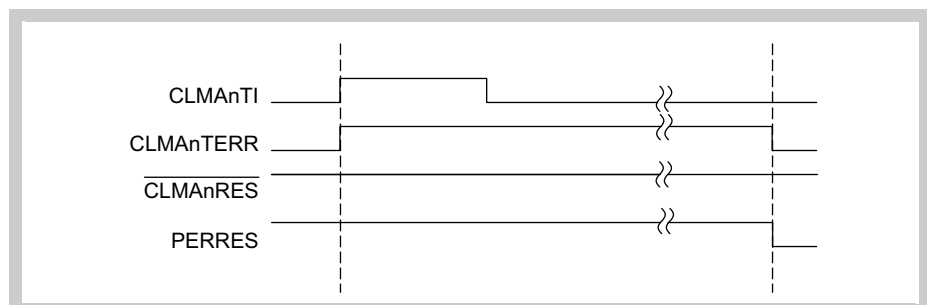

Figure 7-6 Indication of Clock Abnormality when $f_{\text{CLMA}n\text{TMON}}$ Falls below the Lower Threshold (when CLMA n CTL1.CLMA n OSEL = 1)

(3) Enabling CLMAn (Writing to the CLMAnCTL0 Register)

The control register (CLMAnCTL0) is the write-protection register and is used to enable CLMAn.

Note Once CLMAn is enabled, it cannot be disabled by software; it can only be disabled by a reset.

(a) Initial Value of the CLMAnCTL0 Register

The initial value of the CLMAnCTL0 register is 00_H. Using software to set the CLMAnCLME bit to 1 initiates CLMAn operation.

(b) Procedure for Writing to Enable CLMAn

Execute instructions in the sequence below to set the CLMAnCTL0 register to 01_H.

1. Write A5_H to the CLMAnPCMD register.
2. The following sequence is required for writing to the CLMAnCTL0 register.
 - Write 01_H to enable CLMAn.
 - Write the inverse of that value, i.e. FE_H.
 - Write the intended value (01_H) again.
3. Read the CLMAnCTL0 register.

If the value of the register is 01_H, CLMAn is enabled.

If this was not the value, check the settings in the CLMAnCTL0 register and in the write operation status register (CLMAnPS).

- If the value in the CLMAnPS register is 01_H, the instruction sequence was not executed correctly. Restart the sequence for enabling CLMAn from step 1.
- If the value in the CLMAnPS register is 00_H, write 00_H to the CLMAnPCMD register and only then re-execute the sequence from step 1.

(4) Examples of CLMA_nCM_{PH} and CLMA_nCM_{PL} Register Settings**Table 7-16 Examples of CLMA_nCM_{PH} and CLMA_nCM_{PL} Register Settings**

	Operating Frequency	Main OSC	Monitored Clock	Sampling Clock	CLMA _n CM _{PH} *1	CLMA _n CM _{PL} *1
CLMA0	48 MHz 64 MHz 80 MHz	8 MHz	WDTCLKI (Main OSC/32) (0.25 MHz)	Internal OSC/128 (0.063 MHz)	0049 _H	0039 _H
		16 MHz	WDTCLKI (Main OSC/2/32) (0.25 MHz)			
CLMA1		8 MHz	Internal system clock (80 MHz)	Main OSC (8 MHz)	00A5 _H	009B _H
		16 MHz		Main OSC/2 (8 MHz)		
		8 MHz	Internal system clock (64 MHz)	Main OSC (8 MHz)	0084 _H	007C _H
		16 MHz		Main OSC/2 (8 MHz)		
		8 MHz	Internal system clock (48 MHz)	Main OSC (8 MHz)	0063 _H	005D _H
		16 MHz		Main OSC/2 (8 MHz)		
CLMA2		8 MHz	Internal OSC (8 MHz)	Main OSC/2 (4 MHz)	0025 _H	001B _H
		16 MHz		(Main OSC/2)/2 (4 MHz)		

Note 1. These values are calculated on OSC is 8MHz±0.2%, Internal OSC is 8MHz±10%, and PLL jitter is ±200ps.

(5) Behavior on a Reset Due to CLMA_n Detecting an Error (CLMA_nRES)

A reset is generated and conveyed to the SGA to notify it of the error.

If the states of the main oscillator, PLL1 and the internal oscillator become normal at that time, the chip is released from the reset state after the flash reset sequence is finished, and the OSC stabilization time and PLL lock-up time have elapsed.

If any one of main oscillator, PLL1, the internal oscillator, or WDTCLK1 is stopped or in an abnormal state, the chip will not be released from the reset state.

Caution After CLMA_nRES is asserted, check whether the main oscillator, PLL1, internal oscillator, and WDTCLK1 are operating normally. To do so, check the RESF register and start the CLMA_n operating to monitor their frequencies when the CPU starts operating.

(6) Behavior (n = 1, 2) after a CLMA_n Error-Interrupt Request (CLMA_nTI; n = 1, 2)

(a) After a CLMA1 Error Interrupt Request (CLMA1TI)

The error signal is conveyed to the SGA. The CPU will not operate if its system clock is stopped. Operation of the CPU and peripheral functions in this case is not guaranteed.

(b) After a CLMA2 Error Interrupt Request (CLMA2TI)

The error signal is conveyed to the SGA. If the internal oscillator is stopped, even if oscillation of the main oscillator is abnormal, the problem will not be detectable by CLM0 or CLM1 so the operation of the CPU and peripheral functions cannot be guaranteed. If the internal OSC is stopped at that time even after the input of a reset, the flash reset sequence will not proceed, and the chip will not be released from the reset state.

7.8.5 Clock Monitor A Registers

Clock monitor A is controlled and operated by the following registers.

Register addresses The list of register addresses of clock monitor A is given below.

Table 7-17 List of Clock Monitor Registers

Register Name	Symbol	Address
CLMAn control register 0	CLMAnCTL0	<CLMAn_base> + 00 _H
CLMAn control register 1	CLMAnCTL1	<CLMAn_base> + 04 _H
CLMAn compare register L	CLMAnCMPL	<CLMAn_base> + 08 _H
CLMAn compare register H	CLMAnCMPH	<CLMAn_base> + 0C _H
CLMAn protection command register	CLMAnPCMD	<CLMAn_base> + 10 _H
CLMAn protection status register	CLMAnPS	<CLMAn_base> + 14 _H

<CLMAn_base> The base addresses <CLMAn_base> of the CLMAn are defined in Table 7-11, Register Base Address <CLMAn_base>.

(1) CLMAnCTL0 – CLMAn Control Register 0

This register is used to enable the clock monitor A (CLMAn).

Access This register can be read/written in 8-bit units.

Writing to this register is protected by a special sequence of instructions. For details, refer to Section 7.8.4, (3) Enabling CLMAn (Writing to the CLMAnCTL0 Register).

Address <CLMAn_base> + 00_H

Initial value 00_H

This register is initialized by a reset from any source.

7	6	5	4	3	2	1	0
0	0	0	0	0	0	0	CLMAn CLME
R	R	R	R	R	R	R	R/W

Table 7-18 CLMAnCTL0 Register Contents

Bit Position	Bit Name	Function
0	CLMAnCLME	Enables/disables the clock monitor: 0: Disable CLMAn 1: Enable CLMAn This bit can only be cleared by a reset.

(2) CLMA_nCTL1 – CLMA_n Control Register 1

This register specifies the signal to be output when the frequency of the clock signal being monitored (CLMA_nTMON) is beyond the specified range.

For details, refer to Section 7.8.4, (2) Indication of Abnormal Clock Frequency.

Access This register can be read/written in 1- or 8-bit units. It can only be written when CLMA_n is disabled (CLMA_nCTL0.CLMA_nCLME = 0).

Address <CLMA_n_base> + 04_H

Initial value 00_H

This register is initialized by a reset from any source.

7	6	5	4	3	2	1	0
0	0	0	0	0	0	0	CLMA _n OSEL
R	R	R	R	R	R	R	R/W

Table 7-19 CLMA_nCTL1 Register Contents

Bit Position	Bit Name	Function
0	CLMA _n OSEL	Specifies the signal(s) that are output when the frequency of CLMA _n TMON falls below the lower threshold: 0: Reset request signal $\overline{\text{CLMA}}\text{nRES}$ 1: Error interrupt request CLMA _n TI and error signal CLMA _n TERR

Caution When the Internal OSC is halted, an internal reset is not generated. Even when the CLMA_nCTL1.CLMA_nOSEL bit is set to 0 (reset request signal), SGA detects the halt of the Internal OSC and the ERROROUT pin outputs the low level.

(3) CLMAnCMPH – CLMAn Compare Register H

This register specifies the upper frequency threshold.

For details, refer to Section 7.8.4, (1)-(a), Calculating the Thresholds of CLMAnCMPL.CLMAnCMPL[11:0] and CLMAnCMPH.CLMAnCMPH[11:0].

Access This register can be read/written in 16-bit units. It can only be written when CLMAn is disabled (CLMAnCTL0.CLMAnCLME = 0).

Address <CLMAn_base> + 0C_H

Initial value 03FF_H

This register is initialized by a reset from any source.

15	14	13	12	11	10	9	8	7	6	5	4	3	2	1	0
0	0	0	0	CLMAnCMPH[11:0]											
R	R	R	R	R/W	R/W	R/W	R/W	R/W	R/W	R/W	R/W	R/W	R/W	R/W	R/W

Table 7-20 CLMAnCMPH Register Contents

Bit Position	Bit Name	Function
11 to 0	CLMAnCMPH [11:0]	Specifies the upper threshold. <ul style="list-style-type: none"> The recommended value: Refer to Table 7-16, Examples of CLMAnCMPH and CLMAnCMPL Register Settings. The minimum value: CLMAnCMPL + 0003_H

(4) CLMAnCMPL – CLMAn Compare Register L

This register specifies the lower frequency threshold.

For details, refer to Section 7.8.4, (1)-(a), Calculating the Thresholds of CLMAnCMPL.CLMAnCMPL[11:0] and CLMAnCMPH.CLMAnCMPH[11:0].

Access This register can be read/written in 16-bit units. It can be written only when CLMAn is disabled (CLMAnCTL0.CLMAnCLME = 0).

Address <CLMAn_base> + 08_H

Initial value 0001_H

This register is initialized by a reset from any source.

15	14	13	12	11	10	9	8	7	6	5	4	3	2	1	0
0	0	0	0	CLMAnCMPL[11:0]											
R	R	R	R	R/W	R/W	R/W	R/W	R/W	R/W	R/W	R/W	R/W	R/W	R/W	R/W

Table 7-21 CLMAnCMPL Register Contents

Bit Position	Bit Name	Function
11 to 0	CLMAnCMPL[11:0]	Specifies the lower threshold. <ul style="list-style-type: none"> The recommended value: Refer to Table 7-16, Examples of CLMAnCMPH and CLMAnCMPL Register Settings. The minimum value: 0001_H

(5) CLMAnPCMD – CLMAn Protection Command Register

This is the protection command register for CLMAnCTL0.

For details, refer to Section 7.8.4, (3) Enabling CLMAn (Writing to the CLMAnCTL0 Register).

Access This register can be written in 8-bit units.

Address <CLMAn_base> + 10_H

Initial value Undefined

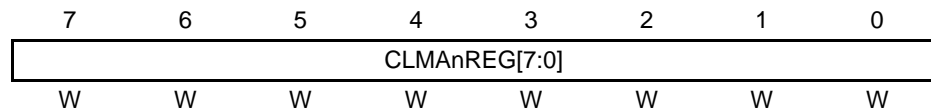

Table 7-22 CLMAnPCMD Register Contents

Bit Position	Bit Name	Function
7 to 0	CLMAnREG[7:0]	Protection command to enable writing to CLMAnCTL0 register.

(6) CLMAnPS – CLMAn Protection Status Register

This register verifies whether or not writing to the write protection register (CLMAnCTL0) was successful.

For details, refer to Section 7.8.4, (3) Enabling CLMAn (Writing to the CLMAnCTL0 Register).

Access This register can be read in 8-bit units.

Address <CLMAn_base> + 14_H

Initial value 00_H

This register is initialized by a reset from any source.

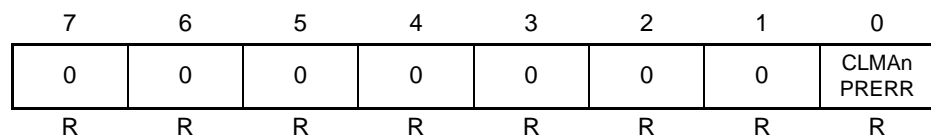

Table 7-23 CLMAnPS Register Contents

Bit Position	Bit Name	Function
0	CLMAnPRERR	Indicates if writing to the write protection register CLMAnCTL0 register was successful. 0: Writing succeeded. 1: Writing failed.

Section 8 Reset Controller

This section describes an overview of the reset controller.

8.1 Functional Overview

This product incorporates a number of system reset functions.

Features summary

A reset can be caused by the following events.

- External reset signal $\overline{\text{RESET}}$
Noise in the external reset signal is eliminated by an analog filter.
- Overflow of the watchdog timer ($\overline{\text{WDTA0RES}}$)
- Clock monitors reset ($\overline{\text{CLMA0RES}}$ to $\overline{\text{CLMA2RES}}$)
- Low voltage indicator reset ($\overline{\text{LVIRES}}$)
- Software reset (SWRES)
- Safety guardian reset ($\overline{\text{SGARES}}$)
- Self-diagnostic BIST reset ($\overline{\text{BISTRES}}$)
- Debug reset ($\overline{\text{DBRES}}$)

The following block diagram shows the main components of the reset controller.

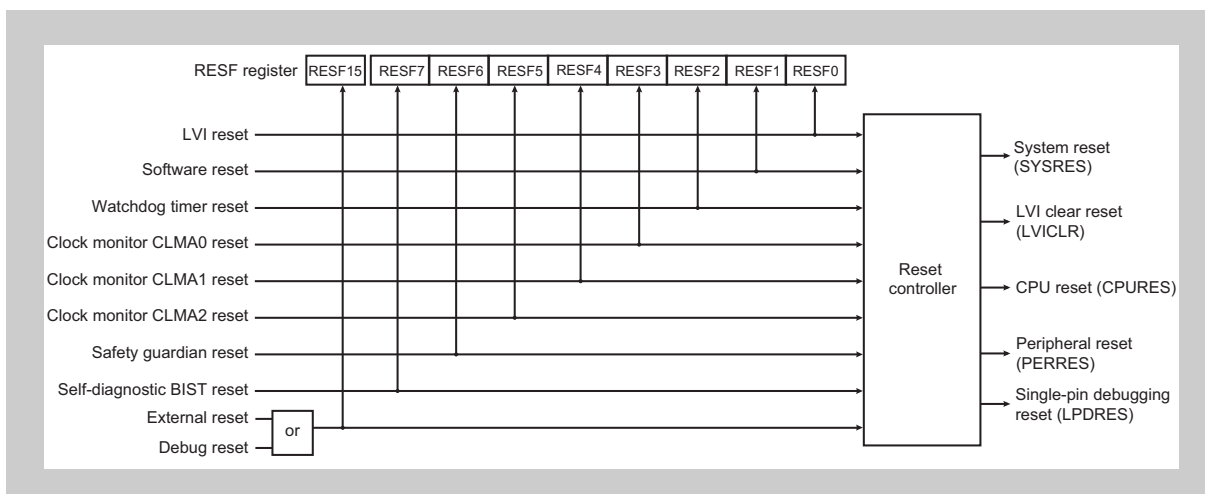

Figure 8-1 Block Diagram of the Reset Controller

Table 8-1 Reset Sources and Timing of Operations

Reset Input Source	Internal Reset Signals*1					Flash Reset Sequence Time*2	PLL Lock-up Time*2	OSC Stabilization Time*2	Self-Diagnostic BIST Execution*3	RESF Register
	SYSRES	LVICLR	CPURES	PERRES	LPDRES*5					
$\overline{\text{RESET}}$	√	√	√	√	–	√	√	–	√	RESF15*4
$\overline{\text{DBRES}}$	√	√	√	√	–	√	√	–	√	RESF15*4
$\overline{\text{BISTRES}}$	–	√	√	√	–	√	√	–	–	RESF7
$\overline{\text{SGARES}}$	–	√	√	√	–	√	√	–	√	RESF6
$\overline{\text{CLMA2RES}}$	–	√	√	√	–	√	√	√	√	RESF5
$\overline{\text{CLMA1RES}}$	–	√	√	√	–	√	√	√	√	RESF4
$\overline{\text{CLMA0RES}}$	–	√	√	√	–	√	√	√	√	RESF3
$\overline{\text{WDTA0RES}}$	–	√	√	√	–	√	√	–	√	RESF2
$\overline{\text{SWRES}}$	–	√	√	√	–	–	–	–	–	RESF1
$\overline{\text{LVIRES}}$	–	–	√	√	–	√	√	√	√	RESF0

Note 1. (–) The signal is not available as an internal reset signal. (√) The signal is available as an internal reset signal.

Note 2. (–) The time is not considered. (√) The time is considered by the internal hardware counter.

Note 3. (–) Self-diagnostic BIST is not executed on release from the reset state. (√) Self-diagnostic BIST is executed on release from the reset state.

Note 4. All other RESF flags are cleared by SYSRES ($\overline{\text{RESET}}/\overline{\text{DBRES}}$).

Note 5. For a list of the reset sources, refer to section 8.1 (1), Internal Reset Signals.

(1) Internal Reset Signals

The reset controller manages the generation of all internal reset signals upon occurrence of reset requests from various reset sources.

- **System reset SYSRES**
The system reset is generated by an external reset or the debug reset. SYSRES is applied to all microcontroller components.
- **CPU reset CPURES**
The CPU reset is generated by all reset sources. CPURES is applied to the master and checker CPU sub-systems (such as DMA and INTC).
- **LVI clear reset LVICLR**
The LVI clear reset is generated by all reset sources except the $\overline{\text{LVIRES}}$.
- **Peripheral reset PERRES**
The peripheral reset is generated by all reset sources.
- **Single-pin debugging reset LPDRES**
The single-pin debugging reset (LPDRES) is a dedicated reset signal for use in single-pin debugging. LPDRES is de-asserted when the power supply is turned on. Once LPDRES is de-asserted, it remains in the same state until the power supply is shut down or DCUTRST goes to the high level.

(2) Timing of De-Assertion of the External Reset Signal after the Power Supply is Turned on

After the power supply is turned on, the external reset signal has to be kept at the low level for more than 6 ms to secure the set up time for internal regulator.

8.2 Functional Description

8.2.1 Reset Flags

The reset flag register RESF provides reset flags for each reset source.

If a reset has occurred, the assigned flag is set. This way the source of the reset can be evaluated.

All flags in RESF are only cleared by SYSRES or by software clear request via the RESFC register. Thus, the operation of these registers is cumulative: each reset source sets its own flag, independent of all others.

8.2.2 Low-Voltage Indicator (LVI)

The low-voltage indicator circuit (LVI) permanently compares the power supply voltage VDD for the internal regulator with the LVI internal reference voltage V_{LVI} .

If VDD falls below the internal reference voltage ($V_{DD} < V_{LVI}$), the internal reset signal \overline{LVIRES} or the interrupt signal INTLVI is generated.

Additionally, the \overline{LVIRES} flag RESF.RESF0 is set.

RESF.RESF0 is not automatically cleared, if VDD exceeds V_{LVI} . It is cleared by

- setting RESFC.RESFC0 = 1
- SYSRES

LVI reference voltage For the specification of the internal reference voltage (V_{LVI}), refer to Section 27.6.16, POF/LVI Characteristics.

Generation of \overline{LVIRES} The generation of an interrupt instead of \overline{LVIRES} is selectable.

The following figure shows the timing of \overline{LVIRES} and changes to RESF.RESF0.

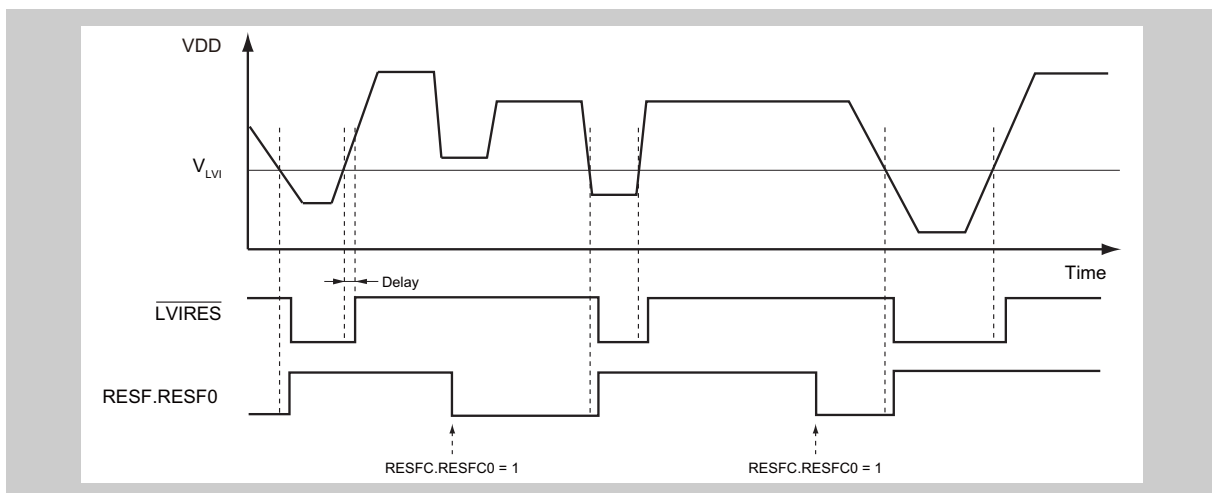

Figure 8-2 LVI Reset Timing

Delay A delay time is induced between VDD crossing the V_{LVI} level and assertion of \overline{LVIRES} setting of RESF.RESF0.

8.2.3 External $\overline{\text{RESET}}$

A system reset is performed when a low level signal is applied to the $\overline{\text{RESET}}$ pin.

SYSRES clears the RESF register to 8000_H. The RESF.RESF15 bit represents the external $\overline{\text{RESET}}$ event.

The RESF.RESF15 bit is not automatically cleared. It is cleared by

- setting RESFC.RESFC15 = 1

The $\overline{\text{RESET}}$ signal is passed through an analog noise filter to prevent erroneous resets due to noise.

The following figure shows the timing when an external reset is performed. It explains the effect of the noise eliminator.

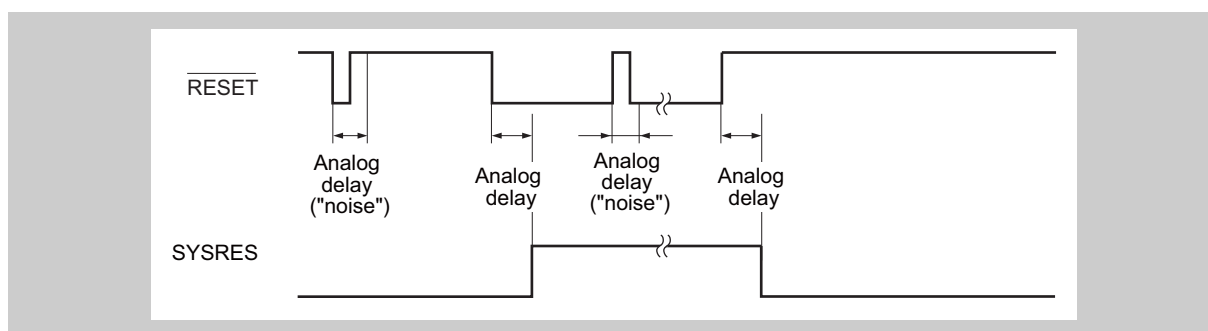

Figure 8-3 External $\overline{\text{RESET}}$ Timing

The analog delay is caused by the analog filter. The filter regards pulses up to a certain width as noise and suppresses them.

For the noise-cancelling intervals, see Table 2-51, List of Noise-Cancelling Intervals and Sampling Clock for Noise Cancellation, and for the minimum $\overline{\text{RESET}}$ pulse width, see Section 27.6.5, Reset Timing.

8.2.4 Watchdog Timer Reset

The watchdog timer can be configured to generate a reset if the watchdog time expires. After a watchdog reset, RESF.RESF2 for the watchdog timer reset flag (WDTA0RES) is set. RESF.RESF2 is not automatically cleared. It is cleared by

- setting RESFC.RESFC2 = 1
- SYSRES

8.2.5 Software Reset

The software reset SWRES can be asserted by setting SWRESA.SWRESA = 1.

RESF.RESF1 is not automatically cleared. It is cleared by

- setting RESFC.RESFC1 = 1
- SYSRES

8.2.6 Clock Monitor Reset

The clock monitors supervise the various internal clock signals. On detecting deviation of a clock signal from the expected range, the corresponding monitor generates a reset.

- $\overline{\text{CLMA0RES}}$: A failure in the main oscillation circuit is being detected.
- $\overline{\text{CLMA1RES}}$: A failure in PLL1 is being detected.
- $\overline{\text{CLMA2RES}}$: A failure in internal OSC is being detected.

Upon a clock monitor reset, the respective reset flags in the RESF register are set.

These flags are not cleared automatically. They are cleared by

- setting $\text{RESFC.RESFC3} = 1$ for $\overline{\text{CLMA0RES}}$, $\text{RESFC.RESFC4} = 1$ for $\overline{\text{CLMA1RES}}$, and $\text{RESFC.RESFC5} = 1$ for $\overline{\text{CLMA2RES}}$, respectively.
- SYSRES

8.2.7 Self-Diagnostic BIST Reset

Self-diagnostic BIST is usually executed after release from any reset source (except SWRES). This kind of reset is generated after self-diagnostic BIST to initialize the circuits that are the target of self-diagnostic BIST.

The generation of BISTRES is indicated by RESF.RESF7.

RESF.RESF7 is not automatically cleared. It is cleared by

- setting RESFC.RESFC7 = 1
- SYSRES

8.2.8 Safety Guardian Reset

The safety guardian (SGA) collects all internal error signals from different monitoring units.

All error inputs connected to the SGA are able to generate the $\overline{\text{SGARES}}$ reset signal.

After a safety guardian reset, the safety guardian reset flag RESF.RESF6 is set.

RESF.RESF6 is not automatically cleared. It is cleared by

- setting RESFC.RESFC6 = 1
- SYSRES

8.2.9 Reset Flag Evaluation

After any CPU reset (CPURES), the software starts at the reset vector which is always located at address 0000 0000_H.

Because each reset source will set its respective reset flag, if the reset flag register RESF is equal to 0000_H, a faulty software is assumed.

The reset flag register (RESF) can be evaluated as described below.

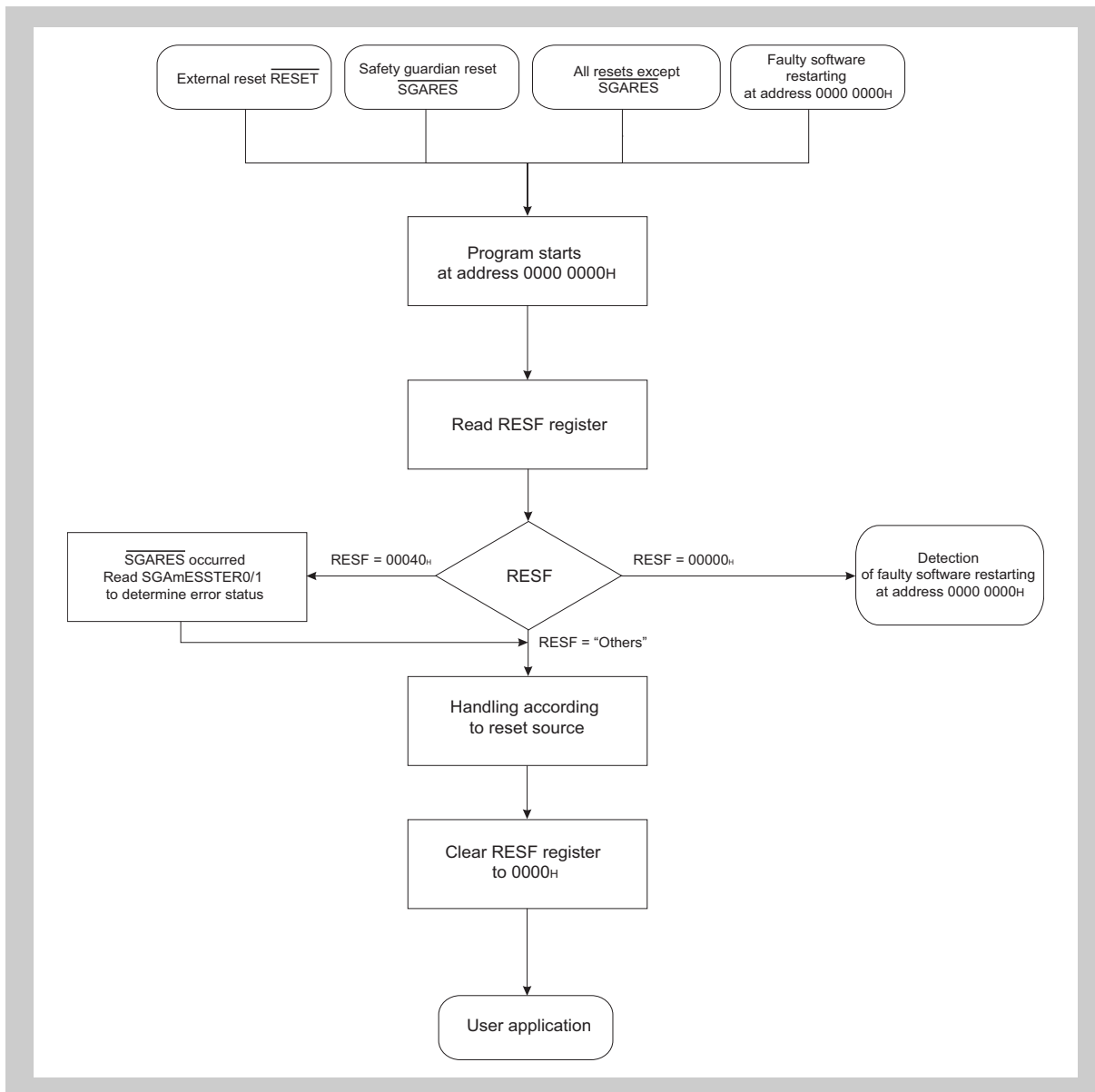

Figure 8-4 Procedure for Evaluating and Handling the Reset Flag

8.2.10 Protection for Registers of the Reset Controller

The write-protected registers are protected from inadvertent write access due to the execution of erroneous program code, etc.

Write access to write-protected registers is only possible within a special sequence of instructions shown below.

1. Write the fixed value $A5_H$ to the protection command register CSCPCMD.
2. Write the desired value to the protected register.
3. Write the bit-wise inversion of desired value to the protected register.
4. Write the desired value to the protected register.
5. Verify successful write of the desired value to the protected register by checking that $CSCPS.CSCPRERR = 0$.

In case of any access to the reset-related registers between steps 1 to 4 of the above sequence of instructions, the write to the protected register fails (indicated by $CSCPS.CSCPRERR = 1$) and the entire sequence of instructions has to be restarted from step 1.

Within the special sequence of instructions described above, it is allowed to access other registers, except the reset-related registers, without disrupting the protection sequence.

In case the protection sequence is interrupted, the protection mechanism operates as follows.

- Interrupts during protection sequence
If an interrupt is acknowledged within the above protection sequence and the interrupt service routine does not access any reset-related registers, the protection sequence is not disrupted. The write to the protected register can be successfully completed after returning from the interrupt service routine.

8.3 Registers

This section contains a description of all registers of the reset controller.

8.3.1 Overview of Reset Controller Registers

The reset controller is controlled and operated by the following registers.

Table 8-2 List of the Reset Controller Registers

Register Name	Symbol	Address
Reset flag registers		
Reset source register	RESF	FF42 0020 _H
Reset source set register	RESFS	FF42 0024 _H
Reset source clear register	RESFC	FF42 0028 _H
Software reset control register		
Software reset register	SWRESA	FF42 002C _H
Protection command registers		
Protection command register	CSCPCMD	FF42 0014 _H
Protection status register	CSCPS	FF42 0018 _H

Caution The respective registers include bits to which no function is allocated. Do not write values other than 0 to these bits, because operation cannot be guaranteed if this is done.

8.3.2 Details of Reset Controller Registers

(1) RESF - Reset Source Register

This register contains information about which type of resets occurred since the last SYSRES (RESET/DBRES).

Each following reset condition sets the corresponding flag in the register. For example, if a clock monitor $\overline{\text{CLMA0RES}}$ occurs after a watchdog timer reset $\overline{\text{WDTA0RES}}$, this register reads 000C_H .

Access This register can be read in 16-bit units.

Address $\text{FF42 } 0020_\text{H}$

Initial value 8000_H

This register is initialized by SYSRES ($\overline{\text{RESET/DBRES}}$).

15	14	13	12	11	10	9	8	7	6	5	4	3	2	1	0
RESF15	0	0	0	0	0	0	0	RESF7	RESF6	RESF5	RESF4	RESF3	RESF2	RESF1	RESF0
R	R	R	R	R	R	R	R	R	R	R	R	R	R	R	R

Table 8-3 RESF Register Contents

Bit Position	Bit Name	Function
15	RESF15	External reset flag 0: The $\overline{\text{RESET/DBRES}}$ reset is not being generated 1: The $\overline{\text{RESET/DBRES}}$ reset is being generated
7	RESF7	Self-diagnostic BIST reset flag 0: The $\overline{\text{BISTRES}}$ reset is not being generated 1: The $\overline{\text{BISTRES}}$ reset is being generated This flag will always be set after the execution of self-diagnostic BIST. The state of the flag is retained as long as self-diagnostic BIST is not executed again.
6	RESF6	Safety guardian reset flag 0: The $\overline{\text{SGARES}}$ reset is not being generated 1: The $\overline{\text{SGARES}}$ reset is being generated
5	RESF5	Clock monitor CLMA2 reset flag 0: The $\overline{\text{CLMA2RES}}$ reset is not being generated 1: The $\overline{\text{CLMA2RES}}$ reset is being generated
4	RESF4	Clock monitor CLMA1 reset flag 0: The $\overline{\text{CLMA1RES}}$ reset is not being generated 1: The $\overline{\text{CLMA1RES}}$ reset is being generated
3	RESF3	Clock monitor CLMA0 reset flag 0: The $\overline{\text{CLMA0RES}}$ reset is not being generated 1: The $\overline{\text{CLMA0RES}}$ reset is being generated
2	RESF2	Watchdog timer WDTA0 reset flag 0: The $\overline{\text{WDTA0RES}}$ reset is not being generated 1: The $\overline{\text{WDTA0RES}}$ reset is being generated
1	RESF1	Software reset flag 0: The $\overline{\text{SWRES}}$ reset is not being generated 1: The $\overline{\text{SWRES}}$ reset is being generated
0	RESF0	Low voltage indicator reset flag 0: The $\overline{\text{LVIRES}}$ reset is not being generated 1: The $\overline{\text{LVIRES}}$ reset is being generated

Caution If the generation of a reset and writing to the RESFC register are in contention, the setting for generation of the reset takes priority.

Note After writing to the RESFS and RESFC registers, actual reflection of the written value in the register takes at least 6 cycles of the PLL input clock. If a next value is written within less than 6 cycles, the value may not be reflected in the register.

(2) RESFC - Reset Source Clear Register

This register clears the reset flags of the RESF register.

Access This register can be read/written in 16-bit units. When read, the value returned is 0000_H.

Address FF42 0028_H

Initial value 0000_H

This register is initialized by a reset from any source.

	15	14	13	12	11	10	9	8	7	6	5	4	3	2	1	0
RESF	0	0	0	0	0	0	0	RESF	RESF	RESF	RESF	RESF	RESF	RESF	RESF	RESF
C15								C7	C6	C5	C4	C3	C2	C1	C0	
R/W	R	R	R	R	R	R	R	R/W	R/W	R/W	R/W	R/W	R/W	R/W	R/W	R/W

Table 8-4 RESFC Register Contents

Bit Position	Bit Name	Function
15	RESFC15	Controls clearing of the external reset flag (the RESF.RESF15 bit). 0: No effect (writing 0 to the bit does not affect the flag). 1: RESF.RESF15 is cleared
7	RESFC7	Controls clearing of the self-diagnostic BIST reset flag (the RESF.RESF7 bit). 0: No effect (writing 0 to the bit does not affect the flag). 1: RESF.RESF7 is cleared
6	RESFC6	Controls clearing of the safety guardian reset flag (the RESF.RESF6 bit). 0: No effect (writing 0 to the bit does not affect the flag). 1: RESF.RESF6 is cleared
5	RESFC5	Controls clearing of the clock monitor CLMA2 reset flag (the RESF.RESF5 bit). 0: No effect (writing 0 to the bit does not affect the flag). 1: RESF.RESF5 is cleared
4	RESFC4	Controls clearing of the clock monitor CLMA1 reset flag (the RESF.RESF4 bit). 0: No effect (writing 0 to the bit does not affect the flag). 1: RESF.RESF4 is cleared
3	RESFC3	Controls clearing of the clock monitor CLMA0 reset flag (the RESF.RESF3 bit). 0: No effect (writing 0 to the bit does not affect the flag). 1: RESF.RESF3 is cleared
2	RESFC2	Controls clearing of the watchdog timer WDTA0 reset flag (the RESF.RESF2 bit). 0: No effect (writing 0 to the bit does not affect the flag). 1: RESF.RESF2 is cleared
1	RESFC1	Controls clearing of the software reset flag (the RESF.RESF1 bit). 0: No effect (writing 0 to the bit does not affect the flag). 1: RESF.RESF1 is cleared
0	RESFC0	Controls clearing of the low voltage indicator reset flag (the RESF.RESF0 bit). 0: No effect (writing 0 to the bit does not affect the flag). 1: RESF.RESF0 is cleared

(3) RESFS - Reset Source Set Register

This register is for testing of the RESF register. Even if the flag corresponding to a reset source is set in the RESF register, the corresponding reset will not be generated.

Access This register can be read/written in 16-bit units. When read, the value returned is 0000_H.

Address FF42 0024_H

Initial value 0000_H

This register is initialized by a reset from any source.

	15	14	13	12	11	10	9	8	7	6	5	4	3	2	1	0
RESF	0	0	0	0	0	0	0	0	RESF	RESF	RESF	RESF	RESF	RESF	RESF	RESF
S15									S7	S6	S5	S4	S3	S2	S1	S0
R/W	R	R	R	R	R	R	R	R	R/W	R/W	R/W	R/W	R/W	R/W	R/W	R/W

Table 8-5 RESFS Register Contents

Bit Position	Bit Name	Function
15	RESFS15	Sets the external reset flag (RESF.RESF15). 0: No effect (writing 0 to the bit does not affect the flag). 1: RESF.RESF15 is set
7	RESFS7	Sets the self-diagnostic BIST reset flag (RESF.RESF7). 0: No effect (writing 0 to the bit does not affect the flag). 1: RESF.RESF7 is set
6	RESFS6	Sets the safety guardian reset flag (RESF.RESF6). 0: No effect (writing 0 to the bit does not affect the flag). 1: RESF.RESF6 is set
5	RESFS5	Sets the clock monitor CLMA2 reset flag (RESF.RESF5). 0: No effect (writing 0 to the bit does not affect the flag). 1: RESF.RESF5 is set
4	RESFS4	Sets the clock monitor CLMA1 reset flag (RESF.RESF4). 0: No effect (writing 0 to the bit does not affect the flag). 1: RESF.RESF4 is set
3	RESFS3	Sets the clock monitor CLMA0 reset flag (RESF.RESF3). 0: No effect (writing 0 to the bit does not affect the flag). 1: RESF.RESF3 is set
2	RESFS2	Sets the watchdog timer WDTA0 reset flag (RESF.RESF2). 0: No effect (writing 0 to the bit does not affect the flag). 1: RESF.RESF2 is set
1	RESFS1	Sets the software reset flag (RESF.RESF1). 0: No effect (writing 0 to the bit does not affect the flag). 1: RESF.RESF1 is set
0	RESFS0	Sets the low voltage indicator reset flag (RESF.RESF0). 0: No effect (writing 0 to the bit does not affect the flag). 1: RESF.RESF0 is set

8.3.3 Details of Software Reset Control Registers

(1) SWRESA - Software Reset Register

This register is used to generate a software reset SWRES.

Access This register can only be written in 8-bit units. When read, the value returned is 00_H.

Writing to this register is protected by a special sequence of instructions by using the protection command register CSCPCMD. For details, refer to the Section 8.2.10, Protection for Registers of the Reset Controller.

Address FF42 002C_H

Initial value 00_H

This register is initialized by a reset from any source.

7	6	5	4	3	2	1	0
0	0	0	0	0	0	0	SWRESA
R	R	R	R	R	R	R	W

Table 8-6 SWRESA Register Contents

Bit Position	Bit Name	Function
0	SWRESA	Software reset control 0: No effect (writing 0 to the bit does not lead to a software reset). 1: A software reset SWRES is generated.

Caution Do not use the software reset when data flash memory is operated.

Note After 1 is written to this register, actual execution of the reset takes up to two cycles of the internal oscillator.

8.3.4 Details of Protection Command Registers

(1) CSCPCMD - Protection Command Register

This register is the protection command register for the write protected reset controller registers.

Access This register can be written in 8-bit units.

When read, the value returned is 0.

Address FF42 0014_H

Initial value 00_H

This register is initialized by a reset from any source.

7	6	5	4	3	2	1	0
0	0	0	0	0	0	0	0
W	W	W	W	W	W	W	W

For details, see Section 8.2.10, Protection for Registers of the Reset Controller

Table 8-7 CSCPCMD Register Contents

Bit Position	Bit Name	Function
7 to 0	–	Protection commands to enable writing to write protected reset controller registers.

(2) CSCPS - Protection Status Register

This register shows the status of the protection sequence operated by the CSCPCMD.

Access This register can be read in 8-bit units.

Writing to this register is ignored.

Address FF42 0018_H

Initial value 00_H

This register is initialized by a reset from any source.

7	6	5	4	3	2	1	0
0	0	0	0	0	0	0	CSCPRERR
R	R	R	R	R	R	R	R

Table 8-8 CSCPS Register Contents

Bit Position	Bit Name	Function
0	CSCPRERR	Protected write sequence error monitor 0: No protection error 1: Protection error occurred

8.4 Power-on Flag/Low Voltage Indicator (POF/LVI)

8.4.1 Overview of the POF/LVI Function

POF function The power-on flag (the POF.POF bit) is set to 1 if the power supply voltage for the internal regulator (VDD) falls below the POF detection voltage.

LVI function The LVI sets the LVI detection flag (LVISF) to 1 and generates an interrupt signal (INTLVI) or a reset signal (LVIRESET) if the power supply voltage for the internal regulator (VDD) falls below the LVI detection voltage.

- The LVIMD bit in the LVICNT register is used to select the output of an interrupt or reset signal in response to detection of a low voltage.
- An internal reset signal is output when the power-supply voltage falls below the detection voltage (this is the case when LVICNT.LVIMD = 1).
- An interrupt request signal is generated when the power-supply voltage falls below the detection voltage (this is the case when LVICNT.LVIMD = 0).
- An interrupt request signal is generated when the power-supply voltage rises above the detection voltage (this is the case when LVICNT.LVIMD = 0).

Table 8-9 LVI Interrupt Request

LVI Signal	Function	Connected to
INTLVI	LVI interrupt signal (for detection of voltage falling below and rising above the given level)	Interrupt controller INTLVIO

8.4.2 Operation

(1) POF Detection

Monitoring of the power supply voltage for the internal regulator leads to setting of the power-on flag (the POF.POF bit) if the power supply voltage for the internal regulator falls below the prescribed detection voltage (both when the voltage is supplied and when the voltage is cut off).

Note The state (operating or stopped) is not specifiable by software.

Caution When the power supply voltage for the internal regulator (VDD) falls below the POF detection voltage, an external reset must be input. Wait more than 6 ms before de-asserting the external reset signal after individual power supply voltage exceeds the lower limit on guaranteed range of operating voltage.

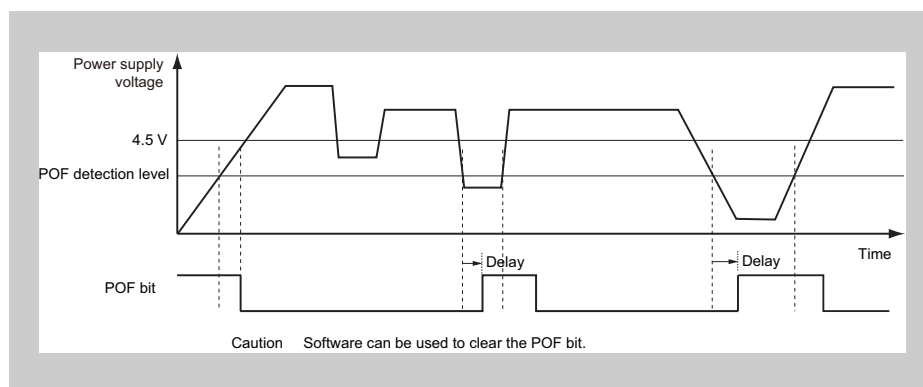

Figure 8-5 Example of POF Operations

(2) LVI Operation

Monitoring of the power supply voltage for the internal regulator after setting the LVICNT bit to 1 can be used to generate an interrupt signal (INTLVI) or a reset signal (LVIRES) in accord with the setting of the LVICNT.LVIMD bit when the power supply voltage for the internal regulator falls below the prescribed detection voltage.

(a) Using the LVI for the Output of Reset Signals

<Starting LVI operation>

1. Set the interrupt controller so that the interrupt (INTLVI) is masked.
2. Set the LVICNT.LVICNT bit so that a detection voltage exists.
3. Software handles at least 350 μ s of waiting time.
4. Test the value of the LVISF.LVISF bit to confirm that the voltage currently being supplied is above the detection level.
5. Set the LVICNT.LVIMD bit to 1 (selecting the output of a reset signal).

Caution After the LVICNT.LVIMD bit has been set to 1, further changes to the LVICNT register are not possible until the generation of a request for a different type of reset.

<Stopping LVI operation>

Stopping LVI operation is not possible except through the generation of a reset of a different type.

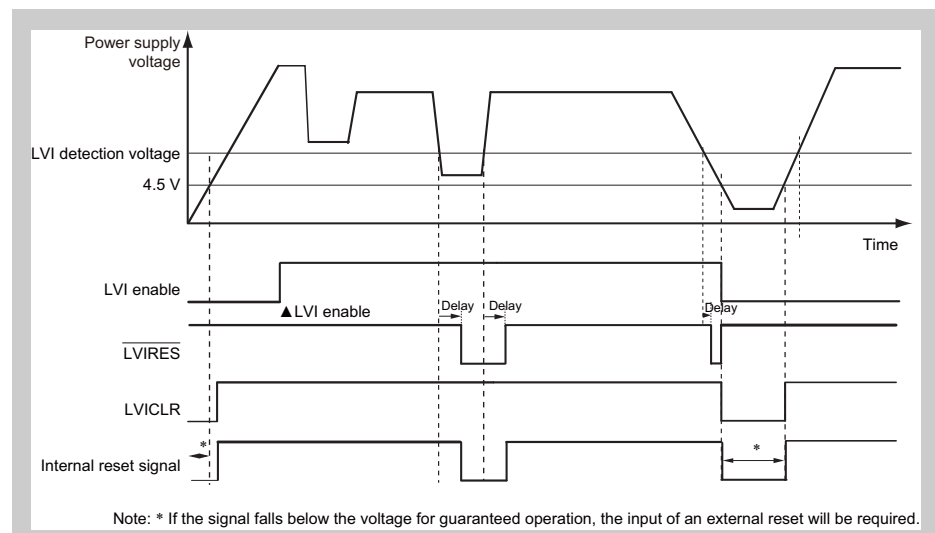

Figure 8-6 Example of LVI Operation (when the LVICNT.LVIMD Bit = 1)

(b) Using the LVI for the Output of Interrupt Request Signals

<Starting LVI operation>

1. Set the interrupt controller so that the interrupt (INTLVI) is masked.
2. Set the LVICNT.LVIMD bit to 0 (selecting the output of an interrupt). Since this is the initial setting, explicitly making this setting is not generally required.
3. Set the LVICNT.LVICNT bit so that a detection voltage exists.
4. Software handles at least 350 μ s of waiting time.
5. Test the value of the LVISF.LVISF bit to confirm that the voltage currently being supplied is above the detection level.
6. In the interrupt controller, clear the interrupt request flag for INTLVI.
7. Also in the interrupt controller, release masking of INTLVI.
8. On generation of the interrupt (INTLVI), test the value of the LVISF.LVISF bit to confirm the state of the power-supply voltage.

<Stopping LVI operation>

Set the LVICNT.LVICNT bit to 0.

- Caution 1. When an INTLVI is generated, test the value of the LVISF.LVISF bit to confirm the state of the voltage currently being supplied.
- Caution 2. To change the detection voltage, first stop the module and then set the voltage by following the same procedure as that for starting LVI operation.

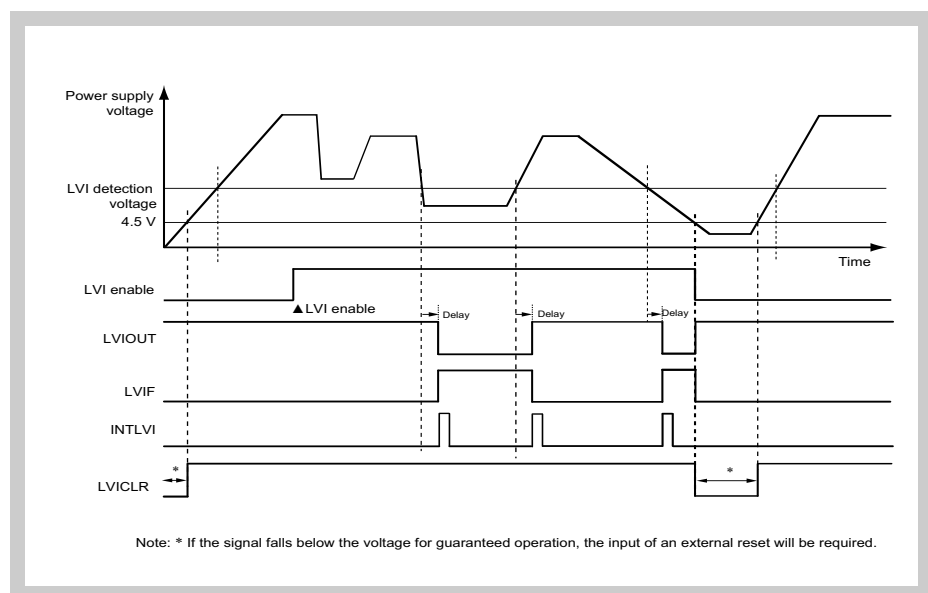

Figure 8-7 Example of LVI Operation (when the LVICNT.LVIMD Bit = 0)

8.4.3 Overview of POF/LVI Registers

Table 8-10 List of POF/LVI Registers

Register Name	Symbol	Address
Power-on flag control registers		
Power-on flag register	POF	FFFF FC00 _H
Power-on flag clear register	POFC	FFFF FC04 _H
Power-on flag set register	POFS	FFFF FC08 _H
LVI control registers		
LVI status flag register	LVISF	FFFF FC10 _H
LVI control register	LVICNT	FF45 0020 _H

8.4.4 Details of POF / LVI Control Registers

(1) POF - Power-on Flag Register

This register is used to confirm the state of the power-supply voltage for the internal regulator (VDD).

When the voltage has fallen below the detection voltage, the POF bit is set to 1 (i.e. initialized).

Access This register can be read in 8-bit units.

Address FFFF FC00_H

Initial value 01_H

7	6	5	4	3	2	1	0
0	0	0	0	0	0	0	POF
R	R	R	R	R	R	R	R

Table 8-11 POF Register Contents

Bit Position	Bit Name	Function
0	POF	This bit indicates the state of detection for the power-on flag. 0: Voltage VDD is above the detection voltage. 1: Voltage VDD is below the detection voltage (a low voltage from the power-supply for the internal regulator has been detected).

(2) POFC - Power-on Flag Clear Register

This register is used to clear the POF bit in the POF register to 0.

Access This register can be written in 8-bit units.

When read, the value returned is 00_H.

Address FFFF FC04_H

Initial value 00_H

7	6	5	4	3	2	1	0
0	0	0	0	0	0	0	POFC
R	R	R	R	R	R	R	W

Table 8-12 POFC Register Contents

Bit Position	Bit Name	Function
0	POFC	This bit controls clearing of the power-on flag register (the POF.POF bit). Writing 1 to the POFC bit causes clearing of the POF bit to 0. 0: No effect 1: The POF bit is cleared to 0.

(3) POFS - Power-on Flag Set Register

This register is used to set the POF bit in the POF register to 1.

Access This register can be written in 8-bit units.

When read, the value returned is 00_H.

Address FFFF FC08_H

Initial value 00_H

7	6	5	4	3	2	1	0
0	0	0	0	0	0	0	POFS
R	R	R	R	R	R	R	W

Table 8-13 POFS Register Contents

Bit Position	Bit Name	Function
0	POFS	Writing 1 to the POFS bit causes setting of the POF bit to 1. 0: No effect 1: The POF bit is set to 1.

(4) LVICNT - LVI Control Register

This register is used to set the operating mode for the LVI.

Once this register is set with the LVIMD and LVICNT bits set to 1, further changes to the setting are prohibited until the generation of a reset signal by various reset.

Access This register can be read/written in 8-bit units.

Address FF45 0020_H

Initial value 00_H

This register is initialized by a reset generated by a source other than the LVI.

7	6	5	4	3	2	1	0
LVIMD	0	0	0	0	0	LVICNT1	LVICNT0
R/W	R	R	R	R	R	R/W	R/W

Table 8-14 LVICNT Register Contents

Bit Position	Bit Name	Function															
7	LVIMD	This bit specifies the output signal in response to the LVI detecting an abnormal voltage. 0: The output is an interrupt signal (INTLVI). 1: The output is a reset signal (LVIRES).															
1,0	LVICNT1, LVICNT0	These bits enables/disables voltage detection by the LVI. <table border="1" data-bbox="842 546 1385 891"> <thead> <tr> <th>LVICNT1</th> <th>LVICNT0</th> <th>Function</th> </tr> </thead> <tbody> <tr> <td>0</td> <td>0</td> <td>Voltage detection by the LVI is disabled.</td> </tr> <tr> <td>0</td> <td>1</td> <td>Voltage detection by the LVI is enabled. The detection voltage is 4.6 ± 0.1 V.</td> </tr> <tr> <td>1</td> <td>0</td> <td>Voltage detection by the LVI is enabled. The detection voltage is 4.3 ± 0.1 V.</td> </tr> <tr> <td>1</td> <td>1</td> <td>Voltage detection by the LVI is enabled. The detection voltage is 3.1 ± 0.1 V.</td> </tr> </tbody> </table>	LVICNT1	LVICNT0	Function	0	0	Voltage detection by the LVI is disabled.	0	1	Voltage detection by the LVI is enabled. The detection voltage is 4.6 ± 0.1 V.	1	0	Voltage detection by the LVI is enabled. The detection voltage is 4.3 ± 0.1 V.	1	1	Voltage detection by the LVI is enabled. The detection voltage is 3.1 ± 0.1 V.
LVICNT1	LVICNT0	Function															
0	0	Voltage detection by the LVI is disabled.															
0	1	Voltage detection by the LVI is enabled. The detection voltage is 4.6 ± 0.1 V.															
1	0	Voltage detection by the LVI is enabled. The detection voltage is 4.3 ± 0.1 V.															
1	1	Voltage detection by the LVI is enabled. The detection voltage is 3.1 ± 0.1 V.															

(5) LVISF - LVI Status Flag Register

This register indicates the current state of detection by the LVI.

Access This register can be read in 8-bit units.

Address FFFF FC10_H

Initial value 00_H

7	6	5	4	3	2	1	0
0	0	0	0	0	0	0	LVISF
R	R	R	R	R	R	R	R

Table 8-15 LVISF Register Contents

Bit Position	Bit Name	Function
0	LVISF	This is the LVI detection flag and indicates the current state of detection. 0: The power-supply voltage for the internal regulator (VDD) is not low (or the LVI is not operating). 1: The power-supply voltage for the internal regulator (VDD) is low.

Section 9 Safety Functions

This section describes an overview of the safety functions.

The safety functions are as follows.

- Peripheral bus access error detection
- Memory access protection
- Self-diagnostic BIST
- ECC

9.1 Peripheral Bus Access Error Detection

This product incorporates a detector for errors in peripheral bus access.

This is capable of detecting errors in the form of

- access to undefined areas, and
- access timeout.

9.2 Memory Access Protection

This product incorporates memory-access protection functions.

- CPU core protection
 - Memory protection (MPU)
 - Peripheral protection (PPU)

9.2.1 Memory Access Protection

CPU core protection can be applied to memory areas and the address spaces specified in peripheral function registers. Rights to access can be assigned in accord with the state of software (for example, to set up a distinction between rights to access by the application program and drivers on the one hand and the operating system on the other).

For details, refer to the V850E2M Architecture Manual (R01US0001E).

9.3 Registers Related to the Peripheral I/O Bus

Registers related to the peripheral I/O bus are described in this section.

9.3.1 Overview of Registers Related to the Peripheral I/O Bus

Table 9-1 List of Registers Related to the Peripheral I/O Bus

Register Name	Symbol	Address
Peripheral I/O bus PSELG control register	APC	FF45 4000 _H
Peripheral I/O bus PSELG error status register	APES	FF45 4004 _H
Peripheral I/O bus PSELG error status clear register	APEC	FF45 4008 _H
Peripheral I/O bus PSELG error address storage register	APAM	FF45 400C _H
Peripheral I/O bus maximum access time set register	MATS	FF45 4010 _H

9.3.2 Details of Registers Related to the Peripheral I/O Bus

(1) APC - Peripheral I/O Bus PSELG Control Register

This register is used to specify several forms of checking for errors in access over the peripheral I/O bus.

Access This register can be read/written in 8-bit units.

Address FF45 4000_H

Initial value 00_H

This register is initialized by a reset from any source.

7	6	5	4	3	2	1	0
0	0	0	0	0	UAA	0	ATO
R	R	R	R	R	R/W	R	R/W

Table 9-2 APC Register Contents

Bit Position	Bit Name	Function
2	UAA	0: Checking for access to undefined areas does not proceed. 1: Checking for access to undefined areas proceeds. Undefined area is the area which does not belong to the peripheral I/O area.
0	ATO	0: Checking for access timeout does not proceed. 1: Checking for access timeout proceeds. This source flag is set when the time taken for access to the peripheral I/O bus exceeds the maximum access time specified in the MATS register.

(2) APES - Peripheral I/O Bus PSELG Error Status Register

This register contains error flags generated during the peripheral I/O bus access.

Access This register can be read in 8-bit units.

Address FF45 4004_H

Initial value 00_H

This register is initialized by a reset from any source or by writing to the APEC register.

7	6	5	4	3	2	1	0
0	0	0	0	0	UAA	0	ATO
R	R	R	R	R	R	R	R

Table 9-3 Contents of the APES Register

Bit Position	Bit Name	Function
2	UAA	0: An undefined-area-access error has not been generated. 1: An undefined-area-access error has been generated.
0	ATO	0: An access-timeout error has not been generated. 1: An access-timeout error has been generated.

Caution Once any of the ATO and UAA bits in this register is set to 1, it remains so until it is cleared by writing to the APEC register or by a reset.

(3) APEC - Peripheral I/O Bus PSELG Error Status Clear Register

This register is used to clear the several error flags which may be generated by access over the peripheral I/O bus.

Access This register can be written in 8-bit units.

When read, the value returned is 00_H.

Address FF45 4008_H

Initial value 00_H

This register is initialized by a reset from any source.

7	6	5	4	3	2	1	0
0	0	0	0	0	UAA	0	ATO
R	R	R	R	R	R/W	R	R/W

Table 9-4 Contents of the APEC Register

Bit Position	Bit Name	Function
2	UAA	0: The undefined-area-access error source flag in the APES register is not cleared. 1: The undefined-area-access error source flag in the APES register is cleared.
0	ATO	0: The access-timeout error source flag in the APES register is not cleared. 1: The access-timeout error source flag in the APES register is cleared.

(4) APAM - Peripheral I/O Bus PSELG Error Address Store Register

This register holds the address where access over the peripheral I/O bus led to any of the several errors.

In cases where multiple errors are generated, this register holds the address of the most recent error.

Access This register can be read in 32-bit units.

Address FF45 400C_H

Initial value FF00 0000_H

This register is initialized by a reset from any source.

31	30	29	28	27	26	25	24	23	22	21	20	19	18	17	16
1	1	1	1	1	1	1	1	A23	A22	A21	A20	A19	A18	A17	A16
R	R	R	R	R	R	R	R	R	R	R	R	R	R	R	R
15	14	13	12	11	10	9	8	7	6	5	4	3	2	1	0
A15	A14	A13	A12	A11	A10	A9	A8	A7	A6	A5	A4	A3	A2	A1	A0
R	R	R	R	R	R	R	R	R	R	R	R	R	R	R	R

Table 9-5 Contents of the APAM Register

Bit Position	Bit Name	Function
23 to 0	A[23:0]	These bits hold the address of the most recent error generated due to attempted access.

Caution Since this register holds the address of the most recent error, the stored address might not be that corresponding to the source which led to setting of an error status bit (APES.ATO and APES.UAA) to 1.

(5) MATS - Peripheral I/O Bus Maximum Access Time Set Register

This register is used to prevent blocking of access to the peripheral I/O bus by specifying the maximum bus access time (timeout time). Access over the peripheral I/O bus is forcibly ended when the time taken exceeds the time specified here. At this time, the access-timeout error flag (ATO) in the APES register is also set to 1.

Access This register can be read/written in 8-bit units.

Address FF45 4010_H

Initial value 00_H

This register is initialized by a reset from any source.

7	6	5	4	3	2	1	0
0	0	0	0	MATS3	MATS2	MATS1	MATS0
R	R	R	R	R/W	R/W	R/W	R/W

Table 9-6 MATS Register Contents

Bit Position	Bit Name	Function																																																		
3 to 0	MATS[3:0]	The available settings for maximum bus access time are listed below.																																																		
		<table border="1"> <thead> <tr> <th>MATS3</th> <th>MATS2</th> <th>MATS1</th> <th>MATS0</th> <th>Access Time</th> </tr> </thead> <tbody> <tr> <td>0</td> <td>0</td> <td>0</td> <td>0</td> <td>2⁹/PCLK</td> </tr> <tr> <td>0</td> <td>0</td> <td>0</td> <td>1</td> <td>2¹⁰/PCLK</td> </tr> <tr> <td>0</td> <td>0</td> <td>1</td> <td>0</td> <td>2¹¹/PCLK</td> </tr> <tr> <td>0</td> <td>0</td> <td>1</td> <td>1</td> <td>2¹²/PCLK</td> </tr> <tr> <td>0</td> <td>1</td> <td>0</td> <td>0</td> <td>2¹³/PCLK</td> </tr> <tr> <td>0</td> <td>1</td> <td>0</td> <td>1</td> <td>2¹⁴/PCLK</td> </tr> <tr> <td>0</td> <td>1</td> <td>1</td> <td>0</td> <td>2¹⁵/PCLK</td> </tr> <tr> <td>0</td> <td>1</td> <td>1</td> <td>1</td> <td>2¹⁶/PCLK</td> </tr> <tr> <td colspan="4">Other than above</td> <td>Setting prohibited</td> </tr> </tbody> </table>	MATS3	MATS2	MATS1	MATS0	Access Time	0	0	0	0	2 ⁹ /PCLK	0	0	0	1	2 ¹⁰ /PCLK	0	0	1	0	2 ¹¹ /PCLK	0	0	1	1	2 ¹² /PCLK	0	1	0	0	2 ¹³ /PCLK	0	1	0	1	2 ¹⁴ /PCLK	0	1	1	0	2 ¹⁵ /PCLK	0	1	1	1	2 ¹⁶ /PCLK	Other than above				Setting prohibited
MATS3	MATS2	MATS1	MATS0	Access Time																																																
0	0	0	0	2 ⁹ /PCLK																																																
0	0	0	1	2 ¹⁰ /PCLK																																																
0	0	1	0	2 ¹¹ /PCLK																																																
0	0	1	1	2 ¹² /PCLK																																																
0	1	0	0	2 ¹³ /PCLK																																																
0	1	0	1	2 ¹⁴ /PCLK																																																
0	1	1	0	2 ¹⁵ /PCLK																																																
0	1	1	1	2 ¹⁶ /PCLK																																																
Other than above				Setting prohibited																																																

9.4 Overview of Self-Diagnostic BIST

This section contains a general description of the self-diagnostic BIST.

Caution The registers listed below are beyond the scope of self-diagnostic BIST. Accordingly, except in the case of BSEQ0STRHBT and BSEQ0CTL, software must run self-diagnosis for these registers (by reading from and writing to the register or setting and clearing its bits).

Although setting and clearing of the bits in BSEQ0STRHBT is not possible, self diagnosis can take the form of checking the difference between master and checker bits in this register. For details, refer to Section 9.6.2

(6)BSEQ0STRHBT - Self-Diagnostic BIST Status Register.

BSEQ0CTL is a majority circuit of BSEQ0CTLA-C.

- POF (power on flag register)
 - RESF (reset source flag register)
 - SGAMESSTR0-1 (error source status registers 0 and 1, master)
 - SGACESSTR0-1 (error source status registers 0 and 1, checker)
 - BSEQ0STRHBT (self-diagnostic BIST status register)
 - BRAMDAT3-0 (backup RAM3-0 registers)
 - BSEQ0CTL (self-diagnostic BIST control register)
 - BSEQ0CTLA-C (self-diagnostic BIST control registers A to C)
 - LRAMSTBYCTL (on-chip RAM resumption–standby control register)
-

9.4.1 Self-Diagnostic BIST Skip Function

This product contains a facility for software to select skipping of the self-diagnostic BIST. Skipping the self-diagnostic BIST shortens the time to boot up from a reset when the power is on.

Caution If a pin reset coincides with RAM access, the value in RAM may be undefined after the reset. Accordingly, stop DMA transfer and place the controller in halted mode before input of the pin-reset signal.

9.4.2 Output of a Toggled Signal during Execution of Self-Diagnostic BIST

A Toggled signal can be output while self-diagnostic BIST is executed. This function can be used, for example, to clear the counter of the external watch dog timer. The pin (TGLOUT) used for output of the toggled signal is P8_0, and the setting of the OPBT0.FOP23 bit selects the initial state of the pin.

The P8_0/TGLOUT pin is in the Hi-Z state until the value for the OPBT0 is fixed from within the reset to flash reset sequence. Changing the setting in the TGLOUTOE register after Self-Diagnostic BIST allows the use of this facility as well as one of the other pin functions.

Table 9-7 Selecting the Function of the P8_0/TGLOUT Pin

OPBT0.FOP23	Selected Function
0	The toggled signal is output from P8_0
1	The toggled signal is not output from P8_0 (port/control mode is selected by the port register)

Table 9-8 Selecting the Cycle of Toggling

OPBT0.FOP22	Selected Cycle of Toggling
0	6.55 ms
1	13.10 ms

- When FOP23 = 0**
- After release from the reset state, TGLOUT mode is selected and a toggled signal is output with the cycle selected by FOP22 (duty cycle: 50%)
 - The TGLOUT pin will be at the low level after Self-Diagnostic BIST.

Note The toggled output from the TGLOUT pin does not always end at the same time as the completion of Self-Diagnostic BIST. The output on the TGLOUT pin is fixed to the low level once it is toggled to the low level after Self-Diagnostic BIST is completed. Check the TGLOUTOE.TGLOUTSTS bit to see whether toggled output on the TGLOUT pin has stopped.

- Follow the procedure below when changing the function of the TGLOUT pin to port mode after the CPU has started executing instructions.
- After the CPU has started executing instructions, set low-level output on bit P8_0. Then, set the PM8 register to enable output.
- Change the setting of the TGLOUTOE register from TGLOUT mode to port mode.
- Change the setting of the PMC8 register to select control mode.
- Output a toggled signal by setting TAUB0 channel 15 or OST1 timer output (the other functions multiplexed with P8_0).

- When FOP23 = 1** After the CPU has started executing instructions, the operation is in port/control mode and the pin remains in the Hi-Z state until the port register is set.

- Caution
- When FOP23 = 0, an oscillation stabilization time is inserted after an LVI reset or CLM reset.
 - The value of FOP23 determines the function of the P8_0/TGLOUT pin.

When FOP23 = 0 and HWBISTEN is set for skipping of Self-Diagnostic BIST, the pin continues to operate as TGLOUT after release from the reset state. In this case, the setting of the TGLOUTOE register needs to be changed from TGLOUT mode to port/control mode.

9.5 Self-Diagnostic BIST Related Registers

This section contains a general description of the registers related to Self-diagnostic BIST.

9.5.1 Overview of Registers Related to Self-Diagnostic BIST

Table 9-9 List of Registers Related to Self-Diagnostic BIST

Register Name	Symbol	Address
TGLOUT output control register	TGLOUTOE	FF42 003C _H
Self-Diagnostic BIST control register	BSEQ0CTL	FF42 0040 _H
Self-Diagnostic BIST control register A	BSEQ0CTLA	FF42 0044 _H
Self-Diagnostic BIST control register B	BSEQ0CTLB	FF42 0048 _H
Self-Diagnostic BIST control register C	BSEQ0CTLC	FF42 004C _H
BIST protection command register	BSEQ0TCRPCMD	FF83 B000 _H
BIST protection status register	BSEQ0TCRPESR	FF83 B004 _H
Self-Diagnostic BIST status register	BSEQ0STRHBT	FF83 B008 _H
Self-Diagnostic BIST status clear trigger register	BSEQ0STCHBT	FF83 B00C _H
SGA error pulse control register	SGAEPCTL	FF83 F020 _H
Backup RAM register 0	BRAMDAT0	FF83 F030 _H
Backup RAM register 1	BRAMDAT1	FF83 F034 _H
Backup RAM register 2	BRAMDAT2	FF83 F038 _H
Backup RAM register 3	BRAMDAT3	FF83 F03C _H
On-chip RAM resumption-standby control register	LRAMSTBYCTL	FF83 F080 _H

9.5.2 Details of Registers Related to Self-Diagnostic BIST

(1) TGLOUTOE—TGLOUT Output Control Register

This register controls the output from the P8_0/TGLOUT pin.

Output from the P8_0/TGLOUT pin is controlled by the setting of the TGLOUTOE0 bit. Port/control mode or TGLOUT mode is selected by the value.

This register is a specified-sequence register; that is, access for writing is only possible in a specified sequence.

Protection command register: CSCPCMD register

Protection status register: CSCPS register

Access This register can be read/written in 8-bit units.

Address FF42 003C_H

Initial value This depends on the setting of the FOP23 bit and the state of the TGLOUT pin.
This register is initialized by a reset from a source other than SWRES and BISTRES.

7	6	5	4	3	2	1	0
0	0	TGLOUT STS	TGLOUT LVL	0	0	0	TGLOUT OE0
R	R	R	R	R	R	R	R/W

Table 9-10 Contents of the TGLOUTOE Register

Bit Position	Bit Name	Function
5	TGLOUTSTS	Shows the state of output from TGLOUT 0: Output on TGLOUT is stopped. 1: The toggled signal is being output on TGLOUT.
4	TGLOUTLVL	Shows the level being output on the TGLOUT pin 0: The low level is being output on TGLOUT. 1: The high level is being output on TGLOUT.
0	TGLOUTOE0	Specifies the behavior of the P8_0 pin 0: P8_0 is being controlled by the port registers. 1: P8_0 is being used for TGLOUT. This bit is initialized by a reset from a source other than SWRES and BISTRES. However, it reflects the setting of the FOP23 bit after a flash-reset sequence. The initial value is 1 when FOP23 = 0. The initial value is 0 when FOP23 = 1. When the bit is initialized by SWRES or BISTRES, the value will remain unchanged from the previous value.

Caution After executing the instruction to write to this register, the completion of actual writing takes time. Ensure an interval of at least 6 cycles of the PLL input clock between consecutive rounds of writing to this register.
Example: When heapclk is running at 80 MHz, ensure an interval of at least 60 cycles of heapclk.

When the interval is shorter than this cycle, the register will not reflect the second value. For reading after writing, ensure an interval of 3 cycles of the PLL input clock.
Example: When heapclk is running at 80 MHz, ensure an interval of at least 30 cycles of heapclk.

(2) BSEQ0CTL - Self-Diagnostic BIST Control Register

This register is used to specify whether to skip or execute Self-diagnostic BIST. The register is not a target for Self-Diagnostic BIST and has a majority circuit. Since this register is write-protected, it is only accessible by following the designated sequence (regarding the designated sequence for the BSEQ0CTL register, refer to Section 8.2.10, Protection for Registers of the Reset Controller).

Protection command register: CSCPCMD register

Protection status register: CSCPS register

This registers are initialized when the power supply is turned on or the power supply voltage for the internal regulator (VDD) falls below the detection voltage indicated for the POF.

Access This register can be read/written in 8-bit units.

Address FF42 0040_H

Initial value 01_H

7	6	5	4	3	2	1	0
0	0	0	0	0	0	0	HWBISTEN
R	R	R	R	R	R	R	R/W

Table 9-11 Contents of the BSEQ0CTL Register

Bit Position	Bit Name	Function
0	HWBISTEN	This bit specifies execution or skipping of self-diagnostic BIST. 0: Self-Diagnostic BIST is skipped. 1: Self-Diagnostic BIST is executed.

Caution After writing to this register, read it to check that writing has been successful. Also check that the setting of the register matched the result of Self-Diagnostic BIST execution after release from the reset state. When the setting of the BSEQ0CTL and a reset source are in contention, the effectiveness of the setting of the BSEQ0CTL register is not guaranteed.

Caution After executing the instruction to write to this register, the completion of actual writing takes time. Ensure an interval of at least 6 cycles of the PLL input clock between consecutive rounds of writing to this register.
Example: When heapclk is running at 80 MHz, ensure an interval of at least 60 cycles of heapclk. When the interval is shorter than this cycle, the register will not reflect the second value. For reading after writing, ensure an interval of three cycles of the PLL input clock.
Example: When heapclk is running at 80 MHz, ensure an interval of at least 30 cycles of heapclk.

Majority method When writing to the address of a register having the majority structure, the same value is written to three majority registers. When reading, the value read is that for which at least two of the three registers have the same value. If the value in a register is inverted due to a malfunction, reading from the corresponding address corrects it.

(3) BSEQ0CTLx – Self-Diagnostic BIST Control Register x (x = A / B / C)

These registers are the individual registers used in majority decisions for the BSEQ0CTL register. The values held by the individual registers before the majority decision can be checked by reading registers A, B and C. The registers are initialized when the power supply is turned on or the power supply voltage for the internal regulator (VDD) falls below the detection voltage indicated for the POF.

Access This register can be read/written in 8-bit units.

Address BSEQ0CTLA: FF42 0044_H
 BSEQ0CTLB: FF42 0048_H
 BSEQ0CTLC: FF42 004C_H

Initial value 01_H

7	6	5	4	3	2	1	0
0	0	0	0	0	0	0	HWBISTEN
R	R	R	R	R	R	R	R/W

Table 9-12 Contents of the BSEQ0CTLx Register

Bit Position	Bit Name	Function
0	HWBISTEN	This bit specifies execution or skipping of self-diagnostic BIST. 0: Self-Diagnostic BIST is skipped. 1: Self-Diagnostic BIST is executed.

Caution After executing the instruction to write to this register, the completion of actual writing takes time. For details, see Section 9.5.2, (2), BSEQ0CTL - Self-Diagnostic BIST Control Register.

(4) BSEQ0TCRPCMD - BIST Protection Command Register

This register is a command register for the write-protected BIST registers.

Access This register can be written in 32-bit units.

Address FF83 B000_H

Initial value Undefined

31	30	29	28	27	26	25	24	23	22	21	20	19	18	17	16
W	W	W	W	W	W	W	W	W	W	W	W	W	W	W	W
15	14	13	12	11	10	9	8	7	6	5	4	3	2	1	0
W	W	W	W	W	W	W	W	W	W	W	W	W	W	W	W

Table 9-13 BSEQ0TCRPCMD Register Contents

Bit Position	Bit Name	Function
31 to 0		Write enable command for the write-protected BIST registers

(5) BSEQ0TCRPESR - BIST Protection Status Register

This register indicates the state in the sequence of protection executed by the BSEQ0TCRPCMD register.

Access This register can be read in 32-bit units.

Address FF83 B004_H

Initial value 0000 0000_H

This register is initialized by a reset from any source.

31	30	29	28	27	26	25	24	23	22	21	20	19	18	17	16
0	0	0	0	0	0	0	0	0	0	0	0	0	0	0	0
R	R	R	R	R	R	R	R	R	R	R	R	R	R	R	R
15	14	13	12	11	10	9	8	7	6	5	4	3	2	1	0
0	0	0	0	0	0	0	0	0	0	0	0	0	0	0	PESR0
R	R	R	R	R	R	R	R	R	R	R	R	R	R	R	R

Table 9-14 BSEQ0TCRPESR Register Contents

Bit Position	Bit Name	Function
0	PESR0	0: The generation of a protection error is not detected by protected-write-sequence error monitoring. 1: The generation of a protection error is detected by protected-write-sequence error monitoring.

(6) BSEQ0STRHBT - Self-Diagnostic BIST Status Register

This register indicates the state of self-diagnostic BIST.

Access This register can be read in 32-bit units.

Address FF83 B008_H

Initial value 0000 FF00_H

This register is initialized by a reset from any source.

31	30	29	28	27	26	25	24	23	22	21	20	19	18	17	16
BCE	MPE	CPE	0	0	0	0	0	0	0	0	0	0	0	0	0
R	R	R	R	R	R	R	R	R	R	R	R	R	R	R	R
15	14	13	12	11	10	9	8	7	6	5	4	3	2	1	0
1	HWBS 14	HWBS 13	HWBS 12	1	HWBS 10	HWBS 9	HWBS 8	0	HWBS 6	HWBS 5	HWBS 4	0	HWBS 2	HWBS 1	HWBS 0
R	R	R	R	R	R	R	R	R	R	R	R	R	R	R	R

Table 9-15 Contents of the BSEQ0STRHBT Register (1/2)

Bit Position	Bit Name	Function																					
31	BCE	0: BIST sequencer comparison errors are not generated. 1: BIST sequencer comparison errors are generated.																					
30	MPE	0: Self-diagnostic BIST code-parity errors are not generated (on the master side). 1: Self-diagnostic BIST code-parity errors are generated (on the master side).																					
29	CPE	0: Self-diagnostic BIST code-parity errors are not generated (on the checker side). 1: Self-diagnostic BIST code-parity errors are generated (on the checker side).																					
15 to 8	HWBS[15:8]	<p>The state of self-diagnostic BIST by the checker's BIST sequencer</p> <p>0: The sequence of self-diagnostic BIST by the checker ended normally. 1: The sequence of self-diagnostic BIST by the checker ended abnormally, did not end, or has not started.</p> <table border="1"> <thead> <tr> <th>HWBS Bit</th> <th>Memory /Logic</th> <th>Test Group</th> </tr> </thead> <tbody> <tr> <td>15</td> <td rowspan="4">Memory</td> <td>Fixed to 1</td> </tr> <tr> <td>14</td> <td>This bit reflects the result of memory BIST execution. *1</td> </tr> <tr> <td>13</td> <td>This bit reflects the result of memory BIST execution. *1</td> </tr> <tr> <td>12</td> <td>This bit reflects the result of memory BIST execution. *1</td> </tr> <tr> <td>11</td> <td rowspan="4">Logic</td> <td>Fixed to 1</td> </tr> <tr> <td>10</td> <td>This bit reflects the result of logic BIST execution. *2</td> </tr> <tr> <td>9</td> <td>This bit reflects the result of logic BIST execution. *2</td> </tr> <tr> <td>8</td> <td>This bit reflects the result of logic BIST execution. *2</td> </tr> </tbody> </table>	HWBS Bit	Memory /Logic	Test Group	15	Memory	Fixed to 1	14	This bit reflects the result of memory BIST execution. *1	13	This bit reflects the result of memory BIST execution. *1	12	This bit reflects the result of memory BIST execution. *1	11	Logic	Fixed to 1	10	This bit reflects the result of logic BIST execution. *2	9	This bit reflects the result of logic BIST execution. *2	8	This bit reflects the result of logic BIST execution. *2
HWBS Bit	Memory /Logic	Test Group																					
15	Memory	Fixed to 1																					
14		This bit reflects the result of memory BIST execution. *1																					
13		This bit reflects the result of memory BIST execution. *1																					
12		This bit reflects the result of memory BIST execution. *1																					
11	Logic	Fixed to 1																					
10		This bit reflects the result of logic BIST execution. *2																					
9		This bit reflects the result of logic BIST execution. *2																					
8		This bit reflects the result of logic BIST execution. *2																					

Table 9-15 Contents of the BSEQ0STRHBT Registe (2/2)

Bit Position	Bit Name	Function																					
7 to 0	HWBS[7:0]	<p>The state of self-diagnostic BIST by the master's BIST sequencer</p> <p>0: The sequence of self-diagnostic BIST by the master ended abnormally, did not end, or has not started.</p> <p>1: The sequence of self-diagnostic BIST by the master ended normally.</p> <table border="1"> <thead> <tr> <th>HWBS Bit</th> <th>Memory /Logic</th> <th>Test Group</th> </tr> </thead> <tbody> <tr> <td>7</td> <td rowspan="4">Memory</td> <td>Fixed to 0</td> </tr> <tr> <td>6</td> <td>This bit reflects the result of memory BIST execution. ^{*1}</td> </tr> <tr> <td>5</td> <td>This bit reflects the result of memory BIST execution. ^{*1}</td> </tr> <tr> <td>4</td> <td>This bit reflects the result of memory BIST execution. ^{*1}</td> </tr> <tr> <td>3</td> <td rowspan="4">Logic</td> <td>Fixed to 0</td> </tr> <tr> <td>2</td> <td>This bit reflects the result of logic BIST execution. ^{*2}</td> </tr> <tr> <td>1</td> <td>This bit reflects the result of logic BIST execution. ^{*2}</td> </tr> <tr> <td>0</td> <td>This bit reflects the result of logic BIST execution. ^{*2}</td> </tr> </tbody> </table>	HWBS Bit	Memory /Logic	Test Group	7	Memory	Fixed to 0	6	This bit reflects the result of memory BIST execution. ^{*1}	5	This bit reflects the result of memory BIST execution. ^{*1}	4	This bit reflects the result of memory BIST execution. ^{*1}	3	Logic	Fixed to 0	2	This bit reflects the result of logic BIST execution. ^{*2}	1	This bit reflects the result of logic BIST execution. ^{*2}	0	This bit reflects the result of logic BIST execution. ^{*2}
HWBS Bit	Memory /Logic	Test Group																					
7	Memory	Fixed to 0																					
6		This bit reflects the result of memory BIST execution. ^{*1}																					
5		This bit reflects the result of memory BIST execution. ^{*1}																					
4		This bit reflects the result of memory BIST execution. ^{*1}																					
3	Logic	Fixed to 0																					
2		This bit reflects the result of logic BIST execution. ^{*2}																					
1		This bit reflects the result of logic BIST execution. ^{*2}																					
0		This bit reflects the result of logic BIST execution. ^{*2}																					

Note 1. Memory BIST in this product does not differentiate between areas. That is, the result of self-diagnostic BIST is reflected in all of the corresponding bits in the same manner.

Note 2. Logic BIST in this product handles all logic as a single group. That is, the result of self-diagnostic BIST is reflected in all of the corresponding bits in the same manner.

(7) BSEQ0STCHBT - Self-Diagnostic BIST Status Clear Trigger Register

This register is used to clear error source flags in the BSEQ0STRHBT register. This register has a designated sequence, so only access in that sequence will be effective for writing. For details, see Section 9.5.3, Procedure for Setting the BSEQ0STCHBT Register.

Access This register can be written in 32-bit units.

Address FF83 B00C_H

Initial value 0000 0000_H

This register is initialized by a reset from any source.

31	30	29	28	27	26	25	24	23	22	21	20	19	18	17	16
CLHW BS31	CLHW BS30	CLHW BS29	0	0	0	0	0	0	0	0	0	0	0	0	0
W	W	W	W	W	W	W	W	W	W	W	W	W	W	W	W
15	14	13	12	11	10	9	8	7	6	5	4	3	2	1	0
0	CLHW BS14	CLHW BS13	CLHW BS12	0	CLHW BS10	CLHW BS9	CLHW BS8	0	CLHW BS6	CLHW BS5	CLHW BS4	0	CLHW BS2	CLHW BS1	CLHW BS0
W	W	W	W	W	W	W	W	W	W	W	W	W	W	W	W

Table 9-16 Contents of the BSEQ0STCHBT Register

Bit Position	Bit Name	Function
31	CLHWBS31	This bit clears the HWBS31 bit in the BSEQ0STRHBT register. 0: No effect (setting this bit to 0 does not affect the BSEQ0STRHBT register). 1: Bit HWBS31 is cleared
30	CLHWBS30	This bit clears the HWBS30 bit in the BSEQ0STRHBT register. 0: No effect (setting this bit to 0 does not affect the BSEQ0STRHBT register). 1: Bit HWBS30 is cleared
29	CLHWBS29	This bit clears the HWBS29 bit in the BSEQ0STRHBT register. 0: No effect (setting this bit to 0 does not affect the BSEQ0STRHBT register). 1: Bit HWBS29 is cleared
15 to 8	CLHWBS[15:8]	This bit sets the HWBS[15:8] bits in the BSEQ0STRHBT register. 0: No effect (setting this bit to 0 does not affect the BSEQ0STRHBT register). 1: Bits HWBS[15:8] are cleared
7 to 0	CLHWBS[7:0]	This bit sets the HWBS[7:0] bits in the BSEQ0STRHBT register. 0: No effect (setting this bit to 0 does not affect the BSEQ0STRHBT register). 1: Bits HWBS[7:0] are cleared

Caution When clearing the status flags, be sure to clear all required bits with a single access. (Write E000FFFF_H to the BSEQ0STCHBT register.)

(8) SGAEPCTL - SGA Error Pulse Control Register

This register is used to select the timer for dynamic-mode operation (for details, see Section 10.3.3, Operations for Error Output).

Access This register can be read/written in 8-bit units.

Address FF83 F020_H

Initial value 00_H

This register is initialized by a reset from any source.

7	6	5	4	3	2	1	0
0	0	0	0	0	0	0	SGATMSL
R	R	R	R	R	R	R	R/W

Table 9-17 Contents of the SGAEPCTL Register

Bit Position	Bit Name	Function
0	SGATMSL	This bit selects the source of the timer for input to the safety guardian. 0: TAUB0 channel15 1: OSTM1

(9) BRAMDATn (n = 0 to 3) - Back-up RAM Register

The contents of on-chip RAM are undefined after self-diagnostic BIST. Since this register may hold values before the execution of self-diagnostic BIST, save the data beforehand. This 128-bit register is composed of four registers.

Access This register can be read/written in 32-bit units.

Address FF83 F030_H (BRAMDAT0)

FF83 F034_H (BRAMDAT1)

FF83 F038_H (BRAMDAT2)

FF83 F03C_H (BRAMDAT3)

Initial value Undefined

127-96	95-64	63-32	31-0
BRAMDAT3	BRAMDAT2	BRAMDAT1	BRAMDAT0
R/W	R/W	R/W	R/W

(10) LRAMSTBYCTL – On-Chip RAM Resumption–Standby Control Register

This register prohibits access to and protects the on-chip RAM. This register can be set so that the data in on-chip RAM are retained after a reset.

This register is initialized when the power supply is turned on or the power supply voltage for the internal regulator (VDD) falls below the detection voltage indicated for the POF.

Access This register can be read/written in 8-bit units.

Address FF83 F080_H

Initial value 00_H

7	6	5	4	3	2	1	0
0	0	0	0	0	0	0	LRAM STBYCTL0
R	R	R	R	R	R	R	R/W

Table 9-18 Contents of the LRAMSTBYCTL Register

Bit Position	Bit Name	Function
0	LRAMSTBYCTL0	Enables/disables access to the on-chip RAM 0: The on-chip RAM operates normally. 1: Access to the on-chip RAM is disabled (RAM is protected).

Caution Write to the register while access to the on-chip RAM is not in progress. Operation is not guaranteed when a changeover is attempted during access to the on-chip RAM. This register is initialized when the power supply is turned on or the power supply voltage for the internal regulator (VDD) falls below the detection voltage indicated for the POF. Therefore, if the LRAMSTBYCTL0 bit is set to 1, the state of the on-chip RAM is retained after release from the reset state. Change to normal mode before access to the on-chip RAM. This function does not support data retention if the voltage goes out of the guaranteed range. Executing self-diagnosis (BIST) leads to the execution of memory BIST regardless of the setting of the LRAMSTBYCTL register. In such cases, the values in on-chip RAM are not guaranteed.

9.5.3 Procedure for Setting the BSEQ0STCHBT Register

The BSEQ0STCHBT register is write-protected, and is thus only writable by following the designated sequence below.

- Step 1: Write the designated value (000000A5_H) to the protection-command register (BSEQ0TCRPCMD).
- Step 2: Write the desired setting to the target write-protected register (BSEQ0STCHBT). (Writing is invalid in this step.)
- Step 3: Write the inverse of the desired setting to the target write-protected register (BSEQ0STCHBT). (Writing is invalid in this step.)
- Step 4: Again write the desired setting to the target write-protected register (BSEQ0STCHBT). (Writing is effective in this step.)

9.6 ECC Related Registers

This section describes the ECC related registers.

9.6.1 Overview of ECC Related Registers

Table 9-19 Contents of the ECC Related Registers

Register Name	Symbol	Address
Code flash ECC		
Code flash ECC error flag register	CECCER	FF43 2000 _H
Code flash ECC error flag clear register	CECCERC	FF43 2004 _H
Code flash ECC error correction address register	CECADR	FF43 2008 _H
Code flash ECC error detection address register	CEDADR	FF43 200C _H
On-chip RAM ECC		
On-chip RAM ECC error flag register	LECCER	FF46 8000 _H
On-chip RAM ECC error flag clear register	LECCERC	FF46 8004 _H
On-chip RAM ECC error correction address register	LECADR	FF46 8008 _H
On-chip RAM ECC error detection address register	LEDADR	FF46 800C _H
CAN RAM ECC		
CAN0 ECC0 control register	E6A0CTL	FF46 0000 _H
CAN1 ECC0 control register	E6A2CTL	FF46 0800 _H

Caution When an ECC error is generated from the contents or tag bits of the flash cache and flash cache tag, the error is notified but the error address is not retained.

9.6.2 Details of ECC Related Registers

(1) CECCER - Code Flash ECC Error Flag Register

The corresponding bit in this register is set when an ECC error is generated.

Access This register can be read in 8-bit units.

Address FF43 2000_H

Initial value 00_H

This register is initialized by a reset from any source.

7	6	5	4	3	2	1	0
0	0	0	0	0	0	CECCER0 EDFLG	CECCER0 ECFLG
R	R	R	R	R	R	R	R

Table 9-20 Contents of the CECCER Register

Bit Position	Bit Name	Function
1	CECCER0EDFLG	0: ECC uncorrectable error is not generated. 1: ECC uncorrectable error is generated.
0	CECCER0ECFLG	0: ECC correction does not occur. 1: ECC correction occurs.

(2) CECCERC - Code Flash ECC Error Flag Clear Register

This register is used to clear values set in the CECCER register. Specifically, writing 1 to an effective bit in this register clears the corresponding bit in the CECCER register.

Access This register can be read/written in 8-bit units.

When read, the value returned is always 00_H.

Address FF43 2004_H

Initial value 00_H

This register is initialized by a reset from any source.

7	6	5	4	3	2	1	0
0	0	0	0	0	0	CECCER 0EDCLR	CECCER 0ECCLR
R	R	R	R	R	R	R/W	R/W

Table 9-21 Contents of the CECCERC Register

Bit Position	Bit Name	Function
1	CECCER0EDCLR	This bit controls clearing of the code-flash ECC error flag (the CECCER.CECCER0EDFLG bit). 0: CECCER.CECCER0EDFLG is not cleared. 1: CECCER.CECCER0EDFLG is cleared.
0	CECCER0ECCLR	This bit controls clearing of the code-flash ECC error flag (the CECCER.CECCER0ECFLG bit). 0: CECCER.CECCER0ECFLG is not cleared. 1: CECCER.CECCER0ECFLG is cleared.

(3) CECADR - Code Flash ECC Error Correction Address Register

If ECC correction occurs, this register holds the corresponding address. If the CECCER.CECCER0ECFLG is 0, the stored address where the error was encountered is not changed until clearing of the CECCER0ECFLG.

Access This register can be read in 32-bit units.

Address FF43 2008_H

Initial value 0000 0000_H

This register is initialized by clearing the CECCER.CECCER0ECFLG bit or by a reset from any source.

31	30	29	28	27	26	25	24	23	22	21	20	19	18	17	16
0	0	0	0	0	0	0	0	0	0	CECADR0A[21:16]					
R	R	R	R	R	R	R	R	R	R	R	R	R	R	R	R
15	14	13	12	11	10	9	8	7	6	5	4	3	2	1	0
CECADR0A[15:4]												0	0	0	0
R	R	R	R	R	R	R	R	R	R	R	R	R	R	R	R

Table 9-22 Contents of the ECC Error Correction Address Register

Bit Position	Bit Name	Function
21 to 4	CECADR0A [21:4]	These bits hold the address where ECC correction was applied.

(4) CEDADR - Code Flash ECC Error Detection Address Register

When an ECC error is encountered, this register holds the corresponding address. If CECCER.CECCER0EDFLG is 0, the stored address where the error was encountered is not changed until clearing of CECCER0EDFLG.

Access This register can be read in 32-bit units.

Address FF43 200C_H

Initial value 0000 0000_H

This register is initialized by clearing the CECCER.CECCER0EDFLG bit or by a reset from any source.

31	30	29	28	27	26	25	24	23	22	21	20	19	18	17	16
0	0	0	0	0	0	0	0	0	0	CEDADR0A[21:16]					
R	R	R	R	R	R	R	R	R	R	R	R	R	R	R	R
15	14	13	12	11	10	9	8	7	6	5	4	3	2	1	0
CEDADR0A[15:4]												0	0	0	0
R	R	R	R	R	R	R	R	R	R	R	R	R	R	R	R

Table 9-23 Contents of the ECC Error Detection Address Register

Bit Position	Bit Name	Function
21 to 4	CEDADR0A [21:4]	These bits hold the address where the ECC error was encountered.

(5) LECCER - On-chip RAM ECC Error Flag Register

This register indicates the occurrence of ECC correctable and uncorrectable errors in the on-chip RAM.

Access This register can be read in 8-bit units.

Address FF46 8000_H

Initial value 00_H

This register is initialized by a reset from any source.

7	6	5	4	3	2	1	0
0	0	0	0	0	0	LECCER0 EDFLG	LECCER0 ECFLG
R	R	R	R	R	R	R	R

Table 9-24 Contents of the LECCER Register

Bit Position	Bit Name	Function
1	LECCER0EDFLG	0: ECC uncorrectable error is not generated in the on-chip RAM. 1: ECC uncorrectable error is generated in the on-chip RAM.
0	LECCER0ECFLG	0: ECC correction does not occur in the on-chip RAM. 1: ECC correction occurs in the on-chip RAM.

(6) LECCERC - On-chip RAM ECC Error Flag Clear Register

This register is used to clear values set in the LECCER register. Specifically, writing 1 to an effective bit in this register clears the corresponding bit in the LECCER register.

Access This register can be read/written in 8-bit units.

When read, the value returned is 00_H.

Address FF46 8004_H

Initial value 00_H

This register is initialized by a reset from any source.

7	6	5	4	3	2	1	0
0	0	0	0	0	0	LECCER0 EDCLR	LECCER0 ECCLR
R	R	R	R	R	R	R/W	R/W

Table 9-25 Contents of the LECCERC Register

Bit Position	Bit Name	Function
1	LECCER0EDCLR	This bit controls clearing of the on-chip RAM ECC error flag (the LECCER.LECCER0EDFLG bit). 0: LECCER.LECCER0EDFLG is not cleared. 1: LECCER.LECCER0EDFLG is cleared.
0	LECCER0ECCLR	This bit controls clearing of the on-chip RAM ECC error flag (the LECCER.LECCER0ECFLG bit). 0: LECCER.LECCER0ECFLG is not cleared. 1: LECCER.LECCER0ECFLG is cleared.

(7) LECADR - On-chip RAM Error Correction Address Register

When an ECC error is encountered in access to on-chip RAM, this register holds the corresponding address. If LECCER.LECCER0ECFLG is 0, the stored address where the error was encountered is not changed until clearing of LECCER0ECFLG.

Access This register can be read in 32-bit units.

Address FF46 8008_H

Initial value 0000 0000_H

This register is initialized by clearing the LECCER.LECCER0ECFLG bit or by a reset from any source.

31	30	29	28	27	26	25	24	23	22	21	20	19	18	17	16
0	0	0	0	0	0	0	0	0	0	0	LECADR0A[20:16]				
R	R	R	R	R	R	R	R	R	R	R	R	R	R	R	R
15	14	13	12	11	10	9	8	7	6	5	4	3	2	1	0
LECADR0A[15:2]													0	0	
R	R	R	R	R	R	R	R	R	R	R	R	R	R	R	R

Table 9-26 Contents of the On-chip RAM Error Correction Address Register

Bit Position	Bit Name	Function
20 to 2	LECADR0A [20:2]	These bits hold the address where ECC was applied to on-chip RAM.

(8) LEDADR - On-chip RAM ECC Error Detection Address Register

When an ECC error is encountered in access to on-chip RAM, this register holds the corresponding address. If LECCER.LECCER0EDFLG is 0, the stored address where the error was encountered is not changed until clearing of LECCER0EDFLG.

Access This register can be read in 32-bit units.

Address FF46 800C_H

Initial value 0000 0000_H

This register is initialized by clearing the LECCER.LECCER0EDFLG bit or by a reset from any source.

31	30	29	28	27	26	25	24	23	22	21	20	19	18	17	16
0	0	0	0	0	0	0	0	0	0	0	LEDADR0A[20:16]				
R	R	R	R	R	R	R	R	R	R	R	R	R	R	R	R
15	14	13	12	11	10	9	8	7	6	5	4	3	2	1	0
LEDADR0A[15:2]													0	0	
R	R	R	R	R	R	R	R	R	R	R	R	R	R	R	R

Table 9-27 Contents of the On-chip RAM ECC Error Detection Address Register

Bit Position	Bit Name	Function
20 to 2	LEDADR0A [20:2]	These bits hold the address where an ECC error was encountered in access to on-chip RAM.

(9) E6A0CTL - CAN0 ECC0 Control Register

When an ECC error is generated in the CAN RAM, the corresponding bit in this register is set to 1 or the current setting is cleared. Writing 1 to a bit in this register clears the bit.

Access This register can be read/written in 32-bit units.

The value read from E6A0CTL.E6A0CTLER2C is always 0.

Address FF46 0000_H (E6A0CTL)

Initial value Undefined

This register is initialized by a reset from any source.

31	30	29	28	27	26	25	24	23	22	21	20	19	18	17	16
0	0	0	0	0	0	0	0	0	0	0	0	0	0	0	0
R	R	R	R	R	R	R	R	R	R	R	R	R	R	R	R
15	14	13	12	11	10	9	8	7	6	5	4	3	2	1	0
0	0	0	0	0	E6A0 CTLE R2C	0	0	0	0	0	0	0	E6A0 CTLE CCER2	0/1	0/1
R	R	R	R	R	R/W	R	R	R	R	R	R	R	R	R	R

Table 9-28 Contents of the E6A0CTL Register

Bit Position	Bit Name	Function
10	E6A0CTLE R2C	0: The E6A0CTL.E6A0CTLECCER2 bits are not cleared. 1: The E6A0CTL.E6A0CTLECCER2 bits are cleared.
2	E6A0CTLE CCER2	0: An ECC error in the CAN RAM has not been generated. 1: An ECC error in the CAN RAM has been generated.

(10) E6A2CTL - CAN1 ECC0 Control Register

When an ECC error is generated in the CAN RAM, the corresponding bit in this register is set to 1 or the current setting is cleared. Writing 1 to a bit in this register clears the bit.

Access This register can be read/written in 32-bit units.

The value read from E6A2CTL.E6A2CTLER2C is always 0.

Address FF46 0800_H (E6A2CTL)

Initial value Undefined

This register is initialized by a reset from any source.

31	30	29	28	27	26	25	24	23	22	21	20	19	18	17	16
0	0	0	0	0	0	0	0	0	0	0	0	0	0	0	0
R	R	R	R	R	R	R	R	R	R	R	R	R	R	R	R
15	14	13	12	11	10	9	8	7	6	5	4	3	2	1	0
0	0	0	0	0	E6A2 CTLE R2C	0	0	0	0	0	0	0	E6A2 CTLE CCER2	0/1	0/1
R	R	R	R	R	R/W	R	R	R	R	R	R	R	R	R	R

Table 9-29 Contents of the E6A2CTL Register

Bit Position	Bit Name	Function
10	E6A2CTLE R2C	0: The E6A2CTL.E6A2CTLECCER2 bits are not cleared. 1: The E6A2CTL.E6A2CTLECCER2 bits are cleared.
2	E6A2CTLE CCER2	0: An ECC error in the CAN RAM has not been generated. 1: An ECC error in the CAN RAM has been generated.

9.7 Self-Diagnosis Method for a Compare Unit

Follow the procedure below to execute self-diagnosis of a comparison unit during operations. The behavior is not guaranteed in case of departure from the procedure described.

- Procedure 1**
1. After start-up, read the RESF register to check that a reset is not being generated by the safety guardian (hereinafter called the SGA).
 2. In the INTCFGB register, change INTCME (compare interrupt) from the NMI level to the EI level.
 3. In the SGAIRCFG0 register, mask the generation of the SGA reset ($\overline{\text{SGARES}}$) in response to a comparison unit error (SGATERRIN5).
 4. Set the ICSGACMEDIAG register to enable interrupts.
 5. Write 1 to the SGAPE1.SGAPE109 bit. The output signal corresponding to the SGAPE109 bit is only connected to the INTC terminal of the master CPU, so interrupts are only conveyed to the master CPU.
 6. Enable a reset in response to the compare unit error (SGATERRIN5) by the SGAIRCFG0 register in the interrupt routine of compare unit error.
 7. SGA reset ($\overline{\text{SGARES}}$) is generated (non-generation of the reset means a malfunction of the comparison unit). At this point, the INTCFGB register is initialized.
 8. After the chip is restarted, read the RESF register to check that an SGA reset ($\overline{\text{SGARES}}$) is being generated.
 9. Clear the flag set to indicate the comparison unit error (SGATERRIN5) in the error source status register of the SGA.
- Procedure 2**
1. After start-up, read the RESF register to check that a reset is not being generated by the SGA.
 2. In the INTCFGB register, change INTCME (compare interrupt) from the NMI level to the EI level.
 3. In the SGAIRCFG0 register, enable the generation of the SGA reset ($\overline{\text{SGARES}}$) in response to a comparison unit error (SGATERRIN5).
 4. Use the interrupt mask bit (ICSGACMEDIAG.MKSGACMEDIAG) to mask the interrupt corresponding to the SGAPE109 bit in the SGAPE1 register.
 5. Write 1 to the SGAPE1.SGAPE109 bit. The output signal corresponding to the SGAPE109 bit is only connected to the INTC terminal of the master CPU, so interrupts are only conveyed to the master CPU.
 6. Transfer the value of the ICSGACMEDIAG register to the RAM. The values read by the master CPU and the checker CPU will differ, and so will not match.
An SGA reset ($\overline{\text{SGARES}}$) is generated (non-generation of the reset means a malfunction of the compare unit). At this point, the INTCFGB register is initialized.
 7. After the chip is restarted, read the RESF register to check that an SGA reset ($\overline{\text{SGARES}}$) is being generated.
 8. Clear the flag set to indicate the comparison unit error (SGATERRIN5) in the error source status register of the SGA.

9.8 Resources Required for Initialization

9.8.1 On-chip RAM

Initial values in on-chip RAM are undefined, so reading it without initialization raises the possibility of an ECC error. Accordingly, we recommend initializing the whole on-chip RAM (with any desired values).

Caution After an uninitialized address is written to, if the same address is read following the write, an ECC error may occur.

9.8.2 Registers

Initial values for the registers listed below are undefined, so reading them without initialization raises the possibility of a CPU comparison error. Accordingly, we recommend initializing all of these registers (with any desired values).

When initializing the specified registers only according to the conditions, evaluate them enough before using.

Table 9-30 List of Registers to be Initialized (Program Registers)

Name	Function
r1	Assembler-reserved register
r2	Address- and data-variables register
r3	Stack pointer (SP)
r4	Global pointer (GP)
r5	Text pointer (TP)
r6 to r29	Address- and data-variables register
r30	Element pointer (EP)
r31	Link pointer (LP)

Caution In some cases these registers will be implicitly used by the C compiler, etc., so use the start-up routine to initialize these registers.

Table 9-31 List of Registers to be Initialized (System Registers)

Group Name	Bank Name	Number of System Register	Name	Function
CPU group	Base bank	0	EIPC	This register preserves the state on acceptance of an EI level exception.
		2	FEPC	This register preserves the state on acceptance of an FE level exception.
		11	SCCFG	Settings for SYSCAL operations
		12	SCBP	Base pointer for SYSCALL
		16	CTPC	This register preserves the state on execution of a CALLT instruction.
		20	CTBP	Base pointer for CALLT
		28*	EIWR	Working register for use with EI levels
		29*	FEWR	Working register for use with FE levels
CPU core protection group	CPU core protection violations	1	VSTID	Task identifier for system-register protection violations
		2	VSADR	Address of system-register protection violations
		5	VMTID	Task identifier for memory-protection violations
		6	VMADR	Address of memory-protection violations
		24	MCA	Address for checking of memory-protection settings
		25	MCS	Size for checking of memory-protection settings

Note: * The above system registers are always accessible regardless of the state of the BSELL register.

Table 9-32 List of Registers to be Initialized (CPU core Protection Related Registers)

Address	Name	Function
FFFF5110 _H	VPNECR	Peripheral device protection NT state violation cause register
FFFF5110 _H	VPNECRL	Peripheral device protection NT state violation cause register L
FFFF5110 _H	VPNECRLH	Peripheral device protection NT state violation cause register LH
FFFF5111 _H	VPNECRLH	Peripheral device protection NT state violation cause register LH
FFFF5114 _H	VPNADR	Peripheral device protection NT state violation address register
FFFF5114 _H	VPNADRRL	Peripheral device protection NT state violation address register L
FFFF5114 _H	VPNADRLL	Peripheral device protection NT state violation address register LL
FFFF5115 _H	VPNADRLLH	Peripheral device protection NT state violation address register LH
FFFF5116 _H	VPNADRHL	Peripheral device protection NT state violation address register HL
FFFF5116 _H	VPNADRHL	Peripheral device protection NT state violation address register HL
FFFF5117 _H	VPNADRHH	Peripheral device protection NT state violation address register HH
FFFF5118 _H	VPNTID	Peripheral device protection NT state violation task ID register
FFFF5118 _H	VPNTIDL	Peripheral device protection NT state violation task ID register L
FFFF5118 _H	VPNTIDLL	Peripheral device protection NT state violation task ID register LL
FFFF5119 _H	VPNTIDLH	Peripheral device protection NT state violation task ID register LH
FFFF511A _H	VPNTIDH	Peripheral device protection NT state violation task ID register H
FFFF511A _H	VPNTIDHL	Peripheral device protection NT state violation task ID register HL
FFFF511B _H	VPNTIDHH	Peripheral device protection NT state violation task ID register HH
FFFF5120 _H	VPTECR	Peripheral device protection T state violation cause register
FFFF5120 _H	VPTECRL	Peripheral device protection T state violation cause register L
FFFF5120 _H	VPTECRLH	Peripheral device protection T state violation cause register LH
FFFF5121 _H	VPTECRLH	Peripheral device protection T state violation cause register LH
FFFF5124 _H	VPTADR	Peripheral device protection T state violation address register
FFFF5124 _H	VPTADRRL	Peripheral device protection T state violation address register L
FFFF5124 _H	VPTADRLL	Peripheral device protection T state violation address register LL
FFFF5125 _H	VPTADRLLH	Peripheral device protection T state violation address register LH
FFFF5126 _H	VPTADRHL	Peripheral device protection T state violation address register HL
FFFF5126 _H	VPTADRHL	Peripheral device protection T state violation address register HL
FFFF5127 _H	VPTADRHH	Peripheral device protection T state violation address register HH
FFFF5128 _H	VPTTID	Peripheral device protection T state violation task ID register
FFFF5128 _H	VPTTIDL	Peripheral device protection T state violation task ID register L
FFFF5128 _H	VPTTIDLL	Peripheral device protection T state violation task ID register LL
FFFF5129 _H	VPTTIDLH	Peripheral device protection T state violation task ID register LH
FFFF512A _H	VPTTIDH	Peripheral device protection T state violation task ID register H
FFFF512A _H	VPTTIDHL	Peripheral device protection T state violation task ID register HL
FFFF512B _H	VPTTIDHH	Peripheral device protection T state violation task ID register HH

Table 9-33 List of Registers to be Initialized (Registers Related to the Timing Supervisor)

Address	Name	Function
FFFF5024 _H	TSCCNT0	Count value of timing supervision counter n register 0
FFFF5028 _H	TSCCMP0	Comparison value of timing supervision counter n register 0
FFFF502C _H	TSCRLD0	Reload value of timing supervision counter n register 0
FFFF5034 _H	TSCCNT1	Count value of timing supervision counter n register 1
FFFF5038 _H	TSCCMP1	Comparison value of timing supervision counter n register 1
FFFF503C _H	TSCRLD1	Reload value of timing supervision counter n register 1
FFFF5044 _H	TSCCNT2	Count value of timing supervision counter n register 2
FFFF5048 _H	TSCCMP2	Comparison value of timing supervision counter n register 2
FFFF504C _H	TSCRLD2	Reload value of timing supervision counter n register 2
FFFF5054 _H	TSCCNT3	Count value of timing supervision counter n register 3
FFFF5058 _H	TSCCMP3	Comparison value of timing supervision counter n register 3
FFFF505C _H	TSCRLD3	Reload value of timing supervision counter n register 3
FFFF5064 _H	TSCCNT4	Count value of timing supervision counter n register 4
FFFF5068 _H	TSCCMP4	Comparison value of timing supervision counter n register 4
FFFF506C _H	TSCRLD4	Reload value of timing supervision counter n register 4
FFFF5074 _H	TSCCNT5	Count value of timing supervision counter n register 5
FFFF5078 _H	TSCCMP5	Comparison value of timing supervision counter n register 5
FFFF507C _H	TSCRLD5	Reload value of timing supervision counter n register 5

Section 10 Safety Guardian (SGA)

This section gives an overview of the SGA.

10.1 SGA Features

Number of instances This product has a single SGA.

Table 10-1 Instances of SGA

SGA	
Instances	1
Names	SGA (common area), SGAM, SGAC

Meaning of m in names Throughout this section, the SGAM and SGAC are collectively referred to by attaching the index "m" (m = M and C). The individual values (M and C) identify the respective areas. That is,

- SGAmESET indicates both SGAMESET and SGACESET.

Meaning of xx in signal names Throughout this section, the index "xx" (xx = 0 to 47) attached to the common part of the signal name collectively indicates SGATERRIN0 to SGATERRIN47. The individual values (0 to 47) identify the respective signals.

Register addresses All SGA register addresses are given as address offsets from the individual base addresses <SGA_base>, <SGAM_base>, or <SGAC_base>. The addresses of each area are listed in the following table.

Table 10-2 SGA Register Base Addresses

SGA Register	Address Label	Address
SGAM	<SGAM_base>	FF83 C000 _H
SGAC	<SGAC_base>	FF83 D000 _H
SGA	<SGA_base>	FF83 E000 _H

Clock supply All SGA provide one clock input.

Table 10-3 SGA Clock Supply

SGA Area	SGA Clock	Connected to
SGA, SGAM, SGAC	PCLK	Clock controller

Interrupts The SGA can generate the following interrupt requests.

Table 10-4 SGA Interrupt Requests

SGA Signal	Function	Connected to
SGATI	SGA interrupt	Interrupt controller INTISG

I/O signals The error input signals of the SGA are listed in the following table.

Table 10-5 SGA Error Input Signals (1/2)

SGA Signal	Function	Connected to
SGATERRIN0	CLMA0 error input	OSC_ERR
SGATERRIN1	CLMA1 error input	PLL_ERR
SGATERRIN2	CLMA2 error input	ROSC_ERR
SGATERRIN3	WDTA error input	WDTA_ERR
SGATERRIN4	LVI reset input	LVI_RES
SGATERRIN5	Compare unit error input	CMP_ERR
SGATERRIN6	Flash memory ECC error detection	FLASH_ED
SGATERRIN7	Flash memory ECC error detection (and correction)	FLASH_EC
SGATERRIN8	RAM ECC error detection	IRAM_ED
SGATERRIN9	RAM ECC error detection (and correction)	IRAM_EC
SGATERRIN10	Flash cache RAM ECC error detection	FCACHE_RAM_ED2
SGATERRIN11	Flash cache RAM ECC error detection	FCACHE_RAM_ED1
SGATERRIN12	Flash cache TAG ECC error detection	FCACHE_TAG_ED2
SGATERRIN13	Flash cache TAG ECC error detection	FCACHE_TAG_ED1
SGATERRIN14	CAN ECC error detection	CAN_ED
SGATERRIN 15 to SGATERRIN 17	Reserved	Reserved
SGATERRIN18	Unintentional enabling of self-diagnostic BIST	ET_BIST_ENABLE* ¹
SGATERRIN19	Unintentional enabling of self-diagnostic BIST	ET_BIST_ENABLE* ¹
SGATERRIN 20 to SGATERRIN 31	Reserved	Reserved
SGATERRIN32	Unintentional activation of code flash programming mode	FRB_PRG_ENABLE
SGATERRIN33	Unintentional prohibition of CLMA0	CLM0_DISABLE
SGATERRIN34	Unintentional prohibition of CLMA1	CLM1_DISABLE
SGATERRIN35	Unintentional prohibition of CLMA2	CLM2_DISABLE
SGATERRIN36	Unintentional enabling of self-diagnostic BIST	ET_BIST_ENABLE* ¹

Table 10-5 SGA Error Input Signals (2/2)

SGA Signal	Function	Connected to
SGATERRIN37	Reserved	Reserved
SGATERRIN38	Unintentional enabling of production test mode	TEST_ENABLE
SGATERRIN39	CPU mode error: This error is generated on detection of an unintentional change to the CPU operating mode.	CPU_MODE_ERR
SGATERRIN40	SGA compare error, internal loop back of the SGA error output. Inconsistency of the redundant SGA is indicated by this error.	SG_CMP_ERR
SGATERRIN41	Unintentional masking of an error signal: Since the BIST block toggles error signals, error generation during BIST execution is masked in accord with this signal. This signal also indicates whether or not error generation is masked beyond BIST execution.	SG_HW_BIST_ERR_EN
SGATERRIN 42 to SGATERRIN 47	Reserved	Reserved
SGATERRSWS	This signal indicates the state of writing to SGAmESET.	SGA internal connection
SGATERRLB	Loop-back signal from the signal on the ERROROUT pin (i.e. this signal indicates the level on the ERROROUT pin).	ERROROUT pin

Note 1. The signals to indicate unintentional enabling of errors in self-diagnostic BIST are connected in common to the SGA error input (SGAERRIN18, 19, 36).

I/O signals The I/O signals of the SGA are listed in the following table.

Table 10-6 SGA Input Signals

SGA Signal	Function	Connected to
SGATERROUTZ	SGA error output used for signaling of errors to an external watchdog.	ERROROUT pin
SGARES	SGA internal reset request can force an internal reset of the device.	Reset controller
SGATRERRO	SGA error output for Hi-Z control of TAPA. In case of an error, signaled by SGATERROUTZ, a Hi-Z state can automatically be enabled for the motor control timer outputs.	PIC
SGATTIN	SGA timer input. The dynamic behavior of the SGATERROUTZ can be configured by this timer input.	TAUB0 ch15 OSTM1

10.2 SGA Functional Overview

The safety guardian (SGA) collects all the internal error signals coming from the different error sources and monitoring circuits. These errors are for instance generated by the clock monitor, ECC circuit, compare unit, and other monitoring units.

Features summary

The SGA has the following features.

- Error collection, status indication, and individual treatment
 - Error generation via SGATERROUTZ
 - Interrupt generation via SGATI
 - Internal reset generation via $\overline{\text{SGARES}}$

The SGA is implemented redundant. Some of the redundant registers are accessed simultaneously by one write operation and some registers have to be accessed individually. This allows an individual functional test by software of the two safety guardian instances.

- SGA (safety guardian) register area represents the common register area where the redundant registers are accessed simultaneously by one write operation.
- SGAM (safety guardian master) register area represents a register area where the SGA master registers are accessed individually.
- SGAC (safety guardian checker) register area represents a register area where the SGA checker registers are accessed individually.

The following block diagram shows the mapping of the SGA register areas.

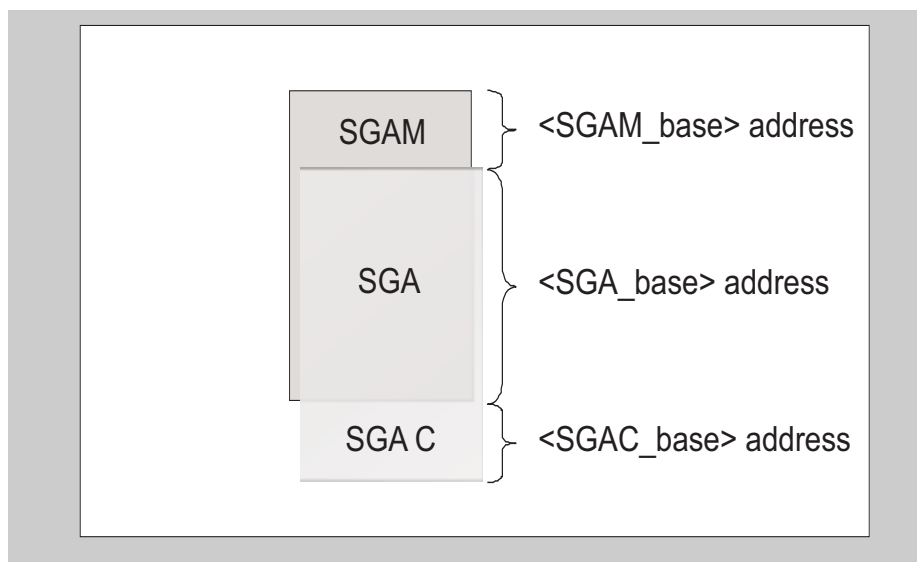

Figure 10-1 Register Areas of the Redundant SGA

The following block diagram shows the main components of the SGA.

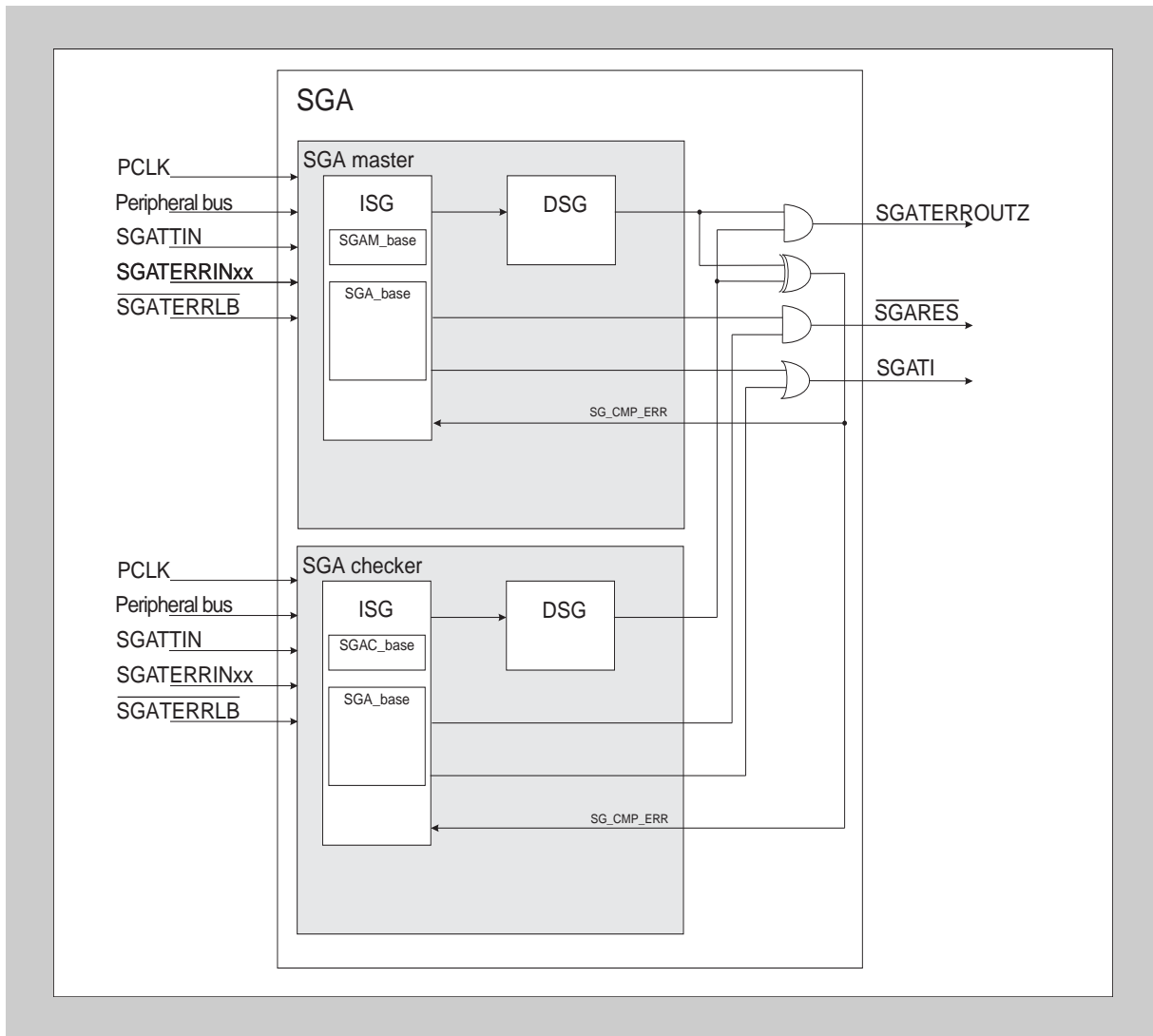

Figure 10-2 Block Diagram of the Redundant SGA

The SGA is divided into the indirect safety guardian (ISG) and direct safety guardian (DSG).

- ISG is used for static configuration of the error sources.
- DSG consists of combinatorial logic only. Therefore, it is robust against clock faults and able to indicate an error towards SGATERROUTZ even in case of clock faults.

The SGA has the following external connections.

- Inputs
 - Error inputs SGATERRINxx from all internal error sources and monitoring units. The SGA master and SGA checker have identical error input signals.
 - The SGATTIN timer input connection is for generating dynamic error operation.
 - Error loop-back $\overline{\text{SGATERRLB}}$ is used to read back the error output level from the ERROROUT pin of the device.
- Outputs
 - Interrupt output SGATI
 - Internal reset output $\overline{\text{SGARES}}$
 - Error output SGATERROUTZ

10.3 Functional Description

10.3.1 SGA Operating States

The SGA operation can be sub-divided into four main phases.

- Reset: Hardware initialization of the device.
- Start-up test: Execution/Evaluation of self-diagnostic BIST and software self-test
- Application: Configuration of SGA and execution of user application
- Error: Error handling according to SGA configuration

The following block diagram shows an example of the different phases of operation.

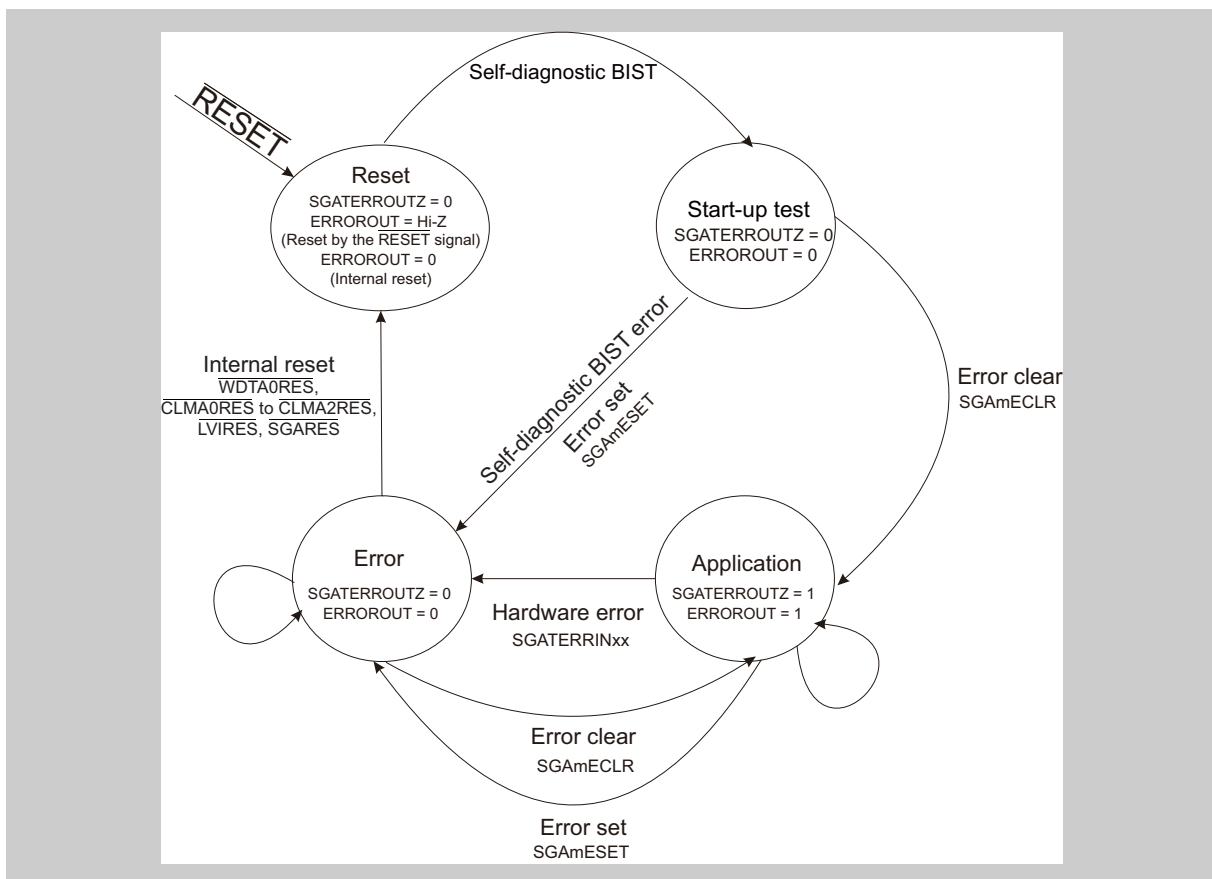

Figure 10-3 SGA Error States and Phases

10.3.2 SGA Configuration Overview

The SGA supports the following functions.

- Error set/clear register
 - The error set/clear register is used to enter or release the active or inactive error state. Where active (error set) means that the error output SGATERROUTZ is low independent from the error inputs SGATERRINxx. Inactive (error clear) means that the error output SGATERROUTZ is high (or toggled by timer input) until an error is indicated by SGATERRINxx.
- Error source status registers
 - Represent the status of the individual error source input SGATERRINxx.
- Error source status clear registers
 - Are used to clear the individual error status.
- Error mask registers
 - Each individual error input SGATERRINxx can be masked towards the error output SGATERROUZ.
- Internal reset configuration registers
 - Each individual error input SGATERRINxx can be configured to generate an internal reset or not.
- Interrupt configuration register
 - Interrupt generation by SGATI can be configured for some error inputs SGATERRIN41 to SGATERRIN32.
- Pseudo error registers
 - This function allows functional tests of the error path by pseudo error injection.
- Error pulse configuration register
 - The SGATERROUTZ error-output signal can be configured for dynamic or non-dynamic operation. In dynamic mode, the error-output signal operates in accord with the level on SGATTIN.

The register and signal dependency is shown below.

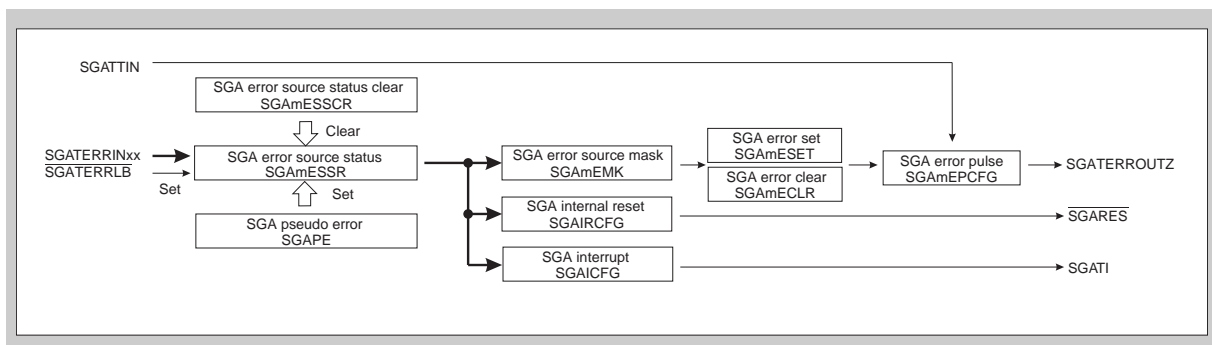

Figure 10-4 SGA Register and Signal Dependency

10.3.3 Operations for Error Output

The error output SGATERROUZ is connected to the ERROROUT pin.

The error output can be configured for two different modes of operation, non-dynamic or dynamic.

Table 10-7 Operating Modes for Error Output

Error Status SGAmESSTR y.SGAmSSE0 19-000/ SGAmSSE13 1-100 (y = 0, 1)	Operating Mode SGASL0 Bit	Error Output Operating Mode	Error Output Level	Error Status
0	0	Non-dynamic	High	No error
	1	Dynamic	Toggles (according to SGATTIN timer configuration)	No error
1	0	Non-dynamic	Low	Error
	1	Dynamic	Low	Error

Caution The following programming procedure should be considered.

(1) Dynamic Mode Enable

- 1) Set the SGAEMK0 and SGAEMK1 registers.
- 2) Initialize the related timer (connected to SGATTIN).
- 3) Drive the error output to high level by setting the SGAmECLR.SGAmECT bit to 1. Refer to the note in Section 10.4.2 (2), SGAmECLR - SGAm Error Clear Trigger Register.
- 4) Set the SGAEPCFG.SGASL0 bit to 1 for dynamic mode.
- 5) Start the timer.

Note Set the timer cycle according to the characteristics of the external device to be connected.

(2) Dynamic Mode Disable

- 1) Set the SGAEMK0 and SGAEMK1 registers.
- 2) Drive the error output to low level by setting the SGAmESET.SGAmEST bit to 1. Refer to the note in Section 10.4.2 (1), SGAmESET SGAm Error Set Trigger Register.
- 3) Stop the timer.
- 4) Set the SGAEPCFG.SGASL0 bit to 0 for non-dynamic mode.

10.3.4 Loop-Back Function

The SGA supports a loop-back function which is used to check the error path from the SGA to the ERROROUT pin. The SGATERRLB is connected to the ERROROUT pin and the level of the output is reflected to the SGAmSSE131 bit, shown in Table 10-14, SGAmESSTR1 Register Contents.

If a loop-back test is to be run, do so while all error flags that are not masked by settings in SGAEMK0/1 are clear.

(1) Example of a Loop-Back Test after Reset

- 1) After any reset, the error output has a "low level".
- 2) Read the SGAMESSTR1.SGAMSSE131 and SGACESSTR1.SGACSSE131 bits and check for "0".
- 3) Clear all internal error sources by the SGAESSTC0 and SGAESSTC1 registers.
- 4) Mask SG_CMP_ERR by setting the SGAEMK1.SGAEMK108 bit.
- 5) Set error output to "high level" by the SGAMECLR and SGACECLR registers.
- 6) Read the SGAMESSTR1.SGAMSSE131 and SGACESSTR1.SGACSSE131 bits and check for "1".
- 7) Set error output to "low level" by the SGAMESET register.
- 8) Read the SGAMESSTR1.SGAMSSE131 and SGACESSTR1.SGACSSE131 bits and check for "0".
- 9) Clear the error by the SGAESSTC1.SGACLSSE130 bit.
- 10) Set error output to "high level" by the SGAMECLR register.
- 11) Read the SGAMESSTR1.SGAMSSE131 and SGACESSTR1.SGACSSE131 bits and check for "1".
- 12) Set error output to "low level" by the SGACESET register.
- 13) Read the SGAMESSTR1.SGAMSSE131 and SGACESSTR1.SGACSSE131 bits and check for "0".
- 14) Set error output to "low level" by the SGAMESET and SGACESET registers.
- 15) Clear the error by the SGAESSTC1.SGACLSSE108 and SGAESSTC1.SGACLSSE130 bits.
- 16) Unmask SG_CMP_ERR by clearing the SGAEMK1.SGAEMK108 bit.

Refer to the note in Section 10.4.2 (1), SGAmESET SGAm Error Set Trigger Register.

10.3.5 Pseudo Error Generation

The SGA supports a pseudo error injection function to “emulate” an error for test or debug purposes. The operation of the SGA during injection of pseudo errors is identical to the occurrence of real errors. This means that all configurations for error masks, interrupt, or internal reset apply in the same way.

The pseudo error generation can be used:

- for debug purposes to generate errors and check for instance the operation of the software for
 - SGA interrupts (SGATI)
 - Internal reset ($\overline{\text{SGARES}}$)
 - error output (SGATERROUTZ)
- for test purposes after reset to perform a functional test of the error source status registers SGAMESSTR0 and SGAMESSTR1. This test can be combined with the loop-back function.

A pseudo-error can be generated by setting the error source bit (SGAPE100 to SGAPE108 or SGAPE000 to SGAPE019) for the given source in the SGAPE0 or SGAPE1 register to 1.

10.3.6 Error Status

The error status is indicated by the SGA_mESSTR0 and SGA_mESSTR1 registers. The error status is only cleared after external reset by $\overline{\text{RESET}}$. In case of an internal reset, the status is kept and the error source can be evaluated afterwards by reading the SGA_mESSTR0 and SGA_mESSTR1 registers. Additionally, these registers are excluded from the self-diagnostic BIST in order to not destroy their content.

10.3.7 Writing to Protected Registers

Write protected registers are protected from inadvertent write access due to erroneous program execution, etc. An overview of the related registers is shown in Table 10-10, Overview of SGA Registers.

(1) Protection Unlock Sequence

Write access to a write protected register is only possible within a special protection unlock sequence.

1. Write the fixed value 0000 00A5_H to the protection command registers SGAPCMD1 and SGAmPCMD0.
2. Write the desired value to the protected registers of SGA and SGAm.
3. Write the bit-wise inversion of desired value to the protected registers of SGA and SGAm.
4. Write the desired value to the protected registers of SGA and SGAm.
5. Check successful write of the desired value to the protected register by checking that SGAPS.SGAPRERR = 0.

In case of any access to another register between step 1 to step 4 of the above sequence, the protection mechanism behaves as follows.

- If the second register belongs to the SGA, the write to the protected register fails (indicated by SGAPS.SGAPRERR = 1). The entire sequence has to be restarted at step 1.
- If the second register does not belong to the SGA, the protection unlock sequence is not disrupted and the write to the first register can be completed successfully.

Note For sequences of SGAPCMD1 and SGAmPCMD0 registers, the status of the protection unlock sequence is commonly indicated by the SGAPS.SGAPRERR flag. Therefore, it is recommended not to intermix protection unlock sequences of SGAPCMD1 and SGAmPCMD0.

In case the protection unlock sequence is interrupted, the protection mechanism behaves as follows.

- Interrupts during protection unlock sequence
If an interrupt is acknowledged within the above protection unlock sequence and the interrupt service routine does not access any register of the SGA, the protection unlock sequence is not disrupted and the write to the protected register can be successfully completed after returning from the interrupt service routine.

Caution All protected registers as well as the SGA protection command registers SGAPCMD1 and SGAmPCMD0 must be accessed in 32-bit units.

10.4 Registers

This section contains a description of all registers of the SGA.

10.4.1 Overview of SGA Registers

The SGA is controlled and operated by the following registers.

Table 10-8 Overview of SGA Master Registers

Register Name	Symbol	Write Protected by Special Sequence	Address
SGA master error set trigger register	SGAMESET	Enabled	<SGAM_base>
SGA master error clear trigger register	SGAMECLR	Enabled	<SGAM_base> + 4 _H
SGA master error source status register 0	SGAMESSTR0	Disabled	<SGAM_base> + 8 _H
SGA master error source status register 1	SGAMESSTR1	Disabled	<SGAM_base> + C _H
SGA master protection command register	SGAMPCMD0	Not applicable	<SGAM_base> + 10 _H

Table 10-9 Overview of SGA Checker Registers

Register Name	Symbol	Write Protected by Special Sequence	Address
SGA checker error set trigger register	SGACESET	Enabled	<SGAC_base>
SGA checker error clear trigger register	SGACECLR	Enabled	<SGAC_base> + 4 _H
SGA checker error source status register 0	SGACESSTR0	Disabled	<SGAC_base> + 8 _H
SGA checker error source status register 1	SGACESSTR1	Disabled	<SGAC_base> + C _H
SGA checker protection command register	SGACPCMD0	Not applicable	<SGAC_base> + 10 _H

Table 10-10 Overview of SGA Registers

Register Name	Symbol	Write Protected by Special Sequence	Address
SGA error pulse configuration register	SGAEP_CFG	Enabled	<SGA_base>
SGA interrupt configuration register	SGAICFG1	Enabled	<SGA_base> + 4 _H
SGA internal reset configuration register 0	SGAIRCFG0	Enabled	<SGA_base> + 8 _H
SGA internal reset configuration register 1	SGAIRCFG1	Enabled	<SGA_base> + C _H
SGA SGATERROUTZ mask register 0	SGAEMK0	Enabled	<SGA_base> + 10 _H
SGA SGATERROUTZ mask register 1	SGAEMK1	Enabled	<SGA_base> + 14 _H
SGA error source status clear register 0	SGAESSTC0	Enabled	<SGA_base> + 18 _H
SGA error source status clear register 1	SGAESSTC1	Enabled	<SGA_base> + 1C _H
SGA protection command register	SGAPCMD1	Not applicable	<SGA_base> + 20 _H
SGA protection status register	SGAPS	Not applicable	<SGA_base> + 24 _H
SGA pseudo error trigger register 0	SGAPE0	Enabled	<SGA_base> + 28 _H
SGA pseudo error trigger register 1	SGAPE1	Enabled	<SGA_base> + 2C _H
SGA error pulse output control register	SGAEPCTL	Not applicable	FF83 F020 _H

10.4.2 SGA Registers Details

(1) SGAmESET SGAm Error Set Trigger Register

This register is used to set error output signals to the low (active) level.

The given error output is immediately set to the active level after a value is written to this register. This response is not maskable.

Access This register can be written in 32-bit units. Writing to this register is protected by a sequence of instructions.

Address <SGAm_base>

Initial value 0000 0000_H

This register is initialized by a reset from any source.

31	30	29	28	27	26	25	24	23	22	21	20	19	18	17	16
0	0	0	0	0	0	0	0	0	0	0	0	0	0	0	0
W	W	W	W	W	W	W	W	W	W	W	W	W	W	W	W
15	14	13	12	11	10	9	8	7	6	5	4	3	2	1	0
0	0	0	0	0	0	0	0	0	0	0	0	0	0	0	SGAm EST
W	W	W	W	W	W	W	W	W	W	W	W	W	W	W	W

Table 10-11 SGAmEST Register Contents

Bit position	Bit Name	Function
0	SGAmEST	SGA error set trigger bit 0: Writing 0 to this bit is ignored. 1: Initiate an active state of the SGATERROUTZ (low level).

Caution Setting the error output via the SGAmESET register will generate the error (in the SGAmESSTR1.SGAmSSE108 and SGAmESSTR1.SGAmSSE130 bits).

Therefore, the following has to be set in advance.

- 1) Set the SGAEMK1.SGAEMK108 bit to "masked".
- 2) Prevent the generation of SGATI interrupts by setting the SGAICFG1.SGAIE108 bit to "prohibited".
- 3) Prevent generation of the SGARES reset by setting the SGAIRCFG1.SGAIRE108 bit to "prohibited".
- 4) Set the error output bit in the SGAmESET register.
- 5) Clear error flags by setting the SGAESSTC1.SGACLSSE108 and SGAESSTC1.SGACLSSE130 bits.
- 6) Make the following settings in accord with the condition of usage for the SGATERRIN40 error.
 - If an SGATERROUTZ error is being output, set the SGAEMK1.SGAEMK108 bit to "not masked".
 - If an SGATI interrupt is being generated, set the SGAICFG1.SGAIE108 bit to "enabled".
 - If a SGARES reset is being generated, set the SGAIRCFG1.SGAIRE108 bit to "enabled".

(2) SGAmECLR - SGAm Error Clear Trigger Register

This register is used to deactivate error output (by placing the signal at the high level). If no further errors are pending, the setting is immediately effective for the signal on the error pin.

Access This register can be written in 32-bit units. Writing to this register is protected by a sequence of instructions.

Address <SGAm_base> + 4_H

Initial value 0000 0000_H

This register is initialized by a reset from any source.

31	30	29	28	27	26	25	24	23	22	21	20	19	18	17	16
0	0	0	0	0	0	0	0	0	0	0	0	0	0	0	0
W	W	W	W	W	W	W	W	W	W	W	W	W	W	W	W
15	14	13	12	11	10	9	8	7	6	5	4	3	2	1	0
0	0	0	0	0	0	0	0	0	0	0	0	0	0	0	SGAmECT
W	W	W	W	W	W	W	W	W	W	W	W	W	W	W	W

Table 10-12 SGAmECLR Register Contents

Bit position	Bit Name	Function
0	SGAmECT	SGA error clear trigger bit 0: Writing 0 to this bit is ignored. 1: Initiate an inactive state of the SGATERROUTZ (high level).

- Caution 1. Clearing of SGATERROUTZ is only possible if all errors, not masked by SGAEMK0/1, are cleared beforehand.
- Caution 2. Clearing the error output via the SGAmECLR register will generate the error (in the SGAmESSTR1.SGAmSSE108 bit).
- Therefore, the following has to be set in advance.
- 1) Set the SGAEMK1.SGAEMK108 bit to "masked".
 - 2) Prevent the generation of SGATI interrupts by setting the SGAICFG1.SGAIE108 bit to "prohibited".
 - 3) Prevent generation of the $\overline{\text{SGARES}}$ reset by setting the SGAIRCFG1.SGAIRE108 bit to "prohibited".
 - 4) Clear the error output bit in the SGAmECLR register.
 - 5) Clear error flags by setting the SGAESSTC1.SGACLSSE108 bit.
 - 6) Make the following settings in accord with the condition of usage for the SGATERRIN40 error.
 - If an SGATERROUTZ error is being output, set the SGAEMK1.SGAEMK108 bit to "not masked".
 - If an SGATI interrupt is being generated, set the SGAICFG1.SGAIE108 bit to "enabled".
 - If a $\overline{\text{SGARES}}$ reset is being generated, set the SGAIRCFG1.SGAIRE108 bit to "enabled".
- Caution 3. Once the setting for dynamic mode has been made, we recommend not switching back to non-dynamic mode. This is because doing so raises the possibility of glitches at times of error output. For details, see Section 10.3.3, Operations for Error Output.

(3) SGAmESSTR0 - SGAm Error Source Status Register 0

This register shows the status of each error source. The status is indicated regardless of mask settings.

Access This register can be read in 32-bit units.

Address <SGAm_base> + 8_H

Initial value 0000 0000_H

This register is initialized by $\overline{\text{RESET}}$ only.

Note This register is not tested by the self-diagnostic BIST.

31	30	29	28	27	26	25	24	23	22	21	20	19	18	17	16
0	0	0	0	0	0	0	0	0	0	0	0	SGAm SSE 019	SGAm SSE 018	0	SGAm SSE 016*
R	R	R	R	R	R	R	R	R	R	R	R	R	R	R	R
15	14	13	12	11	10	9	8	7	6	5	4	3	2	1	0
SGAm SSE 015	SGAm SSE 014	SGAm SSE 013	SGAm SSE 012	SGAm SSE 011	SGAm SSE 010	SGAm SSE 009	SGAm SSE 008	SGAm SSE 007	SGAm SSE 006	SGAm SSE 005	SGAm SSE 004	SGAm SSE 003	SGAm SSE 002	SGAm SSE 001	SGAm SSE 000
R	R	R	R	R	R	R	R	R	R	R	R	R	R	R	R

Table 10-13 SGAmESSTR0 Register Contents

Bit position	Bit Name	Function
19 to 18, 16 to 0	SGAmSSE019 to SGAmSSE018, SGAmSSE016 to SGAmSSE000	SGAmSSE019 to SGAmSSE000 correspond to SGATERRIN19 to SGATERRIN00. 0: SGATERRINxx error not occurred 1: SGATERRINxx error occurred

- Caution 1. The self-diagnostic BIST leads to setting (to 1) of the SGAmESSTR0.SGAmSSE018 and SGAmESSTR0.SGAmSSE019 bits. They should be cleared by software.
- Caution 2. The generation of an internal reset may lead to setting of the SGAmESSTR0.SGAmSSE006 bit (indicating detection of an ECC error in flash memory) and the SGAmESSTR0.SGAmSSE007 bit (indicating detection of an ECC error in flash memory, including when the error has been corrected). For reliable detection of ECC errors, set the SGAIRCFG0.SGAIRE006 and SGAIRCFG0.SGAIRE007 bits to suppress internal resetting by the SGA (i.e. setting the bits to 0) and test the error source flags in register CECCER.

(4) SGAmESSTR1 - SGAm Error Source Status Register 1

This register shows the status of each error source. The status is indicated regardless of mask settings.

Access This register can be read in 32-bit units.

Address <SGAm_base> + C_H

Initial value 0000 0000_H

This register is initialized by $\overline{\text{RESET}}$ only.

However, the SGAmSSE130 bit is initialized by a reset from any source.

Note This register is not tested by the self-diagnostic BIST.

31	30	29	28	27	26	25	24	23	22	21	20	19	18	17	16
SGAmSSE131	SGAmSSE130	0	0	0	0	0	0	0	0	0	0	0	0	0	0
R	R	R	R	R	R	R	R	R	R	R	R	R	R	R	R
15	14	13	12	11	10	9	8	7	6	5	4	3	2	1	0
0	0	0	0	0	0	SGAmSSE109	SGAmSSE108	SGAmSSE107	SGAmSSE106	SGAmSSE105	SGAmSSE104	SGAmSSE103	SGAmSSE102	SGAmSSE101	SGAmSSE100
R	R	R	R	R	R	R	R	R	R	R	R	R	R	R	R

Table 10-14 SGAmESSTR1 Register Contents

Bit position	Bit Name	Function
31	SGAmSSE131	Indicates the error output loop-back state (SGATERRLB). 0: Error output (the ERROROUT pin) is low level 1: Error output (the ERROROUT pin) is high level
30	SGAmSSE130	Indicates the SGAmESET write status (SGATERRSWS). 0: No error 1: Error is set by SGAmESET.SGAmEST
9 to 0	SGAmSSE109 to SGAmSSE100	SGAmSSE109 to SGAmSSE100 correspond to SGATERRIN41 to SGATERRIN32. 0: SGATERRINxx error not occurred 1: SGATERRINxx error occurred

Caution Since self-diagnostic BIST leads to setting of the SGAmESSTR1.SGATmSSE104 and SGAmESSTR1.SGATmSSE109 bits (to 1), software should clear these bits to 0.

(5) SGAmPCMD0 - SGAm (Master/Checker) Protection Command Register

This register is the protection command register for the SGAm (master/checker) register. For a list of protected registers, refer to Table 10-10, Overview of SGA Registers.

For details on the register write protection sequence, refer to Section 10.3.7, Writing to Protected Registers. The status of the protected write sequence is indicated in the description in (15) SGAPS - SGA Protection Status Register.

Access This register can be written in 32-bit units.

Address <SGAm_base> + 10_H

Initial value Undefined

31	30	29	28	27	26	25	24	23	22	21	20	19	18	17	16
0	0	0	0	0	0	0	0	0	0	0	0	0	0	0	0
W	W	W	W	W	W	W	W	W	W	W	W	W	W	W	W
15	14	13	12	11	10	9	8	7	6	5	4	3	2	1	0
0	0	0	0	0	0	0	0	SGAm0REG[7:0]							
W	W	W	W	W	W	W	W	W	W	W	W	W	W	W	W

Table 10-15 SGAPmCMD0 Register Contents

Bit position	Bit Name	Function
7 to 0	SGAm0REG[7:0]	Protection commands to enable writing to SGAm registers

(6) SGAEPCFG - SGA Error Pulse Configuration Register

This register is used to specify the operating mode for the error output signal.

Access This register can be read/written in 32-bit units. Writing to this register is protected by a sequence of instructions.

Address <SGA_base>

Initial value 0000 0000_H

This register is initialized by a reset from any source.

31	30	29	28	27	26	25	24	23	22	21	20	19	18	17	16
0	0	0	0	0	0	0	0	0	0	0	0	0	0	0	0
R	R	R	R	R	R	R	R	R	R	R	R	R	R	R	R
15	14	13	12	11	10	9	8	7	6	5	4	3	2	1	0
0	0	0	0	0	0	0	0	0	0	0	0	0	0	0	SGAS LO
R	R	R	R	R	R	R	R	R	R	R	R	R	R	R	R/W

Table 10-16 SGAEPCFG Register Contents

Bit position	Bit Name	Function
0	SGASLO	Error output operation setting for SGATERROUTZ 0: Non-dynamic mode 1: Dynamic mode. Dynamic error signals are generated from the timer input signal connected to SGATTIN.

Caution After setting the dynamic mode, it is recommended not to change to non-dynamic mode again, because there is a possibility of a glitch at the error output. For details, see Section 10.3.3, Operations for Error Output.

(7) SGAICFG1 - SGA Interrupt Configuration Register 1

This register is used to set generation of the SGATI interrupt. Specifically, the generation of interrupts in response to errors (SGATERRINxx) is selectable.

Access This register can be read/written in 32-bit units. Writing to this register is protected by a sequence of instructions.

Address <SGA_base> + 4_H

Initial value 0000 0000_H

This register is initialized by a reset from any source.

31	30	29	28	27	26	25	24	23	22	21	20	19	18	17	16
0	0	0	0	0	0	0	0	0	0	0	0	0	0	0	0
R	R	R	R	R	R	R	R	R	R	R	R	R	R	R	R
15	14	13	12	11	10	9	8	7	6	5	4	3	2	1	0
0	0	0	0	0	0	SGAI E109	SGA IE108	SGA IE107	SGA IE106	SGA IE105	SGA IE104	SGA IE103	SGA IE102	SGA IE101	SGA IE100
R	R	R	R	R	R	R/W	R/W	R/W	R/W	R/W	R/W	R/W	R/W	R/W	R/W

Table 10-17 SGAICFG1 Register Contents

Bit position	Bit Name	Function
9 to 0	SGAIE109 to SGAIE100	SGAIE109 to SGAIE100 correspond to the error input signals SGATERRIN41 to SGATERRIN32. SGATI interrupt disable/enable 0: Disabled. SGATI is not generated by the occurrence of SGATERRINxx. 1: Enabled. SGATI is generated by the occurrence of SGATERRINxx.

(8) SGAIRCFG0 - SGA Internal Reset Configuration Register 0

This register is used to set the generation of internal resets in response to internal errors.

Access This register can be read/written in 32-bit units. Writing to this register is protected by a sequence of instructions.

Address <SGA_base> + 8_H

Initial value 0000 0000_H

This register is initialized by a reset from any source.

31	30	29	28	27	26	25	24	23	22	21	20	19	18	17	16
0	0	0	0	0	0	0	0	0	0	0	0	SGA IRE 019	SGA IRE 018	0	SGA IRE 016*
R	R	R	R	R	R	R	R	R	R	R	R	R/W	R/W	R	R/W
15	14	13	12	11	10	9	8	7	6	5	4	3	2	1	0
SGA IRE 015	SGA IRE 014	SGA IRE 013	SGA IRE 012	SGA IRE 011	SGA IRE 010	SGA IRE 009	SGA IRE 008	SGA IRE 007	SGA IRE 006	SGA IRE 005	SGA IRE 004	SGA IRE 003	SGA IRE 002	SGA IRE 001	SGA IRE 000
R/W	R/W	R/W	R/W	R/W	R/W	R/W	R/W	R/W	R/W	R/W	R/W	R/W	R/W	R/W	R/W

Table 10-18 SGAIRCFG0 Register Contents

Bit position	Bit Name	Function
19, 18, and 16 to 0	SGAIRE019, SGAIRE018, and SGAIRE016 to SGAIRE000	SGAIRE019 to SGAIRE000 correspond to the error input signals SGATERRIN19 to SGATERRIN00. SGARES internal reset disable/enable 0: Disabled. $\overline{\text{SGARES}}$ is not generated by the occurrence of SGATERRINxx. 1: Enabled. $\overline{\text{SGARES}}$ is generated by the occurrence of SGATERRINxx.

Caution The generation of an internal reset may lead to the SGAmESSTR0.SGAmSSE006 bit (flash memory ECC error detection) and the SGAmESSTR0.SGAmSSE007 bit (flash memory ECC error detection, including when the error has been corrected) being set to 1. Accordingly, for the reliable detection of ECC errors, set the SGAIRCFG0.SGAIRE006 and SGAIRCFG0.SGAIRE007 bits to suppress internal resetting by the SGA (i.e. setting the bits to 0) and test the error source flags in register CECCER.

(9) SGAIRCFG1 - SGA Internal Reset Configuration Register 1

This register is used to set the generation of internal resets in response to internal errors.

Access This register can be read/written in 32-bit units. Writing to this register is protected by a sequence of instructions.

Address <SGA_base> + C_H

Initial value 0000 0000_H

This register is initialized by a reset from any source.

31	30	29	28	27	26	25	24	23	22	21	20	19	18	17	16
0	0	0	0	0	0	0	0	0	0	0	0	0	0	0	0
R	R	R	R	R	R	R	R	R	R	R	R	R	R	R	R
15	14	13	12	11	10	9	8	7	6	5	4	3	2	1	0
0	0	0	0	0	0	SGA IRE 109	SGA IRE 108	SGA IRE 107	SGA IRE 106	SGA IRE 105	SGA IRE 104	SGA IRE 103	SGA IRE 102	SGA IRE 101	SGA IRE 100
R	R	R	R	R	R	R/W	R/W	R/W	R/W	R/W	R/W	R/W	R/W	R/W	R/W

Table 10-19 SGAIRCFG1 Register Contents

Bit position	Bit Name	Function
9 to 0	SGAIRE109 to SGAIRE100	SGAIRE109 to SGAIRE100 correspond to the error input signals SGATERRIN41 to SGATERRIN32. SGARES internal reset disable/enable 0: Disabled. SGARES is not generated by the occurrence of SGATERRINxx. 1: Enabled. SGARES is generated by the occurrence of SGATERRINxx.

(10) SGAEMK0 - SGA Error Mask Register 0

This register is used to mask individual error sources (SGATERRINxx) for the error output signal SGATERROUTZ.

Access This register can be read/written in 32-bit units. Writing to this register is protected by a sequence of instructions.

Address <SGA_base> + 10_H

Initial value 0000 0000_H

This register is initialized by a reset from any source.

31	30	29	28	27	26	25	24	23	22	21	20	19	18	17	16
0	0	0	0	0	0	0	0	0	0	0	0	SGA EMK 019	SGA EMK 018	0	SGA EMK 016*
R	R	R	R	R	R	R	R	R	R	R	R	R/W	R/W	R	R/W
15	14	13	12	11	10	9	8	7	6	5	4	3	2	1	0
SGA EMK 015	SGA EMK 014	SGA EMK 013	SGA EMK 012	SGA EMK 011	SGA EMK 010	SGA EMK 009	SGA EMK 008	SGA EMK 007	SGA EMK 006	SGA EMK 005	SGA EMK 004	SGA EMK 003	SGA EMK 002	SGA EMK 001	SGA EMK 000
R/W	R/W	R/W	R/W	R/W	R/W	R/W	R/W	R/W	R/W	R/W	R/W	R/W	R/W	R/W	R/W

Table 10-20 SGAEMK0 Register Contents

Bit position	Bit Name	Function
19, 18, and 16 to 0	SGAEMK019, SGAEMK018, and SGAEMK016 to SGAEMK000	SGAEMK019 to SGAEMK000 correspond to the error input signals SGATERRIN19 to SGATERRIN00. SGATERROUTZ error output signal mask setting 0: Not masked. SGATERROUTZ enters the active or error state by occurrence of SGATERRINxx. 1: Masked. SGATERROUTZ does not enter the active or error state by occurrence of SGATERRINxx.

(11) SGAEMK1 - SGA Error Mask Register 1

This register is used to mask individual error sources (SGATERRINxx) for the error output signal SGATERROUTZ.

Access This register can be read/written in 32-bit units. Writing to this register is protected by a sequence of instructions.

Address <SGA_base> + 14_H

Initial value 0000 0000_H

This register is initialized by a reset from any source.

31	30	29	28	27	26	25	24	23	22	21	20	19	18	17	16
0	0	0	0	0	0	0	0	0	0	0	0	0	0	0	0
R	R	R	R	R	R	R	R	R	R	R	R	R	R	R	R
15	14	13	12	11	10	9	8	7	6	5	4	3	2	1	0
0	0	0	0	0	0	SGA EMK 109	SGA EMK 108	SGA EMK 107	SGA EMK 106	SGA EMK 105	SGA EMK 104	SGA EMK 103	SGA EMK 102	SGA EMK 101	SGA EMK 100
R	R	R	R	R	R	R/W	R/W	R/W	R/W	R/W	R/W	R/W	R/W	R/W	R/W

Table 10-21 SGAEMK1 Register Contents

Bit position	Bit Name	Function
9 to 0	SGAEMK109 to SGAEMK100	SGAEMK109 to SGAEMK100 correspond to the error input signals SGATERRIN41 to SGATERRIN32. SGATERROUTZ error output signal mask setting 0: Not masked. SGATERROUTZ is generated by the occurrence of SGATERRINxx. 1: Masked. SGATERROUTZ is not generated by the occurrence of SGATERRINxx.

(12) SGAESSTC0 - SGA Error Source Status Clear Register 0

This register is used to clear the individual error source status of the SGAESSTR0 register. The error status of both SGAM and SGAC is cleared simultaneously.

Access This register can be written in 32-bit units. Writing to this register is protected by a sequence of instructions.

Address <SGA_base> + 18_H

Initial value 0000 0000_H

This register is initialized by a reset from any source.

31	30	29	28	27	26	25	24	23	22	21	20	19	18	17	16
0	0	0	0	0	0	0	0	0	0	0	0	SGA CLSSE 019	SGA CLSSE 018	0	SGA CLSSE 016*
W	W	W	W	W	W	W	W	W	W	W	W	W	W	W	W
15	14	13	12	11	10	9	8	7	6	5	4	3	2	1	0
SGA CLSSE 015	SGA CLSSE 014	SGA CLSSE 013	SGA CLSSE 012	SGA CLSSE 011	SGA CLSSE 010	SGA CLSSE 009	SGA CLSSE 008	SGA CLSSE 007	SGA CLSSE 006	SGA CLSSE 005	SGA CLSSE 004	SGA CLSSE 003	SGA CLSSE 002	SGA CLSSE 001	SGA CLSSE 000
W	W	W	W	W	W	W	W	W	W	W	W	W	W	W	W

Table 10-22 SGAmESSTC0 Register Contents

Bit position	Bit Name	Function
19,18, and 16 to 0	SGACLSSE019, SGACLSSE018, and SGACLSSE016 to SGACLSSE000	Controls the status clearing of the SGAmESSTR0.SGASSE019 to SGASSE000 bits. 0: No action. Writing to this bit is ignored. 1: The related error status SGASSE0xx is cleared.

(13) SGAESSTC1 - SGA Error Source Status Clear Register 1

This register is used to clear the individual error source status of the SGAESSTR1 register. The error status of both SGAM and SGAC is cleared simultaneously.

Access This register can be written in 32-bit units. Writing to this register is protected by a sequence of instructions.

Address <SGA_base> + 1C_H

Initial value 0000 0000_H

This register is initialized by a reset from any source.

31	30	29	28	27	26	25	24	23	22	21	20	19	18	17	16
0	SGA CLSSE 130	0	0	0	0	0	0	0	0	0	0	0	0	0	0
W	W	W	W	W	W	W	W	W	W	W	W	W	W	W	W
15	14	13	12	11	10	9	8	7	6	5	4	3	2	1	0
0	0	0	0	0	0	SGA CLSSE 109	SGA CLSSE 108	SGA CLSSE 107	SGA CLSSE 106	SGA CLSSE 105	SGA CLSSE 104	SGA CLSSE 103	SGA CLSSE 102	SGA CLSSE 101	SGA CLSSE 100
W	W	W	W	W	W	W	W	W	W	W	W	W	W	W	W

Table 10-23 SGAESSTC1 Register Contents

Bit position	Bit Name	Function
30	SGACLSSE130	Controls the status clearing of the SGAESSTR1.SGASSE130 bit. 0: No action. Writing to this bit is ignored. 1: The related error status SGASSE130 is cleared.
9 to 0	SGACLSSE109 to SGACLSSE100	Controls the status clearing of the SGAESSTR1.SGASSE109 to SGASSE100 bits 0: No action. Writing to this bit is ignored. 1: The related error status SGASSE1 is cleared.

(14) SGAPCMD1 - SGA Protection Command Register

This register is the protection command register for the SGA register. For a list of protected registers, refer to Table 10-10, Overview of SGA Registers.

For details about the register write protection sequence, refer to Section 10.3.7, Writing to Protected Registers.

Access This register can be written in 32-bit units.

Address <SGA_base> + 20_H

Initial value Undefined

31	30	29	28	27	26	25	24	23	22	21	20	19	18	17	16
0	0	0	0	0	0	0	0	0	0	0	0	0	0	0	0
W	W	W	W	W	W	W	W	W	W	W	W	W	W	W	W
15	14	13	12	11	10	9	8	7	6	5	4	3	2	1	0
0	0	0	0	0	0	0	0	SGA1REG[7:0]							
W	W	W	W	W	W	W	W	W	W	W	W	W	W	W	W

Table 10-24 SGAPCMD1 Register Contents

Bit position	Bit Name	Function
7 to 0	SGA1REG [7:0]	Protection commands to enable writing to SGA registers

(15) SGAPS - SGA Protection Status Register

This register is used to verify whether the write protected register has been written successfully or not.

For details, refer to Section 10.3.7, Writing to Protected Registers.

Access This register can be read in 32-bit units.

Address <SGA_base> + 24_H

Initial value 0000 0000_H

This register is initialized by a reset from any source.

31	30	29	28	27	26	25	24	23	22	21	20	19	18	17	16
0	0	0	0	0	0	0	0	0	0	0	0	0	0	0	0
R	R	R	R	R	R	R	R	R	R	R	R	R	R	R	R
15	14	13	12	11	10	9	8	7	6	5	4	3	2	1	0
0	0	0	0	0	0	0	0	0	0	0	0	0	0	0	SGA PRE RR
R	R	R	R	R	R	R	R	R	R	R	R	R	R	R	R

Table 10-25 SGAPS Register Contents

Bit position	Bit Name	Function
0	SGAPRERR	Indicates whether writing to a write protected register failed or was successful. 0: Writing was successfully completed. 1: Writing failed.

(16) SGAPE0 - SGA Pseudo Error Register 0

This register is used to generate a pseudo error for test purposes. The SGA operation in response to the generation of a pseudo error is identical to that in response to a real error signal on SGATERRINxx.

Access This register can be written in 32-bit units. Writing to this register is protected by a sequence of instructions.

Address <SGA_base> + 28_H

Initial value 0000 0000_H

This register is initialized by a reset from any source.

31	30	29	28	27	26	25	24	23	22	21	20	19	18	17	16
0	0	0	0	0	0	0	0	0	0	0	0	SGA PE 019	SGA PE 018	0	SGA PE 016*
W	W	W	W	W	W	W	W	W	W	W	W	W	W	W	W
15	14	13	12	11	10	9	8	7	6	5	4	3	2	1	0
SGA PE 015	SGA PE 014	SGA PE 013	SGA PE 012	SGA PE 011	SGA PE 010	SGA PE 009	SGA PE 008	SGA PE 007	SGA PE 006	SGA PE 005	SGA PE 004	SGA PE 003	SGA PE 002	SGA PE 001	SGA PE 000
W	W	W	W	W	W	W	W	W	W	W	W	W	W	W	W

Table 10-26 SGAPE0 Register Contents

Bit position	Bit Name	Function
19, 18, and 16 to 0	SGAPE019, SGAPE018, and SGAPE016 to SGAPE000	SGAPE019 to SGAPE000 correspond to SGATERRIN19 to SGATERRIN00. 0: No action. The SGATERRINxx error is not generated. 1: A pseudo error is generated in the same way as SGATERRINxx.

Caution SGATERRIN18, SGATERRIN19, and SGATERRIN36 cannot be generated simultaneously with other pseudo errors.

(17) SGAPE1 - SGA Pseudo Error Register 1

This register is used to generate a pseudo error for test purposes. The SGA operation in response to the generation of a pseudo error is identical to that in response to a real error signal on SGATERRINxx. This register is write-protected, so writing only proceeds when done in the specified sequence.

Access This register can be written in 32-bit units.

Address <SGA_base> + 2C_H

Initial value 0000 0000_H

This register is initialized by a reset from any source.

31	30	29	28	27	26	25	24	23	22	21	20	19	18	17	16
0	0	0	0	0	0	0	0	0	0	0	0	0	0	0	0
W	W	W	W	W	W	W	W	W	W	W	W	W	W	W	W
15	14	13	12	11	10	9	8	7	6	5	4	3	2	1	0
0	0	0	0	0	0	SGA PE 109	SGA PE 108	SGA PE 107	SGA PE 106	SGA PE 105	SGA PE 104	SGA PE 103	SGA PE 102	SGA PE 101	SGA PE 100
W	W	W	W	W	W	W	W	W	W	W	W	W	W	W	W

Table 10-27 SGAPE1 Register Contents

Bit position	Bit Name	Function
8 to 0	SGAPE108 to SGAPE100	SGAPE108 to SGAPE100 correspond to SGATERRIN40 to SGATERRIN32. 0: No action. The SGATERRINxx error is not generated. 1: A pseudo error is generated in the same way as SGATERRINxx.

Caution SGATERRIN18, SGATERRIN19, and SGATERRIN36 cannot be generated simultaneously with other pseudo errors.

(18) SGAEPCTL - SGA Error Pulse Output Control Register

This register is used to select the timer for the output of error signals while the SGA is in dynamic mode.

Access This register can be read/written in 8-bit units.

Address FF83 F020_H

Initial value 00_H

This register is initialized by a reset from any source.

7	6	5	4	3	2	1	0
0	0	0	0	0	0	0	SGATMSL
R	R	R	R	R	R	R	R/W

Table 10-28 SGAEPCTL Register Contents

Bit position	Bit Name	Function
0	SGATMSL	This bit selects the timer for the output of error signals while the SGA is in dynamic mode. 0: TAUB0 channel 15 is selected. 1: OST1 is selected.

Section 11 Data CRC Function A (DCRA)

This section contains a generic description of the data CRC function A (DCRA).

11.1 DCRA Features

Instances This product has the following number of instances of the data CRC function A.

Table 11-1 Instances of DCRA

Data CRC Function A	
Instance	2
Name	DCRAn

Instances index n Throughout this section, the individual instances of a data CRC function A is identified by the index "n" (n = 0, 1), for example, DCRAnCTL for the DCRAn control register.

Register addresses All DCRAn register addresses are given as address offsets to the individual base address <DCRAn_base0> or <DCRAn_base1>. The base addresses <DCRAn_base0> and <DCRAn_base1> of each DCRAn are listed in the following table.

Table 11-2 Register Base Addresses <DCRAn_base0> and <DCRAn_base1>

DCRAn	<DCRAn_base0> Address	<DCRAn_base1> Address
DCRA0	FFFF FA00 _H	FF83 6000 _H
DCRA1	FFFF FB00 _H	FF83 7000 _H

Clock supply All data CRC function A provide one clock input.

Table 11-3 DCRAn Clock Supply

DCRAn Instance	DCRAn Clock	Connected to
DCRAn	PCLK	Clock generator

11.2 Functional Overview

Features summary The data CRC function A can be used to verify or generate CRC protected data streams of arbitrary length and different bit widths.

- 32-bit Ethernet CRC (04C11DB7_H)

$$(X^{32} + X^{26} + X^{23} + X^{22} + X^{16} + X^{12} + X^{11} + X^{10} + X^8 + X^7 + X^5 + X^4 + X^2 + X^1 + 1)$$

XOR of the result for the generated CRC code and FFFFFFFF_H

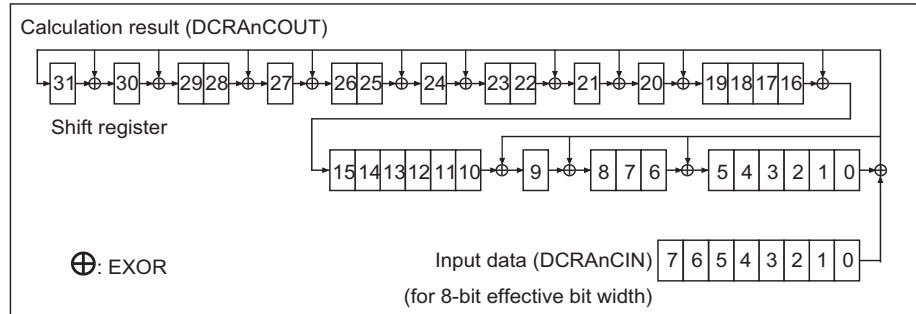

- 16-bit CCITT CRC (1021_H)

$$(X^{16} + X^{12} + X^5 + 1)$$

XOR of the result for the generated CRC code and 0000_H

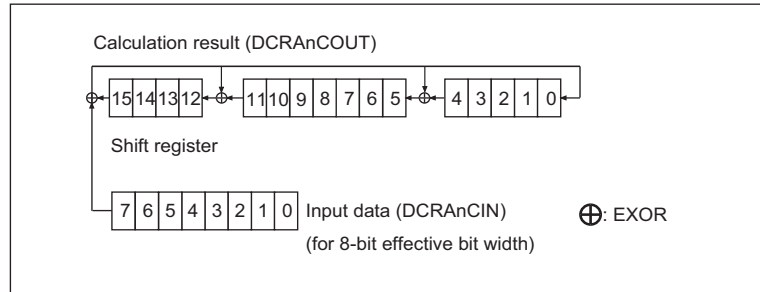

- CRC generation to an arbitrary data block length
- After initialization of the CRC input register, every write access to the CRC input register generates a new CRC according to the chosen polynomial and the result is stored in the CRC data register.

The following figure shows the block diagram of the data CRC function A.

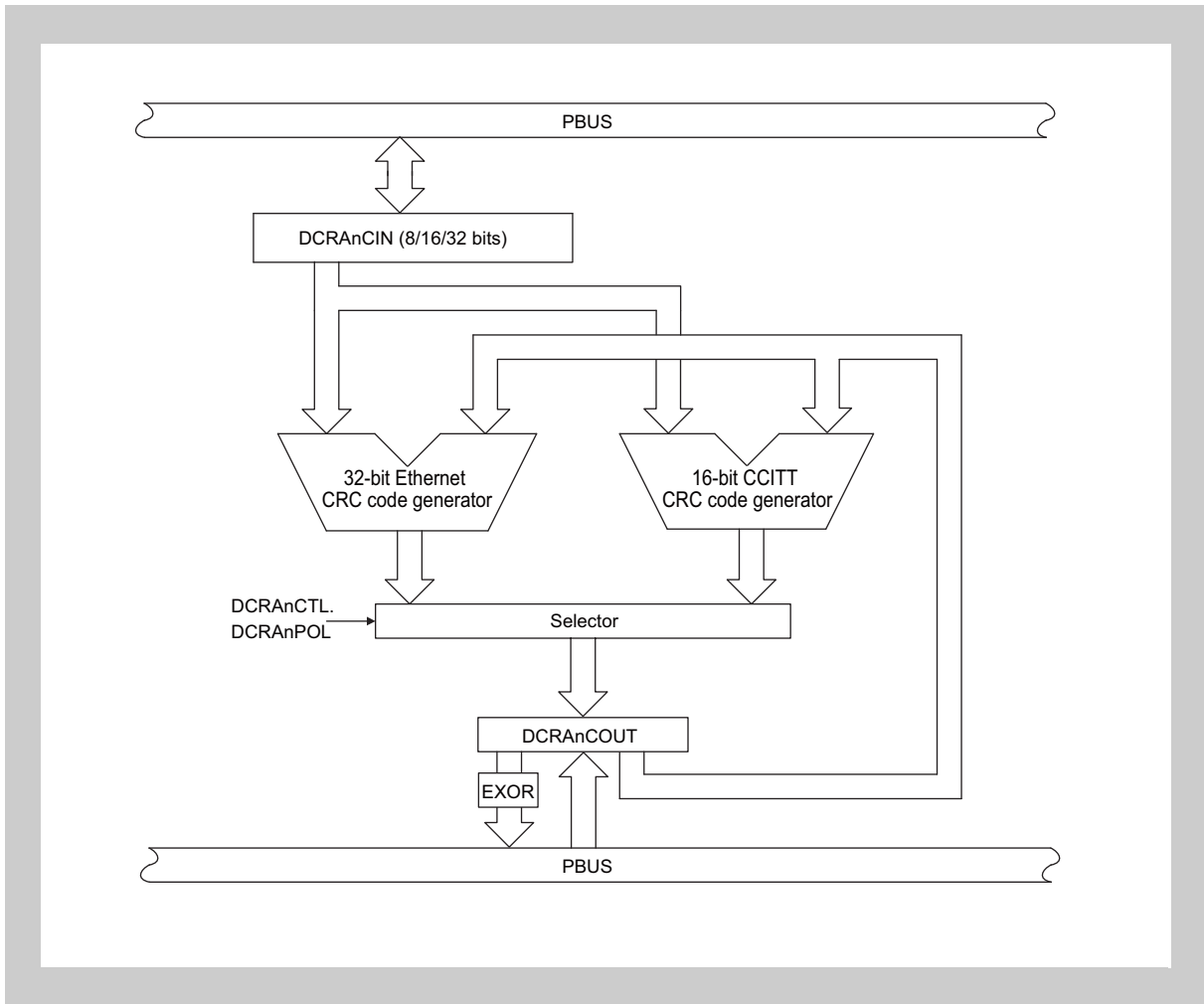

Figure 11-1 Block Diagram of Data CRC Function A

11.3 Functional Description

The data CRC function A generates a CRC (cyclic redundancy check) of an arbitrary data block length. The data is forwarded to the data CRC function in 8-, 16-, or 32-bit units. The CRC polynomial can either be selected for 32-bit Ethernet or 16-bit CCITT. The initial starting value must be set at the DCRAnCOUT register before the first write access to the CRC input register (DCRAnCIN) is performed.

The flow chart below shows the CRC generating procedure.

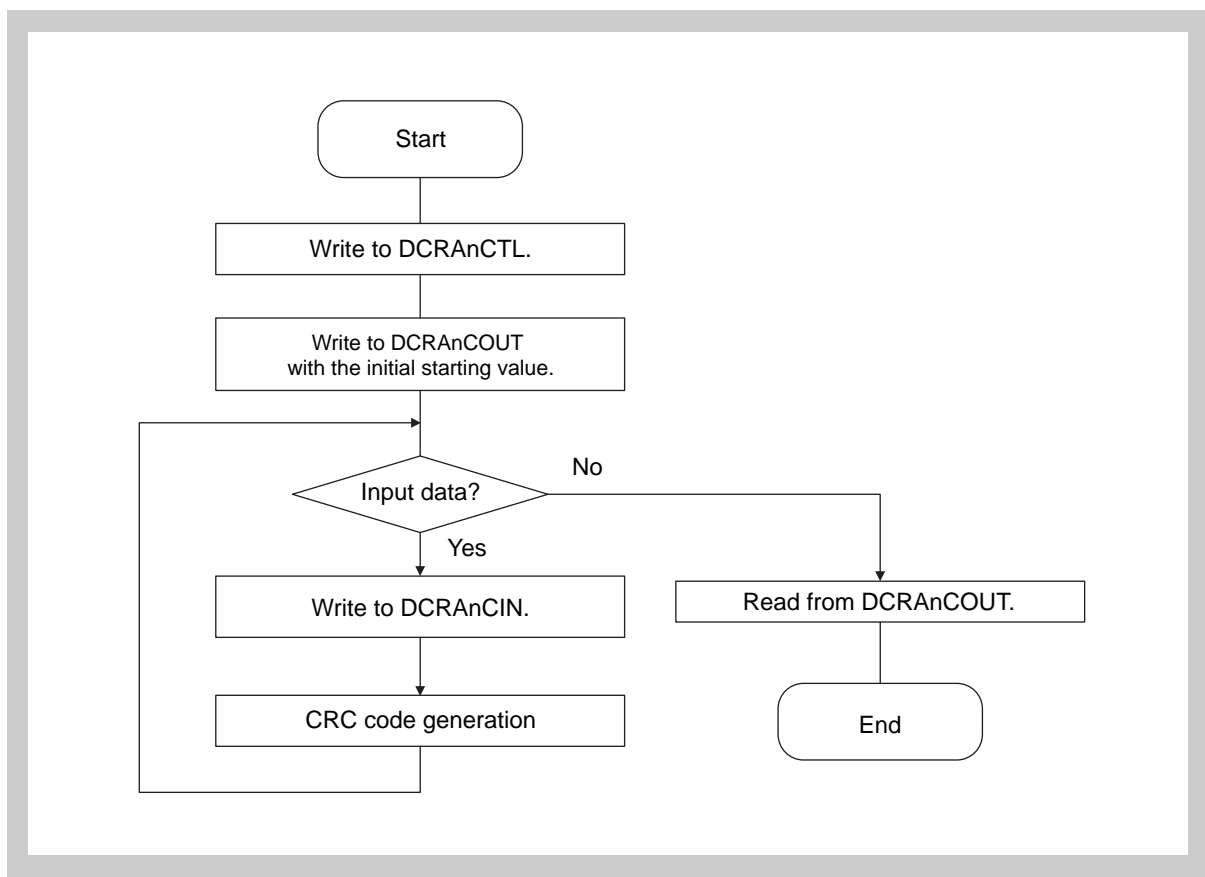

Figure 11-2 Data CRC Function A Flow Diagram

Note For the settings of the individual registers and points for caution regarding the settings, see Section 11.4.2, DCRA Registers Details.

11.4 Registers

This section contains a description of all registers of the DCRA.

11.4.1 DCRA Registers Overview

The DCRA is controlled and operated by the following registers.

Table 11-4 DCRA Registers Overview

Register Name	Symbol	Address
DATA-DCRA input register n	DCRAnCIN	<DCRAn_base0> + 00 _H
DATA-DCRA data register n	DCRAnCOUT	<DCRAn_base0> + 04 _H
DCRA control register n	DCRAnCTL	<DCRAn_base1> + 20 _H

11.4.2 DCRA Registers Details

(1) DCRAnCIN — CRC Input Register

This register holds the input data for the CRC calculation. The effective bit width used for CRC calculation must be set by DCRAnCTL.DCRAnISZ[1:0].

When data is written to this register, the CRC code is generated.

The CRC calculation is immediately started after the DCRAnCIN register is written. The DCRAnCOUT register must be initialized, with the initial starting value, before the first data of the data block is written to the DCRAnCIN register.

Byte order The byte order in DCRAnCIN depends on the selected CRC generating function.

- 32-bit Ethernet CRC polynomial generation (DCRAnCTL.DCRAnPOL = 0)
The byte order is LSB (least significant byte) first, means LSB at bit position 7...0 of the DCRAnCIN register.
- 16-bit CCITT CRC polynomial generation (DCRAnCTL.DCRAnPOL = 1)
The byte order is MSB (most significant byte) first, means MSB at bit position 7...0 of the DCRAnCIN register.

Access This register can be read/written in 32-bit units.

Address <DCRAn_base0> + 00_H

Initial value 0000 0000_H

This register is initialized by any reset sources.

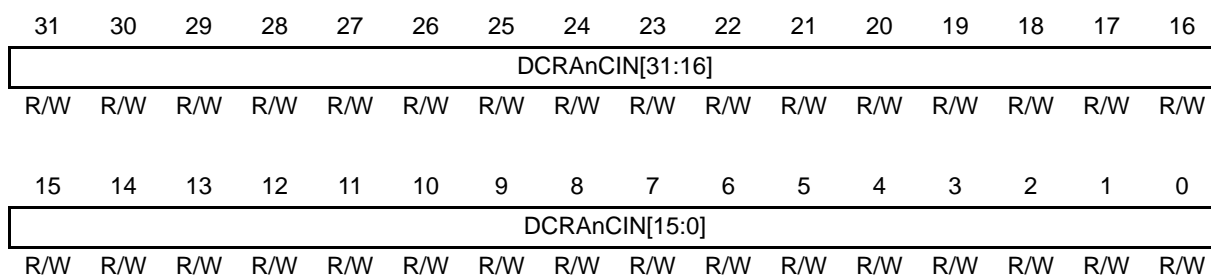

Table 11-5 DCRAnCIN Register Contents

Bit Position	Bit Name	Function
31 to 0	DCRAnCIN[31:0]	Input data for CRC calculation. The valid bits are: <ul style="list-style-type: none"> • For 32-bit effective bit width: DCRAnCIN[31:0] • For 16-bit effective bit width: DCRAnCIN[15:0] • For 8-bit effective bit width: DCRAnCIN[7:0]

(2) DCRAnCOUT — CRC Data Register

This register stores the result of the CRC code generated by the 32-bit Ethernet or 16-bit CCITT polynomial.

Access This register can be read/written in 32-bit units.

Address <DCRAn_base0> + 04_H

Initial value FFFF FFFF_H

This register is initialized by any reset sources.

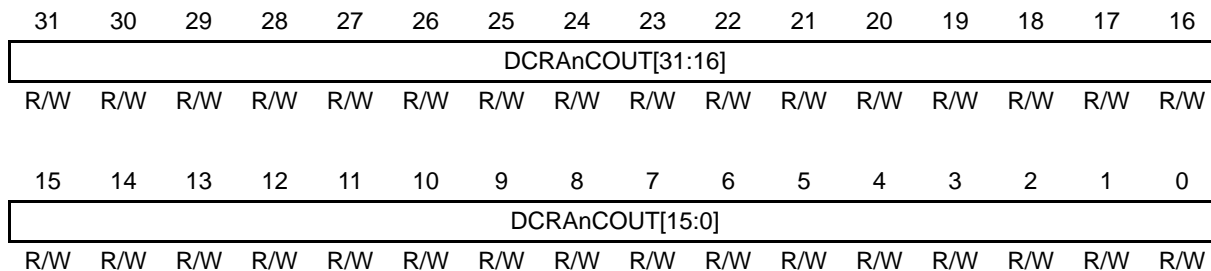

Table 11-6 DCRAnCOUT Register Contents

Bit Position	Bit Name	Function
31 to 0	DCRAnCOUT [31:0]	Result of the CRC code generation. When the 16-bit CCITT polynomial is enabled, bits 15 to 0 show the CRC result. The bits 31 to 16 are undefined. On reading these bits, the value read out is the XOR of the value described below and the DCRAnCOUT.DCRAnCOUT bits (this does not affect the DCRAnCOUT.DCRAnCOUT bits). <ul style="list-style-type: none"> • 32-bit Ethernet polynomial: FFFF FFFF_H • 16-bit CCITT CRC polynomial: 0000_H Therefore, for the 32-bit Ethernet polynomial, 0000 0000 _H is read from this register even in the initial state (FFFF FFFF _H).

Caution This register must be initialized with the starting value before the first data of the data block is written to the DCRAnCIN register.

(3) DCRAnCTL — CRC Control Register

This register controls the CRC generation process.

Access This register can be read/written in 8-bit units.

Address <DCRAn_base1> + 20_H

Initial value 00_H

This register is initialized by any reset sources.

7	6	5	4	3	2	1	0
0	0	0	0	0	DCRAnISZ[1:0]	DCRAnPOL	
R/W	R/W	R/W	R/W	R/W	R/W	R/W	R/W

Table 11-7 DCRAnCTL Register Contents

Bit Position	Bit Name	Function
2, 1	DCRAnISZ[1:0]	Specifies the CRC input bit width. 00: 32 bits (DCRAnCIN[31:0]) 01: 16 bits (DCRAnCIN[15:0]) 10: 8 bits (DCRAnCIN[7:0]) 11: Setting prohibited
0	DCRAnPOL	Specifies the CRC generating function. 0: 32-bit Ethernet CRC polynomial generation The byte order of the DCRAnCIN register is LSB (least significant byte) first, means LSB at bit position 7...0 of the DCRAnCIN register. 1: 16-bit CCITT CRC polynomial generation The byte order of the DCRAnCIN register is MSB (most significant byte) first, means MSB at bit position 7...0 of the DCRAnCIN register.

Note After changing the CRC generating function (DCRAnCTL.DCRAnPOL), the DCRAnCOUT register must be initialized.

Caution The CRC bit width (DCRAnCTL.DCRAnISZn) must be set according to the data block bit width. Switching the CRC bit width is not allowed during processing of a data block (a data block consists of N bytes, half words, or words). After the final CRC result is read from the DCRAnCOUT register, the bit width can be changed. In that case, the register should be set again according to Figure 11-2, Data CRC Function A Flow Diagram.

Section 12 Window Watchdog Timer A (WDTA)

This section contains a generic description of the window watchdog timer A (WDTA).

12.1 WDTA Features

Instances This product has one instance of the window watchdog timer A.

Table 12-1 Instances of WDTA

Window Watchdog Timer A	
Instances	1
Names	WDTAn

Instances index n Throughout this section, the individual instances of a window watchdog timer A are identified by the index “n” (n = 0), for example, WDTAnWDTE for the WDTAn enable register.

Register addresses All WDTAn register addresses are given as address offsets from the individual base address <WDTAn_base>.

The register base address of each WDTAn is listed in the following table.

Table 12-2 Register Base Addresses of WDTAn

WDTAn	<WDTAn_base> Addresses
WDTA0	FF80 6000 _H

Clock supply The window watchdog timer A provides WDTATCKI as the clock input. WDTATCKI is connected to the clock controller.

Table 12-3 Clock Supply of Window Watchdog Timer A

WDTAn	Clock Input Signal: WDTATCKI
WDTA0	Clock controller: WDTCLKI

Interrupts and reset outputs The interrupts and reset outputs of the WDTAn are listed in the table below.

Table 12-4 WDTA Interrupts and Reset Outputs

WDTAn Signal	Function	Connected to
WDTA0TRES	WDTA0 error reset	Reset controller: WDTA0RES Safety guardian: SGATERRIN3
WDTA0TNMI	WDTA0 error NMI	Interrupt controller: INTWDTA0NMI Safety guardian: SGATERRIN3
WDTA0TIT	WDTA0 75% interrupt	Interrupt controller: INTWDTA0

Caution The WDTA0TNMI signal is output in synchronization with the counter clock (WDTATCKI). Therefore, when the WDTA0TNMI signal is asserted, the SGAmESSTR0.SGAmSSE003 must be cleared after one cycle of WDTATCKI.

12.2 Functional Overview

Features summary The WDTA has the following functions.

- Operation in response to error detection is selectable.
 - Generation of NMI request (WDTAnTNMI) on error detection
 - Generation of reset (WDTAnTRES) on error detection
- Interrupt request generation at 75% of the counter overflow value
- Window function

The following figure shows the main components of the WDTA.

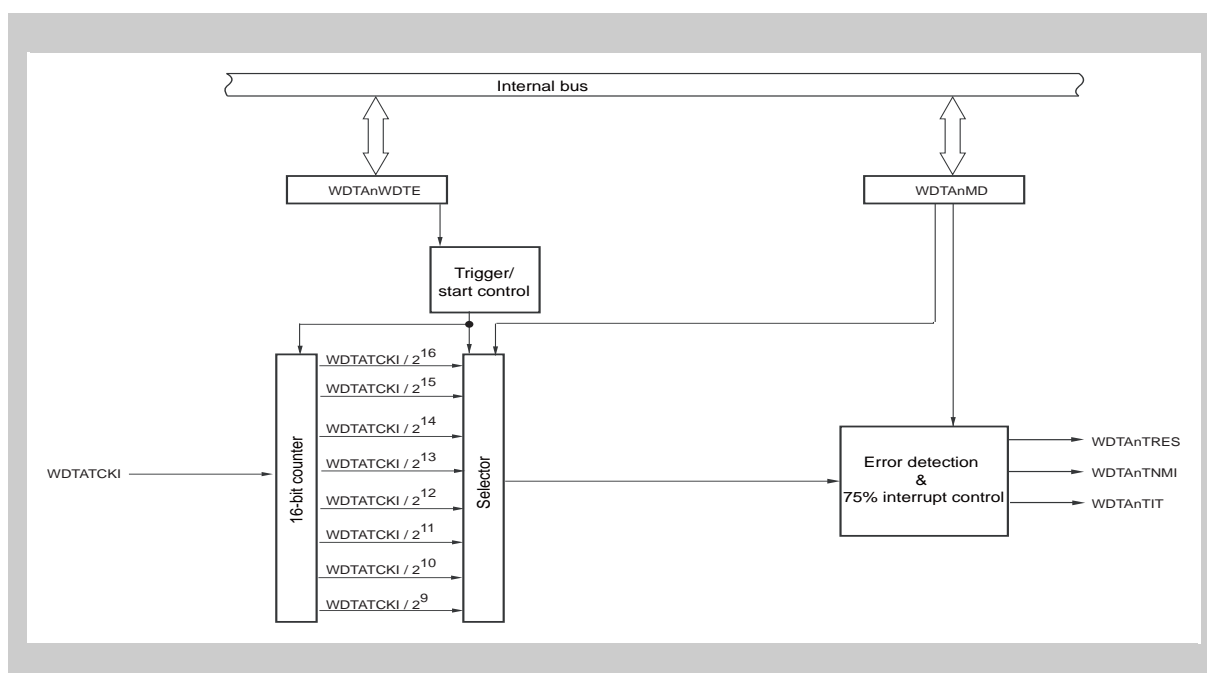

Figure 12-1 Block Diagram of the WDTA

12.3 Functional Description

The WDTA generates a reset or a non-maskable interrupt if the 16-bit counter overflows or if any other error condition is fulfilled. For a description of all error conditions, refer to Section 12.3.3, Error Detection.

The counter is cleared and restarted every time a WDTA trigger occurs in the window-open period. Refer to Section 12.3.2, WDTA Trigger, and Section 12.3.5, Window Function, for details.

At 75% of the counter overflow value, the WDTA can generate an interrupt request (WDTAnTIT). Refer to section Section 12.3.4, 75% Interrupt Output, for details.

12.3.1 WDTA after Reset Release

The counter value remains 0000_H after reset release.

The counter is started with the first WDTA trigger.

(1) WDTA Settings after Reset Release

The WDTA settings are as follows after reset release.

Function	Setting	Remarks
Overflow time	$2^{16}/\text{WDTATCKI}$	
75% interrupt mode	Enabled	
Error mode	Reset mode	Any error condition before the first trigger generates a reset.
Window-open period	100%	

Change WDTA settings

After the first trigger, the WDTA continues according to the settings of the watchdog timer mode register (WDTAnMD).

To change the WDTA settings, WDTAnMD must be written before the first trigger. Changing the value of WDTAnMD after the first trigger leads to an error condition.

If the value in WDTAnMD is not changed before the first trigger, the WDTA will operate with the initial value of WDTAnMD.

The settings of WDTAnMD apply after the first trigger.

WDTA start timing The WDTA start timing and the changes to the WDTA settings are illustrated in the following figure.

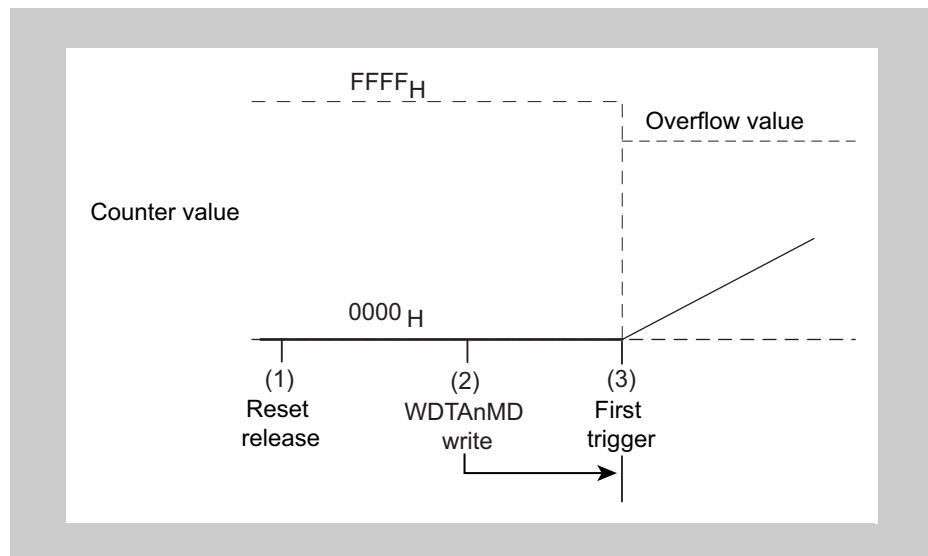

Figure 12-2 Timing Diagram of WDTA Start

The timing diagram above shows the following.

1. After reset release, the counter value remains 0000_H until the first trigger is generated.
2. WDTAnMD should be written before the first trigger is generated. However, the settings are not applied immediately.
3. The counter starts at the first trigger.

The overflow value and other settings specified in WDTAnMD are applied.

12.3.2 WDTA Trigger

The WDTA trigger has the following functions.

- Starting the WDTA by the first trigger after release from reset (i.e. the first software trigger to start counting).
- Counter re-start trigger to keep the counter from overflowing.

The WDTA can be triggered by writing a fixed activation code to the trigger register (see Table 12-5, Trigger Register and Activation Code).

Table 12-5 Trigger Register and Activation Code

Type of Activation Code	Trigger Register	Activation Code
Fixed	WDTAnWDTE	AC _H

12.3.3 Error Detection

The conditions for error detection are:

- Overflow time is exceeded (counter overflow)
- Wrong activation code is written to the trigger register
- Writing to the trigger register outside the open window.
- Illegal update of the watchdog timer mode register (WDTAnMD)
 - Writing a new value to WDTAnMD after the first trigger leads to an error detection.
 - Writing the same value to WDTAnMD after the first trigger does not lead to an error detection.

Error mode When an error is detected, either an NMI request (WDTAnTNMI) or a reset (WDTAnTRES) is generated.

WDTAnMD.WDTAnERM selects the error mode:

- WDTAnMD.WDTAnERM = 0: NMI mode
- WDTAnMD.WDTAnERM = 1: Reset mode

The following figure shows the reset or NMI request generation when the counter overflows.

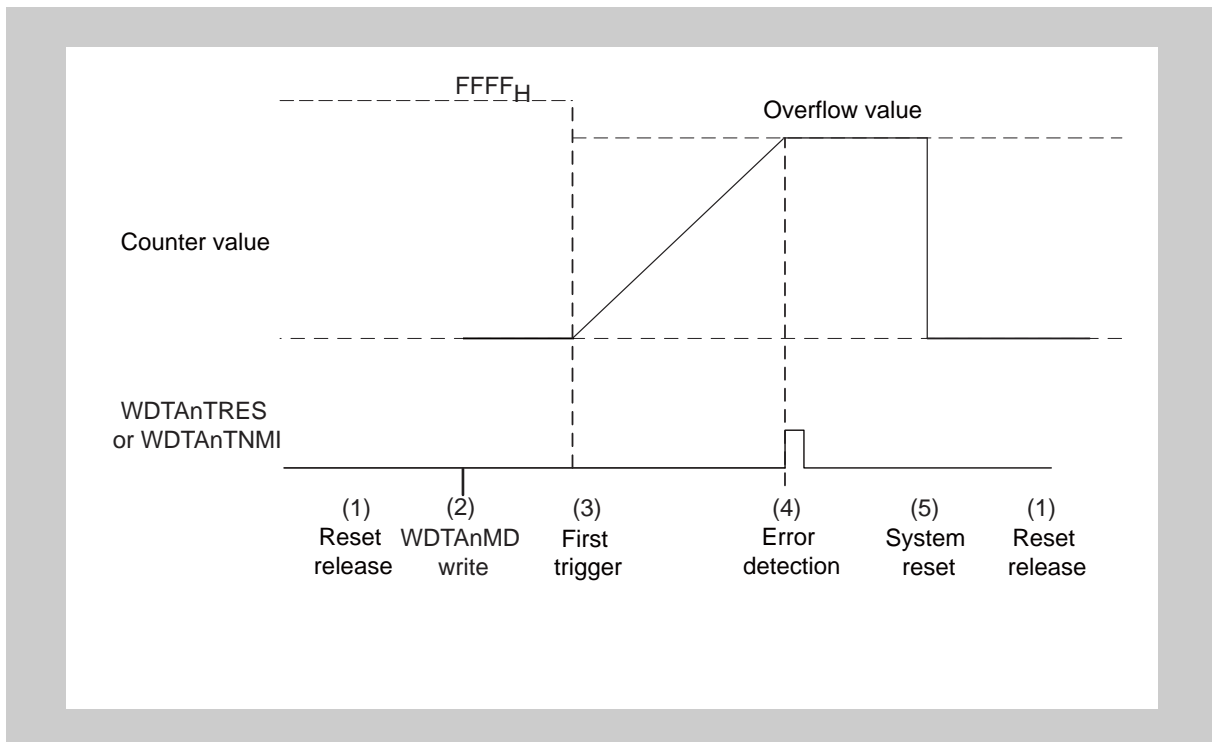

Figure 12-3 Timing Diagram of WDTA NMI Request or Reset Generation

The timing diagram above shows the following.

1. After reset release, the counter value remains 0000_H until the first trigger is generated.
2. WDTAnMD should be written before the first trigger is generated. However, the settings are not applied immediately.
3. The counter starts at the first trigger.
The overflow value and other settings specified in WDTAnMD are applied.
4. When the counter overflows, an error is detected. Depending on the error mode, either interrupt request WDTAnTnMI or reset WDTAnTRES is generated.

The counter value remains until the system reset is performed.

5. When the system is reset, the counter is cleared.

12.3.4 75% Interrupt Output

When the counter reaches 75% of the overflow value, the interrupt request WDTAnTIT is generated.

The WDTAnMD.WDTAnWIE register enables/disables this function.

The following figure shows the 75% interrupt request generation with the following conditions:

- Count clock changes after the first trigger

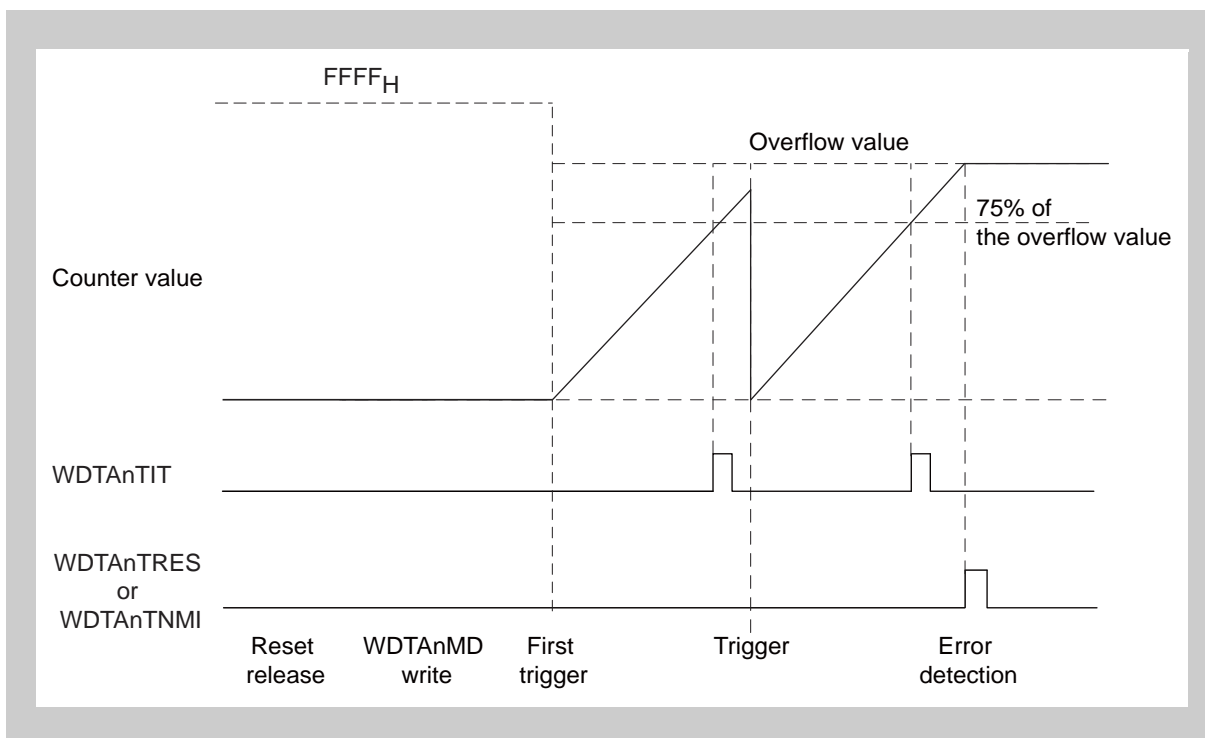

Figure 12-4 Timing Diagram of WDTA 75% Interrupt Output

12.3.5 Window Function

When the window-open period is set to less than 100%, an error is detected if the trigger occurs outside the open window.

The definition of the window-open period differs before and after the first trigger.

- After reset release, the window-open period is 100%.
Bits WDTAnMD.WDTAnWS[1:0] are not applied.
- After the first trigger, the window-open period is specified by bits WDTAnMD.WDTAnWS[1:0].

The following figure shows WDTA operation with a window-open period of 25%.

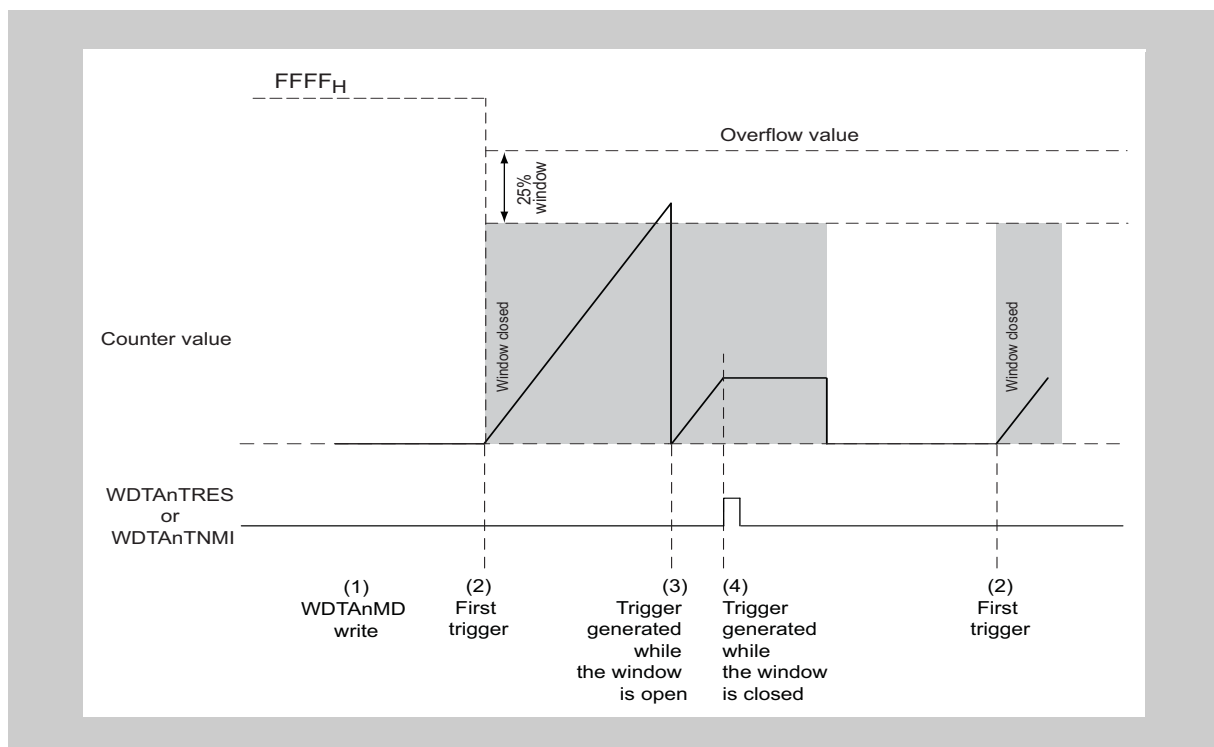

Figure 12-5 Timing Diagram of WDTA Window Function

The timing diagram above shows the following.

1. The operating-mode settings in WDTAnMD should be made before the first trigger is generated. However, the settings are not applied immediately.
2. The window-open period is fixed to 100% for the first trigger. After the first trigger, the overflow value and other settings specified in WDTAnMD are applied.
3. A trigger that occurs in the window-open period does not generate an error.
4. A trigger that occurs in the closed window generates a WDTAnTNMI request or a WDTAnTRES reset, depending on the selected operating mode.

12.4 Registers

This section contains a description of all registers of the WDTA.

12.4.1 WDTA Registers Overview

The WDTA is controlled and operated by the following registers.

Table 12-6 WDTA Register Overview

Register Name	Symbol	Address
WDTA enable register	WDTAnWDTE	<WDTAn_base> + 0000 _H
WDTA mode register	WDTAnMD	<WDTAn_base> + 000C _H

12.4.2 WDTA Registers Details

(1) WDTA Enable Register (WDTAnWDTE)

This register is the WDTA start control and trigger register.

WDTA trigger Writing AC_H to this register restarts the counter. Refer to Section 12.3.2, WDTA Trigger, for details.

Do not write a value other than AC_H. Otherwise, an error is detected.

Access This register can be read/written in 8-bit units.

Address <WDTAn_base> + 0000_H

Initial value 2C_H

This register is initialized by any reset sources.

7	6	5	4	3	2	1	0
WDTAn RUN	0	1	0	1	1	0	0
R/W	R/W	R/W	R/W	R/W	R/W	R/W	R/W

Table 12-7 WDTAnWDTE Register Contents

Bit Position	Bit Name	Function
7	WDTAnRUN	Enables/disables the WDTAn. 0: WDTAn disable 1: WDTAn enabled Since the WDTA cannot be stopped once it was started, this bit can only be cleared by a reset.

(2) WDTA Mode Register (WDTAnMD)

This register specifies the overflow time, the 75% interrupt output mode, the error mode, and the window-open period.

It can be updated only once after reset release and before the first trigger. The updated value is effective after the next WDTA trigger.

Updating this register after the WDTA has been started leads to error detection, but the read value of this register can be written without generating an error.

Access This register can be read/written in 8-bit units.

Address <WDTAn_base> + 000C_H

Initial value 7F_H

This register is initialized by any reset sources.

7	6	5	4	3	2	1	0
0	WDTAnOVF[2:0]			WDTAnWIE	WDTAnERM	WDTAnWS[1:0]	
R*	R/W	R/W	R/W	R/W	R/W	R/W	R/W

* Writing to this bit is ignored, reading returns 0.

Table 12-8 WDTAnMD Register Contents

Bit Position	Bit Name	Function																																				
6 to 4	WDTAnOVF[2:0]	Selects the overflow time. <table border="1" style="margin-top: 10px;"> <thead> <tr> <th>WDTAnOVF 2</th> <th>WDTAnOVF 1</th> <th>WDTAnOVF 0</th> <th>Overflow Time</th> </tr> </thead> <tbody> <tr><td>0</td><td>0</td><td>0</td><td>2.048 ms</td></tr> <tr><td>0</td><td>0</td><td>1</td><td>4.096 ms</td></tr> <tr><td>0</td><td>1</td><td>0</td><td>8.192 ms</td></tr> <tr><td>0</td><td>1</td><td>1</td><td>16.384 ms</td></tr> <tr><td>1</td><td>0</td><td>0</td><td>32.768 ms</td></tr> <tr><td>1</td><td>0</td><td>1</td><td>65.536 ms</td></tr> <tr><td>1</td><td>1</td><td>0</td><td>131.072 ms</td></tr> <tr><td>1</td><td>1</td><td>1</td><td>262.144 ms</td></tr> </tbody> </table>	WDTAnOVF 2	WDTAnOVF 1	WDTAnOVF 0	Overflow Time	0	0	0	2.048 ms	0	0	1	4.096 ms	0	1	0	8.192 ms	0	1	1	16.384 ms	1	0	0	32.768 ms	1	0	1	65.536 ms	1	1	0	131.072 ms	1	1	1	262.144 ms
WDTAnOVF 2	WDTAnOVF 1	WDTAnOVF 0	Overflow Time																																			
0	0	0	2.048 ms																																			
0	0	1	4.096 ms																																			
0	1	0	8.192 ms																																			
0	1	1	16.384 ms																																			
1	0	0	32.768 ms																																			
1	0	1	65.536 ms																																			
1	1	0	131.072 ms																																			
1	1	1	262.144 ms																																			
3	WDTAnWIE	Enables/disables the 75% interrupt request WDTAnTIT. 0: WDTAnTIT disabled 1: WDTAnTIT enabled																																				
2	WDTAnERM	Specifies the error mode. 0: NMI request mode 1: Reset mode																																				
1, 0	WDTAnWS[1:0]	Selects the period over which the window is open. <table border="1" style="margin-top: 10px;"> <thead> <tr> <th>WDTAnWS1</th> <th>WDTAnWS0</th> <th>Window-Open Period</th> </tr> </thead> <tbody> <tr><td>0</td><td>0</td><td>25%</td></tr> <tr><td>0</td><td>1</td><td>50%</td></tr> <tr><td>1</td><td>0</td><td>75%</td></tr> <tr><td>1</td><td>1</td><td>100%</td></tr> </tbody> </table>	WDTAnWS1	WDTAnWS0	Window-Open Period	0	0	25%	0	1	50%	1	0	75%	1	1	100%																					
WDTAnWS1	WDTAnWS0	Window-Open Period																																				
0	0	25%																																				
0	1	50%																																				
1	0	75%																																				
1	1	100%																																				

Section 13 Timer Array Unit B (TAUB)

This section contains a generic description of the Timer Array Unit B (TAUB).

The first section describes all V850E2/PG4-L specific properties, such as instances, register base addresses, input/output signal names, etc. The subsequent sections describe the features that apply to all implementations.

13.1 TAUB Features

Instances This microcontroller has following number of instances of the Timer Array Unit B.

Table 13-1 Instance of TAUB

TAUB	
Instance	1
Name	TAUB0

Instances index n Throughout this section, each of the TAUB instances is identified by "n" (n = 0), such as TAUBn channel output mode register (TAUBnTOM).

Channels index m TAUB has 16 channels. Throughout this section, each channel is identified by "m" (m = 0 to 15). Thus, a certain channel is denoted as CHm. The even numbered channels (m = 0, 2, 4, 6, 8, 10, 12, 14) are denoted as CHm_even. The odd numbered channels (m = 1, 3, 5, 7, 9, 11, 13, 15) are denoted as CHm_odd.

Register addresses All TAUBn register addresses are given as address offsets to the individual base addresses <TAUBn_base0>, <TAUBn_base1>. The base address of each TAUBn is listed in the following table.

Table 13-2 Register Base Address <TAUBn_base0> and <TAUBn_base1>

TAUBn Instance	<TAUBn_base0> Address	<TAUBn_base1> Address
TAUB0	FF80 8000 _H	FFFF C400 _H

Clock supply All Timer Array Units B provide one clock input.

Table 13-3 TAUBn Clock Supply

TAUBn Instance	TAUBn Clock	Connected to
TAUB0	PCLK	Clock Controller CKSCLK_006

Interrupts and DMA The Timer Array Unit B can generate the following interrupt and DMA request.

Table 13-4 TAUBn Interrupt and DMA Requests

TAUBn Signals	Function	Connected to
TAUB0:		
INTTAUB010	Channel0 interrupt	Interrupt controller INTTAUB010 DMA controller trigger 27
INTTAUB011	Channel1 interrupt	Interrupt controller INTTAUB011 DMA controller trigger 28
INTTAUB012	Channel2 interrupt	Interrupt controller INTTAUB012 DMA controller trigger 29
INTTAUB013	Channel3 interrupt	Interrupt controller INTTAUB013 DMA controller trigger 30
INTTAUB014	Channel4 interrupt	Interrupt controller INTTAUB014 DMA controller trigger 31
INTTAUB015	Channel5 interrupt	Interrupt controller INTTAUB015 DMA controller trigger 32
INTTAUB016	Channel6 interrupt	Interrupt controller INTTAUB016 DMA controller trigger 33
INTTAUB017	Channel7 interrupt	Interrupt controller INTTAUB017 DMA controller trigger 34
INTTAUB018	Channel8 interrupt	Interrupt controller INTTAUB018 DMA controller trigger 35
INTTAUB019	Channel9 interrupt	Interrupt controller INTTAUB019 DMA controller trigger 36
INTTAUB0110	Channel10 interrupt	Interrupt controller INTTAUB0110 DMA controller trigger 37
INTTAUB0111	Channel11 interrupt	Interrupt controller INTTAUB0111 DMA controller trigger 38
INTTAUB0112	Channel12 interrupt	Interrupt controller INTTAUB0112 DMA controller trigger 39
INTTAUB0113	Channel13 interrupt	Interrupt controller INTTAUB0113 DMA controller trigger 40
INTTAUB0114	Channel14 interrupt	Interrupt controller INTTAUB0114 DMA controller trigger 41
INTTAUB0115	Channel15 interrupt	Interrupt controller INTTAUB0115 DMA controller trigger 42

TAUB H/W reset The Time Array Units B and their registers are initialized by the following reset signal.

Table 13-5 TAUBn Reset Signal

TAUBn	Reset Signal
TAUBn	Reset Controller SYSRES

I/O signals The I/O signals of the Timer Array Unit B are listed in the table below.

Table 13-6 TAUBn I/O Signal

TAUB Signal	Function	Connected to
TAUB0TTIN0 to TAUB0TTIN15	Channel 0 to 15 input	Port TAUB0I0 to TAUB0I15
TAUB0TTOUT0 to TAUB0TTOUT15	Channel 0 to 15 output	Port TAUB0O0 to TAUB0O15

TAUBn interrupts and I/O signals are illustrated below.

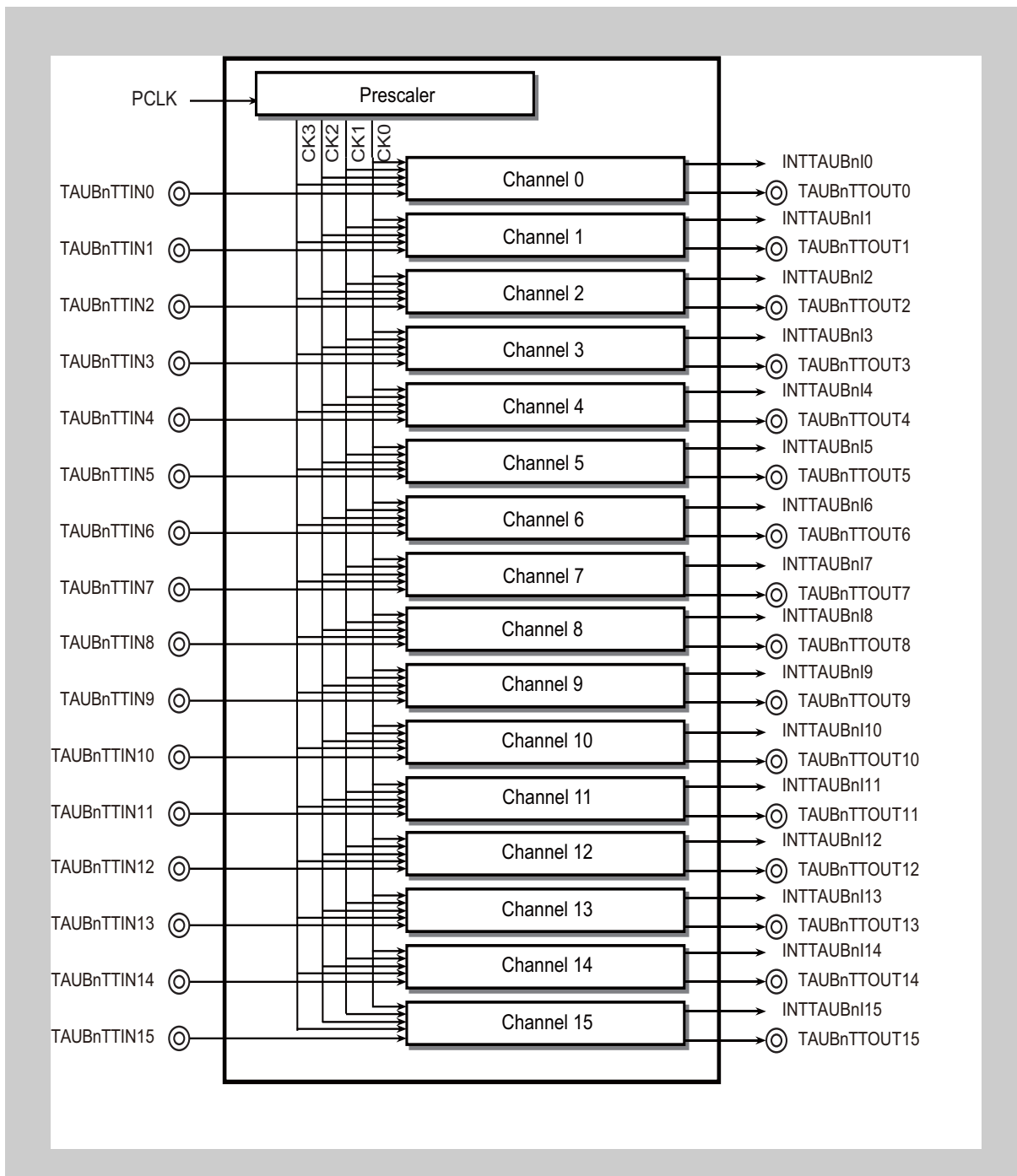

Figure 13-1 TAUB I/O and Interrupt Signals

13.2 Functional Overview

Features summary TAUB has the following functions:

- 16 channels
- 16-bit counter and 16-bit data register per channel
- Independent channel operation
- Synchronous channel operation (master and slave operations)
- Generation of different types of output signals
- Counter can be triggered by external signal
- Interrupt generation

The following figure shows the main components of the TAUB.

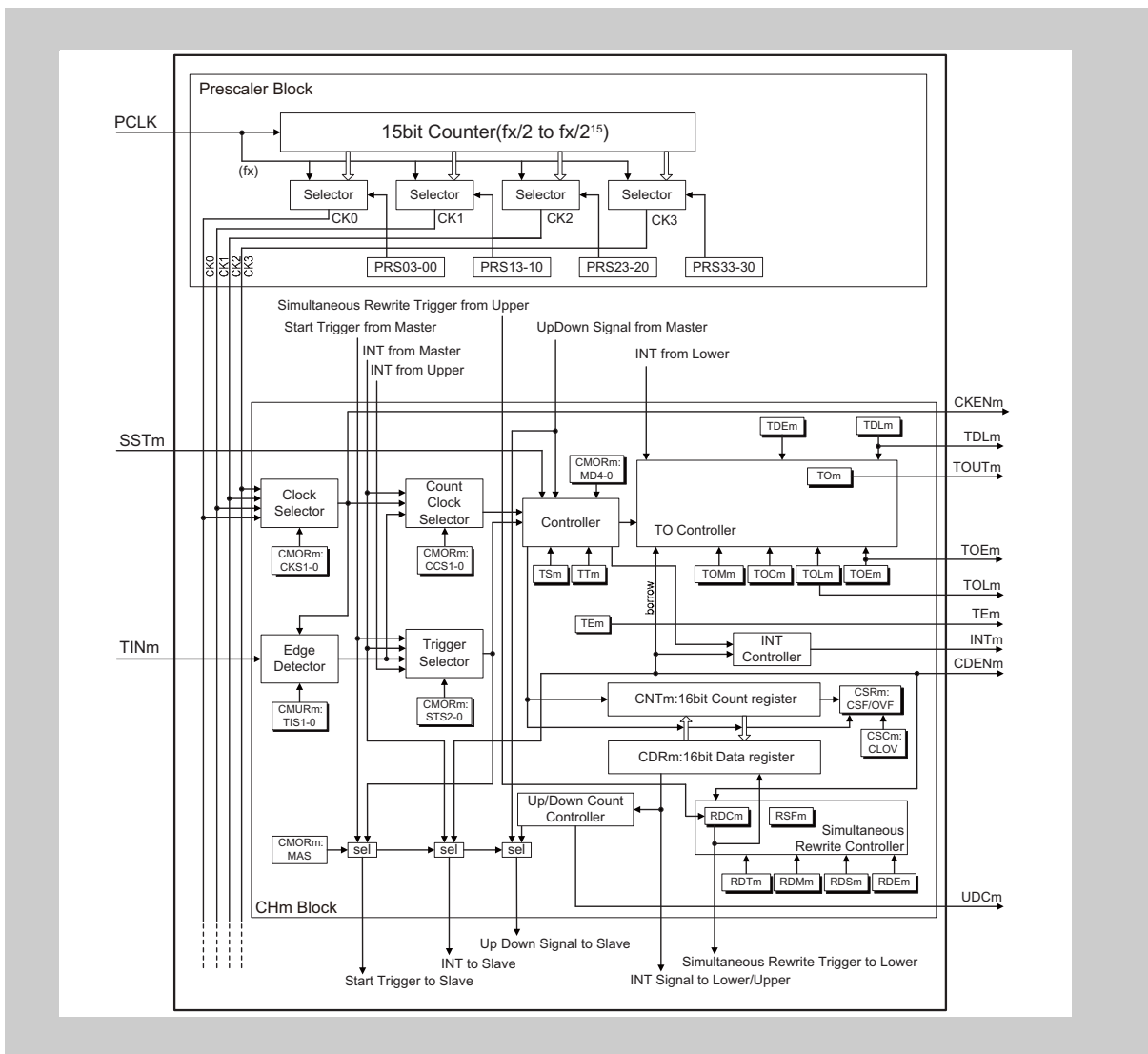

Figure 13-2 Block Diagram of the TAUB

The prefix "TAUBn" has been omitted from the register names for the sake of brevity in the above figure.

13.2.1 Terms

In this section, the following terms are used.

- Independent/synchronous channel operation

Independent or synchronous channel operation describes the dependency of channels on each other:

- If a channel operates independent of all other channels, this is called independent channel operation.
- If a channel operates depending on other channels, this is called synchronous channel operation.

- Channel group

In synchronous channel operation, all channels that depend on each other are referred to as a "channel group".

A channel group has one master channel and one or more slave channels.

- Operating mode

An operating mode can be selected for every channel m . The operating mode defines the basic operation and features of a channel.

In synchronous channel operation, every channel in a channel group can operate in a different operating mode.

Examples are "capture mode", "event count mode", and "interval timer mode".

- Channel output mode

The channel output mode defines the operation of $TAUBnTTOUm$:

- of a single channel (independent output operation) or
- of all channels in a channel group (synchronous output operation).

Examples are "independent channel output mode 1" and "synchronous channel output mode 2 with dead time output".

- Channel operation function

The channel operation function defines the complete function and all features:

- of a single channel (independent channel operation) or
- of all channels in a channel group (synchronous channel operation).

- Upper and lower channels

Upper and lower channels are defined below.

- Upper channel: A channel with a lower channel number
- Lower channel: A channel with a higher channel number

Example: For channel 5, channel 3 is an upper channel and channel 9 is a lower channel.

13.3 Functional Description

The Timer Array Unit B performs various count or timer operations and outputs a signal which depends on the result of the operation. It contains one prescaler block for count clock generation and 16 channels, each equipped with a 16 bit counter TAUBnCNTm and a 16-bit data register TAUBnCDRm to hold the start or compare value of the counter.

It also contains several control and status registers.

- Independent and synchronous operation** Every channel can operate in different operating modes, either independently or in combination with other channels (synchronously); for example, in a combination of one master and one or more slave channels, slave channels depend on the master channel.
- When a channel is operated independently, its operating mode and functions are not affected by those of other channels. When a channel is operated synchronously it is either a master or a slave. A master channel can have multiple slaves, and the state of one channel affects that of the other channels. For example, one channel can be used to control the count start timing or reset timing of others.
- The following describes the functional blocks.
- Prescaler block** The prescaler block provides up to 4 clock signals (CK0 to CK3) that can be used as count clocks for all channels.
- Plescaler outputs CK0 to CK2 are derived from PCLK by a configurable prescaler division factor of 2^0 to 2^{15} . The fourth prescaler output CK3 can be adjusted more precisely by an additional division factor that is not a power of 2.
- Count clock selection** For every channel, the count clock selector selects which of the following is used as a clock source:
- One of the prescaler outputs CK0 to CK3 (selected by the clock selector)
 - INTTAUBnIm from master channel
 - Valid edge of TAUBnTTINm input signal
- Controller** The controller controls the main operations of the counter:
- Operating mode (selected by TAUBnCMORm.TAUBnMD[4:0] bits)
 - Counter start enable (TAUBnTS.TAUBnTSm) and counter stop (TAUBnTT.TAUBnTTm)
When counter start is enabled, status flag TAUBnTE.TAUBnTEm is set.
 - Count direction (can be controlled by master channel)

-
- Trigger selector** Depending on the selected operating mode, the counter starts automatically when it is enabled (TAUBnTE.TAUBnTEm = 1), or it waits for an external start trigger signal. Any of the following signals can be used as a start trigger.
- Synchronous channel start trigger input TAUBnTSSTm
Valid edge of TAUBnTTINm input
 - INTTAUBnIm from master or any upper channel
 - Up/down output trigger signal of master channel
 - Dead-time output signal of TAUBnTTOUTm generation unit
- Simultaneous rewrite controller** Simultaneous rewrite control is a special function that can be used in synchronous operating modes. The data registers (TAUBnCDRm) of all channels in a channel group can be rewritten at any time. The simultaneous rewrite controller ensures that new data register values of all channels become effective at the same time.
- TAUBnTO controller** The output control of every channel enables the generation of various output signals such as PWM signals or triangular wave signals.
- Signals** The TAUB has multiple I/O signals. Refer to Table 13-6, TAUBn I/O Signal.

13.3.1 Functional List of Timer Operations

This timer provides the following functions by operating each channel independently or by combining multiple channels.

Table 13-7 Functional List of TAUB Operations

Function of Independent Operation	Function of Synchronous Operation
Independent channel operation functions	Synchronous channel operation functions
Interval timer function	PWM output function
TAUBnTTINm input interval timer function	Delay pulse output function
One-pulse output function	AD conversion trigger output function type1
Independent channel signal measurement functions	Synchronous PWM signal functions triggered by an external signal
TAUBnTTINm input pulse interval measurement function	One-shot pulse output function
TAUBnTTINm input signal width measurement function	Synchronous triangle PWM output functions
TAUBnTTINm input period count detection function	Triangle PWM output function
TAUBnTTINm input pulse interval judgment function	Triangle PWM output function with dead time
TAUBnTTINm input signal width judgment function	AD conversion trigger output function type 2
Independent channel simultaneous rewrite function	
Simultaneous rewrite trigger generation function type 1	
Other independent channel functions	
External event count function	
Clock divide function	
TAUBnTTINm input position detection function	

13.4 General Operating Procedures

The following lists the general operation procedures for the TAUBn.

After reset release, the operation of each channel is stopped. Clock supply is started and writing to each register is enabled. The control register of TAUBnTTOUTm is also initialized and outputs a low level.

1. Set the TAUBnTPS and TAUBnBRS registers to specify the clock frequency of CK0 to CK3.
2. Configure the desired TAUBn function:
 - Set the operating mode
 - Set the channel output mode
 - Set any other control bits
3. Enable the counter by setting the TAUBnTS.TAUBnTSM bit to 1.

The counter starts to count immediately, or when an appropriate trigger is detected, according to bit settings.
4. If desired during counting, and if possible for the configured function, stop the counter or perform a forced restart operation.
5. To stop the function, set the TAUBnTT.TAUBnTTm bit to 1.

Note For details on necessary control bits and the operations of individual functions, see Section 13.12, Independent Channel Operation Functions, and Section 13.17, Synchronous Channel Operation Functions.

13.5 Operation Modes

The TAUB contains 12 operating modes.

One operating mode can be set for each channel, which is specified using the TAUBnCMORm.TAUBnMD[4:0] bits.

Note Some of the registers and bits are fixed and some are user-selectable depending on the operation function.

For details on the registers and bit settings, see the corresponding sections of operational functions.

13.6 Concepts of Synchronous Channel Operation

In synchronous channel operation, multiple channels depend on each other, or are affected by changes in another channel. Therefore, several rules apply for the use of synchronous channel functions. These rules are detailed in Section 13.6.1, Rules.

Two special features for synchronous channel operation are detailed in the following sections:

- Section 13.6.2, Simultaneous Start and Stop of Synchronous Channel Counters
- Section 13.7, Simultaneous Rewrite

13.6.1 Rules

- Number of masters and slaves**
- Only even channels (CH0, CH2, CH4,...) can be set as master channels. Any channel apart from CH0 can be set as a slave channel
 - Only channels lower than the master channel can be set as slave channels, and several slave channels can be set for one master channel.
Example: If CH2 is a master channel, channels (CH3, CH4, CH5,...) following CH3 can be set as slave channels.
 - If two master channels are used, slave channels cannot cross the master channels.
Example: If CH0 and CH4 are master channels, CH1 to CH3 can be set as slave channels for CH0, but CH5 to CH15 cannot.
- Operation clock**
- The same operation clock must be set for the slave channel and the master channel. This is achieved using the TAUBnCMORm.TAUBnCKS[1:0] bits of the slave and master channel.

The basic concepts of master and slave usage and the count clocks are illustrated in the following figure.

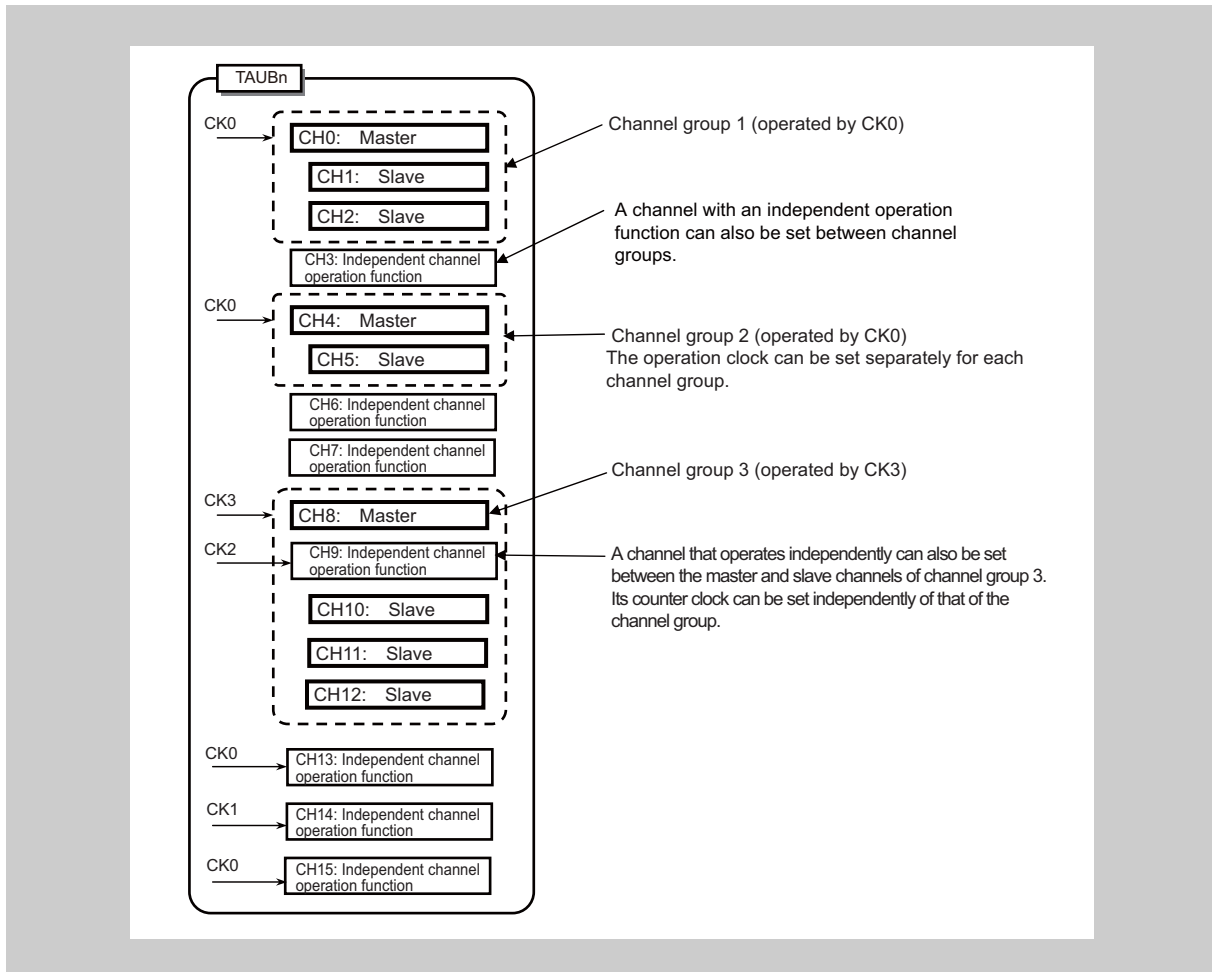

Figure 13-3 Grouping of Channels and Assignment of Operation Clocks

Control trigger signal for master/salve channels

- Master channels can output control trigger signals to slave channels.
- Slave channels can use control trigger signals from master channels but cannot output control trigger signals for their own to lower channels.
- Master channels cannot use control trigger signals from upper master channels.

13.6.2 Simultaneous Start and Stop of Synchronous Channel Counters

Channels that are operated synchronously can be started and stopped simultaneously within the same unit and between the units.

(1) Simultaneous start and stop within the same unit

- To simultaneously start synchronized channels, the TAUBnTS.TAUBnTSM bits of the channels should be set at the same time.
- To simultaneously stop synchronized channels, the TAUBnTT.TAUBnTTM bits of the channels should be set at the same time.

Setting to the TAUBnTS.TAUBnTSM bits to 1 also sets the corresponding TAUBnTE.TAUBnTEM bits to 1, enabling counting. The count start timing depends on operating mode.

(2) Simultaneous start between the units

Counters in different units can also be started simultaneously if the corresponding counters are enabled before receiving the simultaneous trigger signal.

13.7 Simultaneous Rewrite

13.7.1 Overview

Simultaneous rewrite describes the ability to change the compare/start value and the output logic of multiple channels at the same time.

The corresponding data registers and control registers (TAUBnCDRm and TAUBnTOLm) can nevertheless be written at any time. The new value does not affect the counter operation or the output signal until simultaneous rewrite is triggered.

Simultaneous rewrite can be triggered by:

- The counter on the master channel or upper channel (depending on the selected operating mode) reaching a certain value
- INTTAUBnIm being issued on the upper channel specified by TAUBnRDC.TAUBnRDCm

There are three methods for simultaneous rewrite. These are listed in the following table, along with how to specify them and when they cause simultaneous rewrite to be triggered.

Table 13-8 Simultaneous Rewrite Methods and Trigger Timing

Method	Simultaneous Rewrite Trigger Timing	TAUBn RDE. TAUBn RDEm	TAUBn RDS. TAUBn RDSm	TAUBn RDM. TAUBn RDMm
—	No simultaneous rewrite	0	0	0
A	The master channel starts/restarts counting.	1	0	0
B	The master channel starts counting down at the upper peak of a triangular cycle.	1	0	1
C1	INTTAUBnIm is generated on an upper channel specified by TAUBnRDC.RDCm	1	1	0

The following table lists which of these three methods is available for each channel operation function. For details on the individual channel operation functions, see Section 13.12, Independent Channel Operation Functions, and Section 13.17, Synchronous Channel Operation Functions.

Table 13-9 Simultaneous Rewrite and Trigger Timing

Function	A	B	C1
Simultaneous rewrite trigger generating function type 1			X
PWM output function	X		X
One-shot pulse output function	X		
Delay pulse output function	X		
Triangle PWM output function		X	X
Triangle PWM output function with dead time		X	X
AD conversion trigger output function type 1	X		X
AD conversion trigger output function type 2		X	X

Note X: available, Space: not available

13.7.2 How to Control Simultaneous Rewrite

The following figure shows the general procedure for simultaneous rewrite. The three main blocks (initial settings, start counter and count operation, and simultaneous rewrite) are explained afterwards.

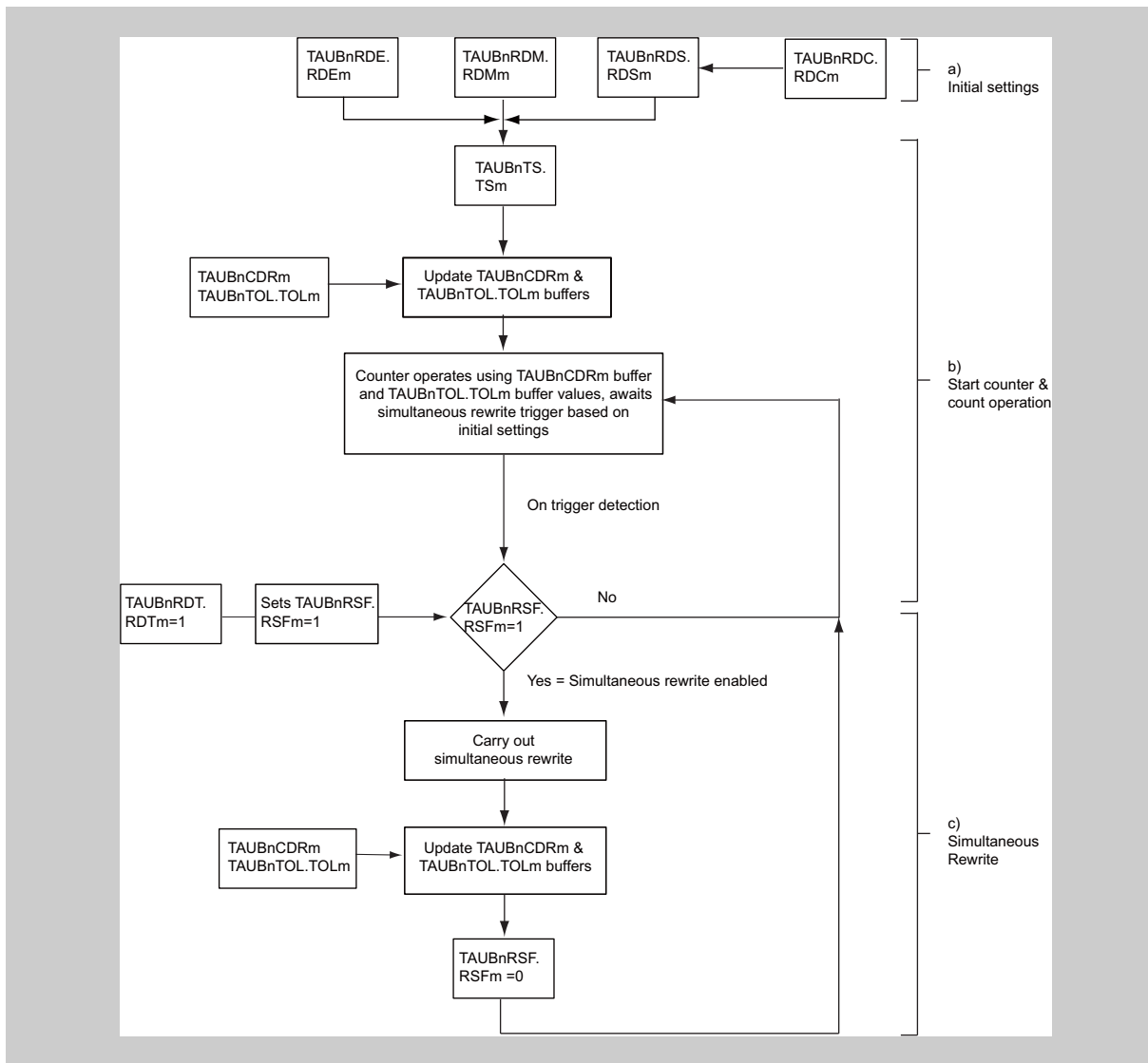

Figure 13-4 General Procedure for Simultaneous Rewrite

(1) Initial settings

- To enable simultaneous rewrite in channel m, set TAUBnRDE.TAUBnRDEm = 1
- To select the type of simultaneous rewrite, set TAUBnRDM.TAUBnRDMm and TAUBnRDS.TAUBnRDSm according to the values listed in Table 13-8, Simultaneous Rewrite Methods and Trigger Timing.
- To select which upper channel is monitored for simultaneous rewrite triggers, use TAUBnRDC.TAUBnRDCm (prerequisite: TAUBnRDS.TAUBnRDSm is set in upper channel.)

(2) Start counter and count operation

- To start all the TAUBnCNTm counters of the channel group, set the corresponding TAUBnTS.TAUBnTSm bits to 1. The values of TAUBnTOL.TAUBnTOLm and the data registers (TAUBnCDRm) are loaded into the corresponding TAUBnTOL.TAUBnTOLm buffer (TAUBnTOL.TAUBnTOLm buf) and data buffer registers (TAUBnCDRm buf) and the counters start.
- Setting the reload data trigger bit (TAUBnRDT.TAUBnRDTm) to 1 sets the reload flag (TAUBnRSF.TAUBnRSFm) to 1, enabling simultaneous rewrite. TAUBnRSF.TAUBnRSFm remains set to 1 until simultaneous rewrite is completed.
- When the specified trigger for simultaneous rewrite is detected, the TAUBnRSF.TAUBnRSFm bit is checked to see if simultaneous rewrite is enabled (TAUBnRSF.TAUBnRSFm = 1). If it is, simultaneous rewrite is carried out. Otherwise the simultaneous rewrite is not carried out and waits for the next trigger detection.

(3) Simultaneous rewrite

- When the simultaneous rewrite trigger is detected and simultaneous rewrite is enabled (TAUBnRSF.TAUBnRSFm = 1), the current values of the data registers are copied to their buffers. These values are then loaded into the corresponding counters and are applied the next time the counter starts or restarts.
- The TAUBnRSF.TAUBnRSFm bit is set to 0, and the system awaits the next simultaneous rewrite trigger.

13.7.3 Other General Rules of Simultaneous Rewrite

The following rules also apply:

- TAUBnRDE.TAUBnRDEm, TAUBnRDS.TAUBnRDSm, TAUBnRDM.TAUBnRDMm, and TAUBnRDC.TAUBnRDCm cannot be changed while the counter is in operation (TAUBnTE.TAUBnTEm = 1).
- TAUBnTOL.TAUBnTOLm can only be rewritten during operation with PWM output function or triangle PWM output function. For all other output functions, TAUBnTOL.TAUBnTOLm should be written before the counter starts. If it is rewritten while any other function is used, TAUBnTTOUTm outputs an invalid wave.
- When an upper channel is used as a channel issuing the simultaneous rewrite trigger (TAUBnRDS.TAUBnRDSm = 1), the TAUBnRDC.TAUBnRDCm bit controls all the lower channels. This means that if the TAUBnRDC.TAUBnRDCm bits of CH2 and CH7 are set to 1 and the TAUBnRDC.TAUBnRDCm bits of other channels are set to 0, CH2 and CH7 serve as simultaneous rewrite trigger generation channels. CH2 controls the lower channels CH3 to CH6, and CH7 controls the lower channels CH8 to CH15.
- If simultaneous rewrite is enabled and an upper channel is selected for the simultaneous rewrite trigger (TAUBnRDE.TAUBnRDEm and TAUBnRDS.TAUBnRDSm = 1) but no upper channel is set (TAUBnRDC.TAUBnRDC[15:0] = 0), simultaneous rewrite cannot take place.

13.7.4 Type of Simultaneous Rewrite

In the following section, the three simultaneous rewrite methods are explained using timing diagrams.

(1) Simultaneous rewrite when the master channel starts/restarts to count (method A)

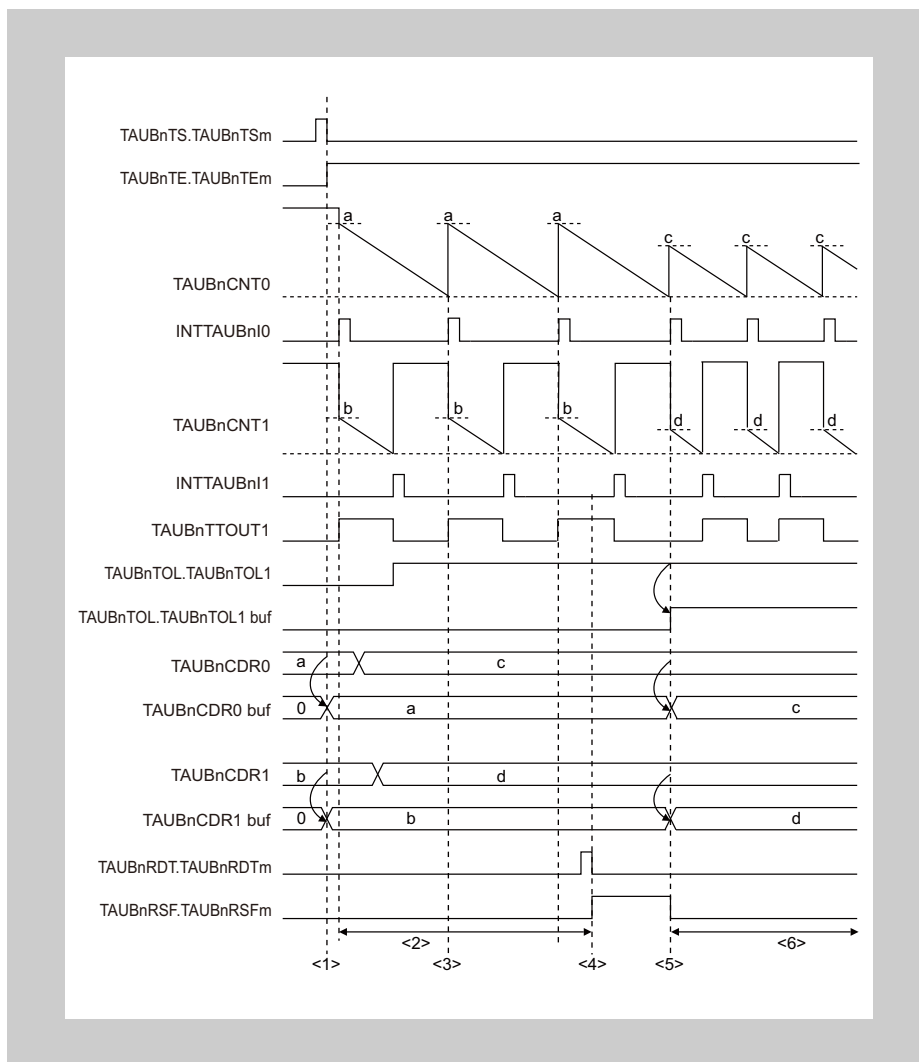

Figure 13-5 Simultaneous Rewrite When the Master Channel Starts/ Restarts Counting

Setting

- CH0 is the master channel which starts counting down, and CH1 represents an arbitrary slave channel. The simultaneous rewrite method A is applied.

Description:

1. When $\text{TAUBnTS.TAUBnTsm} = 1$ is set, the value of TAUBnCDRm is copied to the TAUBnCDRm buffer and the value of $\text{TAUBnTOL.TAUBnTOLm}$ is copied to the $\text{TAUBnTOL.TAUBnTOLm}$ buffer.
2. The TAUBnCDRm and $\text{TAUBnTOL.TAUBnTOLm}$ registers can be written at any time.
3. CH0 restarts counting, but simultaneous rewrite does not occur because it is disabled ($\text{TAUBnRSF.TAUBnRSFm} = 0$)
4. The reload data trigger bit ($\text{TAUBnRDT.TAUBnRDTm}$) is set to 1 which sets the status flag ($\text{TAUBnRSF.TAUBnRSFm} = 1$), enabling simultaneous rewrite.
5. Because simultaneous rewrite is enabled, it is triggered when CH0 restarts counting. The TAUBnCDRm value is loaded into the TAUBnCDRm buffer and the $\text{TAUBnTOL.TAUBnTOLm}$ value is loaded into the $\text{TAUBnTOL.TAUBnTOLm}$ buffer.
6. The counters count down and await the next simultaneous rewrite trigger. The values of TAUBnCDRm and $\text{TAUBnTOL.TAUBnTOLm}$ can be changed again.

(2) Simultaneous rewrite at the peak of a triangular cycle of master channel (method B)

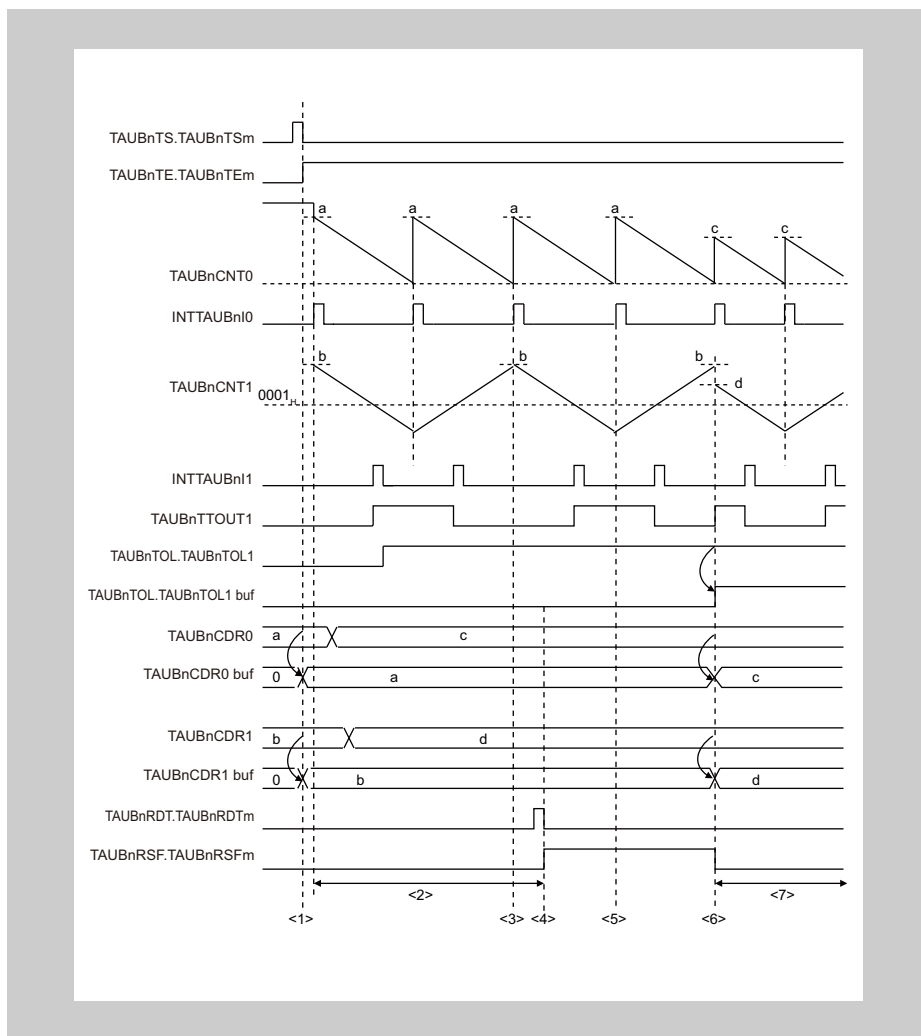

Figure 13-6 Simultaneous Rewrite at the Peak of a Triangular Cycle of Master Channel

Setting

- CH0 is the master channel which performs counting up and down, and CH1 represents an arbitrary slave channel. The simultaneous rewrite method B is applied.

Description:

1. When TAUBTS.TAUBnTSM = 1 is set, the value of TAUBnCDRm is copied to the TAUBnCDRm buffer.
2. The TAUBnCDRm and TAUBnTOL registers can be written at any time.
3. Simultaneous rewrite does not occur because it is disabled (TAUBnRSF.TAUBnRSFm = 0).
4. The reload data trigger bit (TAUBnRDT.TAUBnRDTm) is set to 1 which sets the status flag (TAUBnRSF.TAUBnRSFm = 1), enabling simultaneous rewrite.
5. Simultaneous rewrite does not take place at the bottom of the triangular cycle.
6. Simultaneous rewrite takes place at the top of the triangular cycle. The TAUBnCDRm value is loaded into the TAUBnCDRm buffer, the TAUBnTOL.TAUBnTOLm value is loaded into the TAUBnTOL.TAUBnTOLm buffer.
7. The counters count down and await the next simultaneous rewrite trigger. The values of TAUBnCDRm and TAUBnTOL.TAUBnTOLm can be changed again.

(3) Simultaneous rewrite when INTTAUBn1m is generated on an upper channel specified by TAUBnRDC.TAUBnRDCm (method C1)

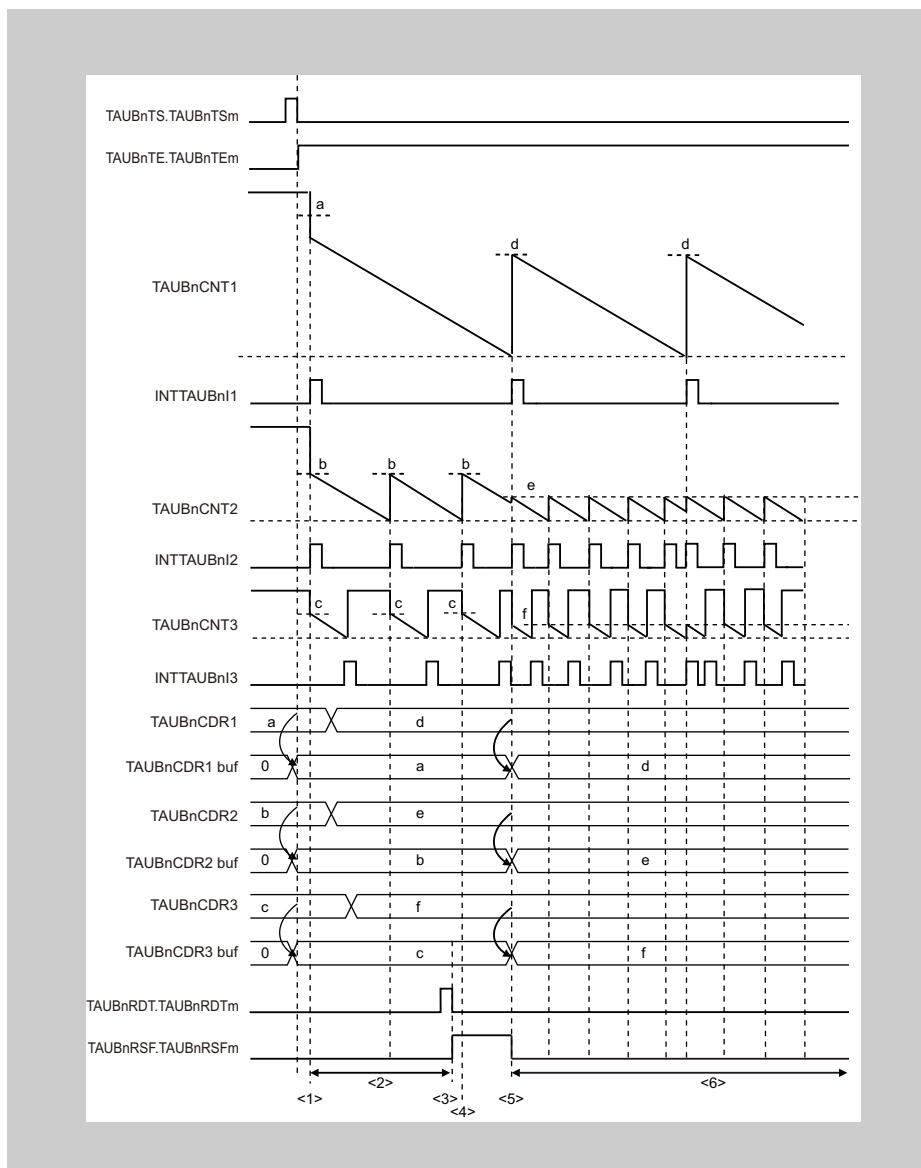

Figure 13-7 Simultaneous Rewrite When INTTAUBn1m Is Generated on an Upper Channel Specified by TAUBnRDC.TAUBnRDCm

Setting

- CH1 is an upper channel used counting down, CH2 is a master channel, and CH3 is the slave channel. The simultaneous rewrite method C1 is applied. The TAUBnRDC register specifies a channel which generates simultaneous rewrite triggers.

Description:

1. When TAUBnTS.TAUBnTSM is set to 1, TAUBnCDRm value is copied to the TAUBnCDRm buffer.
2. The TAUBnCDRm register is always ready to write.
3. By setting the reload data trigger bit (TAUBnRDT.TAUBnRDTm) to 1, the status flag is set (TAUBnRSF.TAUBnRSFm = 1) to enable simultaneous rewrite.
4. Simultaneous rewrite is triggered only by a CH1 interrupt. Therefore, simultaneous rewrite is not conducted even if enabled.
5. Simultaneous rewrite is triggered by INTTAUBn1 which is generated when TAUBnCNT1 reaches 0000_H. The TAUBnCDRm values are loaded into the corresponding TAUBnCDRm buffers.
6. The counter counts down and awaits the next simultaneous rewrite trigger. The values of the TAUBnCDRm registers can be rechanged.

13.8 Channel Output Modes

The output of the TAUBnTTOUTm pin can be controlled in two ways, the latter of which can be further split into individual modes.

- By software (TAUBnTOE.TAUBnTOEm = 0)

When controlled by software, the value written in the output register bit (TAUBnTO.TAUBnTOM) is sent out of the output pin (TAUBnTTOUTm).

- By TAUB signals (TAUBnTOE.TAUBnTOEm = 1)

When controlled by TAUB signals, the output level of TAUBnTTOUTm is set or reset or toggled by internal signals. The value of TAUBnTO.TAUBnTOM is updated accordingly to reflect the value of TAUBnTTOUTm

- Independently (TAUBnTOM.TAUBnTOMm = 0)

In case of independent operation, the output of the TAUBnTTOUTm pin is only affected by settings of channel m. Therefore, independent channel operation should be selected (TAUBnTOM.TAUBnTOMm = 0).

- Synchronously (TAUBnTOM.TAUBnTOMm = 1)

In case of synchronous operation, the output of the TAUBnTTOUTm pin is affected by settings of channel m and those of other channels.

Therefore, synchronous channel operation should be selected for all synchronized channels (TAUBnTOM.TAUBnTOMm = 1).

The TAUBnTO.TAUBnTOM bit can always be read to determine the current value of TAUBnTTOUTm, regardless of whether the pin is controlled by software, operated independently, or operated synchronously.

Control bits The settings of the control bits required to select a specific channel output mode are listed in Table 13-10, Channel Output Modes.

The channel output modes are described in details below.

- Section 13.8.2, Channel Output Modes Controlled Independently by TAUBn Signals
- Section 13.8.3, Channel Output Modes Controlled Synchronously by TAUBn Signals

Batch operation of TAUBnTOM bit Whether a set value is reflected to the TAUBnTOM bit or not is controlled by the TAUBnTOE.TAUBnTOEm bit.

The TAUBnTOM setting is written only to the bit (channel) set with TAUBnTOE.TAUBnTOEm bit = 0 when a write to the TAUBnTO register is attempted. No TAUBnTOM setting is reflected to the bit (channel) set with TAUBnTOE.TAUBnTOEm bit = 1.

Note TAUBnTO.TAUBnTOM bit is placed so that its bit number corresponds to a channel number.

Output logic Positive logic or inverted logic of the output is specified by control bit TAUBnTOL.TAUBnTOLm.

The value of TAUBnTOL.TAUBnTOLm bit should be set before the counter is started. It can only be changed during operation with PWM output function or triangle PWM output function. Otherwise, changes to TAUBnTOL.TAUBnTOLm result in an invalid TAUBnTTOUTm signal output.

See Section 13.7, Simultaneous Rewrite.

The various channel output modes and the channel output control bits are listed in the following table.

Table 13-10 Channel Output Modes

Channel Output Modes	TAUBn TOE. TAUBn TOEm	TAUBn TOM. TAUBn TOMm	TAUBn TOC. TAUBn TOCm	TAUBn TDE. TAUBn TDEm
By software				
Independent channel output mode controlled by software	0	X		
By TAUB signals, independently				
Independent channel output mode 1	1	0	0	0
Independent channel output mode 2			1	
By TAUB signals, synchronously				
Synchronous channel output mode 1	1	1	0	0
Synchronous channel output mode 2			1	
with dead time output				

- Any combinations not described in the above table are prohibited.
- The bit marked with "x" can be set to any value.

Note The following bits cannot be changed during count operation (TAUBnTE.TAUBnTEm = 1):

- TAUBnTOE.TAUBnTOEm
- TAUBnTOM.TAUBnTOMm
- TAUBnTOC.TAUBnTOCm
- TAUBnTDE.TAUBnTDEm

13.8.1 General Procedures for Specifying a Channel Output Mode

This section describes the general procedures for specifying a TAUBnTTOUTm channel output mode. The prerequisite is that timer output operation is disabled (TAUBnTOE.TAUBnTOEm = 0).

1. Set TAUBnTO.TOm to specify the initial level of the TAUBnTTOUTm output.
2. Set channel output mode according to Table 13-10, Channel Output Modes, and the output logic using the TAUBnTOL.TAUBnTOLm bit.
3. Start the counter (TAUBnTS.TAUBnTSm = 1).

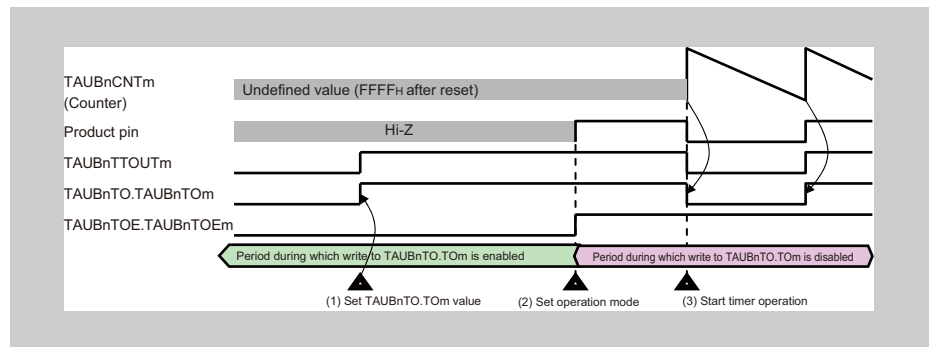

Figure 13-8 General Procedure for Specifying a TAUBnTTOUTm Channel Output Mode

The following figure shows a general illustration of how the output changes when the counter is enabled.

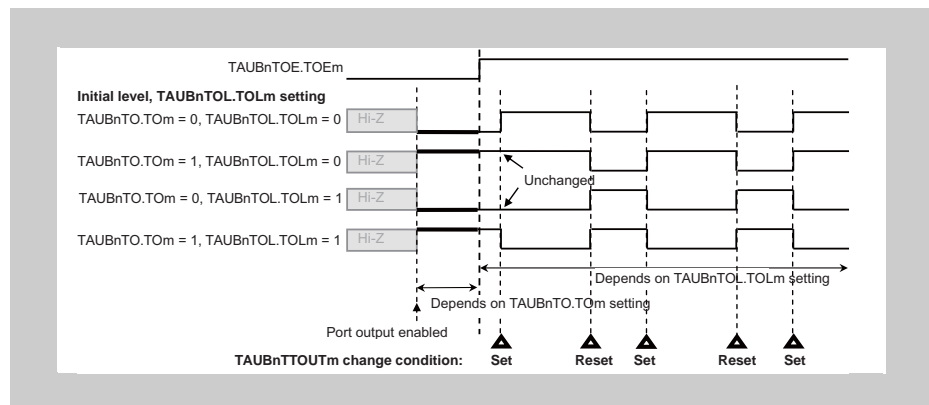

Figure 13-9 General Change of the TAUBnTTOUTm Output

- TAUBnTO.TAUBnTOM sets the initial value of TAUBnTTOUTm and can be changed while TAUBnTOE.TAUBnTOEm=0.
- TAUBnTOL.TAUBnTOLm specifies whether the set signal sets TAUBnTO.TAUBnTOM to high (TAUBnTOL.TAUBnTOLm=0) or low (inverted logic, TAUBnTOL.TAUBnTOLm=1).

13.8.2 Channel Output Modes Controlled Independently by TAUBn Signals

This section lists the channel output modes that are controlled independently by TAUBn signals. The control bits used to specify a mode are listed in Table 13-10, Channel Output Modes.

(1) Independent channel output mode 1

Set/reset conditions In this output mode, TAUBnTTOUTm toggles when INTTAUBnIm is detected. The value of TAUBnTOL.TAUBnTOLm is ignored.

Prerequisites None, other than those in Table 13-10, Channel Output Modes.

(2) Independent channel output mode 2

Set/reset conditions In this output mode, TAUBnTTOUTm is set when INTTAUBnIm occurs upon count start and reset when INTTAUBnIm occurs due to a match between TAUBnCNTm and TAUBnCDRm.

Prerequisites None, other than those in Table 13-10, Channel Output Modes.

13.8.3 Channel Output Modes Controlled Synchronously by TAUBn Signals

This section lists the channel output modes that are controlled synchronously by TAUBn signals. The control bits used to specify a mode are listed in Table 13-10, Channel Output Modes.

(1) Synchronous channel output mode 1

Set/reset conditions In this output mode, INTTAUBnIm of master channel serves as a set signal and INTTAUBnIm of the slave channel as a reset signal. If INTTAUBnIm of master channel and INTTAUBnIm of the slave channel are generated at the same time, INTTAUBnIm of the slave channel (reset signal) has priority over INTTAUBnIm (set signal) of master channel, i.e., the master channel is ignored.

Prerequisites None, other than those in Table 13-10, Channel Output Modes.

(2) Synchronous channel output mode 2

In this output mode, the operating mode should be set to up/down count mode. The result is a triangle PWM wave at TAUBnTTOUTm. For details, see Section 13.20.1, Triangle PWM Output Function.

Set/reset conditions TAUBnCNTm of the slave channel counts down and up alternatively. When it passes 0001_H , it generates an interrupt, causing TAUBnTTOUTm to toggle.

Prerequisites A set of two channels is required to generate the triangle PWM output. TAUBnTTOUTm should be set to 0 before the function starts.

(3) Synchronous channel output mode 2 with dead time output

In this output mode, a dead time delay is added to $TAUBnTTOUTm$. The set/reset conditions are shown in the following figure.

Set/reset conditions

Figure 13-10 Set/Reset Conditions for Synchronous Channel Output Mode 2 with Dead Time Output

With regard to the edge to which dead time is added, set $TAUBnTDL.TAUBnTDLm = 0$ for rising edges and $TAUBnTDL.TAUBnTDLm = 1$ for falling edges.

Prerequisites Dead time control requires a set of three channels, each operating in the following modes:

- One master channel
The master channel should be set to interval timer mode.
- One even slave channel
The even slave channel should be set up/down count mode.
- One odd slave channel (even channel + 1)
The odd slave channel should be set to one-count mode.

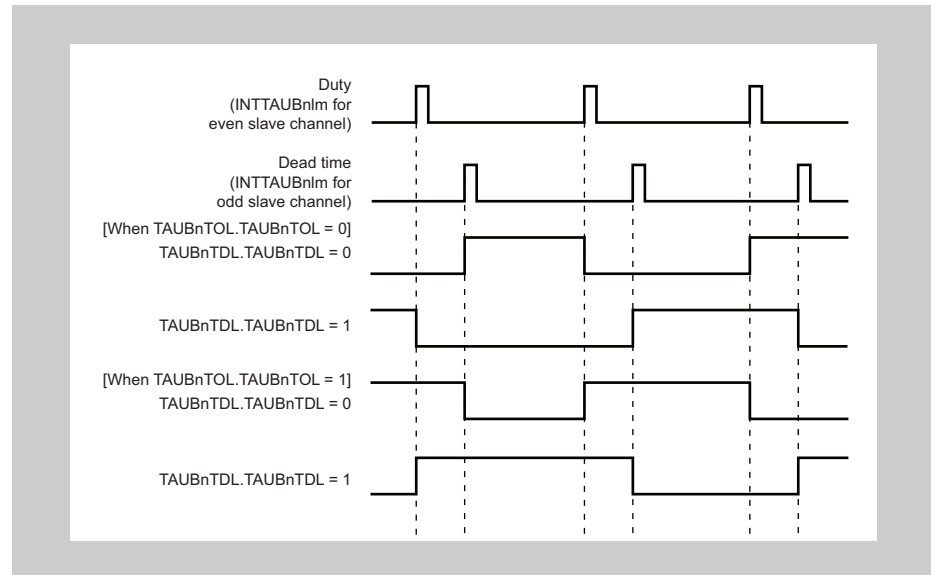
The values of the following bits should be the same for the odd channel and the even channel:

- $TAUBnTOE.TAUBnTOEm$
- $TAUBnTOM.TAUBnTOMm$
- $TAUBnTOC.TAUBnTOCm$
- $TAUBnTDE.TAUBnTDEm$

13.9 Start Timing in Each Operating Modes

This section describes the timing at which the counter starts after TAUBnTS.TAUBnTSM is set to 1 in each operating mode.

In all modes, the value of data register (TAUBnCDRm register) and whether or not an interrupt occurs depends on mode and register settings.

Caution The count start timing described in this section is for your reference. Actually, the count start timing depends on the count clock timing.

13.9.1 Interval Timer Mode, Judge Mode, Capture Mode, and Up/Down Count Mode

The counter starts operating with the next count clock after TAUBnTS.TAUBnTSM is set to 1. The value of data register is also loaded when the counter starts.

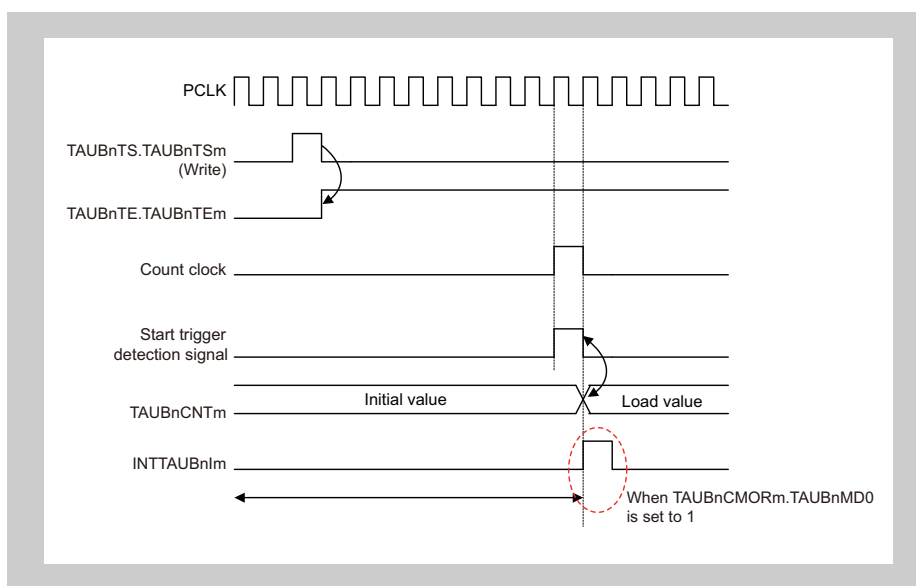

Figure 13-11 Start Timing in Interval Timer Mode, Judge Mode, Capture Mode, and Up/Down Count Mode

Note In up/down count mode, MD0 must be set to 0.

13.9.2 Event Mode

The value of data register (TAUBnCDRm register) is loaded as soon as TAUBnTS.TAUBnTSm is set to 1. The counter also starts immediately. The value of data register (TAUBnCDRm register) increments with subsequent count clocks.

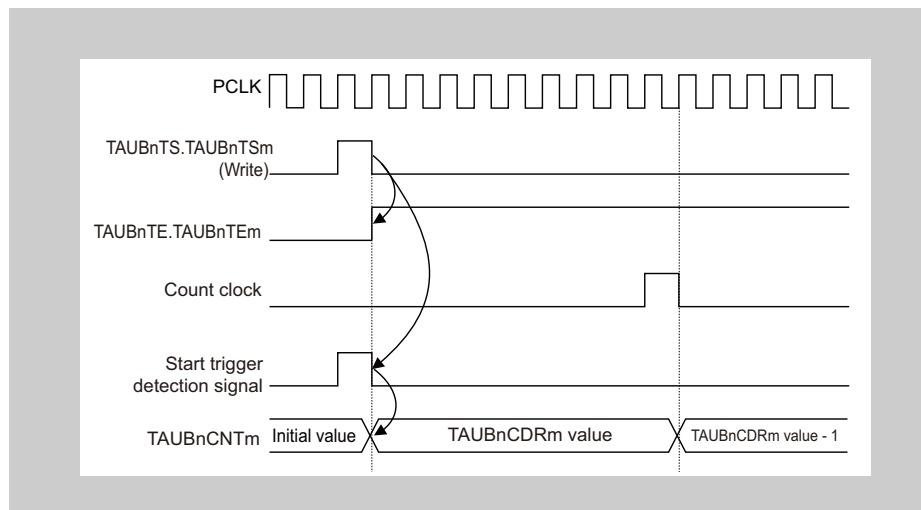

Figure 13-12 Start Timing in Event Mode

13.9.3 Other Operating Modes

In other operating modes, the counter operation start timing is triggered only upon detection of a valid edge of TAUBnTTINm. Once the counter starts, the value of data register (TAUBnCDRm register) is also loaded. The count clock cycles, which is irrelevant to start of counter operation, determine the frequency with which all operations take place.

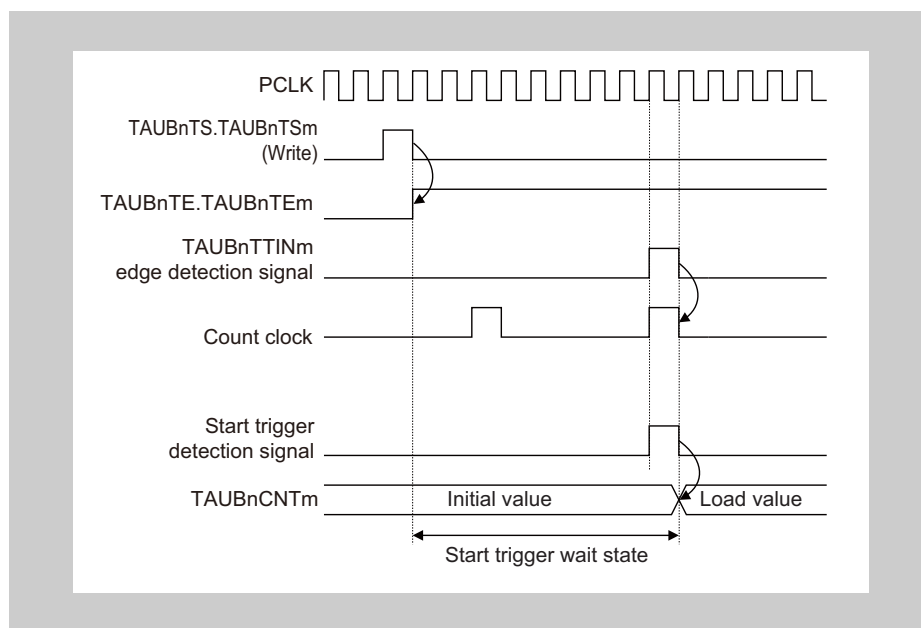

Figure 13-13 Start Timing in Other Operating Modes

13.10 TAUBnTTOUTm Output and INTTAUBnIm Generation when Counter Starts or Restarts (TAUBnMD0 bit)

When the counter starts, it is possible to specify whether an INTTAUBnIm is to be generated using the TAUBnCMORm.TAUBnMD0 bit. The effect of the bit depends on the selected mode, as shown in the following table. The effects of INTTAUBnIm on TAUBnTTOUTm depend on the selected channel operation function.

Table 13-11 Effect of CMOR.TAUBnMD0 Bit on Generation of INTTAUBnIm when Counter Is Triggered

Mode	TAUBnCMOR.MD0 Bit	INTTAUBnIm Generated when Counter Is Started/Restarted or Triggered by TINm Input Signal
Interval timer mode	0	Not generated
Capture mode	1	Generated
Count capture mode		
Capture and one-count mode	0	Not generated
Capture and gate count mode		
Event count mode		
Up/down count mode		
One-count mode	0/1	Not generated, regardless of setting of TAUBnCMORm.TAUBnMD0 bit
Pulse one-count mode		Generated, regardless of setting of TAUBnCMORm.TAUBnMD0 bit

Note As an example see Figure 13-22, Forced Restart Operation (TAUBnCMORm.TAUBnMD0 = 1), TAUBnCMORm.TAUBnMD0 = 1 and Figure 13-22, Forced Restart Operation (TAUBnCMORm.TAUBnMD0 = 1) TAUBnMD0 bit cannot be changed during count operation (TAUBnTE.TAUBnTEm = 1) Refer to Table 13-126, Description of TAUBnCMORm Register for the role of the TAUBnMD0 bit as well.

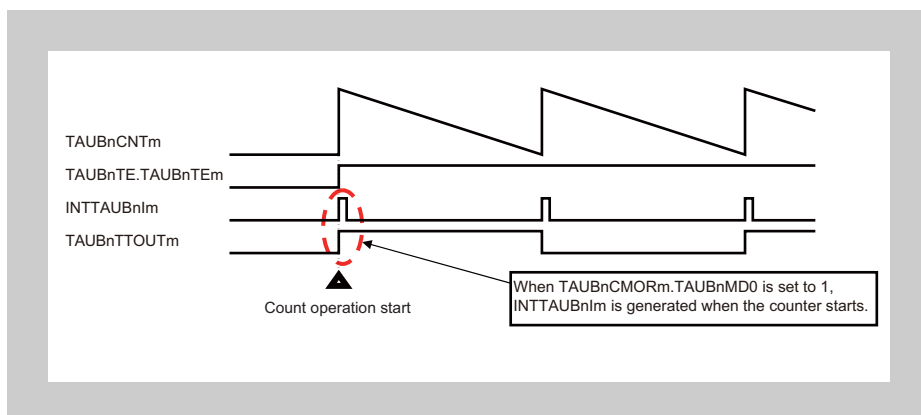

Figure 13-14 INTTAUBnIm Generated When Counter Starts

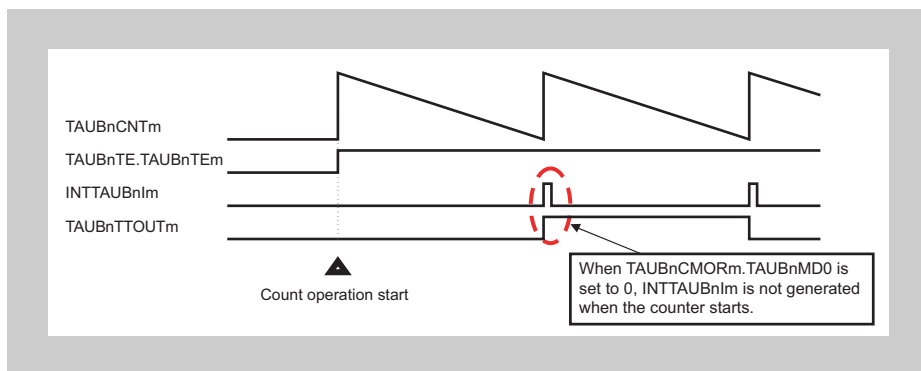

Figure 13-15 INTTAUBnIm Not Generated When Counter Starts

13.11 TAUBnTTINm Edge Detection

Edge detection is based on the operation clock. This means that an edge can only be detected at the next rising edge of the operation clock. This can lead to a maximum delay of one operation clock cycle.

The following figure shows when edge detection takes place.

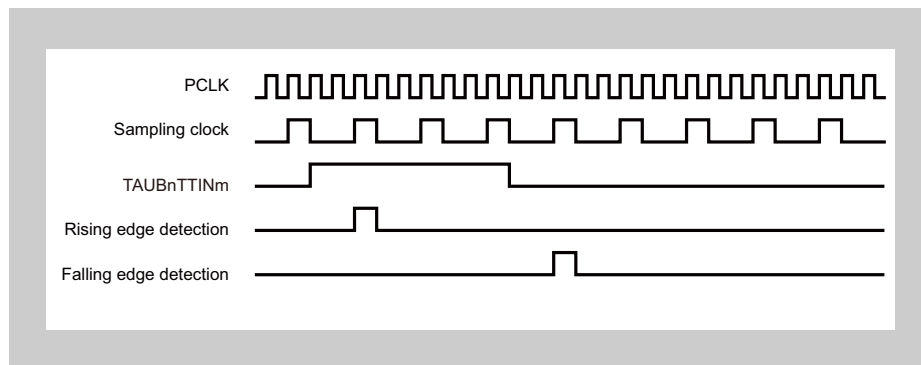

Figure 13-16 Basic Edge Detection Timing

Caution Figure 13-6, Basic Edge Detection Timing, shows an operation timing image. Actually, a noise filter or synchronization circuit which is located between the TAUBnIm pin and TAUBn causes a delay time.

- When using a noise filter
Noise filter delay time + edge detection delay time (maximum one sampling clock)
- When not using a noise filter
Synchronization circuit delay time (maximum two PCLK) + edge detection delay time (maximum one sampling clock)

13.12 Independent Channel Operation Functions

The following sections list the independent channel operation functions provided by the TAUB. For a general overview of independent channel operation, see Section 13.3, Functional Description.

13.13 Independent Channel Interrupt Functions

This section describes functions that generate interrupts at regular intervals or with a specified delay.

- Section 13.13.1, Interval Timer Function
- Section 13.13.2, TAUBnTTINm Input Interval Timer Function
- Section 13.13.3, One-Pulse Output Function

13.13.1 Interval Timer Function

(1) Overview

- Summary** This function is used as a reference timer for generating timer interrupts (INTTAUBnIm) at regular intervals. When an interrupt is generated, the TAUBnTTOUTm signal toggles, resulting in a square wave.
- Prerequisites**
- The operating mode should be set to Interval timer mode. (See Table 13-12, TAUBnCMORm Settings for Interval Timer Function.)
 - The channel output mode should be set to independent channel output mode 1. (See Section 13.8, Channel Output Modes.)
- Description** The counter is started by setting the channel trigger bit (TAUBnTS.TAUBnTSM) to 1. This in turn sets TAUBnTE.TAUBnTEM = 1, enabling count operation. The current value of TAUBnCDRm is loaded into TAUBnCNTm and the counter starts to count down from this value.
- When the counter reaches 0000_H, INTTAUBnIm is generated and the TAUBnTTOUTm signal toggles. The TAUBnCDRm value is loaded in TAUBnCNTm and subsequently operation continues.
- The value of TAUBnCDRm can be rewritten at any time, and the changed value of TAUBnCDRm is applied the next time the counter starts to count down.
- The counter can be stopped by setting TAUBnTT.TAUBnTTM to 1. This sets TAUBnTE.TAUBnTEM to 0. TAUBnCNTm and TAUBnTTOUTm stop but retain their values. The counter can be restarted by setting TAUBnTS.TAUBnTSM to 1. The counter can also be forcibly restarted (without stopping it first) by setting TAUBnTS.TAUBnTSM to 1 during operation.
- Conditions** If the TAUBnCMORm.TAUBnMD0 bit is set to 0, the first interrupt after a start or restart is not generated, and therefore TAUBnTTOUTm does not toggle. This results in an inverted TAUBnTTOUTm signal compared to when TAUBnCMORm.TAUBnMD0 is set to 1. For details, see Section 13.10, TAUBnTTOUTm Output and INTTAUBnIm Generation when Counter Starts or Restarts (TAUBnMD0 bit).

(2) Equations

$$\text{INTTAUBnIm cycle} = \text{count clock cycle} \times (\text{TAUBnCDRm} + 1)$$

$$\text{TAUBnTTOUTm square wave cycle} = \text{count clock cycle} \times (\text{TAUBnCDRm} + 1) \times 2$$

(3) Block diagram and general timing diagram

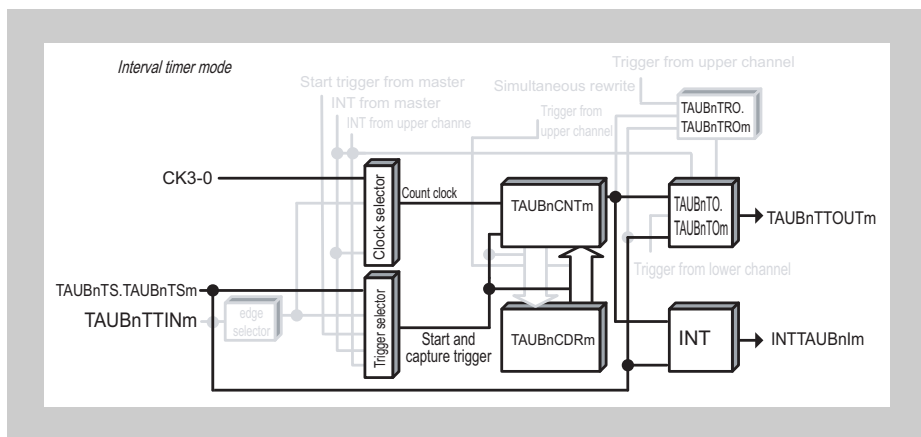

Figure 13-17 Block Diagram of Interval Timer Function

The following settings apply to the general timing diagram.

- INTTAUBnIm is generated at the beginning of operation (TAUBnCMORm.TAUBnMD0 = 1)

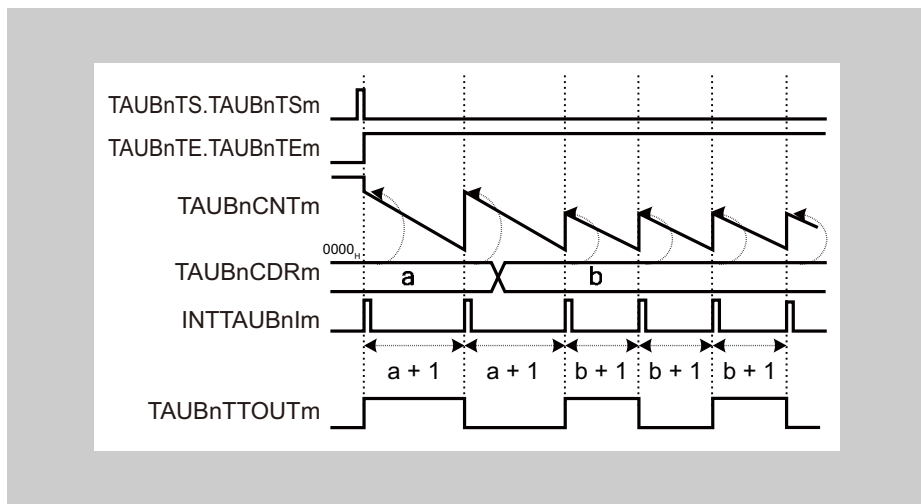

Figure 13-18 General Timing Diagram of Interval Timer Function

(4) Register settings

(a) TAUBnCMORm

15	14	13	12	11	10	9	8	7	6	5	4	3	2	1	0
TAUBnCKS [1:0]	TAUBnCCS [1:0]	TAUBnMAS	TAUBnSTS[2:0]			TAUBnCOS [1:0]	-	TAUBnMD[4:1]				TAUBnMDO			

Table 13-12 TAUBnCMORm Settings for Interval Timer Function

Bit Name	Setting
TAUBnCKS[1:0]	00: Operation clock = CK0 01: Operation clock = CK1 10: Operation clock = CK2 11: Operation clock = CK3
TAUBnCCS[1:0]	00: Uses an operation clock as a count clock.
TAUBnMAS	0: Unused. Set to 0.
TAUBnSTS[2:0]	000: Triggers the counter by software.
TAUBnCOS[1:0]	00: Unused. Set to 00.
TAUBnMD[4:1]	0000: Interval timer mode
TAUBnMDO	0: INTTAUBnIm is not generated to toggle TAUBnTTOUm at the beginning of an operation. 1: INTTAUBnIm is generated to toggle TAUBnTTOUm at the beginning of an operation.

(b) TAUBnCMURm

7	6	5	4	3	2	1	0
-						TAUBnTIS[1:0]	

Table 13-13 TAUBnCMURm Settings for Interval Timer Function

Bit Name	Setting
TAUBnTIS[1:0]	00: Unused. Set to 00.

(c) Channel output mode**Table 13-14 Control Bit Settings in Independent Channel Output Mode 1**

Bit Name	Setting
TAUBnTOE.TAUBnTOEm	1: Enables independent channel output mode.
TAUBnTOM.TAUBnTOMm	0: Independent channel output
TAUBnTOC.TAUBnTOCm	0: Operating mode 1 (Toggle mode if TAUBnTOM.TAUBnTOMm = 0)
TAUBnTOL.TAUBnTOLm	0: Positive logic
TAUBnTDE.TAUBnTDEm	0: Disables dead time operation.
TAUBnTDL.TAUBnTDLm	0: Disables dead time operation.

Note The channel output mode can also be set to Channel Output Mode Controlled by Software by setting TAUBnTOE.TAUBnTOEm = 0. TAUBnTOUTm can then be controlled independently of the interrupts. For details, see Section 13.8, Channel Output Modes.

(d) Simultaneous rewrite

The simultaneous rewrite registers (TAUBnRDE, TAUBnRDS, TAUBnRDM, and TAUBnRDC) cannot be used with the interval timer function. Therefore, these registers should be set to 0.

Table 13-15 Simultaneous Rewrite Settings for Interval Timer Function

Bit Name	Setting
TAUBnRDE.TAUBnRDEm	0: Disables simultaneous rewrite.
TAUBnRDS.TAUBnRDSm	0: When simultaneous rewrite is disabled (TAUBnRDE.TAUBnRDEm = 0), set these bits to 0.
TAUBnRDM.TAUBnRDMm	
TAUBnRDC.TAUBnRDCm	

(5) Operating procedure for interval timer function

Table 13-16 Operating Procedure for Interval Timer Function

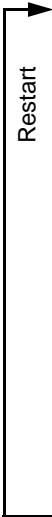
	Operation	TAUBn Status	
 Restart	Initial Channel Setting	Set TAUBnCMORm and TAUBnCMURm registers as described in Table 13-12, TAUBnCMORm Settings for Interval Timer Function, and Table 13-13, TAUBnCMURm Settings for Interval Timer Function. Set the value of TAUBnCDRm register. Set channel output mode by setting the control bits as described in Table 13-14, Control Bit Settings in Independent Channel Output Mode 1.	Channel operation is stopped.
	Start Operation	Set TAUBnTS.TAUBnTSM to 1. TAUBnTS.TAUBnTSM is a trigger bit, which is automatically cleared to 0.	TAUBnTE.TAUBnTEM is set to 1 and the counter starts. The TAUBnCDRm value is loaded in TAUBnCNTm. When TAUBnCMORm.MD0 = 1, INTTAUBnIm is generated and TAUBnTTOUTm toggles.
	During Operation	The TAUBnCDRm register value can be changed at any time. The TAUBnCNTm register can be read at all times.	TAUBnCNTm counts down. When the counter reaches 0000 _H . <ul style="list-style-type: none"> • The TAUBnCDRm value is loaded in TAUBnCNTm again and count operation continues. • INTTAUBnIm is generated and TAUBnTTOUTm toggles.
	Stop Operation	Set TAUBnTT.TAUBnTTM to 1. TAUBnTT.TAUBnTTM is a trigger bit, which is automatically cleared to 0.	TAUBnTE.TAUBnTEM is cleared to 0 and the counter stops. TAUBnCNTm and TAUBnTTOUTm stop and retain their current values.

(6) Specific timing diagrams

(a) TAUBnCDRm = 0000_H, count clock = PCLK/2

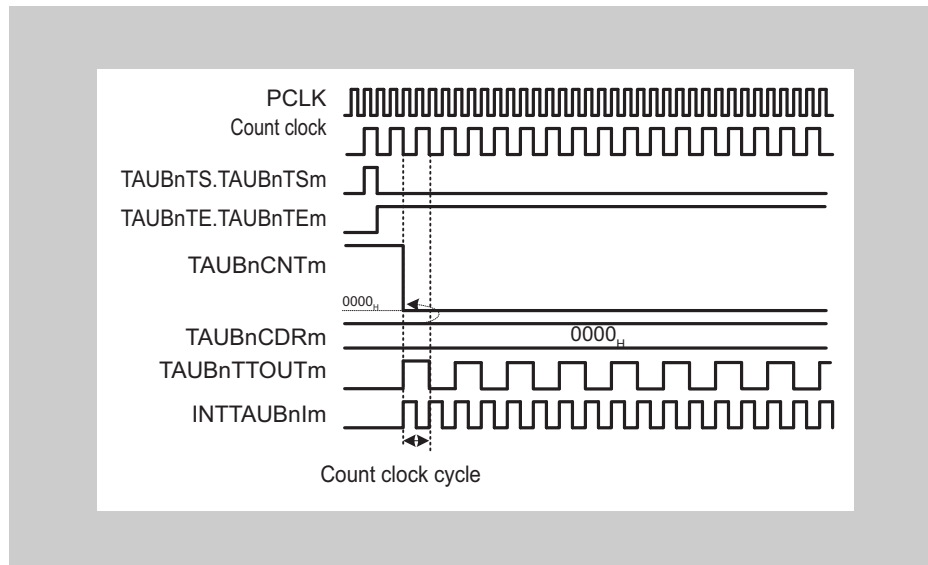

Figure 13-19 TAUBnCDRm = 0000_H, Count Clock = PCLK/2

- If TAUBnCDRm = 0000_H and the count clock = PCLK/2¹, the TAUBnCDRm value is loaded into TAUBnCNTm every count clock, meaning that TAUBnCNTm is always 0000_H.
- INTTAUBnIm is generated every count clock, resulting in TAUBnTTOUTm toggling every count clock.

(b) TAUBnCDRm = 0000_H, count clock = PCLK

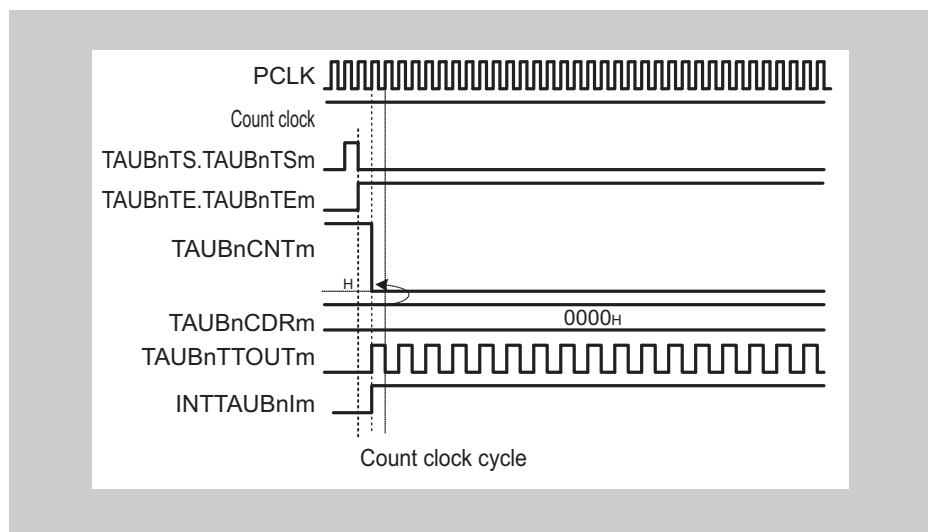

Figure 13-20 TAUBnCDRm = 0000_H, Count Clock = PCLK

- If TAUBnCDRm = 0000_H and the count clock = PCLK, the TAUBnCDRm value is loaded into TAUBnCNTm every PCLK clock, meaning that TAUBnCNTm is always 0000_H.
- INTTAUBnIm is generated continuously, resulting in TAUBnTTOUTm toggling every PCLK clock.

(c) Operation stop and restart

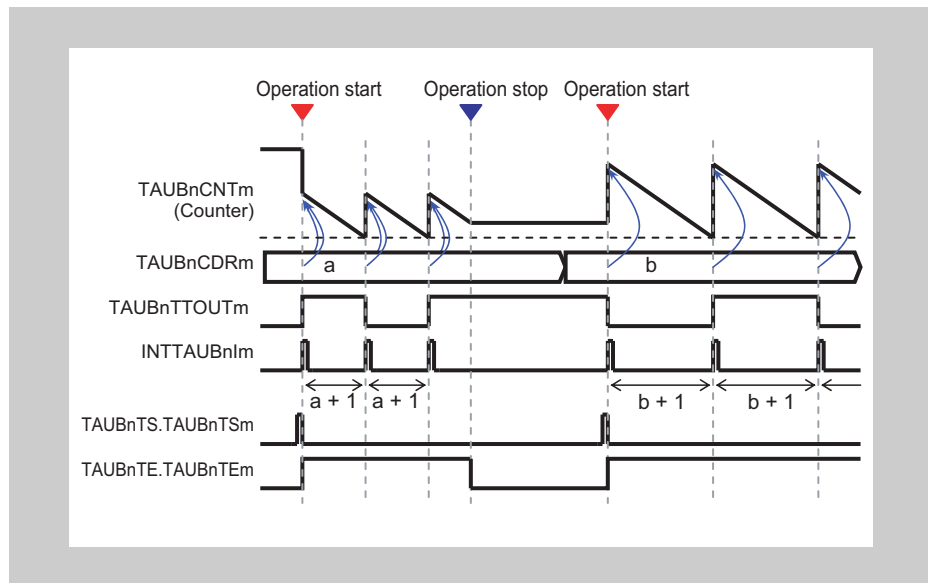

Figure 13-21 Operation Stop and Restart (TAUBnCMORm.TAUBnMD0 = 1)

- The counter can be stopped by setting TAUBnTT.TAUBnTTm to 1. This sets TAUBnTE.TAUBnTEm to 0.
- TAUBnCNTm and TAUBnTTOUtm stop but retain their values.
- The counter can be restarted by setting TAUBnTS.TAUBnTsm to 1.

(d) Forced restart

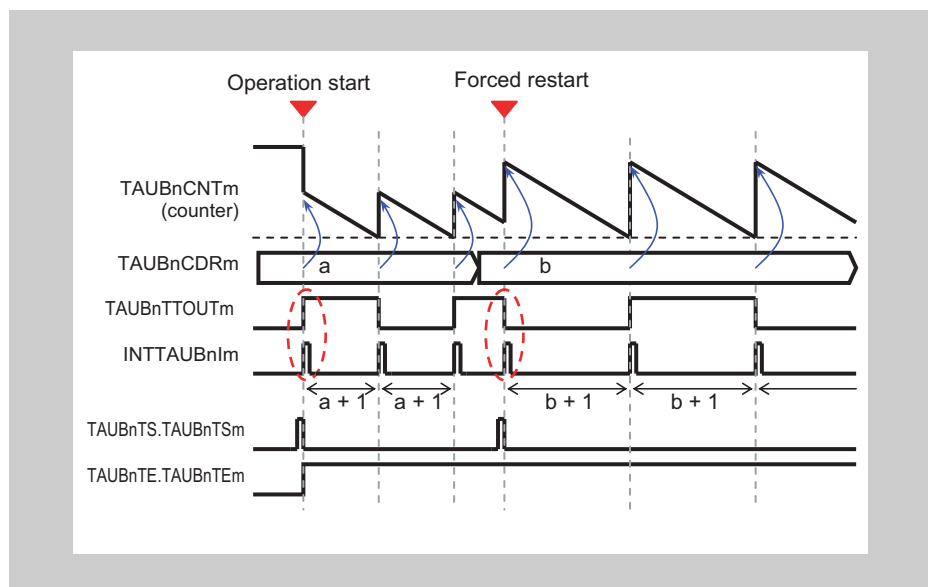

Figure 13-22 Forced Restart Operation (TAUBnCMORm.TAUBnMD0 = 1)

- The counter can be forcibly restarted (without stopping it first) by setting TAUBnTS.TAUBnTsm to 1 during operation.
- If the TAUBnCMORm.TAUBnMD0 bit is set to 1, the first interrupt after a start or restart is generated.

13.13.2 TAUBnTTINm Input Interval Timer Function

(1) Overview

- Summary** This function is used as a reference timer for generating timer interrupts (INTTAUBnIm) at regular intervals or when a valid TAUBnTTINm input edge is detected. When an interrupt is generated, the TAUBnTTOUTm signal toggles, resulting in a square wave.
- Prerequisites**
- The operating mode should be set to interval timer mode. See Table 13-17, TAUBnCMORm Settings for TAUBnTTINm Input Interval Timer Function.
 - The channel output mode should be set to independent channel output mode 1. See Section 13.8, Channel Output Modes.
- Description** This function operates in an identical manner to the interval timer function (see Section 13.13.1, Interval Timer Function) except that this function is restarted by a valid TAUBnTTINm input edge. The type of edge used as a trigger is specified using the TAUBnCMURm.TAUBnTIS[1:0] bits. Either rising edge, falling edge, or rising and falling edge can be selected.

(2) Equations

$$\text{INTTAUBnIm cycle} = \text{count clock cycle} \times (\text{TAUBnCDRm} + 1)$$

$$\text{TAUBnTTOUTm square wave cycle} = \text{count clock cycle} \times (\text{TAUBnCDRm} + 1) \times 2$$

(3) Block diagram and general timing diagram

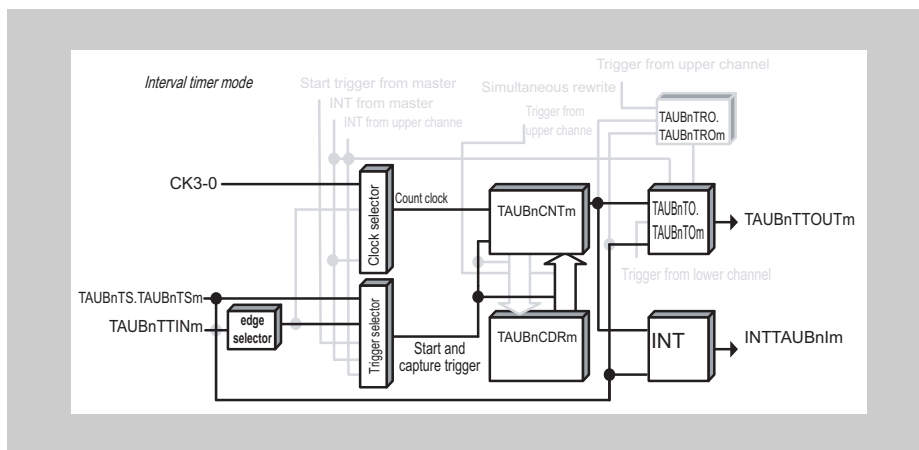

Figure 13-23 Block Diagram of TAUBnTTINm Input Interval Timer Function

The following settings apply to the general timing diagram.

- INTTAUBnIm is generated at the beginning of operation (TAUBnCMORm.TAUBnMD0 = 1)
- Rising edge detection (TAUBnCMURm.TAUBnTIS[1:0] = 01_B)

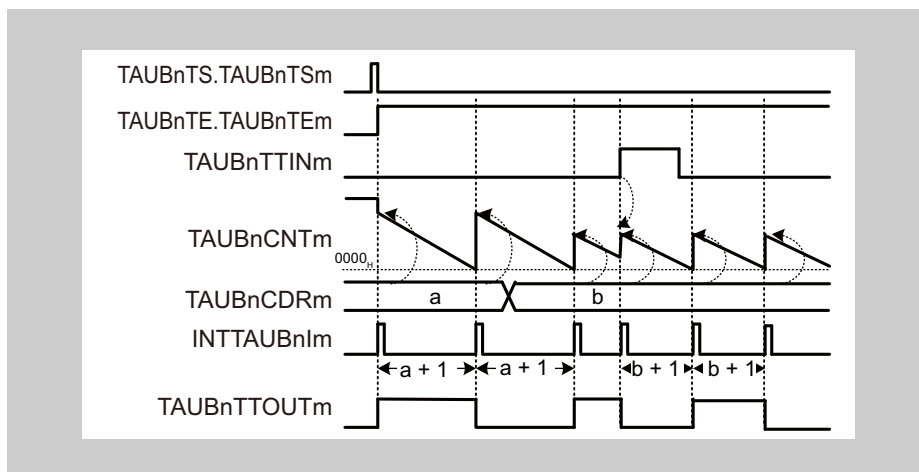

Figure 13-24 General Timing Diagram of TAUBnTTINm Input Interval Timer Function

(4) Register settings**(a) TAUBnCMORM**

15	14	13	12	11	10	9	8	7	6	5	4	3	2	1	0
TAUBnCKS [1:0]	TAUBnCCS [1:0]	TAUB nMAS	TAUBnSTS[2:0]		TAUBnCOS [1:0]	-		TAUBnMD[4:1]				TAUB nMDO			

Table 13-17 TAUBnCMORM Settings for TAUBnTTINm Input Interval Timer Function

Bit Name	Setting
TAUBnCKS[1:0]	00: Operation clock = CK0 01: Operation clock = CK1 10: Operation clock = CK2 11: Operation clock = CK3
TAUBnCCS[1:0]	00: Uses an operation clock as a count clock.
TAUBnMAS	0: Unused. Set to 0.
TAUBnSTS[2:0]	001: Valid TAUBnTTINm input edge signal is used as an external start trigger.
TAUBnCOS[1:0]	00: Unused. Set to 00.
TAUBnMD[4:1]	0000: Interval timer mode
TAUBnMDO	0: INTTAUBnIm is not generated to toggle TAUBnTTOUm at the beginning of an operation. 1: INTTAUBnIm is generated to toggle TAUBnTTOUm at the beginning of an operation.

(b) TAUBnCMURm

7	6	5	4	3	2	1	0
-							TAUBnTIS[1:0]

Table 13-18 TAUBnCMURm Settings for TAUBnTTINm Input Interval Timer Function

Bit Name	Setting
TAUBnTIS[1:0]	00: Falling edge detection 01: Rising edge detection 10: Rising and falling edge detection

(c) Channel output mode**Table 13-19 Control Bit Settings in Independent Channel Output Mode 1**

Bit Name	Setting
TAUBnTOE.TAUBnTOEm	1: Enables independent channel output mode.
TAUBnTOM.TAUBnTOMm	0: Independent channel output
TAUBnTOC.TAUBnTOCm	0: Operating mode = 1 (Toggle mode if TAUBnTOM.TAUBnTOMm = 0)
TAUBnTOL.TAUBnTOLm	0: Positive logic
TAUBnTDE.TAUBnTDEm	0: Disables dead time operation.
TAUBnTDL.TAUBnTDLm	0: When disabling dead time operation (TAUBnTDE.TAUBnTDEm = 0), set these bits to 0.

Note The channel output mode can also be set to channel output mode controlled by software by setting TAUBnTOE.TAUBnTOEm = 0. TAUBnTOUTm can then be controlled independently of the interrupts. For details, see Section 13.8, Channel Output Modes.

(d) Simultaneous rewrite

The simultaneous rewrite registers (TAUBnRDE, TAUBnRDS, TAUBnRDM, and TAUBnRDC) cannot be used with the TAUBnTTINm Input Interval Timer Function. Therefore, these registers should be set to 0.

Table 13-20 Simultaneous Rewrite Settings for TAUBnTTINm Input Interval Timer Function

Bit Name	Setting
TAUBnRDE.TAUBnRDEm	0: Disables simultaneous rewrite.
TAUBnRDS.TAUBnRDSm	0: When disabling simultaneous rewrite (TAUBnRDE.TAUBnRDEm = 0), set these bits to 0.
TAUBnRDM.TAUBnRDMm	
TAUBnRDC.TAUBnRDCm	

(5) Operating procedure for TAUBnTTINm input interval timer function

Table 13-21 Operating Procedure for TAUBnTTINm Input Interval Timer Function

	Operation	TAUBn Status
Restart ↓	Initial Channel Setting Set TAUBnCMORm and TAUBnCMURm registers as described in Table 13-17, TAUBnCMORm Settings for TAUBnTTINm Input Interval Timer Function, and Table 13-18, TAUBnCMURm Settings for TAUBnTTINm Input Interval Timer Function. Set the value of TAUBnCDRm register. Set channel output mode by setting the control bits as described in Table 13-19, Control Bit Settings in Independent Channel Output Mode 1.	Channel operation is stopped.
	Start Operation Set TAUBnTS.TAUBnTSm to 1. TAUBnTS.TAUBnTSm is a trigger bit, which is automatically cleared to 0.	TAUBnTE.TAUBnTEm is set to 1 and the counter starts. The TAUBnCDRm value is loaded in TAUBnCNTm. When TAUBnCMORm.TAUBnMD0 = 1, INTTAUBnIm is generated and TAUBnTTOUTm toggles.
	During Operation The values of the TAUBnCMURm.TAUBnTIS[1:0] bits and the TAUBnCDRm register are changeable at any time. The TAUBnCNTm register are readable at any time. Detection of TAUBnTTINm edge	TAUBnCNTm counts down. When the counter reaches 0000 _H . <ul style="list-style-type: none"> The TAUBnCDRm value is loaded in TAUBnCNTm again and count operation continues. INTTAUBnIm is generated and TAUBnTTOUTm toggles. When a TAUBnTTINm input valid edge is detected during count operation, the TAUBnCDRm value is loaded in TAUBnCNTm and count operation continues. Afterwards, this procedure is repeated.
	Stop Operation Set TAUBnTT.TAUBnTTm to 1. TAUBnTT.TAUBnTTm is a trigger bit, which is automatically cleared to 0.	TAUBnTE.TAUBnTEm is cleared to 0 and the counter stops TAUBnCNTm and TAUBnTTOUTm stop and retain their current values.

(6) Specific timing diagram

The timing diagrams in Section 13.13.1, Interval Timer Function. The counter can also be restarted by a valid TAUBnTTINm input edge without using this function.

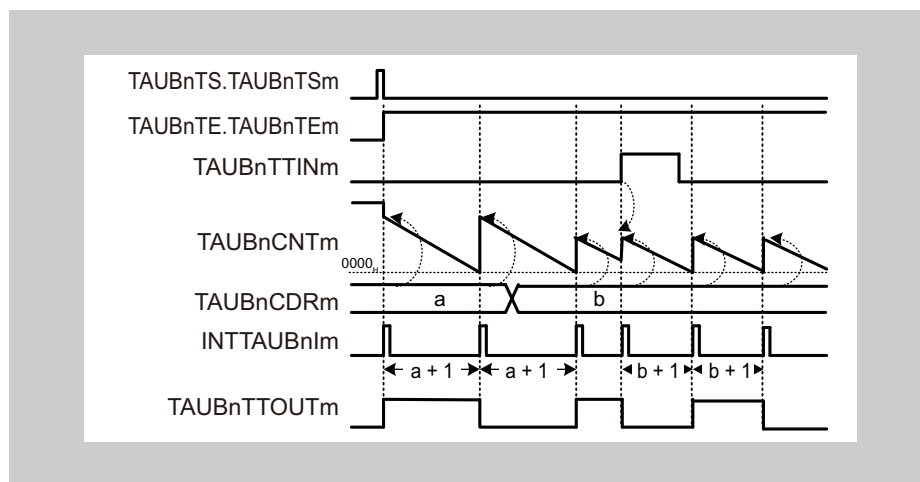

Figure 13-25 Counter Triggered by Rising TAUBnTTINm Input Edge (TAUBnCMURm.TAUBnTIS[1:0] = 01_B), TAUBnCMORm.TAUBnMD0 = 1

- If a valid TAUBnTTINm input edge is detected, an interrupt is generated which causes TAUBnTTOUTm to toggle. In this example, the valid edge is a rising edge (TAUBnCMURm.TAUBnTIS[1:0] = 01_B).

13.13.3 One-Pulse Output Function

(1) Overview

- Summary** This function generates an interrupt (INTTAUBnIm) when a valid TAUBnTTINm input edge is detected and at a defined interval afterward. TAUBnTTINm input signal pulses that occur within the defined interval are ignored. When an interrupt is generated, the TAUBnTTOUTm signal toggles, resulting in a square wave.
- Prerequisites**
- The operating mode should be set to pulse one-count mode. (See Table 13-22, TAUBnCMORm Settings for One-Pulse Output Function.)
 - The channel output mode should be set to independent channel output mode 2. (See Section 13.8, Channel Output Modes.)
 - Trigger detection should be disabled during counting (TAUBnCMORn.TAUBnMD0 = 0).
- Description** The counter is enabled by setting the channel trigger bit (TAUBnTS.TAUBnTSM) to 1. This in turn sets TAUBnTE.TAUBnTEm = 1, enabling count operation.
- The counter starts when a valid TAUBnTTINm input edge is detected. The value of TAUBnCDRm is loaded into TAUBnCNTm and the counter starts to count down from the TAUBnCDRm value. An interrupt is generated and TAUBnTTOUTm toggles.
- When the counter reaches 0001_H, an interrupt is generated and TAUBnTTOUTm is set to the inactive level. The counter stops at 0000_H and awaits the next valid TAUBnTTINm input edge.
- When the counter is counting down, further TAUBnTTINm input signals are ignored, i.e., the counter does not reset.
- The value of TAUBnCDRm can be rewritten at any time, and the changed value of TAUBnCDRm is applied the next time the counter starts to count down.
- Conditions** The type of edge used as a trigger is specified by the TAUBnCMURm.TAUBnTIS[1:0] bits:
- If TAUBnCMURm.TAUBnTIS[1:0] = 00_B, falling edges trigger the counter.
 - If TAUBnCMURm.TAUBnTIS[1:0] = 01_B, rising edges trigger the counter.
 - If TAUBnCMURm.TAUBnTIS[1:0] = 10_B, rising and falling edges trigger the counter.
- (2) Equations**
- Interval between TAUBnTTINm and INTTAUBnIm = TAUBnTTOUTm (timer output) width = count clock cycle × TAUBnCDRm

(3) Block diagram and general timing diagram

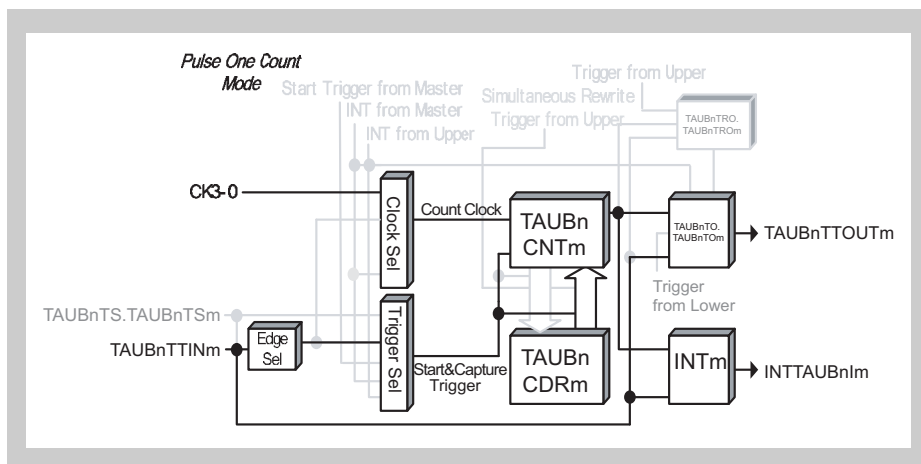

Figure 13-26 Block Diagram of One-Pulse Output Function

The following settings apply to the general timing diagram.

- Detection of falling edge (TAUBnCMURm.TAUBnTIS[1:0] = 00_B)

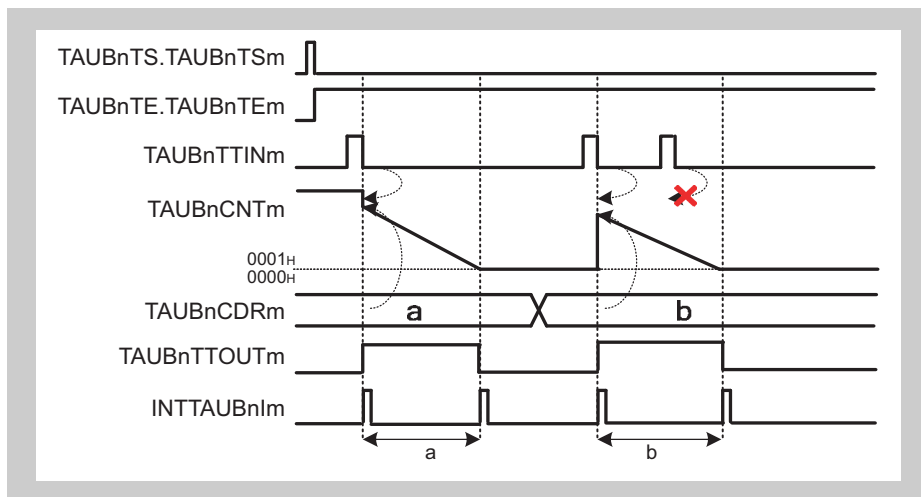

Figure 13-27 General Timing Diagram of One-Pulse Output Function

(4) Register settings

(a) TAUBnCMORm

15	14	13	12	11	10	9	8	7	6	5	4	3	2	1	0
TAUBnCKS [1:0]	TAUBnCCS [1:0]	TAUB nMAS	TAUBnSTS[2:0]			TAUBnCOS [1:0]	-	TAUBnMD[4:1]				TAUB nMDO			

Table 13-22 TAUBnCMORm Settings for One-Pulse Output Function

Bit Name	Setting
TAUBnCKS[1:0]	00: Operation clock = CK0 01: Operation clock = CK1 10: Operation clock = CK2 11: Operation clock = CK3
TAUBnCCS[1:0]	00: Uses an operation clock as the count clock.
TAUBnMAS	0: Unused. Set to 0.
TAUBnSTS[2:0]	001: Valid TAUBnTTINm input edge signal is used as an external start trigger.
TAUBnCOS[1:0]	00: Unused. Set to 00.
TAUBnMD[4:1]	1010: Pulse one-count mode
TAUBnMDO	0: Disables a start trigger during operation.

(b) TAUBnCMURm

7	6	5	4	3	2	1	0
-						TAUBnTIS[1:0]	

Table 13-23 TAUBnCMURm Settings for One-Pulse Output Function

Bit Name	Setting
TAUBnTIS[1:0]	00: Falling edge detection 01: Rising edge detection 10: Rising and falling edge detection (low width measurement) 11: Setting prohibited

(c) Channel output mode**Table 13-24 Control Bit Settings in Independent Channel Output Mode 1**

Bit Name	Setting
TAUBnTOE.TAUBnTOEm	1: Enables independent channel output mode controlled by software.
TAUBnTOM.TAUBnTOMm	0: Independent channel output
TAUBnTOC.TAUBnTOCm	1: Independent channel output mode
TAUBnTOL.TAUBnTOLm	0: Positive logic 1: Inverted logic
TAUBnTDE.TAUBnTDEm	0: Disables dead time operation.
TAUBnTDL.TAUBnTDLm	0: When dead time operation is disabled (TAUBnTDE.TDEm=0), set these bits to 0

Note The channel output mode can also be set to channel output mode controlled by software by setting TAUBnTOE.TAUBnTOEm = 0. TAUBnTTOUTm can then be controlled independently of the interrupts. For details, see Table 13-10, Channel Output Modes.

(d) Simultaneous rewrite

The simultaneous rewrite registers (TAUBnRDE, TAUBnRDS, TAUBnRDM, and TAUBnRDC) cannot be used with the One-Pulse Output Function. Therefore, these registers should be set to 0.

Table 13-25 Simultaneous Rewrite Settings for One-Pulse Output Function

Bit Name	Setting
TAUBnRDE.TAUBnRDEm	0: Disables simultaneous rewrite.
TAUBnRDS.TAUBnRDSm	0: When disabling simultaneous rewrite (TAUBnRDE.TAUBnRDEm = 0), set these bits to 0.
TAUBnRDM.TAUBnRDMm	
TAUBnRDC.TAUBnRDCm	

(5) Operating procedure for one-pulse output function

Table 13-26 Operating Procedure for One-Pulse Output Function

	Operation	TAUBn Status
Restart ↑	Initial Channel Setting Set TAUBnCMORm and TAUBnCMURm registers as described in Table 13-22, TAUBnCMORm Settings for One-Pulse Output Function, and Table 13-23, TAUBnCMURm Settings for One-Pulse Output Function. Set the value of TAUBnCDRm register. Set channel output mode by setting the control bits as described in Table 13-24, Control Bit Settings in Independent Channel Output Mode 1.	Channel operation is stopped.
	Start Operation Set TAUBnTS.TAUBnTSm to 1. TAUBnTS.TAUBnTSm is a trigger bit, which is automatically cleared to 0. Detection of TAUBnTTINm start edge	TAUBnTE.TAUBnTEm is set to 1 and TAUBnCNTm waits for detection of the TAUBnTTINm start edge. When a start edge is detected, TAUBnCNTm loads the TAUBnCDRm value.
	During Operation The value of TAUBnCDRm is changeable at any time. The TAUBnCNTm register are readable at any time.	INTTAUBnIm is generated when TAUBnCNTm starts and TAUBnTTOUTm is set to its active level. TAUBnCNTm counts down. When the counter reaches 0001 _H : <ul style="list-style-type: none"> • INTTAUBnIm is generated. • TAUBnTTOUTm is set to its inactive level. TAUBnCNTm stops counting and waits for a trigger. If a trigger occurs while TAUBnCNTm is counting, the trigger is ignored.
	Stop Operation Set TAUBnTT.TAUBnTTm to 1. TAUBnTT.TAUBnTTm is a trigger bit, which is automatically cleared to 0.	TAUBnTE.TAUBnTEm is cleared to 0 and the counter stops. TAUBnCNTm and TAUBnTTOUTm stop and retain their current values

13.14 Independent Channel Signal Measurement Functions

This section describes functions that measure the widths of an individual TAUBnTTINm pulse or the total width of successive TAUBnTTINm pulses. It also describes functions that measure the interval of the signal or that compare the width of a pulse with a reference value.

- Section 13.14.1, TAUBnTTINm Input Pulse Interval Measurement Function
- Section 13.14.2, TAUBnTTINm Input Signal Width Measurement Function
- Section 13.14.3, TAUBnTTINm Input Period Count Detection Function
- Section 13.14.4, TAUBnTTINm Input Pulse Interval Judgment Function
- Section 13.14.5, TAUBnTTINm Input Signal Width Judgment Function

13.14.1 TAUBnTTINm Input Pulse Interval Measurement Function

(1) Overview

- Summary** This function captures the count value and uses this value and the overflow bit TAUBnCSRm.TAUBnOVF to measure the interval of the TAUBnTTINm input signal
- Prerequisites**
- The operating mode should be set to capture mode. See Table 13-28, TAUBnCMORm Settings for TAUBnTTINm Input Pulse Interval Measurement Function.
 - TAUBnTTOUTm is not used with this function.
- Description** The counter is started by setting the channel trigger bit (TAUBnTS.TAUBnTSm) to 1. This in turn sets TAUBnTE.TAUBnTEm = 1, enabling count operation. The counter TAUBnCNTm starts to count up from 0000_H. When a valid TAUBnTTINm edge is detected, the value of TAUBnCNTm is captured, transferred to TAUBnCDRm, and an interrupt INTTAUBnIm is generated. The counter resets to 0000_H and subsequently continues operation.
- If the counter reaches FFFF_H before a valid TAUBnTTINm edge is detected, it overflow. The counter is reset to 0000_H and subsequently continues operation. The values transferred to TAUBnCDRm and TAUBnCSRm.TAUBnOVF respectively depend on the values of bits TAUBnCMORm.TAUBnCOS[1:0].

Table 13-27 Effects of Overflow

TAUBnCMORm. COS[1:0]	When Overflow Occurs		When a Valid TAUBnTTINm Input is Detected	
	TAUBnCDRm	TAUBnCSRm.T AUBnOVF	TAUBnCDRm, TAUBnCNTm	TAUBnCSRm.T AUBnOVF
00	Unchanged	0	TAUBnCNTm loaded into TAUBnCDRm	1
01		1		
10	Set to FFFF _H	0	TAUBnCNTm set to 0, TAUBnCDRm unchanged	Unchanged
11		1		

When TAUBnCMORm.TAUBnCOS[0] = 1, the overflow bit (TAUBnCSRm.TAUBnOVF) can be cleared only by setting TAUBnCSCm.TAUBnCLOV = 1.

The combination of the value of TAUBnCDRm and TAUBnCSRm.TAUBnOVF can be used to deduce the interval of the TAUBnTTINm signal. However, if an overflow occurs multiple times before a valid TAUBnTTINm input is detected, the overflow bit TAUBnCSRm.TAUBnOVF cannot indicate the occurrence of multiple overflows.

The function can be stopped by setting TAUBnTT.TAUBnTTm = 1. This sets TAUBnTE.TAUBnTEm = 0. TAUBnCNTm stops but retains its value. While the function is stopped, valid TAUBnTTINm input edge detection and TAUBnCNTm capture are not performed.

The function can be restarted by setting TAUBnTS.TAUBnTSm = 1. The counter is reset to 0000_H and subsequently continues operation.

Conditions If the TAUBnCMORm.TAUBnMD0 bit is set to 0, the first interrupt after a start or restart is not generated. For details, see Section 13.10, TAUBnTTOUTm Output and INTTAUBnIm Generation when Counter Starts or Restarts (TAUBnMD0 bit).

Note When TAUBnCMORm.TAUBnCOS[1] = 1_B, the value of TAUBnCNTm is not loaded into TAUBnCDRm when the first valid TAUBnTTINm input edge occurs after an overflow. However, an interrupt is generated.

(2) Equations

$$\text{TAUBnTTINm input pulse interval} = \text{count clock cycle} \times [(\text{TAUBnCSRm.TAUBnOVFx} (\text{FFFF}_H+1)) + \text{TAUBnCDRm capture value} + 1]$$

(3) Block diagram and general timing diagram

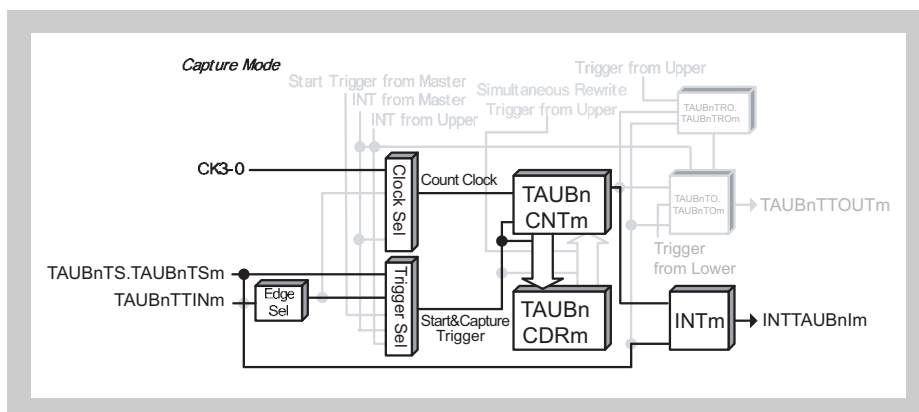

Figure 13-28 Block Diagram of TAUBnTTINm Input Pulse Interval Measurement Function

The following settings apply to the general timing diagram.

- INTTAUBnIm not generated at the beginning of operation (TAUBnCMORm.TAUBnMD0 = 0)
- Falling edge detection (TAUBnCMURm.TAUBnTIS[1:0] = 00_B)
- When a valid TAUBnTTINm input is detected after an overflow, TAUBnCDRm is changed and TAUBnCSRm.TAUBnOVF is set to 1 (TAUBnCMORm.TAUBnCOS[1:0] = 00_B)

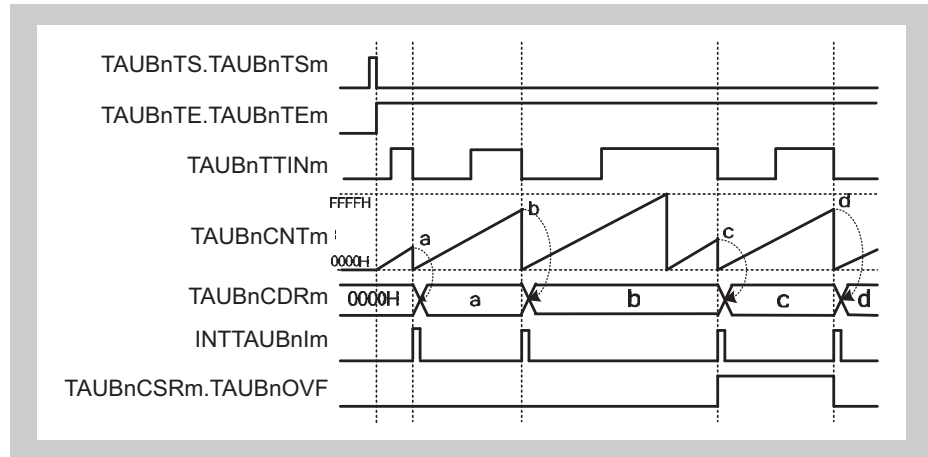

Figure 13-29 General Timing Diagram of TAUBnTTINm Input Pulse Interval Measurement Function

(4) Register settings

(a) TAUBnCMORm

15	14	13	12	11	10	9	8	7	6	5	4	3	2	1	0
TAUBnCKS [1:0]	TAUBnCCS [1:0]	TAUBnMAS	TAUBnSTS[2:0]			TAUBnCOS [1:0]	-	TAUBnMD[4:1]				TAUBnMD0			

Table 13-28 TAUBnCMORm Settings for TAUBnTTINm Input Pulse Interval Measurement Function

Bit Name	Setting
TAUBnCKS[1:0]	00: Operation clock = CK0 01: Operation clock = CK1 10: Operation clock = CK2 11: Operation clock = CK3
TAUBnCCS[1:0]	00: Uses an operation clock as a count clock.
TAUBnMAS	0: Unused. Set to 0.
TAUBnSTS[2:0]	001: Valid edge of the TAUBnTTINm input signal is the external capture trigger.
TAUBnCOS[1:0]	See Table 13-27, Effects of Overflow.
TAUBnMD[4:1]	0010: Capture mode
TAUBnMD0	0: INTTAUBnIm not generated at the beginning of operation. 1: INTTAUBnIm generated at the beginning of operation.

(b) TAUBnCMURm

7	6	5	4	3	2	1	0
-						TAUBnTIS[1:0]	

Table 13-29 TAUBnCMURm Settings for TAUBnTTINm Input Pulse Interval Measurement Function

Bit Name	Setting
TAUBnTIS[1:0]	00: Detection of falling edge 01: Detection of rising edge 10: Detection of falling and rising edges

(c) Channel output mode

TAUBnTOE.TAUBnTOEm is set to 0 because the channel output mode is not used with this function. However, this mode can be used in independent channel output mode controlled by software.

(d) Simultaneous rewrite

The simultaneous rewrite registers (TAUBnRDE, TAUBnRDS, TAUBnRDM, and TAUBnRDC) cannot be used with the TAUBnTTINm input pulse interval measurement function. Therefore, these registers should be set to 0.

Table 13-30 Simultaneous Rewrite Settings for TAUBnTTINm Input Pulse Interval Measurement Function

Bit Name	Setting
TAUBnRDE.TAUBnRDEm	0: Disables simultaneous rewrite.
TAUBnRDS.TAUBnRDSm	0: When disabling simultaneous rewrite (TAUBnRDE.TAUBnRDEm = 0), set these bits to 0.
TAUBnRDM.TAUBnRDMm	
TAUBnRDC.TAUBnRDCm	

(5) Operating procedure for TAUBnTTINm input pulse interval measurement function

Table 13-31 Operating Procedure for TAUBnTTINm Input Pulse Interval Measurement Function

	Operation	TAUBn Status
Initial Channel Setting	Set TAUBnCMORm and TAUBnCMURm registers as described in Table 13-28, TAUBnCMORm Settings for TAUBnTTINm Input Pulse Interval Measurement Function, and Table 13-29, TAUBnCMURm Settings for TAUBnTTINm Input Pulse Interval Measurement Function. TAUBnCDRm register operates as a capture register.	Channel operation is stopped.
Start Operation	Set TAUBnTS.TAUBnTSm to 1. TAUBnTS.TAUBnTSm is a trigger bit, which is automatically cleared to 0.	TAUBnTE.TAUBnTEm is set to 1 and the counter starts. TAUBnCNTm is cleared to 0000 _H . INTTAUBnIm is generated when TAUBnCMORm.MD0 is set to 1.
During Operation	Detection of TAUBnTTINm edges The TAUBnCMURm.TAUBnTIS[1:0] bits can be changed at any time. The TAUBnCDRm and TAUBnCSRm registers can be read at any time. TAUBnCSCm.TAUBnCLOV can be written to 1. (TAUBnCSRm.TAUBnOVF bit is cleared to 0.)	TAUBnCNTm starts to count up from 0000 _H . When a TAUBnTTINm valid edge is detected: <ul style="list-style-type: none"> TAUBnCNTm transfers (captures) its value to TAUBnCDRm, and returns to 0000_H. INTTAUBnIm is then generated. Afterwards, this procedure is repeated.
Stop Operation	Set TAUBnTT.TAUBnTTm to 1. TAUBnTT.TAUBnTTm is a trigger bit, which is automatically cleared to 0.	TAUBnTE.TAUBnTEm is cleared to 0 and the counter stops. TAUBnCNTm stops and both it and TAUBnCSRm.TAUBnOVF retain their current values.

Restart

(6) Specific timing diagrams: overflow operation**(a) TAUBnCMORm.TAUBnCOS[1:0] = 00_B**

Figure 13-30 TAUBnCMORm.TAUBnCOS[1:0] = 00_B, TAUBnCMORm.TAUBnMD0 = 0, TAUBnCMURm.TAUBnTIS[1:0] = 00_B

- When an overflow occurs, the value of TAUBnCDRm remains unchanged and TAUBnCSRm.TAUBnOVF remains = 0.
- Upon detection of the next valid TAUBnTTINm input edge, the value of TAUBnCNTm is loaded into TAUBnCDRm and TAUBnCSRm.TAUBnOVF is set to 1.
- Upon detection of the next valid TAUBnTTINm input edge with no overflow occurring, TAUBnCSRm.TAUBnOVF is cleared to 0.

(b) TAUBnCMORm.TAUBnCOS[1:0] = 01_B

Figure 13-31 TAUBnCMORm.TAUBnCOS[1:0] = 01_B, TAUBnCMORm.TAUBnMD0 = 0, TAUBnCMURm.TAUBnTIS[1:0] = 00_B

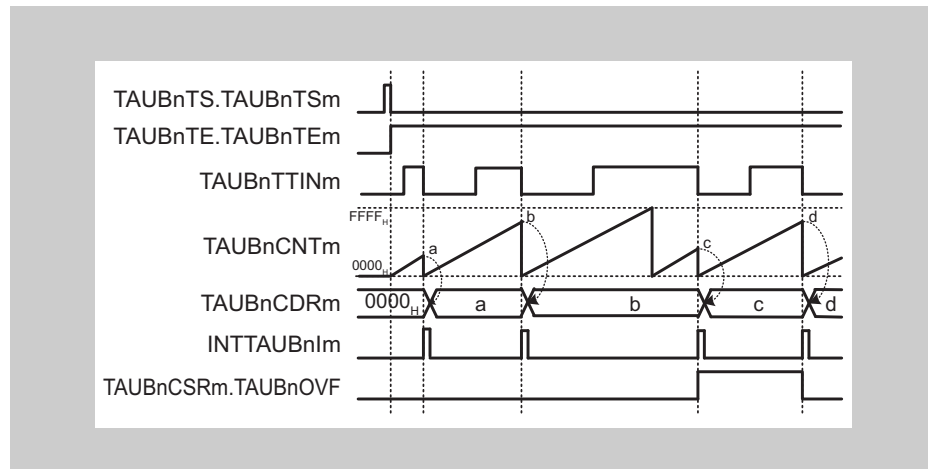
- When an overflow occurs, the value of TAUBnCDRm remains unchanged and TAUBnCSRm.TAUBnOVF is set to 1.
- Upon detection of the next valid TAUBnTTINm input edge, the value of TAUBnCNTm is loaded into TAUBnCDRm.
- TAUBnCSRm.TAUBnOVF is cleared by setting TAUBnCSCm.TAUBnCLOV bit to 1.

(c) $\text{TAUBnCMORm.TAUBnCOS}[1:0] = 10_{\text{B}}$ 

Figure 13-32 $\text{TAUBnCMORm.TAUBnCOS}[1:0] = 10_{\text{B}}$, $\text{TAUBnCMORm.TAUBnMD0} = 0$,
 $\text{TAUBnCMURm.TAUBnTIS}[1:0] = 00_{\text{B}}$

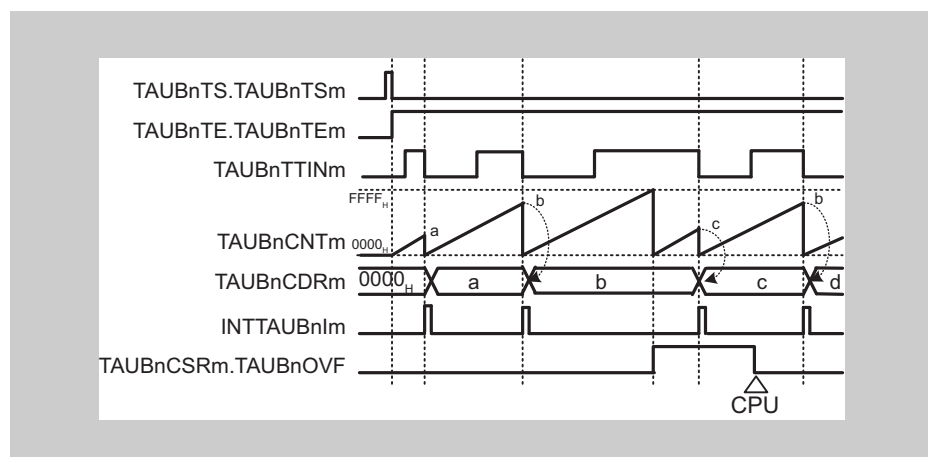
- When an overflow occurs, TAUBnCDRm is set to FFFF_{H} and $\text{TAUBnCSRm.TAUBnOVF}$ remains = 0.
- Upon detection of the next valid TAUBnTTINm input edge, TAUBnCNTm is reset to 0, but TAUBnCDRm and $\text{TAUBnCSRm.TAUBnOVF}$ remain unchanged.
- Thus, the next valid TAUBnTTINm input edge after the overflow is ignored.

(d) $\text{TAUBnCMORm.TAUBnCOS}[1:0] = 11_{\text{B}}$ 

Figure 13-33 $\text{TAUBnCMORm.TAUBnCOS}[1:0] = 11_{\text{B}}$, $\text{TAUBnCMORm.TAUBnMD0} = 0$,
 $\text{TAUBnCMURm.TAUBnTIS}[1:0] = 00_{\text{B}}$

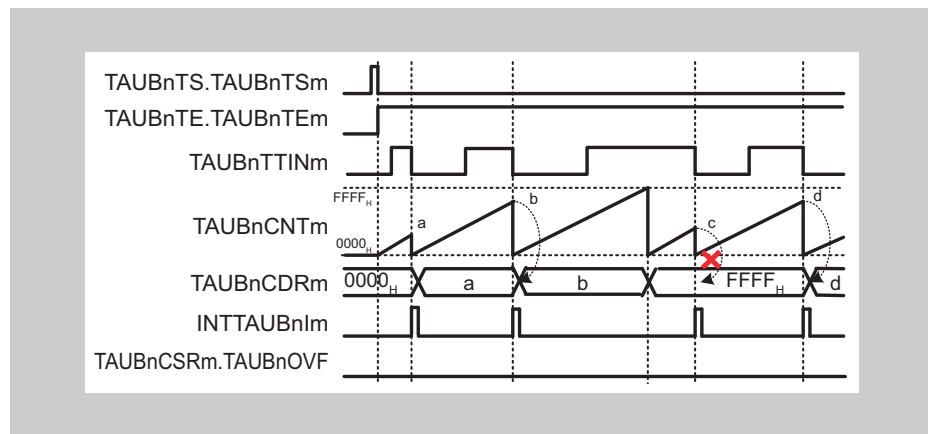
- When an overflow occurs, TAUBnCDRm is set to FFFF_{H} and $\text{TAUBnCSRm.TAUBnOVF}$ is set to 1.
- Upon detection of the next valid TAUBnTTINm input edge, TAUBnCNTm is reset to 0, but TAUBnCDRm and $\text{TAUBnCSRm.TAUBnOVF}$ remain unchanged.
- Thus, the next valid TAUBnTTINm input edge after the overflow is ignored.
- $\text{TAUBnCSRm.TAUBnOVF}$ is cleared by setting $\text{TAUBnCSCm.TAUBnCLOV}$ to 1.

13.14.2 TAUBnTTINm Input Signal Width Measurement Function

(1) Overview

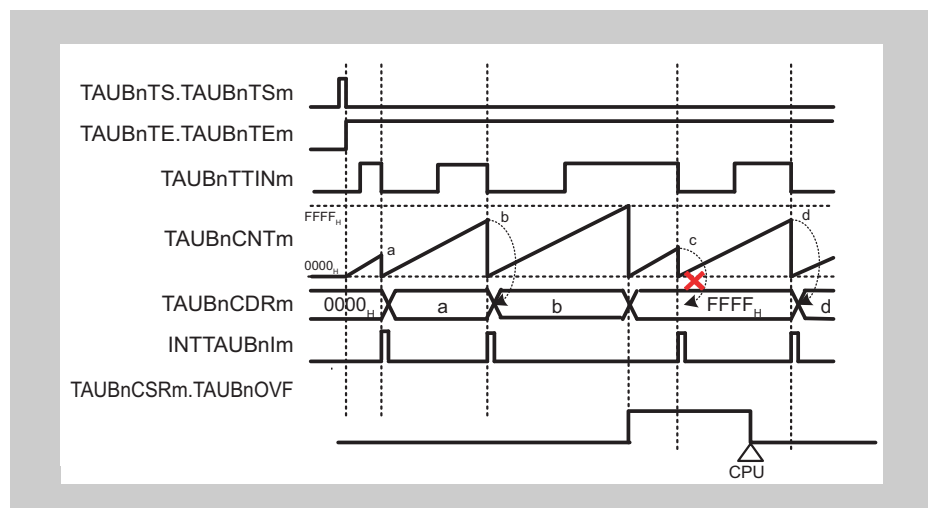
Summary This function measures the width of a TAUBnTTINm input signal.

- Prerequisites**
- The operating mode should be set to capture and one-count mode. See Table 13-33, TAUBnCMORm Settings for TAUBnTTINm Input Signal Width Measurement Function.
 - TAUBnTTOUTm is not used with this function.
 - TAUBnCMORm.TAUBnMD0 should be set to 0.

Description The counter is started by setting the channel trigger bit (TAUBnTS.TAUBnTSM) to 1. This in turn sets TAUBnTE.TAUBnTEM = 1, enabling count operation. When a valid TAUBnTTINm start edge is detected, the counter TAUBnCNTm starts to count up from 0000_H. When a valid TAUBnTTINm stop edge is detected, the value of TAUBnCNTm is captured, transferred to TAUBnCDRm, and an interrupt INTTAUBnIm is generated. The counter retains its value and awaits the next valid TAUBnTTINm input start edge.

If the counter reaches FFFF_H before a valid TAUBnTTINm stop edge is detected, it overflows. The counter is reset to 0000_H and subsequently continues operation. The values transferred to TAUBnCDRm and TAUBnCSRm.TAUBnOVF respectively depend on the values of bits TAUBnCMORm.TAUBnCOS[1:0].

Table 13-32 Effects of Overflow

TAUBnCMORm. COS[1:0]	When Overflow Occurs		When a Valid TAUBnTTINm Input Stop Edge is Detected	
	TAUBnCDRm	TAUBnCSRm. TAUBnOVF	TAUBnCDRm, TAUBnCNTm	TAUBnCSRm. TAUBnOVF
00	Unchanged	0	TAUBnCNTm loaded into TAUBnCDRm	1
01		1		
10	Set to FFFF _H	0	TAUBnCNTm stops counting TAUBnCDRm unchanged	Unchanged
11		1		

When TAUBnCMORm.TAUBnCOS[0] = 1, overflow bit TAUBnCSRm.TAUBnOVF can be cleared only by setting TAUBnCSCm.TAUBnCLOV to 1.

The combination of the value of TAUBnCDRm and TAUBnCSRm.TAUBnOVF can be used to deduce the width of the TAUBnTTINm signal. However, if an overflow occurs multiple times before a valid TAUBnTTINm input is detected, overflow bit TAUBnCSRm.TAUBnOVF cannot indicate the occurrence of multiple overflows.

This function cannot be forcibly restarted.

Note When TAUBnCMORm.TAUBnCOS[1]=1, the value of TAUBnCNTm is not loaded into TAUBnCDRm when the first valid TAUBnTTINm input edge occurs after an overflow. However, an interrupt is generated.

(2) Equations

$$\text{TAUBnTTINm input signal width} = \text{count clock cycle} \times [(\text{TAUBnCSRm.TAUBnOVF} \times (\text{FFFF}_H + 1)) + \text{TAUBnCDRm capture value} + 1]$$

(3) Block diagram and general timing diagram

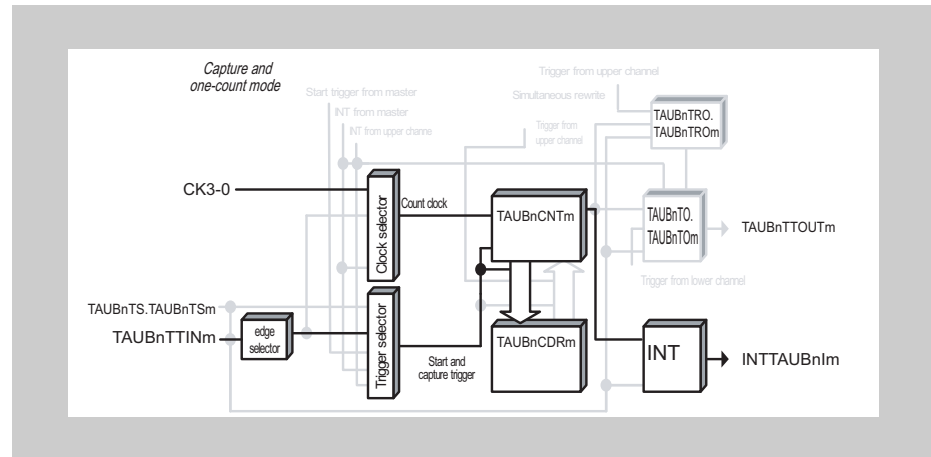

Figure 13-34 Block Diagram of TAUBnTTINm Input Signal Width Measurement Function

The following settings apply to the general timing diagram.

- Detection of falling and rising edges = High width measurement (TAUBnCMURm.TAUBnTIS[1:0] = 11_B)
- When a valid TAUBnTTINm input is detected after an overflow, TAUBnCDRm is changed and TAUBnCSRm.TAUBnOVF is set to 1. (TAUBnCMORm.TAUBnCOS[1:0] = 00_B)

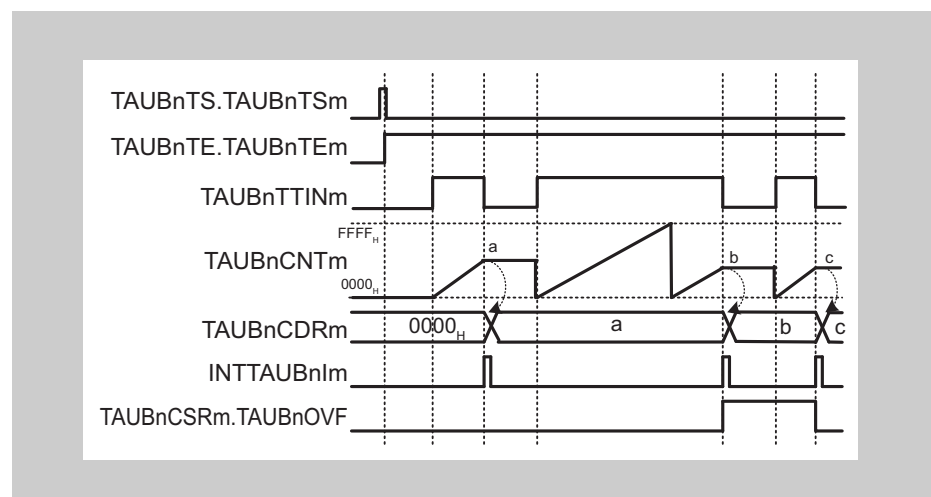

Figure 13-35 General Timing Diagram of TAUBnTTINm Input Signal Width Measurement Function

(4) Register settings

(a) TAUBnCMORm

15	14	13	12	11	10	9	8	7	6	5	4	3	2	1	0
TAUBnCKS [1:0]	TAUBnCCS [1:0]	TAUBnMAS	TAUBnSTS[2:0]			TAUBnCOS [1:0]	-	TAUBnMD[4:1]				TAUBnMD0			

Table 13-33 TAUBnCMORm Settings for TAUBnTTINm Input Signal Width Measurement Function

Bit Name	Setting
TAUBnCKS[1:0]	00: Operation clock = CK0 01: Operation clock = CK1 10: Operation clock = CK2 11: Operation clock = CK3
TAUBnCCS[1:0]	00: Uses an operation clock as a count clock.
TAUBnMAS	0: Unused. Set to 0.
TAUBnSTS[2:0]	010: Valid edge of the TAUBnTTINm input signal is used as an external start trigger and the reverse edge as a stop trigger.
TAUBnCOS[1:0]	See Table 13-32, Effects or Overflow.
TAUBnMD[4:1]	0110: Capture and one-count mode
TAUBnMD0	0: Disables the start trigger during operation.

(b) TAUBnCMURm

7	6	5	4	3	2	1	0
-						TAUBnTIS[1:0]	

Table 13-34 TAUBnCMURm Settings for TAUBnTTINm Input Signal Width Measurement Function

Bit Name	Setting
TAUBnTIS[1:0]	10: Detection of falling and rising edges (Low width measurement) 11: Detection of falling and rising edges (High width measurement)

(c) Channel output mode

TAUBnTOE.TAUBnTOEm is set to 0 because the channel output mode is not used with this function. However, this mode can be used in independent channel output mode controlled by software.

(d) Simultaneous rewrite

The simultaneous rewrite registers (TAUBnRDE, TAUBnRDS, TAUBnRDM, and TAUBnRDC) cannot be used with the TAUBnTTINm input signal width measurement function. Therefore, these registers should be set to 0.

Table 13-35 Simultaneous Rewrite Settings for TAUBnTTINm Input Signal Width Measurement Function

Bit Name	Setting
TAUBnRDE.TAUBnRDEm	0:Disables simultaneous rewrite.
TAUBnRDS.TAUBnRDSm	0: When disabling simultaneous rewrite (TAUBnRDE.TAUBnRDEm = 0), set these bits to 0.
TAUBnRDM.TAUBnRDMm	
TAUBnRDC.TAUBnRDCm	

(5) Operating procedure for TAUBnTTINm input signal width measurement function

Table 13-36 Operating Procedure for TAUBnTTINm Input Signal Width Measurement Function

	Operation	TAUBn Status
Initial Channel Setting	Set TAUBnCMORm and TAUBnCMURm registers as described in Table 13-33, TAUBnCMORm Settings for TAUBnTTINm Input Signal Width Measurement Function, and Table 13-34, TAUBnCMURm Settings for TAUBnTTINm Input Signal Width Measurement Function. TAUBnCDRm register operates as a capture register.	Channel operation is stopped.
Start Operation	Set TAUBnTS.TAUBnTSm to 1. TAUBnTS.TAUBnTSm is a trigger bit, which is automatically cleared to 0.	TAUBnTE.TAUBnTEm is set to 1 and TAUBnCNTm waits for detection of TAUBnTTINm start edge. When a TAUBnTTINm start edge is detected, TAUBnCNTm starts to count up.
During Operation	Detection of TAUBnTTINm edges TAUBnCDRm, TAUBnCNTm, and TAUBnCSRm registers can be read at any time. TAUBnCSC.TAUBnCLOV bit can be set to 1.	TAUBnCNTm starts to count up from 0000 _H . When TAUBnTTINm valid edge is detected: <ul style="list-style-type: none"> TAUBnCNTm transfers (captures) its value to TAUBnCDRm, and retains its value. Counting stops at the "value transferred to TAUBnCDRm + 1" value and TAUBnCNTm waits for detection of the TAUBnTTINm start edge. Afterwards, this procedure is repeated.
Stop Operation	Set TAUBnTT.TAUBnTTm to 1. TAUBnTT.TAUBnTTm is a trigger bit, which is automatically cleared to 0.	TAUBnTE.TAUBnTEm is cleared to 0 and the counter stops. TAUBnCNTm stops and both it and TAUBnCSRm.TAUBnOVF retain their current values.

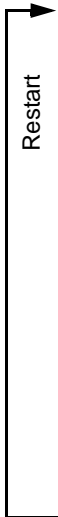

(6) Specific timing diagrams: overflow operation**(a) TAUBnCMORm.TAUBnCOS[1:0] = 00_B**

Figure 13-36 TAUBnCMORm.TAUBnCOS[1:0] = 00_B, TAUBnCMORm.TAUBnMD0 = 0, TAUBnCMURm.TAUBnTIS[1:0] = 11_B

- When an overflow occurs, the value of TAUBnCDRm remains unchanged and TAUBnCSRm.TAUBnOVF remains = 0.
- Upon detection of the next valid TAUBnTTINm input edge, the value of TAUBnCNTm is loaded into TAUBnCDRm and TAUBnCSRm.TAUBnOVF is set to 1.
- Upon detection of the next valid TAUBnTTINm input edge with no overflow occurring, TAUBnCSRm.TAUBnOVF is cleared to 0.

(b) TAUBnCMORm.TAUBnCOS[1:0] = 01_B

Figure 13-37 TAUBnCMORm.TAUBnCOS[1:0] = 01_B, TAUBnCMORm.TAUBnMD0 = 0, TAUBnCMURm.TAUBnTIS[1:0] = 11_B

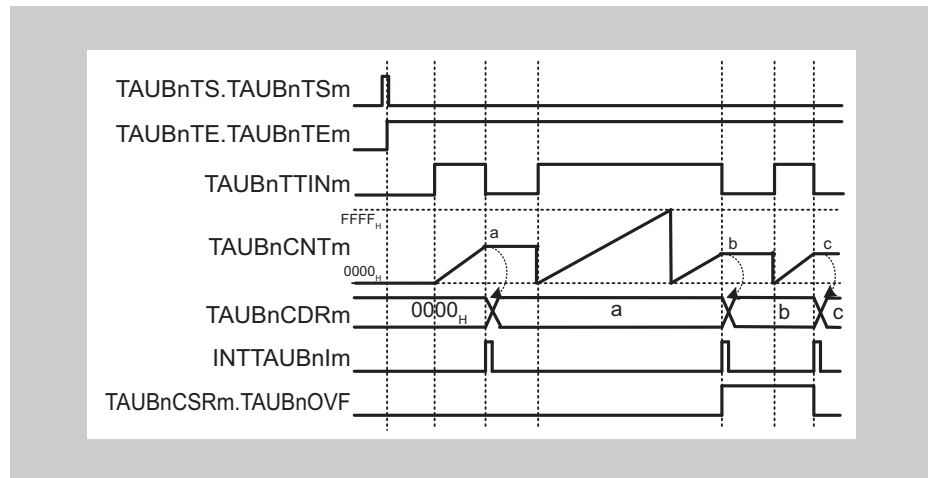
- When an overflow occurs, the value of TAUBnCDRm remains unchanged and TAUBnCSRm.TAUBnOVF is set to 1.
- Upon detection of the next valid TAUBnTTINm input edge, the value of TAUBnCNTm is loaded into TAUBnCDRm.
- TAUBnCSRm.TAUBnOVF is cleared by setting TAUBnCSCm.TAUBnCLOV bit to 1.

(c) TAUBnCMORm.TAUBnCOS[1:0] = 10_B

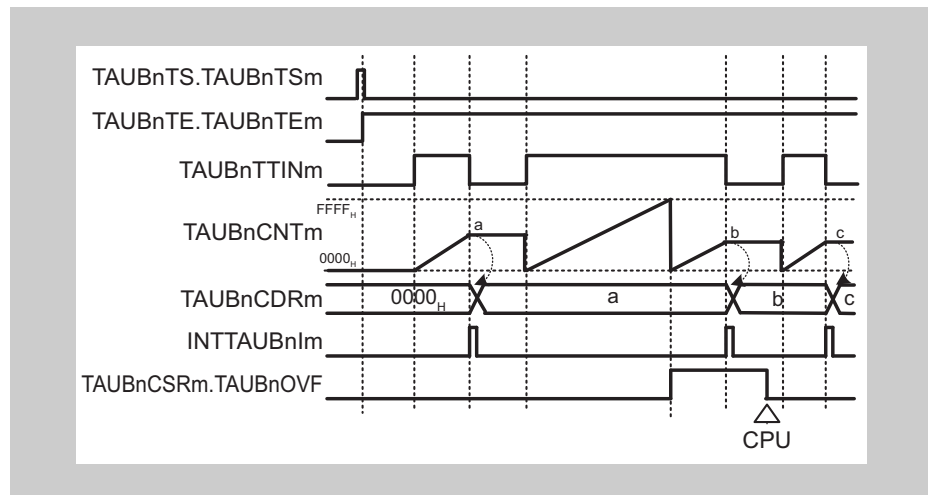
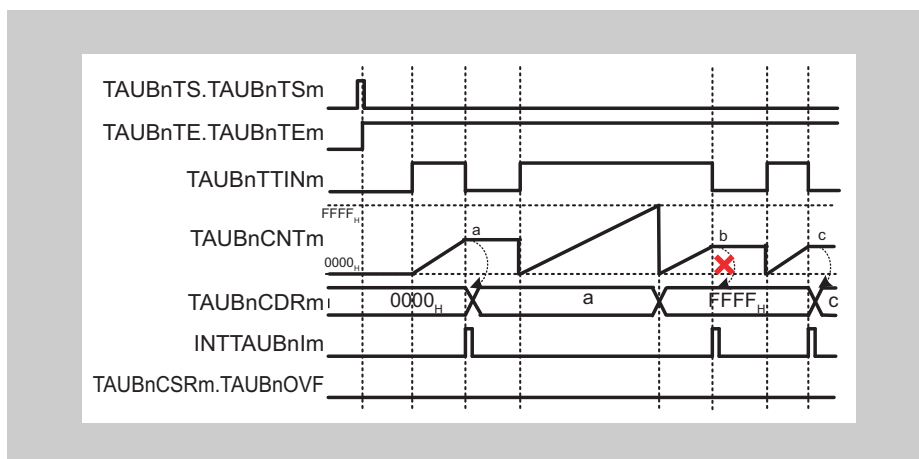

Figure 13-38 TAUBnCMORm.TAUBnCOS[1:0] = 10_B, TAUBnCMORm.TAUBnMD0 = 0, TAUBnCMURm.TAUBnTIS[1:0] = 11_B

- When an overflow occurs, TAUBnCDRm is set to FFFF_H and TAUBnCSRm.TAUBnOVF remains = 0.
- Upon detection of the next valid TAUBnTTINm input edge, TAUBnCNTm is reset to 0, but TAUBnCDRm and TAUBnCSRm.TAUBnOVF remain unchanged.
- Thus, the next TAUBnTTINm input valid edge after the overflow is ignored.

(d) $\text{TAUBnCMORm.TAUBnCOS}[1:0] = 11_{\text{B}}$ 

Figure 13-39 $\text{TAUBnCMORm.TAUBnCOS}[1:0] = 11_{\text{B}}$, $\text{TAUBnCMORm.TAUBnMD0} = 0$,
 $\text{TAUBnCMURm.TAUBnTIS}[1:0] = 11_{\text{B}}$

- When an overflow occurs, TAUBnCDRm is set to FFFF_{H} and $\text{TAUBnCSRm.TAUBnOVF}$ is set to 1.
- Upon detection of the next valid TAUBnTTINm input edge, TAUBnCNTm is reset to 0, but TAUBnCDRm and $\text{TAUBnCSRm.TAUBnOVF}$ remain unchanged.
- Thus, the next valid TAUBnTTINm input edge after the overflow is ignored.
- $\text{TAUBnCSRm.TAUBnOVF}$ is cleared by setting $\text{TAUBnCSCm.TAUBnCLOV}$ to 1.

13.14.3 TAUBnTTINm Input Period Count Detection Function

(1) Overview

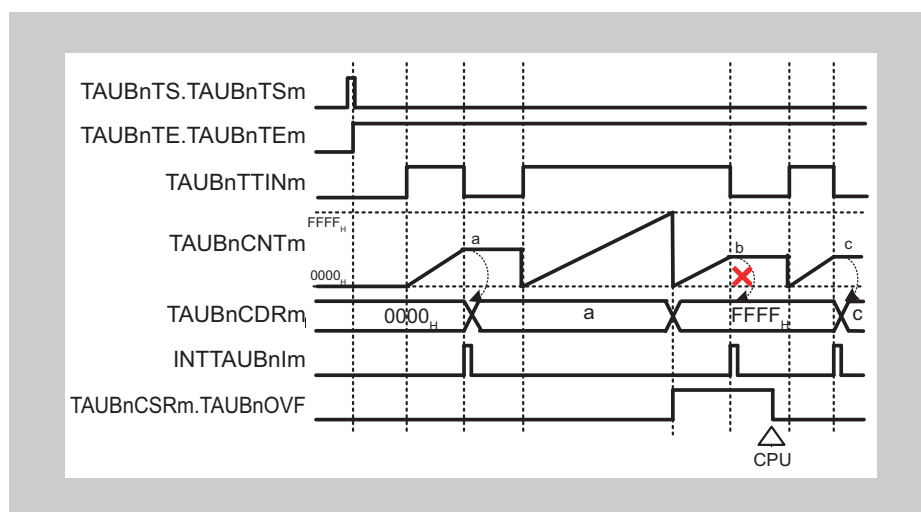
- Summary** This function measures the cumulative width of a TAUBnTTINm input signal.
- Prerequisites**
- The operating mode should be set to capture and gate count mode. (See Table 13-37, TAUBnCMORm Settings for TAUBnTTINm Input Period Count Detection Function.)
 - TAUBnTTOUTm is not used with this function.
- Description**
- The counter is enabled by setting the channel trigger bit (TAUBnTS.TAUBnTSM) to 1. This in turn sets TAUBnTE.TAUBnTEM = 1, enabling count operation. The counter awaits a valid TAUBnTTINm input edge.
- When a valid TAUBnTTINm input start edge is detected, the counter starts to count from 0000_H.
- When a valid TAUBnTTINm input stop edge is detected, the current TAUBnCNTm value is loaded into TAUBnCDRm and an interrupt (INTTAUBnIm) is generated. The counter stops and retains its value until the next valid TAUBnTTINm input start edge is detected.
- When the next valid TAUBnTTINm input start edge is detected, the counter restarts to count from the value retained when stopped.
- If the counter reaches FFFF_H, the counter restarts to count from 0000_H.
- Note** TAUBnTTINm input signal is sampled at the frequency of a sampling clock set by the TAUBnCMORm.TAUBnCKS[1:0] bits.
- Conditions** The valid start and stop edges are specified by the TAUBnCMURm.TAUBnTIS[1:0] bits:
- If TAUBnCMURm.TAUBnTIS[1:0] = 10_B, the TAUBnTTINm input low period is measured. The start trigger is a falling edge and the stop trigger is a rising edge.
 - If TAUBnCMURm.TAUBnTIS[1:0] = 11_B, the TAUBnTTINm input high period is measured. The start trigger is a rising edge and the stop trigger is a falling edge.

(2) Equations

Cumulative TAUBnTTINm input width = count clock cycle × (TAUBnCDRm capture value + 1)

(3) Block diagram and general timing diagram

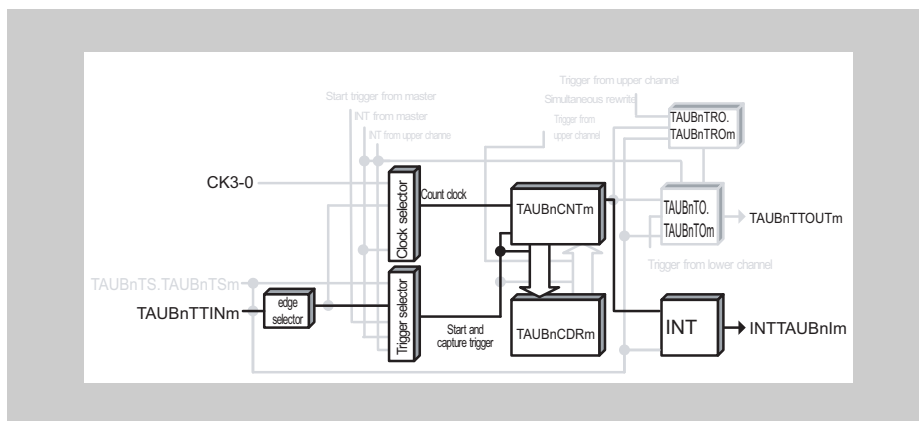

Figure 13-40 Block Diagram of TAUBnTTINm Input Period Count Detection Function

The following settings apply to the general timing diagram.

- Detection of falling and rising edges = High width measurement (TAUBnCMURm.TAUBnTIS[1:0] = 11_B)

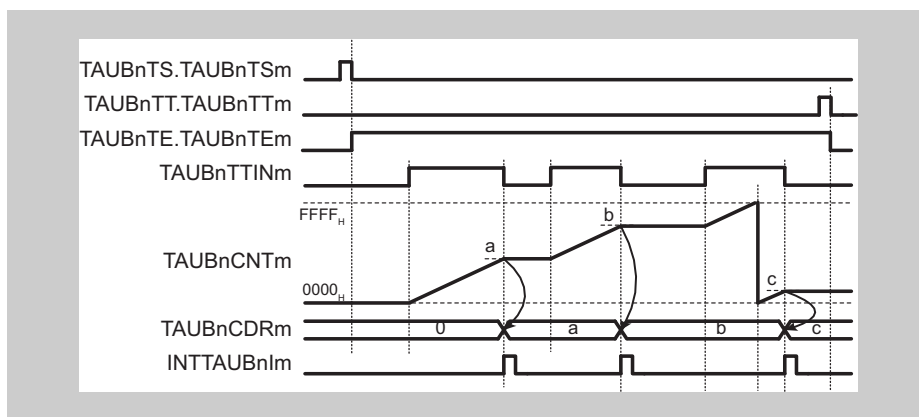

Figure 13-41 General Timing Diagram of TAUBnTTINm Input Period Count Detection Function

(4) Register settings

(a) TAUBnCMORM

15	14	13	12	11	10	9	8	7	6	5	4	3	2	1	0
TAUBnCKS [1:0]	TAUBnCCS [1:0]	TAUBnMAS	TAUBnSTS[2:0]			TAUBnCOS [1:0]	-	TAUBnMD[4:1]				TAUBnMD0			

Table 13-37 TAUBnCMORM Settings for TAUBnTTINm Input Period Count Detection Function

Bit Name	Setting
TAUBnCKS[1:0]	00: Operation clock = CK0 01: Operation clock = CK1 10: Operation clock = CK2 11: Operation clock = CK3
TAUBnCCS[1:0]	00: Uses an operation clock as a count clock.
TAUBnMAS	0: Unused. Set to 0.
TAUBnSTS[2:0]	010: Valid edge of the TAUBnTTINm input signal is used as an external start trigger and the reverse edge as a stop trigger.
TAUBnCOS[1:0]	01: Set this value.
TAUBnMD[4:1]	1101: Capture and gate count mode
TAUBnMD0	0: Disables a start trigger during operation.

(b) TAUBnCMURm

7	6	5	4	3	2	1	0
-						TAUBnTIS[1:0]	

Table 13-38 TAUBnCMURm Settings for TAUBnTTINm Input Period Count Detection Function

Bit Name	Setting
TAUBnTIS[1:0]	10: Detection of falling and rising edges (Low width measurement) 11: Detection of falling and rising edges (High width measurement)

(c) Channel output mode

TAUBnTOE.TAUBnTOEm is set to 0 because the channel output mode is not used with this function. However, this mode can be used in independent channel output mode controlled by software.

(d) Simultaneous rewrite

Simultaneous rewrite registers (TAUBnRDE, TAUBnRDS, TAUBnRDM, and TAUBnRDC) cannot be used with this function. Therefore, these registers should be set to 0.

Table 13-39 Simultaneous Rewrite Settings for TAUBnTTINm Input Period Count Detection Function

Bit Name	Setting
TAUBnRDE.TAUBnRDEm	0: Disables simultaneous rewrite.
TAUBnRDS.TAUBnRDSm	0: When disabling simultaneous rewrite (TAUBnRDE.TAUBnRDEm = 0), set these bits to 0.
TAUBnRDM.TAUBnRDMm	
TAUBnRDC.TAUBnRDCm	

(5) Operating procedure for TAUBnTTINm input period count detection function

Table 13-40 Operating Procedure for TAUBnTTINm Input Period Count Detection Function

	Operation	TAUBn Status
Restart	Initial Channel Setting Set TAUBnCMORm and TAUBnCMURm registers as described in Table 13-37, TAUBnCMORm Settings for TAUBnTTINm Input Period Count Detection Function, and Table 13-38, TAUBnCMURm Settings for TAUBnTTINm Input Period Count Detection Function. TAUBnCDRm register operates as a capture register.	Channel operation is stopped.
	Start Operation Set TAUBnTS.TAUBnTSm to 1. TAUBnTS.TAUBnTSm is a trigger bit, which is automatically cleared to 0. Detection of TAUBnTTINm start edge	TAUBnTE.TAUBnTEm is set to 1 and TAUBnCNTm waits for detection of the TAUBnTTINm start edge. When a start edge is detected, TAUBnCNTm is cleared to 0000 _H and starts counting up.
	During Operation Detection of TAUBnTTINm edges The TAUBnCDRm, TAUBnCNTm, and TAUBnCSRm registers can be read at any time.	When a TAUBnTTINm start edge (rising edge for high width measurement, falling edge for low width measurement) is detected, TAUBnCNTm starts counting up from the stop value. When TAUBnCNTm detects a stop edge (falling edge for high width measurement, rising edge for low width measurement), it transfers the value to TAUBnCDRm and INTTAUBnIm is generated. Counting stops at the "value transferred to TAUBnCDRm + 1" and TAUBnCNTm waits for detection of the TAUBnTTINm start edge. When TAUBnCNTm reaches FFFF _H , the counter restarts to count from 0000 _H . Afterwards, this procedure is repeated.
	Stop Operation Set TAUBnTT.TAUBnTTm to 1. TAUBnTT.TAUBnTTm is a trigger bit, which is automatically cleared to 0.	TAUBnTE.TAUBnTEm is cleared to 0 and the counter stops. TAUBnCNTm stops. TAUBnCNTm remains its current value.

(6) Specific timing diagrams
 (a) Operation stop and restart

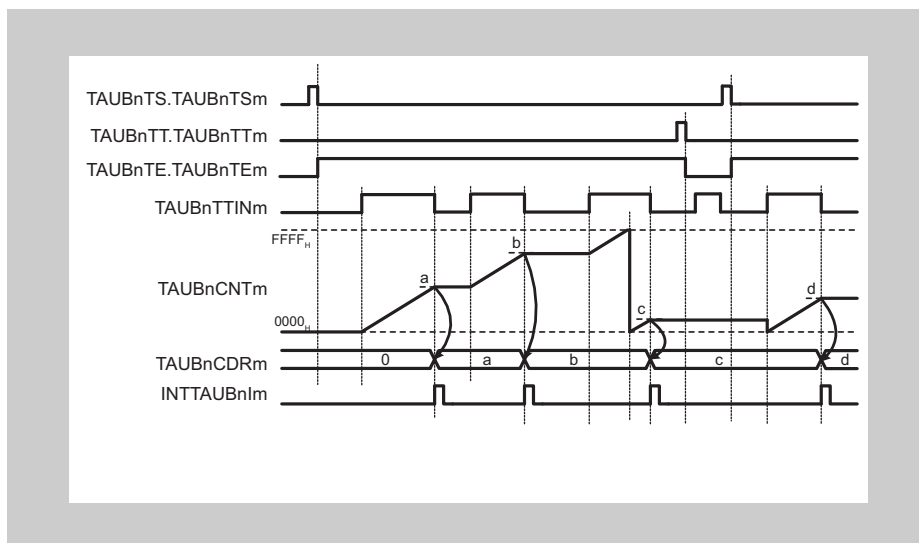

Figure 13-42 Operation Stop and Restart (TAUBnCMURm.TAUBnTIS[1:0] = 11_B)

- The counter can be stopped by setting TAUBnTT.TAUBnTTm to 1. This sets TAUBnTE.TAUBnTEm to 0.
- TAUBnCNTm stops and the current value is retained.
- If the counter is stopped, valid TAUBnTTINm input edges are ignored.
- The counter can be restarted by setting TAUBnTS.TAUBnTSm to 1. TAUBnCNTm restarts to count from 0000_H.

13.14.4 TAUBnTTINm Input Pulse Interval Judgment Function

(1) Overview

- Summary** This function outputs the result of a comparison between the count value (TAUBnCNTm) and the value in the channel data register (TAUBnCDRm) when a TAUBnTTINm input pulse occurs. An interrupt signal INTTAUBnIm is generated if the result of the comparison is true.
- Prerequisites**
- The operating mode should be set to judge mode. See Table 13-41, TAUBnCMORm Settings for TAUBnTTINm Input Pulse Interval Judgment Function.
 - TAUBnTTOUTm is not used with this function.
- Description** The counter is started by setting the channel trigger bit (TAUBnTS.TAUBnTSm) to 1. This in turn sets TAUBnTE.TAUBnTEm = 1, enabling count operation. The current value of TAUBnCDRm is loaded into TAUBnCNTm and the counter starts to count down from this value.
- When a TAUBnTTINm valid edge is detected or TAUBnTS.TAUBnTSm is set to 1, the function compares the current values of TAUBnCNTm and TAUBnCDRm. An interrupt signal INTTAUBnIm is generated if the result of the comparison is true. TAUBnCNTm reloads the value of TAUBnCDRm and subsequently continues operation, regardless of the result of the comparison.
- If the counter reaches 0000_H before a TAUBnTTINm valid edge is detected, TAUBnCNTm underflows and is set to FFFF_H. It then continues to count down.
- The value of TAUBnCDRm can be rewritten at any time, and the changed value of TAUBnCDRm is applied the next time the counter starts to count down.
- Conditions** The TAUBnCMORm.TAUBnMD0 bit specifies the type of comparison:
- If TAUBnCMORm.TAUBnMD0 = 0, INTTAUBnIm is generated when TAUBnCNTm ≤ TAUBnCDRm.
 - If TAUBnCMORm.TAUBnMD0 = 1, INTTAUBnIm is generated when TAUBnCNTm > TAUBnCDRm

(2) Block diagram and general timing diagram

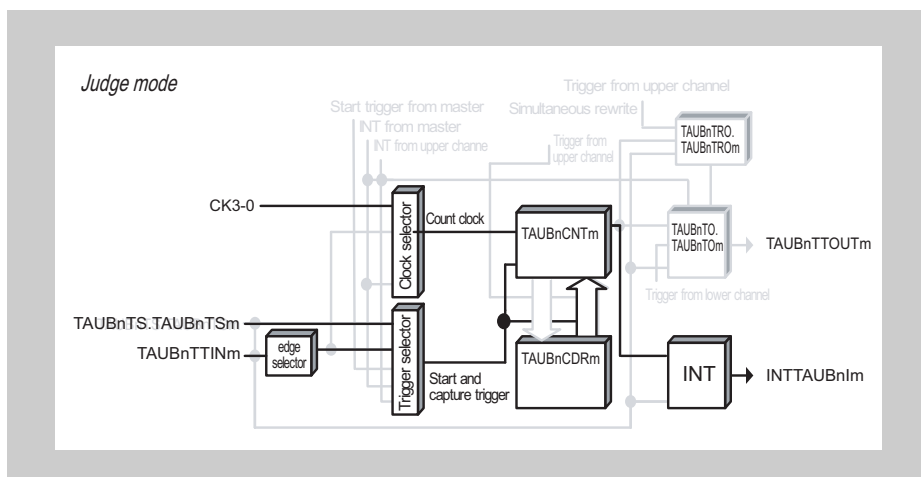

Figure 13-43 Block Diagram of TAUBnTTINm Input Pulse Interval Judgment Function

The following settings apply to the general timing diagram.

- Detection of falling edge (TAUBnCMURm.TAUBnTIS[1:0] = 00_B)

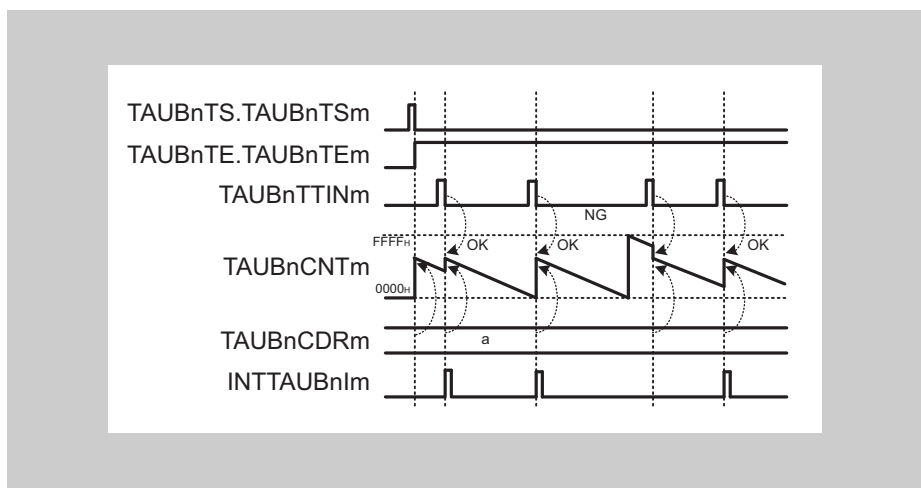

Figure 13-44 General Timing Diagram of TAUBnTTINm Input Pulse Interval Judgment Function

(3) Register settings

(a) TAUBnCMORm

15	14	13	12	11	10	9	8	7	6	5	4	3	2	1	0
TAUBnCKS [1:0]		TAUBnCCS [1:0]		TAUBnMAS	TAUBnSTS[2:0]		TAUBnCOS [1:0]		-	TAUBnMD[4:1]				TAUBnMDO	

Table 13-41 TAUBnCMORm Settings for TAUBnTTINm Input Pulse Interval Judgment Function

Bit Name	Setting
TAUBnCKS[1:0]	00: Operation clock = CK0 01: Operation clock = CK1 10: Operation clock = CK2 11: Operation clock = CK3
TAUBnCCS[1:0]	00: Uses an operation clock as a count clock.
TAUBnMAS	0: Unused. Set to 0.
TAUBnSTS[2:0]	001: Valid edge of the TAUBnTTINm input signal is used as an external start trigger.
TAUBnCOS[1:0]	00: Unused. Set to 00.
TAUBnMD[4:1]	0001: Judge mode
TAUBnMDO	0: INTTAUBnIm is generated when TAUBnCNTm ≤ TAUBnCDRm 1: INTTAUBnIm is generated when TAUBnCNTm > TAUBnCDRm

(b) TAUBnCMURm

7	6	5	4	3	2	1	0
-						TAUBnTIS[1:0]	

Table 13-42 TAUBnCMURm Settings for TAUBnTTINm Input Pulse Interval Judgment Function

Bit Name	Setting
TAUBnTIS[1:0]	00: Detection of falling edge 01: Detection of rising edge 10: Detection of falling and rising edges

(c) Channel output mode

TAUBnTOE.TAUBnTOEm is set to 0 because the channel output mode is not used with this function. However, this mode can be used in independent channel output mode controlled by software.

(d) Simultaneous rewrite

Simultaneous rewrite registers (TAUBnRDE, TAUBnRDS, TAUBnRDM, and TAUBnRDC) cannot be used with this function. Therefore, these registers should be set to 0.

Table 13-43 Simultaneous Rewrite Settings for TAUBnTTINm Input Pulse Interval Judgment Function

Bit Name	Setting
TAUBnRDE.TAUBnRDEm	0: Disables simultaneous rewrite.
TAUBnRDS.TAUBnRDSm	0: When disabling simultaneous rewrite (TAUBnRDE.TAUBnRDEm = 0), set these bits to 0.
TAUBnRDM.TAUBnRDMm	
TAUBnRDC.TAUBnRDCm	

(4) Operating procedure for TAUBnTTINm input pulse interval judgment function

Table 13-44 Operating Procedure for TAUBnTTINm Input Pulse Interval Judgment Function

	Operation	TAUBn Status
Restart ↑	Initial Channel Setting	Channel operation is stopped.
	Start Operation	TAUBnTE.TAUBnTEm is set to 1 and the counter starts. TAUBnCDRm value is loaded into TAUBnCNTm.
	During Operation	TAUBnCNTm counts down. When a TAUBnTTINm input edge is detected: <ul style="list-style-type: none"> • TAUBnCNTm reloads TAUBnCDRm value and continues count operation. • TAUBnCNTm compares the values and judges the condition according to the TAUBnCMORm.TAUBnMD0 setting. • If the condition is satisfied, INTTAUBnIm is generated. Afterwards, this procedure is repeated.
	Stop Operation	TAUBnTE.TAUBnTEm is cleared to 0 and the counter stops. TAUBnCNTm stops and retains its current value.

13.14.5 TAUBnTTINm Input Signal Width Judgment Function

(1) Overview

- Summary** This function outputs the result of a comparison between the count value (TAUBnCNTm) and the value in the channel data register (TAUBnCDRm) when a valid stop edge of a TAUBnTTINm input signal is detected. An interrupt signal INTTAUBnIm is generated if the result of the comparison is true.
- Prerequisites**
- The operating mode should be set to judge and one-count mode. (See Table 13-45, TAUBnCMORm Settings for TAUBnTTINm Input Signal Width Judgment Function.)
 - TAUBnTTOUTm is not used with this function.
- Description** The counter is started by setting the channel trigger bit (TAUBnTS.TAUBnTSm) to 1. This in turn sets TAUBnTE.TAUBnTEm = 1, enabling count operation. When a valid TAUBnTTINm input start edge is detected, the current value of TAUBnCDRm is loaded into TAUBnCNTm and the counter starts to count down from this value.
- When a TAUBnTTINm valid stop edge is detected, the function compares the current values of TAUBnCNTm and TAUBnCDRm. An interrupt signal INTTAUBnIm is generated if the result of the comparison is true. The counter TAUBnCNTm retains its value until the next valid TAUBnTTINm start edge is detected, regardless of the result of the comparison.
- If the counter reaches 0000_H before a valid TAUBnTTINm stop edge is detected, TAUBnCNTm underflows and is set to FFFF_H. The counter then continues to count down.
- The value of TAUBnCDRm can be rewritten at any time, and the changed value of TAUBnCDRm is applied the next time the counter starts to count down.
- Conditions**
- The TAUBnCMORm.TAUBnMD0 bit specifies the type of comparison:
 - If TAUBnCMORm.TAUBnMD0 = 0, INTTAUBnIm is generated when TAUBnCNTm ≤ TAUBnCDRm.
 - If TAUBnCMORm.TAUBnMD0 = 1, INTTAUBnIm is generated when TAUBnCNTm > TAUBnCDRm.
 - The TAUBnCMURm.TAUBnTIS[1:0] bits specify a type of width measurement:
 - For high width measurement (TAUBnCMURm.TAUBnTIS[1:0] = 11_B), TAUBnTTINm rising edge is used as a start edge and TAUBnTTINm falling edge as a stop edge.
 - For low width measurement (TAUBnCMURm.TAUBnTIS[1:0] = 10_B), TAUBnTTINm falling edge is used as a start edge and TAUBnTTINm rising edge as a stop edge.
 - This function cannot make a forced restart.

(2) Block diagram and general timing diagram

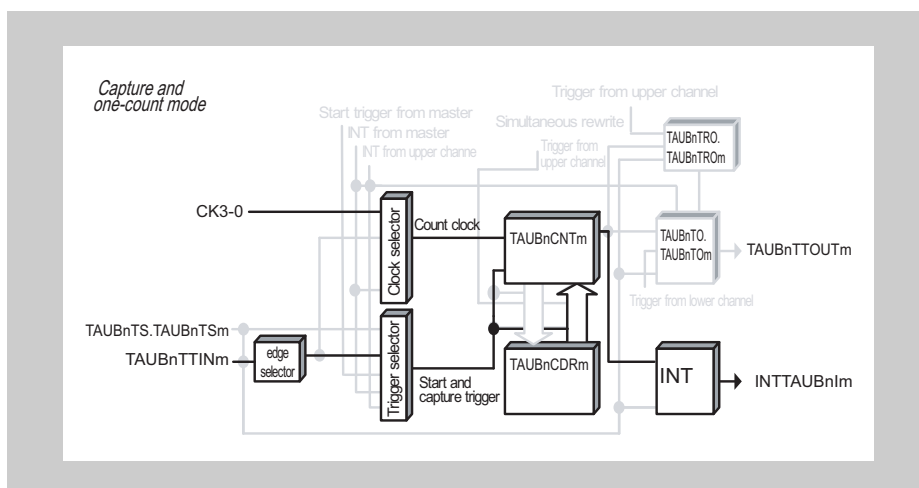

Figure 13-45 Block Diagram of TAUBnTTINm Input Signal Width Judgment Function

The following settings apply to the general timing diagram.

- INTTAUBnIm is generated when $TAUBnCNTm \leq TAUBnCDRm$ ($TAUBnCMORm.TAUBnMD0 = 0$)
- TAUBnTTINm valid start edge = rising edge, TAUBnTTINm valid stop edge = falling edge ($TAUBnCMURm.TAUBnTIS[1:0] = 11_B$)

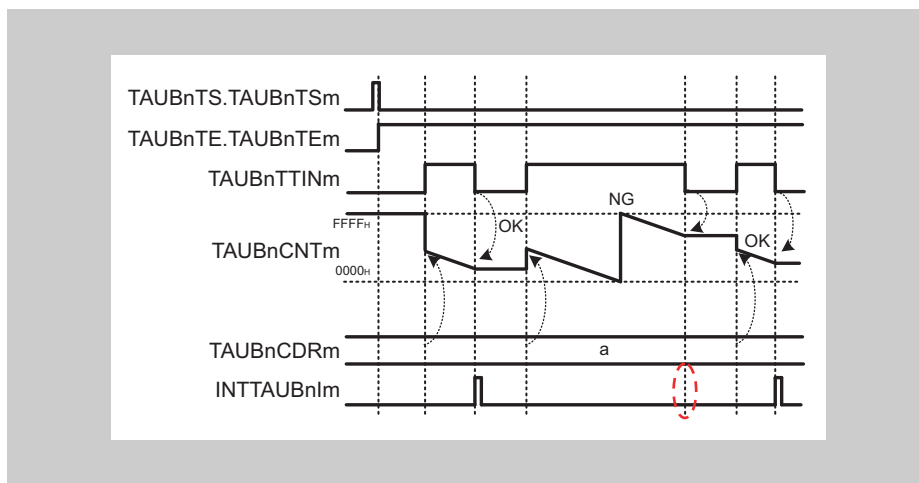

Figure 13-46 General Timing Diagram of TAUBnTTINm Input Signal Width Judgment Function

(3) Register settings

(a) TAUBnCMORm

15	14	13	12	11	10	9	8	7	6	5	4	3	2	1	0
TAUBnCKS [1:0]	TAUBnCCS [1:0]	TAUBnMAS	TAUBnSTS[2:0]			TAUBnCOS [1:0]		-	TAUBnMD[4:1]				TAUBnMD0		

Table 13-45 TAUBnCMORm Settings for TAUBnTTINm Input Signal Width Judgment Function

Bit Name	Setting
TAUBnCKS[1:0]	00: Operation clock = CK0 01: Operation clock = CK1 10: Operation clock = CK2 11: Operation clock = CK3
TAUBnCCS[1:0]	00: Uses an operation clock as a count clock.
TAUBnMAS	0: Unused. Set to 0.
TAUBnSTS[2:0]	010: Valid edge of the TAUBnTTINm input signal is used as an external start trigger and the reverse edge as a stop trigger.
TAUBnCOS[1:0]	00: Unused. Set to 00.
TAUBnMD[4:1]	0111: Judge and one-count mode
TAUBnMD0	0: INTTAUBnIm is generated when TAUBnCNTm ≤ TAUBnCDRm 1: INTTAUBnIm is generated when TAUBnCNTm > TAUBnCDRm

(b) TAUBnCMURm

7	6	5	4	3	2	1	0
-						TAUBnTIS[1:0]	

Table 13-46 TAUBnCMURm Settings for TAUBnTTINm Input Signal Width Judgment Function

Bit Name	Setting
TAUBnTIS[1:0]	10: Detection of falling and rising edges (Low width measurement) 11: Detection of falling and rising edges (High width measurement)

(c) Channel output mode

TAUBnTOE.TAUBnTOEm is set to 0 because the channel output mode is not used with this function. However, this mode can be used in independent channel output mode controlled by software.

(d) Simultaneous rewrite

Simultaneous rewrite registers (TAUBnRDE, TAUBnRDS, TAUBnRDM, and TAUBnRDC) cannot be used with this function. Therefore, these registers should be set to 0.

Table 13-47 Simultaneous Rewrite Settings for TAUBnTTINm Input Signal Width Judgment Function

Bit Name	Setting
TAUBnRDE.TAUBnRDEm	0: Disables simultaneous rewrite.
TAUBnRDS.TAUBnRDSm	0: When disabling simultaneous rewrite (TAUBnRDE.TAUBnRDEm = 0), set these bits to 0.
TAUBnRDM.TAUBnRDMm	
TAUBnRDC.TAUBnRDCm	

(4) Operating procedure for TAUBnTTINm input signal width judgment function

Table 13-48 Operating Procedure for TAUBnTTINm Input Signal Width Judgment Function

	Operation	TAUBn Status
Restart ↓	Initial Channel Setting Set TAUBnCMORm and TAUBnCMURm registers as described in Table 13-45, TAUBnCMORm Settings for TAUBnTTINm Input Signal Width Judgment Function, and Table 13-46, TAUBnCMURm Settings for TAUBnTTINm Input Signal Width Judgment Function. Set the value of TAUBnCDRm register.	Channel operation is stopped.
	Start Operation Set TAUBnTS.TAUBnTSm to 1. TAUBnTS.TAUBnTSm is a trigger bit, which is automatically cleared to 0. Detection of TAUBnTTINm start edge	TAUBnTE.TAUBnTEm is set to 1 and TAUBnCNTm waits for detection of TAUBnTTINm start edge. When a TAUBnTTINm start edge is detected, TAUBnCDRm value is loaded into TAUBnCNTm.
	During Operation Detection of TAUBnTTINm edge The value of TAUBnCDRm can be changed at any time. The TAUBnCNTm register can be read at any time.	TAUBnCNTm counts down. When TAUBnTTINm stop edge is detected: <ul style="list-style-type: none"> • TAUBnCNTm stops and waits for detection of TAUBnTTINm start edge. • TAUBnCNTm compares the values and judges the condition according to the TAUBnCMORm.TAUBnMD0 setting. • If the condition is satisfied, INTTAUBnIm is generated. Afterwards, this procedure is repeated.
	Stop Operation Set TAUBnTT.TAUBnTTm to 1. TAUBnTT.TAUBnTTm is a trigger bit, which is automatically cleared to 0.	TAUBnTE.TAUBnTEm is cleared to 0 and the counter stops. TAUBnCNTm stops and retains its current value.

13.15 Independent Channel Simultaneous Rewrite Functions

This section describes functions that carry out simultaneous rewrite.

- Section 13.15.1, Simultaneous Rewrite Trigger Generation Function Type 1

13.15.1 Simultaneous Rewrite Trigger Generation Function Type 1

(1) Overview

- Summary** This function generates an interrupt on a specific channel that can be used by lower channels as a simultaneous rewrite trigger. The interrupt is generated at regular intervals.
- The upper channel is a channel which generates a simultaneous rewrite trigger (TAUBnRDC.TAUBnRDCm = 1), and the lower channel is a channel which makes a simultaneous rewrite in response to the upper channel trigger (TAUBnRDC.TAUBnRDCm = 0).
- Prerequisites**
- Two or more channels lower than the channel used as upper channel are enabled for simultaneous rewrite (TAUBnRDE.RDEm = 1).
 - The operating mode for the upper channel should be set to interval timer mode. (See Table 13-49, TAUBnCMORm Settings for Simultaneous Rewrite Trigger Generation Function Type 1.)
 - For the operating mode that can be set for lower channels, see Table 13-9, Simultaneous Rewrite and Trigger Timing.
 - TAUBnTTOUTm is not used for any channel in this function.
- Description**
- The counter operation is enabled by setting the channel trigger bits (TAUBnTS.TAUBnTSM) for upper and lower channels to 1. This sets TAUBnTE.TAUBnTEM = 1, enabling count operation. The current value of the data register buffer for upper channels (TAUBnCDRm buf) is loaded into the counter (TAUBnCNTm) and the counter starts to count down from this value. The counter for lower channels start to count according to the selected operating mode.
- Once the counter reaches 0000_H, an interrupt occurs on the channel. The current value of the corresponding TAUBnCDRm buffer is loaded into TAUBnCNTm to continue operation subsequently.
- If the channel where an interrupt occurs is specified as a trigger channel for simultaneous rewrite (TAUBnRDC.RDCm = 1) and is an upper channel, simultaneous rewrite takes place on all lower channels in which simultaneous rewrite is currently possible (TAUBnRSF.RSFm = 1).
- The values of the data registers are copied to the corresponding data register buffers. Each time a counter starts to count down, it reads the value in the data register buffer and counts down from this value.
- The value of a data register can be changed at any time, but it is only transferred to the corresponding data register buffer when simultaneous rewrite occurs.
- Conditions**
- The channel which is monitored for INTTAUBnIm occurrence is specified by setting TAUBnRDC.TAUBnRDCm = 1 for the corresponding channel. The TAUBnRDC.TAUBnRDCm bit should be 0 for all other channels in which simultaneous rewrite should take place.
 - If the TAUBnCMORm.TAUBnMD0 bit is set to 0, the first interrupt after a start or restart is not generated. For details, see Section 13.10, TAUBnTTOUTm Output and INTTAUBnIm Generation when Counter Starts or Restarts (TAUBnMD0 bit).

(2) Equations

Simultaneous rewrite trigger generation cycle = count clock cycle x (TAUBnCDRm + 1)

To control simultaneous rewrite, the following condition should be satisfied:

[PWM]

TAUBnCDRm = [(value of TAUBnCDRm of master channel subject to simultaneous rewrite + 1) x number of interrupts] - 1

[Triangle PWM]

TAUBnCDRm = [(value of TAUBnCDRm of master channel subject to simultaneous rewrite + 1) x 2 x number of interrupts] - 1

That is, the ratio of TAUBnCDRm + 1 and TAUBnCDRm_master + 1 should be an integer. This integer corresponds to the number of interrupts.

For triangle PWM, remember that the cycle doubles.

(3) Block diagram and general timing diagram

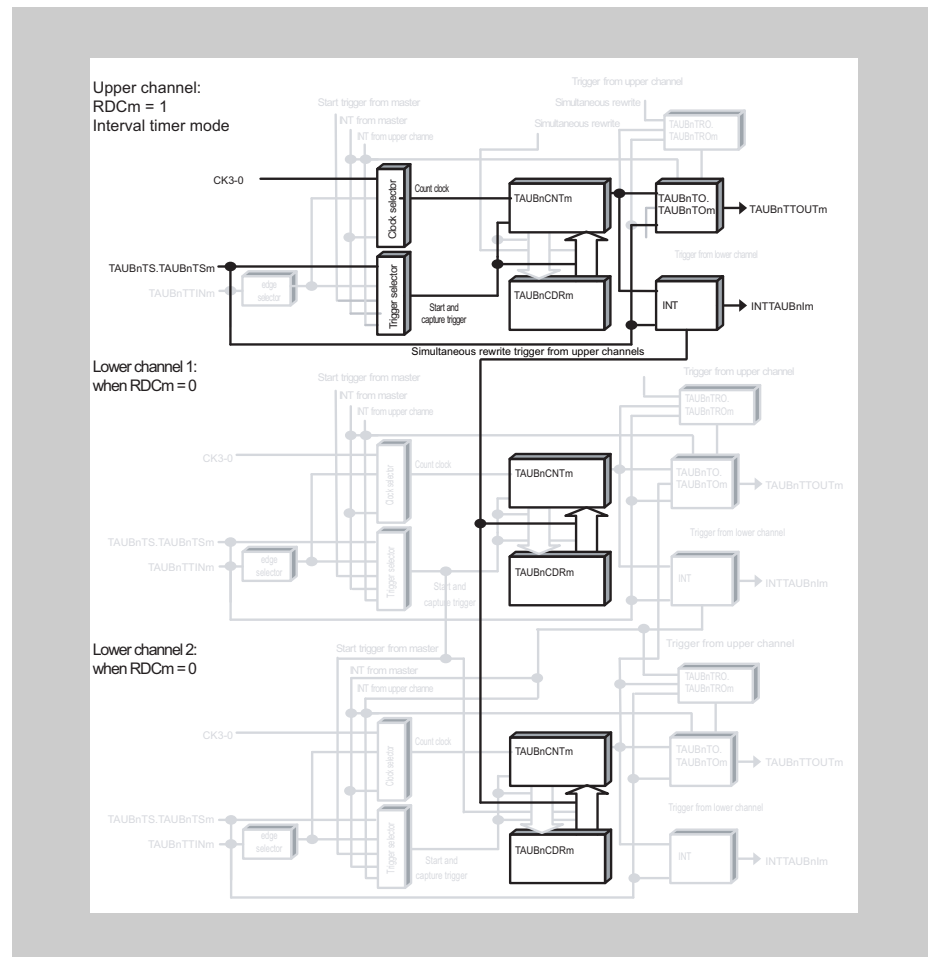

Figure 13-47 Block Diagram of Simultaneous Rewrite Trigger Generation Function Type 1

The following settings apply to the general timing diagram.

- INTTAUBn1m is generated at the beginning of operation. (TAUBnCMORm.TAUBnMD0 = 1)

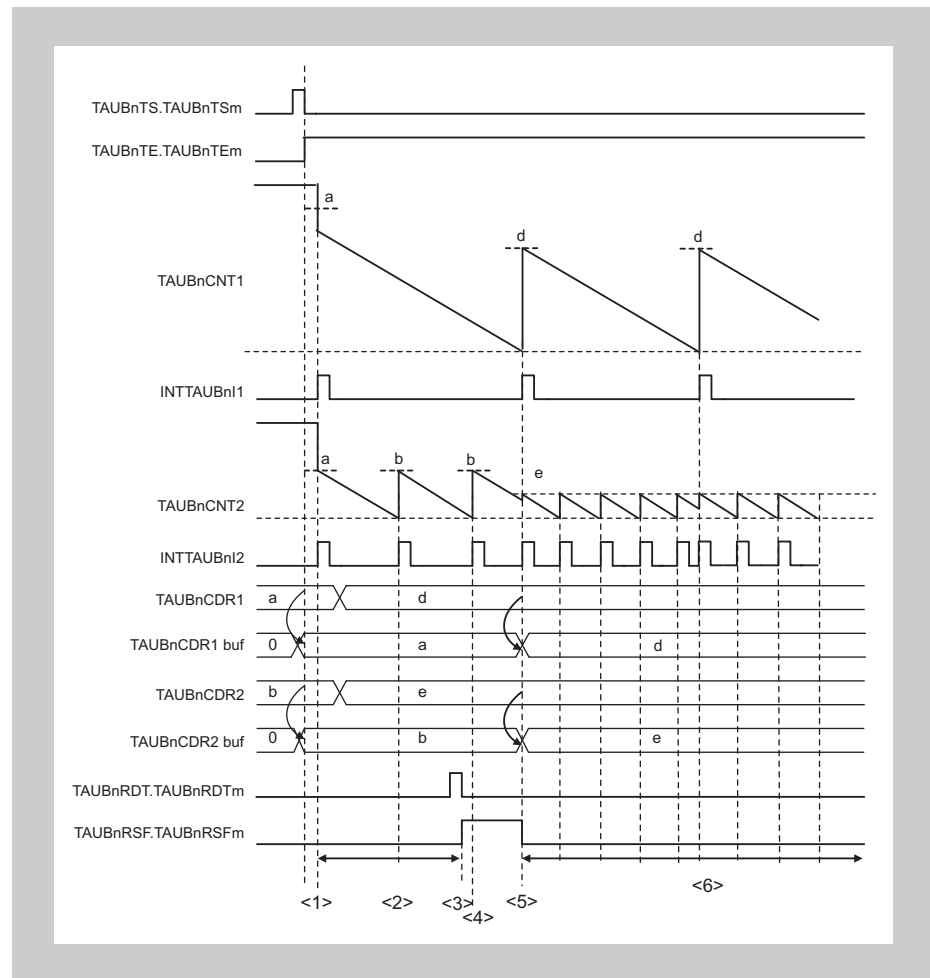

Figure 13-48 Block Diagram of Simultaneous Rewrite Trigger Generation Function Type 1

- Description:**
1. When TAUBnTS.TAUBnTSm = 1 is set, the value of TAUBnCDRm is copied to the TAUBnCDRm buffer.
 2. The TAUBnCDRm registers can be written at any time.
 3. The reload data trigger bit (TAUBnRDT.TAUBnRDTm) is set to 1 which sets the status flag (TAUBnRSF.TAUBnRSFm = 1), enabling simultaneous rewrite.
 4. Simultaneous rewrite is triggered only by a CH1 interrupt. Therefore, simultaneous rewrite is not conducted even if enabled.
 5. Simultaneous rewrite is triggered by INTTAUBn1 which is generated when TAUBnCNT1 reaches 0000_H. The TAUBnCDRm values are loaded into the corresponding TAUBnCDRm buffers.
 6. The counter counts down and awaits the next simultaneous rewrite trigger. The values of the TAUBnCDRm registers can be rechanged.

(4) Register settings for upper channels**(a) TAUBnCMORm for upper channels**

15	14	13	12	11	10	9	8	7	6	5	4	3	2	1	0
TAUBnCKS [1:0]	TAUBnCCS [1:0]	TAUB nMAS	TAUBnSTS[2:0]		TAUBnCOS [1:0]	-		TAUBnMD[4:1]				TAUB nMD0			

Table 13-49 TAUBnCMORm Settings for Simultaneous Rewrite Trigger Generation Function Type 1

Bit Name	Setting
TAUBnCKS[1:0]	00: Operation clock = CK0 01: Operation clock = CK1 10: Operation clock = CK2 11: Operation clock = CK3
TAUBnCCS[1:0]	00: Uses an operation clock as a count clock.
TAUBnMAS	0: Unused. Set to 0.
TAUBnSTS[2:0]	000: Triggers the counter by software.
TAUBnCOS[1:0]	00: Unused. Set to 00.
TAUBnMD[4:1]	0000: Interval timer mode
TAUBnMD0	0: INTTAUBnIm is not generated at the beginning of operation. 1: INTTAUBnIm is generated at the beginning of operation.

(b) TAUBnCMURm for upper channels

7	6	5	4	3	2	1	0
-							TAUBnTIS[1:0]

Table 13-50 TAUBnCMURm Settings for Simultaneous Rewrite Trigger Generation Function Type 1

Bit Name	Setting
TAUBnTIS[1:0]	00: Unused. Set to 00.

(c) Channel output mode for upper channels

TAUBnTOE.TAUBnTOEm is set to 0 because the channel output mode is not used with this function. However, this mode can be used in independent channel output mode controlled by software.

(d) Simultaneous rewrite for upper channels**Table 13-51 Simultaneous Rewrite Settings for Simultaneous Rewrite Trigger Generation Function Type 1**

Bit Name	Setting
TAUBnRDE.TAUBnRDEm	1: Enables simultaneous rewrite.
TAUBnRDS.TAUBnRDSm	1: Selects one of upper channels as simultaneous rewrite control channel.
TAUBnRDM.TAUBnRDMm	0: Loads a simultaneous rewrite control signal when the master channel starts to count.
TAUBnRDC.TAUBnRDCm	1: Monitors INTTAUBnIm signal which triggers a simultaneous rewrite on the channel.

(5) Register settings for lower channels**(a) TAUBnCMORm for lower channels**

TAUBnCMORm register for lower channels must follow the TAUBnCMORm register settings in the operating mode which can be set. See Table 13-9, Simultaneous Rewrite and Trigger Timing.

(b) TAUBnCMURm for lower channels

TAUBnCMURm register for lower channels must follow the TAUBnCMURm register settings in the operating mode which can be set. See Table 13-9, Simultaneous Rewrite and Trigger Timing.

(c) Channel output mode for lower channels

Output can be made according to the operating mode setting (master/slave) for lower channels.

(d) Simultaneous rewrite for lower channels**Table 13-52 Simultaneous Rewrite Settings for Lower Channels in Simultaneous Rewrite Trigger Generation Function Type 1**

Bit Name	Setting
TAUBnRDE.TAUBnRDEm	1: Enables simultaneous rewrite.
TAUBnRDS.TAUBnRDSm	1: Selects one of upper channels as simultaneous rewrite control channel.
TAUBnRDM.TAUBnRDMm	0: Loads a simultaneous rewrite control signal when the master channel starts to count.
TAUBnRDC.TAUBnRDCm	0: Not monitor INTTAUBnIm signal which triggers a simultaneous rewrite on the channel.

(6) Operating procedure for simultaneous rewrite trigger generation function type 1

Table 13-53 Operating Procedure for Simultaneous Rewrite Trigger Generation Function Type 1

	Operation	TAUBn Status
Restart	Initial Channel Setting	Channel operation is stopped.
	Start Operation	TAUBnTE.TAUBnTEm is set to 1 and the counter starts. TAUBnCDRm value is loaded into TAUBnCNTm. If TAUBnCMORm.TAUBnMD0 = 1, INTTAUBnIm occurs.
	During Operation	TAUBnRDT.TAUBnRDTm and TAUBnCDR.CDRm is changeable. TAUBnRSF.TAUBnRSFm can be always read. TAUBnCNTm counts down. When the counter reaches 0000 _H : <ul style="list-style-type: none"> The TAUBnCDRm value is reloaded into TAUBnCNTm to continue count operation. INTTAUBnIm occurs. If INTAUBnIm occurs on the channel where TAUBnRDC.TAUBnRDCm is set to 1, simultaneous rewrite is controlled. Afterwards, this procedure is repeated.
	Stop Operation	TAUBnTE.TAUBnTEm is cleared to 0 and the counter stops. TAUBnCNTm stops and retains its current value.

13.16 Other Independent Channel Functions

This section describes a function that generates an interrupt when a certain number of TAUBnTTINm pulses has occurred, a function that divides the frequency of TAUBnTTINm, and a function that measures the duration between the function start and a TAUBnTTINm input signal.

- Section 13.16.1, External Event Count Function
- Section 13.16.2, Clock Divide Function
- Section 13.16.3, TAUBnTTINm Input Position Detection Function

13.16.1 External Event Count Function

(1) Overview

- Summary** This function is used as an event timer. It generates an interrupt (INTTAUBnIm) when a specific number of TAUBnTTINm input pulses has occurred.
- Prerequisites**
- The operation mode must be set to event count mode. (Refer to Table 13-54, TAUBnCMORm Settings for External Event Count Function.)
 - TAUBnTTOUTm is not used for this function.
- Description** The counter is enabled by setting the channel trigger bit (TAUBnTS.TAUBnTSm) to 1. This in turn sets TAUBnTE.TAUBnTEm=1, enabling count operation. When the counter starts, the current value of TAUBnCDRm is loaded into TAUBnCNTm.
- When a valid TAUBnTTINm input edge is detected, the value of TAUBnCNTm is decremented. TAUBnCNTm retains this value until a valid TAUBnTTINm input edge is detected or the counter is restarted.
- When the counter value reaches 0000H, INTTAUBnIm is generated. TAUBnCNTm then reloads the TAUBnCDRm value and subsequently continues operation.
- The counter can be stopped by setting TAUBnTT.TAUBnTTm to 1, which in turn sets TAUBnTE.TAUBnTEm to 0. TAUBnCNTm stops and retains its value. The counter can be restarted by setting TAUBnTS.TAUBnTSm to 1. The counter can also be restarted without stopping it first (forced restart) by setting TAUBnTS.TAUBnTSm to 1 during operation.
- The value of TAUBnCDRm can be rewritten at any time, and the changed value of TAUBnCDRm is applied the next time the counter starts to count down.
- Conditions** The type of edge used as the trigger is specified by the TAUBnCMURm.TAUBnTIS[1:0] bits.
- If TAUBnCMURm.TAUBnTIS[1:0] = 00_B, the falling edges are counted.
 - If TAUBnCMURm.TAUBnTIS[1:0] = 01_B, the rising edges are counted.
 - If TAUBnCMURm.TAUBnTIS[1:0] = 10_B, the rising and falling edges are counted.

(2) Equations

Number of valid edges detected before INTTAUBnIm is generated =
TAUBnCDRm + 1

(3) Block diagram and general timing diagram

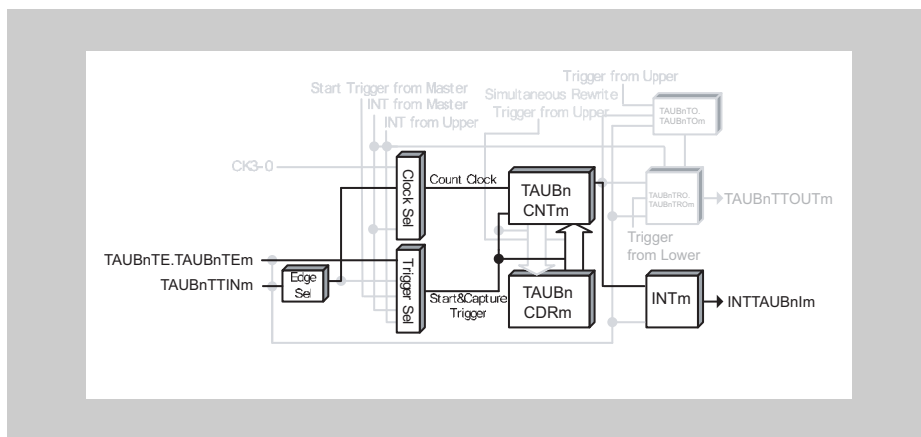

Figure 13-49 Block Diagram for External Event Count Function

The following settings apply to the general timing diagram.

- Rising edge detection (TAUBnCMURm.TAUBnTIS[1:0]=01B)

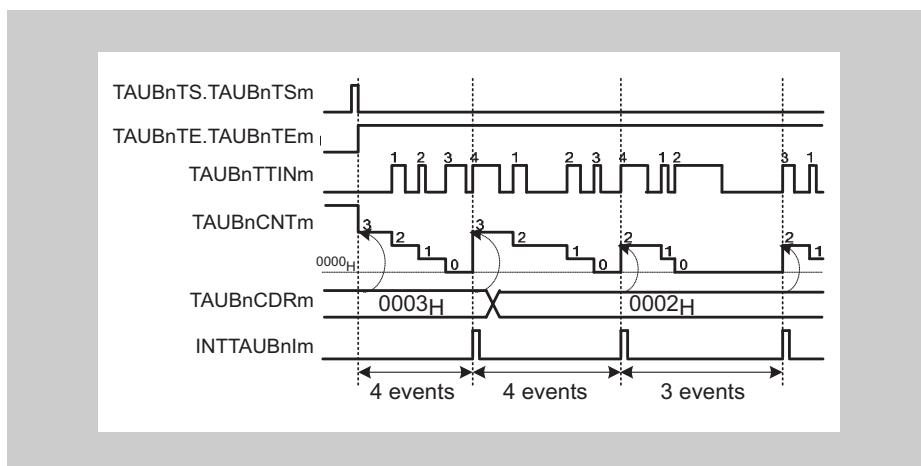

Figure 13-50 General Timing Diagram for External Event Count Function

(4) Register settings

(a) TAUBnCMORm

15	14	13	12	11	10	9	8	7	6	5	4	3	2	1	0
TAUBnCKS [1:0]	TAUBnCCS [1:0]	TAUBnMAS	TAUBnSTS [2:0]	TAUBnCOS [1:0]	-	TAUBnMD [4:1]				TAUBnMD0					

Table 13-54 TAUBnCMORm Settings for External Event Count Function

Bit Name	Setting
TAUBnCKS[1:0]	00: Operation clock = CK0 01: Operation clock = CK1 10: Operation clock = CK2 11: Operation clock = CK3
TAUBnCCS[1:0]	01: Valid TAUBnTTINm input edge is used as the count clock
TAUBnMAS	0: Unused. Set to 0.
TAUBnSTS[2:0]	000: Triggers the counter by software.
TAUBnCOS[1:0]	00: Unused. Set to 00.
TAUBnMD[4:1]	0011: Event count mode
TAUBnMD0	0: INTTAUBnIm not generated at operation start

(b) TAUBnCMURm

7	6	5	4	3	2	1	0
—	—	—	—	—	—	TAUBnTIS[1:0]	

Table 13-55 TAUBnCMURm Settings for External Event Count Function

Bit Name	Setting
TAUBnTIS[1:0]	00: Falling edge 01: Rising edge 10: Rising and falling edge

(c) Channel output mode

The channel output mode is not used by this function. However, it can be used in independent channel output mode controlled by software.

(d) Simultaneous rewrite

The simultaneous rewrite registers (TAUBnRDE, TAUBnRDS, TAUBnRDM, and TAUBnRDC) cannot be used with the external event count function. Therefore, these registers should be set to 0.

Table 13-56 Simultaneous Rewrite Settings for External Event Count Function

Bit Name	Setting
TAUBnRDE.TAUBnRDEm	0: Disables simultaneous rewrite.
TAUBnRDS.TAUBnRDSm	0: When disabling simultaneous rewrite (TAUBnRDE.TAUBnRDEm = 0), set these bits to 0.
TAUBnRDM.TAUBnRDMm	
TAUBnRDC.TAUBnRDCm	

(5) Operating procedure for external event count function

Table 13-57 Operating Procedure for External Event Count Function

	Operation	Status of TAUBn
Restart ↑	Initial channel setting Set the TAUBnCMORm register and TAUBnCMURm registers as described in Table 13-54, TAUBnCMORm Settings for External Event Count Function and Table 13-55, TAUBnCMURm Settings for External Event Count Function. Set the value of the TAUBnCDRm register	Channel operation is stopped.
	Start operation Set TAUBnTS.TAUBnTSM to 1. TAUBnTS.TAUBnTSM is a trigger bit, so it is automatically cleared to 0.	TAUBnTE.TAUBnTEM is set to 1 and the counter starts. TAUBnCNTm loads the TAUBnCDRm value and waits for detection of the TAUBnTTINm input edge.
	During operation Detection of TAUBnTTINm edges. The value of TAUBnCDRm can be changed at any time. The TAUBnCNTm register can be read at any time.	TAUBnCNTm performs count-down operation each time a TAUBnTTINm input edge is detected. When the counter reaches 0000 _H : <ul style="list-style-type: none"> • TAUBnCNTm reloads the TAUBnCDRm value and continues count operation • INTTAUBnIm is generated. Afterwards, this procedure is repeated.
	Stop operation Set TAUBnTT.TAUBnTTM to 1. TAUBnTT.TAUBnTTM is a trigger bit, so it is automatically cleared to 0.	TAUBnTE.TAUBnTEM is cleared to 0 and the counter stops. TAUBnCNTm stops and retains its current value.

(6) Specific timing diagrams

(a) TAUBnCDRm = 0000_H

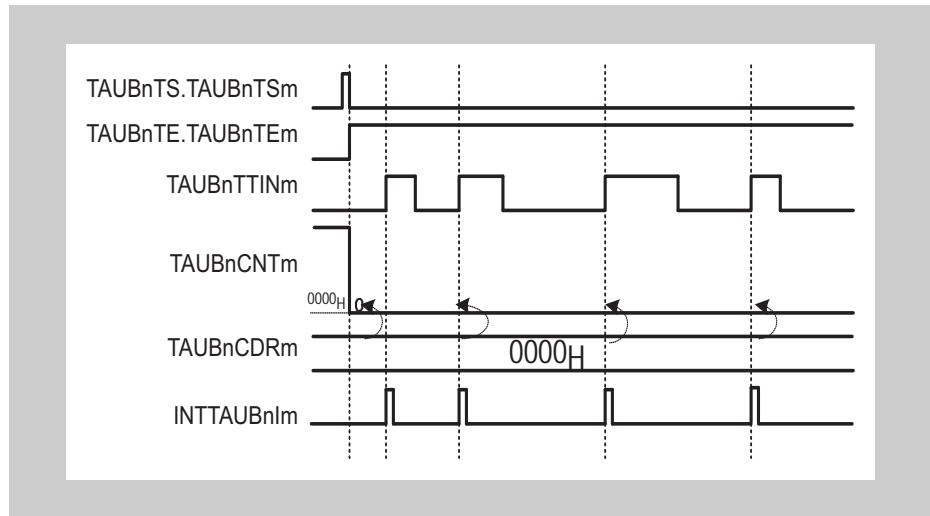

Figure 13-51 TAUBnCDRm = 0000_H, TAUBnCMURm.TAUBnTIS[1:0] = 01_B

- If 0000_H = TAUBnCDRm, 0000_H is loaded into TAUBnCNTm every time a valid TAUBnTTINm input edge is detected.

This means, INTTAUBnIm is generated every time a valid TAUBnTTINm input edge is detected.

(b) Operation stop and restart

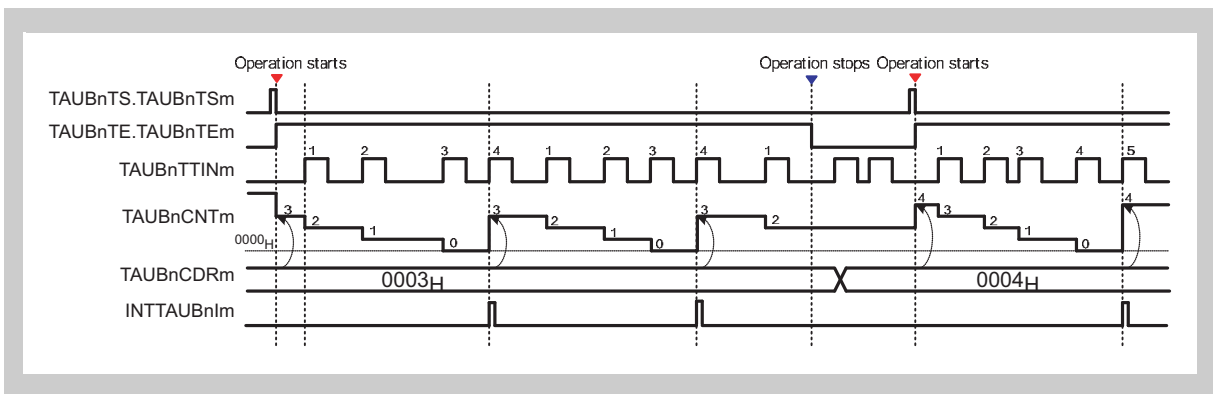

Figure 13-52 Operation Stop and Restart, TAUBnCMURm.TIS[1:0] = 01_B

- The counter can be stopped by setting TAUBnTT.TAUBnTTm to 1, which in turn sets TAUBnTE.TAUBnTEm to 0.
- TAUBnCNTm stops and the current value is retained. TAUBnTTINm continues and TAUBnCNTm ignores the valid edge.
- The counter can be restarted by setting TAUBnTS.TAUBnTSm to 1. TAUBnCNTm loads the TAUBnCDRm value and restarts count operation.

(c) Forced restart

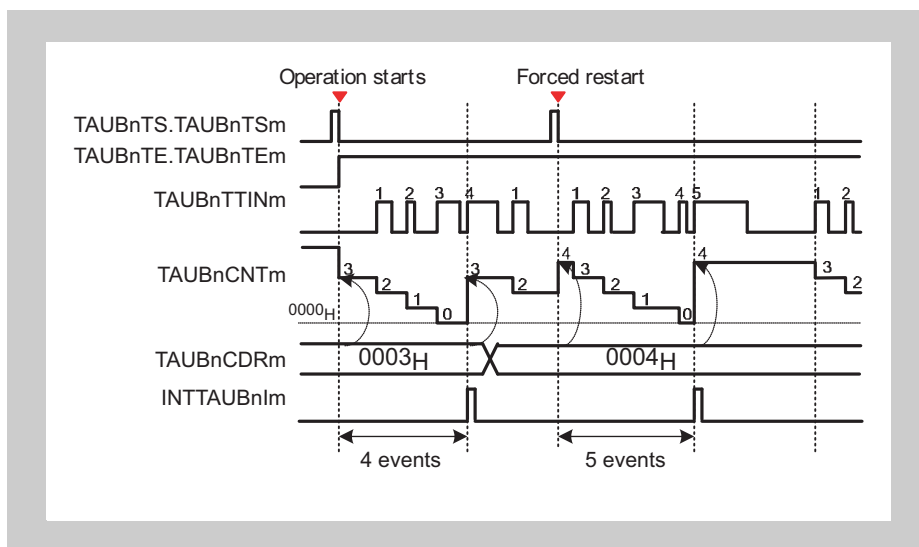

Figure 13-53 Forced Restart, TAUBnCMURm.TAUBnTIS[1:0] = 01_B

A forced restart applies a change to TAUBnCDRm immediately.

- The counter can be restarted (without stopping it first), by setting TAUBnTS.TAUBnTSM to 1 during operation.
- The value of TAUBnCDRm is loaded into TAUBnCNTm and the counter awaits the next valid TAUBnTTINm input edge.

13.16.2 Clock Divide Function

(1) Overview

Summary This function is used as a frequency divider. The frequency of the input signal TAUBnTTINm is divided by a factor related to TAUBnCDRm, and the resulting signal is output to TAUBnTTOUTm.

- Prerequisites**
- TAUBnTTINm must have a fixed frequency.
 - The operation mode must be set to interval timer mode. (Refer to Table 13-58, TAUBnCMORm Settings for Clock Divide Function.)
 - The channel output mode must be set to independent channel output mode 1. Refer to Section 13.8, Channel Output Modes.

Description The counter is started by setting the channel trigger bit (TAUBnTS.TAUBnTSM) to 1. This in turn sets TAUBnTE.TAUBnTEM = 1, enabling count operation. The current value of TAUBnCDRm is loaded into TAUBnCNTm and the counter starts to count down from this value, using TAUBnTTINm as the count clock.

When the counter value reaches 0000_H, INTTAUBnIm is generated and the TAUBnTTOUTm signal toggles. TAUBnCNTm then loads the TAUBnCDRm value and subsequently continues operation.

The value of TAUBnCDRm can be rewritten at any time, and the changed value of TAUBnCDRm is applied the next time the function starts to count down.

The counter can be stopped by setting TAUBnTT.TAUBnTTM = 1, which in turn sets TAUBnTE.TAUBnTEM = 0. TAUBnCNTm and TAUBnTTOUTm stop but retain their values. The function can be restarted by setting TAUBnTS.TAUBnTSM = 1. The counter can also be forcibly restarted (without stopping it first) by setting TAUBnTS.TAUBnTSM = 1 during operation.

Conditions If the TAUBnCMORm.TAUBnMD0 bit is set to 0, the first interrupt after a start or restart is not generated, and therefore TAUBnTTOUTm does not toggle. This results in an inverted TAUBnTTOUTm signal compared to when TAUBnCMORm.TAUBnMD0 is set to 1. For details refer to Section 13.10, TAUBnTTOUTm Output and INTTAUBnIm Generation when Counter Starts or Restarts (TAUBnMD0 bit).

Note TAUBnTTINm input signal is sampled at the frequency of a sampling clock set by the TAUBnCMORm.TAUBnCKS[1:0] bits. As a result, the output cycle of TAUBnTTOUTm has an error of ± 1 operation clock cycle.

(2) Equations

- When rising edge detection is selected:

$$\text{TAUBnTTOUTm frequency} = \text{TAUBnTTINm frequency} / [(\text{TAUBnCDRm} + 1) \times 2]$$
- When falling edge detection is selected:

$$\text{TAUBnTTOUTm frequency} = \text{TAUBnTTINm frequency} / [(\text{TAUBnCDRm} + 1) \times 2]$$
- When rising and falling edge detection is selected:

$$\text{TAUBnTTOUTm frequency} = \text{TAUBnTTINm frequency} / (\text{TAUBnCDRm} + 1)$$

(3)Block diagram and general timing diagram

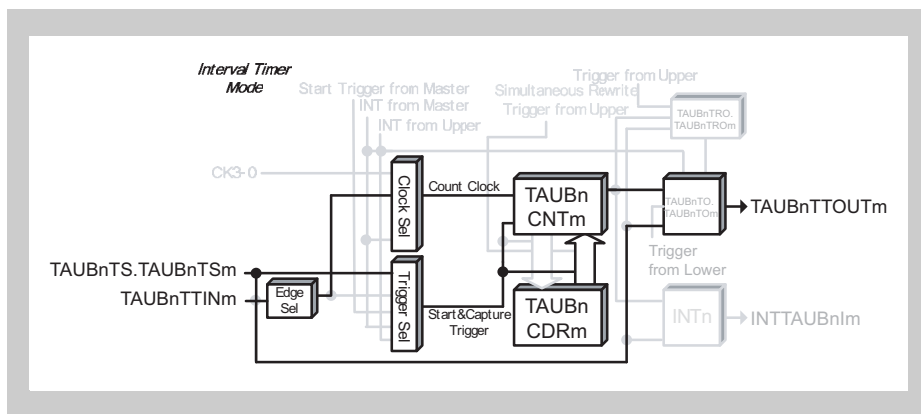

Figure 13-54 Block Diagram for Clock Divide Function

The following settings apply to the general timing diagram:

- INTTAUBnIm generated at operation start (TAUBnCMORm.TAUBnMD0 = 1)
- Rising edge detection (TAUBnCMURm.TAUBnTIS[1:0] = 01_B)

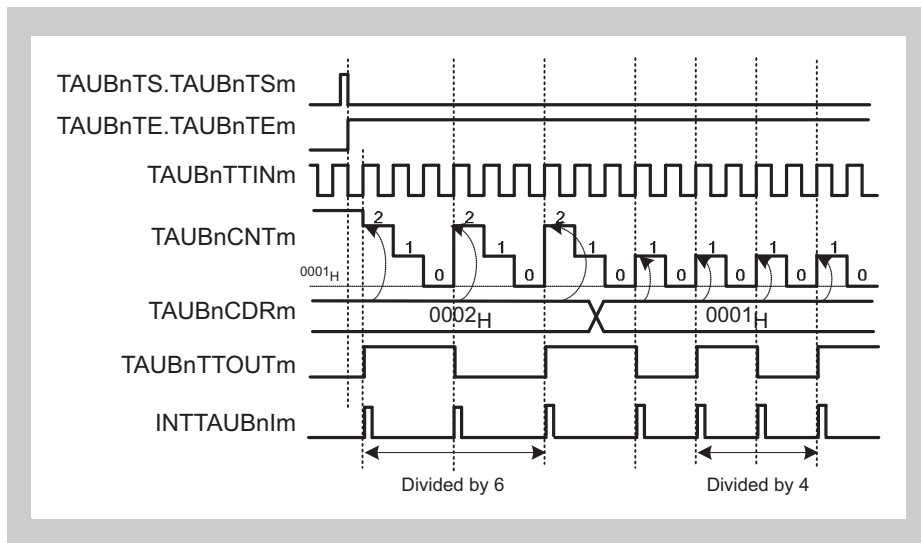

Figure 13-55 General Timing Diagram for Clock Divide Function

(4) Register settings**(a) TAUBnCMORm**

15	14	13	12	11	10	9	8	7	6	5	4	3	2	1	0
TAUBnCKS [1:0]	TAUBnCCS [1:0]	TAUB nMAS	TAUBnSTS [2:0]	TAUBnCOS [1:0]	-	TAUBnMD [4:1]				TAUB nMD0					

Table 13-58 TAUBnCMORm Settings for Clock Divide Function

Bit Name	Setting
TAUBnCKS[1:0]	00: Operation clock = CK0 01: Operation clock = CK1 10: Operation clock = CK2 11: Operation clock = CK3
TAUBnCCS[1:0]	1: Valid TAUBnTTINm input edge is used as the count clock.
TAUBnMAS	0: Unused. Set to 0.
TAUBnSTS[2:0]	000: Triggers the counter by software.
TAUBnCOS[1:0]	00: Unused. Set to 00.
TAUBnMD[4:1]	0000: Interval timer mode
TAUBnMD0	0: INTTAUBnIm is not generated and TAUBnTTOUTm is not toggled at the beginning of operation. 1: INTTAUBnIm is generated and TAUBnTTOUTm is toggled at the beginning of operation.

(b) TAUBnCMURm

7	6	5	4	3	2	1	0
—	—	—	—	—	—	TAUBnTIS[1:0]	

Table 13-59 TAUBnCMURm Settings for Clock Divide Function

Bit Name	Setting
TAUBnTIS[1:0]	00: Falling edge detection 01: Rising edge detection 10: Rising and falling edge detection

(c) Channel output mode**Table 13-60 Control Bit Settings for Independent Channel Output Mode 1**

Bit Name	Setting
TAUBnTOE.TAUBnTOEm	1: Enables independent channel output mode controlled by software.
TAUBnTOM.TAUBnTOMm	0: Independent channel output
TAUBnTOC.TAUBnTOCm	0: Operation mode 1 (Toggle mode if TAUBnTOM.TAUBnTOMm = 0)
TAUBnTOL.TAUBnTOLm	0: Positive logic
TAUBnTDE.TAUBnTDEm	0: Disables dead time operation.
TAUBnTDL.TAUBnTDLm	0: When dead time operation is disabled (TAUBnTDE.TAUBnTDEm = 0), set these bits to 0.

Note The channel output mode can also be set to channel output mode controlled by software by setting TAUBnTOE.TAUBnTOEm = 0. TAUBnTTOUm can then be controlled independently of the interrupts. For details refer to Table 13-10, Channel Output Modes.

(d) Simultaneous rewrite

The simultaneous rewrite registers (TAUBnRDE, TAUBnRDS, TAUBnRDM, and TAUBnRDC) cannot be used with the clock divide function. Therefore, these registers must be set to 0.

Table 13-61 Simultaneous Rewrite Settings for Clock Divide Function

Bit Name	Setting
TAUBnRDE.TAUBnRDEm	0: Disables simultaneous rewrite.
TAUBnRDS.TAUBnRDSm	0: When simultaneous rewrite is disabled (TAUBnRDE.TAUBnRDEm = 0), set these bits to 0.
TAUBnRDM.TAUBnRDMm	
TAUBnRDC.TAUBnRDCm	

(5)Operating procedure for clock divide function

Table 13-62 Operating Procedure for Clock Divide Function

	Operation	Status of TAUBn
Restart	Initial channel setting Set the value of the TAUBnCDRm register. Set the channel output mode by setting the control bits as described in Table 13-60, Control Bit Settings for Independent Channel Output Mode 1.	Channel operation is stopped.
	Start operation Set TAUBnTS.TAUBnTSm to 1. TAUBnTS.TAUBnTSm is a trigger bit, so it is automatically cleared to 0.	TAUBnTE.TAUBnTEm is set to 1 and the counter starts. TAUBnCNTm loads TAUBnCDRm value. If TAUBnCMORm.TAUBnMD0 is set to 1, INTTAUBnIm occurs and TAUBnTTOUTm is toggled.
	During operation The value of TAUBnCDRm can be changed at any time. The TAUBnCNTm register can be read at all times.	When a TAUBnTTINm input edge is detected, TAUBnCNTm counts down. When the counter reaches 0000 _H : <ul style="list-style-type: none"> • AUBnCDRm value is loaded into TAUBnCNTm and count operation continues. • INTTAUBnIm is generated. • TAUBnTTOUTm is toggled. Afterwards, this procedure is repeated.
	Stop operation Set TAUBnTT.TAUBnTTm to 1. TAUBnTT.TAUBnTTm is a trigger bit, so it is automatically cleared to 0.	TAUBnTE.TAUBnTEm is cleared to 0 and the counter stops. TAUBnCNTm stops and TAUBnCNTm and TAUBnTTOUTm retain their current values.

(6) Specific timing diagrams

(a) TAUBnCDRm = 0000_H

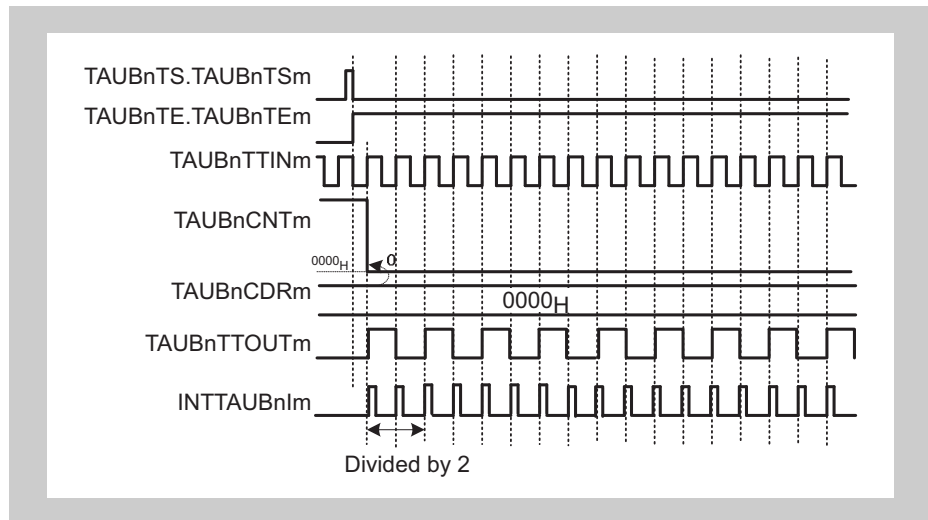

Figure 13-56 TAUBnCDRm = 0000_H, TAUBnCMORm.TAUBnMD0 = 1, TAUBnCMURm.TAUBnTIS[1:0] = 01_B

- If TAUBnCDRm is 0000_H, TAUBnCNTm is also always 0000_H.
- INTTAUBnIm is generated every count clock, resulting in TAUBnTTOUTm toggling every count clock.

Figure 13-56 shows an operation timing example. Actually, there is a delay from TINm detection until TOUTm output because of the delay time of a noise filter or synchronization circuit placed between the TAUBnIm pin and TAUBn.

(b) Restart

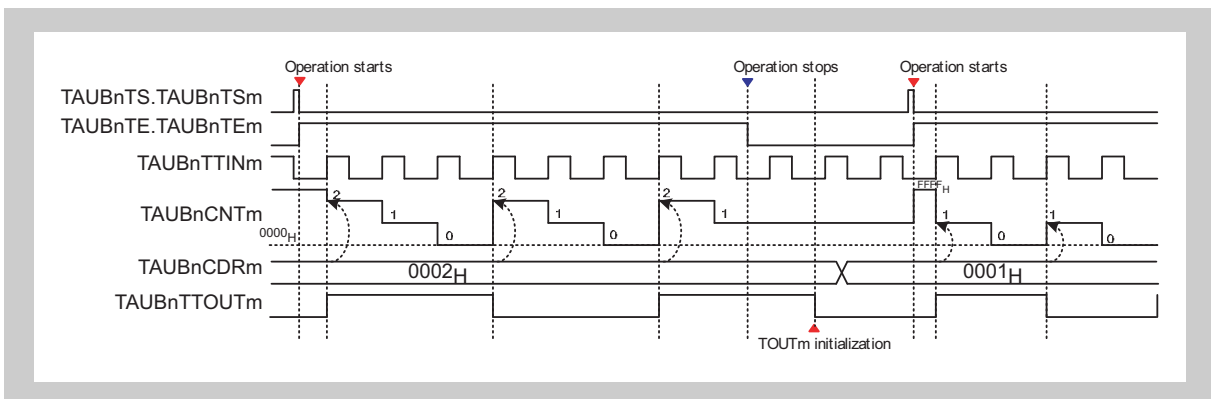

Figure 13-57 Restart, TAUBnCMORm.TAUBnMD0 = 1, TAUBnCMURm.TAUBnTIS[1:0] = 01_B

To reset the value of TAUBnTTOUTm:

- Set TAUBnTOE.TAUBnTOEm = 0 when the counter is stopped (TAUBnTE.TAUBnTEm = 0)
- Then write either 0 or 1 to TAUBnTO.TAUBnTOm to set the new start value of TAUBnTTOUTm

(c) Forced restart

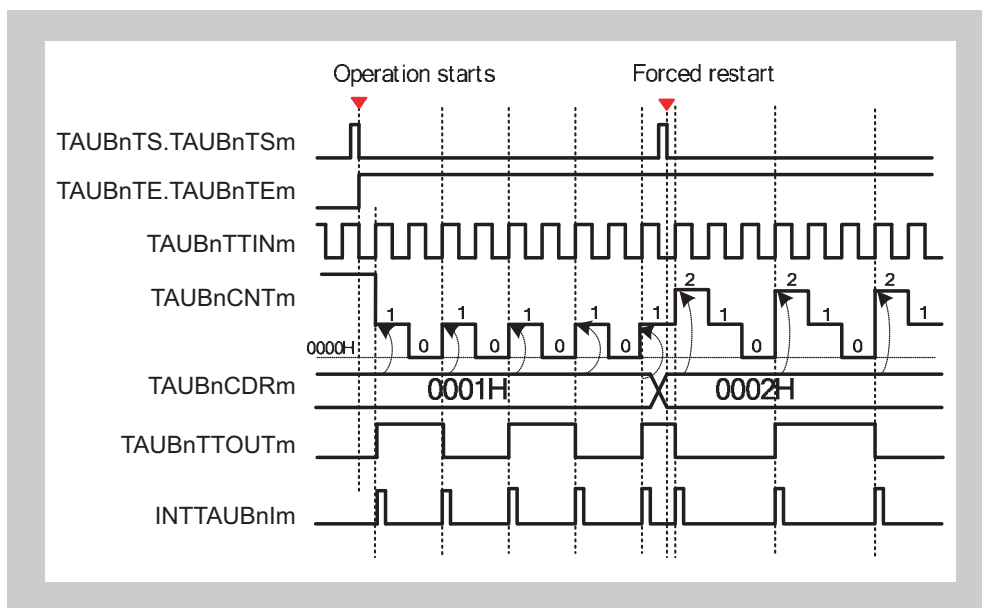

Figure 13-58 Forced restart, TAUBnCMORm.TAUBnMD0 = 1, TAUBnCMURm.TAUBnTIS[1:0] = 01_B

To reset the value of TAUBnTTOUTm:

- The counter can be forcibly restarted (without stopping it first) by setting TAUBnTS.TAUBnTSTm = 1 during operation.
- The value of TAUBnCDRm is written to TAUBnCNTm and the count operation restarts.
- TAUBnTTOUTm restarts at the same level as before the forced restart.

13.16.3 TAUBnTTINm Input Position Detection Function

(1) Overview

- Summary** This function measures the duration between the function start and a TAUBnTTINm input signal.
- Prerequisites**
- The operation mode must be set to count capture mode. Refer to Table 13-63, TAUBnCMORm Settings for TAUBnTTINm Input Position Detection Function.
 - TAUBnTTOUTm is not used for this function.
- Description** The counter is enabled by setting the channel trigger bit (TAUBnTS.TAUBnTSM) to 1. This in turn sets TAUBnTE.TAUBnTEM = 1, enabling count operation. The counter starts to count from 0000_H. When a valid TAUBnTTINm input edge is detected, the current TAUBnCNTm value is loaded into TAUBnCDRm and an interrupt (INTTAUBnIm) is generated. The counter continues to count.
- When the counter reaches FFFF_H, the counter restarts from 0000_H.
- Note** TAUBnTTINm input signal is sampled at the frequency of a sampling clock set by the TAUBnCMORm.TAUBnCKS[1:0] bits. As a result, the output cycle of TAUBnTTOUTm has an error of ± 1 operation clock cycle.
- Conditions** If the TAUBnCMORm.TAUBnMD0 bit is set to 0, the first interrupt after a start or restart is not generated. For details refer to Section 13.10, TAUBnTTOUTm Output and INTTAUBnIm Generation when Counter Starts or Restarts (TAUBnMD0 bit).

(2) Equations

Function duration at a TAUBnTTINm input pulse =
 count clock cycle \times (TAUBnCDRm capture value + 1)

(3) Block diagram and general timing diagram

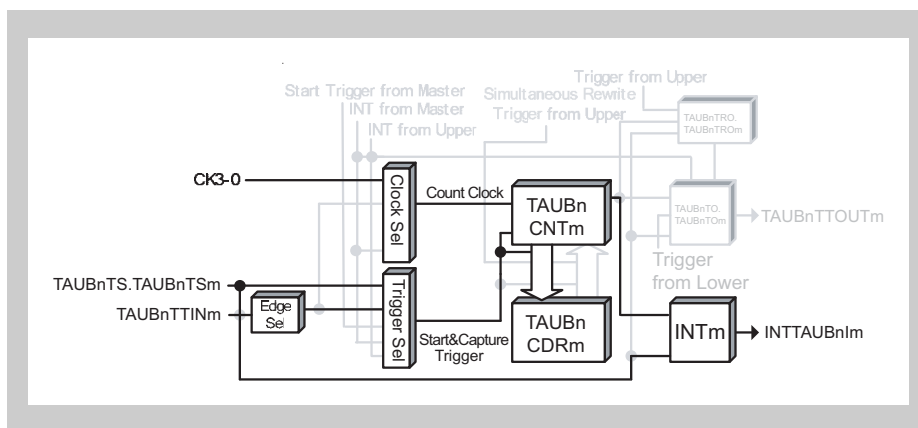

Figure 13-59 Block Diagram for TAUBnTTINm Input Position Detection Function

The following settings apply to the general timing diagram:

- INTTAUBnIm not generated at operation start (TAUBnCMORm.TAUBnMD0 = 0)
- Falling edge detection (TAUBnCMURm.TAUBnTIS[1:0] = 00B)

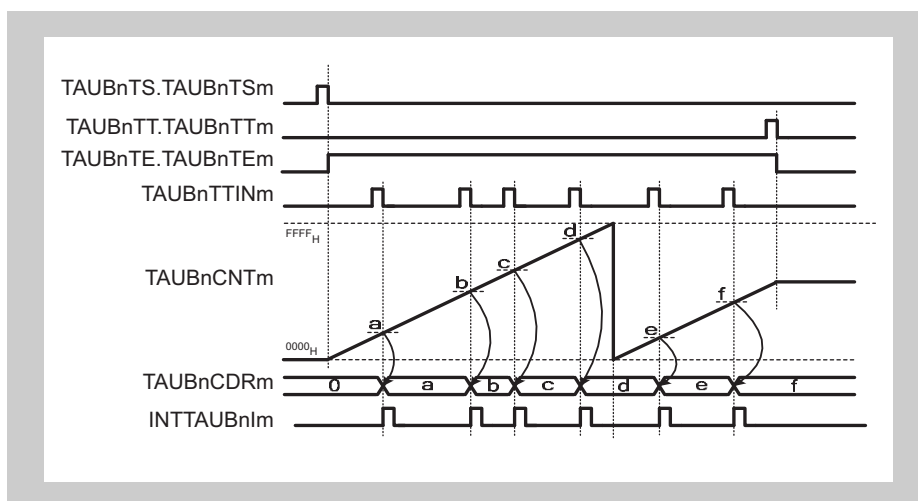

Figure 13-60 General Timing Diagram for TAUBnTTINm Input Position Detection Function

(4) Register settings

(a) TAUBnCMORm

15	14	13	12	11	10	9	8	7	6	5	4	3	2	1	0
TAUBnCKS [1:0]		TAUBnCCS [1:0]		TAUBnMAS	TAUBnSTS [2:0]		TAUBnCOS [1:0]		-	TAUBnMD [4:1]				TAUBnMDO	

Table 13-63 TAUBnCMORm Settings for TAUBnTTINm Input Position Detection Function

Bit Name	Setting
TAUBnCKS[1:0]	00: Operation clock = CK0 01: Operation clock = CK1 10: Operation clock = CK2 11: Operation clock = CK3
TAUBnCCS[1:0]	0: Uses an operation clock as the count clock.
TAUBnMAS	0: Unused. Set to 0.
TAUBnSTS[2:0]	001: Valid TAUBnTTINm input edge signal is used as the external capture trigger.
TAUBnCOS[1:0]	01: Set this value.
TAUBnMD[4:1]	1011: Count capture mode
TAUBnMDO	0: INTTAUBnIm is not generated at operation start. 1: INTTAUBnIm is generated at operation start.

(b) TAUBnCMURm

7	6	5	4	3	2	1	0
—	—	—	—	—	—	TAUBnTIS[1:0]	

Table 13-64 TAUBnCMURm Settings for TAUBnTTINm Input Position Detection Function

Bit Name	Setting
TAUBnTIS[1:0]	00: Falling edge detection 01: Rising edge detection 10: Rising and falling edge detection

(c) Channel output mode

Channel output mode is not used by this function. However, it can be used in independent channel output mode controlled by software.

(d) Simultaneous rewrite

The simultaneous rewrite registers (TAUBnRDE, TAUBnRDS, TAUBnRDM, and TAUBnRDC) cannot be used with the TAUBnTTINm input position detection function. Therefore, these registers should be set to 0.

Table 13-65 Simultaneous Rewrite Settings for TAUBnTTINm Input Position Detection Function

Bit name	Setting
TAUBnRDE.TAUBnRDEm	0: Disables simultaneous rewrite.
TAUBnRDS.TAUBnRDSm	0: When simultaneous rewrite is disabled (TAUBnRDE.TAUBnRDEm = 0), set these bits to 0.
TAUBnRDM.TAUBnRDMm	
TAUBnRDC.TAUBnRDCm	

(5) Operating procedure for TAUBnTTINm Input Position Detection Function

Table 13-66 Operating Procedure for TAUBnTTINm Input Position Detection Function

	Operation	Status of TAUBn
Restart	Initial channel setting Set the TAUBnCMORm register and TAUBnCMURm registers as described in Table 13-63, TAUBnCMORm Settings for TAUBnTTINm Input Position Detection Function and Table 13-64, TAUBnCMURm Settings for TAUBnTTINm Input Position Detection Function. TAUBnCDRm register operates as a capture register.	Channel operation is stopped.
	Start operation Set TAUBnTS.TAUBnTSM to 1. TAUBnTS.TAUBnTSM is a trigger bit, so it is automatically cleared to 0.	TAUBnTE.TAUBnTEM is set to 1 and the counter starts. INTTAUBnIm is generated when TAUBnCMORm.TAUBnMD0 is set to 1.
	During operation The TAUBnCMURm.TAUBnTIS[1:0] bits can be changed at any time. The TAUBnCDRm and TAUBnCSRm registers can be read at any time.	TAUBnCNTm starts to count up from 0000 _H . When a TAUBnTTINm valid edge is detected: <ul style="list-style-type: none"> • TAUBnCNTm transfers (captures) its value to TAUBnCDRm. • TAUBnTTINm is output. • The counter value is not cleared to 0000_H and TAUBnCNTm continues count operation. Afterwards, this procedure is repeated.
	Stop operation Set TAUBnTT.TAUBnTTM to 1. TAUBnTT.TAUBnTTM is a trigger bit, so it is automatically cleared to 0.	TAUBnTE.TAUBnTEM is cleared to 0 and the counter stops. TAUBnCNTm stops and TAUBnCNTm remains its current value.

(6) Specific timing diagrams

(a) Operation Stop and Restart

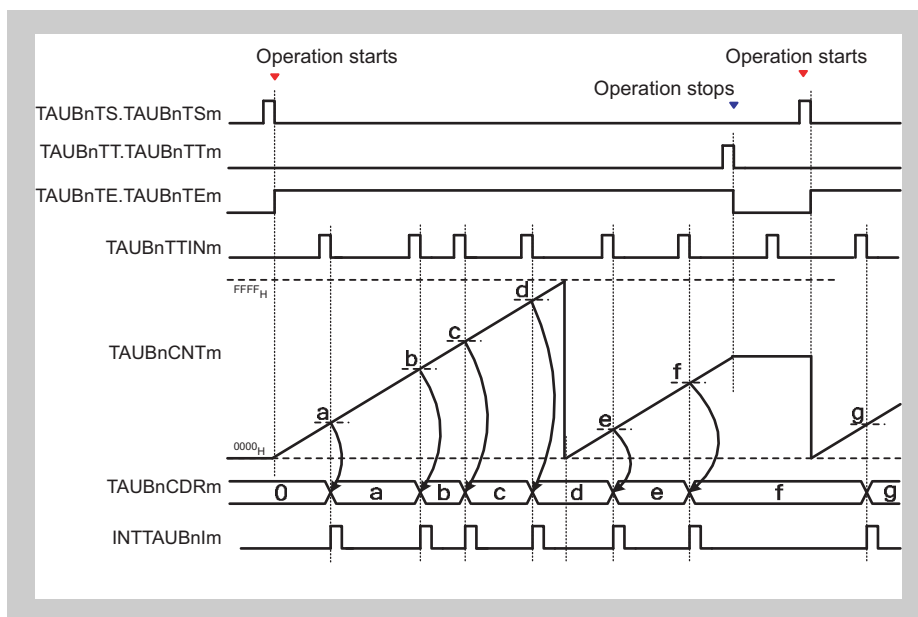

Figure 13-61 Operation Stop and Restart, TAUBnCMORM.TAUBnMD0 = 0, TAUBnCMURm.TAUBnTIS[1:0] = 00B

- The counter can be stopped by setting TAUBnTT.TAUBnTTM to 1, which in turn sets TAUBnTE.TAUBnTEM to 0.
- TAUBnCNTm stops and the current value is retained.
- If the counter is stopped, valid TAUBnTTINm input edges are ignored.
- The counter can be restarted by setting TAUBnTS.TAUBnTSM to 1. TAUBnCNTm restarts to count from 0000H.

13.17 Synchronous Channel Operation Functions

This section lists all the synchronous channel operation functions provided by the timer array unit A. For a general overview of synchronous channel operation, see Section 13.3, Functional Description.

13.18 Synchronous PWM Signal Functions Triggered at Regular Intervals

This section describes functions that generate PWM signals at regular intervals.

- Section 13.18.1, PWM Output Function
- Section 13.18.2, Delay Pulse Output Function
- Section 13.18.3, AD Conversion Trigger Output Function Type 1

13.18.1 PWM Output Function

(1) Overview

- Summary** This function generates multiple PWM outputs by using a master and multiple slave channels. It enables the pulse cycle (frequency) and the duty cycle of the TAUBnTTOUTm to be set. The pulse cycle is set in the master channel. The duty cycle is set in the slave channel.
- Prerequisites**
- Two channels
 - The operating mode for the master channel should be set to interval timer mode. (See Table 13-67, TAUBnCMORm Settings for Master Channels of PWM Output Function.)
 - The operating mode for the slave channels should be set to one count mode. (See Table 13-70, TAUBnCMORm Settings for Slave Channels of PWM Output Function.)
 - TAUBnTTOUTm is not used with the master channel of this function.
 - The channel output mode for the slave channels should be set to Synchronous Channel Output Mode 1. (See Section 13.8, Channel Output Modes.)
- Description** The counter is enabled by setting the channel trigger bit (TAUBnTS.TAUBnTSm) to 1. This sets TAUBnTE.TAUBnTEm = 1, enabling count operation. The current value of TAUBnCDRm is loaded into TAUBmCNT, and the counter starts counting down from the TAUBnCDRm value. If an INTTAUBnIm occurs on the master channel and TAUBnTTOUTm (slave) is set/reset, PWM output is made.
- Master channel:

When the master channel counter reaches 0000_H and the pulse cycle time has passed, INTTAUBnIm occurs. The counter loads TAUBnCDRm value into TAUBnCNTm and counts down.
 - Slave channels:

When INTTAUBnIm occurs on the master channel, the counter operation of the slave channel is triggered. The current value of TAUBnCDRm (slave) is loaded into TAUBnCNTm (slave) and the counter starts counting down from the TAUBnCDRm value. TAUBnTTOUTm signal is set to the active level.

When the counter reaches to 0000_H (duty time has elapsed), INTTAUBnIm occurs and a TAUBnTTOUTm signal is set to an inactive level. The counter is reset to FFFF_H and waits for the next INTTAUBnIm (start of the next pulse cycle) of the master channel.

The counter can stop operating by setting the TAUBnTT.TAUBnTTm of master and slave channels to 1. This sets TAUBnTE.TAUBnTEm to 0. TAUBnCNTm and TAUBnTTOUTm of master and slave channels stop but their values are retained. The counter can be restarted by setting TAUBnTS.TAUBnTSm to 1.
- Note** If a forced restart is executed during operation, the counter value becomes invalid and the PWM output wave from TAUBnTTOUTm does not output correct wave as PWM signal.
- Conditions** Simultaneous rewrite can be used with this function. See Section 13.7, Simultaneous Rewrite.

(2) Equations

Pulse cycle = (TAUBnCDRm (master) + 1) × count clock cycle

Duty cycle [%] = (TAUBnCDRm (slave) / (TAUBnCDRm (master) + 1) × 100

– Duty cycle = 0%

TAUBnCDRm (slave) = 0000_H

– Duty cycle = 100%

TAUBnCDRm (slave) ≥ TAUBnCDRm (master) + 1

(3) Block diagram and general timing diagram

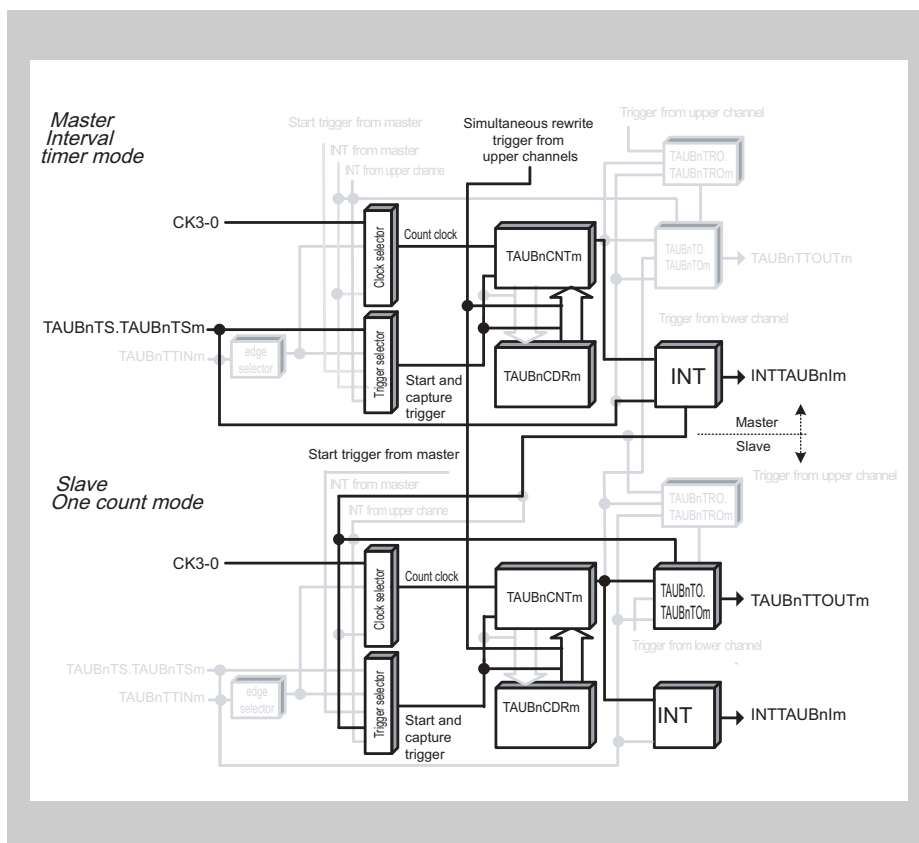

Figure 13-62 Block Diagram of PWM Output Function

The following settings apply to the general timing diagram.

- Slave channels: Positive logic (TAUBnTOL.TAUBnTOLm = 0)

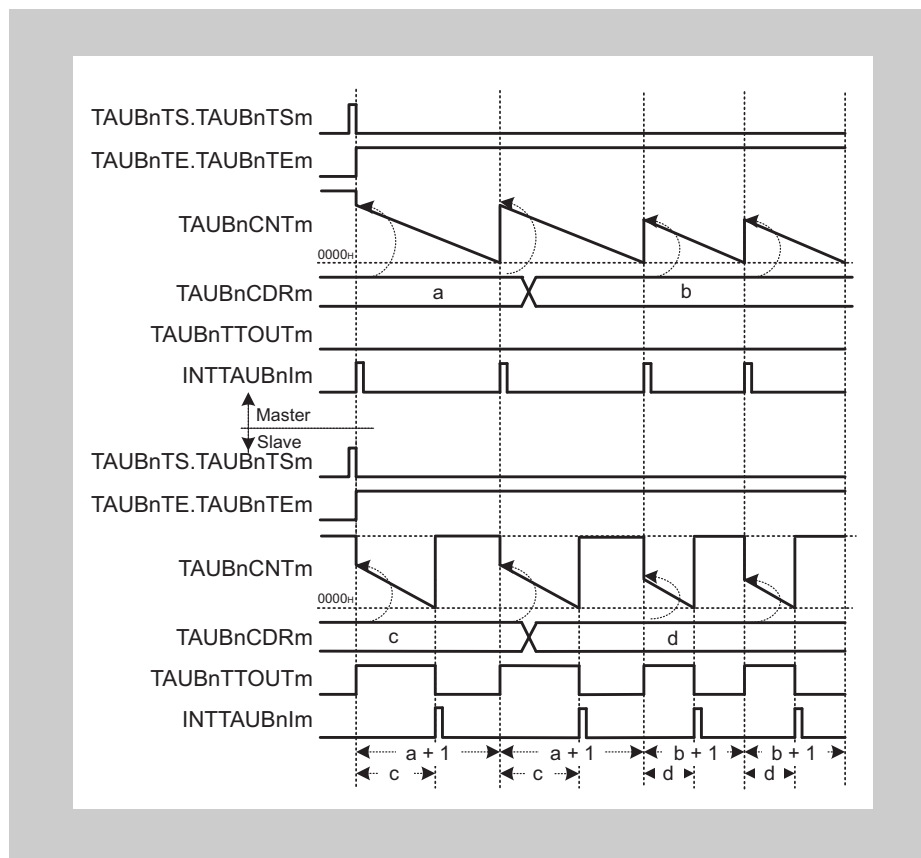

Figure 13-63 General Timing Diagram of PWM Output Function

Note The interval between the slave channel starting to count and an interrupt being generated is the value of corresponding TAUBnCDRm, whereas for the master channel the interval is the value of the corresponding TAUBnCDRm + 1.

(4) Register settings for master channels

(a) TAUBnCMORm for master channels

15	14	13	12	11	10	9	8	7	6	5	4	3	2	1	0
TAUBnCKS [1:0]	TAUBnCCS [1:0]	TAUBnMAS	TAUBnSTS[2:0]			TAUBnCOS [1:0]		-	TAUBnMD[4:1]				TAUBnMD0		

Table 13-67 TAUBnCMORm Settings for Master Channels of PWM Output Function

Bit Name	Setting
TAUBnCKS[1:0]	00: Prescaler output CK0 01: Prescaler output CK1 10: Prescaler output CK2 11: Prescaler output CK3 TAUBnCKS[1:0] bits of master and slave channels should have the same value.
TAUBnCCS[1:0]	00: Uses an operation clock as a count clock.
TAUBnMAS	1: Master channel
TAUBnSTS[2:0]	000: Triggers the counter by software.
TAUBnCOS[1:0]	00: Unused. Set to 00.
TAUBnMD[4:1]	0000: Interval timer mode
TAUBnMD0	1: INTTAUBnIm is generated at the beginning of operation.

(b) TAUBnCMURm for master channels

7	6	5	4	3	2	1	0
-						TAUBnTIS[1:0]	

Table 13-68 TAUBnCMURm Settings for Master Channels of PWM Output Function

Bit Name	Setting
TAUBnTIS[1:0]	00: Unused. Set to 00.

(c) Channel output mode for master channels

The channel output mode is not used with this function. However, this mode can be used with another function or in independent channel output mode controlled by software.

(d) Simultaneous rewrite for master channels

Both master and slave channels should have the same simultaneous rewrite settings.

Table 13-69 Simultaneous Rewrite Settings for Master Channels of the PWM Output Function

Bit Name	Setting
TAUBnRDE.TAUBnRDEm	1: Enables simultaneous rewrite.
TAUBnRDS.TAUBnRDSm	0: Monitors master channel for simultaneous rewrite triggers. 1: Monitors upper channel other than the channel group for simultaneous rewrite triggers.
TAUBnRDM.TAUBnRDMm	0: Generates a simultaneous rewrite trigger signal when the master channel starts to count.
TAUBnRDC.TAUBnRDCm	0: Channel is not monitored for INTTAUBnIm signals used as simultaneous rewrite triggers. When TAUBnRDS.TAUBnRDSm = 0, the master channel is monitored for simultaneous rewrite triggers regardless of the value of this bit.

Note Use with TAUBnRDS.TAUBnRDSm bit = 1 requires an upper channel higher than the master channel that operates with the "simultaneous rewrite trigger output function type 1."

Conduct operation settings under the following conditions:

- Simultaneous rewrite trigger output function type 1 setting channel:
TAUBnRDCm = 1, TAUBnRDS = 1
TAUBnCDR settings for this channel are as follows:
= ((TAUBnCDR setting for the master channel targeted for simultaneous rewrite + 1) × interrupt count) - 1
- Master channels: TAUBnRDCm = 0, TAUBnRDS = 1
- Slave channels: TAUBnRDCm = 0, TAUBnRDS = 1

If TAUBnCDRm (slave) setting > TAUBnCDRm (master) setting + 1, 100% duty output should be provided through aggregation.

(5) Register settings for slave channels

(a) TAUBnCMORm for slave channels

15	14	13	12	11	10	9	8	7	6	5	4	3	2	1	0
TAUBnCKS [1:0]	TAUBnCCS [1:0]	TAUB nMAS	TAUBnSTS[2:0]		TAUBnCOS [1:0]		-	TAUBnMD[4:1]				TAUBn MD0			

Table 13-70 TAUBnCMORm Settings for Slave Channels of PWM Output Function

Bit Name	Setting
TAUBnCKS[1:0]	00: Prescaler output CK0 01: Prescaler output CK1 10: Prescaler output CK2 11: Prescaler output CK3 TAUBnCKS[1:0] bits of master and slave channels should have the same value.
TAUBnCCS[1:0]	00: Uses an operation clock as a count clock.
TAUBnMAS	0: Slave channel
TAUBnSTS[2:0]	100: INTTAUBnIm of master channel is a start trigger.
TAUBnCOS[1:0]	00: Unused. Set to 00.
TAUBnMD[4:1]	0100: One-count mode
TAUBnMD0	1: Start trigger during operation is valid.

(b) TAUBnCMURm for slave channels

7	6	5	4	3	2	1	0
-						TAUBnTIS[1:0]	

Table 13-71 TAUBnCMURm Settings for Slave Channels of PWM Output Function

Bit Name	Setting
TAUBnTIS[1:0]	00: Unused. Set to 00.

(c) Channel output mode for slave channels**Table 13-72 Control Bit Settings in Synchronous Channel Output Mode 1**

Bit Name	Setting
TAUBnTOE.TAUBnTOEm	1: Enables independent channel output mode.
TAUBnTOM.TAUBnTOMm	1: Synchronous channel operation
TAUBnTOC.TAUBnTOCm	0: Operating mode 1
TAUBnTOL.TAUBnTOLm	0: Positive logic 1: Inverted logic
TAUBnTDE.TAUBnTDEm	0: Disables dead time operation.
TAUBnTDL.TAUBnTDLm	0: When disabling dead time operation (TAUBnTDE.TAUBnTDEm = 0), set these bits to 0.

(d) Simultaneous rewrite for slave channels

The simultaneous rewrite settings of master and slave channels should be identical.

Table 13-73 Simultaneous Rewrite Settings for Slave Channels of PWM Output Function

Bit Name	Setting
TAUBnRDE.TAUBnRDEm	1: Enables simultaneous rewrite.
TAUBnRDS.TAUBnRDsm	0: Monitors master channel for simultaneous rewrite triggers. 1: Monitors upper channel other than the channel group for simultaneous rewrite triggers.
TAUBnRDM.TAUBnRDMm	0: Generates a simultaneous rewrite trigger signal when the master channel starts to count.
TAUBnRDC.TAUBnRDCm	0: Channel is not monitored for INTTAUBnIm signals used as simultaneous rewrite triggers. When TAUBnRDS.TAUBnRDsm = 0, the master channel is monitored for simultaneous rewrite triggers regardless of the value of this bit.

(6) Operating procedure for PWM output function

Table 13-74 Operating Procedure for PWM Output Function

	Operation	TAUBn Status	
Restart ↑	Initial Channel Setting	<p>Master channels: Set TAUBnCMORm/TAUBnCMURm register and the channel output mode as described in (4) Register settings for master channels.</p> <p>Slave channels: Set TAUBnCMORm/TAUBnCMURm register and the channel output mode as described in (5) Register settings for slave channels.</p> <p>Set the value of TAUBnCDRm register of every channel.</p>	Channel operation is stopped.
	Start Operation	<p>Set TAUBnTS.TAUBnTSm of master and slave channels to 1 simultaneously. TAUBnTS.TAUBnTSm is a trigger bit, which is automatically cleared to 0.</p>	TAUBnTE.TAUBnTEm (master and slave channels) is set to 1 and the counters of master and slave channels start. INTTAUBnIm is generated on the master channel and TAUBnTTOUTm (slave) is set.
	During Operation	<p>TAUBnCDRm can be changed at any time. TAUBnCNTm and TAUBnRSF.TAUBnRSFm can be read at any time.</p> <p>TAUBnRDT.TAUBnRDTm can be changed during operation.</p>	<p>TAUBnCNTm of master channel loads TAUBnCDRm value and counts down. When the counter reaches 0000_H:</p> <ul style="list-style-type: none"> • INTTAUBnIm (master) occurs. • TAUBnCDRm value is loaded into TAUBnCNTm (master) to continue count operation. • TAUBnCDRm value is loaded into TAUBnCNTm (slave) to perform counting down. • TAUBnTTOUTm (slave) is set to the active level. <p>If TAUBnCNTm (slave) reaches 0000_H:</p> <ul style="list-style-type: none"> • INTTAUBnIm (slave) occurs. • TAUBnTTOUTm (slave) is set to an inactive level.
	Stop Operation	<p>Set TAUBnTT.TAUBnTTm of master and slave channels to 1 simultaneously. TAUBnTT.TAUBnTTm is a trigger bit, which is automatically cleared to 0.</p>	<p>TAUBnTE.TAUBnTEm is cleared to 0 and the counter stops.</p> <p>TAUBnCNTm and TAUBnTTOUTm stop and retain their current values.</p>

(7) Specific timing diagrams

(a) Duty cycle = 0%

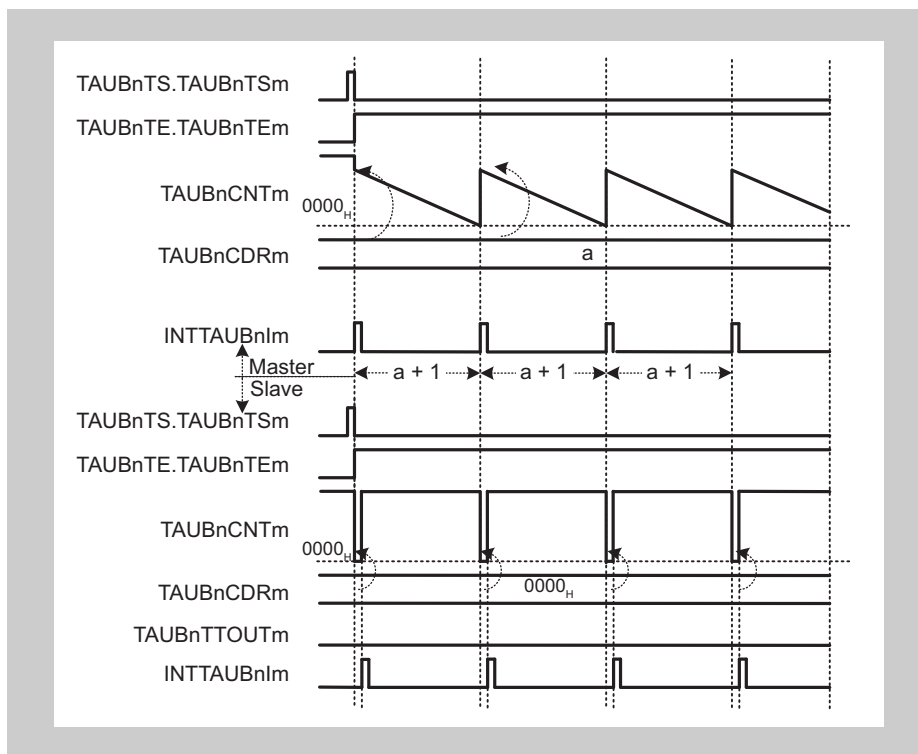

Figure 13-64 TAUBnCDRm (Slave) = 0000_H, Positive Logic (TAUBnTOL.TAUBnTOLm (Slave) = 0)

- Every time the master channel generates an interrupt (INTTAUBnIm), 0000_H is loaded in to TAUBnCNTm (slave). Therefore, TAUBnCNTm (slave) cannot start to count and TAUBnTTOUtm remains inactive.
- TAUBnCDRm value is loaded into TAUBnCNTm (slave) to generate an interrupt.

(b) Duty cycle = 100%

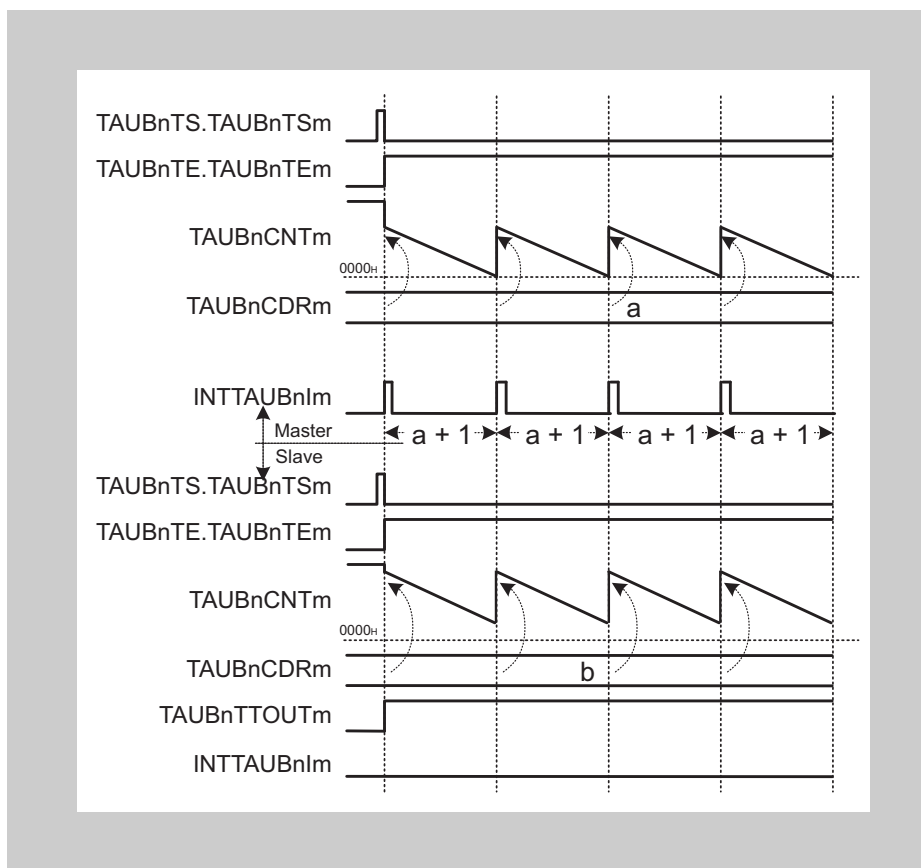

Figure 13-65 $TAUBnCDRm (Slave) \geq TAUBnCDRm (Master) + 1$
Positive Logic ($TAUBnTOL.TAUBnTOLm (Slave) = 0$)

- If TAUBnCDRm (slave) value is greater than TAUBnCDRm (master) value, the slave channel counter does not reach 0000_H and consequently, no interrupt occurs. TAUBnTTOUtm remains active.

(c) Operation stop and restart

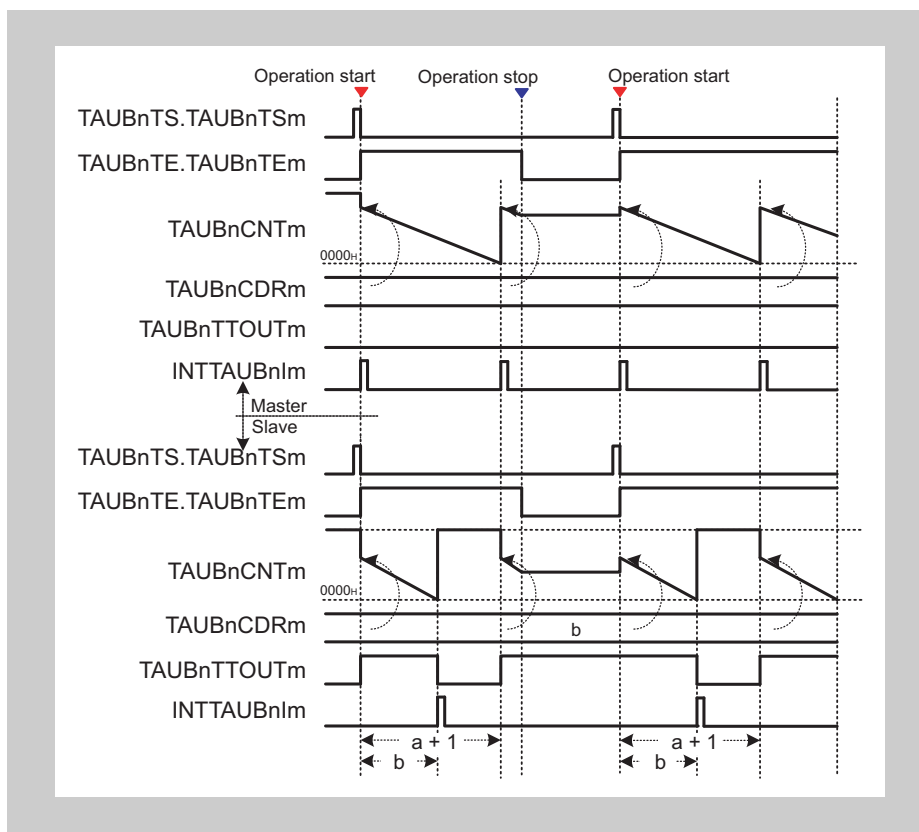

Figure 13-66 Operation Stop and Restart
Positive Logic (TAUBnTOL.TAUBnTOLm (Slave) = 0)

- The counter can be stopped by setting TAUBnTT.TAUBnTTm of master and slave channels to 1. This sets TAUBnTE.TAUBnTEm to 0.
- TAUBnCNTm and TAUBnTTOUm of all channels stop and the current values are retained. No interrupts are generated.
- The counter can be restarted by setting TAUBnTS.TAUBnTSm of master and slave channels to 1. TAUBnCNTm of master and slave channels reload the current values of TAUBnCDRm and start to count down from these values.

13.18.2 Delay Pulse Output Function

(1) Overview

Summary This function outputs two signals. The pulse width and pulse cycle of the reference signal are defined using the master channel and slave channel 1. Slave channels 2 and 3 output the reference signal with a specified delay. The delay signal is identical to the reference signal, but delayed by the amount specified on slave channel 2.

The signal values are specified in the following way:

- The pulse cycle is specified using the master channel.
- The duty cycle of the reference signal is specified using slave channel 1. The duty cycle of the delay signal is specified using slave channel 3.
- The delay is specified on slave channel 2.

Prerequisites

- Four channels
- The operating mode for the master channel should be set to interval timer mode. (See Table 13-75, TAUBnCMORm Settings for Master Channels of the Delay Pulse Output Function.)
- The operating mode for slave channels 1 and 2 should be set to one-count mode. (See Table 13-78, TAUBnCMORm Settings for Slave Channel 1 of Delay Pulse Output Function.)
- The operating mode for slave channel 3 should be set to pulse one-count mode. (See Table 13-82, TAUBnCMORm Settings for Slave Channel 2 of Delay Pulse Output Function.)
- TAUBnTTOUtm is not used with the master channel and slave channel 2.
- The channel output mode for slave channel 1 should be set to synchronous channel output mode 1. (See Section 13.8, Channel Output Modes.)
- The channel output mode for slave channel 3 should be set to independent channel output mode 2. (See Section 13.8, Channel Output Modes.)

Description The counters of the channel group are started by setting the channel trigger bit (TAUBnTS.TAUBnTsm) to 1. This sets TAUBnTE.TAUBnTEm to 1, enabling count operation.

- Master channel:

The current value of TAUBnCDRm is loaded into TAUBnCNTm and the counter starts to count down from this value. INTTAUBnIm is generated on the master channel.

When the counter value of master channel reaches 0000_H and pulse cycle time has elapsed, INTTAUBnIm is generated. The TAUBnCDRm value is reloaded into the counter to perform count down.

- Slave channels 1 and 2:

Slave channels 1 and 2 start to count down from the current TAUBnCDRm value when detecting an interrupt from the master channel. TAUBnTTOUtm signal (slave 1) is set.

- Slave channel 1:

When the counter of slave channel 1 reaches 0000_H (duty time has elapsed), INTTAUBnIm is generated and TAUBnTTOUtm signal is reset. The counter is reset to FFFF_H and waits for the next INTTAUBnIm of master channel.

- Slave channel 2:

When the counter of slave channel 2 reaches 0000_H and delay time has elapsed, INTTAUBnIm is generated. The counter is reset to $FFFF_H$ and waits for the next INTTAUBnIm of master channel.

Generating INTTAUBnIm (slave channel 2) triggers the counter of slave channel 3.

- Slave channel 3:

When slave channel 3 detects an interrupt from slave channel 2, its counter starts counting down from the current value of TAUBnCDRm. INTTAUBnIm is generated and the TAUBnTTOUTm signal (slave 3) is set.

When the counter of slave channel 3 reaches 0001_H , INTTAUBnIn is generated and the TAUBnTTOUTm signal is reset.

The delayed PWM pulse is output from slave channel 3.

The counter can be stopped by setting TAUBnTT.TAUBnTTm of master and slave channels to 1. This sets TAUBnTE.TAUBnTEm to 0. TAUBnCNTm and TAUBnTTOUTm of master and slave channels stop but their values are retained. The counter can be restarted by setting TAUBnTS.TAUBnTSm to 1.

Conditions Simultaneous rewrite can be used with this function. See Section 13.7, Simultaneous Rewrite.

Equations Pulse cycle = (TAUBnCDRm (master) + 1) × count clock cycle

Duty width 1 = (TAUBnCDRm (slave 1)) × count clock cycle

Delay width = (TAUBnCDRm (slave 2) + 1) × count clock cycle

Duty width 2 = (TAUBnCDRm (slave 3)) × count clock cycle

However, the delay width shall be set within the following range:
 $0000_H \leq \text{TAUBnCDRm (slave 2)} < \text{TAUBnCDRm (master)}$

Note 1. The waveform of TAUBnTTOUTm (slave 3) becomes the waveform made by delaying the waveform of TAUBnTTOUTm (slave 1) by the quantity generated by slave 2. It is impossible to make a delay longer than the pulse cycle.

Note 2. If INTTAUBnIm of slave 2 is generated while slave 3 is counting, slave 3 restarts operation. Therefore, the waveform of TAUBnTTOUTm (slave 3) is retained on the active level. In this case, TAUBnTTOUTm (slave 3) cannot output the waveform generated by delaying the basic pulse of TAUBnTTOUTm (slave 1).

(2) Block diagram and general timing diagram

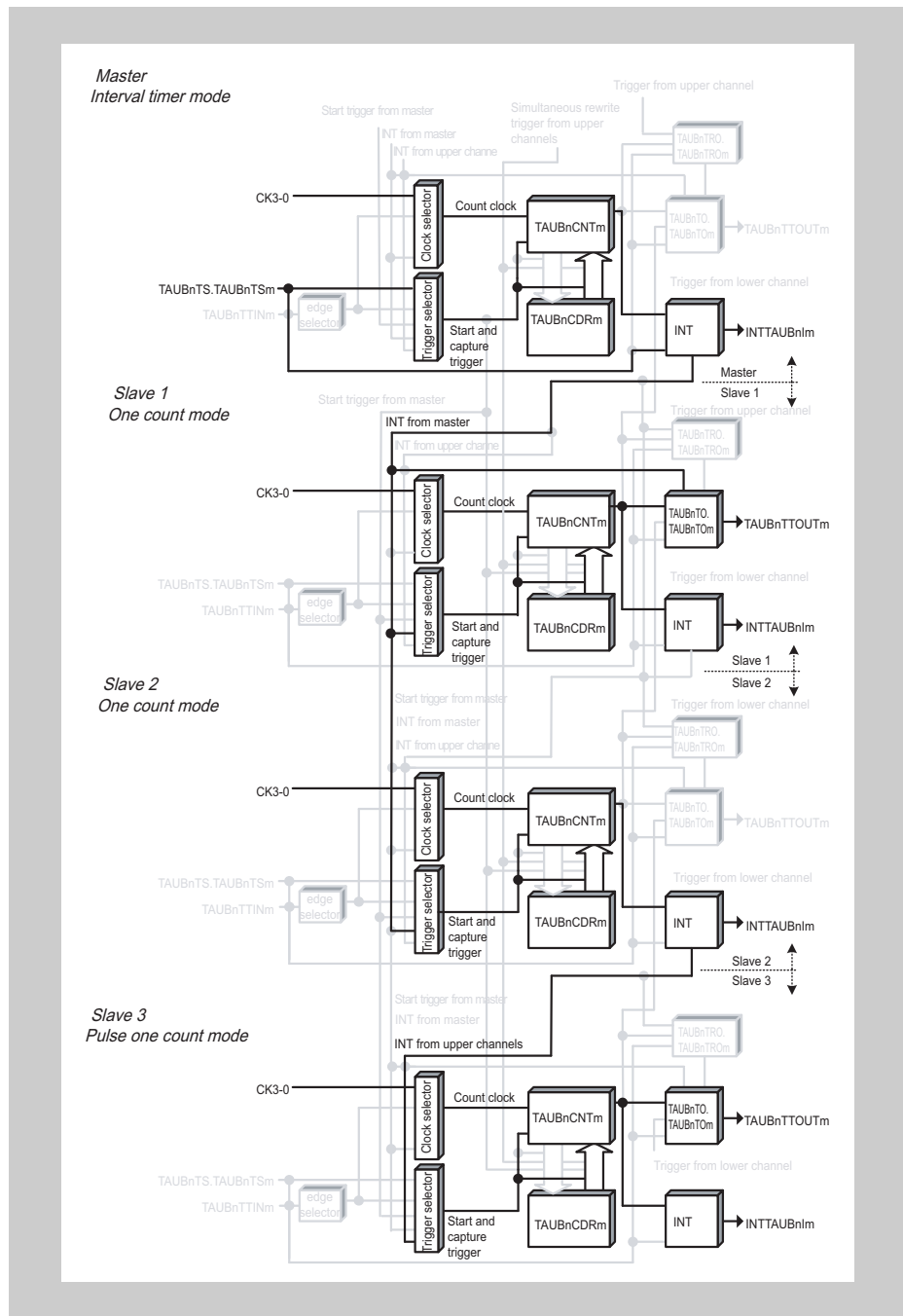

Figure 13-67 Block Diagram of Delay Pulse Output Function

The following settings apply to the general timing diagram.

- All channels
 - INTTAUBnIm is generated at the beginning of operation. (TAUBnCMORm.TAUBnMD0 = 1)

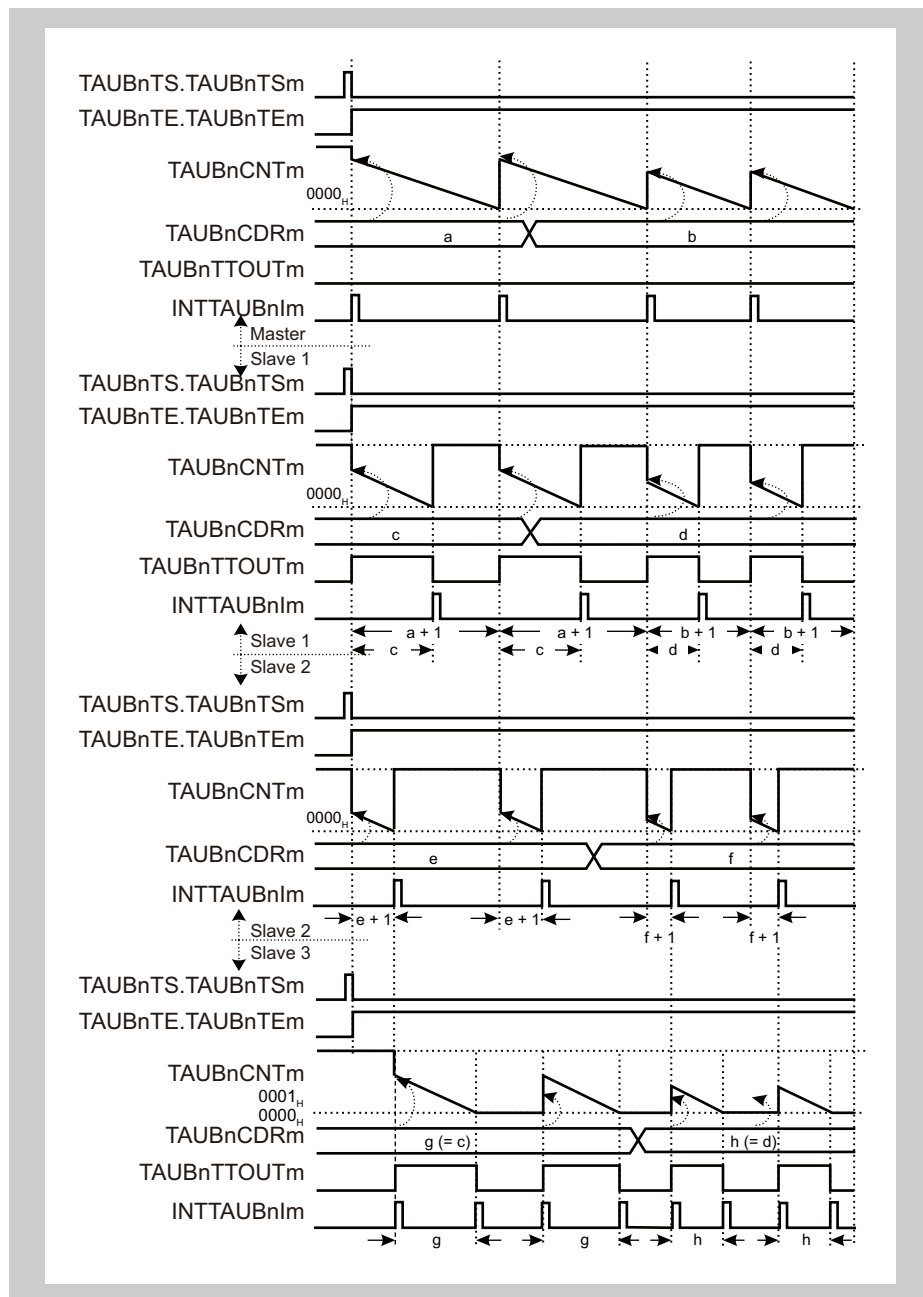

Figure 13-68 General Timing Diagram of Delay Pulse Output Function

(3) Register settings for master channels

(a) TAUBnCMORm for master channels

15	14	13	12	11	10	9	8	7	6	5	4	3	2	1	0
TAUBnCKS [1:0]	TAUBnCCS [1:0]	TAUBnMAS	TAUBnSTS[2:0]			TAUBnCOS [1:0]		-	TAUBnMD[4:1]				TAUBnMD0		

Table 13-75 TAUBnCMORm Settings for Master Channels of the Delay Pulse Output Function

Bit Name	Setting
TAUBnCKS[1:0]	00: Prescaler output CK0 01: Prescaler output CK1 10: Prescaler output CK2 11: Prescaler output CK3 TAUBnCKS[1:0] bits of master and slave channels should have the same value.
TAUBnCCS[1:0]	00: Uses an operation clock as a count clock.
TAUBnMAS	1: Master channel
TAUBnSTS[2:0]	000: Triggers the counter by software.
TAUBnCOS[1:0]	00: Unused. Set to 00.
TAUBnMD[4:1]	0000: Interval timer mode
TAUBnMD0	1: INTTAUBnIm is generated at the beginning of operation.

(b) TAUBnCMURm for master channels

7	6	5	4	3	2	1	0
-						TAUBnTIS[1:0]	

Table 13-76 TAUBnCMURm Settings for Master Channels of Delay Pulse Output Function

Bit Name	Setting
TAUBnTIS[1:0]	00: Unused. Set to 00.

(c) Channel output mode for master channels

TAUBnTOE.TAUBnTOEm is set to 0 because channel output mode is not used for master channels with this function. However, this mode can be used with another function or in independent channel output mode controlled by software.

(d) Simultaneous rewrite for master channels

Both master and slave channels should have the same simultaneous rewrite settings.

Table 13-77 Simultaneous Rewrite Settings for Master Channels of Delay Pulse Output Function

Bit Name	Setting
TAUBnRDE.TAUBnRDEm	1: Enables simultaneous rewrite.
TAUBnRDS.TAUBnRDSm	0: Master channel is simultaneous rewrite control channel.
TAUBnRDM.TAUBnRDMm	0: Generates a simultaneous rewrite trigger signal when master channel starts to count.
TAUBnRDC.TAUBnRDCm	0: INTTAUBnIm signal used to trigger a simultaneous rewrite is not monitored on the channel. When TAUBnRDS.TAUBnRDSm = 0, the master channel is monitored for simultaneous rewrite triggers regardless of the value of this bit.

(4) Register settings for slave channel 1

(a) TAUBnCMORm for slave channel 1

15	14	13	12	11	10	9	8	7	6	5	4	3	2	1	0
TAUBnCKS [1:0]	TAUBnCCS [1:0]	TAUBnMAS	TAUBnSTS[2:0]			TAUBnCOS [1:0]		-	TAUBnMD[4:1]				TAUBnMD0		

Table 13-78 TAUBnCMORm Settings for Slave Channel 1 of Delay Pulse Output Function

Bit Name	Setting
TAUBnCKS[1:0]	00: Prescaler output CK0 01: Prescaler output CK1 10: Prescaler output CK2 11: Prescaler output CK3 TAUBnCKS[1:0] bits of master and slave channels should have the same value.
TAUBnCCS[1:0]	00: Uses an operation clock as a count clock.
TAUBnMAS	0: Slave channel
TAUBnSTS[2:0]	100: INTTAUBnIm of master channel is a start trigger.
TAUBnCOS[1:0]	00: Unused. Set to 00.
TAUBnMD[4:1]	0100: One-count mode
TAUBnMD0	1: Valid start trigger during operation

(b) TAUBnCMURm for slave channel 1

7	6	5	4	3	2	1	0
-						TAUBnTIS[1:0]	

Table 13-79 TAUBnCMURm Settings for Slave Channel 1 of Delay Pulse Output Function

Bit Name	Setting
TAUBnTIS[1:0]	00: Unused. Set to 00.

(c) Channel output mode for slave channel 1**Table 13-80 Control Bit Settings for Slave Channel 1 in Synchronous Channel Output Mode 1**

Bit Name	Setting
TAUBnTOE.TAUBnTOEm	1: Enables independent channel output mode.
TAUBnTOM.TAUBnTOMm	1: Synchronous channel operation
TAUBnTOC.TAUBnTOCm	0: Operating mode 1
TAUBnTOL.TAUBnTOLm	0: Positive logic 1: Inverted logic
TAUBnTDE.TAUBnTDEm	0: Disables dead time operation.
TAUBnTDL.TAUBnTDLm	0: When disabling dead time operation (TAUBnTDE.TAUBnTDEm = 0), set these bits to 0.

(d) Simultaneous rewrite for slave channel 1

Both master and slave channels should have the same simultaneous rewrite settings.

Table 13-81 Simultaneous Rewrite Settings for Slave Channel 1 of Delay Pulse Output Function

Bit Name	Setting
TAUBnRDE.TAUBnRDEm	1: Enables simultaneous rewrite.
TAUBnRDS.TAUBnRDSm	0: Master channel is simultaneous rewrite control channel.
TAUBnRDM.TAUBnRDMm	0: Generates a simultaneous rewrite trigger signal when master channel starts to count.
TAUBnRDC.TAUBnRDCm	0: INTTAUBnIm signal used to trigger a simultaneous rewrite is not monitored on the channel. When TAUBnRDS.TAUBnRDSm = 0, the simultaneous rewrite trigger is monitored on the master channel regardless of the value of this bit.

(5) Register settings for slave channel 2

(a) TAUBnCMORm for slave channel 2

15	14	13	12	11	10	9	8	7	6	5	4	3	2	1	0
TAUBnCKS [1:0]	TAUBnCCS [1:0]	TAUBnMAS	TAUBnSTS[2:0]			TAUBnCOS [1:0]		-	TAUBnMD[4:1]				TAUBnMD0		

Table 13-82 TAUBnCMORm Settings for Slave Channel 2 of Delay Pulse Output Function

Bit Name	Setting
TAUBnCKS[1:0]	00: Prescaler output CK0 01: Prescaler output CK1 10: Prescaler output CK2 11: Prescaler output CK3 TAUBnCKS[1:0] bits of master and slave channels should have the same value.
TAUBnCCS[1:0]	00: Uses an operation clock as a count clock.
TAUBnMAS	0: Slave channel
TAUBnSTS[2:0]	100: INTTAUBnIm of master channel is a start trigger.
TAUBnCOS[1:0]	00: Unused. Set to 00.
TAUBnMD[4:1]	0100: One-count mode
TAUBnMD0	1: Valid start trigger during operation

(b) TAUBnCMURm for slave channel 2

7	6	5	4	3	2	1	0
-						TAUBnTIS[1:0]	

Table 13-83 TAUBnCMURm Settings for Slave Channel 2 of Delay Pulse Output Function

Bit Name	Setting
TAUBnTIS[1:0]	00: Unused. Set to 00.

(c) Channel output mode for slave channel 2

TAUBnTOE.TAUBnTOEm is set to 0 because channel output mode is not used with this function. However, this mode can be used with another function or in independent channel output mode controlled by software.

(d) Simultaneous rewrite for slave channel 2

Both master and slave channels should have the same simultaneous rewrite settings.

Table 13-84 Simultaneous Rewrite Settings for Slave Channel 2 of Delay Pulse Output Function

Bit Name	Setting
TAUBnRDE.TAUBnRDEm	1: Enables simultaneous rewrite.
TAUBnRDS.TAUBnRDSm	0: Master channel is simultaneous rewrite control channel.
TAUBnRDM.TAUBnRDMm	0: Generates a simultaneous rewrite trigger signal when master channel starts to count.
TAUBnRDC.TAUBnRDCm	0: INTTAUBnIm signal used to trigger a simultaneous rewrite is not monitored on the channel. When TAUBnRDS.TAUBnRDSm = 0, the master channel is monitored for simultaneous rewrite triggers regardless of the value of this bit.

(6) Register settings for slave channel 3

(a) TAUBnCMORm for slave channel 3

15	14	13	12	11	10	9	8	7	6	5	4	3	2	1	0
TAUBnCKS [1:0]	TAUBnCCS [1:0]	TAUBnMAS	TAUBnSTS[2:0]			TAUBnCOS [1:0]		-	TAUBnMD[4:1]				TAUBnMD0		

Table 13-85 TAUBnCMORm Settings for Slave Channel 3 of Delay Pulse Output Function

Bit Name	Setting
TAUBnCKS[1:0]	00: Prescaler output CK0 01: Prescaler output CK1 10: Prescaler output CK2 11: Prescaler output CK3 TAUBnCKS[1:0] bits of master and slave channels should have the same value.
TAUBnCCS[1:0]	00: Uses an operation clock as a count clock.
TAUBnMAS	0: Slave channel
TAUBnSTS[2:0]	101: INTTAUBnIm of upper channel (m - 1) is a start trigger regardless of master setting.
TAUBnCOS[1:0]	00: Unused. Set to 00.
TAUBnMD[4:1]	1010: Pulse one-count mode
TAUBnMD0	1: Valid start trigger during operation

(b) TAUBnCMURm for slave channel 3

7	6	5	4	3	2	1	0
-						TAUBnTIS[1:0]	

Table 13-86 TAUBnCMURm Settings for Slave Channel 3 of Delay Pulse Output Function

Bit Name	Setting
TAUBnTIS[1:0]	00: Unused. Set to 00.

(c) Channel output mode for slave channel 3**Table 13-87 Control Bit Settings in Independent Channel Output Mode 2**

Bit Name	Setting
TAUBnTOE.TAUBnTOEm	1: Enables independent channel output mode.
TAUBnTOM.TAUBnTOMm	0: Independent channel output
TAUBnTOC.TAUBnTOCm	1: Operating mode 2
TAUBnTOL.TAUBnTOLm	0: Positive logic 1: Inverted logic
TAUBnTDE.TAUBnTDEm	0: Disables dead time operation.
TAUBnTDL.TAUBnTDLm	0: When disabling dead time operation (TAUBnTDE.TAUBnTDEm = 0), set these bits to 0.

(d) Simultaneous rewrite for slave channel 3

The simultaneous rewrite settings of master and slave channels should be identical.

Table 13-88 Simultaneous Rewrite Settings for Slave channel 3 of Delay Pulse Output Function

Bit Name	Setting
TAUBnRDE.TAUBnRDEm	1: Enables simultaneous rewrite.
TAUBnRDS.TAUBnRDSm	0: Master channel is simultaneous rewrite control channel.
TAUBnRDM.TAUBnRDMm	0: Generates a simultaneous rewrite trigger signal when master channel starts to count.
TAUBnRDC.TAUBnRDCm	0: INTTAUBnIm signal used to trigger a simultaneous rewrite is not monitored on the channel. When TAUBnRDS.TAUBnRDSm = 0, the master channel is monitored for the simultaneous rewrite trigger regardless of the value of this bit.

(7) Operating procedure for delay pulse output function

Table 13-89 Operating Procedure for Delay Pulse Output Function (1/2)

	Operation	TAUBn Status
Initial Channel Setting	<p>Master channels: Set TAUBnCMORm and TAUBnCMURm registers and the channel output mode as described in (3) Register settings for master channels.</p> <p>Slave channel 1: Set TAUBnCMORm and TAUBnCMURm registers and the channel output mode as described in (4) Register settings for slave channel 1.</p> <p>Slave channel 2: Set TAUBnCMORm and TAUBnCMURm registers and the channel output mode as described in (5) Register settings for slave channel 2.</p> <p>Slave channel 3: set the TAUBnCMORm and TAUBnCMURm registers and the channel output mode as described in (6) Register settings for slave channel 3.</p> <p>Set TAUBnCDRm register value of every channel.</p>	Channel operation is stopped.

Table 13-89 Operating Procedure for Delay Pulse Output Function (2/2)

	Operation	TAUBn Status
Restart ↓	Start Operation Set TAUBnTS.TAUBnTSm of master and slave channels to 1 simultaneously. TAUBnTS.TAUBnTSm is a trigger bit, which is automatically cleared to 0.	TAUBnTE.TAUBnTEm (master and slave channels) is set to 1 and the counters of master channel and slave channels 1 and 2 start. INTTAUBnIm is generated on the master channel and TAUBnTTOUTm (slave channel 1) is set.
	During Operation TAUBnCDRm can be changed at any time. TAUBnCNTm and TAUBnRSF.RSFm can be read at any time. TAUBnRDT.TAUBnRDTm can be changed during operation.	TAUBnCNTm of master channel and slave channels 1 and 2 load TAUBnCDRm value and count down. When the counter of master channel reaches 0000 _H : <ul style="list-style-type: none"> • INTTAUBnIm (master) is generated. • TAUBnCDRm value is reloaded into TAUBnCNTm (master) to continue count operation. • TAUBnCDRm value is reloaded into TAUBnCNTm (slave 1/2) to start countdown. • TAUBnTTOUTm (slave 1) is set. When TAUBnCNTm (slave 1) reaches 0000 _H : <ul style="list-style-type: none"> • INTTAUBnIm (slave 1) is generated. • TAUBnTTOUTm (slave 1) is reset. When TAUBnCNTm (slave 2) reaches 0000 _H : <ul style="list-style-type: none"> • INTTAUBnIm (slave 2) is generated. • TAUBnTTOUTm (slave 3) is set. • TAUBnCDRm value is reloaded into TAUBnCNTm (slave 3) to start a countdown operation. When TAUBnCNTm (slave 3) reaches 0001 _H : <ul style="list-style-type: none"> • INTTAUBnIm (slave 3) is generated. • TAUBnTTOUTm (slave 3) is reset.
	Stop Operation Set TAUBnTT.TAUBnTTm of master and slave channels to 1 simultaneously. TAUBnTT.TAUBnTTm is a trigger bit, which is automatically cleared to 0.	TAUBnTE.TAUBnTEm is cleared to 0 and the counter stops. TAUBnCNTm and TAUBnTTOUTm stop and retain their current values.

(8) Specific timing diagrams**(a) Duty cycle (slave 3) = 100 %**

The following values apply to the figure below:

- TAUBnCDRm (master) = 000A_H
- TAUBnCDRm (slave 1) = 000B_H
- TAUBnCDRm (slave 2) = 0000_H
- TAUBnCDRm (slave 3) = 000B_H

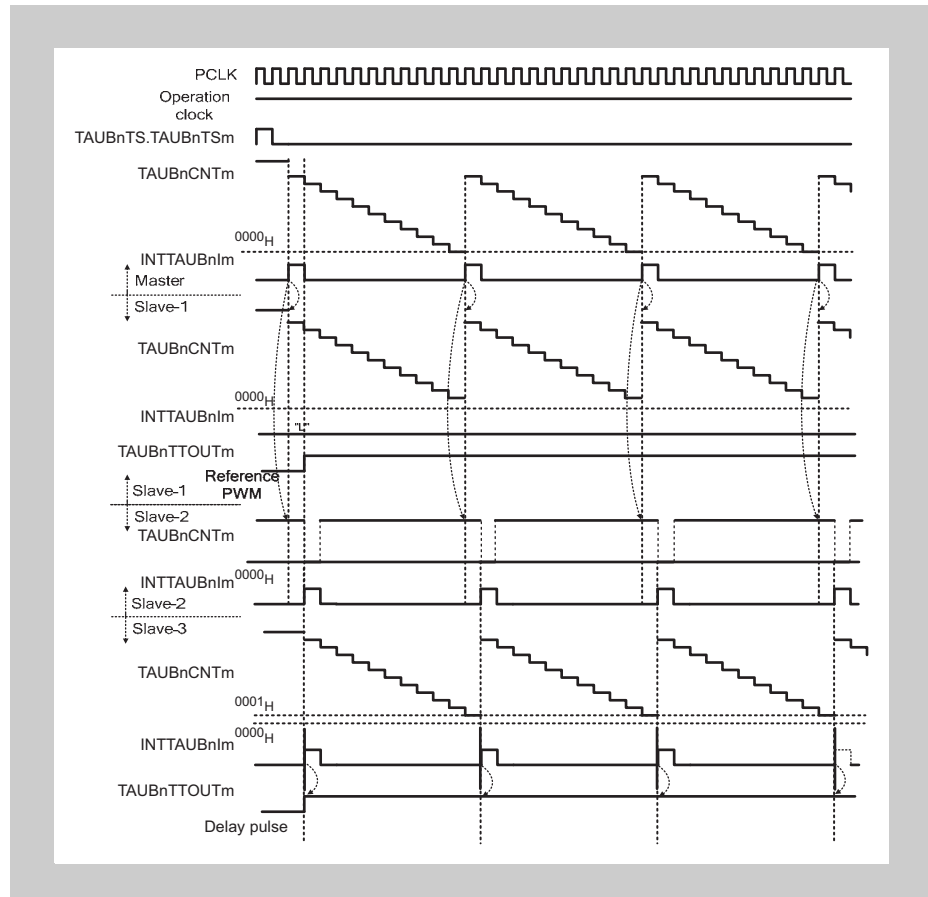

Figure 13-69 Duty Cycle (Slave 3) = 100 %

- If the value of TAUBnCDRm (slave 1 and 3) is higher than the value of TAUBnCDRm (master), the counter of the slave channels cannot reach 0000_H and cannot generate interrupts. TAUBnTTOUTm of channels 1 and 3 remain active.

(b)TAUBnTTOUTm (slave 1) = TAUBnTTOUTm (slave 3)

The following values apply to the figure below:

- TAUBnCDRm (master) = 000A_H
- TAUBnCDRm (slave 1) = 0005_H
- TAUBnCDRm (slave 2) = 0000_H
- TAUBnCDRm (slave 3) = 0005_H

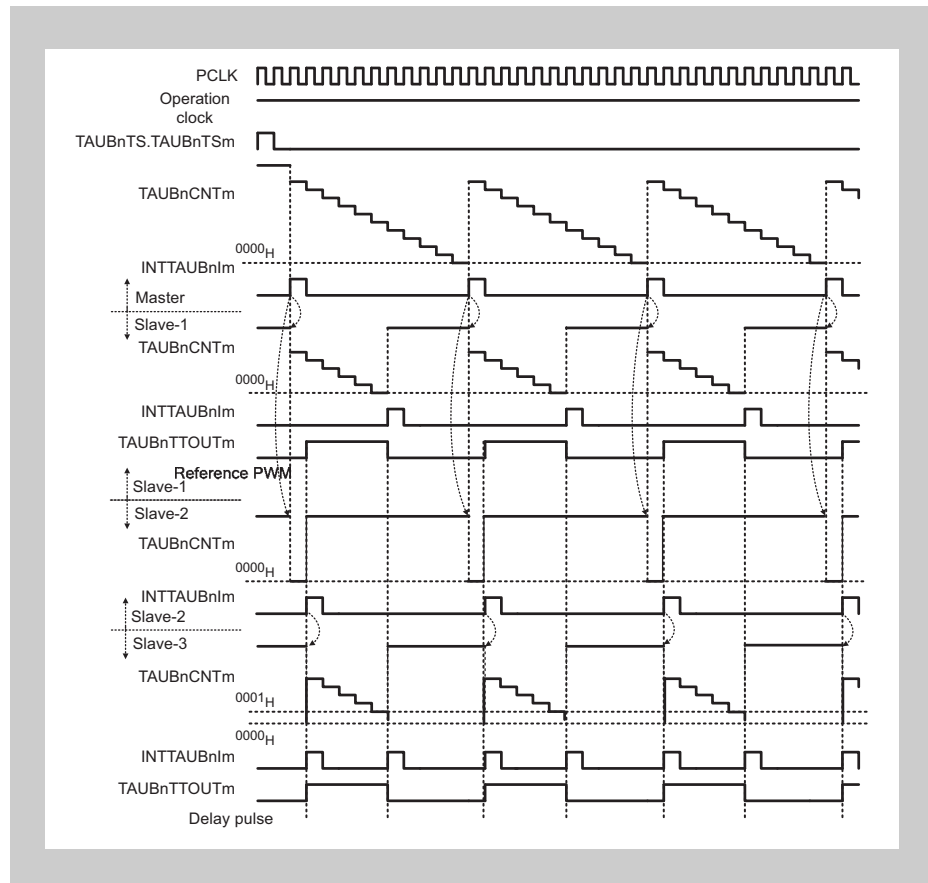

Figure 13-70 TAUBnTTOUTm (Slave 1) = TAUBnTTOUTm (Slave 3)

- If the value of TAUBnCDRm (slave 1 and 3) is higher than the value of TAUBnCDRm (master), the counter of the slave channels cannot reach 0000_H and cannot generate interrupts. TAUBnTTOUTm of channels 1 and 3 remain active.
If TAUBnCDRm (slave 2) = 0000_H, the counter of slave channel 3 starts counting one count clock later than the counter of slave channel 1. The reference pulse and the delay pulse are output with a delay of one clock count.

13.18.3 AD Conversion Trigger Output Function Type 1

(1) Overview

Summary This function is identical to Section 13.18.1, PWM Output Function, except that TAUBnTTOUTm is not output.

This is achieved by setting the channel output mode for the slave to independent channel output mode controlled by software.

(2) Block diagram and general timing diagram

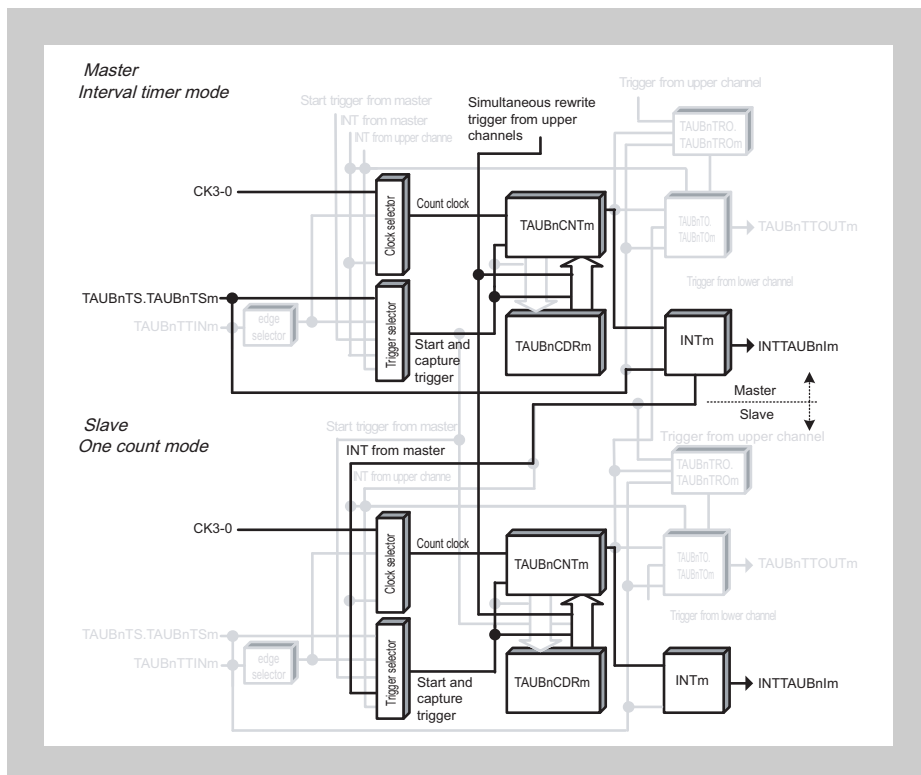

Figure 13-71 Block Diagram of AD Conversion Trigger Output Function Type 1

(3) General timing diagram

The following settings apply to the general timing diagram.

- Slave channels: Positive logic (TAUBnTOL.TAUBnTOLm = 0)

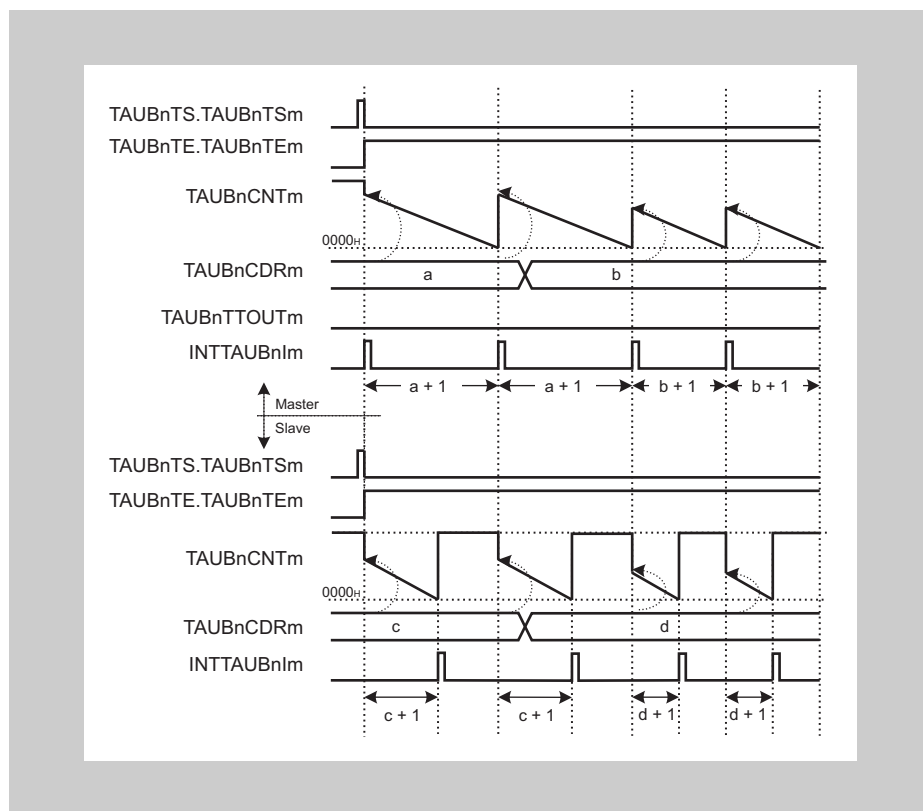

Figure 13-72 General Timing Diagram of AD Conversion Trigger Output Function Type 1

13.19 Synchronous PWM Signal Functions Triggered by an External Signal

This section describes functions that generate PWM signals and which are triggered by an external signal.

- Section 13.19.1, One-Shot Pulse Output Function

13.19.1 One-Shot Pulse Output Function

(1) Overview

- Summary** This function outputs a signal pulse with a specific pulse width and delay time (both defined relative to an external input signal pulse) by using a master and a slave channel. The delay time is specified using the master channel. The pulse width is specified using the slave channel.
- Prerequisites**
- Two channels
 - The operating mode for the master channel should be set to one-count mode. (See Table 13-90, TAUBnCMORm Settings for Master Channels of One-Shot Pulse Output Function.)
 - The operating mode for slave channels should be set to pulse one-count mode. (See Table 13-93, TAUBnCMORm Settings for Slave Channels of One-Shot Pulse Output Function.)
 - TAUBnTTOUTm is not used with the master channel of this function.
 - The channel output mode for the slave channel should be set to independent channel output mode 2. (See Section 13.8, Channel Output Modes.)
 - TAUBnTTINm (master) has to be detected while TAUBnCNTm (master) and TAUBnCNTm (slave) await a trigger. Furthermore, the slave is only triggered by an interrupt from the master channel and not by TAUBnTTINm (slave).
- Description** The counters are enabled by setting the channel trigger bits (TAUBnTS.TAUBnTSm) to 1. This sets TAUBnTE.TAUBnTEm, enabling count operation.
- Master channel:

When the next valid TAUBnTTINm input edge is detected, the current value of TAUBnCDRm is loaded into TAUBnCNTm. The counter starts to count down from this value. If TAUBnCMORm.MD0 = 0, a trigger (TAUBnTTINm) which is detected within the delay time is ignored.

When the counter of master channel reaches 0000_H, INTTAUBnIm is generated. The counter is reset to FFFF_H and waits for the next valid TAUBnTTINm input edge.
 - Slave channels:

INTTAUBnIm generated on master channel triggers the counter operation of slave channel. The current value of TAUBnCDRm (slave) is loaded into TAUBnCNTm (slave). The counter starts counting down from this value. An interrupt occurs and the TAUBnTTOUTm signal is set.

When the counter reaches 0001_H, INTTAUBnIm is generated and TAUBnTTOUTm signal is reset. The counter stops at 0000_H and waits for the next INTTAUBnIm of master channel.

The counter can be stopped by setting TAUBnTT.TAUBnTTm of master and slave channels to 1. This sets TAUBnTE.TAUBnTEm to 0. TAUBnCNTm and TAUBnTTOUTm of master and slave channels stop but their values are retained. The counter can be restarted by setting TAUBnTS.TAUBnTSm to 1.

Setting TAUBnTS.TAUBnTSm to 1 while counting allows the counter to restart counting of master channel without making a stop (forced restart).

Note 1. If a forced restart of the slave channel is executed during operation, the width of the output signal does not correspond to the value of TAUBnCDRm (slave).

Note 2. TAUBnTTINm input signal is sampled at the frequency of a sampling clock set by the TAUBnCMORm.TAUBnCKS[1:0] bits. As a result, the output cycle of TAUBnTTOUTm has an error of ± 1 operation clock cycle.

- Conditions**
- If TAUBnCMORn.TAUBnMD0 of master channel is set to 0, TAUBnTTINm input edges detected during counting are ignored.
 - Simultaneous rewrite can be used with this function. See Section 13.7, Simultaneous Rewrite.

Equations

Delay to input pulse = (TAUBnCDRm (master) + 1) × count clock cycle
Pulse width = (TAUBnCDRm (slave)) × count clock cycle

(2) Block diagram and general timing diagram

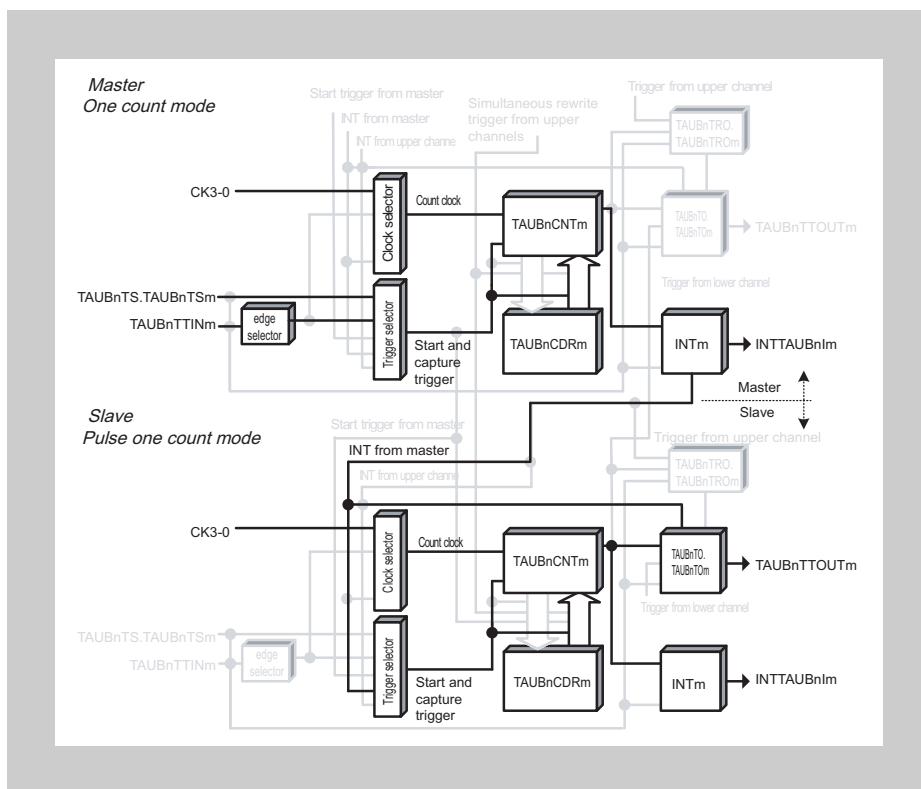

Figure 13-73 Block Diagram of One-Shot Pulse Output Function

The following settings apply to the general timing diagram.

- Start trigger detection is disabled during counting (TAUBnCMORM.TAUBnMD0 = 0)
- Detection of falling edge (TAUBnCMURm.TAUBnTIS[1:0] = 00_B)

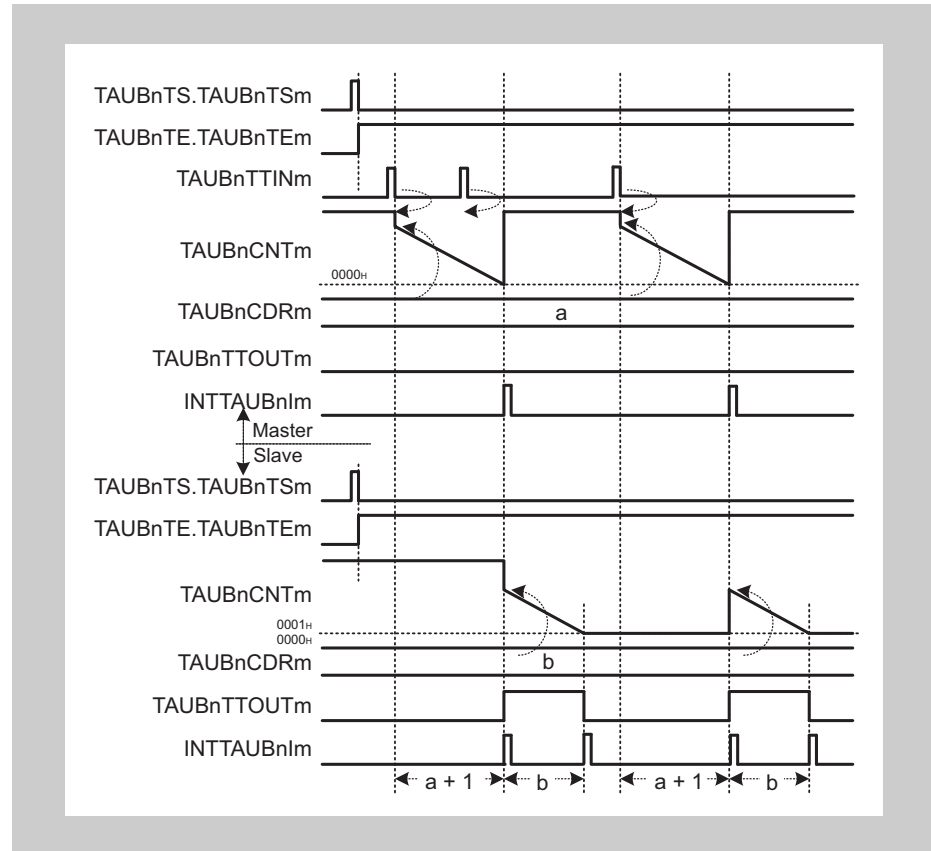

Figure 13-74 General Timing Diagram of One-Shot Pulse Output Function

(3) Register settings for master channels

(a) TAUBnCMORm for master channels

15	14	13	12	11	10	9	8	7	6	5	4	3	2	1	0
TAUBnCKS [1:0]	TAUBnCCS [1:0]	TAUBnMAS	TAUBnSTS[2:0]		TAUBnCOS [1:0]		-	TAUBnMD[4:1]				TAUBnMD0			

Table 13-90 TAUBnCMORm Settings for Master Channels of One-Shot Pulse Output Function

Bit Name	Setting
TAUBnCKS[1:0]	00: Prescaler output CK0 01: Prescaler output CK1 10: Prescaler output CK2 11: Prescaler output CK3 TAUBnCKS[1:0] bits of master and slave channels should have the same value.
TAUBnCCS[1:0]	00: Uses an operation clock as a count clock.
TAUBnMAS	1: Master channel
TAUBnSTS[2:0]	001: Valid TAUBnTTINm input edge signal is used as a start trigger.
TAUBnCOS[1:0]	00: Unused. Set to 00.
TAUBnMD[4:1]	0100: One-count mode
TAUBnMD0	0: Disables detection of start trigger during count operation. 1: Enables detection of start trigger during count operation. MD0 bit of master and slave channels should have the same value.

(b) TAUBnCMURm for master channels

7	6	5	4	3	2	1	0
-						TAUBnTIS[1:0]	

Table 13-91 TAUBnCMURm Settings for Master Channels of One-Shot Pulse Output Function

Bit Name	Setting
TAUBnTIS[1:0]	00: Detection of falling edge 01: Detection of rising edge 10: Detection of falling and rising edges 11: Setting prohibited.

(c) Channel output mode for master channels

TAUBnTOE.TAUBnTOEm is set to 0 because channel output mode is not used with this function. However, this mode can be used with another function or in independent channel output mode controlled by software.

(d) Simultaneous rewrite for master channels

The simultaneous rewrite settings for master and slave channel should be identical.

Table 13-92 Simultaneous Rewrite Settings for Master Channels of One-Shot Pulse Output Function

Bit Name	Setting
TAUBnRDE.TAUBnRDEm	1: Enables simultaneous rewrite.
TAUBnRDS.TAUBnRDSm	0: Master channel is simultaneous rewrite control channel.
TAUBnRDM.TAUBnRDMm	0: Generates a simultaneous rewrite trigger signal when master channel starts to count.
TAUBnRDC.TAUBnRDCm	0: INTTAUBnIm signal used to trigger a simultaneous rewrite is not monitored on the channel. When TAUBnRDS.TAUBnRDSm = 0, the master channel is monitored for simultaneous rewrite triggers regardless of the value of this bit.

(4) Register settings for slave channels

(a) TAUBnCMORm for slave channels

15	14	13	12	11	10	9	8	7	6	5	4	3	2	1	0
TAUBnCKS [1:0]	TAUBnCCS [1:0]	TAUBnMAS	TAUBnSTS[2:0]			TAUBnCOS [1:0]		-	TAUBnMD[4:1]				TAUBnMD0		

Table 13-93 TAUBnCMORm Settings for Slave Channels of One-Shot Pulse Output Function

Bit Name	Setting
TAUBnCKS[1:0]	00: Prescaler output CK0 01: Prescaler output CK1 10: Prescaler output CK2 11: Prescaler output CK3 TAUBnCKS[1:0] bits of master and slave channels should have the same value.
TAUBnCCS[1:0]	00: Uses an operation clock as a count clock.
TAUBnMAS	0: Slave channel
TAUBnSTS[2:0]	100: INTTAUBnIm of master channel is a start trigger.
TAUBnCOS[1:0]	00: Unused. Set to 00.
TAUBnMD[4:1]	1010: Pulse one-count mode
TAUBnMD0	0: Disables detection of start trigger during count operation. 1: Enables detection of start trigger during count operation. MD0 bit of master and slave channels should have the same value.

(b) TAUBnCMURm for slave channels

7	6	5	4	3	2	1	0
-						TAUBnTIS[1:0]	

Table 13-94 TAUBnCMURm Settings for Slave Channels of One-Shot Pulse Output Function

Bit Name	Setting
TAUBnTIS[1:0]	00: Unused. Set to 00.

(c) Output mode for slave channels**Table 13-95 Control Bit Settings in Independent Channel Output Mode 2**

Bit Name	Setting
TAUBnTOE.TAUBnTOEm	1: Enables independent channel output mode.
TAUBnTOM.TAUBnTOMm	0: Independent channel output
TAUBnTOC.TAUBnTOCm	1: Operating mode 2
TAUBnTOL.TAUBnTOLm	0: Positive logic 1: Inverted logic
TAUBnTDE.TAUBnTDEm	0: Disables dead time operation.
TAUBnTDL.TAUBnTDLm	0: When disabling dead time operation (TAUBnTDE.TAUBnTDEm = 0), set this bit to 0.

(d) Simultaneous rewrite for slave channels

Both master and slave channels should have the same simultaneous rewrite settings.

Table 13-96 Simultaneous Rewrite Settings for Slave Channels of One-Shot Pulse Output Function

Bit Name	Setting
TAUBnRDE.TAUBnRDEm	1: Enables simultaneous rewrite.
TAUBnRDS.TAUBnRDsm	0: Master channel is simultaneous rewrite control channel.
TAUBnRDM.TAUBnRDMm	0: Generates a simultaneous rewrite trigger signal when master channel starts to count.
TAUBnRDC.TAUBnRDCm	0: Channel is not monitored for INTTAUBnIm signals used to trigger a simultaneous rewrite. When TAUBnRDS.TAUBnRDsm = 0, the master channel is monitored for simultaneous rewrite triggers regardless of the value of this bit.

(5) Operating procedure for one-shot pulse output function

Table 13-97 Operating Procedure for One-Shot Pulse Output Function

	Operation	TAUBn Status
Restart	Initial Channel Setting	Channel operation is stopped.
	Start Operation	TAUBnTE.TAUBnTEm (master and slave channels) is set to 1 and the master channel awaits a TAUBnTTINm input.
	During Operation	<p>When valid TAUBnTTINm input edge is detected, TAUBnCDRm value of master channel is loaded into TAUBnCNTm to start countdown. When the counter reaches 0000_H:</p> <ul style="list-style-type: none"> • INTTAUBnIm (master) is generated. • TAUBnCNTm (master) returns to FFFF_H again and waits for the next valid TAUBnTTINm input edge. • TAUBnCDRm value is reloaded into TAUBnCNTm (slave) to start countdown. • INTTAUBnIm (slave) is generated. • TAUBnTTOUTm (slave) is set. <p>When TAUBnCNTm (slave) reaches 0001_H:</p> <ul style="list-style-type: none"> • INTTAUBnIm (slave) is generated. • TAUBnTTOUTm (slave) is reset. <p>If TAUBnTTINm input is detected on the master channel during count operation and TAUBnCMORm.TAUBnMD0 = 0, the input is ignored.</p>
	Stop Operation	TAUBnTE.TAUBnTEm is cleared to 0 and the counter stops. TAUBnCNTm and TAUBnTTOUTm stop, and retain their current values.

(6) Specific timing diagrams**(a) TAUBnCDRm (master) = 0000_H**

The following settings apply to this diagram:

- Start trigger detection disabled during counting (TAUBnCMORm.TAUBnMD0 = 0)
- Falling edge detection (TAUBnCMURm.TAUBnTIS[1:0] = 00_B)

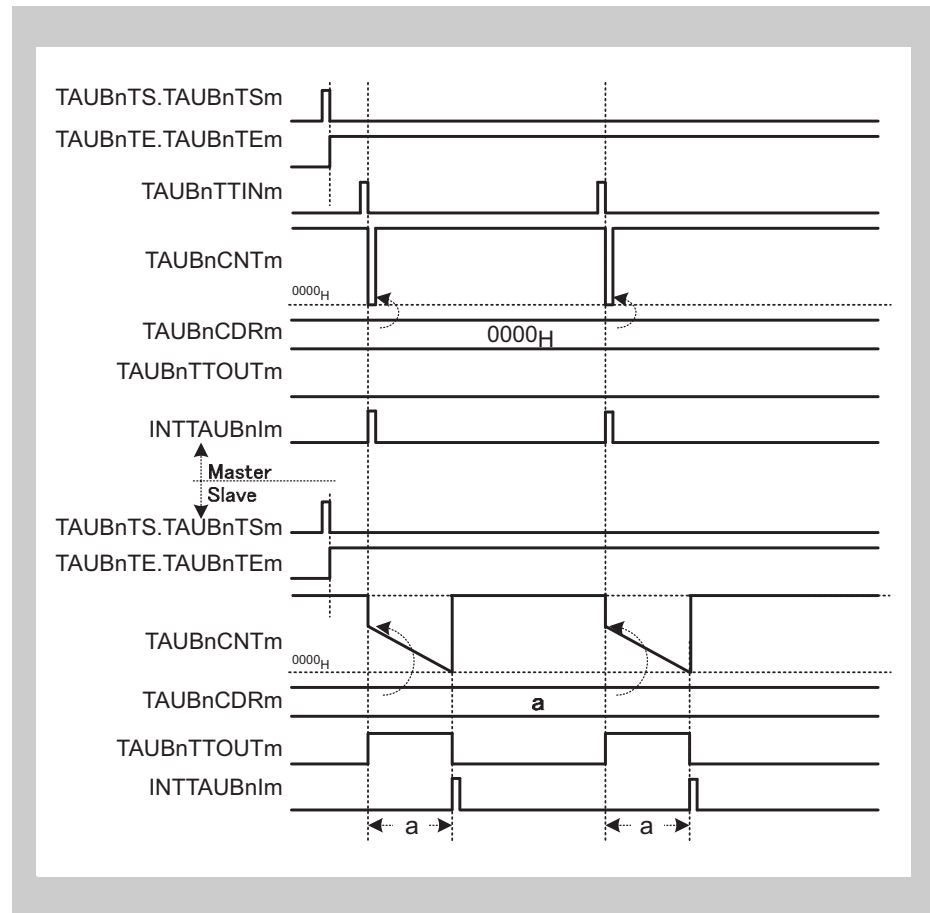

Figure 13-75 TAUBnCDRm (Master) = 0000_H

- When a valid TAUBnTTINm input edge is detected, the value 0000_H is written to TAUBnCNTm (master). The counter is set to 0000_H for one count and returns to FFFF_H.

Thus the slave channel starts to count down one count clock later than TAUBnTTINm (master).

(b) TAUBnCDRm (slave) = 0000_H

The following settings apply to this diagram:

- Start trigger detection disabled during counting (TAUBnCMORm.TAUBnMD0 = 0)
- Falling edge detection (TAUBnCMURm.TAUBnTIS[1:0] = 00_B)

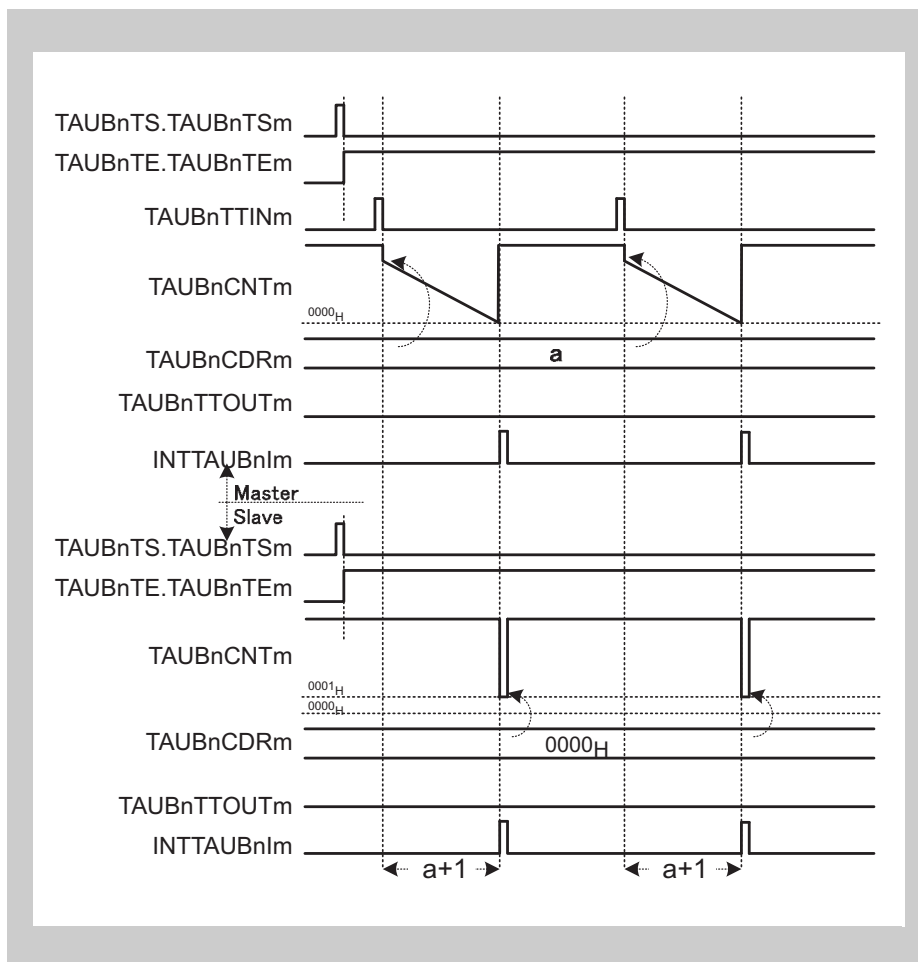

Figure 13-76 TAUBnCDRm (Slave) = 0000_H

- The counter of the slave channel reloads the value 0000_H and returns to FFFF_H one clock count later.
TAUBnTTOUTm remains inactive, because the pulse width is zero.

(c) **TAUBnCMORm.TAUBnMD0 = 1**

The following settings apply to this diagram:

- Start trigger detection enabled during counting (TAUBnCMORm.TAUBnMD0 = 1)
- Falling edge detection (TAUBnCMURm.TAUBnTIS[1:0] = 00_B)

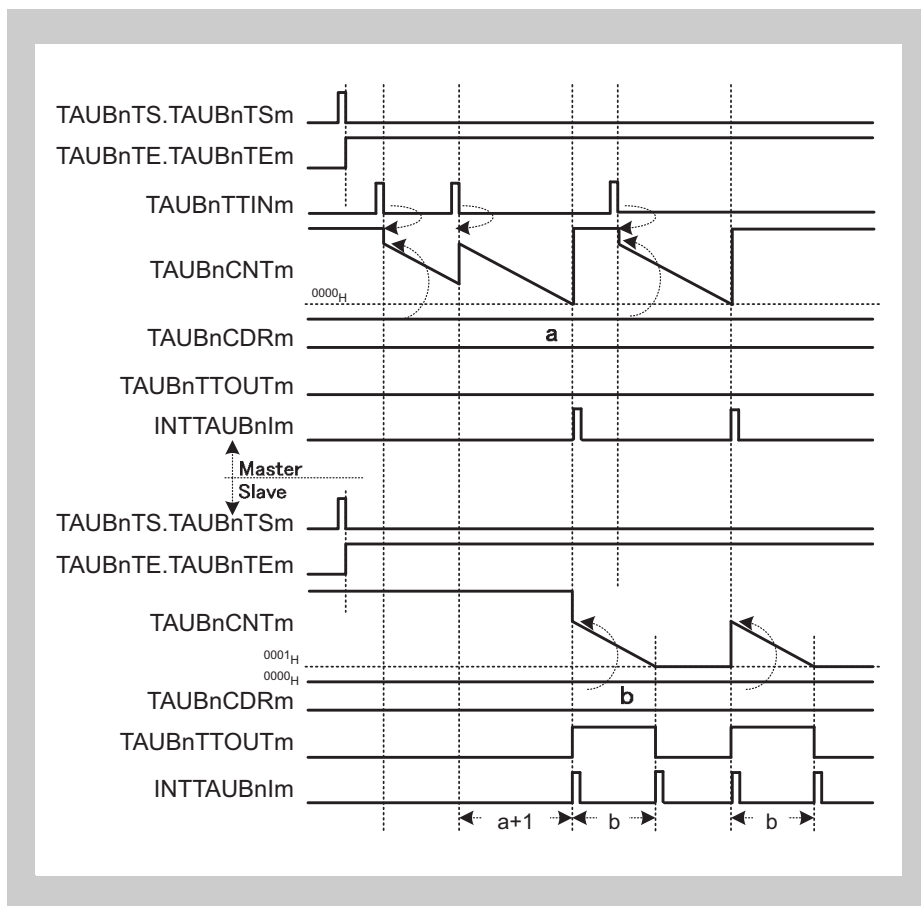

Figure 13-77 **TAUBnCMORm.TAUBnMD0 = 1**

- If a valid TAUBnTTINm input edge is detected while the counter of the master channel counts down, TAUBnCNTm reloads the value of TAUBnCDRm. The counter restarts to count down.

This means the delay of interrupt generation interval is extended by the value of TAUBnCNTm at the time a valid TAUBnTTINm input edge is detected.

(d) Restarting the master channel while the slave channel is counting

The following settings apply to this diagram:

- Start trigger detection disabled during counting (TAUBnCMORm.TAUBnMD0 = 0)
- Falling edge detection (TAUBnCMURm.TAUBnTIS[1:0] = 00_B)

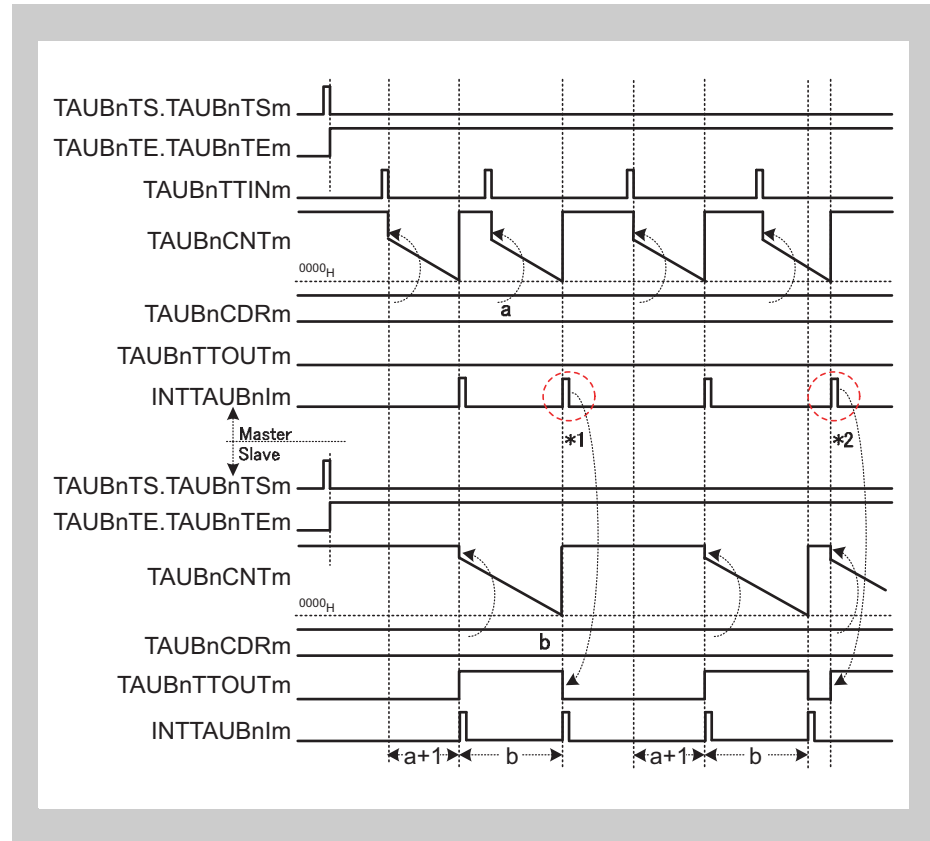

Figure 13-78 Interval of TAUBnTTINm ≤ Delay Time + Pulse Width + 1

- If the master channel generates an interrupt before the counter of the slave channel has reached 0001_H or exactly when 0001_H is reached (*1), the interrupt (master) is ignored.
- If an interrupt of the master channel occurs when the counter of the slave channel waits for the next trigger, the value of TAUBnCDRm (slave) is reloaded. An interrupt is generated and TAUBnTTOUTm is toggled. If TAUBnCNTm (master) has started to count down while the TAUBnCNTm (slave) is still counting (*2), TAUBnTTOUTm is not output with the expected delay time.
- To generate correct one-shot pulse, the start trigger for the master channel must be detected while the master and slave channels are not counting but waiting for the start trigger.

13.20 Synchronous Triangle PWM Functions

This chapter describes functions that generate a triangle PWM output.

- Section 13.20.1, Triangle PWM Output Function
- Section 13.20.2, Triangle PWM Output Function with Dead Time
- Section 13.20.3, AD Conversion Trigger Output Function Type 2

13.20.1 Triangle PWM Output Function

(1) Overview

Summary This function generates multiple triangle PWM outputs by using a master and one or more slave channels. It enables the pulse cycle (frequency) and the duty cycle of TAUBnTTOUTm to be set using the master and slave channels respectively.

The master channel generates a carrier cycle. The first cycle of master channel controls the down status and the second cycle controls the up status of the slave counter.

- Prerequisites**
- Two channels
 - The operating mode for master channels should be set to interval timer mode. (See Table 13-98, TAUBnCMORm Settings for Master Channels of Triangle PWM Output Function.)
 - The operating mode for slave channels should be set up/down count mode. (See Table 13-102, TAUBnCMORm Settings for Slave Channels of Triangle PWM Output Function.)
 - The channel output mode for master channels should be set to independent channel output mode 1. (See Section 13.8, Channel Output Modes.)
 - The channel output mode for slave channels should be set to synchronous channel output mode 2. (See Section 13.8, Channel Output Modes.)
 - The following settings allows TAUBnTTOUTm to be at high level during the down status of a carrier cycle.
 - If TAUBnCMORm.TAUBnMD0 (master) bit is set to 0, TAUBnTO.TAUBnTOM should be set to 1 while TAUBnTOE.TAUBnTOEm is set to 0 (recommended setting).
 - If TAUBnCMORm.TAUBnMD0 (master) bit is set to 1, TAUBnTO.TAUBnTOM should be set to 0 while TAUBnTOE.TAUBnTOEm is set to 0 (recommended setting).

- Description** The counters are started by setting the channel trigger bit (TAUBnTS.TAUBnTSM) to 1 for every channel. This in turn sets TAUBnTE.TAUBnTEm, enabling count operation. The current values of TAUBnCDRm (master and slave) are loaded into TAUBnCNTm (master and slave) and the counters start counting down from these values. When the TAUBnCMORm.TAUBnMD0 bit of master channel is set to 1, an interrupt is generated and TAUBnTTOUTm signal of master toggles.
- Master channels:

When the counter of master channel reaches 0000_H (pulse cycle time has elapsed), INTTAUBnIm is generated and the TAUBnTTOUTm signal toggles. TAUBnCNTm then reloads the TAUBnCDRm value and counts down.

- Slave channels:

The INTTAUBnIm of master channel triggers the counter of the slave channel:

- If the slave counter is counting down, the count direction changes.
- If the slave counter is counting up, TAUBnCDRm value is reloaded and the counter starts to count down.

When the counter of the slave channel reaches 0001_H while counting up or down, INTTAUBnIm is generated and the TAUBnTTOUTm (slave) signal is set/reset.

The counter continues count-up/-down and waits for the next INTTAUBnIm of master channel.

Setting TAUBnTOL.TAUBnTOLm allows TAUBnTTOUTm signal switching between normal phase and reverse phase during operation.

The counter can be stopped by setting TAUBnTT.TAUBnTTm of master and slave channels to 1. This sets TAUBnTE.TAUBnTEm = 0. TAUBnCNTm and TAUBnTTOUTm of master and slave channels stop but retain their values.

Note If a forced restart is executed during operation, TAUBnTTOUTm is not output as a triangle PWM wave signal.

Conditions This function enables simultaneous rewrite. See Section 13.7, Simultaneous Rewrite.

(2) Equations

Pulse cycle = (TAUBnCDRm (master) + 1) × count clock cycle

0000_H ≤ TAUBnCDRm (master) < FFFF_H

Carrier cycle (down/up) = (TAUBnCDRm (master) + 1) × 2 × count clock cycle

Duty cycle [%] =

$$\frac{[(\text{TAUBnCDRm (master)} + 1 - \text{TAUBnCDRm (slave)}) / (\text{TAUBnCDRm (master)} + 1)] \times 100}{}$$

- Duty cycle = 100 %

TAUBnCDRm (slave) = 0000_H

- Duty cycle = 0 %

TAUBnCDRm (slave) ≥ TAUBnCDRm (master) + 1

(3) Block diagram and general timing diagram

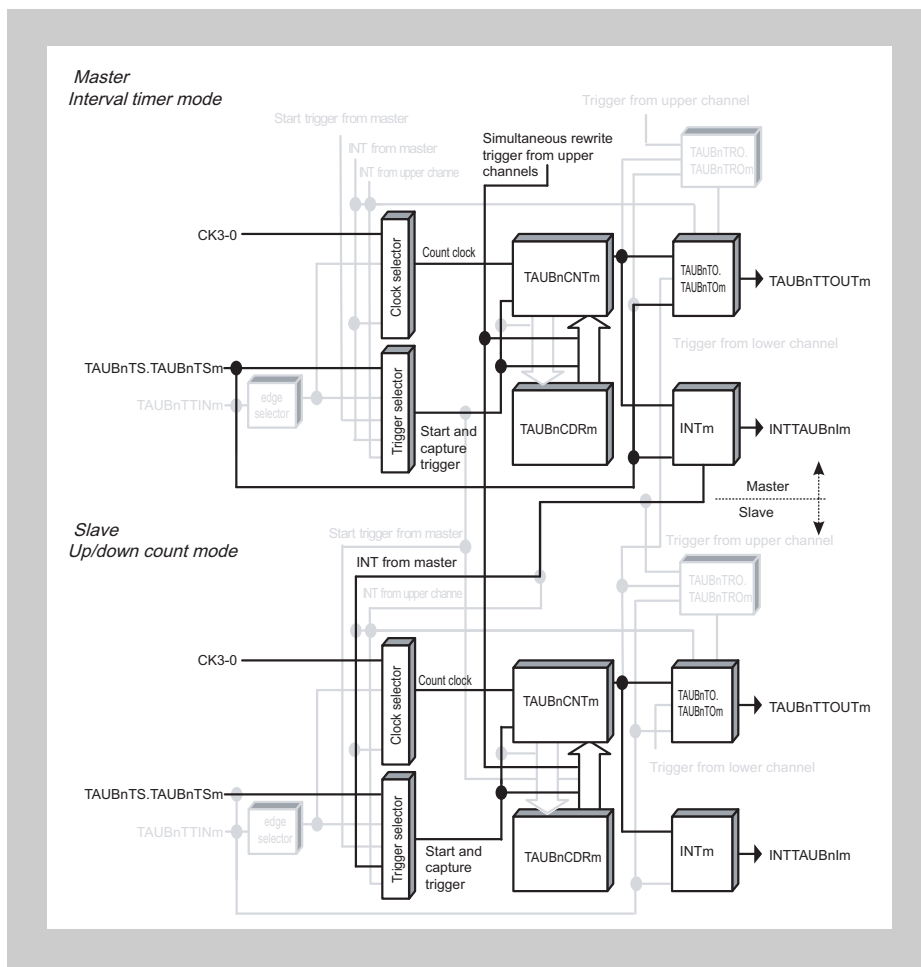

Figure 13-79 Block Diagram of Triangle PWM Output Function

The following settings apply to the general timing diagram.

- Master channel
 - INTTAUBnIm is generated at the beginning of operation. (TAUBnCMORm.TAUBnMD0 = 1)

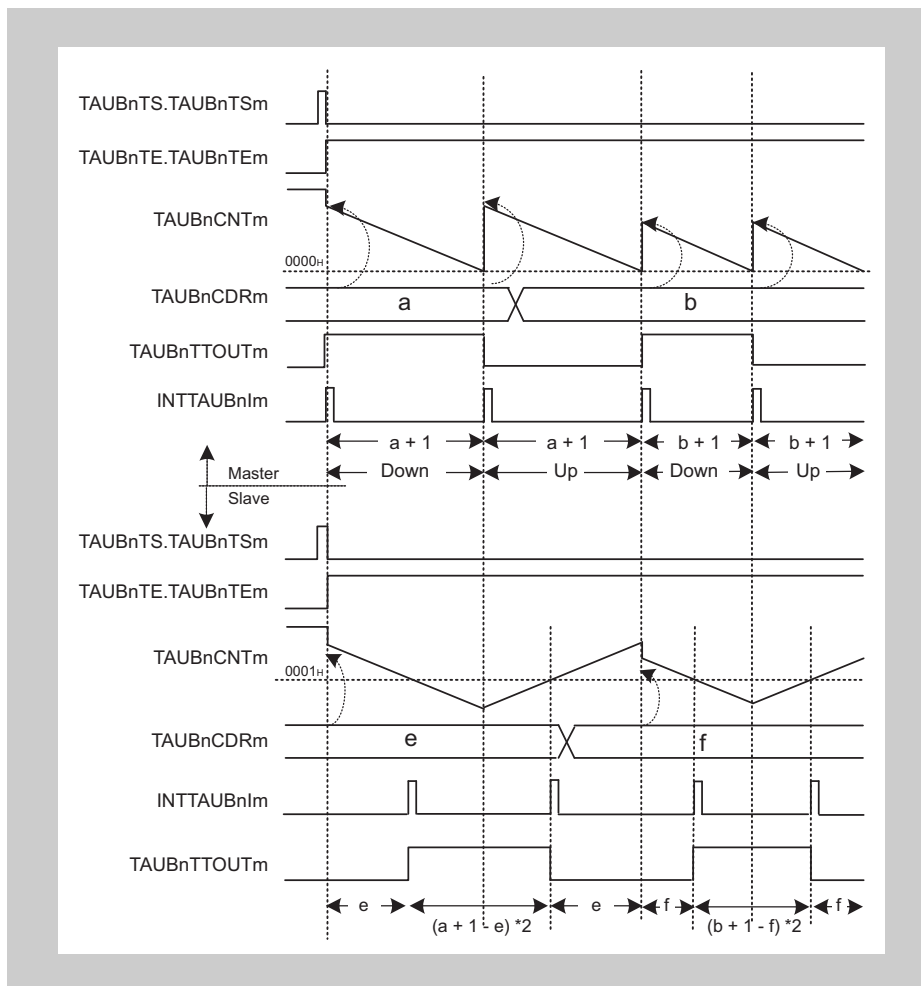

Figure 13-80 General Timing Diagram of Triangle PWM Output Function

(4) Register settings for master channels

(a) TAUBnCMORm for master channels

15	14	13	12	11	10	9	8	7	6	5	4	3	2	1	0
TAUBnCKS [1:0]	TAUBnCCS [1:0]	TAUBnMAS	TAUBnSTS[2:0]			TAUBnCOS [1:0]		-	TAUBnMD[4:1]				TAUBnMD0		

Table 13-98 TAUBnCMORm Settings for Master Channels of Triangle PWM Output Function

Bit Name	Setting
TAUBnCKS[1:0]	00: Prescaler output CK0 01: Prescaler output CK1 10: Prescaler output CK2 11: Prescaler output CK3 TAUBnCKS[1:0] bits of master and slave channels should have the same value.
TAUBnCCS[1:0]	00: Uses an operation clock as a count clock.
TAUBnMAS	1: Master channel
TAUBnSTS[2:0]	000: Triggers the counter by software.
TAUBnCOS[1:0]	00: Unused. Set to 00.
TAUBnMD[4:1]	0000: Interval timer mode
TAUBnMD0	0: INTTAUBnIm is not generated and TAUBnTTOUTm is not toggled at the beginning of operation. 1: INTTAUBnIm is generated and TAUBnTTOUTm is toggled at the beginning of operation.

(b) TAUBnCMURm for master channels

7	6	5	4	3	2	1	0
-						TAUBnTIS[1:0]	

Table 13-99 TAUBnCMURm Settings for Master Channels of Triangle PWM Output Function

Bit Name	Setting
TAUBnTIS[1:0]	00: Unused. Set to 00.

(c) Channel output mode for master channels**Table 13-100 Control Bit Settings in Independent Channel Output Mode 1**

Bit Name	Setting
TAUBnTOE.TAUBnTOEm	1: Enables independent channel output mode.
TAUBnTOM.TAUBnTOMm	0: Independent channel output
TAUBnTOC.TAUBnTOCm	0: Operating mode 1 (Toggle mode when TAUBnTOM.TAUBnTOMm = 0)
TAUBnTOL.TAUBnTOLm	0: Positive logic
TAUBnTDE.TAUBnTDEm	0: Disables dead time operation.
TAUBnTDL.TAUBnTDLm	0: When disabling dead time operation (TAUBnTDE.TAUBnTDEm = 0), set these bits to 0.

(d) Simultaneous rewrite for master channels

The simultaneous rewrite settings of master and slave channels should be identical.

Table 13-101 Simultaneous Rewrite Settings for Master Channels of Triangle PWM Output Function

Bit Name	Setting
TAUBnRDE.TAUBnRDEm	1: Enables simultaneous rewrite.
TAUBnRDS.TAUBnRDSm	0: Monitors master channel for simultaneous rewrite triggers. 1: Monitors upper channel other than the channel group for simultaneous rewrite triggers.
TAUBnRDM.TAUBnRDMm	1: A simultaneous rewrite trigger signal is generated when master channel starts to count and the corresponding slave channel is at the peak of a triangular wave.
TAUBnRDC.TAUBnRDCm	0: Channel is not monitored for INTTAUBnIm signals used as simultaneous rewrite triggers. If TAUBnRDS.TAUBnRDSm = 0, master channel is monitored for simultaneous rewrite triggers regardless of the value of this bit.

Note If TAUBnRDS.TAUBnRDSm = 1, it is necessary for an upper channel higher than a master channel to generate a simultaneous rewrite trigger signal.

(5) Register settings for slave channels

(a) TAUBnCMORm for slave channels

15	14	13	12	11	10	9	8	7	6	5	4	3	2	1	0
TAUBnCKS [1:0]	TAUBnCCS [1:0]	TAUBnMAS	TAUBnSTS[2:0]			TAUBnCOS [1:0]		-	TAUBnMD[4:1]				TAUBnMD0		

Table 13-102 TAUBnCMORm Settings for Slave Channels of Triangle PWM Output Function

Bit Name	Setting
TAUBnCKS[1:0]	00: Prescaler output CK0 01: Prescaler output CK1 10: Prescaler output CK2 11: Prescaler output CK3 TAUBnCKS[1:0] bits of master and slave channels should have the same value.
TAUBnCCS[1:0]	00: Uses an operation clock as a count clock.
TAUBnMAS	0: Slave channel
TAUBnSTS[2:0]	111: Up/down output trigger signal of master channel
TAUBnCOS[1:0]	00: Unused. Set to 00.
TAUBnMD[4:1]	1001: Up/down count mode
TAUBnMD0	0: INTTAUBnIm is not generated at the beginning of operation.

(b) TAUBnCMURm for slave channels

7	6	5	4	3	2	1	0
-						TAUBnTIS[1:0]	

Table 13-103 TAUBnCMURm Settings for Slave Channels of Triangle PWM Output Function

Bit Name	Setting
TAUBnTIS[1:0]	00: Unused. Set to 00.

(c) Channel output mode for slave channels**Table 13-104 Control Bit Settings in Synchronous Channel Output Mode 2**

Bit Name	Setting
TAUBnTOE.TAUBnTOEm	1: Enables independent channel output mode.
TAUBnTOM.TAUBnTOMm	1: Synchronous channel operation
TAUBnTOC.TAUBnTOCm	1: Operating mode 2
TAUBnTOL.TAUBnTOLm	0: Positive logic 1: Inverted logic
TAUBnTDE.TAUBnTDEm	0: Disables dead time operation.
TAUBnTDL.TAUBnTDLm	0: When disabling dead time operation (TAUBnTDE.TAUBnTDEm = 0), set these bits to 0.

(d) Simultaneous rewrite for slave channels

Both master and slave channels should have the same simultaneous rewrite settings.

Table 13-105 Simultaneous Rewrite Settings for Slave Channels of Triangle PWM Output Function

Bit Name	Setting
TAUBnRDE.TAUBnRDEm	1: Enables simultaneous rewrite.
TAUBnRDS.TAUBnRDSm	0: Monitors master channel for simultaneous rewrite triggers. 1: Monitors upper channel other than the channel group for simultaneous rewrite triggers.
TAUBnRDM.TAUBnRDMm	1: Simultaneous rewrite trigger signal is generated when master channel starts to count and the corresponding slave channel is at the peak of a triangular wave.
TAUBnRDC.TAUBnRDCm	0: Channel is not monitored for INTTAUBnIm signals used as simultaneous rewrite triggers. If TAUBnRDS.TAUBnRDSm = 0, master channel is monitored for simultaneous rewrite triggers regardless of the value of this bit.

(6) Operating procedure for triangle PWM output function

Table 13-106 Operating Procedure for Triangle PWM Output Function

	Operation	TAUBn Status
Initial Channel Setting	<p>Master channels: Set TAUBnCMORm/TAUBnCMURm register and the channel output mode as described in (4) Register settings for master channels.</p> <p>Slave channels: Set TAUBnCMORm/TAUBnCMURm register and the channel output mode as described in (5) Register settings for slave channels</p> <p>Set the value of TAUBnCDRm register of every channel.</p>	Channel operation is stopped.
Start Operation	Set TAUBnTS.TAUBnTSm of master and slave channels to 1 simultaneously. TAUBnTS.TAUBnTSm is a trigger bit, which is automatically cleared to 0.	TAUBnTE.TAUBnTEm (master and slave channels) is set to 1 and the counter of master/slave channel starts. INTTAUBnIm (master) is generated on the master channel if TAUBnCMORm.TAUBnMD0 is set to 1.
During Operation	<p>TAUBnCDRm can be changed at any time. TAUBnCNTm and TAUBnRSF.TAUBnRSFm can be read at any time.</p> <p>TAUBnRDT.TAUBnRDTm can be changed during operation.</p>	<p>TAUBnCDRm value of master and slave channels is loaded into TAUBnCNTm to perform counting down. When the counter of master channel reaches 0000_H:</p> <ul style="list-style-type: none"> • INTTAUBnIm (master) is generated. • TAUBnTTOUTm (master) is toggled. • TAUBnCDRm value is reloaded into TAUBnCNTm (master) to continue count operation. • TAUBnCDRm value is reloaded into TAUBnCNTm (slave) or counting is started in opposite direction. <p>When TAUBnCNTm of slave channel reaches 0001_H:</p> <ul style="list-style-type: none"> • INTTAUBnIm (slave) is generated. • TAUBnTTOUTm (slave) is set in the count-down status or reset in count-up status.
Stop Operation	Set TAUBnTT.TAUBnTTm of master and slave channels to 1 simultaneously TAUBnTT.TAUBnTTm is a trigger bit, which is automatically cleared to 0.	TAUBnTE.TAUBnTEm is cleared to 0 and the counter stops. TAUBnCNTm and TAUBnTTOUTm stop and retain their current values.

Restart

(7) Specific timing diagrams**(a) Duty cycle = 0%**

The following settings apply to the general timing diagram.

- Master channels:
 - INTTAUBnIm is generated at the beginning of operation (TAUBnCMORm.TAUBnMD0 = 1).
 - TAUBnCDRm = a = 5H
- Slave channels:
 - TAUBnCDRm = 6H

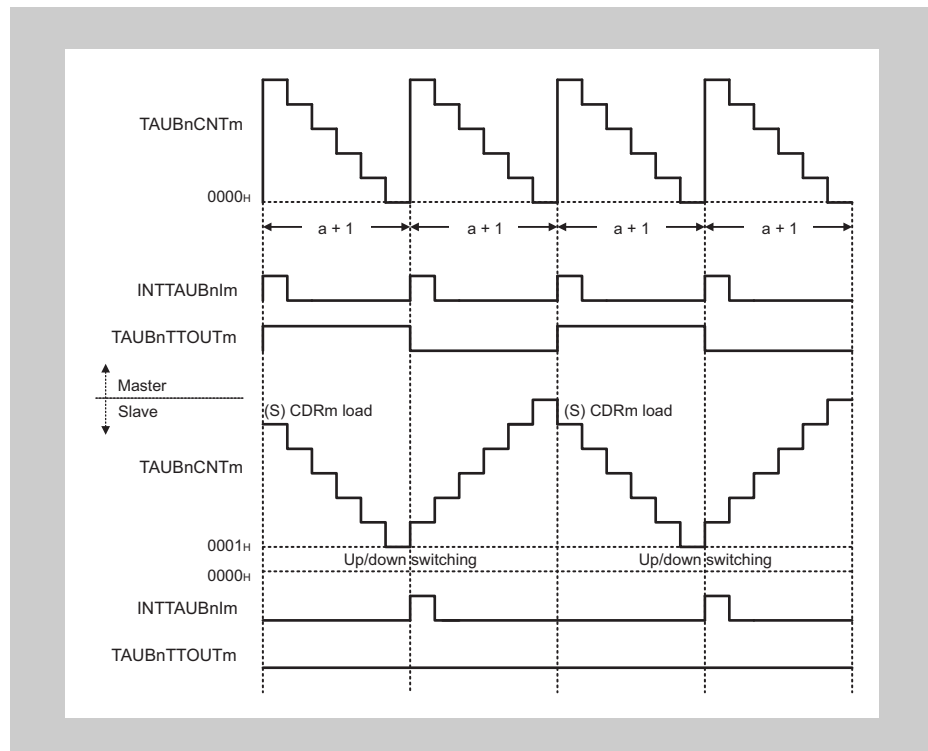

Figure 13-81 TAUBnCDRm (Slave) ≥ TAUBnCDRm (Master) + 1

- If TAUBnCDRm (slave) value is greater than TAUBnCDRm (master) value, INTTAUBnIm is not generated while the counter of slave channel is counting down. TAUBnTTOUTm remains at the inactive level because there is no set signal of TAUBnTTOUTm to be detected.

(b) Duty cycle = 100%

The following settings apply to the general timing diagram.

- Master channels:
 - INTTAUBnIm is generated at the beginning of operation (TAUBnCMORm.TAUBnMD0 = 1)
 - TAUBnCDRm = a = 5_H
- Slave channels:
 - TAUBnCDRm = 0_H

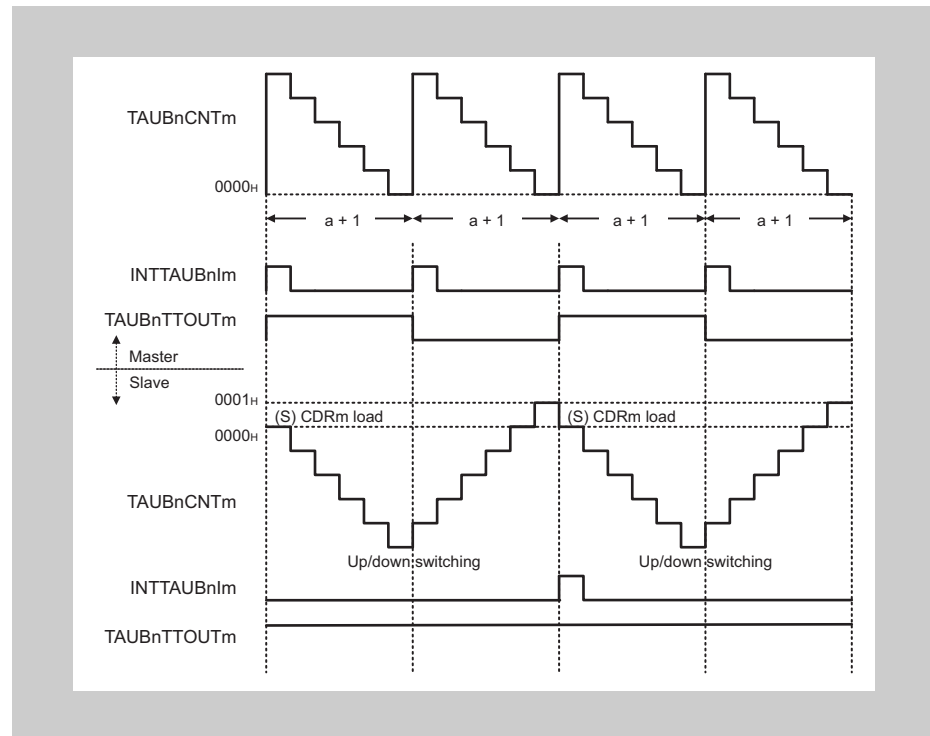

Figure 13-82 TAUBnCDRm (Slave) = 0000_H

- If TAUBnCDRm (slave) = 0000_H, INTTAUBnIm is not generated while the counter of slave channel is counting up. TAUBnTTOUTm remains at the active level because there is no reset signal of TAUBnTTOUTm to be detected.

13.20.2 Triangle PWM Output Function with Dead Time

(1) Overview

Summary This function generates multiple triangle PWM outputs with a predefined dead time added by using a master and two or more slave channels. The resulting PWM signals are output via TAUBnTTOUTm of the slave channel 3, enabling the pulse cycle (frequency) and the duty cycle of TAUBnTTOUTm to be set using the master and slave channels.

Carrier cycles are generated on master channel. The first pulse controls the down status of slave counter and the second one controls the up status.

An interrupt on slave 2 causes TAUBnTTOUTm of slave channels to be set/reset. Depending on the settings of TAUBnTDL.TAUBnTDLm, delay time is added to positive or negative logic side of the signal (i.e., whether TAUBnTTOUTm is set/reset immediately or after dead time has elapsed). The duration of the dead time is specified by slave channel 3.

- Prerequisites**
- Three channels. For slave channels 2 and 3, select even channel CH (a) and odd channel CH (a + 1).
 - The operating mode for master channels should be set to interval timer mode. (See Table 13-108, TAUBnCMORm Settings for Master Channels of Triangle PWM Output Function with Dead Time.)
 - Slave channel 1 is not used for this function. Be sure to select an even channel for slave channel 2 and an odd channel for slave channel 3.
 - The operating mode for slave channel 2 should be set to up/down count mode. (See Table 13-112, TAUBnCMORm Settings for Slave Channel 2 of Triangle PWM Output Function with Dead Time.) Slave channel 2 should be an even channel.
 - The operating mode for slave channel 3 should be set to one-count mode. (See Table 13-116, TAUBnCMORm Settings for Slave Channel 3 of Triangle PWM Output Function with Dead Time.) Slave channel 3 should be an odd channel.
 - The channel output mode for master channels should be set to independent channel output mode 1. (See Section 13.8, Channel Output Modes.)
 - The output mode for slave channels 2 and 3 should be set to synchronous channel output mode 2 with dead time output. (See Section 13.8, Channel Output Modes.)
 - The following settings make a TAUBnTTOUTm signal at high level during the down status of the carrier cycle:
 - If TAUBnCMORm.TAUBnMD0 (master) bit is set to 0, TAUBnTO.TAUBnTOm should be set to 1 while TAUBnTOE.TAUBnTOEm is set to 0. (recommended setting)
 - If TAUBnCMORm.TAUBnMD0 (master) bit is set to 1, TAUBnTO.TAUBnTOm should be set to 0 while TAUBnTOE.TAUBnTOEm is set to 0.

Note The triangle PWM output function with dead time does not use slave channel 1.

Description The counter starts by setting the channel trigger bit (TAUBnTS.TAUBnTsm) to 1. This makes TAUBnTE.TAUBnTEm = 1, enabling count operation. The current value of TAUBnCDRm is loaded into TAUBnCNTm and the counter starts to count down from the TAUBnCDRm value. If TAUBnCMORm.TAUBnMD0 bit of master channel is set to 1, an interrupt is generated and the master's TAUBnTTOUTm signal is toggled.

- Master channels:

When the counter of master channel reaches 0000_H, an INTTAUBnIm is generated and the TAUBnTTOUTm signal is toggled. The TAUBnCDRm value is reloaded to continue countdown.

- Slave channel 2:

If INTTAUBnIm is generated on the master channel, the counter of slave channel 2 is triggered.

- If the slave counter is counting down, the counting direction changes.
- If the slave counter is counting up, the TAUBnCDRm value is reloaded and the counter starts to count down.

The counter continues to count down/up and waits for the next INTTAUBnIm of master channel.

- Slave channel 3:

If INTTAUBnIm is generated on slave channel 2, the counter of slave channel 3 is triggered. The current value of TAUBnCDRm (slave 3) is loaded into TAUBnCNTm (slave 3) and the counter starts to count down from the TAUBnCDRm value.

When the counter reaches 0000_H, INTTAUBnIm occurs. The counter returns to FFFF_H and waits for the next INTTAUBnIm of slave channel 2.

As described in Table 13-107, Operation of TAUBnTTOUTm upon Occurrence of an Interrupt on Slave Channel 2, the set/reset timing (right after occurrence of an interrupt or after dead time has elapsed) depends on the TAUBnTDL.TAUBnTDLm setting of the corresponding channel.

The setting of TAUBnTOL.TAUBnTOLm also determines whether a high level signal (TAUBnTOL.TAUBnTOLm = 0) or a low level signal (TAUBnTOL.TAUBnTOLm = 1) is output from the corresponding channel.

The counter can be stopped by setting TAUBnTT.TAUBnTTm of master and slave channels to 1. This sets TAUBnTE.TAUBnTEm to 0. TAUBnCNTm and TAUBnTTOUTm of master and slave channels stop but retain their values.

TAUBnTTOUTm can be 100 % output by setting the TAUBnCDRm value of slave channel 2 to 0000_H.

Note If a forced restart is executed during operation, TAUBnTTOUTm is not output as a triangle PWM signal.

Conditions This function enables simultaneous rewrite. See Section 13.7, Simultaneous Rewrite.

TAUBnTOL.TAUBnTOLm and TAUBnTDL.TAUBnTDLm should be set before start of count operation. Slave channels 2 and 3 should have the opposite settings of TAUBnTOL.TAUBnTOLm or TAUBnTDL.TAUBnTDLm.

Table 13-107 Operation of TAUBnTTOUTm upon Occurrence of an Interrupt on Slave Channel 2

TAUBnTDL. TAUBnTDLm	Count Direction of Slave Channel 2 upon Occurrence of Interrupt	TAUBnTTOUTm Set/Reset Timing
0	Down	Set after elapse of dead time
	Up	Reset right after interrupt occurs
1	Down	Set right after interrupt occurs
	Up	Reset after elapse of dead time

(2) Equations

Pulse cycle = (TAUBnCDRm (master) + 1) × count clock cycle

$0000_H \leq \text{TAUBnCDRm (master)} < \text{FFFF}_H$

Carrier cycle (down/up) = (TAUBnCDRm (master) + 1) × 2 × count clock cycle

PWM signal width (normal phase) = [(TAUBnCDRm (master) + 1 -
TAUBnCDRm (slave 2)) × 2 - (TAUBnCDRm (slave 3) + 1)] × count clock cycle

PWM signal width (reverse phase) = [(TAUBnCDRm (master) + 1 -
TAUBnCDRm (slave 2)) × 2 + (TAUBnCDRm (slave 3) + 1)] × count clock
cycle

(3) Block diagram and general timing diagram

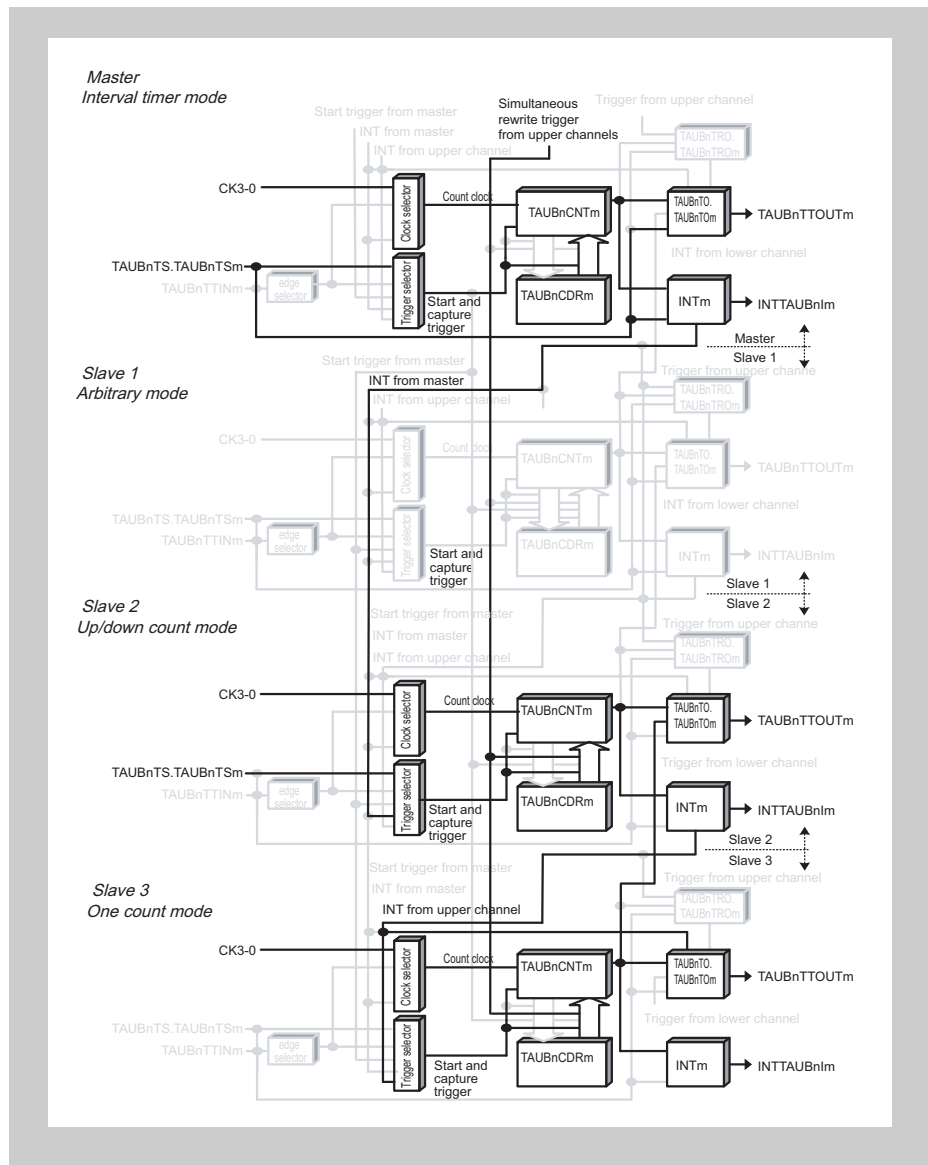

Figure 13-83 Block Diagram of Triangle PWM Output Function with Dead Time

The following settings apply to the general timing diagram.

- Master channels:
 - INTTAUBnIm is generated at the beginning of operation.
(TAUBnCMORm.TAUBnMD0 = 1)
- Slave channel 2:
 - INTTAUBnIm is not generated at the beginning of operation.
(TAUBnCMORm.TAUBnMD0 = 0)
 - TAUBnTDL.TAUBnTDLm = 0
 - Positive logic (TAUBnTOL.TAUBnTOLm = 0)
- Slave channel 3:
 - INTTAUBnIm is generated at the beginning of operation.
(TAUBnCMORm.TAUBnMD0 = 1)
 - TAUBnTDL.TAUBnTDLm = 1
 - Negative logic (TAUBnTOL.TAUBnTOLm = 1)

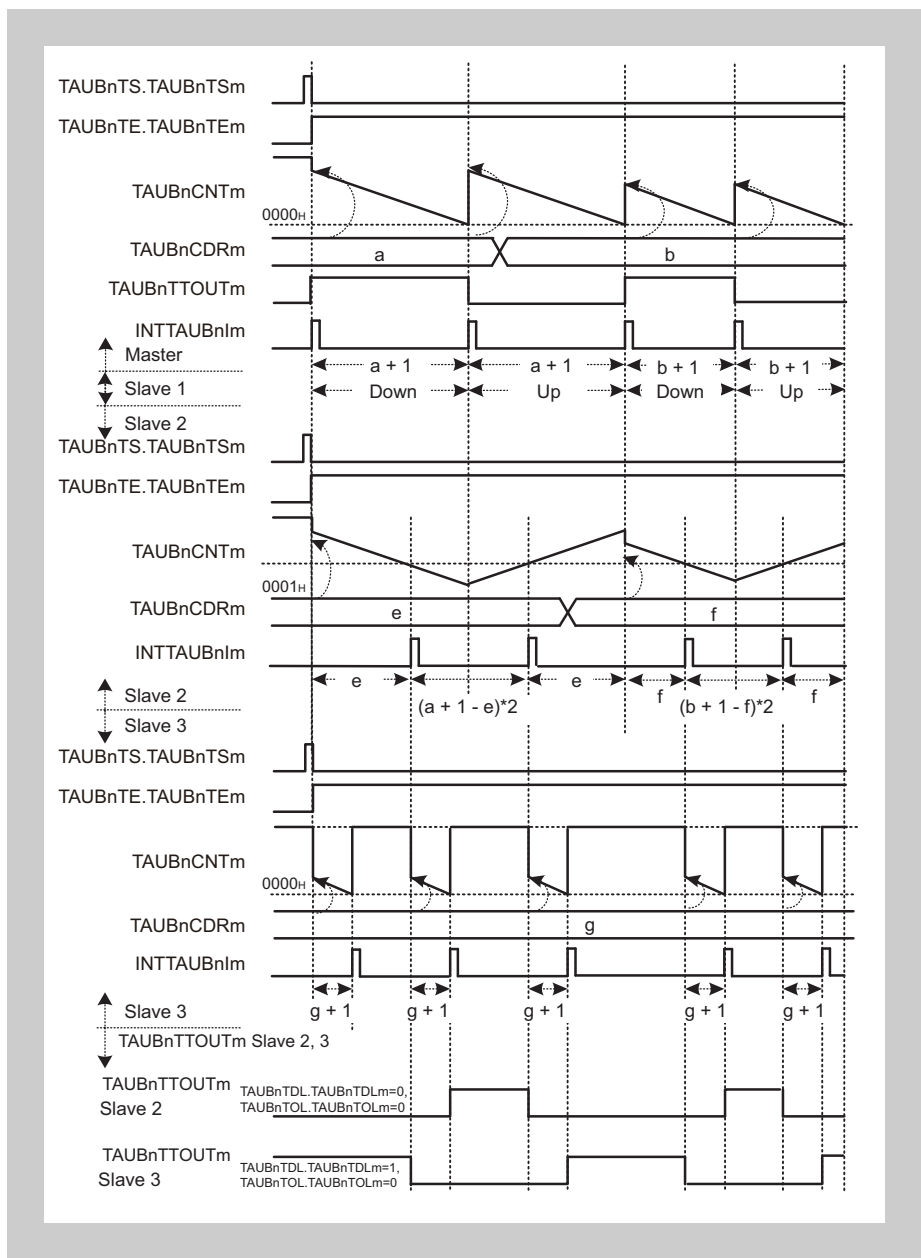

Figure 13-84 General Timing Diagram of Triangle PWM Output Function with Dead Time

(4) Register settings for master channels

(a) TAUBnCMORm for master channels

15	14	13	12	11	10	9	8	7	6	5	4	3	2	1	0
TAUBnCKS [1:0]	TAUBnCCS [1:0]	TAUBnMAS	TAUBnSTS[2:0]			TAUBnCOS [1:0]		-	TAUBnMD[4:1]				TAUBnMD0		

Table 13-108 TAUBnCMORm Settings for Master Channels of Triangle PWM Output Function with Dead Time

Bit Name	Setting
TAUBnCKS[1:0]	00: Prescaler output CK0 01: Prescaler output CK1 10: Prescaler output CK2 11: Prescaler output CK3 TAUBnCKS[1:0] bits of master and slave channels should have the same value.
TAUBnCCS[1:0]	00: Uses an operation clock as a count clock.
TAUBnMAS	1: Master channel
TAUBnSTS[2:0]	000: Triggers the counter by software.
TAUBnCOS[1:0]	00: Unused. Set to 00.
TAUBnMD[4:1]	0000: Interval timer mode
TAUBnMD0	0: INTTAUBnIm is not generated and TAUBnTTOUTm is not toggled at the beginning of operation. 1: INTTAUBnIm is generated and TAUBnTTOUTm is toggled at the beginning of operation.

(b) TAUBnCMURm for master channels

7	6	5	4	3	2	1	0
-						TAUBnTIS[1:0]	

Table 13-109 TAUBnCMURm Settings for Master Channels of Triangle PWM Output Function with Dead Time

Bit Name	Setting
TAUBnTIS[1:0]	00: Unused. Set to 00.

(c) Channel output mode for master channels**Table 13-110 Control Bit Settings in Independent Channel Output Mode 1**

Bit Name	Setting
TAUBnTOE.TAUBnTOEm	1: Enables independent channel output mode.
TAUBnTOM.TAUBnTOMm	0: Independent channel output
TAUBnTOC.TAUBnTOCm	0: Operating mode 1 (toggle mode when TAUBnTOM.TAUBnTOMm = 0)
TAUBnTOL.TAUBnTOLm	0: Positive logic
TAUBnTDE.TAUBnTDEm	0: Disables dead time operation.
TAUBnTDL.TAUBnTDLm	0: When disabling dead time operation (TAUBnTDE.TAUBnTDEm = 0), set these bits to 0.

(d) Simultaneous rewrite for master channels

Both master and slave channels should have the same simultaneous rewrite settings.

Table 13-111 Simultaneous Rewrite for Master Channels of Triangle PWM Output Function with Dead Time

Bit Name	Setting
TAUBnRDE.TAUBnRDEm	1: Enables simultaneous rewrite.
TAUBnRDS.TAUBnRDSm	0: Monitors master channels for simultaneous rewrite triggers. 1: Monitors upper channels other than the channel group for simultaneous rewrite triggers.
TAUBnRDM.TAUBnRDMm	1: Simultaneous rewrite trigger signal is generated when master channel counter is started and the corresponding master channel is at the peak of triangular wave cycle.
TAUBnRDC.TAUBnRDCm	0: Channel is not monitored for INTTAUBnIm signals used as simultaneous rewrite triggers. When TAUBnRDS.TAUBnRDSm = 0, the master channel is monitored for simultaneous rewrite triggers regardless of the value of this bit.

Note If TAUBnRDS.TAUBnRDSm = 1, it is necessary for an upper channel higher than a master channel to generate a simultaneous rewrite trigger signal.

(5) Register settings for slave channel 2**(a) TAUBnCMORm for slave channel 2**

15	14	13	12	11	10	9	8	7	6	5	4	3	2	1	0
TAUBnCKS [1:0]	TAUBnCCS [1:0]	TAUB nMAS	TAUBnSTS[2:0]		TAUBnCOS [1:0]	-		TAUBnMD[4:1]				TAUBn MD0			

Table 13-112 TAUBnCMORm Settings for Slave Channel 2 of Triangle PWM Output Function with Dead Time

Bit Name	Setting
TAUBnCKS[1:0]	00: Prescaler output CK0 01: Prescaler output CK1 10: Prescaler output CK2 11: Prescaler output CK3 TAUBnCKS[1:0] bits of master and slave channels should have the same value.
TAUBnCCS[1:0]	00: Uses an operation clock as a count clock.
TAUBnMAS	0: Slave channel
TAUBnSTS[2:0]	111: Up/down output trigger signal of master channel
TAUBnCOS[1:0]	00: Unused. Set to 00.
TAUBnMD[4:1]	1001: Up/down count mode
TAUBnMD0	0: INTTAUBnIm is not generated at the beginning of operation.

(b) TAUBnCMURm for slave channel 2

7	6	5	4	3	2	1	0
-							TAUBnTIS[1:0]

Table 13-113 TAUBnCMURm Settings for Slave Channel 2 of Triangle PWM Output Function with Dead Time

Bit Name	Setting
TAUBnTIS[1:0]	00: Unused. Set to 00.

(c) Channel output mode for slave channel 2**Table 13-114 Control Bit Settings in Synchronous Channel Output Mode 2 with Dead Time**

Bit Name	Setting
TAUBnTOE.TAUBnTOEm	1: Enables independent channel output mode.
TAUBnTOM.TAUBnTOMm	1: Synchronous channel operation
TAUBnTOC.TAUBnTOCm	1: Operating mode 2
TAUBnTOL.TAUBnTOLm	0: Positive logic 1: Inverted logic
TAUBnTDE.TAUBnTDEm	1: Enables dead time operation.
TAUBnTDL.TAUBnTDLm	0: Adds dead time to normal phase. 1: Adds dead time to reverse phase.

Caution Set TAUBnTDLm exclusively from odd channels.

(d) Simultaneous rewrite for slave channel 2

Both master and slave channels should have the same simultaneous rewrite settings.

Table 13-115 Simultaneous Rewrite Settings for Slave Channel 2 of Triangle PWM Output Function

Bit Name	Setting
TAUBnRDE.TAUBnRDEm	1: Enables simultaneous rewrite.
TAUBnRDS.TAUBnRDSm	0: Monitors master channels for simultaneous rewrite triggers. 1: Monitors upper channels other than the channel group for simultaneous rewrite triggers.
TAUBnRDM.TAUBnRDMm	1: Simultaneous rewrite trigger signal is generated when master channel counter is started and the corresponding master channel is at the peak of triangular wave cycle.
TAUBnRDC.TAUBnRDCm	0: Channel is not monitored for INTTAUBnIm signals used as simultaneous rewrite triggers. When TAUBnRDS.TAUBnRDSm = 0, the master channel is monitored for simultaneous rewrite triggers regardless of the value of this bit.

(6) Register settings for slave channel 3

(a) TAUBnCMORm for slave channel 3

15	14	13	12	11	10	9	8	7	6	5	4	3	2	1	0
TAUBnCKS [1:0]	TAUBnCCS [1:0]	TAUBnMAS	TAUBnSTS[2:0]			TAUBnCOS [1:0]		-	TAUBnMD[4:1]				TAUBnMD0		

Table 13-116 TAUBnCMORm Settings for Slave Channel 3 of Triangle PWM Output Function with Dead Time

Bit Name	Setting
TAUBnCKS[1:0]	00: Prescaler output CK0 01: Prescaler output CK1 10: Prescaler output CK2 11: Prescaler output CK3 TAUBnCKS[1:0] bits of master and slave channels should have the same value.
TAUBnCCS[1:0]	00: Uses an operation clock as a count clock.
TAUBnMAS	0: Slave channel
TAUBnSTS[2:0]	110: Dead time trigger
TAUBnCOS[1:0]	00: Unused. Set to 00.
TAUBnMD[4:1]	0100: One-count mode
TAUBnMD0	1: Enables start trigger detection during counting.

(b) TAUBnCMURm for slave channel 3

7	6	5	4	3	2	1	0
-						TAUBnTIS[1:0]	

Table 13-117 TAUBnCMURm Settings for Slave Channel 3 of Triangle PWM Output Function with Dead Time

Bit Name	Setting
TAUBnTIS[1:0]	00: Unused. Set to 00.

(c) Channel output mode for slave channel 3**Table 13-118 Control Bit Settings in Synchronous Channel Output Mode 2 with Dead Time Output**

Bit Name	Setting
TAUBnTOE.TAUBnTOEm	1: Enables independent channel output mode.
TAUBnTOM.TAUBnTOMm	1: Synchronous channel operation
TAUBnTOC.TAUBnTOCm	1: Operating mode 2
TAUBnTOL.TAUBnTOLm	0: Positive logic 1: Inverted logic
TAUBnTDE.TAUBnTDEm	1: Enables dead time operation.
TAUBnTDL.TAUBnTDLm	0: Adds dead time to normal phase. 1: Adds dead time to reverse phase.

Caution Set TAUBnTDL.TAUBnTDLm exclusively from even channels.

(d) Simultaneous rewrite for slave channel 3

Both master and slave channels should have the same simultaneous rewrite settings.

Table 13-119 Simultaneous Rewrite Settings for Slave Channel 3 of Triangle PWM Output Function

Bit Name	Setting
TAUBnRDE.TAUBnRDEm	1: Enables simultaneous rewrite.
TAUBnRDS.TAUBnRDSm	0: Monitors master channels for simultaneous rewrite triggers. 1: Monitors upper channels other than the channel group for simultaneous rewrite triggers.
TAUBnRDM.TAUBnRDMm	1: Simultaneous rewrite trigger signal is generated when master channel counter is started and the corresponding master channel is at the peak of triangular wave cycle.
TAUBnRDC.TAUBnRDCm	0: Channel is not monitored for INTTAUBnIm signals used as simultaneous rewrite triggers. When TAUBnRDS.TAUBnRDSm = 0, the master channel is monitored for simultaneous rewrite triggers regardless of the value of this bit.

(7) Operating procedure for triangle PWM output function with dead time

Table 13-120 Operating Procedure for Triangle PWM Output Function with Dead Time

	Operation	TAUBn Status
Restart	<p>Initial Channel Setting</p> <p>Master channels: Set TAUBnCMORm/TAUBnCMURm register and the channel output mode as described in (4) Register settings for master channels.</p> <p>Slave channel 2: Set TAUBnCMORm/TAUBnCMURm register and the channel output mode as described in (5) Register settings for slave channel 2.</p> <p>Slave channel 3: Set TAUBnCMORm/TAUBnCMURm register and the channel output mode as described in (6) Register settings for slave channel 3.</p> <p>Set the value of TAUBnCDRm register of every channel.</p>	Channel operation is stopped.
	<p>Start Operation</p> <p>Set TAUBnTS.TAUBnTSM of master and slave channels to 1 simultaneously. TAUBnTS.TAUBnTSM is a trigger bit, which is automatically cleared to 0.</p>	TAUBnTE.TAUBnTEm (master and slave channels) is set to 1 and the counter of master/slave channel starts. INTTAUBnIm (master) is generated on the master channel if TAUBnCMORm.TAUBnMD0 is set to 1.
	<p>During Operation</p> <p>TAUBnCDRm can be changed at any time. TAUBnCNTm and TAUBnRSF.TAUBnRSFm can be read at any time.</p> <p>TAUBnRDT.TAUBnRDTm can be changed during operation.</p>	<p>TAUBnCDRm value of master channel and slave channel 2 is loaded into TAUBnCNTm to perform counting down. When the counter of master channel reaches 0000_H:</p> <ul style="list-style-type: none"> • INTTAUBnIm (master) is generated. • TAUBnCDRm value is reloaded into TAUBnCNTm (master) to continue count operation. • TAUBnCDRm value is reloaded into TAUBnCNTm (slave 2) or counting is started in opposite direction. <p>When TAUBnCNTm of slave channel 2 reaches 0001_H:</p> <ul style="list-style-type: none"> • INTTAUBnIm (slave 2) is generated. • TAUBnCDRm value of slave channel 3 is loaded into TAUBnCNTm perform counting down. <p>When TAUBnCNTm of slave channel 3 reaches 0000_H:</p> <ul style="list-style-type: none"> • INTTAUBnIm is generated.
	<p>Stop Operation</p> <p>Set TAUBnTT.TAUBnTTm of master and slave channels to 1 simultaneously. TAUBnTT.TAUBnTTm is a trigger bit, which is automatically cleared to 0.</p>	TAUBnTE.TAUBnTEm is cleared to 0 and the counter stops. TAUBnCNTm and TAUBnTTOUm stop and retain their current values.

(8) Specific timing diagrams

(a) Duty cycle = 0%

The following settings apply to the general timing diagram.

- Slave channel 2:
 - Positive logic (TAUBnTDL.TAUBnTDLm = 0)
- Slave channel 3:
 - Negative logic (TAUBnTDL.TAUBnTDLm = 1)

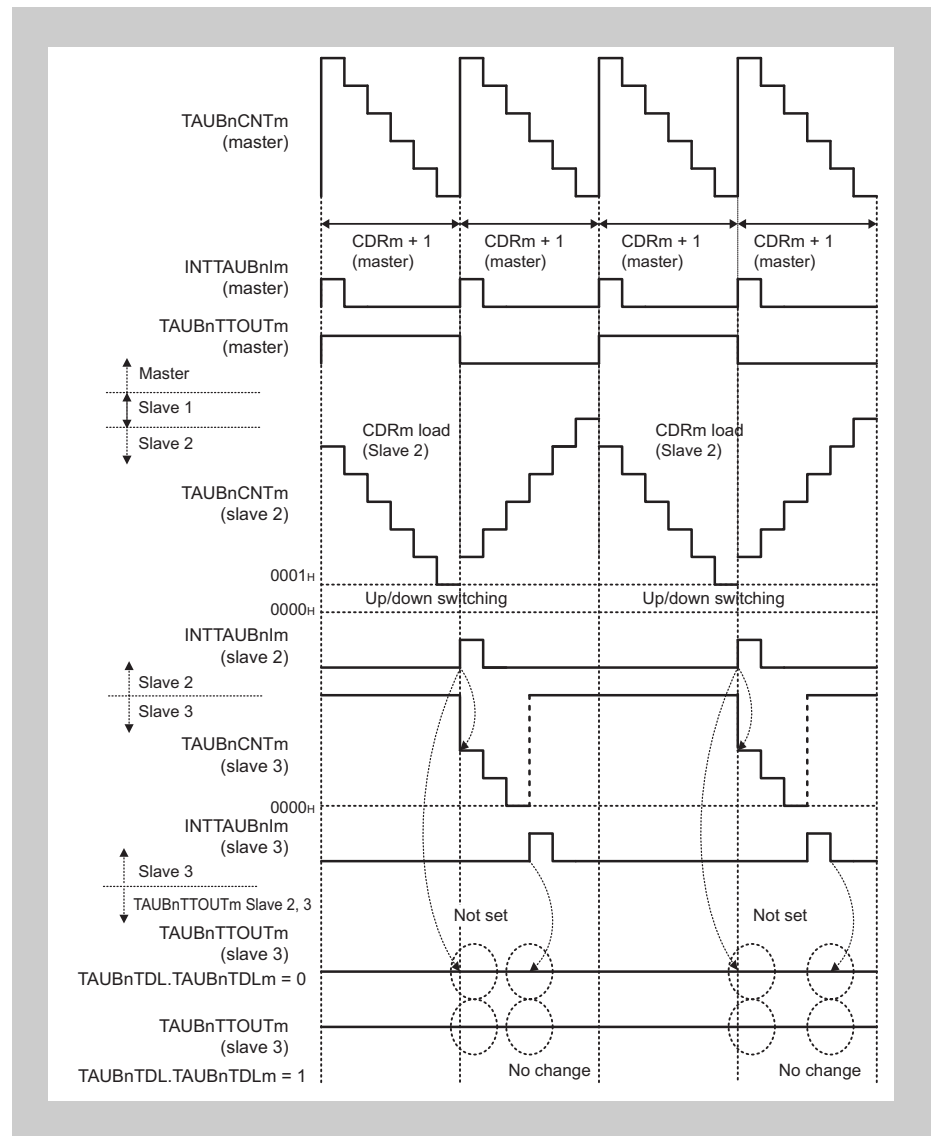

Figure 13-85 TAUBnCDRm (Slave 2) ≥ TAUBnCDRm (Master) + 1

- If TAUBnCDRm (slave 2) is greater than TAUBnCDRm (master), INTTAUBnIm is not generated while the counter of slave channel 2 or 3 is counting down. TAUBnTTOUm remains at the inactive level because there is no set signal of TAUBnTTOUm to be detected.

(b) Duty cycle = 100%

The following settings apply to the general timing diagram.

- Slave channel 2:
 - Positive logic (TAUBnTDL.TAUBnTDLm = 0)
- Slave channel 3:
 - Negative logic (TAUBnTDL.TAUBnTDLm = 1)

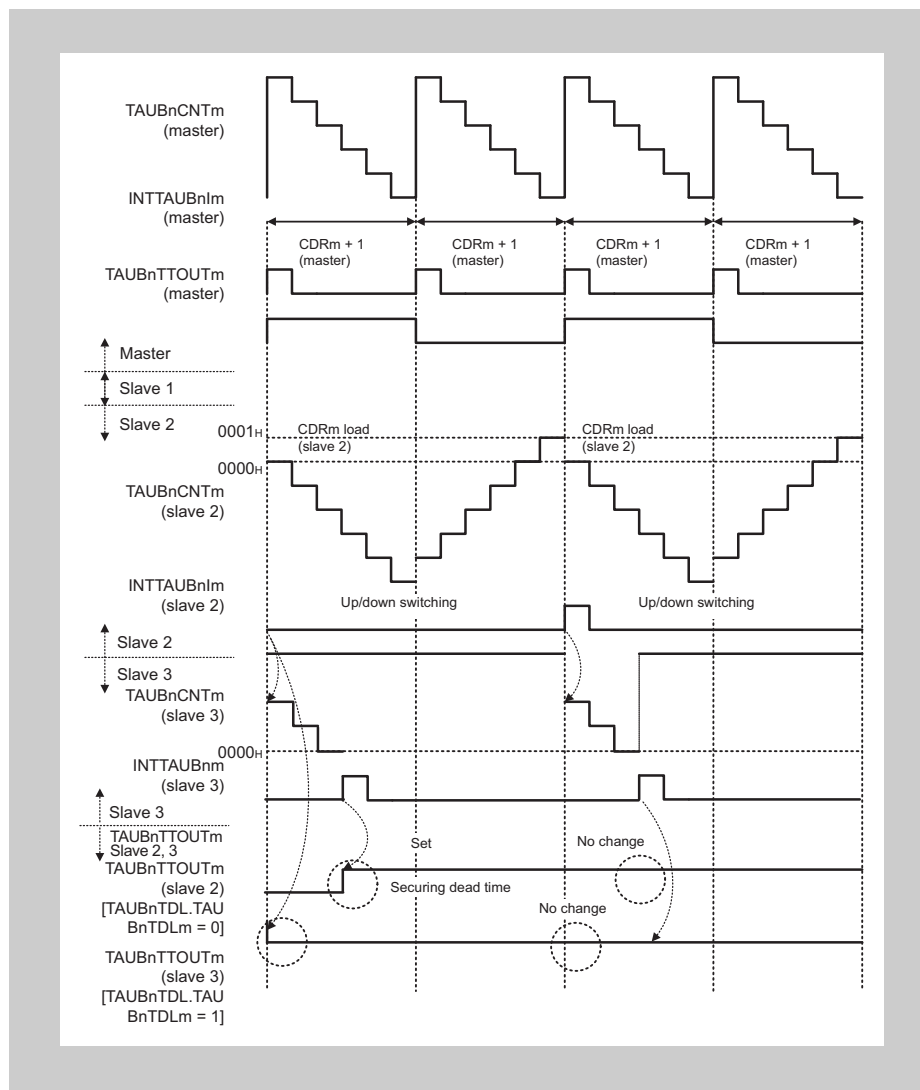

Figure 13-86 TAUBnCDRm (Slave 2) = 0000_H

- If TAUBnCDRm (slave 2) = 0000_H, INTTAUBnIm is not generated while the counter of slave channel is counting up. TAUBnTTOUTm remains at the active level because there is no reset signal of TAUBnTTOUTm to be detected. After setting TAUBnTS.TAUBnTSm = 1, inverse phase output of TAUBnTTOUTm is forcibly set and remains at the active level thereafter; positive phase output is set after securing dead time and remains at the active level thereafter.
 - The set conditions for a channel with TAUBnTDL.TAUBnTDLm = 0 are met after elapse of dead time. TAUBnTTOUTm is left in a newly set state even if a set/reset is made because no reset conditions are satisfied on such a channel.
 - Slave channel 3 in the above diagram is set when the counter starts. However, TAUBnTTOUTm is left in an initial state on the slave channel with TAUBnTDL.TDLm = 1 because no reset conditions are satisfied on that channel.

(c)TAUBnTTOUTm (slave 2) = 0 % and TAUBnTTOUTm (slave 3) > 0 %

The following settings apply to the diagram below:

- Slave channel 2:
 - Positive logic (TAUBnTOL.TOLm = 0)
- Slave channel 3:
 - Negative logic (TAUBnTOL.TOLm = 1)

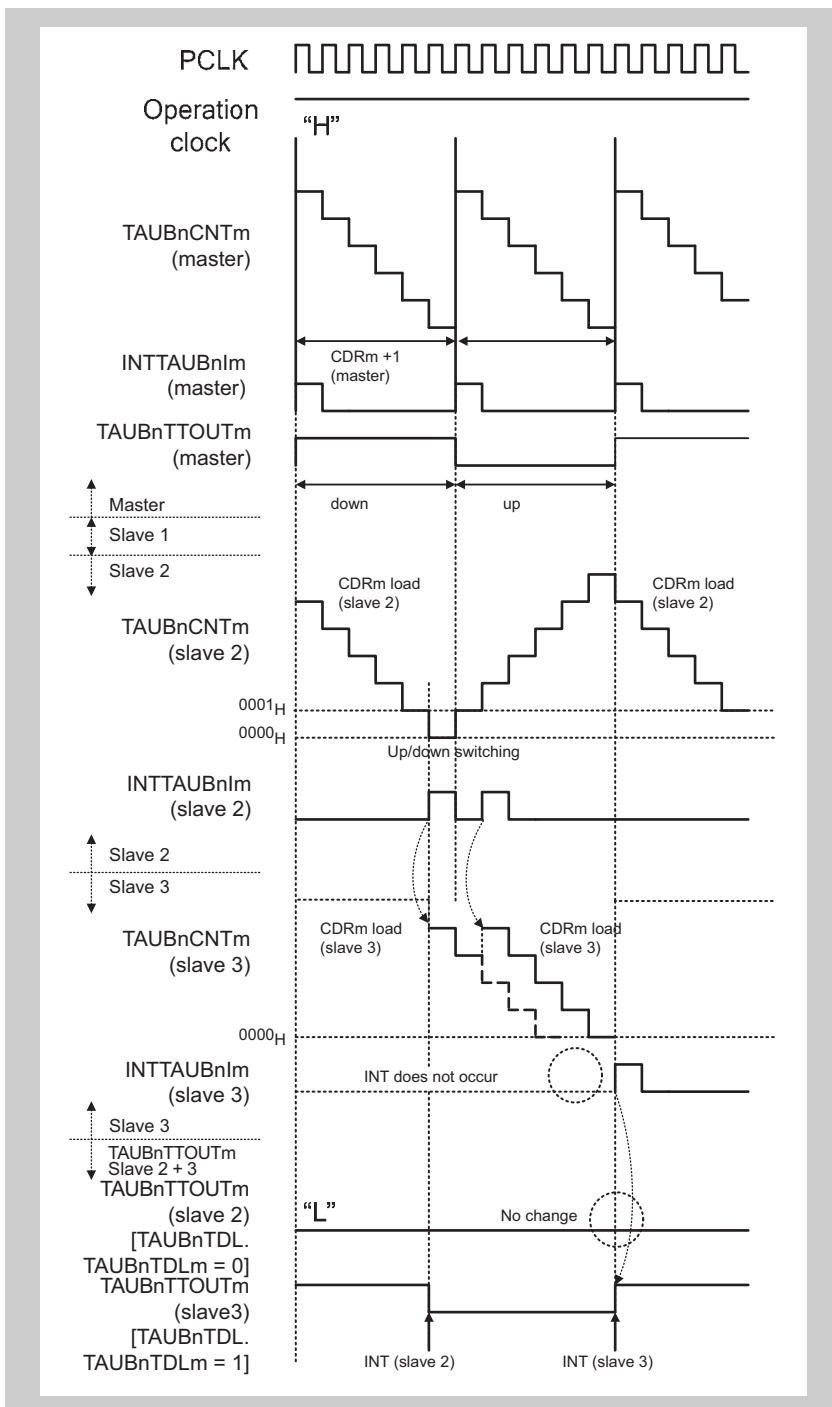

Figure 13-87 TAUBnCDRm (master) = 0005H, TAUBnCDRm (slave 2) = 0005H, TAUBnCDRm (slave 3) = 0004H

- When the counter of slave channel 2 reaches 0000_H , INTTAUBnIm (slave 2) is generated. The counter of slave channel 3 starts to count down.
- If another INTTAUBnIm (slave 2) is generated while the counter of slave channel 3 is still counting down, the value of TAUBnCDRm (slave 3) is reloaded and the counter restarts counting down from this value.
- In the diagram above, the first interrupt on channel 2 occurs while the counter is counting down, and the second whilst it is counting up.
- After the first interrupt, a slave for which TAUBnTDL.TDLm = 0 waits for dead time to elapse before setting. However, before the dead time has elapsed, another interrupt occurs on slave 2, this time while the counter is counting up. This acts as a reset signal, meaning that a channel for which TAUBnTDL.TDLm = 0 always remains inactive.
- TAUBnTTOUTm of a slave channel for which TAUBnTDL.TDLm = 1 is set and reset as normal when the corresponding INTTAUBnIm is generated.

(d)TAUBnTTOUTm (slave 2) > 0 % and TAUBnTTOUTm (slave 3) = 100 %

The following settings apply to the diagram below:

- Slave channel 2:
 - Positive logic (TAUBnTOL.TOLm = 0)
- Slave channel 3:
 - Negative logic (TAUBnTOL.TOLm = 1)

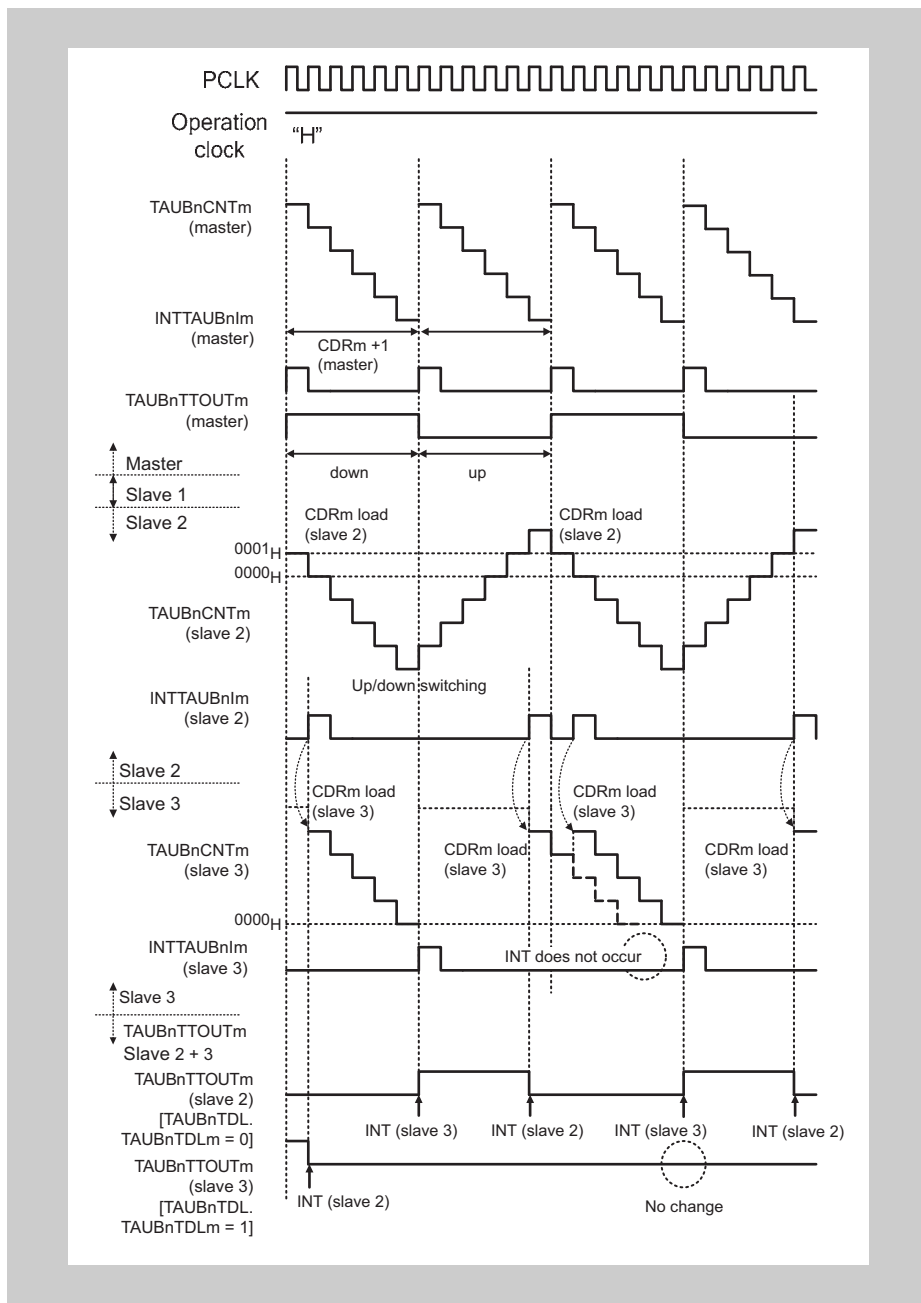

Figure 13-88 TAUBnCDRm (master) = 0005_H, TAUBnCDRm (slave 2) = 0002_H, TAUBnCDRm (slave 3) = 0004_H
 PWM signal width (negative phase) ≥ Carrier cycle

- After the second interrupt, a slave for which TAUBnTDL.TDLm = 1 waits for dead time to elapse before resetting. However, before the dead time has elapsed, another interrupt occurs on slave 2, this time while the counter is counting up. This acts as a set signal, meaning that a channel for which TAUBnTDL.TDLm = 1 always remains active.
- TAUBnTTOUTm of a slave channel for which TAUBnTDL.TDLm = 0 is set and reset as normal when the corresponding INTTAUBnIm is generated.

(e) Inhibited INTTAUBnIm to set TAUBnTTOUTm positive phase period

The following settings apply to the diagram below:

- Slave channel 2:
 - Positive logic (TAUBnTOL.TOLm = 0)
- Slave channel 3:
 - Negative logic (TAUBnTOL.TOLm = 1)

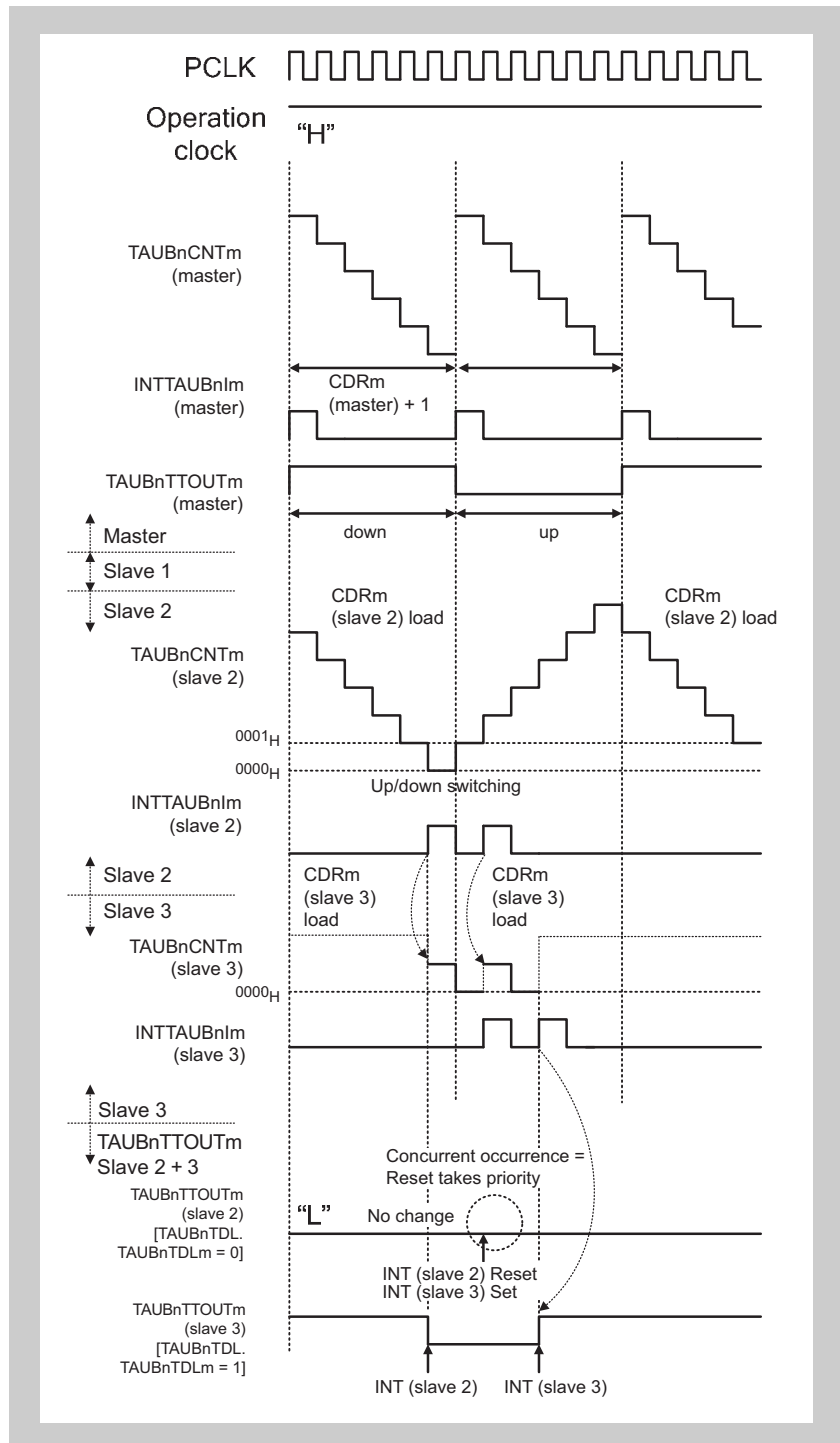

**Figure 13-89 TAUBnCDRm (master) = 0005_H, TAUBnCDRm (slave 2) = 0005_H,
TAUBnCDRm (slave 3) = 0001_H
PWM signal width (positive phase) = 0**

- The counter of slave channel 3 reaches 0000_{H} and generates an INTTAUBnIm to set the TAUBnTTOUTm of slave channel for which $\text{TAUBnTDL.TDLm} = 0$ (slave channel 2 in this example).
- If channel 2 generates an INTTAUBnIm to reset TAUBnTTOUTm simultaneously, this reset signal has priority (assuming $\text{TAUBnTOL.TOLm} = 0$, otherwise the set signal has priority).
- Therefore, TAUBnTTOUTm of a slave channel for which $\text{TAUBnTDL.TDLm} = 0$ remains in its initial state.

(f) Inhibited INTTAUBnIm to set TAUBnTTOUTm negative phase period

The following settings apply to the diagram below:

- Slave channel 2:
 - Positive logic (TAUBnTOL.TOLm = 0)
- Slave channel 3:
 - Negative logic (TAUBnTOL.TOLm = 1)

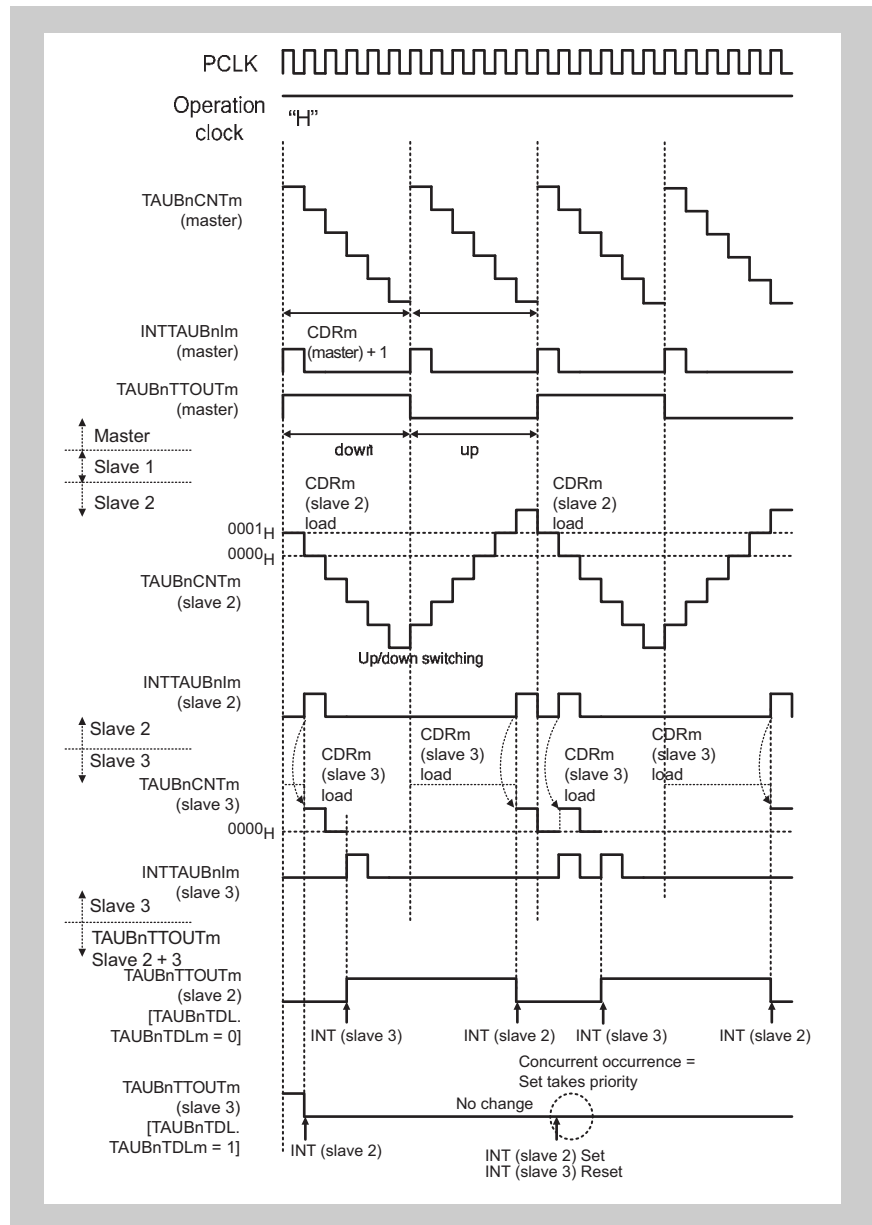

Figure 13-90 TAUBnCDRm (master) = 0005_H, TAUBnCDRm (slave 2) = 0001_H,
 TAUBnCDRm (slave 3) = 0001_H
 PWM signal width (negative phase) = carrier cycle

- The counter of slave channel 3 reaches 0000_H and generates an INTTAUBnIm to set the TAUBnTTOUTm of slave channel for which TAUBnTDL.TDLm = 1 (slave 3 in this example).
- If channel 2 generates an INTTAUBnIm to reset TAUBnTTOUTm simultaneously, the set signal has priority (assuming TAUBnTOL.TOLm = 1, otherwise the reset signal has priority).
- Therefore, TAUBnTTOUTm of slave channel for which TAUBnTDL.TDLm = 1 remains in its initial state.

13.20.3 AD Conversion Trigger Output Function Type 2

(1) Overview

Summary This function is identical to Section 13.20.1, Triangle PWM Output Function, except that TAUBnTTOUm is not output.

This function is enabled by setting channel output mode for the slave to independent channel output mode controlled by software.

(2) Block diagram and general timing diagram

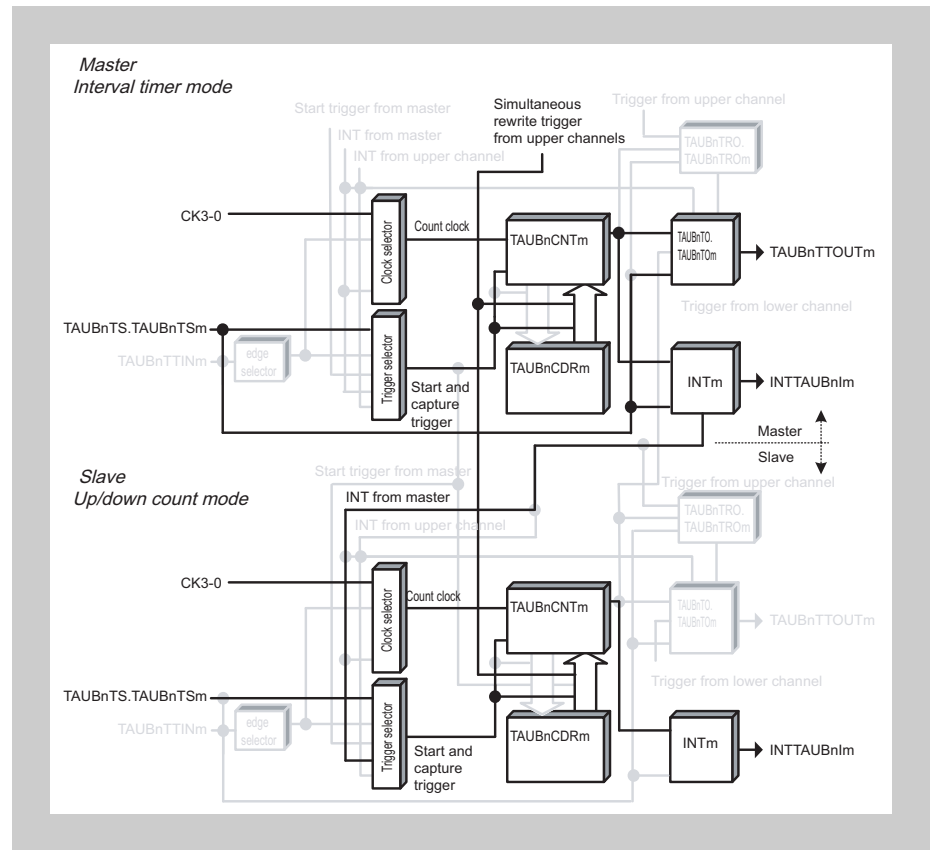

Figure 13-91 Block Diagram of AD Conversion Trigger Output Function Type 2

The following settings apply to the general timing diagram.

- Master channel
 - INTTAUBnIm is generated at the beginning of operation.
(TAUBnCMORm.TAUBnMD0 = 0)

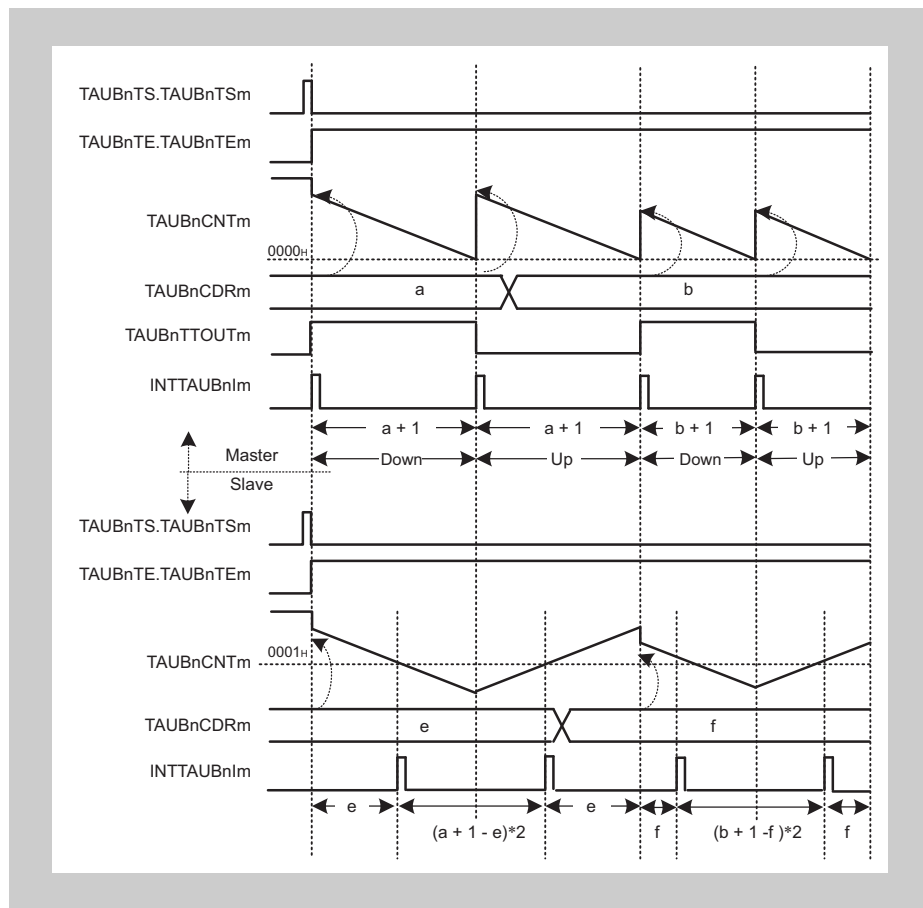

Figure 13-92 General Timing Diagram of AD Conversion Trigger Output Function Type 2

13.21 Registers

This section contains a description of all the registers of the 16-bit Timer Array Unit B.

13.21.1 Overview of TAUBn Registers

TAUBn is controlled and operated by the registers listed below. One register with one channel is indicated by “m”, which stands for 0 to 15.

Table 13-121 Overview of TAUBn Registers

Register Name	Abbreviation	Address
TAUBn prescaler registers		
TAUBn prescaler clock select register	TAUBnTPS	<TAUBn_base0> + 240 _H
TAUBn control registers		
TAUBn channel data register m	TAUBnCDRm	<TAUBn_base1> + m × 4 _H
TAUBn channel counter register m	TAUBnCNTm	<TAUBn_base1> + 80 _H + m × 4 _H
TAUBn channel mode OS register m	TAUBnCMORm	<TAUBn_base0> + 200 _H + m × 4 _H
TAUBn channel mode user register m	TAUBnCMURm	<TAUBn_base1> + C0 _H + m × 4 _H
TAUBn channel status register m	TAUBnCSRm	<TAUBn_base1> + 140 _H + m × 4 _H
TAUBn channel status clear trigger register m	TAUBnCSCm	<TAUBn_base1> + 180 _H + m × 4 _H
TAUBn channel start trigger register	TAUBnTS	<TAUBn_base1> + 1C4 _H
TAUBn channel enable status register	TAUBnTE	<TAUBn_base1> + 1C0 _H
TAUBn channel stop trigger register	TAUBnTT	<TAUBn_base1> + 1C8 _H
TAUBn output registers		
TAUBn channel output enable register	TAUBnTOE	<TAUBn_base1> + 5C _H
TAUBn channel output register	TAUBnTO	<TAUBn_base1> + 58 _H
TAUBn channel output mode register	TAUBnTOM	<TAUBn_base0> + 248 _H
TAUBn channel output configuration register	TAUBnTOC	<TAUBn_base0> + 24C _H
TAUBn channel output active level register	TAUBnTOL	<TAUBn_base1> + 040 _H
TAUBn channel dead time output enable register	TAUBnTDE	<TAUBn_base0> + 250 _H
TAUBn channel dead time output level register	TAUBnTDL	<TAUBn_base1> + 54 _H
TAUBn simultaneous rewrite registers		
TAUBn channel reload data enable register	TAUBnRDE	<TAUBn_base0> + 260 _H
TAUBn channel reload data mode register	TAUBnRDM	<TAUBn_base0> + 264 _H
TAUBn channel reload data control channel select register	TAUBnRDS	<TAUBn_base0> + 268 _H
TAUBn channel reload data control register	TAUBnRDC	<TAUBn_base0> + 26C _H
TAUBn channel reload data trigger register	TAUBnRDT	<TAUBn_base1> + 44 _H
TAUBn channel reload status register	TAUBnRSF	<TAUBn_base1> + 48 _H

Note The <TAUBn_base> addresses of the registers are defined in the beginning of this section under the keyword “Register addresses”.

13.21.2 Details of TAUBn Prescaler Registers

(1) TAUBnTPS - TAUBn prescaler clock select register

This register specifies clocks CK0, CK1, CK2, and CK3 for all channels of the PCLK prescaler.

Access Readable/writable in 16-bit units.

Address <TAUBn_base0> + 240_H

Initial value FFFF_H

This register is initialized by any reset source.

15	14	13	12	11	10	9	8	7	6	5	4	3	2	1	0
TAUBnPRS3[3:0]				TAUBnPRS2[3:0]				TAUBnPRS1[3:0]				TAUBnPRS0[3:0]			
R/W	R/W	R/W	R/W	R/W	R/W	R/W	R/W	R/W	R/W	R/W	R/W	R/W	R/W	R/W	R/W

Table 13-122 Description of TAUBnTPS Register (1/4)

Bit Position	Bit Name	Function																																		
15 to 12	TAUBnPRS3 [3:0]	Specifies CK3 clock.																																		
		<table border="1"> <thead> <tr> <th>TAUBnPRS3[3:0]</th> <th>CK3 Clock</th> </tr> </thead> <tbody> <tr><td>0000_B</td><td>PCLK/2⁰</td></tr> <tr><td>0001_B</td><td>PCLK/2¹</td></tr> <tr><td>0010_B</td><td>PCLK/2²</td></tr> <tr><td>0011_B</td><td>PCLK/2³</td></tr> <tr><td>0100_B</td><td>PCLK/2⁴</td></tr> <tr><td>0101_B</td><td>PCLK/2⁵</td></tr> <tr><td>0110_B</td><td>PCLK/2⁶</td></tr> <tr><td>0111_B</td><td>PCLK/2⁷</td></tr> <tr><td>1000_B</td><td>PCLK/2⁸</td></tr> <tr><td>1001_B</td><td>PCLK/2⁹</td></tr> <tr><td>1010_B</td><td>PCLK/2¹⁰</td></tr> <tr><td>1011_B</td><td>PCLK/2¹¹</td></tr> <tr><td>1100_B</td><td>PCLK/2¹²</td></tr> <tr><td>1101_B</td><td>PCLK/2¹³</td></tr> <tr><td>1110_B</td><td>PCLK/2¹⁴</td></tr> <tr><td>1111_B</td><td>PCLK/2¹⁵</td></tr> </tbody> </table>	TAUBnPRS3[3:0]	CK3 Clock	0000 _B	PCLK/2 ⁰	0001 _B	PCLK/2 ¹	0010 _B	PCLK/2 ²	0011 _B	PCLK/2 ³	0100 _B	PCLK/2 ⁴	0101 _B	PCLK/2 ⁵	0110 _B	PCLK/2 ⁶	0111 _B	PCLK/2 ⁷	1000 _B	PCLK/2 ⁸	1001 _B	PCLK/2 ⁹	1010 _B	PCLK/2 ¹⁰	1011 _B	PCLK/2 ¹¹	1100 _B	PCLK/2 ¹²	1101 _B	PCLK/2 ¹³	1110 _B	PCLK/2 ¹⁴	1111 _B	PCLK/2 ¹⁵
TAUBnPRS3[3:0]	CK3 Clock																																			
0000 _B	PCLK/2 ⁰																																			
0001 _B	PCLK/2 ¹																																			
0010 _B	PCLK/2 ²																																			
0011 _B	PCLK/2 ³																																			
0100 _B	PCLK/2 ⁴																																			
0101 _B	PCLK/2 ⁵																																			
0110 _B	PCLK/2 ⁶																																			
0111 _B	PCLK/2 ⁷																																			
1000 _B	PCLK/2 ⁸																																			
1001 _B	PCLK/2 ⁹																																			
1010 _B	PCLK/2 ¹⁰																																			
1011 _B	PCLK/2 ¹¹																																			
1100 _B	PCLK/2 ¹²																																			
1101 _B	PCLK/2 ¹³																																			
1110 _B	PCLK/2 ¹⁴																																			
1111 _B	PCLK/2 ¹⁵																																			
		The above bits are rewritable only when all the counters using CK3 are stopped (TAUBnTE.TAUBnTEm = 0).																																		

Table 13-122 Description of TAUBnTPS Register (2/4)

Bit Position	Bit Name	Function																																		
11 to 8	TAUBnPRS2 [3:0]	Specifies prescaler output CK2 clock. <table border="1" data-bbox="571 338 1385 1061"> <thead> <tr> <th>TAUBnPRS2[3:0]</th> <th>Prescaler Output CK2 Clock</th> </tr> </thead> <tbody> <tr><td>0000_B</td><td>PCLK/2⁰</td></tr> <tr><td>0001_B</td><td>PCLK/2¹</td></tr> <tr><td>0010_B</td><td>PCLK/2²</td></tr> <tr><td>0011_B</td><td>PCLK/2³</td></tr> <tr><td>0100_B</td><td>PCLK/2⁴</td></tr> <tr><td>0101_B</td><td>PCLK/2⁵</td></tr> <tr><td>0110_B</td><td>PCLK/2⁶</td></tr> <tr><td>0111_B</td><td>PCLK/2⁷</td></tr> <tr><td>1000_B</td><td>PCLK/2⁸</td></tr> <tr><td>1001_B</td><td>PCLK/2⁹</td></tr> <tr><td>1010_B</td><td>PCLK/2¹⁰</td></tr> <tr><td>1011_B</td><td>PCLK/2¹¹</td></tr> <tr><td>1100_B</td><td>PCLK/2¹²</td></tr> <tr><td>1101_B</td><td>PCLK/2¹³</td></tr> <tr><td>1110_B</td><td>PCLK/2¹⁴</td></tr> <tr><td>1111_B</td><td>PCLK/2¹⁵</td></tr> </tbody> </table> <p>The above bits are rewritable only when all the counters using CK2 are stopped (TAUBnTE.TAUBnTEm = 0).</p>	TAUBnPRS2[3:0]	Prescaler Output CK2 Clock	0000 _B	PCLK/2 ⁰	0001 _B	PCLK/2 ¹	0010 _B	PCLK/2 ²	0011 _B	PCLK/2 ³	0100 _B	PCLK/2 ⁴	0101 _B	PCLK/2 ⁵	0110 _B	PCLK/2 ⁶	0111 _B	PCLK/2 ⁷	1000 _B	PCLK/2 ⁸	1001 _B	PCLK/2 ⁹	1010 _B	PCLK/2 ¹⁰	1011 _B	PCLK/2 ¹¹	1100 _B	PCLK/2 ¹²	1101 _B	PCLK/2 ¹³	1110 _B	PCLK/2 ¹⁴	1111 _B	PCLK/2 ¹⁵
TAUBnPRS2[3:0]	Prescaler Output CK2 Clock																																			
0000 _B	PCLK/2 ⁰																																			
0001 _B	PCLK/2 ¹																																			
0010 _B	PCLK/2 ²																																			
0011 _B	PCLK/2 ³																																			
0100 _B	PCLK/2 ⁴																																			
0101 _B	PCLK/2 ⁵																																			
0110 _B	PCLK/2 ⁶																																			
0111 _B	PCLK/2 ⁷																																			
1000 _B	PCLK/2 ⁸																																			
1001 _B	PCLK/2 ⁹																																			
1010 _B	PCLK/2 ¹⁰																																			
1011 _B	PCLK/2 ¹¹																																			
1100 _B	PCLK/2 ¹²																																			
1101 _B	PCLK/2 ¹³																																			
1110 _B	PCLK/2 ¹⁴																																			
1111 _B	PCLK/2 ¹⁵																																			

Table 13-122 Description of TAUBnTPS Register (3/4)

Bit Position	Bit Name	Function																																		
7 to 4	TAUBnPRS1 [3:0]	Specifies prescaler output CK1 clock. <table border="1" data-bbox="571 338 1385 1061"> <thead> <tr> <th>TAUBnPRS1[3:0]</th> <th>Prescaler Output CK1 Clock</th> </tr> </thead> <tbody> <tr><td>0000_B</td><td>PCLK/2⁰</td></tr> <tr><td>0001_B</td><td>PCLK/2¹</td></tr> <tr><td>0010_B</td><td>PCLK/2²</td></tr> <tr><td>0011_B</td><td>PCLK/2³</td></tr> <tr><td>0100_B</td><td>PCLK/2⁴</td></tr> <tr><td>0101_B</td><td>PCLK/2⁵</td></tr> <tr><td>0110_B</td><td>PCLK/2⁶</td></tr> <tr><td>0111_B</td><td>PCLK/2⁷</td></tr> <tr><td>1000_B</td><td>PCLK/2⁸</td></tr> <tr><td>1001_B</td><td>PCLK/2⁹</td></tr> <tr><td>1010_B</td><td>PCLK/2¹⁰</td></tr> <tr><td>1011_B</td><td>PCLK/2¹¹</td></tr> <tr><td>1100_B</td><td>PCLK/2¹²</td></tr> <tr><td>1101_B</td><td>PCLK/2¹³</td></tr> <tr><td>1110_B</td><td>PCLK/2¹⁴</td></tr> <tr><td>1111_B</td><td>PCLK/2¹⁵</td></tr> </tbody> </table> <p>The above bits are rewritable only when all the counters using CK1 are stopped (TAUBnTE.TAUBnTEm = 0).</p>	TAUBnPRS1[3:0]	Prescaler Output CK1 Clock	0000 _B	PCLK/2 ⁰	0001 _B	PCLK/2 ¹	0010 _B	PCLK/2 ²	0011 _B	PCLK/2 ³	0100 _B	PCLK/2 ⁴	0101 _B	PCLK/2 ⁵	0110 _B	PCLK/2 ⁶	0111 _B	PCLK/2 ⁷	1000 _B	PCLK/2 ⁸	1001 _B	PCLK/2 ⁹	1010 _B	PCLK/2 ¹⁰	1011 _B	PCLK/2 ¹¹	1100 _B	PCLK/2 ¹²	1101 _B	PCLK/2 ¹³	1110 _B	PCLK/2 ¹⁴	1111 _B	PCLK/2 ¹⁵
TAUBnPRS1[3:0]	Prescaler Output CK1 Clock																																			
0000 _B	PCLK/2 ⁰																																			
0001 _B	PCLK/2 ¹																																			
0010 _B	PCLK/2 ²																																			
0011 _B	PCLK/2 ³																																			
0100 _B	PCLK/2 ⁴																																			
0101 _B	PCLK/2 ⁵																																			
0110 _B	PCLK/2 ⁶																																			
0111 _B	PCLK/2 ⁷																																			
1000 _B	PCLK/2 ⁸																																			
1001 _B	PCLK/2 ⁹																																			
1010 _B	PCLK/2 ¹⁰																																			
1011 _B	PCLK/2 ¹¹																																			
1100 _B	PCLK/2 ¹²																																			
1101 _B	PCLK/2 ¹³																																			
1110 _B	PCLK/2 ¹⁴																																			
1111 _B	PCLK/2 ¹⁵																																			

Table 13-122 Description of TAUBnTPS Register (4/4)

Bit Position	Bit Name	Function																																		
3 to 0	TAUBnPRS0 [3:0]	Specifies prescaler output CK0 clock. <table border="1" data-bbox="571 338 1385 1061"> <thead> <tr> <th>TAUBnPRS0[3:0]</th> <th>Prescaler Output CK0 Clock</th> </tr> </thead> <tbody> <tr><td>0000_B</td><td>PCLK/2⁰</td></tr> <tr><td>0001_B</td><td>PCLK/2¹</td></tr> <tr><td>0010_B</td><td>PCLK/2²</td></tr> <tr><td>0011_B</td><td>PCLK/2³</td></tr> <tr><td>0100_B</td><td>PCLK/2⁴</td></tr> <tr><td>0101_B</td><td>PCLK/2⁵</td></tr> <tr><td>0110_B</td><td>PCLK/2⁶</td></tr> <tr><td>0111_B</td><td>PCLK/2⁷</td></tr> <tr><td>1000_B</td><td>PCLK/2⁸</td></tr> <tr><td>1001_B</td><td>PCLK/2⁹</td></tr> <tr><td>1010_B</td><td>PCLK/2¹⁰</td></tr> <tr><td>1011_B</td><td>PCLK/2¹¹</td></tr> <tr><td>1100_B</td><td>PCLK/2¹²</td></tr> <tr><td>1101_B</td><td>PCLK/2¹³</td></tr> <tr><td>1110_B</td><td>PCLK/2¹⁴</td></tr> <tr><td>1111_B</td><td>PCLK/2¹⁵</td></tr> </tbody> </table> <p>The above bits are rewritable only when all the counters using CK0 are stopped (TAUBnTE.TAUBnTEm = 0).</p>	TAUBnPRS0[3:0]	Prescaler Output CK0 Clock	0000 _B	PCLK/2 ⁰	0001 _B	PCLK/2 ¹	0010 _B	PCLK/2 ²	0011 _B	PCLK/2 ³	0100 _B	PCLK/2 ⁴	0101 _B	PCLK/2 ⁵	0110 _B	PCLK/2 ⁶	0111 _B	PCLK/2 ⁷	1000 _B	PCLK/2 ⁸	1001 _B	PCLK/2 ⁹	1010 _B	PCLK/2 ¹⁰	1011 _B	PCLK/2 ¹¹	1100 _B	PCLK/2 ¹²	1101 _B	PCLK/2 ¹³	1110 _B	PCLK/2 ¹⁴	1111 _B	PCLK/2 ¹⁵
TAUBnPRS0[3:0]	Prescaler Output CK0 Clock																																			
0000 _B	PCLK/2 ⁰																																			
0001 _B	PCLK/2 ¹																																			
0010 _B	PCLK/2 ²																																			
0011 _B	PCLK/2 ³																																			
0100 _B	PCLK/2 ⁴																																			
0101 _B	PCLK/2 ⁵																																			
0110 _B	PCLK/2 ⁶																																			
0111 _B	PCLK/2 ⁷																																			
1000 _B	PCLK/2 ⁸																																			
1001 _B	PCLK/2 ⁹																																			
1010 _B	PCLK/2 ¹⁰																																			
1011 _B	PCLK/2 ¹¹																																			
1100 _B	PCLK/2 ¹²																																			
1101 _B	PCLK/2 ¹³																																			
1110 _B	PCLK/2 ¹⁴																																			
1111 _B	PCLK/2 ¹⁵																																			

Note The TAUBn clock input PCLK is specified at the beginning of this section under the keyword "Clock supply".

13.21.3 Details of TAUBn Control Registers

(1) TAUBnCDRm - TAUBn channel data register m

This register functions either as a compare register or as a capture register, depending on the operating mode specified in TAUBnCMORm.TAUBnMD[4:1].

Access Readable/writable in 16-bit units.

- Readable in capture mode. Any write operation is ignored.
- Readable/writable in compare mode.

Address <TAUBn_base1> + 0_H + m × 4_H

Initial value 0000_H

This register is initialized by any reset source.

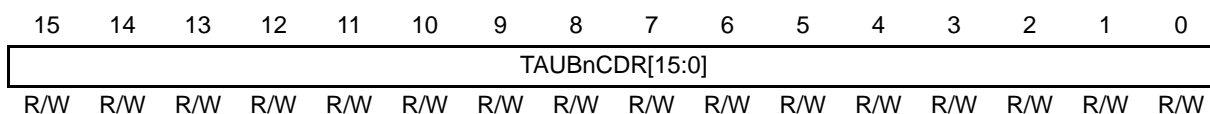

Table 13-123 Description of TAUBnCDRm Register

Bit Position	Bit Name	Function
15 to 0	TAUBnCDR [15:0]	Data register for capture/compare values

(2) TAUBnCNTm - TAUBn channel counter register m

This is a channel m counter register.

Access Readable in 16-bit units.

Address <TAUBn_base1> + 80_H + m × 4_H

Initial value 0000_H or FFFF_H

An initial value depends on an operating mode. See Table 13-125, TAUBnCNTm Read Values after Re-Enabling Counter. This register is initialized by any reset source.

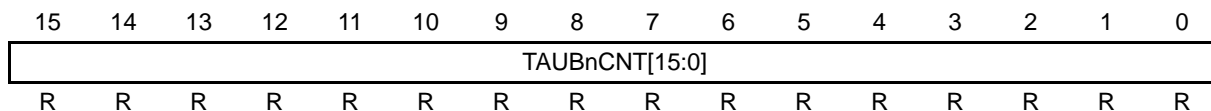

Table 13-124 Description of TAUBnCNTm Register

Bit Position	Bit Name	Function
15 to 0	TAUBnCNT [15:0]	16-bit counter value

A read value depends on a counter value, a changed operating mode, TAUBnTS.TAUBnTSm or TAUBnTT.TAUBnTTm bit value.

The initial read value of the counter depends on an operating mode and how the counter is stopped.

- Stop by a reset
- Stop by a counter stop trigger (TAUBnTT.TAUBnTTm = 1)

The following table lists the initial counter read values after the counter is stopped (TAUBnTE.TAUBnTEm = 0) and re-enabled (TAUBnTS.TAUBnTSm = 1).

The table also contains the counter read value one count after the counter is enabled (TAUBnTS.TAUBnTSm = 1) with the counter waiting for a start trigger.

Table 13-125 TAUBnCNTm Read Values after Re-Enabling Counter

Mode Name	Count Method (Up/Down)	TAUBnCNTm Value		
		After Reset	After Stop Trigger	After One Count
Interval timer mode	Count down	FFFF _H	Stop value	-
Judge mode	Count down	FFFF _H	Stop value	-
Capture mode	Count up	0000 _H	Stop value	-
Event count mode	Count dow	FFFF _H	Stop value	-
One-count mode	Count down	FFFF _H	Stop value	FFFF _H
Capture and one-count mode	Count up	0000 _H	Stop value	Capture value + 1 (TAUBnCDRm)
Judge and one-count mode	Count down	FFFF _H	Stop value	TAUBnCNTm value - 1
Up/down count mode	Count down/up	FFFF _H	Stop value	-
Pulse one count mode	Count down	FFFF _H	Stop value	0000 _H
Count capture mode	Count up	0000 _H	Stop value	-
Capture and gate count mode	Count up	0000 _H	Stop value	Stop value

Note If the operating mode is changed while the counter is stopped, the initial counter value after a counter restart becomes undefined. The operating mode is changed by the TAUBnCMORm.TAUBnMD[4:1] register.

(3) TAUBnCMORm - TAUBn channel mode OS register m

This register controls channel m operation.

Access Readable/writable in 16-bit units. Writable when the counter is stopped (TAUBnTE.TAUBnTEm = 0).

Address <TAUBn_base0> + 200_H + m × 4_H

Initial value 0000_H

This register is initialized by any reset source.

15	14	13	12	11	10	9	8	7	6	5	4	3	2	1	0
TAUBnCKS [1:0]	TAUBnCCS [1:0]	TAUBnMAS	TAUBnSTS[2:0]		TAUBnCOS [1:0]	-		TAUBnMD[4:0]							
R/W	R/W	R/W	R/W	R/W	R/W	R/W	R/W	R/W	R/W	R	R/W	R/W	R/W	R/W	R/W

Table 13-126 Description of TAUBnCMORm Register (1/4)

Bit Position	Bit Name	Function															
15, 14	TAUBnCKS [1:0]	Selects a sampling clock. An operation clock is used for the TAUBnTTINm input edge detection circuit. TAUBnCMORm.TAUBnCCS[1:0] bit setting enables use as a counter clock. <table border="1" style="margin-left: 20px;"> <thead> <tr> <th>TAUBnCKS1</th> <th>TAUBnCKS0</th> <th>Selection of Operation Clock</th> </tr> </thead> <tbody> <tr> <td>0</td> <td>0</td> <td>Prescaler output CK0</td> </tr> <tr> <td>0</td> <td>1</td> <td>Prescaler output CK1</td> </tr> <tr> <td>1</td> <td>0</td> <td>Prescaler output CK2</td> </tr> <tr> <td>1</td> <td>1</td> <td>Prescaler output CK3</td> </tr> </tbody> </table>	TAUBnCKS1	TAUBnCKS0	Selection of Operation Clock	0	0	Prescaler output CK0	0	1	Prescaler output CK1	1	0	Prescaler output CK2	1	1	Prescaler output CK3
TAUBnCKS1	TAUBnCKS0	Selection of Operation Clock															
0	0	Prescaler output CK0															
0	1	Prescaler output CK1															
1	0	Prescaler output CK2															
1	1	Prescaler output CK3															
12	TAUBnCCS0	Selects a count clock for TAUBnCNTm counter. <table border="1" style="margin-left: 20px;"> <thead> <tr> <th>TAUBnCCS0</th> <th>Selection of Count Clock</th> </tr> </thead> <tbody> <tr> <td>0</td> <td>Operation clock specified by TAUBnCMORm.TAUBnCKS[1:0]</td> </tr> <tr> <td>1</td> <td>Valid edge of TAUBnTTINm input signal</td> </tr> </tbody> </table>	TAUBnCCS0	Selection of Count Clock	0	Operation clock specified by TAUBnCMORm.TAUBnCKS[1:0]	1	Valid edge of TAUBnTTINm input signal									
TAUBnCCS0	Selection of Count Clock																
0	Operation clock specified by TAUBnCMORm.TAUBnCKS[1:0]																
1	Valid edge of TAUBnTTINm input signal																
11	TAUBnMAS	Specifies whether the channel is a master channel or slave channel during synchronous channel operation. 0: Slave 1: Master This bit setting is valid only for even channels (CHm_even). Odd channels (CHm_odd) are fixed to 0.															

Table 13-126 Description of TAUBnCMORm Register (2/4)

Bit Position	Bit Name	Function																																				
10 to 8	TAUBnSTS [2:0]	<p>Selects an external start trigger.</p> <table border="1"> <thead> <tr> <th>TAUBnSTS2</th> <th>TAUBnSTS1</th> <th>TAUBnSTS0</th> <th>Functional Description</th> </tr> </thead> <tbody> <tr> <td>0</td> <td>0</td> <td>0</td> <td>Software trigger</td> </tr> <tr> <td>0</td> <td>0</td> <td>1</td> <td>Valid edge of TAUBnTTINm input signal, which is specified by TAUBnCMURm.TAUBnTIS[1:0].</td> </tr> <tr> <td>0</td> <td>1</td> <td>0</td> <td>Valid edge of TAUBnTTINm input signal is used as a start trigger and the opposite edge as a stop trigger.</td> </tr> <tr> <td>0</td> <td>1</td> <td>1</td> <td>Simultaneous rewrite trigger</td> </tr> <tr> <td>1</td> <td>0</td> <td>0</td> <td>INT of master channel</td> </tr> <tr> <td>1</td> <td>0</td> <td>1</td> <td>INT of upper channel (m - 1) regardless of master setting</td> </tr> <tr> <td>1</td> <td>1</td> <td>0</td> <td>Dead time output signal of TAUBnTTOUTm generating unit</td> </tr> <tr> <td>1</td> <td>1</td> <td>1</td> <td>Up/down output trigger signal of master channel</td> </tr> </tbody> </table>	TAUBnSTS2	TAUBnSTS1	TAUBnSTS0	Functional Description	0	0	0	Software trigger	0	0	1	Valid edge of TAUBnTTINm input signal, which is specified by TAUBnCMURm.TAUBnTIS[1:0].	0	1	0	Valid edge of TAUBnTTINm input signal is used as a start trigger and the opposite edge as a stop trigger.	0	1	1	Simultaneous rewrite trigger	1	0	0	INT of master channel	1	0	1	INT of upper channel (m - 1) regardless of master setting	1	1	0	Dead time output signal of TAUBnTTOUTm generating unit	1	1	1	Up/down output trigger signal of master channel
TAUBnSTS2	TAUBnSTS1	TAUBnSTS0	Functional Description																																			
0	0	0	Software trigger																																			
0	0	1	Valid edge of TAUBnTTINm input signal, which is specified by TAUBnCMURm.TAUBnTIS[1:0].																																			
0	1	0	Valid edge of TAUBnTTINm input signal is used as a start trigger and the opposite edge as a stop trigger.																																			
0	1	1	Simultaneous rewrite trigger																																			
1	0	0	INT of master channel																																			
1	0	1	INT of upper channel (m - 1) regardless of master setting																																			
1	1	0	Dead time output signal of TAUBnTTOUTm generating unit																																			
1	1	1	Up/down output trigger signal of master channel																																			

Table 13-126 Description of TAUBnCMORm Register (3/4)

Bit Position	Bit Name	Function																				
7, 6	TAUBnCOS [1:0]	<p>Specifies the timing for updating capture register TAUBnCDRm and overflow flag TAUBnCSRm.TAUBnOVF of channel m. These bits are valid only when channel m is in capture mode.</p> <table border="1"> <thead> <tr> <th>TAUBn COS1</th> <th>TAUBn COS0</th> <th>TAUBnCDRm</th> <th>TAUBnCSRm.TAUBnOVF</th> </tr> </thead> <tbody> <tr> <td>0</td> <td>0</td> <td>Updated upon detection of valid edge of TAUBnTTINm input.</td> <td> Updated (cleared or set) by detecting valid edge of TAUBnTTINm input: <ul style="list-style-type: none"> If a counter overflow has occurred since the last detection of valid edge, set TAUBnCSRm.TAUBnOVF. If no counter overflow has occurred since the last detection of valid edge, clear TAUBnCSRm.TAUBnOVF. </td> </tr> <tr> <td>0</td> <td>1</td> <td></td> <td>Set when a counter overflow occurs, and cleared when TAUBnCSCm.TAUBnCLOV is set to 1.</td> </tr> <tr> <td>1</td> <td>0</td> <td>Updated upon detection of valid edge of TAUBnTTINm input</td> <td>Not set</td> </tr> <tr> <td>1</td> <td>1</td> <td> Updated upon detection of valid edge of TAUBnTTINm input and at the occurrence of counter overflow: <ul style="list-style-type: none"> Detection of valid edge of TAUBnTTINm input: Counter value is written into TAUBnCDRm. Occurrence of overflow: FFFF_H is loaded into TAUBnCDRm. The next detection of valid of TAUBnTTINm input is ignored. </td> <td>Set when a counter overflow occurs, and cleared when TAUBnCSCm.TAUBnCLOV is set to 1.</td> </tr> </tbody> </table>	TAUBn COS1	TAUBn COS0	TAUBnCDRm	TAUBnCSRm.TAUBnOVF	0	0	Updated upon detection of valid edge of TAUBnTTINm input.	Updated (cleared or set) by detecting valid edge of TAUBnTTINm input: <ul style="list-style-type: none"> If a counter overflow has occurred since the last detection of valid edge, set TAUBnCSRm.TAUBnOVF. If no counter overflow has occurred since the last detection of valid edge, clear TAUBnCSRm.TAUBnOVF. 	0	1		Set when a counter overflow occurs, and cleared when TAUBnCSCm.TAUBnCLOV is set to 1.	1	0	Updated upon detection of valid edge of TAUBnTTINm input	Not set	1	1	Updated upon detection of valid edge of TAUBnTTINm input and at the occurrence of counter overflow: <ul style="list-style-type: none"> Detection of valid edge of TAUBnTTINm input: Counter value is written into TAUBnCDRm. Occurrence of overflow: FFFF_H is loaded into TAUBnCDRm. The next detection of valid of TAUBnTTINm input is ignored. 	Set when a counter overflow occurs, and cleared when TAUBnCSCm.TAUBnCLOV is set to 1.
TAUBn COS1	TAUBn COS0	TAUBnCDRm	TAUBnCSRm.TAUBnOVF																			
0	0	Updated upon detection of valid edge of TAUBnTTINm input.	Updated (cleared or set) by detecting valid edge of TAUBnTTINm input: <ul style="list-style-type: none"> If a counter overflow has occurred since the last detection of valid edge, set TAUBnCSRm.TAUBnOVF. If no counter overflow has occurred since the last detection of valid edge, clear TAUBnCSRm.TAUBnOVF. 																			
0	1		Set when a counter overflow occurs, and cleared when TAUBnCSCm.TAUBnCLOV is set to 1.																			
1	0	Updated upon detection of valid edge of TAUBnTTINm input	Not set																			
1	1	Updated upon detection of valid edge of TAUBnTTINm input and at the occurrence of counter overflow: <ul style="list-style-type: none"> Detection of valid edge of TAUBnTTINm input: Counter value is written into TAUBnCDRm. Occurrence of overflow: FFFF_H is loaded into TAUBnCDRm. The next detection of valid of TAUBnTTINm input is ignored. 	Set when a counter overflow occurs, and cleared when TAUBnCSCm.TAUBnCLOV is set to 1.																			

Table 13-126 Description of TAUBnCMORm Register (4/4)

Bit Position	Bit Name	Function																																																																																										
4 to 0	TAUBnMD [4:0]	Specifies an operating mode. <table border="1"> <thead> <tr> <th>TAUBn MD4</th> <th>TAUBn MD3</th> <th>TAUBn MD2</th> <th>TAUBn MD1</th> <th>TAUBn MD0</th> <th>Functional Description</th> </tr> </thead> <tbody> <tr> <td>0</td> <td>0</td> <td>0</td> <td>0</td> <td>1/0</td> <td>Interval timer mode</td> </tr> <tr> <td>0</td> <td>0</td> <td>0</td> <td>1</td> <td>1/0</td> <td>Judge mode</td> </tr> <tr> <td>0</td> <td>0</td> <td>1</td> <td>0</td> <td>1/0</td> <td>Capture mode</td> </tr> <tr> <td>0</td> <td>0</td> <td>1</td> <td>1</td> <td>0</td> <td>Event count mode</td> </tr> <tr> <td>0</td> <td>1</td> <td>0</td> <td>0</td> <td>1/0</td> <td>One-count mode</td> </tr> <tr> <td>0</td> <td>1</td> <td>0</td> <td>1</td> <td>1/0</td> <td>Setting prohibited</td> </tr> <tr> <td>0</td> <td>1</td> <td>1</td> <td>0</td> <td>0</td> <td>Capture and one-count mode</td> </tr> <tr> <td>0</td> <td>1</td> <td>1</td> <td>1</td> <td>1/0</td> <td>Judge and one-count mode</td> </tr> <tr> <td>1</td> <td>0</td> <td>0</td> <td>0</td> <td>0</td> <td>Setting prohibited</td> </tr> <tr> <td>1</td> <td>0</td> <td>0</td> <td>1</td> <td>0</td> <td>Up/down count mode</td> </tr> <tr> <td>1</td> <td>0</td> <td>1</td> <td>0</td> <td>1/0</td> <td>Pulse one-count mode</td> </tr> <tr> <td>1</td> <td>0</td> <td>1</td> <td>1</td> <td>1/0</td> <td>Count capture mode</td> </tr> <tr> <td>1</td> <td>1</td> <td>0</td> <td>0</td> <td>1/0</td> <td>Setting prohibited</td> </tr> <tr> <td>1</td> <td>1</td> <td>0</td> <td>1</td> <td>0</td> <td>Capture and gate count mode</td> </tr> </tbody> </table>	TAUBn MD4	TAUBn MD3	TAUBn MD2	TAUBn MD1	TAUBn MD0	Functional Description	0	0	0	0	1/0	Interval timer mode	0	0	0	1	1/0	Judge mode	0	0	1	0	1/0	Capture mode	0	0	1	1	0	Event count mode	0	1	0	0	1/0	One-count mode	0	1	0	1	1/0	Setting prohibited	0	1	1	0	0	Capture and one-count mode	0	1	1	1	1/0	Judge and one-count mode	1	0	0	0	0	Setting prohibited	1	0	0	1	0	Up/down count mode	1	0	1	0	1/0	Pulse one-count mode	1	0	1	1	1/0	Count capture mode	1	1	0	0	1/0	Setting prohibited	1	1	0	1	0	Capture and gate count mode
TAUBn MD4	TAUBn MD3	TAUBn MD2	TAUBn MD1	TAUBn MD0	Functional Description																																																																																							
0	0	0	0	1/0	Interval timer mode																																																																																							
0	0	0	1	1/0	Judge mode																																																																																							
0	0	1	0	1/0	Capture mode																																																																																							
0	0	1	1	0	Event count mode																																																																																							
0	1	0	0	1/0	One-count mode																																																																																							
0	1	0	1	1/0	Setting prohibited																																																																																							
0	1	1	0	0	Capture and one-count mode																																																																																							
0	1	1	1	1/0	Judge and one-count mode																																																																																							
1	0	0	0	0	Setting prohibited																																																																																							
1	0	0	1	0	Up/down count mode																																																																																							
1	0	1	0	1/0	Pulse one-count mode																																																																																							
1	0	1	1	1/0	Count capture mode																																																																																							
1	1	0	0	1/0	Setting prohibited																																																																																							
1	1	0	1	0	Capture and gate count mode																																																																																							
Mode	Role of TAUBnMD0 Bit																																																																																											
Interval timer mode Capture mode Count capture mode	Specifies whether INTTAUBnIm is generated at the beginning of count operation (when a start trigger is entered) or not. 0: INTTAUBnIm is not generated. 1: INTTAUBnIm is generated.																																																																																											
Event count mode Up/down count mode	This bit should be set to 0.																																																																																											
One-count mode Pulse one-count mode	Enables/disables start trigger detection during counting. 0: Disables detection. 1: Enables detection.																																																																																											
Capture and one-count mode Capture and gate count mode	This bit should be set to 0.																																																																																											
Judge mode Judge and one-count mode	Specifies INTTAUBnIm output timing. 0: When TAUBnCNTm ≤ TAUBnCDRm 1: When TAUBnCNTm > TAUBnCDRm																																																																																											

(4) TAUBnCMURm - TAUBn channel mode user register m

This register specifies a type of valid edge detection used for TAUBnTTINm input.

Access Readable/writable in 8-bit units.

Address <TAUBn_base1> + C0_H + m × 4_H

Initial value 00_H

This register is initialized by any reset source.

7	6	5	4	3	2	1	0
-	-	-	-	-	-	TAUBnTIS[1:0]	
R	R	R	R	R	R	R/W	R/W

Table 13-127 Description of TAUBnCMURm Register

Bit Position	Bit Name	Function															
1, 0	TAUBnTIS [1:0]	<p>Specifies a valid edge of TAUBnTTINm input signal.</p> <table border="1"> <thead> <tr> <th>TAUBnTIS1</th> <th>TAUBnTIS0</th> <th>Functional Description</th> </tr> </thead> <tbody> <tr> <td>0</td> <td>0</td> <td>Falling edge</td> </tr> <tr> <td>0</td> <td>1</td> <td>Rising edge</td> </tr> <tr> <td>1</td> <td>0</td> <td>Detects both of falling and rising edges (Selects low width measurement) Start trigger: Falling edge Stop trigger (capture): Rising edge</td> </tr> <tr> <td>1</td> <td>1</td> <td>Detects both of falling and rising edges (Selects high width measurement) Start trigger: Rising edge Stop trigger (capture): Falling edge</td> </tr> </tbody> </table> <ul style="list-style-type: none"> Edge detection of TAUBnTTINm input signal is based on the operation clock selected by TAUBnCMORm.TAUBnCKS[1:0]. 	TAUBnTIS1	TAUBnTIS0	Functional Description	0	0	Falling edge	0	1	Rising edge	1	0	Detects both of falling and rising edges (Selects low width measurement) Start trigger: Falling edge Stop trigger (capture): Rising edge	1	1	Detects both of falling and rising edges (Selects high width measurement) Start trigger: Rising edge Stop trigger (capture): Falling edge
TAUBnTIS1	TAUBnTIS0	Functional Description															
0	0	Falling edge															
0	1	Rising edge															
1	0	Detects both of falling and rising edges (Selects low width measurement) Start trigger: Falling edge Stop trigger (capture): Rising edge															
1	1	Detects both of falling and rising edges (Selects high width measurement) Start trigger: Rising edge Stop trigger (capture): Falling edge															

(5) TAUBnCSRm - TAUBn channel status register m

This register indicates the count direction and overflow status of channel m counter.

Access Readable in 8-bit units.

Address <TAUBn_base1> + 140_H + m × 4_H

Initial value 00_H

This register is initialized by any reset source.

7	6	5	4	3	2	1	0
-	-	-	-	-	-	TAUBnCSF	TAUBnOVF
R	R	R	R	R	R	R	R

Table 13-128 Description of TAUBnCSRm Register

Bit Position	Bit Name	Function
1	TAUBnCSF	Indicates a count direction. 0: Count-up 1: Count-down The read value of this bit is valid only in the following mode: <ul style="list-style-type: none"> Up/down count
0	TAUBnOVF	Indicates counter overflow status. 0: No overflow occurs. 1: Overflow occurs. This bit is used only in the following modes: <ul style="list-style-type: none"> Capture mode Capture and one-count mode <p>The function of this bit depends on the setting of control bit TAUBnCMORm.TAUBnCOS[1:0].</p>

(6) TAUBnCSCm - TAUBn channel status clear trigger register m

This is a trigger register for clearing the overflow flag TAUBnCSRm.TAUBnOVF of channel m.

Access Writable in 8-bit units. This value is always read as 00_H.

Address <TAUBn_base1> + 180_H + m × 4_H

Initial value 00_H

This register is initialized by any reset source.

7	6	5	4	3	2	1	0
-	-	-	-	-	-	0	TAUBnCLOV
R	R	R	R	R	R	R	W

Table 13-129 Description of TAUBnCSCm Register

Bit Position	Bit Name	Function
0	TAUBnCLOV	0: Invalid (Setting 0 does not affect the overflow flag TAUBnCSRm.TAUBnOVF) 1: Clears overflow flag TAUBnCSRm.TAUBnOVF.

(7) TAUBnTS - TAUBn channel start trigger register

This register enables the counter operation of each channel.

Access Writable in 16-bit units. This value is always read as 0000_H.

Address <TAUBn_base1> + 1C4_H

Initial value 0000_H

This register is initialized by any reset source.

15	14	13	12	11	10	9	8	7	6	5	4	3	2	1	0
TAUBnTS15	TAUBnTS14	TAUBnTS13	TAUBnTS12	TAUBnTS11	TAUBnTS10	TAUBnTS09	TAUBnTS08	TAUBnTS07	TAUBnTS06	TAUBnTS05	TAUBnTS04	TAUBnTS03	TAUBnTS02	TAUBnTS01	TAUBnTS00
W	W	W	W	W	W	W	W	W	W	W	W	W	W	W	W

Table 13-130 Description of TAUBnTS Register

Bit Position	Bit Name	Function
15 to 0	TAUBnTSM	Enables the counter operation of channel m. 0: Invalid (Setting 0 does not start counter operation of channel m) 1: Enables the counter operation and sets TAUBnTE.TAUBnTEm to 1. The counter operation is only enabled when TAUBnTE.TAUBnTEm is set to 1. Whether counting is started or not depends on a selected operating mode.

(8) TAUBnTE - TAUBn channel enable status register

This register enables/disables a counter operation.

Access Readable in 16-bit units.

Address <TAUBn_base1> + 1C0_H

Initial value 0000_H

This register is initialized by any reset source.

15	14	13	12	11	10	9	8	7	6	5	4	3	2	1	0
TAUBnTE	TAUBnTE	TAUBnTE	TAUBnTE	TAUBnTE	TAUBnTE	TAUBnTE	TAUBnTE	TAUBnTE	TAUBnTE	TAUBnTE	TAUBnTE	TAUBnTE	TAUBnTE	TAUBnTE	TAUBnTE
15	14	13	12	11	10	09	08	07	06	05	04	03	02	01	00
R	R	R	R	R	R	R	R	R	R	R	R	R	R	R	R

Table 13-131 Description of TAUBnTE Register

Bit Position	Bit Name	Function
15 to 0	TAUBnTE _m	Enables/disables the counter operation of channel m. 0: Disables counter operation. 1: Enables counter operation. This bit is set to 1 when trigger input of TAUBnTSST _m (synchronous channel start trigger signal) is detected or when TAUBnTS.TAUBnTS _m is set to 1. This bit is set to 0 when TAUBnTT.TAUBnTT _m is set to 1.

(9) TAUBnTT - TAUBn channel stop trigger register

This register stops the counter operation of each channel.

Access Writable in 16-bit units. This value is always read as 0000_H.

Address <TAUBn_base1> + 1C8_H

Initial value 0000_H

This register is initialized by any reset source.

15	14	13	12	11	10	9	8	7	6	5	4	3	2	1	0
TAUBnTT	TAUBnTT	TAUBnTT	TAUBnTT	TAUBnTT	TAUBnTT	TAUBnTT	TAUBnTT	TAUBnTT	TAUBnTT	TAUBnTT	TAUBnTT	TAUBnTT	TAUBnTT	TAUBnTT	TAUBnTT
15	14	13	12	11	10	09	08	07	06	05	04	03	02	01	00
W	W	W	W	W	W	W	W	W	W	W	W	W	W	W	W

Table 13-132 Description of TAUBnTT Register

Bit Position	Bit Name	Function
15 to 0	TAUBnTT _m	Stops the counter operation of channel m. 0: Invalid (Setting 0 does not start counter operation of channel m) 1: Stops the counter operation and resets TAUBnTE.TAUBnTE _m . TAUBnCNT _m , TAUBnTO.TAUBnTO _m , and TAUBnTTOUT _m retain the values provided before the counter is stopped.

13.21.4 Details of TAUBn Output Registers

(1) TAUBnTOE - TAUBn channel output enable register

This register enables/disables the independent channel output mode controlled by software.

Access Readable/writable in 16-bit units. Writable only while the counter is stopped (TAUBnTE.TAUBnTE_m = 0).

Address <TAUBn_base1> + 5C_H

Initial value 0000_H

This register is initialized by any reset source.

15	14	13	12	11	10	9	8	7	6	5	4	3	2	1	0
TAUB nTOE	TAUB nTOE	TAUB nTOE	TAUB nTOE	TAUB nTOE	TAUB nTOE	TAUB nTOE	TAUB nTOE	TAUB nTOE	TAUB nTOE	TAUB nTOE	TAUB nTOE	TAUB nTOE	TAUB nTOE	TAUB nTOE	TAUB nTOE
15	14	13	12	11	10	09	08	07	06	05	04	03	02	01	00
R/W	R/W	R/W	R/W	R/W	R/W	R/W	R/W	R/W	R/W	R/W	R/W	R/W	R/W	R/W	R/W

Table 13-133 Description of TAUBnTOE Register

Bit Position	Bit Name	Function
15 to 0	TAUBnTOEm	Enables/disables the independent timer output function. 0: Disables the independent timer output function (software control). 1: Enables the independent timer output function.

(2) TAUBnTOM - TAUBn channel output mode register

This register specifies the output mode of each channel.

Access Readable/writable in 16-bit units. Writable only while the counter is stopped (TAUBnTE.TAUBnTE_m = 0).

Address <TAUBn_base0> + 248_H

Initial value 0000_H

This register is initialized by any reset source.

15	14	13	12	11	10	9	8	7	6	5	4	3	2	1	0
TAUB nTOM	TAUB nTOM	TAUB nTOM	TAUB nTOM	TAUB nTOM	TAUB nTOM	TAUB nTOM	TAUB nTOM	TAUB nTOM	TAUB nTOM	TAUB nTOM	TAUB nTOM	TAUB nTOM	TAUB nTOM	TAUB nTOM	TAUB nTOM
15	14	13	12	11	10	09	08	07	06	05	04	03	02	01	00
R/W	R/W	R/W	R/W	R/W	R/W	R/W	R/W	R/W	R/W	R/W	R/W	R/W	R/W	R/W	R/W

Table 13-134 Description of TAUBnTOM Register

Bit Position	Bit Name	Function
15 to 0	TAUBnTOMm	Specifies an output mode. 0: Independent channel operation 1: Synchronous channel operation As described in Table 13-10, Channel Output Modes, the output mode depends on the setting of each channel output control bit.

(3) TAUBnTOC - TAUBn channel output configuration register

This register specifies the output mode of each channel in combination with TAUBnTOMm.

Access Readable/writable in 16-bit units. Writable only while the counter is stopped (TAUBnTE.TAUBnTEm = 0).

Address <TAUBn_base0> + 24C_H

Initial value 0000_H

This register is initialized by any reset source.

15	14	13	12	11	10	9	8	7	6	5	4	3	2	1	0
TAUBnTOC 15	TAUBnTOC 14	TAUBnTOC 13	TAUBnTOC 12	TAUBnTOC 11	TAUBnTOC 10	TAUBnTOC 09	TAUBnTOC 08	TAUBnTOC 07	TAUBnTOC 06	TAUBnTOC 05	TAUBnTOC 04	TAUBnTOC 03	TAUBnTOC 02	TAUBnTOC 01	TAUBnTOC 00
R/W	R/W	R/W	R/W	R/W	R/W	R/W	R/W	R/W	R/W	R/W	R/W	R/W	R/W	R/W	R/W

Table 13-135 Description of TAUBnTOC Register

Bit Position	Bit Name	Function													
15 to 0	TAUBnTOCm	Specifies an output mode. 0: Operating mode 1 1: Operating mode 2 As listed below, the output mode depends on the setting of TAUBnTOM.TAUBnTOMm.													
<table border="1"> <thead> <tr> <th>TOMm</th> <th>TOCm</th> <th>Functional Description</th> </tr> </thead> <tbody> <tr> <td rowspan="2">0</td> <td>0</td> <td>Toggle mode: Toggle operation is conducted when INTTAUBnIm occurs.</td> </tr> <tr> <td>1</td> <td>Set/reset mode: Set when INTTAUBnIm occurs at the beginning of count operation, and reset when INTTAUBnIm is caused by detection of a match between TAUBnCNTm and TAUBnCDRm.</td> </tr> <tr> <td rowspan="2">1</td> <td>0</td> <td>Synchronous channel operating mode 1: Set when INT occurs on master channels, and reset when INT occurs on slave channels.</td> </tr> <tr> <td>1</td> <td>Synchronous channel operating mode 2: Set when INTTAUBnIm occurs in count-down status, and reset when INTTAUBnIm occurs in count-up status.</td> </tr> </tbody> </table>			TOMm	TOCm	Functional Description	0	0	Toggle mode: Toggle operation is conducted when INTTAUBnIm occurs.	1	Set/reset mode: Set when INTTAUBnIm occurs at the beginning of count operation, and reset when INTTAUBnIm is caused by detection of a match between TAUBnCNTm and TAUBnCDRm.	1	0	Synchronous channel operating mode 1: Set when INT occurs on master channels, and reset when INT occurs on slave channels.	1	Synchronous channel operating mode 2: Set when INTTAUBnIm occurs in count-down status, and reset when INTTAUBnIm occurs in count-up status.
TOMm	TOCm	Functional Description													
0	0	Toggle mode: Toggle operation is conducted when INTTAUBnIm occurs.													
	1	Set/reset mode: Set when INTTAUBnIm occurs at the beginning of count operation, and reset when INTTAUBnIm is caused by detection of a match between TAUBnCNTm and TAUBnCDRm.													
1	0	Synchronous channel operating mode 1: Set when INT occurs on master channels, and reset when INT occurs on slave channels.													
	1	Synchronous channel operating mode 2: Set when INTTAUBnIm occurs in count-down status, and reset when INTTAUBnIm occurs in count-up status.													

(4) TAUBnTDE - TAUBn channel dead time output enable register

This register enables/disables the dead time operation of every channel.

Access Readable/writable in 16-bit units. Writable only while the counter is stopped (TAUBnTE.TAUBnTE_m bit = 0).

Address <TAUBn_base0> + 250_H

Initial value 0000_H

This register is initialized by any reset source.

15	14	13	12	11	10	9	8	7	6	5	4	3	2	1	0
TAUBnTDE 15	TAUBnTDE 14	TAUBnTDE 13	TAUBnTDE 12	TAUBnTDE 11	TAUBnTDE 10	TAUBnTDE 09	TAUBnTDE 08	TAUBnTDE 07	TAUBnTDE 06	TAUBnTDE 05	TAUBnTDE 04	TAUBnTDE 03	TAUBnTDE 02	TAUBnTDE 01	TAUBnTDE 00
R/W	R/W	R/W	R/W	R/W	R/W	R/W	R/W	R/W	R/W	R/W	R/W	R/W	R/W	R/W	R/W

Table 13-136 Description of TAUBnTDE Register

Bit Position	Bit Name	Function
15 to 0	TAUBnTDE _m	Enables/disables the dead time control operation of channel m. 0: Disables dead time operation. 1: Enables dead time operation. The same setting should be made for both even and odd slave channels in pairs. These bit settings are applied when: <ul style="list-style-type: none"> TAUBnTOE.TAUBnTOE_m, TAUBnTOM.TAUBnTOM_m, TAUBnTOC.TAUBnTOC_m = 1

(5) TAUBnTDL - TAUBn channel dead time output level register

This register selects a phase in which dead time is added.

Access Readable/writable in 16-bit units. Writable only while the counter is stopped (TAUBnTE.TAUBnTE_m bit = 0) Writable only while the counter is stopped (TAUBnTE.TAUBnTE_m = 0).

Address <TAUBn_base1> + 54_H

Initial value 0000_H

This register is initialized by any reset source.

15	14	13	12	11	10	9	8	7	6	5	4	3	2	1	0
TAUBnTDL 15	TAUBnTDL 14	TAUBnTDL 13	TAUBnTDL 12	TAUBnTDL 11	TAUBnTDL 10	TAUBnTDL 09	TAUBnTDL 08	TAUBnTDL 07	TAUBnTDL 06	TAUBnTDL 05	TAUBnTDL 04	TAUBnTDL 03	TAUBnTDL 02	TAUBnTDL 01	TAUBnTDL 00
R/W	R/W	R/W	R/W	R/W	R/W	R/W	R/W	R/W	R/W	R/W	R/W	R/W	R/W	R/W	R/W

Table 13-137 Description of TAUBnTDL Register

Bit Position	Bit Name	Function
15 to 0	TAUBnTDLm	Selects a phase in which dead time is added. 0: Positive phase 1: Negative phase These bit settings are applied when: <ul style="list-style-type: none"> TAUBnTOE.TAUBnTOEm, TAUBnTOM.TAUBnTOMm, TAUBnTOC.TAUBnTOCm, TAUBnTDE.TAUBnTDEm = 1

13.21.5 Details of TAUBn Channel Output Level Registers

(1) TAUBnTO - TAUBn channel output register

This register specifies and reads a TAUBnTTOUTm level.

Access Readable/writable in 16-bit units.

Address <TAUBn_base1> + 58_H

Initial value 0000_H

This register is initialized by any reset source.

15	14	13	12	11	10	9	8	7	6	5	4	3	2	1	0
TAUB nTO	TAUB nTO	TAUB nTO	TAUB nTO	TAUB nTO	TAUB nTO	TAUB nTO	TAUB nTO	TAUB nTO	TAUB nTO	TAUB nTO	TAUB nTO	TAUB nTO	TAUB nTO	TAUB nTO	TAUB nTO
15	14	13	12	11	10	09	08	07	06	05	04	03	02	01	00
R/W	R/W	R/W	R/W	R/W	R/W	R/W	R/W	R/W	R/W	R/W	R/W	R/W	R/W	R/W	R/W

Table 13-138 Description of TAUBnTO Register

Bit Position	Bit Name	Function
15 to 0	TAUBnTOm	Specifies/reads a TAUBnTTOUTm level. 0: Low level 1: High level TAUBnTOm bit is writable when independent channel output function is disabled (TAUBnTOE.TAUBnTOEm = 0).

(2) TAUBnTOL - TAUBn channel output active level register

This register specifies the output logic of channel output bit (TAUBnTO.TAUBnTOm).

Access Readable/writable in 16-bit units.

Address <TAUBn_base1> + 40_H

Initial value 0000_H

This register is initialized by any reset source.

15	14	13	12	11	10	9	8	7	6	5	4	3	2	1	0
TAUB nTOL	TAUB nTOL	TAUB nTOL	TAUB nTOL	TAUB nTOL	TAUB nTOL	TAUB nTOL	TAUB nTOL	TAUB nTOL	TAUB nTOL	TAUB nTOL	TAUB nTOL	TAUB nTOL	TAUB nTOL	TAUB nTOL	TAUB nTOL
15	14	13	12	1	10	09	08	07	06	05	04	03	02	01	00
R/W	R/W	R/W	R/W	R/W	R/W	R/W	R/W	R/W	R/W	R/W	R/W	R/W	R/W	R/W	R/W

Table 13-139 Description of TAUBnTOL Register

Bit Position	Bit Name	Function
15 to 0	TAUBnTOLm	Specifies the output logic of channel m output bit (TAUBnTO.TAUBnTOm). 0: Positive logic (active high) 1: Inverted logic (active low)

13.21.6 Details of TAUBn Simultaneous Rewrite Registers

(1) TAUBnRDE - TAUBn channel reload data enable register

This register enables/disables simultaneous rewrite of TAUBnCDRm/TAUBnTOLm data register.

Access Readable/writable in 16-bit units. Writable only while the counter is stopped (TAUBnTE.TAUBnTEm = 0).

Address <TAUBn_base0> + 260_H

Initial value 0000_H

This register is initialized by any reset source.

15	14	13	12	11	10	9	8	7	6	5	4	3	2	1	0
TAUBnRDE	TAUBnRDE	TAUBnRDE	TAUBnRDE	TAUBnRDE	TAUBnRDE	TAUBnRDE	TAUBnRDE	TAUBnRDE	TAUBnRDE	TAUBnRDE	TAUBnRDE	TAUBnRDE	TAUBnRDE	TAUBnRDE	TAUBnRDE
15	14	13	12	11	10	09	08	07	06	05	04	03	02	01	00
R/W	R/W	R/W	R/W	R/W	R/W	R/W	R/W	R/W	R/W	R/W	R/W	R/W	R/W	R/W	R/W

Table 13-140 Description of TAUBnRDE Register

Bit Position	Bit Name	Function
15 to 0	TAUBnRDEm	Enables/disables simultaneous rewrite of the data register of channel m. 0: Disables simultaneous rewrite. 1: Enables simultaneous rewrite.

(2) TAUBnRDS - TAUBn channel reload data control channel select register

This register selects a channel that controls simultaneous rewrite.

Access Readable/writable in 16-bit units. Writable only while the counter is stopped (TAUBnTE.TAUBnTEm = 0).

Address <TAUBn_base0> + 268_H

Initial value 0000_H

This register is initialized by any reset source.

15	14	13	12	11	10	9	8	7	6	5	4	3	2	1	0
TAUBnRDS	TAUBnRDS	TAUBnRDS	TAUBnRDS	TAUBnRDS	TAUBnRDS	TAUBnRDS	TAUBnRDS	TAUBnRDS	TAUBnRDS	TAUBnRDS	TAUBnRDS	TAUBnRDS	TAUBnRDS	TAUBnRDS	TAUBnRDS
15	14	13	12	11	10	09	08	07	06	05	04	03	02	01	00
R/W	R/W	R/W	R/W	R/W	R/W	R/W	R/W	R/W	R/W	R/W	R/W	R/W	R/W	R/W	R/W

Table 13-141 Description of TAUBnRDS Register

Bit Position	Bit Name	Function
15 to 0	TAUBnRDSm	Selects a channel that monitors a simultaneous rewrite trigger. 0: Master channel 1: Another upper channel

(3) TAUBnRDM - TAUBn channel reload data mode register

This register selects the timing for generating a simultaneous rewrite control signal.

Access Readable/writable in 16-bit units. Writable only while the counter is stopped (TAUBnTE.TAUBnTE_m = 0).

Address <TAUBn_base0> + 264_H

Initial value 0000_H

This register is initialized by any reset source.

15	14	13	12	11	10	9	8	7	6	5	4	3	2	1	0
TAUBnRDM15	TAUBnRDM14	TAUBnRDM13	TAUBnRDM12	TAUBnRDM11	TAUBnRDM10	TAUBnRDM09	TAUBnRDM08	TAUBnRDM07	TAUBnRDM06	TAUBnRDM05	TAUBnRDM04	TAUBnRDM03	TAUBnRDM02	TAUBnRDM01	TAUBnRDM00
R/W	R/W	R/W	R/W	R/W	R/W	R/W	R/W	R/W	R/W	R/W	R/W	R/W	R/W	R/W	R/W

Table 13-142 Description of TAUBnRDM Register

Bit Position	Bit Name	Function
15 to 0	TAUBnRDMm	Selects the timing for generating a simultaneous rewrite trigger signal. 0: When the master channel counter starts to count 1: At the peak of cycle of triangular wave These bit settings are applied only when TAUBnRDE.TAUBnRDE _m = 1 and TAUBnRDS.TAUBnRDS _m = 0.

(4) TAUBnRDC - TAUBn channel reload data control register

This register specifies a channel which generates an INTTAUBnIm signal to trigger simultaneous rewrite.

Access Readable/writable in 16-bit units. Writable only while the counter is stopped (TAUBnTE.TAUBnTE_m = 0).

Address <TAUBn_base0> + 26C_H

Initial value 0000_H

This register is initialized by any reset source.

15	14	13	12	11	10	9	8	7	6	5	4	3	2	1	0
TAUBnRDC15	TAUBnRDC14	TAUBnRDC13	TAUBnRDC12	TAUBnRDC11	TAUBnRDC10	TAUBnRDC09	TAUBnRDC08	TAUBnRDC07	TAUBnRDC06	TAUBnRDC05	TAUBnRDC04	TAUBnRDC03	TAUBnRDC02	TAUBnRDC01	TAUBnRDC00
R/W	R/W	R/W	R/W	R/W	R/W	R/W	R/W	R/W	R/W	R/W	R/W	R/W	R/W	R/W	R/W

Table 13-143 Description of TAUBnRDC Register

Bit Position	Bit Name	Function
15 to 0	TAUBnRDCm	Specifies whether the channel generates a simultaneous rewrite trigger signal or not. 0: Not operate as a simultaneous rewrite trigger channel. 1: Operates as a simultaneous rewrite trigger channel. These bit settings are applied only when TAUBnRDS.TAUBnRDS _m = 1.

(5) TAUBnRDT - TAUBn channel reload data trigger register

This register triggers a simultaneous rewrite pending state.

Access Writable in 16-bit units. This value is always read as 0000_H.

Address <TAUBn_base1> + 44_H

Initial value 0000_H

This register is initialized by any reset source.

15	14	13	12	11	10	9	8	7	6	5	4	3	2	1	0
TAUBnRDT	TAUBnRDT	TAUBnRDT	TAUBnRDT	TAUBnRDT	TAUBnRDT	TAUBnRDT	TAUBnRDT	TAUBnRDT	TAUBnRDT	TAUBnRDT	TAUBnRDT	TAUBnRDT	TAUBnRDT	TAUBnRDT	TAUBnRDT
15	14	13	12	11	10	09	08	07	06	05	04	03	02	01	00
W	W	W	W	W	W	W	W	W	W	W	W	W	W	W	W

Table 13-144 Description of TAUBnRDT Register

Bit Position	Bit Name	Function
15 to 0	TAUBnRDTm	Triggers a simultaneous rewrite pending state. 0: Invalid (Setting 0 does not trigger the simultaneous rewrite pending state) 1: Triggers a simultaneous rewrite pending state. The simultaneous rewrite pending flag (TAUBnRSF.TAUBnRSFm) is set to 1. The system waits for a simultaneous rewrite trigger. These bit settings are applied when TAUBnRDE.TAUBnRDEm = 1.

(6) TAUBnRSF - TAUBn channel reload status register

This flag register indicates simultaneous rewrite status.

Access Readable in 16-bit units.

Address <TAUBn_base1> + 48_H

Initial value 0000_H

This register is initialized by any reset source.

15	14	13	12	11	10	9	8	7	6	5	4	3	2	1	0
TAUBnRSF15	TAUBnRSF14	TAUBnRSF13	TAUBnRSF12	TAUBnRSF11	TAUBnRSF10	TAUBnRSF09	TAUBnRSF08	TAUBnRSF07	TAUBnRSF06	TAUBnRSF05	TAUBnRSF04	TAUBnRSF03	TAUBnRSF02	TAUBnRSF01	TAUBnRSF00
R	R	R	R	R	R	R	R	R	R	R	R	R	R	R	R

Table 13-145 Description of TAUBnRSF Register

Bit Position	Bit Name	Function
15 to 0	TAUBnRSFm	Indicates simultaneous rewrite status. 0: Indicates that a simultaneous rewrite trigger has started simultaneous rewrite. 1: Indicates that simultaneous rewrite is in the pending state (TAUBnRDT.TAUBnRDTm = 1).

Section 14 Timer Array Unit J (TAUJ)

This section provides general description of the timer array unit J (TAUJ).

The first part of this section describes all this product specific properties, such as instances, register base addresses, input/output signal names, etc. The subsequent parts describe the features that apply to all TAUJ implementations.

Caution Some channels of the timer array unit J may not be usable for a combination of channels or input/output selection for ports.

14.1 Features of TAUJ

Instances This product has following number of instances of the timer array unit J.

Table 14-1 Instances of TAUJ

TAUJ	
No. of instances	1
Name	TAUJ0

Instances index n Throughout this section, the individual instances of a timer array unit J is identified by the index "n" (n = 0), such as the TAUJn channel output mode register (TAUJnTOM).

Channel index m The timer array unit J has 4 channels. Throughout this section, the individual channels are identified by the index "m" (m = 0 to 3), thus a certain channel is denoted as CHm.
The even numbered channels (m = 0, 2) are denoted as CHm_even.
The odd numbered channels (m = 1, 3) are denoted as CHm_odd.

Register addresses All TAUJn register addresses are given as address offsets to the individual base addresses <TAUJn_base0> and <TAUJn_base1>.
The register base addresses <TAUJn_base0> and <TAUJn_base1> of each TAUJn are listed in the following table.

Table 14-2 Register Base Addresses <TAUJn_base0> and <TAUJn_base1>

TAUJn	<TAUJn_base0> Address	<TAUJn_base1> Address
TAUJ0	FF81 1000 _H	FFFF C200 _H

Clock supply The timer array unit J provides one clock input.

Table 14-3 TAUJn Clock Supply

TAUJn	Clock	Connected to
TAUJ0	PCLK	Clock controller

Interrupts and DMA The time array unit J can generate the following interrupt requests and DMA requests.

Table 14-4 TAUJn Interrupt and DMA Requests

TAUJn Signals	Function	Connected to
INTTAUJ0I0-INTTAUJ0I3	Channels 0 to 3 interrupt	Interrupt Controllers INTTAUJ0I0 to INTTAUJ0I3 DMA Controller triggers 19 to 22

I/O signals The I/O signals of the timer array unit J are listed in the following table.

Table 14-5 TAUJn I/O Signals

TAUJ Signal	Function	Connected to
TAUJnTTINm	Channel m input	Port TAUJnIm
TAUJnTTOUTm	Channel m output	Port TAUJnOm
TAUJnTSSTm	Simultaneous start trigger input	PIC Simultaneous timer start trigger function

TAUJn interrupt and I/O signals are shown below.

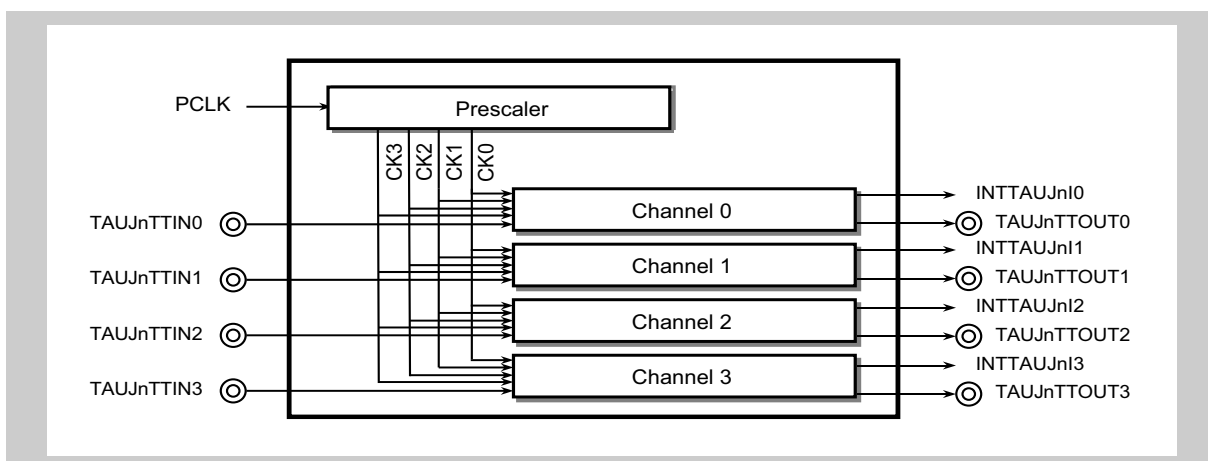

Figure 14-1 TAUJ I/O and Interrupt Signals

14.2 Functional Overview

Features summary The TAUJ has the following functions.

- 4 channels
- 32-bit counter and 32-bit data register per channel
- Independent channel operation
- Synchronous channel operation (master and slave operations)
- Generation of different types of output signals
- Counter can be triggered by external signals
- Interrupt generation

Caution The timing diagrams shown in this section are operation timing images. To the timer input, delay time is added. For details, see Section 14.11, TAUJnTTINm Edge Detection.

The following figure shows the main components of the TAUJ.

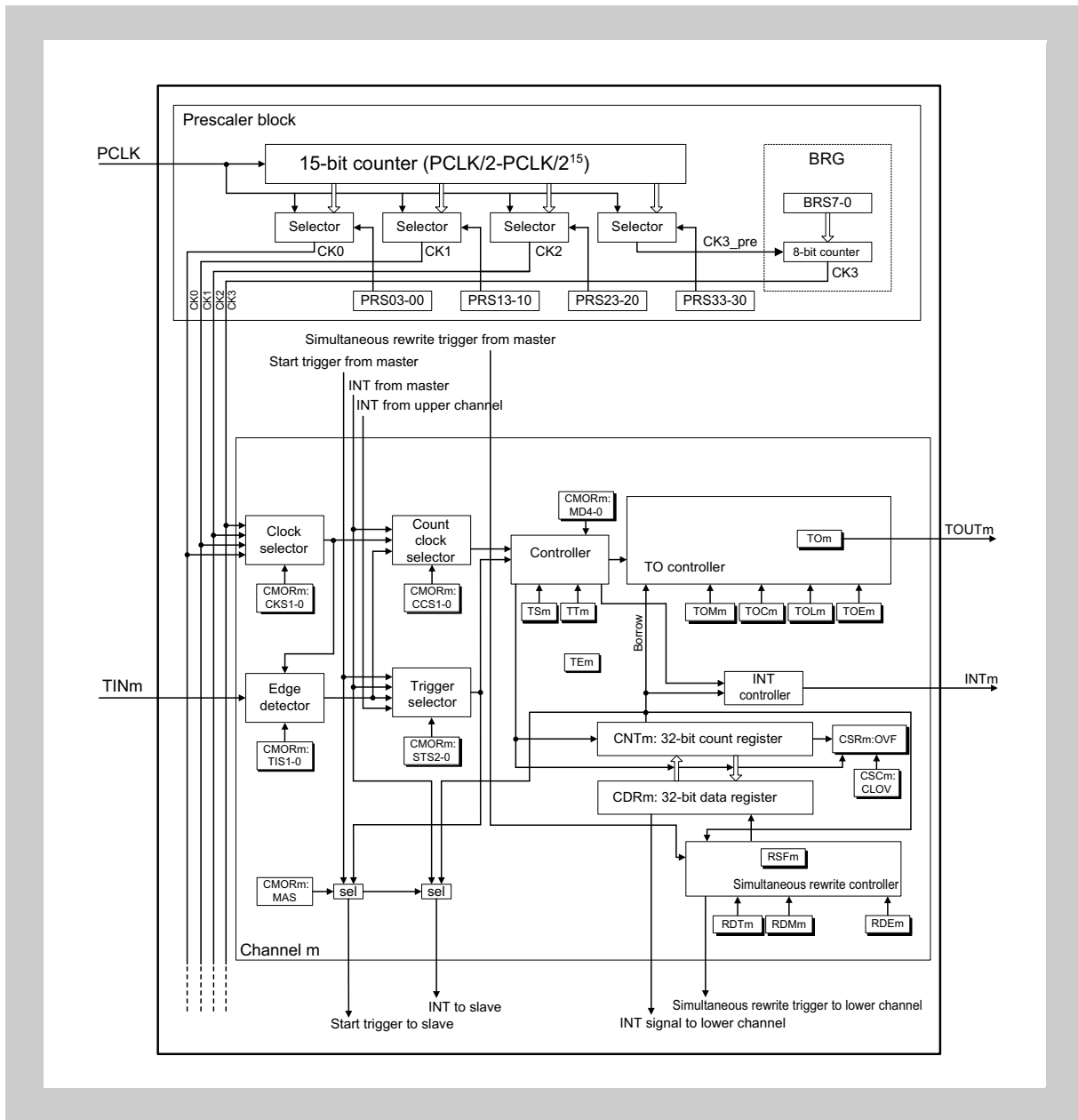

Figure 14-2 Block Diagram of TAUJ

"TAUJn" has been omitted from the register names for the sake of clarity in the above block diagram.

14.2.1 Terms

In this section, the following terms are used.

- **Independent/synchronous channel operation**

Independent or synchronous channel operation describes the dependency of channels on each other.

- If a channel operates independently of all other channels, this is called independent channel operation.
- If a channel operates depending on other channels, this is called synchronous channel operation.

- **Channel group**

In synchronous channel operation, all channels that depend on each other are referred to as a "channel group".

A channel group has one master channel and one or more slave channels.

- **Operating mode**

An operating mode can be selected for every channel m . The operating mode defines the basic operation and features of a channel.

In synchronous channel operation, every channel in the channel group can operate in a different operating mode.

Examples are "capture mode" and "interval timer mode".

- **Channel output mode**

The channel output mode defines the operation of $TAUJnTTOUTm$ of:

- a single channel (independent output operation) or
- all channels in a channel group (synchronous output operation).

Independent channel output mode 1 is a channel output mode.

- **Channel operation function**

The channel operation function defines the complete function and all features of:

- a single channel (independent channel operation) or
- all channels in a channel group (synchronous channel operation).

- **Upper/lower channel**

A channel can be referred to as an "upper" or "lower" channel as defined below.

- Upper channel: Channel with a smaller channel number
- Lower channel: Channel with a larger channel number

For instance, as to channel 2, channel 1 is an upper channel and channel 3 is a lower channel.

14.3 Functional Description

The timer array unit J is used to perform various count or timer operations and to output a signal which depends on the result of the operation. It contains one prescaler block for count clock generation and 4 channels, each equipped with a 32-bit counter TAUJnCNTm and a 32-bit data register TAUJnCDRm to hold the count start value or compare value.

It also contains several control and status registers.

Independent and synchronous operation Every channel can operate in two operating modes, either independently or in combination with other channels (synchronously), i.e. multiple channels depend on each other with one master and one or more slave channels.

When a channel is operated independently, its operating mode and functions are not affected by those of other channels. When a channel is operated synchronously, it is either a master or a slave. A master channel can have multiple slaves, and the state of one channel affects that of the other channels. For example, one channel can control count start timing or reset timing of another channel.

The following describes the functional blocks.

Prescaler block The prescaler block provides up to 4 clock signals (CK0 to CK3) that can be used as count clocks for all channels.

Prescaler outputs CK0 to CK2 are derived from PCLK by a configurable prescaler division factor of 2^0 to 2^{15} . The fourth prescaler output CK3 can be adjusted more precisely by an additional division factor that is not a power of 2.

Count clock selection For every channel, the count clock selector selects which of the following is used as the clock source.

- One of the prescaler outputs CK0 to CK3 (selected by the clock selector)
- INTTAUJnIm from master channel
- Valid edge of the TAUJnTTINm input signal

Controller The controller controls the main operations of the counter.

- Operating mode (selected by TAUJnCMORm.TAUJnMD[4:0] bits)
- Counter start enable (TAUJnTS.TAUJnTSm) and counter stop (TAUJnTT.TAUJnTTm)

When counter start is enabled, status flag TAUJnTE.TAUJnTEm is set.

Trigger selector Depending on the selected operating mode, the counter starts automatically when it is enabled (TAUJnTE.TAUJnTEm = 1), or it waits for an external start trigger signal. Any of the following signals can be used as the start trigger.

- Synchronous channel start trigger input TAUJnTSSTm
For details about simultaneous start between TAUJ units, see Section 24.4.1, Simultaneous Start Trigger Function.
- Valid edge of TAUJnTTINm input
- INTTAUJnIm from the master channel

Simultaneous rewrite controller Simultaneous rewrite control is a special function that can be used in synchronous operating modes. The data registers of all channels in a channel group can be rewritten at any time. The simultaneous rewrite controller ensures that new data register values of all channels become effective at the same time.

TAUJnTO controller The output control of every channel enables the generation of various output signals such as PWM signals.

14.3.1 Timer Operation Functions

This timer provides the following functions by operating individual channels independently or a combination of channels.

Table 14-6 TAUJ Operation Functions

Independent Operation Function	Synchronous Operation Function
Independent channel operation function	Synchronous channel operation function
Interval timer function	PWM output function
TAUJnTTINm input interval timer function	
Independent channel signal measurement function	
TAUJnTTINm input pulse interval measurement function	
TAUJnTTINm input signal width measurement function	
TAUJnTTINm input period count detection function	
Other independent channel functions	
TAUJnTTINm input position detection function	

14.4 General Operating Procedure

The following lists the general operation procedure for TAUJn.

After a reset release, the operation of each channel is stopped. When the clock supply is started, writing to each register is enabled. The control register of TAUJnTTOUTm is also initialized to output a low level.

1. Set the TAUJnTPS and TAUJnBRS registers to specify the clock frequency of CK0 to CK3.
2. Configure the desired TAUJn function:
 - Set the operating mode
 - Set the channel output mode
 - Set any other control bits
3. Enable the counter by setting the TAUJnTS.TAUJnTSM bit to 1.

The counter starts counting immediately or when an appropriate trigger is detected, depending on the bit settings.
4. If desired, and if possible for the configured function, stop the counter or perform a forced restart operation.
5. Stop the function by setting the TAUJnTT.TAUJnTTm bit to 1.

Note For details about necessary control bits and the operation of each function, see Section 14.12, Independent Channel Operation Functions, and Section 14.13, Synchronous Channel Functions.

14.5 Operating Modes

The TAUJ contains seven operating modes.

One operating mode can be set for each channel. It is specified using the TAUJnCMORm.TAUJnMD[4:0] bits.

Note Depending on the operation functions, some of the registers and bits have fixed values and the other can be set by the user.

For the values of registers and bits, see the sections of the corresponding operation functions.

14.6 Concepts of Synchronous Channel Operation

In synchronous channel operation, multiple channels depend on each other, or are affected by changes in other channels. Therefore, several rules apply to the use of synchronous channel functions. These rules are detailed in Section 14.6.1, Rules.

Two special features for synchronous channel operation are detailed in the following parts.

- Section 14.6.2, Simultaneous Start and Stop of Synchronous Channel Counters
- Section 14.7, Simultaneous Rewrite

14.6.1 Rules

Number of master and slave channels

- Only even channels (CH0, CH2) can be set as master channels. Any channel apart from CH0 can be set as a slave channel.
- Only channels lower than the master channel can be set as slave channels, and several slave channels can be set for one master channel.
Example: If CH2 is a master channel, CH3 can be set as slave channel.
- If two master channels are used, slave channels cannot cross the master.
Example: If CH0 and CH2 are master channels, CH1 can be set as slave channels for CH0, but CH3 cannot.

Count clock

- The same count clock should be set for the master channel and the slave channels synchronizing to the master channel. This is achieved by setting the same value in the TAUJnCMORM.TAUJnCKS[1:0] bits of the master and slave channels.

The basic concepts of master/slave usage and count clocks are illustrated in the following figure.

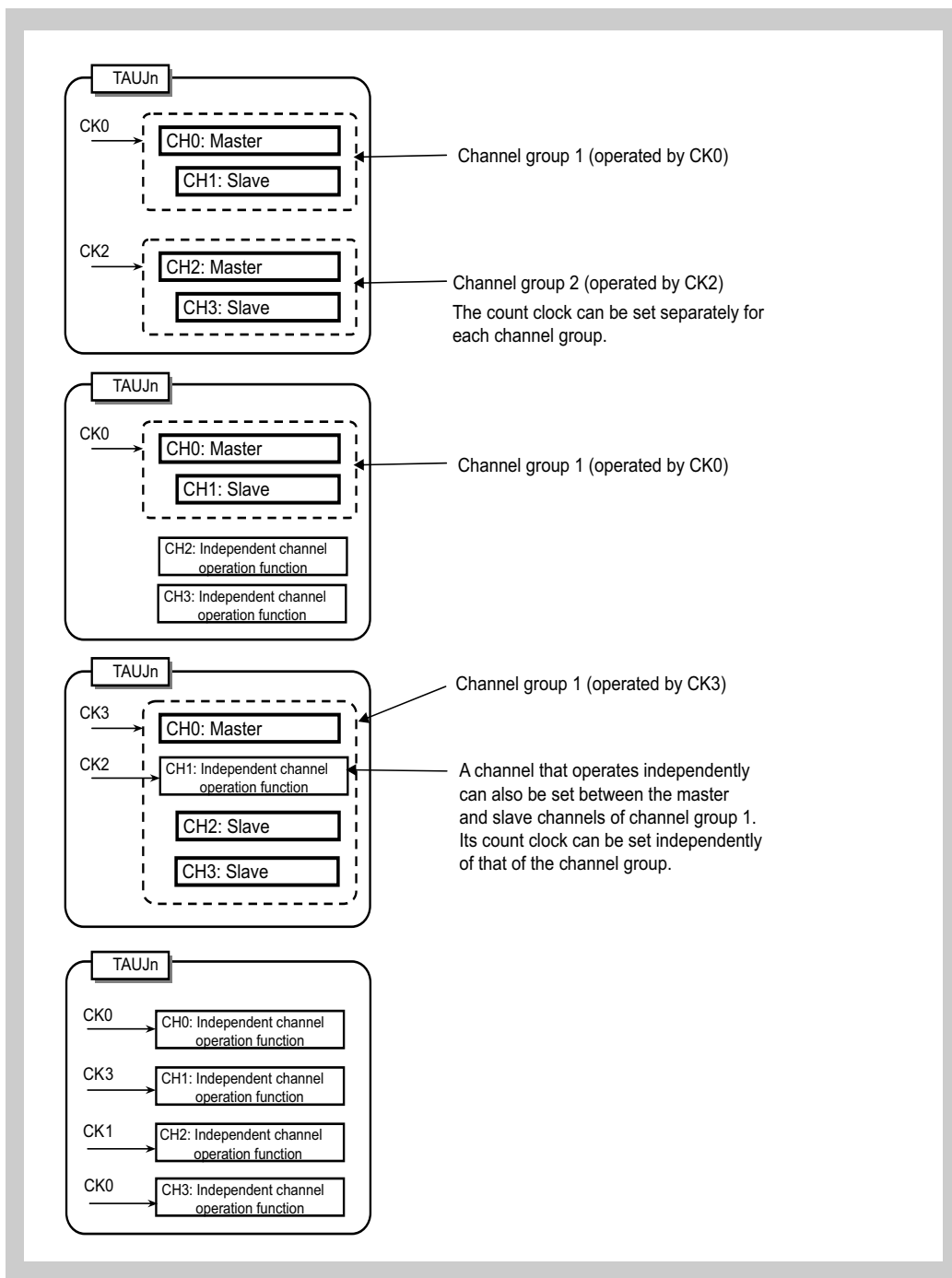

Figure 14-3 Grouping of Channels and Assignment of Count Clocks

Control trigger signals of master and slave channels

- Master channels can send a control signal to slave channels.
- Slave channels can use the control trigger signal sent from the master channels but cannot send their own control trigger signals to the lower channels.
- A master channel cannot use the control trigger signal sent from an upper master channel.

14.6.2 Simultaneous Start and Stop of Synchronous Channel Counters

Channels that are operated synchronously can be started and stopped simultaneously, both within a TAUJ unit and between TAUJ units.

(1) Simultaneous start and stop within a TAUJ unit

- To simultaneously start synchronized channels, the TAUJnTS.TAUJnTSM bits of the channels should be set at the same time.
- To simultaneously stop synchronized channels, the TAUJnTT.TAUJnTTM bits of the channels should be set at the same time.

Setting 1 in the TAUJnTS.TAUJnTSM bits sets the corresponding TAUJnTE.TAUJnTEM bits to 1, enabling counting. The count start timing of the counter depends on the operating mode.

(2) Simultaneous start between TAUJ units

Counters in different TAUJ units can also be started simultaneously if the corresponding counters are enabled before receiving the simultaneous trigger signal.

For details about how to make a simultaneous start between TAUJ units, see Section 24.4.1, Simultaneous Start Trigger Function.

14.7 Simultaneous Rewrite

14.7.1 Overview

Simultaneous rewrite describes the ability to change the compare/start value and the output logic of multiple channels at the same time.

The corresponding data and control registers (TAUJnCDRm and TAUJnTOLm) can be written at any time. The new value does not affect the counter operation or the output signal until simultaneous rewrite is triggered.

Simultaneous rewrite can be triggered by the counter on the master channel reaching a certain value.

The following table shows the settings for simultaneous rewrite (TAUJnRDM.TAUJnRDMM = 0).

Table 14-7 Simultaneous Rewrite Settings

Method	Simultaneous Rewrite Trigger Timing	TAUJnRDE.TAUJnRDEm
—	No simultaneous rewrite	0
A	The master channel restarts/starts counting	1

14.7.2 How to Control Simultaneous Rewrite

The following figure shows the general procedure for simultaneous rewrite. The three main blocks (Initial settings, Start counter & count operation, and Simultaneous rewrite) are explained afterwards.

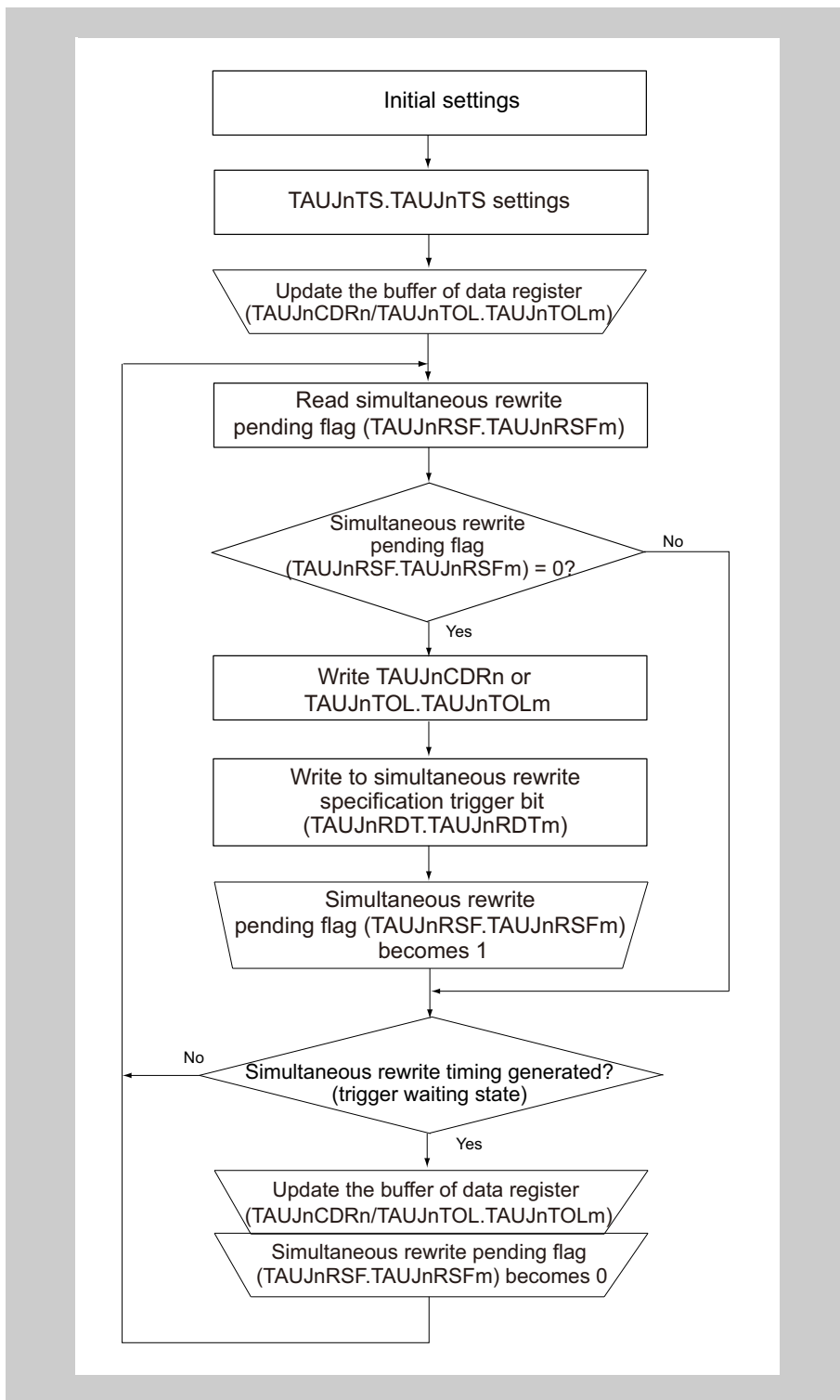

Figure 14-4 General Procedure for Simultaneous Rewrite

(1) Initial settings

- To enable simultaneous rewrite in channel m, set $\text{TAUJnRDE.TAUJnRDEm} = 1$

(2) Start counter and count operation

- To start all the TAUJnCNTm counters in the channel group, set the corresponding TAUJnTS.TAUJnTSm bits to 1. $\text{TAUJnTOL.TAUJnTOLm}$ and the values in the data registers (TAUJnCDRm) are loaded into the corresponding $\text{TAUJnTOL.TAUJnTOLm}$ buffer ($\text{TAUJnTOL.TAUJnTOLm}$ buf) and data buffer registers (TAUJnCDRm buf) and the counters start.
- Setting the reload data trigger bit ($\text{TAUJnRDT.TAUJnRDTm}$) to 1 sets the reload flag ($\text{TAUJnRSF.TAUJnRSFm}$) to 1, enabling simultaneous rewrite. $\text{TAUJnRSF.TAUJnRSFm}$ remains set to 1 until simultaneous rewrite is completed.
- When a specified trigger for simultaneous rewrite is detected, the $\text{TAUJnRSF.TAUJnRSFm}$ bit is checked to see if simultaneous rewrite is enabled ($\text{TAUJnRSF.TAUJnRSFm} = 1$). If enabled, simultaneous rewrite is carried out. Otherwise simultaneous rewrite is not carried out and the system waits for detection of the next simultaneous rewrite trigger.

(3) Simultaneous rewrite

- When the simultaneous rewrite trigger is detected and simultaneous rewrite is enabled ($\text{TAUJnRSF.TAUJnRSFm} = 1$), the current values of the data registers are copied to their buffers. These values are then loaded into the corresponding counters and the values are applied the next time the counter starts or restarts.
- When the simultaneous rewrite is completed, the $\text{TAUJnRSF.TAUJnRSFm}$ bit is set to 0, and the system awaits the next simultaneous rewrite trigger.

14.7.3 Other General Rules for Simultaneous Rewrite

The following rules also apply.

- $\text{TAUJnRDE.TAUJnRDEm}$ and $\text{TAUJnRDM.TAUJnRDMm}$ cannot be changed while the counter is in operation ($\text{TAUJnTE.TAUJnTEm} = 1$).
- $\text{TAUJnTOL.TAUJnTOLm}$ can be rewritten only during operation using the PWM output function. For all other functions, $\text{TAUJnTOL.TAUJnTOLm}$ should be written before the counter starts. If it is rewritten while any other function is used, TAUJnTTOUTm outputs an invalid wave.

14.7.4 Simultaneous Rewrite Procedure

Simultaneous rewrite is executed when the master channel starts or restarts counting.

The simultaneous rewrite procedure is described in the following figure.

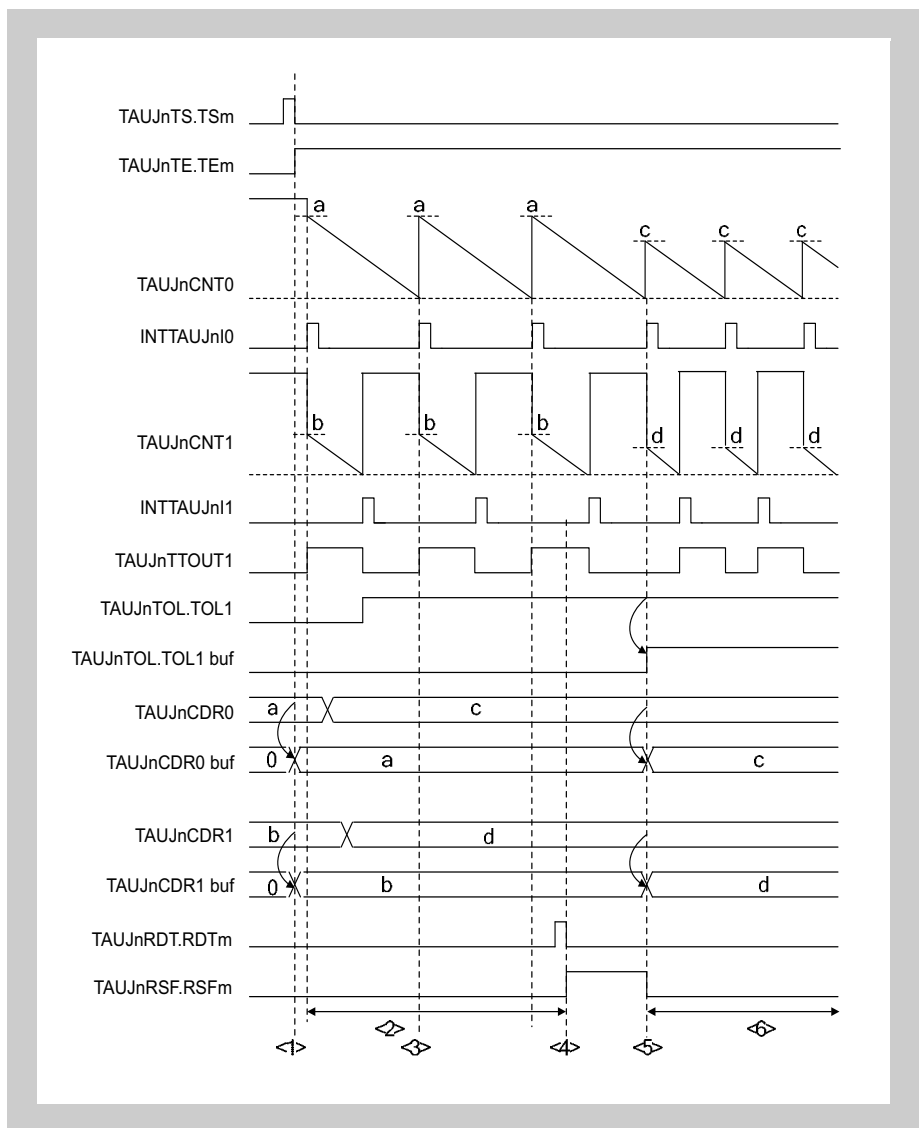

Figure 14-5 Simultaneous Rewrite When the Master Channel Starts/Restarts to Count

Setting

- CH0 is a master channel used to count down, and CH1 represents an arbitrary slave channel. Simultaneous rewrite is applied when the master channel starts counting.

Description:

1. When $\text{TAUJnTS.TAUJnTSM} = 1$ is set, the value of TAUJnCDRm is copied to the TAUJnCDRm buffer and the value of $\text{TAUJnTOL.TAUJnTOLm}$ is copied to the $\text{TAUJnTOL.TAUJnTOLm}$ buffer.
2. The TAUJnCDRm and $\text{TAUJnTOL.TAUJnTOLm}$ registers can be written at any time.
3. CH0 restarts counting, but simultaneous rewrite does not occur because it is disabled ($\text{TAUJnRSF.TAUJnRSFm} = 0$).
4. The reload data trigger bit ($\text{TAUJnRDT.TAUJnRDTm}$) is set to 1 which sets the status flag ($\text{TAUJnRSF.TAUJnRSFm} = 1$), enabling simultaneous rewrite.
5. Simultaneous rewrite is triggered when CH0 restarts counting, because simultaneous rewrite is enabled. The TAUJnCDRm value is loaded into the TAUJnCDRm buffer and the $\text{TAUJnTOL.TAUJnTOLm}$ value is loaded into the $\text{TAUJnTOL.TAUJnTOLm}$ buffer.
6. The counter counts down and awaits the next simultaneous rewrite trigger. The values of TAUJnCDRm and $\text{TAUJnTOL.TAUJnTOLm}$ can be changed again.

14.8 Channel Output Modes

The output of the TAUJnTTOUTm pin can be controlled in two ways, the latter of which can be further split into individual modes.

- Control by software (TAUJnTOE.TAUJnTOEm = 0)

When controlled by software, the value written in the output register bit (TAUJnTO.TAUJnTOM) is output through the output pin (TAUJnTTOUTm).

- Control by TAUJ signals (TAUJnTOE.TAUJnTOEm = 1)

When controlled by TAUJ signals, the output level of TAUJnTTOUTm is set or reset or toggled by internal signals. The value of TAUJnTO.TAUJnTOM is updated accordingly to reflect the value of TAUJnTTOUTm.

- Independent control (TAUJnTOM.TAUJnTOMm = 0)

In independent operation, the output of the TAUJnTTOUTm pin is only affected by settings of channel m. Therefore, independent channel operation should be selected (TAUJnTOM.TAUJnTOMm = 0).

- Synchronous control (TAUJnTOM.TAUJnTOMm = 1)

In synchronous operation, the output of the TAUJnTTOUTm pin is affected by settings of channel m and those of other channels. Therefore, synchronous channel operation should be selected for all synchronizing channels (TAUJnTOM.TAUJnTOMm = 1).

The TAUJnTO.TAUJnTOM bit can always be read to determine the current value of TAUJnTTOUTm, regardless of whether the pin is controlled by software or operated independently or synchronously.

Control bits The settings of the control bits required to select a specific channel output mode are listed in Table 14-8, Channel Output Modes.

The channel output modes are described in detail in:

- Section 14.8.2, Channel Output Modes Controlled Independently by TAUJn Signals
- Section 14.8.3, Channel Output Modes Controlled Synchronously by TAUJn Signals

Batch operation of TAUJnTOM bit The TAUJnTOE.TAUJnTOEm bit is used to control whether settings are to be reflected to the TAUJnTOM bit or not.

During the write operation to the TAUJnTO register, the setting of TAUJnTOM is written only to the bit (channel) for which TAUJnTOE.TAUJnTOEm = 0 is set. To the bit (channel) for which TAUJnTOE.TAUJnTOEm = 1 is set, the setting of TAUJnTOM is not reflected.

Note The TAUJnTO.TAUJnTOM bit is assigned so that the bit number corresponds to the channel number.

Output logic Positive logic or inverted logic of the output is specified by control bit TAUJnTOL.TAUJnTOLm.

The value of the TAUJnTOL.TAUJnTOLm bit should be set before the counter is started. It can be changed during operation only with PWM output function. If TAUJnTOL.TAUJnTOLm is changed after the start of counter operation, an invalid TAUJnTTOUTm signal is output.

See Section 14.7, Simultaneous Rewrite.

The channel output modes and the channel output control bits are listed in the following table (TAUJnTOC.TAUJnTOCm = 0).

Table 14-8 Channel Output Modes

Channel Output Mode	TAUJnTOE. TAUJnTOEm	TAUJnTOM. TAUJnTOMm
By software		
Independent channel output mode controlled by software	0	X
By TAUJ signals, independently		
Independent channel output mode 1	1	0
By TAUJ signals, synchronously		
Synchronous channel output mode 1	1	1

Caution 1. The combinations not listed in this table are forbidden.

Caution 2. The bit marked with an "x" can be set to any value.

Caution 3. The following bits should not be changed during count operation (TAUJnTE.TAUJnTEm = 1).

- TAUJnTOE.TAUJnTOEm
- TAUJnTOM.TAUJnTOMm
- TAUJnTOC.TAUJnTOCm

14.8.1 General Procedure for Specifying a Channel Output Mode

This section describes the general procedures for specifying a TAUJnTTOUTm channel output mode. The prerequisite is that a timer output operation is disabled (TAUJnTOE.TAUJnTOEm = 0).

1. Set TAUJnTO.TAUJnTOm to specify an initial level of the TAUJnTTOUTm output.
2. Set channel output mode according to Table 14-8, Channel Output Modes, and set the output logic using the TAUJnTOL.TAUJnTOLm bit.
3. Start the counter (TAUJnTS.TAUJnTSm = 1).

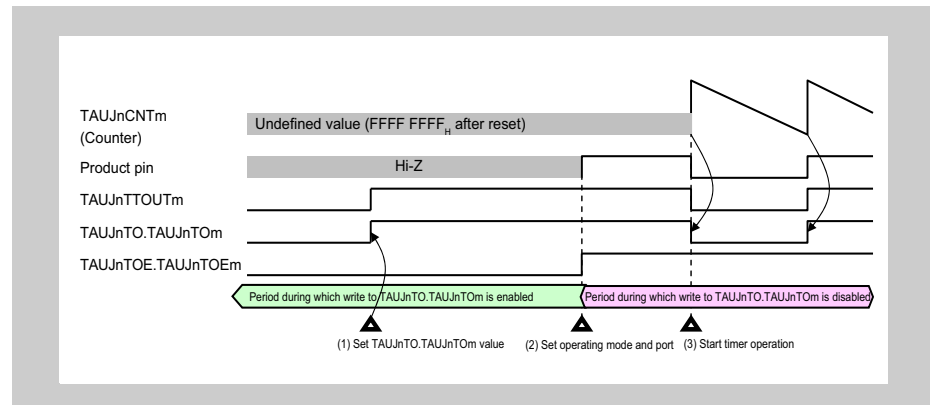

Figure 14-6 General Procedure for Specifying a TAUJnTTOUTm Channel Output Mode

14.8.2 Channel Output Modes Controlled Independently by TAUJn Signals

This section lists the channel output modes that are controlled independently by TAUJn signals. The control bits used to specify a mode are listed in Table 14-8, Channel Output Modes.

(1) Independent channel output mode 1

Set/reset conditions In this output mode, TAUJnTTOUTm toggles when INTTAUJnIm is detected. The value of TAUJnTOL.TAUJnTOLm is ignored.

Prerequisites There are no prerequisites other than those shown in Table 14-8, Channel Output Modes.

14.8.3 Channel Output Modes Controlled Synchronously by TAUJn Signals

This section lists the channel output modes that are controlled synchronously by TAUJn signals. The control bits used to specify a mode are listed in Table 14-8, Channel Output Modes.

(1) Synchronous channel output mode 1

Set/reset conditions In this output mode, INTTAUJnIm of the master channel serves as the set signal and INTTAUJnIm of the slave channel as the reset signal. If INTTAUJnIm of the master channel and INTTAUJnIm of the slave channel are generated at the same time, INTTAUJnIm of the slave channel (reset signal) has priority over INTTAUJnIm (set signal) of the master channel (the master channel is ignored).

Prerequisites There are no prerequisites other than those shown in Table 14-8, Channel Output Modes.

14.9 Start Timing of Operating Modes

This section describes the counter operation start timing after TAUJnTS.TAUJnTsm is set to 1.

The value of the data register (TAUJnCDRm register) and whether or not an interrupt occurs depend on mode and register settings.

Caution The count start timing described in this section is for your reference. Actually, the count start timing depends on count clock timing.

14.9.1 Interval Timer Mode and Capture Mode

The counter starts operating with the next count clock after TAUJnTS.TAUJnTsm is set to 1. The value of data register is also loaded when the counter starts.

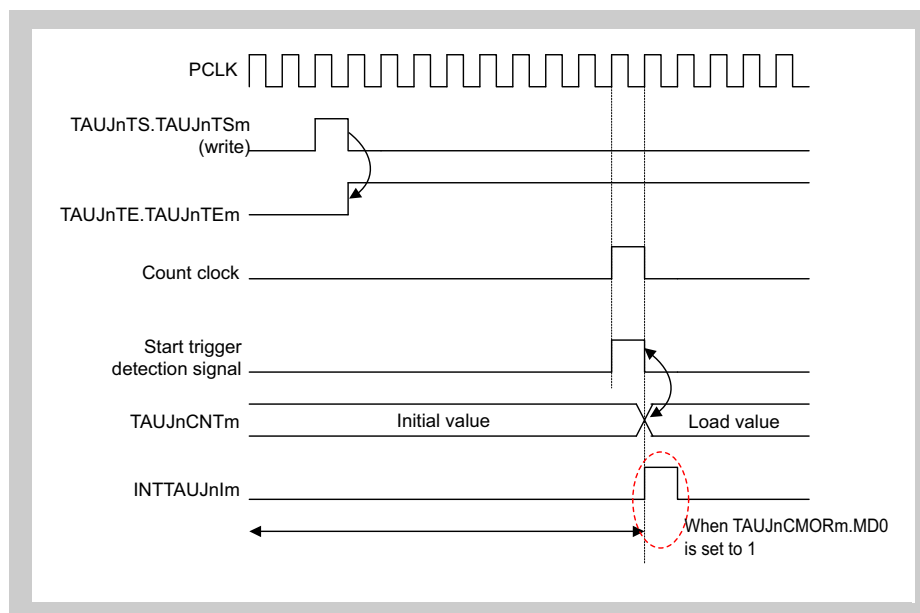

Figure 14-7 Start Timing in Interval Timer Mode and Capture Mode

14.9.2 Other Operating Modes

In other operating modes, the counter operation is triggered only by detection of a valid TAUJnTTINm edge. The value of data register is also loaded when the counter starts. The count clock cycles, which are unrelated to counter operation start, determine the frequency with which all operations take place.

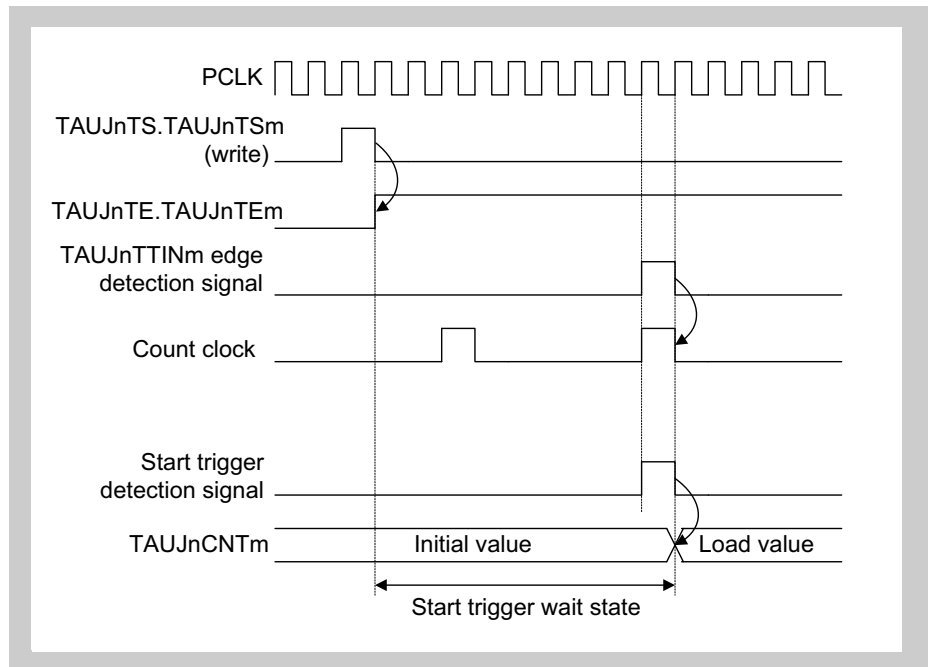

Figure 14-8 Count Start Timing in Other Operating Modes

14.10 TAUJnTTOUTm Output and INTTAUJnIm Generation When Counter Starts or Restarts

When the counter starts, it is possible to specify whether an INTTAUJnIm is generated using the TAUJnCMORm.TAUJnMD0 bit. The effect of the bit depends on the selected mode, as shown in the following table. The effects of INTTAUJnIm on TAUJnTTOUTm depend on the selected channel operation function.

Table 14-9 Effect of TAUJnCMORm.TAUJnMD0 Bit on Generation of INTTAUJnIm When Counter Is Triggered

Mode	TAUJnCMORm.TAUJnMD0 Bit	INTTAUJnIm Generated When Counter Starts/Restarts or TAUJnTTINm Input Signal Trigger Is Detected
Interval timer mode	0	Not generated
Capture mode	1	Generated
Count capture mode		
Capture & one-count mode	0	Not generated
Capture & gate count mode	0/1	Not generated, regardless of setting of TAUJnCMORm.TAUJnMD0 bit
One-count mode		

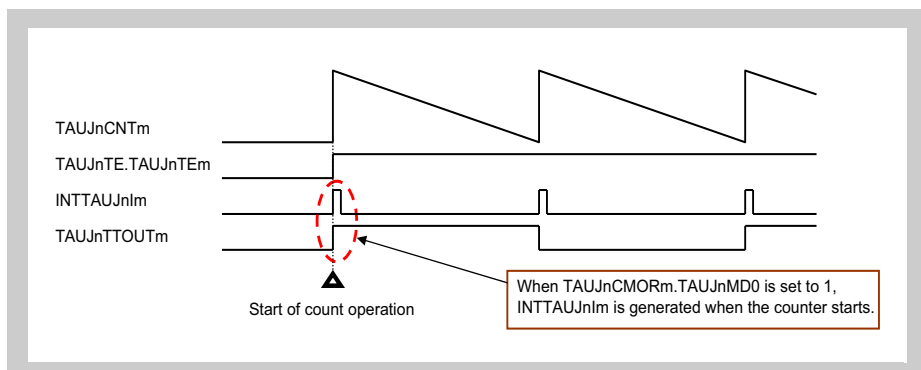

Figure 14-9 INTTAUJnIm Generated When Counter Starts

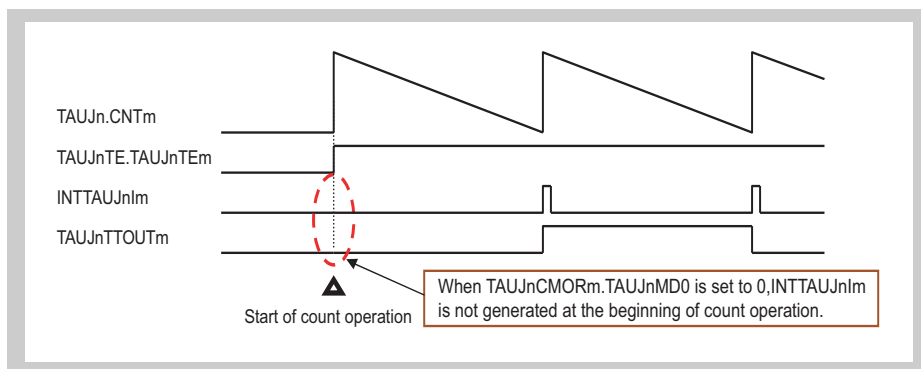

Figure 14-10 INTTAUJnIm Not Generated When Counter Starts

14.11 TAUJnTTINm Edge Detection

The TAUJnTTINm edge is detected at the rising edge of a sampling clock. A delay of one sampling clock cycle or less may occur.

The following figure shows when edge detection takes place.

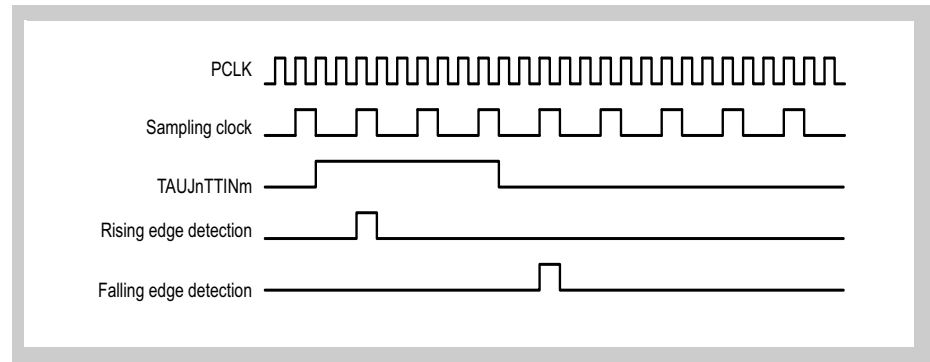

Figure 14-11 Basic Edge Detection Timing

Caution Figure 14-11, Basic Edge Detection Timing, shows an image of operation timing. In the actual operation, delay time occurs due to noise filter and synchronization circuit between the TAUJnIm pin and TAUJn.

- When the noise filter is used
Delay time at the noise filter + delay time in edge detection (maximum 1 sampling clock)
- When the noise filter is not used
Delay time at the synchronization circuit (maximum 2 PLCK) + delay time in edge detection (maximum 1 sampling clock)

14.12 Independent Channel Operation Functions

The following sections list the independent channel operation functions provided by the timer array unit J. For a general overview of independent channel operation, see Section 14.3, Functional Description.

14.12.1 Interval Timer Function

(1) Overview

- Summary** This function is used as a reference timer for generating timer interrupts (INTTAUJnIm) at regular intervals. When an interrupt is generated, the TAUJnTTOUTm signal toggles, resulting in a rectangular wave.
- Prerequisites**
- The operating mode should be set to interval timer mode. (See Table 14-10, TAUJnCMORm Settings for Interval Timer Function.)
 - The channel output mode should be set to independent channel output mode 1. (See Section 14.8, Channel Output Modes.)
- Functional description**
- The counter is started by setting the channel trigger bit (TAUJnTS.TAUJnTSM) to 1. This in turn sets TAUJnTE.TAUJnTEM = 1, enabling count operation. The current value of TAUJnCDRm is loaded into TAUJnCNTm and the counter starts to count down from this value.
- When the counter reaches 0000 0000_H, INTTAUJnIm is generated and the TAUJnTTOUTm signal toggles. Then the TAUJnCDRm value is loaded in TAUJnCNTm and the counter subsequently continues operation.
- The value of TAUJnCDRm can be rewritten at any time, and the changed value of TAUJnCDRm is applied the next time the counter starts to count down.
- The counter can be stopped by setting TAUJnTT.TAUJnTTM to 1, which in turn sets TAUJnTE.TAUJnTEM to 0. TAUJnCNTm and TAUJnTTOUTm stop but retain their values. The counter can be restarted by setting TAUJnTS.TAUJnTSM to 1. The counter can also be forcibly restarted without making a stop once by setting TAUJnTS.TAUJnTSM to 1 during operation.
- Conditions** If the TAUJnCMORm.TAUJnMD0 bit is set to 0, the first interrupt after a start or restart is not generated, and therefore TAUJnTTOUTm does not toggle. This results in an inverted TAUJnTTOUTm signal compared to when TAUJnCMORm.TAUJnMD0 is set to 1. For details, see Section 14.10, TAUJnTTOUTm Output and INTTAUJnIm Generation When Counter Starts or Restarts.
- (2) Equations**
- INTTAUJnIm cycle = Count clock cycle x (TAUJnCDRm + 1)
- TAUJnTTOUTm rectangular wave cycle = Count clock cycle x (TAUJnCDRm + 1) x 2

(3) Block diagram and general timing diagram

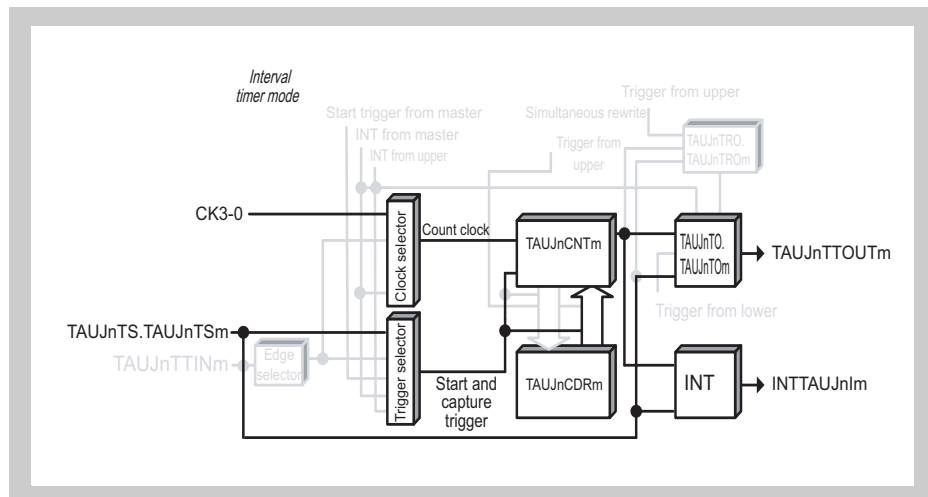

Figure 14-12 Block Diagram of Interval Timer Function

The following settings apply to the general timing diagram.

- INTTAUJnIm is generated at the beginning of operation. (TAUJnCMORm.TAUJnMD0 = 1)

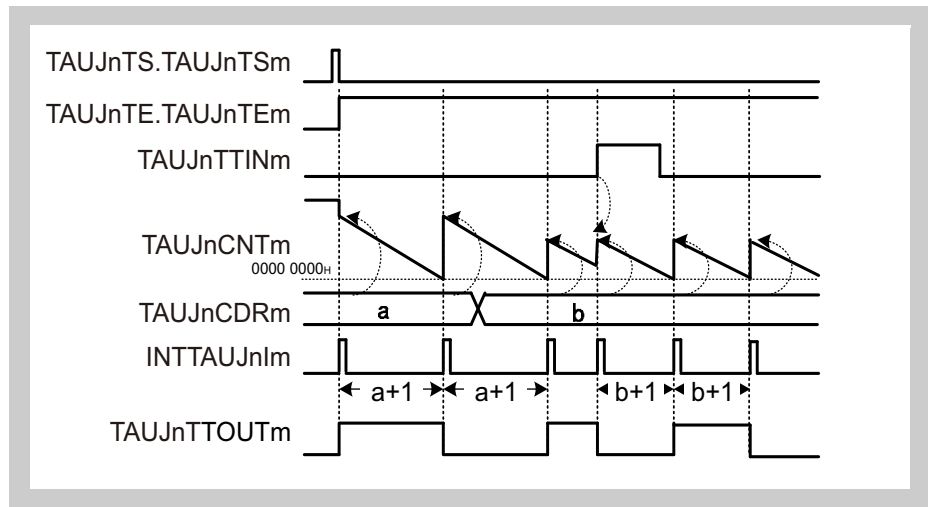

Figure 14-13 General Timing Diagram of Interval Timer Function

(4) Register settings

(a) TAUJnCMORM

15	14	13	12	11	10	9	8	7	6	5	4	3	2	1	0
TAUJnCKS [1:0]	TAUJnCCS [1:0]	TAUJnMAS	TAUJnSTS[2:0]			TAUJnCOS [1:0]		-	TAUJnMD[4:1]				TAUJnMD0		

Table 14-10 TAUJnCMORM Settings for Interval Timer Function

Bit Name	Setting
TAUJnCKS[1:0]	Selects the sampling clock 00: Prescaler output CK0 01: Prescaler output CK1 10: Prescaler output CK2 11: Prescaler output CK3
TAUJnCCS[1:0]	00: Sampling clock is used as a count clock
TAUJnMAS	0: Unused. Set to 0
TAUJnSTS[2:0]	000: Counter triggered by software
TAUJnCOS[1:0]	00: Unused. Set to 00
TAUJnMD[4:1]	0000: Interval Timer Mode
TAUJnMD0	0: INTTAUJnIm is not generated and TAUJnTTOUTm does not toggle at the beginning of operation 1: INTTAUJnIm is generated and TAUJnTTOUTm toggles at beginning or restart time of operation

(b) TAUJnCMURm

7	6	5	4	3	2	1	0
-						TAUJnTIS[1:0]	

Table 14-11 TAUJnCMURm Settings for Interval Timer Function

Bit Name	Setting
TAUJnTIS[1:0]	00: Unused. Set to 00

(c) Channel output mode**Table 14-12 Control Bit Settings for Independent Channel Output Mode 1**

Bit Name	Setting
TAUJnTOE.TAUJnTOEm	1: Enables independent channel output mode
TAUJnTO.TAUJnTOm	0: Low level 1: High level
TAUJnTOM.TAUJnTOMm	0: Independent channel output
TAUJnTOC.TAUJnTOCm	0: Operating mode 1 (Toggle mode if TAUJnTOM.TAUJnTOMm = 0)
TAUJnTOL.TAUJnTOLm	0: Positive logic

Note The channel output mode can also be set to channel output mode controlled by software by setting TAUJnTOE.TAUJnTOEm = 0. TAUJnTTOUTm can then be controlled independently of the interrupts. For details, see Section 14.8, Channel Output Modes.

(d) Simultaneous rewrite

The simultaneous rewrite registers (TAUJnRDE and TAUJnRDM) cannot be used with the Interval Timer Function. Therefore, these registers should be set to 0.

Table 14-13 Simultaneous Rewrite Settings for Interval Timer Function

Bit Name	Setting
TAUJnRDE.TAUJnRDEm	0: Disables simultaneous rewrite
TAUJnRDM.TAUJnRDMm	0: When simultaneous rewrite is disabled (TAUJnRDE.TAUJnRDEm = 0), set these bits to 0

(5) Operating procedure for Interval Timer Function

Table 14-14 Operating Procedure for Interval Timer Function

	Operation	TAUJn Status
Restart ↓	Initial channel setting Set the TAUJnCMORm and TAUJnCMURm registers as described in Table 14-10, TAUJnCMORm Settings for Interval Timer Function, and Table 14-11, TAUJnCMURm Settings for Interval Timer Function. Set the value of the TAUJnCDRm register. Set the channel output mode by setting the control bits as described in Table 14-12, Control Bit Settings for Independent Channel Output Mode 1.	Channel operation is stopped.
	Start operation Set TAUJnTS.TAUJnTSm to 1. TAUJnTS.TAUJnTSm is a trigger bit, which is automatically cleared to 0.	TAUJnTE.TAUJnTEm is set to 1 and the counter starts. TAUJnCDRm value is loaded in TAUJnCNTm. When TAUJnCMORm.TAUJnMD0 = 1, INTTAUJnIm is generated and TAUJnTTOUTm toggles.
	During operation The TAUJnCDRm register value can be changed at any time. The TAUJnCNTm register can be read at all times.	TAUJnCNTm counts down. When the counter reaches 0000 0000 _H : <ul style="list-style-type: none"> TAUJnCDRm value is loaded again in TAUJnCNTm and count operation continues. INTTAUJnIm is generated and TAUJnTTOUTm toggles.
	Stop operation Set TAUJnTT.TAUJnTTm to 1. TAUJnTT.TAUJnTTm is a trigger bit, which is automatically cleared to 0.	TAUJnTE.TAUJnTEm is cleared to 0 and the counter stops. TAUJnCNTm and TAUJnTTOUTm stop and retain their current values.

(6) Specific timing diagrams

(a) TAUJnCDRm = 0000 0000_H, count clock = PCLK/2

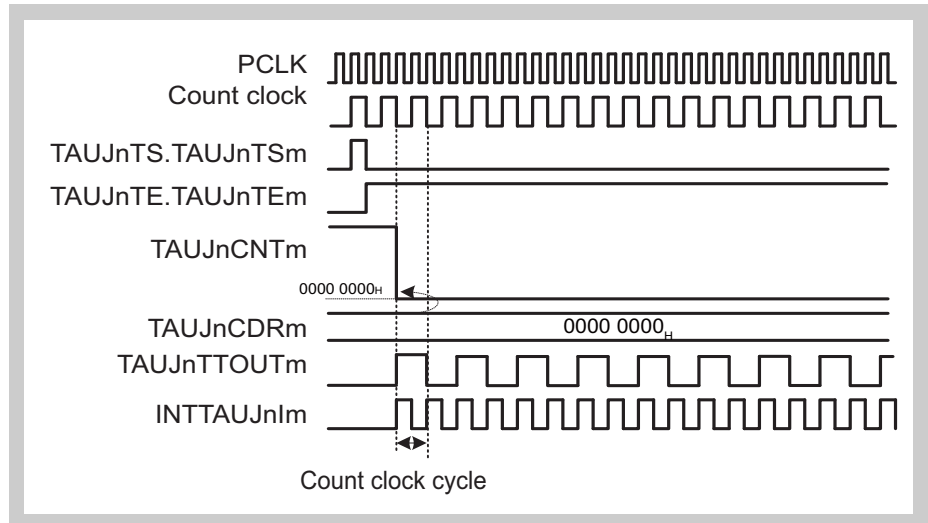

Figure 14-14 TAUJnCDRm = 0000 0000_H, Count Clock = PCLK/2

- If TAUJnCDRm = 0000 0000_H and the count clock = PCLK/2¹, the TAUJnCDRm value is loaded into TAUJnCNTm every count clock, meaning that TAUJnCNTm is always 0000 0000_H.
- INTTAUJnIm is generated every count clock, resulting in TAUJnTTOUTm toggling every count clock.

(b) TAUJnCDRm = 0000 0000_H, count clock = PCLK

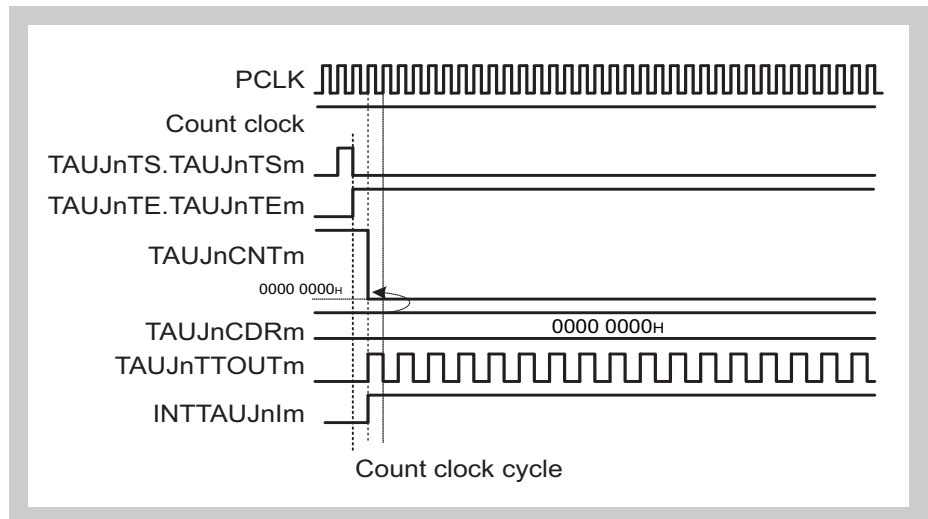
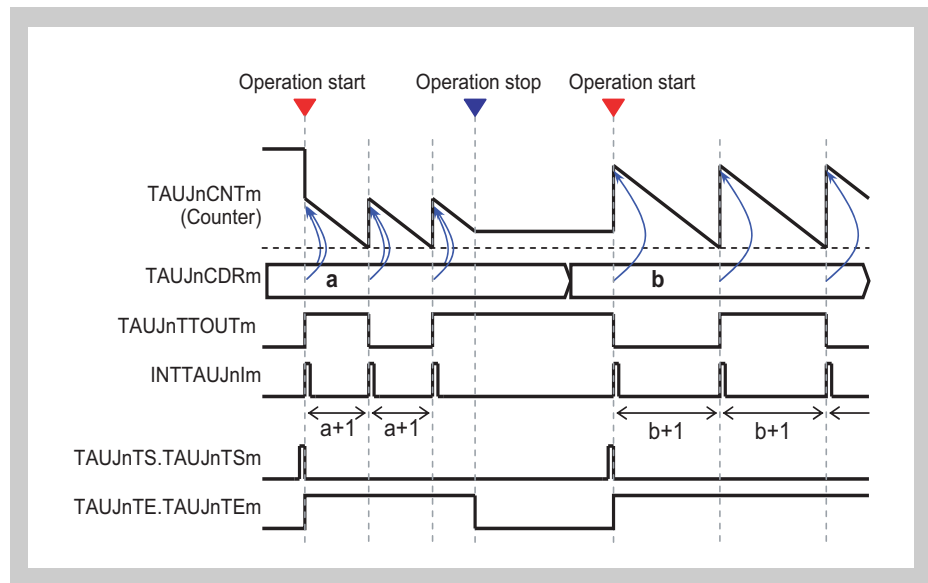
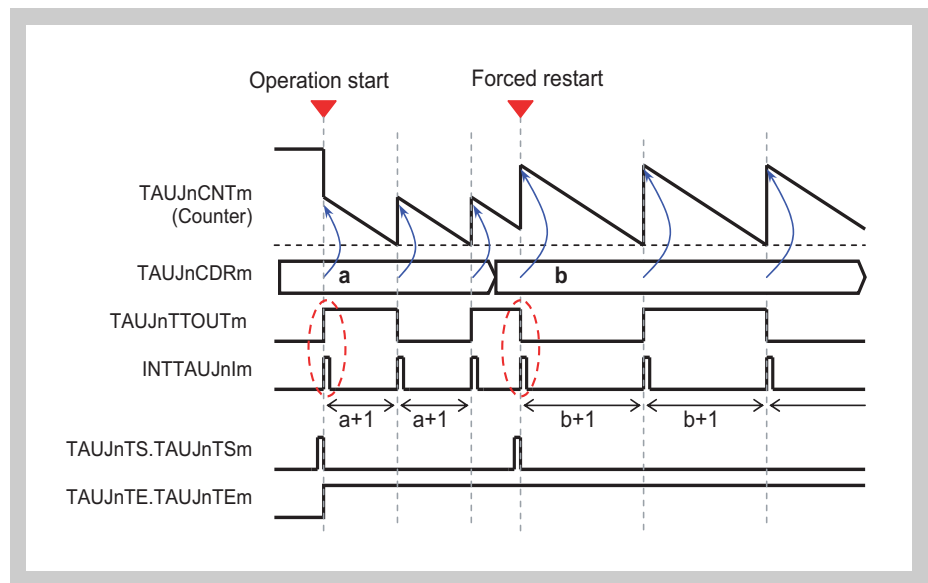

Figure 14-15 TAUJnCDRm = 0000 0000_H, Count Clock = PCLK

- If TAUJnCDRm = 0000 0000_H and the count clock = PCLK, the TAUJnCDRm value is loaded into TAUJnCNTm every PCLK clock, meaning that TAUJnCNTm is always 0000 0000_H.
- INTTAUJnIm is generated continuously, resulting in TAUJnTTOUTm toggling every PCLK clock.

(c) Operation stop and restart**Figure 14-16 Operation Stop and Restart (TAUJnCMORM.TAUJnMD0 = 1)**

- The counter can be stopped by setting TAUJnTT.TAUJnTTm to 1, which in turn sets TAUJnTE.TAUJnTEm to 0.
- TAUJnCNTm and TAUJnTTOUTm stop but retain their values.
- The counter can be restarted by setting TAUJnTS.TAUJnTSm to 1.

(d) Forced restart**Figure 14-17 Forced Restart Operation (TAUJnCMORM.TAUJnMD0 = 1)**

- The counter can be forcibly restarted (without stopping it first) by setting TAUJnTS.TAUJnTSm to 1 during operation.
- If the TAUJnCMORM.TAUJnMD0 bit is set to 1, the first interrupt after a start or restart is generated.

14.12.2 TAUJnTTINm Input Interval Timer Function

(1) Overview

Summary This function is used as a reference timer for generating timer interrupts (INTTAUJnIm) at regular intervals or when a valid TAUJnTTINm input edge is detected. When an interrupt is generated, the TAUJnTTOUTm signal toggles, resulting in a rectangular wave.

- Prerequisites**
- The operating mode should be set to interval timer mode. (See Table 14-15, TAUJnCMORm Settings for TAUJnTTINm Input Interval Timer Function.)
 - The channel output mode should be set to independent channel output mode 1. (See Section 14.8, Channel Output Modes.)

Functional description This function operates in the same manner as the interval timer function (see Section 14.12.1, Interval Timer Function), except that this function is restarted by a valid TAUJnTTINm input edge. The type of edge used as the trigger is specified using the TAUJnCMURm. TAUJnTIS[1:0] bits. Either rising edge, falling edge, or rising and falling edge can be selected.

(2) Equations

$$\text{INTTAUJnIm cycle} = \text{Count clock cycle} \times (\text{TAUJnCDRm} + 1)$$

$$\text{TAUJnTTOUTm rectangular wave cycle} = \text{Count clock cycle} \times (\text{TAUJnCDRm} + 1) \times 2$$

(3) Block diagram and general timing diagram

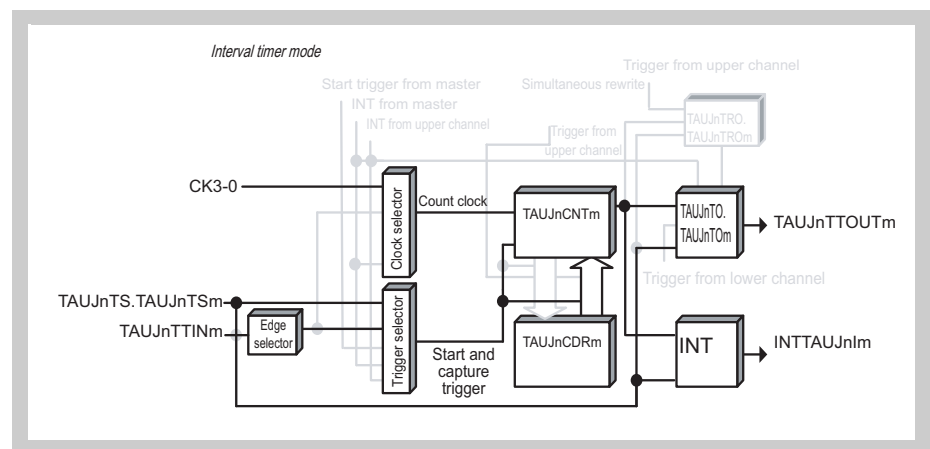

Figure 14-18 Block Diagram of TAUJnTTINm Input Interval Timer Function

The following settings apply to the general timing diagram.

- INTTAUJnIm is generated at the beginning of operation. (TAUJnCMORm.TAUJnMD0 = 1)
- Rising edge detection (TAUJnCMURm.TAUJnTIS[1:0] = 01_B)

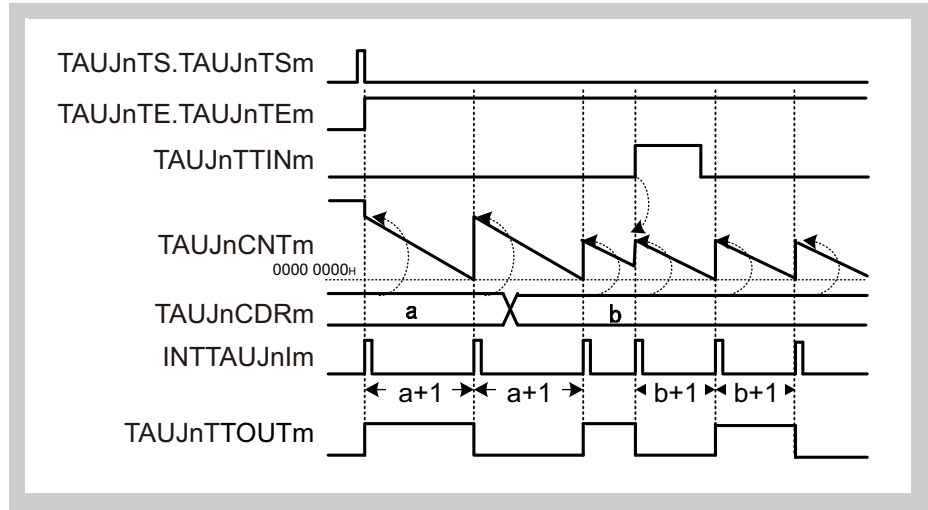

Figure 14-19 General Timing Diagram of TAUJnTTINm Input Interval Timer Function

(4) Register settings

(a) TAUJnCMORM

15	14	13	12	11	10	9	8	7	6	5	4	3	2	1	0
TAUJnCKS [1:0]	TAUJnCCS [1:0]	TAUJnMAS	TAUJnSTS[2:0]			TAUJnCOS [1:0]		-	TAUJnMD[4:1]				TAUJnMD0		

Table 14-15 TAUJnCMORM Settings for TAUJnTTINm Input Interval Timer Function

Bit Name	Setting
TAUJnCKS[1:0]	Selects the sampling clock 00: Prescaler output CK0 01: Prescaler output CK1 10: Prescaler output CK2 11: Prescaler output CK3
TAUJnCCS[1:0]	00: Sampling clock is used as the count clock
TAUJnMAS	0: Unused. Set to 0
TAUJnSTS[2:0]	001: Valid TAUJnTTINm input edge signal is used as the external start trigger
TAUJnCOS[1:0]	00: Unused. Set to 00
TAUJnMD[4:1]	0000: Interval Timer Mode
TAUJnMD0	0: INTTAUJnIm is not generated and TAUJnTTOUTm does not toggle at the beginning of operation 1: INTTAUJnIm is generated and TAUJnTTOUTm toggles at the beginning of operation

(b) TAUJnCMURm

7	6	5	4	3	2	1	0
-						TAUJnTIS[1:0]	

Table 14-16 TAUJnCMURm Settings for TAUJnTTINm Input Interval Timer Function

Bit Name	Setting
TAUJnTIS[1:0]	00: Falling edge detection 01: Rising edge detection 10: Rising and falling edge detection 11: Setting prohibited

(c) Channel output mode**Table 14-17 Control Bit Settings for Independent Channel Output Mode 1**

Bit Name	Setting
TAUJnTOE.TAUJnTOEm	1: Enables Independent Channel Output Mode
TAUJnTO.TAUJnTOm	0: Low level 1: High level
TAUJnTOM.TAUJnTOMm	0: Independent channel output
TAUJnTOC.TAUJnTOCm	0: Operating mode 1 (Toggle mode if TAUJnTOM.TAUJnTOMm = 0)
TAUJnTOL.TAUJnTOLm	0: Positive logic

Note The channel output mode can also be set to channel output mode controlled by software by setting TAUJnTOE.TAUJnTOEm = 0. TAUJnTTOUTm can then be controlled independently of the interrupts. For details, see Section 14.8, Channel Output Modes.

(d) Simultaneous rewrite

The simultaneous rewrite registers (TAUJnRDE and TAUJnRDM) cannot be used with the TAUJnTTINm Input Interval Timer Function. Therefore, these registers should be set to 0.

Table 14-18 Simultaneous Rewrite Settings for TAUJnTTINm Input Interval Timer Function

Bit Name	Setting
TAUJnRDE.TAUJnRDEm	0: Disables simultaneous rewrite
TAUJnRDM.TAUJnRDMm	0: When simultaneous rewrite is disabled (TAUJnRDE.TAUJnRDEm = 0), set these bits to 0

(5) Operating procedure for TAUJnTTINm Input Interval Timer Function

Table 14-19 Operating Procedure for TAUJnTTINm Input Interval Timer Function

	Operation	TAUJn Status
Restart ↓	Initial channel setting	Channel operation is stopped.
	Start operation	TAUJnTE.TAUJnTEm is set to 1 and the counter starts. TAUJnCDRm value is loaded in TAUJnCNTm. When TAUJnCMORm.TAUJnMD0 = 1, INTTAUJnIm is generated and TAUJnTTOUTm toggles.
	During operation	TAUJnCNTm counts down. When the counter reaches 0000 0000 _H : <ul style="list-style-type: none"> TAUJnCNTm reloads the TAUJnCDRm value and continues count operation INTTAUJnIm is generated and TAUJnTTOUTm toggles When a valid TAUJnTTINm input edge is detected during count operation, TAUJnCNTm reloads the TAUJnCDRm value and continues count operation. Afterwards, this procedure is repeated.
	Stop operation	TAUJnTE.TAUJnTEm is cleared to 0 and the counter stops. TAUJnCNTm and TAUJnTTOUTm stop and retain their current values.

(6) Specific timing diagrams

Although the timing diagrams in Section 14.12.1, Interval Timer Function, also apply, but it is possible to use valid TAUJnTTINm input edge, by excluding this function, to restart the counter.

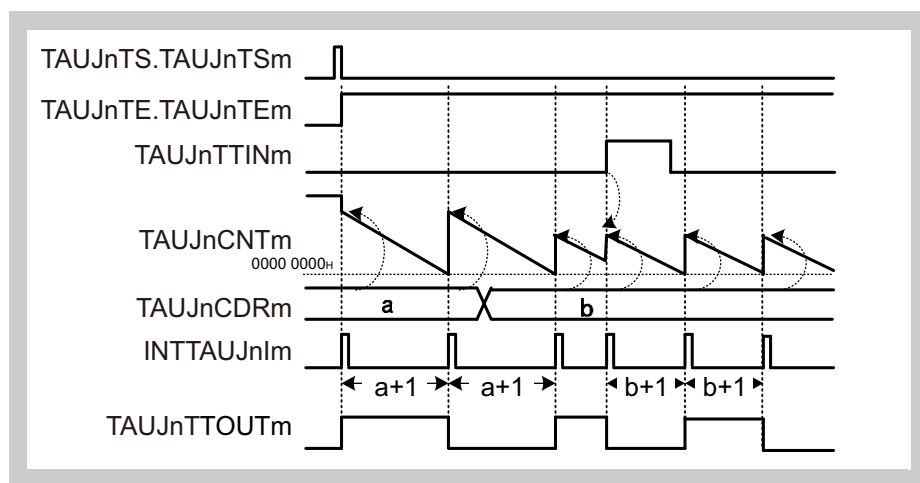

Figure 14-20 Counter Triggered by Rising TAUJnTTINm Input Edge (TAUJnCMURm.TAUJnTIS[1:0] = 01_B), TAUJnCMORm.TAUJnMD0 = 1

- If a valid TAUJnTTINm input edge is detected, an interrupt is generated which causes TAUJnTTOUTm to toggle. In this example, the valid edge is a rising edge (TAUJnCMURm.TAUJnTIS[1:0] = 01_B).

14.12.3 TAUJnTTINm Input Pulse Interval Measurement Function

(1) Overview

- Summary** This function captures the count value and uses this value and the overflow bit TAUJnCSRm.TAUJnOVF to measure the interval of the TAUJnTTINm input signals.
- Prerequisites**
- The operating mode should be set to capture mode. (See Table 14-21, TAUJnCMORm Settings for TAUJnTTINm Input Pulse Interval Measurement Function.)
 - TAUJnTTOUTm is not used with this function.
- Functional description** The counter is started by setting the channel trigger bit (TAUJnTS.TAUJnTSm) to 1. This in turn sets TAUJnTE.TAUJnTEm = 1, enabling count operation. The counter TAUJnCNTm starts counting up from 0000 0000_H. When a valid TAUJnTTINm edge is detected, the value of TAUJnCNTm is captured and transferred to TAUJnCDRm, and an interrupt INTTAUJnIm is generated. The counters reset to 0000 0000_H and subsequently continue operation.
- If the counter reaches FFFF FFFF_H before a valid TAUJnTTINm edge is detected, a counter overflow occurs. The counter is reset to 0000 0000_H and continues operation. The values transferred to TAUJnCDRm and TAUJnCSRm.TAUJnOVF respectively depend on the values of TAUJnCMORm.TAUJnCOS[1:0] bits.

Table 14-20 Effects of an Overflow

TAUJnCMORm. TAUJnCOS[1:0]	When Overflow Occurs		When Valid TAUJnTTINm Input Is Detected after Overflow	
	TAUJnCDRm	TAUJnCSRm. TAUJnOVF	TAUJnCDRm, TAUJnCNTm	TAUJnCSRm. TAUJnOVF
00	Unchanged	0	TAUJnCNTm is loaded into TAUJnCDRm	1
01		1		
10	Set to FFFF FFFF _H	0	TAUJnCNTm is set to 0 and TAUJnCDRm remains unchanged	Unchanged
11		1		

When TAUJnCMORm.TAUJnCOS[0] = 1, the overflow bit TAUJnCSRm.TAUJnOVF can be cleared only by setting the TAUJnCSCm.TAUJnCLOV bit to 1.

The combination of the values of TAUJnCDRm and TAUJnCSRm.TAUJnOVF can be used to deduce the interval of the TAUJnTTINm signal. However, if multiple overflows occur before a valid TAUJnTTINm input is detected, the overflow bit TAUJnCSRm.TAUJnOVF cannot indicate their occurrences.

The function can be stopped by setting TAUJnTT.TAUJnTTm = 1, which in turn sets TAUJnTE.TAUJnTEm = 0. TAUJnCNTm stops but retains its value. While the function is stopped, valid TAUJnTTINm input edge detection and TAUJnCNTm capture are not performed.

- Conditions** If the TAUJnCMORm.TAUJnMD0 bit is set to 0, the first interrupt after a start or restart is not generated. For details, see section 14.10, TAUJnTTOUTm Output and INTTAUJnIm Generation When Counter Starts or Restarts.

Note When TAUJnCMORm.TAUJnCOS[1] = 1, the value of TAUJnCNTm is not loaded into TAUJnCDRm when the first valid TAUJnTTINm input edge occurs after an overflow. However, an interrupt is generated.

(2) Equations

$$\text{TAUJnTTINm input pulse interval} = \text{Count clock cycle} \times [(\text{TAUJnCSRm.TAUJnOVF} \times (\text{FFFF FFFF}_H + 1)) + \text{TAUJnCDRm capture value} + 1]$$

(3) Block diagram and general timing diagram

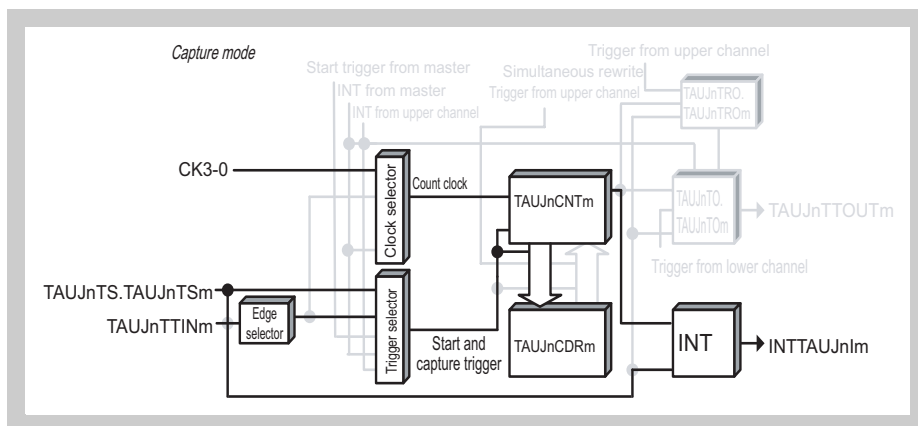

Figure 14-21 Block Diagram of TAUJnTTINm Input Pulse Interval Measurement Function

The following settings apply to the general timing diagram:

- INTTAUJnIm is not generated at the beginning of operation. (TAUJnCMORm.TAUJnMD0 = 0)
- Falling edge detection (TAUJnCMURm.TAUJnTIS[1:0] = 00_B)
- When a valid TAUJnTTINm input is detected after an overflow, TAUJnCDRm is changed and TAUJnCSRm.TAUJnOVF is set to 1 (TAUJnCMORm.TAUJnCOS[1:0] = 00_B).

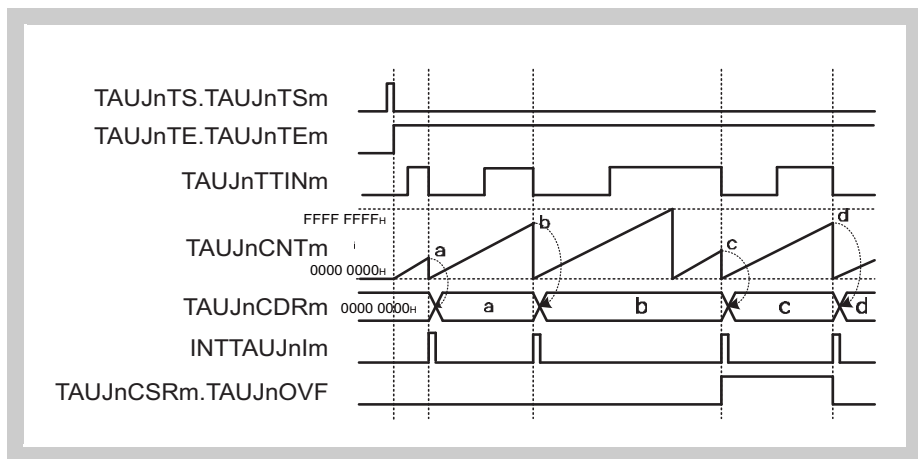

Figure 14-22 General Timing Diagram of TAUJnTTINm Input Pulse Interval Measurement Function

(4) Register settings

(a) TAUJnCMORM

15	14	13	12	11	10	9	8	7	6	5	4	3	2	1	0
TAUJnCKS [1:0]	TAUJnCCS [1:0]	TAUJnMAS	TAUJnSTS[2:0]			TAUJnCOS [1:0]		-	TAUJnMD[4:1]				TAUJnMD0		

Table 14-21 TAUJnCMORM Settings for TAUJnTTINm Input Pulse Interval Measurement Function

Bit Name	Setting
TAUJnCKS[1:0]	Selects the sampling clock 00: Prescaler output CK0 01: Prescaler output CK1 10: Prescaler output CK2 11: Prescaler output CK3
TAUJnCCS[1:0]	00: Sampling clock is used as a count clock
TAUJnMAS	0: Unused. Set to 0
TAUJnSTS[2:0]	001: Valid edge of TAUJnTTINm input signal is used as an external capture trigger
TAUJnCOS[1:0]	See Table 14-20, Effects of an Overflow
TAUJnMD[4:1]	0010: Capture mode
TAUJnMD0	0: INTTAUJnIm is not generated at the beginning of operation 1: INTTAUJnIm is generated at the beginning of operation

(b) TAUJnCMURm

7	6	5	4	3	2	1	0
-						TAUJnTIS[1:0]	

Table 14-22 TAUJnCMURm Settings for TAUJnTTINm Input Pulse Interval Measurement Function

Bit Name	Setting
TAUJnTIS[1:0]	00: Falling edge detection 01: Rising edge detection 10: Rising and falling edge detection 11: Setting prohibited

(c) Channel output mode

TAUJnTOE.TAUJnTOEm is set to 0 because the channel output mode is not used with this function. However, this mode can be used in independent channel output mode controlled by software.

(d) Simultaneous rewrite

The simultaneous rewrite registers (TAUJnRDE and TAUJnRDM) cannot be used with the TAUJnTTINm Input Pulse Interval Measurement Function. Therefore, these registers should be set to 0.

Table 14-23 Simultaneous Rewrite Settings for TAUJnTTINm Input Pulse Interval Measurement Function

Bit Name	Setting
TAUJnRDE.TAUJnRDEm	0: Disables simultaneous rewrite
TAUJnRDM.TAUJnRDMm	0: When simultaneous rewrite is disabled (TAUJnRDE.TAUJnRDEm = 0), set these bits to 0.

(5) Operating procedure for TAUJnTTINm Input Pulse Interval Measurement Function

Table 14-24 Operating Procedure for TAUJnTTINm Input Pulse Interval Measurement Function

	Operation	TAUJn Status
Initial channel setting	<p>Set the TAUJnCMORm and TAUJnCMURm registers as described in Table 14-21, TAUJnCMORm Settings for TAUJnTTINm Input Pulse Interval Measurement Function, and Table 14-22, TAUJnCMURm Settings for TAUJnTTINm Input Pulse Interval Measurement Function.</p> <p>The TAUJnCDRm register functions as a capture register.</p>	Channel operation is stopped.
Start operation	<p>Set TAUJnTS.TAUJnTSM to 1. TAUJnTS.TAUJnTSM is a trigger bit, which is automatically cleared to 0.</p>	<p>TAUJnTE.TAUJnTEM is set to 1 and the counter starts. TAUJnCNTm is cleared to 0000 0000_H. When TAUJnCMORm.TAUJnMD0 = 1, INTTAUJnIm is generated.</p>
During operation	<p>Detection of TAUJnTTINm edge.</p> <p>The values of the TAUJnCMURm.TAUJnTIS[1:0] bits can be changed at any time. TAUJnCDRm and TAUJnCSRm registers are readable at any time. TAUJnCSCm.TAUJnCLOV can be set to 1 (TAUJnCSRm.TAUJnOVF bit is cleared to 0.)</p>	<p>TAUJnCNTm starts to count up from 0000 0000_H. When a valid edge of TAUJnTTINm is detected:</p> <ul style="list-style-type: none"> • TAUJnCNTm transfers (captures) its value to TAUJnCDRm and returns to 0000 0000_H. • Then, INTTAUJnIm is generated. <p>Afterwards, this procedure is repeated.</p>
Stop operation	<p>Set TAUJnTT.TAUJnTTM to 1. TAUJnTT.TAUJnTTM is a trigger bit, which is automatically cleared to 0.</p>	<p>TAUJnTE.TAUJnTEM is cleared to 0 and the counter stops. TAUJnCNTm stops. TAUJnCNTm and TAUJnCSRm.TAUJnOVF retain their current values.</p>

Restart



(6) Specific timing diagrams: Overflow operation

(a) $\text{TAUJnCMORm.TAUJnCOS}[1:0] = 00_{\text{B}}$ 

Figure 14-23 $\text{TAUJnCMORm.TAUJnCOS}[1:0] = 00_{\text{B}}$, $\text{TAUJnCMORm.TAUJnMD0} = 0$,
 $\text{TAUJnCMURm.TAUJnTIS}[1:0] = 00_{\text{B}}$

- When an overflow occurs, the value of TAUJnCDRm remains unchanged and TAUJnCSRm.TAUJnOVF remains 0.
- Upon detection of the next valid TAUJnTTINm input edge, the value of TAUJnCNTm is loaded into TAUJnCDRm and TAUJnCSRm.TAUJnOVF is set to 1.
- Upon detection of the next valid TAUJnTTINm input edge with no overflow occurring, TAUJnCSRm.TAUJnOVF is cleared to 0.

(b) $\text{TAUJnCMORm.TAUJnCOS}[1:0] = 01_{\text{B}}$ 

Figure 14-24 $\text{TAUJnCMORm.TAUJnCOS}[1:0] = 01_{\text{B}}$, $\text{TAUJnCMORm.TAUJnMD0} = 0$,
 $\text{TAUJnCMURm.TAUJnTIS}[1:0] = 00_{\text{B}}$

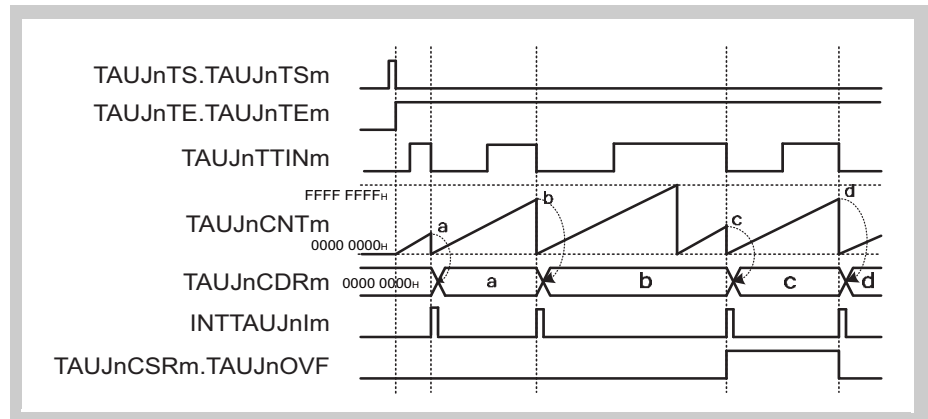
- When an overflow occurs, the value of TAUJnCDRm remains unchanged and TAUJnCSRm.TAUJnOVF is set to 1.
- Upon detection of the next valid TAUJnTTINm input edge, the value of TAUJnCNTm is loaded into TAUJnCDRm.
- TAUJnCSRm.TAUJnOVF is cleared by setting the TAUJnCSCm.TAUJnCLOV bit to 1.

(c) TAUJnCMORM.TAUJnCOS[1:0] = 10_B

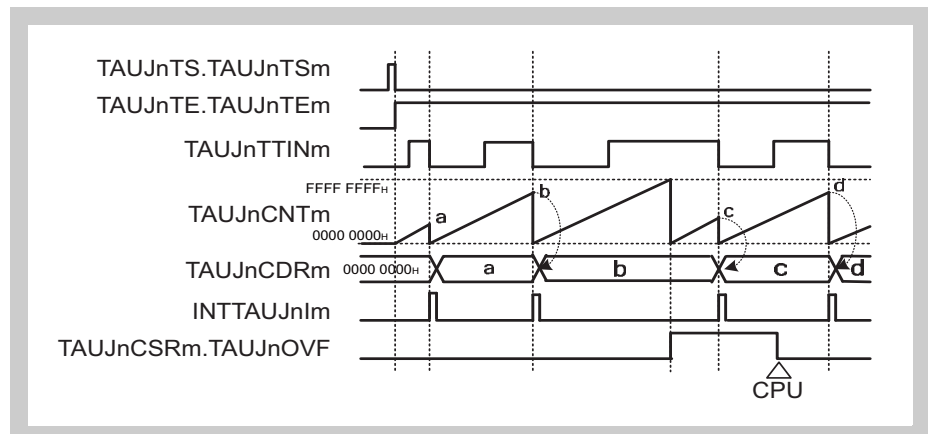
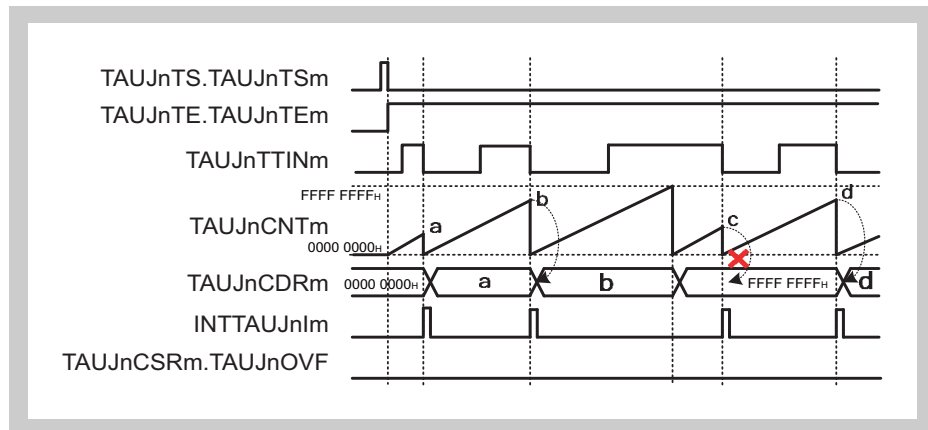

Figure 14-25 TAUJnCMORM.TAUJnCOS[1:0] = 10_B, TAUJnCMORM.TAUJnMD0 = 0, TAUJnCMURm.TAUJnTIS[1:0] = 00_B

- When an overflow occurs, TAUJnCDRm is set to FFFF FFFF_H and TAUJnCSRm.TAUJnOVF remains 0.
- Upon detection of the next valid TAUJnTTINm input edge, TAUJnCNTm is reset to 0, but TAUJnCDRm and TAUJnCSRm.TAUJnOVF remain unchanged.
- Thus, the next valid TAUJnTTINm input edge after an overflow is ignored.

(d) TAUJnCMORM.TAUJnCOS[1:0] = 11_B

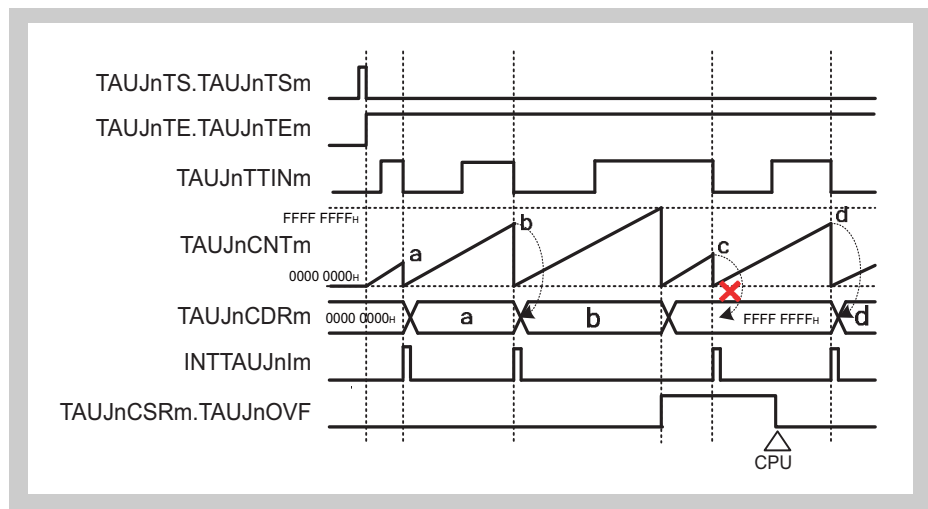

Figure 14-26 TAUJnCMORM.TAUJnCOS[1:0] = 11_B, TAUJnCMORM.TAUJnMD0 = 0, TAUJnCMURm.TAUJnTIS[1:0] = 00_B

- When an overflow occurs, TAUJnCDRm is set to FFFF FFFF_H, and TAUJnCSRm.TAUJnOVF is set to 1.
- Upon detection of the next valid TAUJnTTINm input edge, TAUJnCNTm is reset to 0, but TAUJnCDRm and TAUJnCSRm.TAUJnOVF remain unchanged.
- Thus, the next valid TAUJnTTINm input edge after the overflow is ignored.
- TAUJnCSRm.TAUJnOVF is cleared by setting the TAUJnCSCm.TAUJnCLOV bit to 1.

14.12.4 TAUJnTTINm Input Signal Width Measurement Function

(1) Overview

- Summary** This function measures the width of a TAUJnTTINm input signal.
- Prerequisites**
- The operating mode should be set to Capture & One-Count Mode. (See Table 14-26, TAUJnCMORm Settings for TAUJnTTINm Input Signal Width Measurement Function.)
 - TAUJnTTOUTm is not used with this function.
 - TAUJnCMORm.TAUJnMD0 should be set to 0.

Functional description The counter is started by setting the channel trigger bit (TAUJnTS.TAUJnTSm) to 1. This in turn sets TAUJnTE.TAUJnTEm = 1, enabling count operation. When a valid TAUJnTTINm start edge is detected, the counter TAUJnCnTm starts counting up from 0000 0000_H. When a valid TAUJnTTINm stop edge is detected, the value of TAUJnCnTm is captured and transferred to TAUJnCDRm, and an interrupt INTTAUJnIm is generated. The counter retains its value and awaits the next valid TAUJnTTINm input start edge.

If the counter reaches FFFF FFFF_H before a valid TAUJnTTINm stop edge is detected, it overflows. The counter is reset to 0000 0000_H and subsequently continues operation. The values transferred to TAUJnCDRm and TAUJnCSRm.TAUJnOVF respectively depend on the values of TAUJnCMORm.TAUJnCOS[1:0] bits.

Table 14-25 Effects of Overflow

TAUJnCMORm. TAUJnCOS[1:0]	When Overflow Occurs		When Valid TAUJnTTINm Input Stop Edge Is Detected	
	TAUJnCDRm	TAUJnCSRm. TAUJnOVF	TAUJnCDRm, TAUJnCnTm	TAUJnCSRm. TAUJnOVF
00	Unchanged	0	TAUJnCnTm is loaded into TAUJnCDRm	1
01		1		
10	Set to FFFF FFFF _H	0	TAUJnCnTm stops counting. TAUJnCDRm remains unchanged	Unchanged
11		1		

When TAUJnCMORm.TAUJnCOS[0] = 1, overflow bit TAUJnCSRm.TAUJnOVF can be cleared only by setting TAUJnCSCm.TAUJnCLOV to 1.

The combination of the values of TAUJnCDRm and TAUJnCSRm.TAUJnOVF can be used to deduce the width of the TAUJnTTINm signal. However, if multiple overflows occur before a valid TAUJnTTINm input is detected, the overflow bit TAUJnCSRm.TAUJnOVF cannot indicate their occurrences.

Caution The TAUJnTTINm input signal width measurement function cannot make a forced restart.

Note If TAUJnCMORm.TAUJnCOS[1] = 1, the value of TAUJnCnTm is not loaded into TAUJnCDRm when the first valid TAUJnTTINm input edge occurs after an overflow. However, an interrupt is generated.

(2) Equations

$$\text{TAUJnTTINm input signal width} = \text{Count clock cycle} \times [(\text{TAUJnCSRm.TAUJnOVF} \times (\text{FFFF FFFF}_H + 1)) + \text{TAUJnCDRm capture value} + 1]$$

(3) Block diagram and general timing diagram

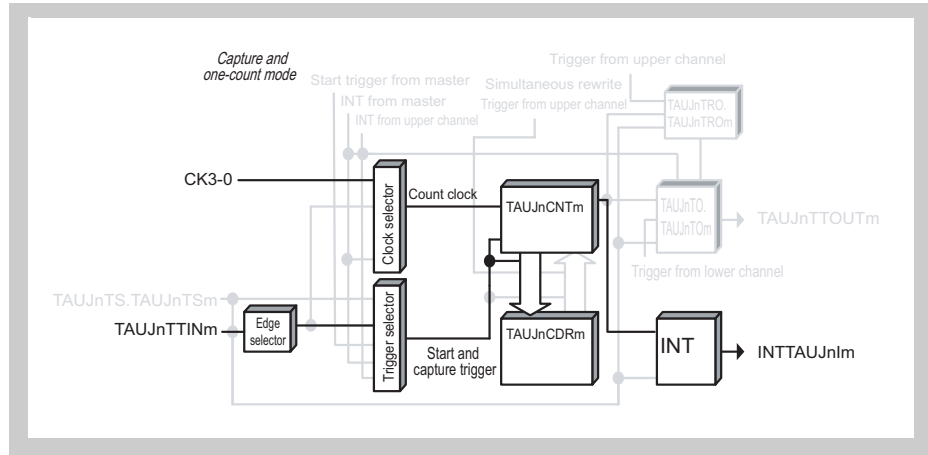

Figure 14-27 Block Diagram of TAUJnTTINm Input Signal Width Measurement Function

The following settings apply to the general timing diagram.

- Rising and falling edge detection = high width measurement (TAUJnCMURm.TAUJnTIS[1:0] = 11_B)
- When a valid TAUJnTTINm input is detected after an overflow, TAUJnCDRm is changed and TAUJnCSRm.TAUJnOVF is set to 1 (TAUJnCMORM.TAUJnCOS[1:0] = 00_B)

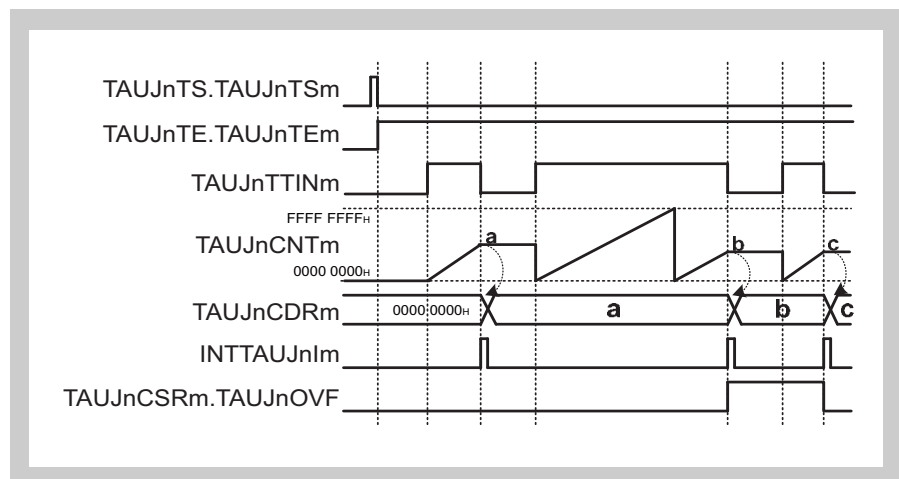

Figure 14-28 General Timing Diagram of TAUJnTTINm Input Signal Width Measurement Function

(4) Register settings

(a) TAUJnCMORM

15	14	13	12	11	10	9	8	7	6	5	4	3	2	1	0
TAUJnCKS [1:0]	TAUJnCCS [1:0]	TAUJnMAS	TAUJnSTS[2:0]			TAUJnCOS [1:0]		-	TAUJnMD[4:1]				TAUJnMD0		

Table 14-26 TAUJnCMORM Settings for TAUJnTTINm Input Signal Width Measurement Function

Bit Name	Setting
TAUJnCKS[1:0]	Selects the sampling clock 00: Prescaler output CK0 01: Prescaler output CK1 10: Prescaler output CK2 11: Prescaler output CK3
TAUJnCCS[1:0]	00: Sampling clock is used as a count clock.
TAUJnMAS	0: Unused. Set to 0.
TAUJnSTS[2:0]	010: Valid edge of TAUJnTTINm input signal is used as an external start trigger and the reverse edge as a stop trigger
TAUJnCOS[1:0]	See Table 14-25, Effects of Overflow
TAUJnMD[4:1]	0110: Capture & one-count mode
TAUJnMD0	0: Disables the start trigger during operation.

(b) TAUJnCMURm

7	6	5	4	3	2	1	0
-						TAUJnTIS[1:0]	

Table 14-27 TAUJnCMURm Settings for TAUJnTTINm Input Signal Width Measurement Function

Bit Name	Setting
TAUJnTIS[1:0]	10: Rising and falling edge detection (low width measurement) 11: Rising and falling edge detection (high width measurement)

(c) Channel output mode

TAUJnTOE.TAUJnTOEm is set to 0 because the channel output mode is not used with this function. However, this mode can be used in independent channel output mode controlled by software.

(d) Simultaneous rewrite

The simultaneous rewrite registers (TAUJnRDE and TAUJnRDM) cannot be used with the TAUJnTTINm Input Signal Width Measurement Function. Therefore, these registers should be set to 0.

Table 14-28 Simultaneous Rewrite Settings for TAUJnTTINm Input Signal Width Measurement Function

Bit Name	Setting
TAUJnRDE.TAUJnRDEm	0: Disables simultaneous rewrite
TAUJnRDM.TAUJnRDMm	0: When disabling simultaneous rewrite (TAUJnRDE.TAUJnRDEm = 0), set these bits to 0

(5) Operating procedure for TAUJnTTINm Input Signal Width Measurement Function

Table 14-29 Operating Procedure for TAUJnTTINm Input Signal Width Measurement Function

	Operation	TAUJn Status
Initial channel setting	Set the TAUJnCMORm and TAUJnCMURm registers as described in Table 14-26, TAUJnCMORm Settings for TAUJnTTINm Input Signal Width Measurement Function, and Table 14-27, TAUJnCMURm Settings for TAUJnTTINm Input Signal Width Measurement Function. The TAUJnCDRm register functions as a capture register.	Channel operation is stopped.
Start operation	Set TAUJnTS.TAUJnTSM to 1. TAUJnTS.TAUJnTSM is a trigger bit, which is automatically cleared to 0.	TAUJnTE.TAUJnTEM is set to 1 and TAUJnCNTm awaits TAUJnTTINm start edge detection. When TAUJnTTINm start edge is detected, TAUJnCNTm starts to count up.
During operation	Detection of TAUJnTTINm edge. TAUJnCDRm, TAUJnCNTm, and TAUJnCSRm registers are readable at any time. TAUJnCSC.CLOV bit can be set to 1.	TAUJnCNTm starts to count up from 0000 0000 _H . When a valid TAUJnTTINm edge is detected: <ul style="list-style-type: none"> TAUJnCNTm transfers (captures) its value to TAUJnCDRm and retains its value. INTTAUJnIm is then generated. Afterwards, this procedure is repeated.
Stop operation	Set TAUJnTT.TAUJnTTM to 1. TAUJnTT.TAUJnTTM is a trigger bit, which is automatically cleared to 0.	TAUJnTE.TAUJnTEM is cleared to 0 and the counter stops. TAUJnCNTm stops. TAUJnCNTm and TAUJnCSRm.TAUJnOVF retain their current values.

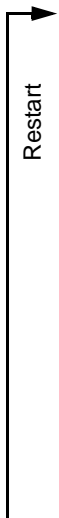

(6) Specific timing diagrams: Overflow operation

(a) $\text{TAUJnCMORm.TAUJnCOS}[1:0] = 00_{\text{B}}$ 

Figure 14-29 $\text{TAUJnCMORm.TAUJnCOS}[1:0] = 00_{\text{B}}$, $\text{TAUJnCMORm.TAUJnMD0} = 0$,
 $\text{TAUJnCMURm.TAUJnTIS}[1:0] = 11_{\text{B}}$

- When an overflow occurs, the value of TAUJnCDRm remains unchanged and $\text{TAUJnCSRm.TAUJnOVF}$ remains 0.
- Upon detection of the next valid TAUJnTTINm input edge, the value of TAUJnCNTm is loaded into TAUJnCDRm and $\text{TAUJnCSRm.TAUJnOVF}$ is set to 1.
- Upon detection of the next valid TAUJnTTINm input edge with no overflow occurring, $\text{TAUJnCSRm.TAUJnOVF}$ is cleared to 0.

(b) $\text{TAUJnCMORm.TAUJnCOS}[1:0] = 01_{\text{B}}$ 

Figure 14-30 $\text{TAUJnCMORm.TAUJnCOS}[1:0] = 01_{\text{B}}$, $\text{TAUJnCMORm.TAUJnMD0} = 0$,
 $\text{TAUJnCMURm.TAUJnTIS}[1:0] = 11_{\text{B}}$

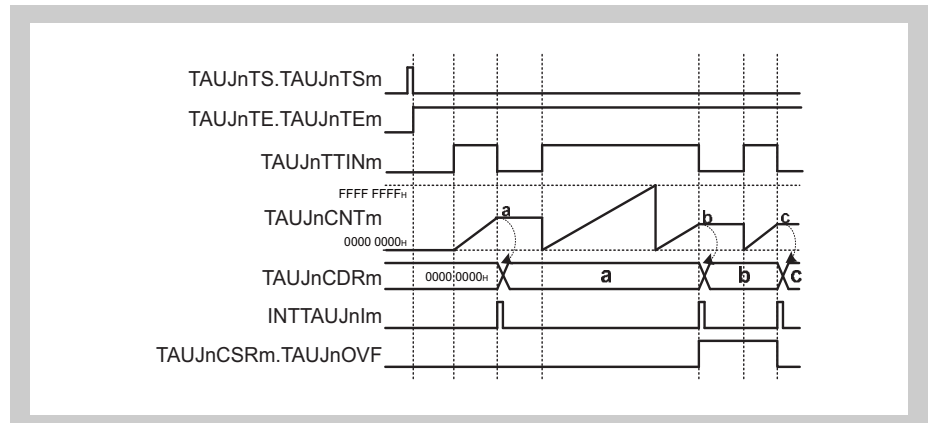
- When an overflow occurs, the value of TAUJnCDRm remains unchanged and $\text{TAUJnCSRm.TAUJnOVF}$ is set to 1.
- Upon detection of the next valid TAUJnTTINm input edge, the value of TAUJnCNTm is loaded into TAUJnCDRm .
- $\text{TAUJnCSRm.TAUJnOVF}$ is cleared by setting the $\text{TAUJnCSCm.TAUJnCLOV}$ bit to 1.

(c) TAUJnCMORM.TAUJnCOS[1:0] = 10_B

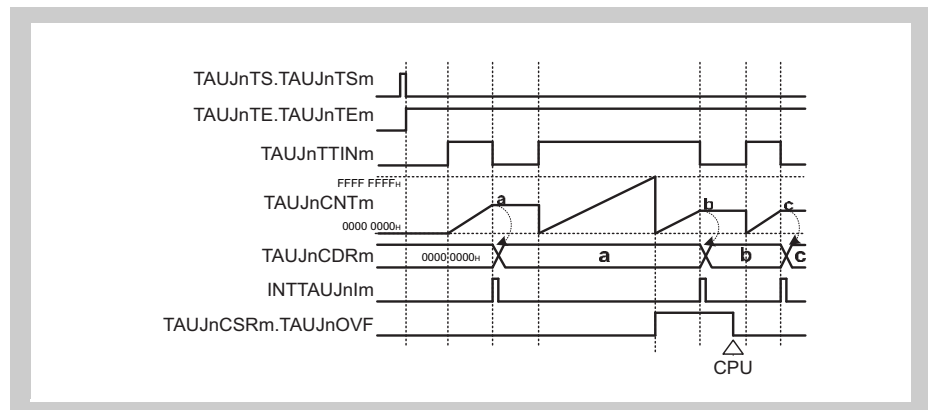
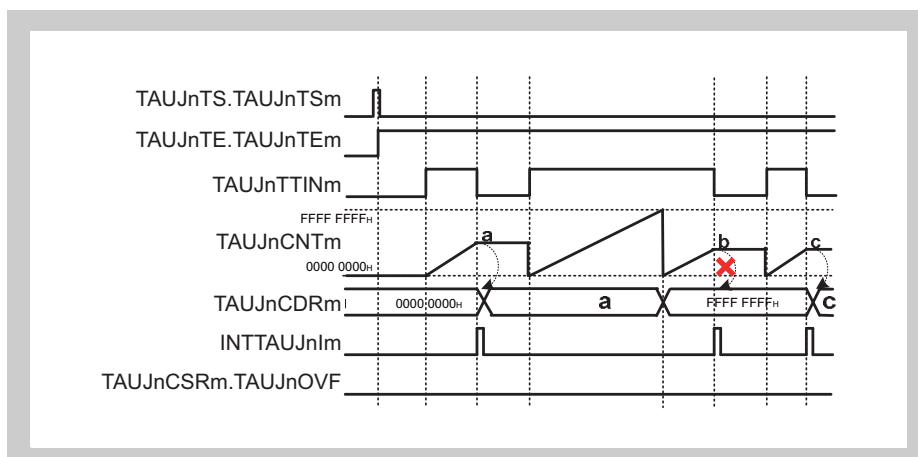

Figure 14-31 TAUJnCMORM.TAUJnCOS[1:0] = 10_B, TAUJnCMORM.TAUJnMD0 = 0, TAUJnCMURm.TAUJnTIS[1:0] = 11_B

- When an overflow occurs, TAUJnCDRm is set to FFFF FFFF_H and TAUJnCSRm.TAUJnOVF remains 0.
- Upon detection of the next valid TAUJnTTINm input edge, TAUJnCNTm is reset to 0, but TAUJnCDRm and TAUJnCSRm.TAUJnOVF remain unchanged.
- Thus, the next valid TAUJnTTINm input edge after the overflow is ignored.

(d) TAUJnCMORM.TAUJnCOS[1:0] = 11_B

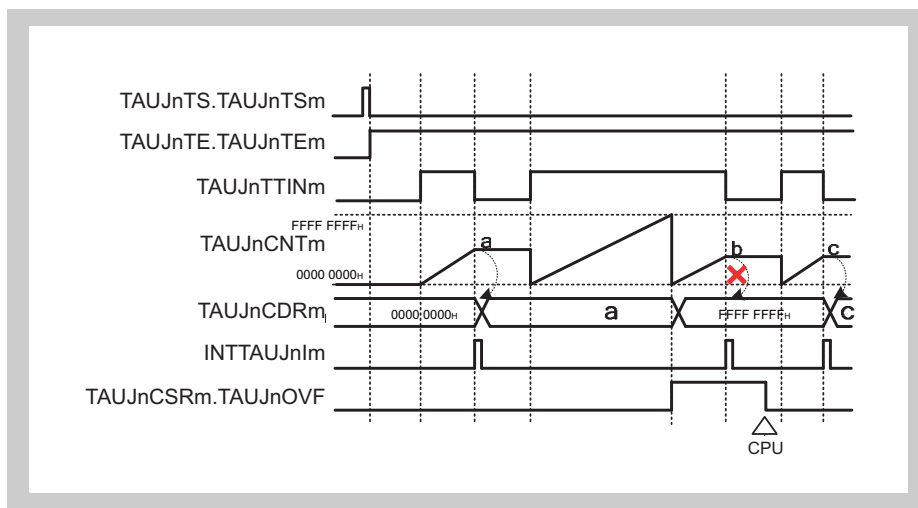

Figure 14-32 TAUJnCMORM.TAUJnCOS[1:0] = 11_B, TAUJnCMORM.TAUJnMD0 = 0, TAUJnCMURm.TAUJnTIS[1:0] = 11_B

- When an overflow occurs, TAUJnCDRm is set to FFFF FFFF_H, and TAUJnCSRm.TAUJnOVF is set to 1.
- Upon detection of the next valid TAUJnTTINm input edge, TAUJnCNTm is reset to 0, but TAUJnCDRm and TAUJnCSRm.TAUJnOVF remain unchanged.
- Thus, the next valid TAUJnTTINm input edge after the overflow is ignored.
- TAUJnCSRm.TAUJnOVF is cleared by setting the TAUJnCSCm.TAUJnCLOV bit to 1.

14.12.5 TAUJnTTINm Input Period Count Detection Function

(1) Overview

- Summary** This function measures the cumulative width of a TAUJnTTINm input signal.
- Prerequisites**
- The operating mode should be set to capture & gate count mode. (See Table 14-30, TAUJnCMORm Settings for TAUJnTTINm Input Period Count Detection Function.)
 - TAUJnTTOUTm is not used with this function.
- Functional description**
- The counter is enabled by setting the channel trigger bit (TAUJnTS.TAUJnTSm) to 1. This in turn sets TAUJnTE.TAUJnTEm = 1, enabling count operation. The counter awaits a valid TAUJnTTINm input edge.
- When a valid TAUJnTTINm input start edge is detected, the counter starts to count from 0000 0000_H.
- When a valid TAUJnTTINm input stop edge is detected, the current TAUJnCNTm value is loaded into TAUJnCDRm and an interrupt (INTTAUJnIm) is generated. The counter stops and retains its value until the next valid TAUJnTTINm input start edge is detected.
- When the next TAUJnTTINm input start edge is detected, the counter restarts counting from the stop value.
- When the counter reaches FFFF FFFF_H, the counter restarts counting from 0000 0000_H.
- Note** An input signal TAUJnTTINm is sampled at the frequency of the prescaler output set by the TAUJnCMORm.TAUJnCKs[1:0] bits.
- Conditions** Valid start and stop edges are specified by the TAUJnCMURm.TAUJnTIS[1:0] bits.
- If TAUJnCMURm.TAUJnTIS[1:0] = 10_B, the TAUJnTTINm input low period is measured. The start trigger is a falling edge and the stop trigger is a rising edge.
 - If TAUJnCMURm.TAUJnTIS[1:0] = 11_B, the TAUJnTTINm input high period is measured. The start trigger is a rising edge and the stop trigger is a falling edge.

(2) Equations

Cumulative TAUJnTTINm input width = Count clock cycle × (TAUJnCDRm capture value + 1)

(3) Block diagram and general timing diagram

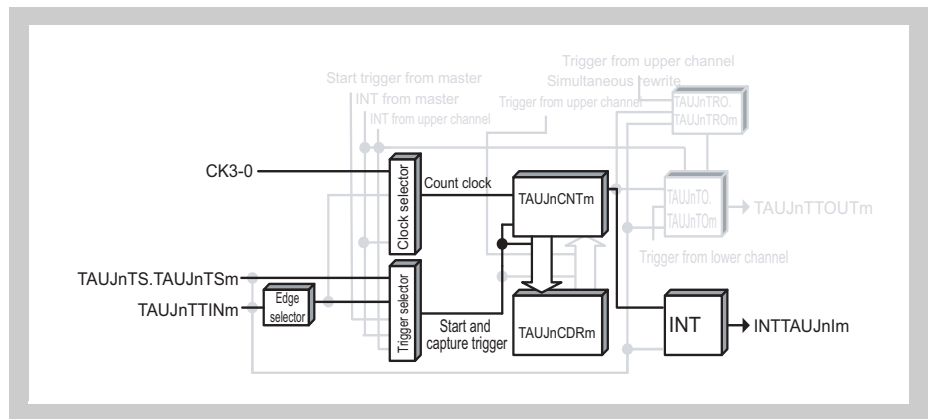

Figure 14-33 Block Diagram of TAUJnTTINm Input Period Count Detection Function

The following settings apply to the general timing diagram.

- Rising and falling edge detection = high width measurement (TAUJnCMURm.TAUJnTIS[1:0] = 11_B)

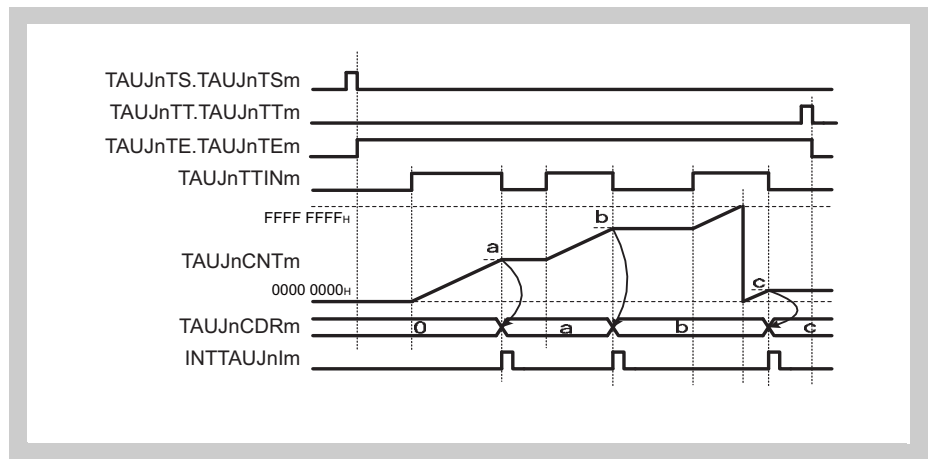

Figure 14-34 General Timing Diagram of TAUJnTTINm Input Period Count Detection Function

(4) Register settings**(a) TAUJnCMORM**

15	14	13	12	11	10	9	8	7	6	5	4	3	2	1	0
TAUJnCKS [1:0]		TAUJnCCS [1:0]		TAUJnMAS	TAUJnSTS[2:0]			TAUJnCOS [1:0]		-	TAUJnMD[4:1]				TAUJnMD0

Table 14-30 TAUJnCMORM Settings for TAUJnTTINm Input Period Count Detection Function

Bit Name	Setting
TAUJnCKS[1:0]	Selects a sampling clock 00: Prescaler output CK0 01: Prescaler output CK1 10: Prescaler output CK2 11: Prescaler output CK3
TAUJnCCS[1:0]	00: Sampling clock is used as a count clock
TAUJnMAS	0: Unused. Set to 0
TAUJnSTS[2:0]	010: Valid edge of the TAUJnTTINm input signal is used as an external start trigger and the reverse edge as a stop trigger
TAUJnCOS[1:0]	01: Set this value.
TAUJnMD[4:1]	1101: Capture & gate count mode
TAUJnMD0	0: Disables the start trigger during operation

(b) TAUJnCMURm

7	6	5	4	3	2	1	0
-							TAUJnTIS[1:0]

Table 14-31 TAUJnCMURm Settings for TAUJnTTINm Input Period Count Detection Function

Bit Name	Setting
TAUJnTIS[1:0]	10: Rising and falling edge detection (Low width measurement) 11: Rising and falling edge detection (High width measurement)

(c) Channel output mode

TAUJnTOE.TAUJnTOEm is set to 0 because the channel output mode is not used with this function. However, this mode can be used in independent channel output mode controlled by software.

(d) Simultaneous rewrite

The simultaneous rewrite registers (TAUJnRDE and TAUJnRDM) cannot be used with the TAUJnTTINm Input Period Count Detection Function. Therefore, these registers should be set to 0.

Table 14-32 Simultaneous Rewrite Settings for TAUJnTTINm Input Period Count Detection Function

Bit Name	Setting
TAUJnRDE.TAUJnRDEm	0: Disables simultaneous rewrite
TAUJnRDM.TAUJnRDMm	0: When disabling simultaneous rewrite (TAUJnRDE.TAUJnRDEm = 0), set these bits to 0

(5) Operating procedure for TAUJnTTINm Input Period Count Detection Function**Table 14-33 Operating Procedure for TAUJnTTINm Input Period Count Detection Function**

	Operation	TAUJn Status
Restart	Initial channel setting Set the TAUJnCMORm and TAUJnCMURm registers as described in Table 14-30, TAUJnCMORm Settings for TAUJnTTINm Input Period Count Detection Function, and Table 14-31, TAUJnCMURm Settings for TAUJnTTINm Input Period Count Detection Function. The TAUJnCDRm register functions as a capture register.	Channel operation is stopped.
	Start operation Set TAUJnTS.TAUJnTSM to 1. TAUJnTS.TAUJnTSM is a trigger bit, which is automatically cleared to 0. Detection of TAUJnTTINm start edge.	TAUJnTE.TAUJnTEm is set to 1 and TAUJnCNTm awaits TAUJnTTINm start edge detection. When TAUJnTTINm start edge is detected, TAUJnCNTm is cleared to 0000 0000 _H and starts to count up.
	During operation Detection of TAUJnTTINm edge. TAUJnCDRm, TAUJnCNTm, and TAUJnCSRm registers are readable at any time.	When a TAUJnTTINm start edge (rising edge for high width measurement, falling edge for low width measurement) is detected, TAUJnCNTm starts counting up from the stop value. When TAUJnCNTm detects a stop edge (falling edge for high width measurement, rising edge for low width measurement), it transfers its value to TAUJnCDRm and INTTAUJnIm is generated. Counting stops at the "value transferred to TAUJnCDRm + 1" value and TAUJnCNTm waits for detection of the TAUJnTTINm start edge. When TAUJnCNTm reaches FFFF FFFF _H , the counter restarts to count from 0000 0000 _H . Afterwards, this procedure is repeated.
	Stop operation Set TAUJnTT.TAUJnTTm to 1. TAUJnTT.TAUJnTTm is a trigger bit, which is automatically cleared to 0.	TAUJnTE.TAUJnTEm is cleared to 0 and the counter stops. TAUJnCNTm stops. TAUJnCNTm remains its current value.

(6) Specific timing diagrams
 (a) Operation stop and restart

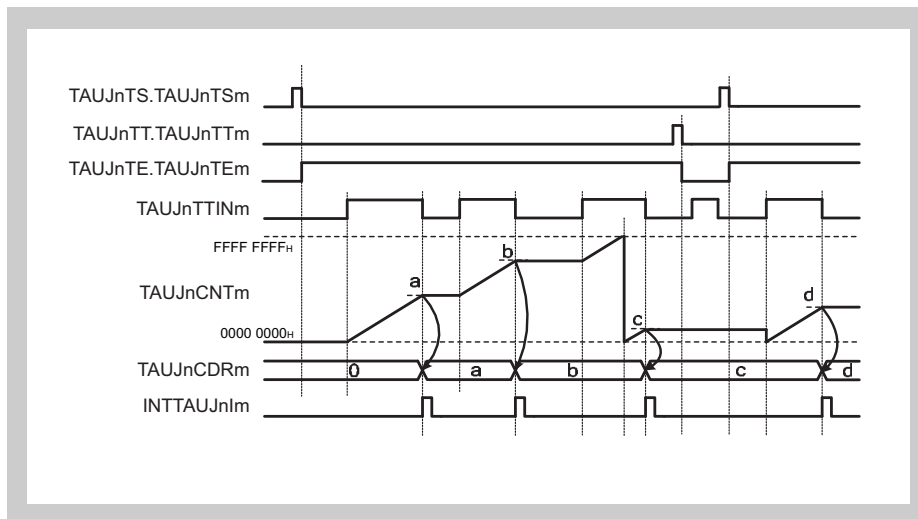

Figure 14-35 Operation Stop and Restart (TAUJnCMURm.TAUJnTIS[1:0] = 11_B)

- The counter can be stopped by setting TAUJnTT.TAUJnTTm to 1. This sets TAUJnTE.TAUJnTEm to 0.
- TAUJnCNTm stops and retains the current value.
- If the counter is stopped, valid TAUJnTTINm input edges are ignored.
- The counter can be restarted by setting TAUJnTS.TAUJnTSM to 1. TAUJnCNTm restarts counting from 0000 0000_H.

14.12.6 TAUJnTTINm Input Position Detection Function

(1) Overview

- Summary** This function measures a time period from count start timing until a TAUJnTTINm input signal.
- Prerequisites**
- The operating mode should be set to count capture mode. (See Table 14-34, TAUJnCMORm Settings for TAUJnTTINm Input Position Detection Function.)
 - TAUJnTTOUTm is not used with this function.
- Functional description** The counter is enabled by setting the channel trigger bit (TAUJnTS.TAUJnTSm) to 1. This in turn sets TAUJnTE.TAUJnTEm = 1, enabling count operation. The counter starts to count from 0000 0000_H. When a valid TAUJnTTINm input edge is detected, the current TAUJnCNTm value is loaded into TAUJnCDRm and an interrupt (INTTAUJnIm) is generated. The count operation continues.
- When the counter reaches FFFF FFFF_H, the counter restarts from 0000 0000_H.
- Conditions** If the TAUJnCMORm.TAUJnMD0 bit is set to 0, the first interrupt after a start or restart is not generated. For details, see Section 14.10, TAUJnTTOUTm Output and INTTAUJnIm Generation When Counter Starts or Restarts.

(2) Equations

Functional duration at a TAUJnTTINm input pulse =
 Count clock cycle × (TAUJnCDRm capture value + 1)

(3) Block diagram and general timing diagram

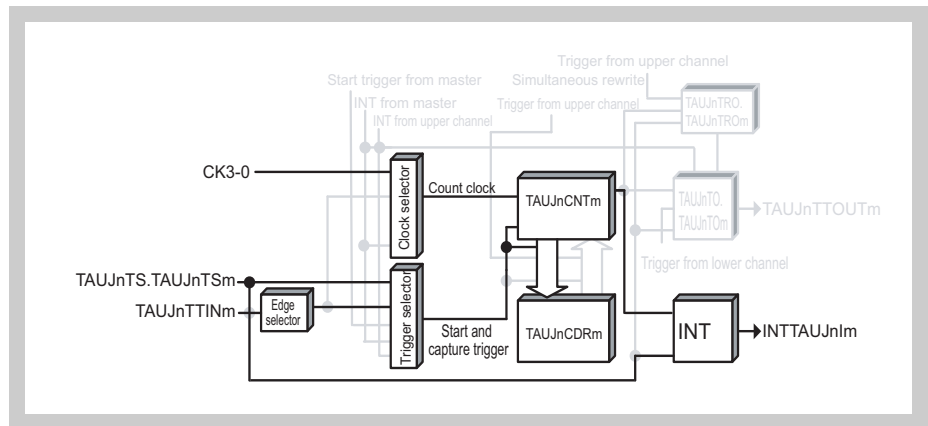

Figure 14-36 Block Diagram of TAUJnTTINm Input Position Detection Function

The following settings apply to the general timing diagram.

- INTTAUJnIm is not generated at the beginning of operation. (TAUJnCMORm.TAUJnMD0 = 0)
- Falling edge detection (TAUJnCMURm.TAUJnTIS[1:0] = 00_B)

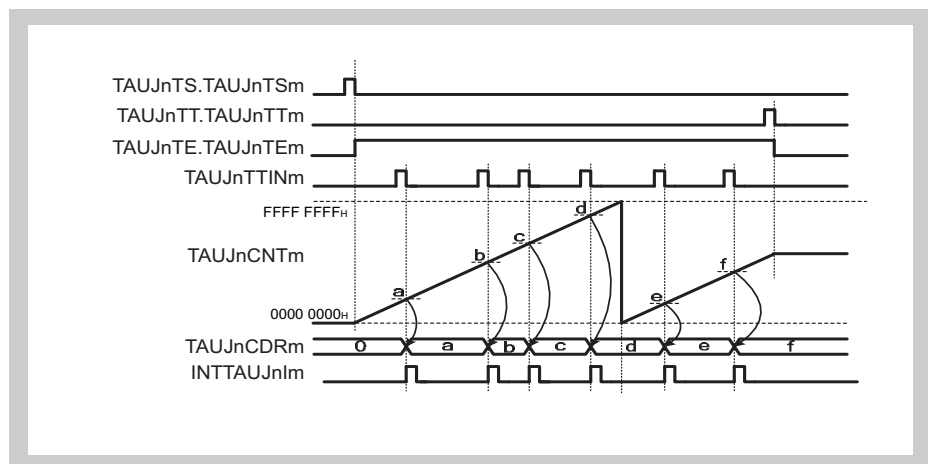

Figure 14-37 General Timing Diagram of TAUJnTTINm Input Position Detection Function

(4) Register settings**(a) TAUJnCMORM**

15	14	13	12	11	10	9	8	7	6	5	4	3	2	1	0
TAUJnCKS [1:0]		TAUJnCCS [1:0]		TAUJnMAS	TAUJnSTS[2:0]			TAUJnCOS [1:0]		-	TAUJnMD[4:1]				TAUJnMD0

Table 14-34 TAUJnCMORM Settings for TAUJnTTINm Input Position Detection Function

Bit Name	Setting
TAUJnCKS[1:0]	Selects a sampling clock 00: Prescaler output CK0 01: Prescaler output CK1 10: Prescaler output CK2 11: Prescaler output CK3
TAUJnCCS[1:0]	00: Sampling clock is used as a count clock
TAUJnMAS	0: Unused. Set to 0
TAUJnSTS[2:0]	001: Valid edge of the TAUJnTTINm input signal is used as an external capture trigger
TAUJnCOS[1:0]	01: Set this value.
TAUJnMD[4:1]	1011: Count capture mode
TAUJnMD0	0: INTTAUJnIm is not generated at the beginning of operation 1: INTTAUJnIm is generated at the beginning of operation

(b) TAUJnCMURm

7	6	5	4	3	2	1	0
-							TAUJnTIS[1:0]

Table 14-35 TAUJnCMURm Settings for TAUJnTTINm Input Position Detection Function

Bit Name	Setting
TAUJnTIS[1:0]	00: Falling edge detection 01: Rising edge detection 10: Rising and falling edge detection

(c) Channel output mode

This function does not use any channel output mode. However, channel output mode is available in independent channel output mode controlled by software. For details, see Section 14.8, Channel Output Modes.

(d) Simultaneous rewrite

The simultaneous rewrite registers (TAUJnRDE and TAUJnRDM) cannot be used with the TAUJnTTINm Input Position Detection Function. Therefore, these registers should be set to 0.

Table 14-36 Simultaneous Rewrite Settings for TAUJnTTINm Input Position Detection Function

Bit Name	Setting
TAUJnRDE.TAUJnRDEm	0: Disables simultaneous rewrite
TAUJnRDM.TAUJnRDMm	0: When disabling simultaneous rewrite (TAUJnRDE.TAUJnRDEm = 0), set these bits to 0

(5) Operating procedure for TAUJnTTINm Input Position Detection Function**Table 14-37 Operating Procedure for TAUJnTTINm Input Position Detection Function**

	Operation	TAUJn Status
Initial channel setting	Set the TAUJnCMORm and TAUJnCMURm registers as described in Table 14-34, TAUJnCMORm Settings for TAUJnTTINm Input Position Detection Function, and Table 14-35, TAUJnCMURm Settings for TAUJnTTINm Input Position Detection Function. TAUJnCDRm register operates as a capture register.	Channel operation is stopped.
Start operation	Set TAUJnTS.TAUJnTSM to 1. TAUJnTS.TAUJnTSM is a trigger bit, which is automatically cleared to 0.	TAUJnTE.TAUJnTEM is set to 1 and the counter is started. When TAUJnCMORm.TAUJnMD0 is set to 1, INTTAUJnIm is generated.
During operation	The TAUJnCMURm.TAUJnTIS[1:0] bits are changeable at any time. The TAUJnCDRm and TAUJnCSRm registers are readable at any time.	TAUJnCNTm starts to count up from 0000 0000 _H . When a valid TAUJnTTINm edge is detected: <ul style="list-style-type: none"> • TAUJnCNTm transfers (captures) its value to TAUJnCDRm. • INTTAUJnIm is generated. • The counter value is not cleared to 0000 0000_H and TAUJnCNTm continues to count. Afterwards, this procedure is repeated.
Stop operation	Set TAUJnTT.TAUJnTTM to 1. TAUJnTT.TAUJnTTM is a trigger bit, which is automatically cleared to 0.	TAUJnTE.TAUJnTEM is cleared to 0 and the counter stops. TAUJnCNTm stops. TAUJnCNTm remains its current value.

Restart

(6) Specific timing diagrams**(a) Operation stop and restart**

Figure 14-38 Operation Stop and Restart (TAUJnCMORM.TAUJnMD0 = 0, TAUJnCMURm.TAUJnTIS[1:0] = 00_B)

- The counter can be stopped by setting TAUJnTT.TAUJnTTm to 1, which in turn sets TAUJnTE.TAUJnTEm to 0.
- TAUJnCNTm stops and retains the current value.
- If the counter is stopped, valid TAUJnTTINm input edges are ignored.
- The counter can be restarted by setting TAUJnTS.TAUJnTSm to 1. TAUJnCNTm restarts counting from 0000 0000_H.

14.13 Synchronous Channel Functions

This section describes about the PWM output function which generates PWM signals at a regular interval. For the overview of the synchronous channel operation, see Section 14.3, Functional Description.

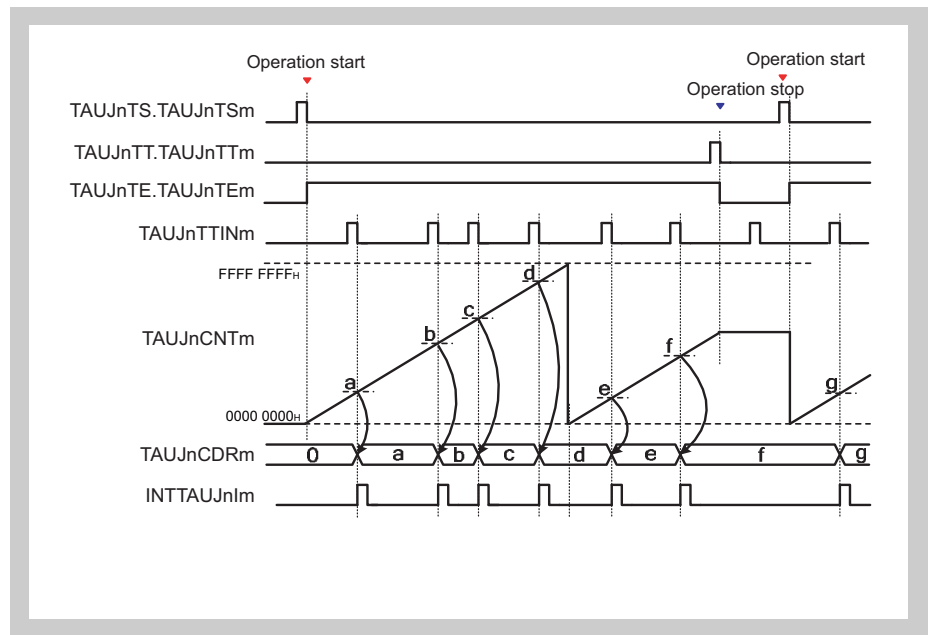
14.13.1 PWM Output Functions

(1) Overview

Summary	This function generates multiple PWM outputs by using a master and multiple slave channels. It enables the pulse cycle (frequency) and the duty of the TAUJnTTOUTm to be set. The pulse cycle is set in the master channel. The duty is set in the slave channel.
Prerequisites	<ul style="list-style-type: none"> • Two channels • The operating mode for master channels should be set to interval timer mode. (See Table 14-38, TAUJnCMORm Settings for Master Channels of PWM Output Function.) • The operating mode for slave channels should be set to one-count mode. (See Table 14-41, TAUJnCMORm Settings for Slave Channels of PWM Output Function.) • TAUJnTTOUTm is not used with the master channels of this function. • The channel output mode for slave channels should be set to synchronous channel output mode 1 (See Table 14-8, Channel Output Modes).
Functional description	<p>The counters are enabled by setting the channel trigger bits (TAUJnTS.TAUJnTSm) to 1. This sets TAUJnTE.TAUJnTEm = 1, enabling count operation. The current value of TAUJnCDRm is loaded into TAUJnCNTm and the counters start to count down from these values. PWM output is implemented by generating INTTAUJnIm on the master channel and setting/resetting TAUJnTTOUTm (slave).</p> <ul style="list-style-type: none"> • Master channel <p>When the counter of the master channel reaches 0000 0000_H and pulse cycle time has elapsed, INTTAUJnIm is generated. The counter reloads the TAUJnCDRm value and counts down.</p> • Slave channel <p>The INTTAUJnIm on master channel triggers the counter operation on slave channels. The current value of TAUJnCDRm (slave) is loaded into TAUJnCNTm (slave) and the counter starts to count down from this value. The TAUJnTTOUTm signal is set to the active level.</p> <p>When the counter reaches 0000 0000_H, i.e. duty time has elapsed, INTTAUJnIm is generated and the TAUJnTTOUTm signal is set to the inactive level. The counter returns to FFFF FFFF_H and awaits the next INTTAUJnIm (the start of the next pulse cycle) of the master channel.</p> <p>The counter can be stopped by setting TAUJnTT.TAUJnTTm to 1 for the master and slave channels, which in turn sets TAUJnTE.TAUJnTEm to 0. TAUJnCNTm and TAUJnTTOUTm of master and slave channels stop but retain their values. The counters can be restarted by setting TAUJnTS.TAUJnTSm to 1.</p>
Conditions	Simultaneous rewrite can be used with this function. See Section 14.7, Simultaneous Rewrite.

(2) Equation

Pulse cycle = (TAUJnCDRm (master) + 1) × count clock cycle

Duty cycle [%] = (TAUJnCDRm (slave) / (TAUJnCDRm (master) + 1) × 100

– Duty cycle = 0 %

TAUJnCDRm (slave) = 0000 0000_H

– Duty cycle = 100 %

TAUJnCDRm (slave) ≥ TAUJnCDRm (master) + 1

(3) Block diagram and general timing diagram

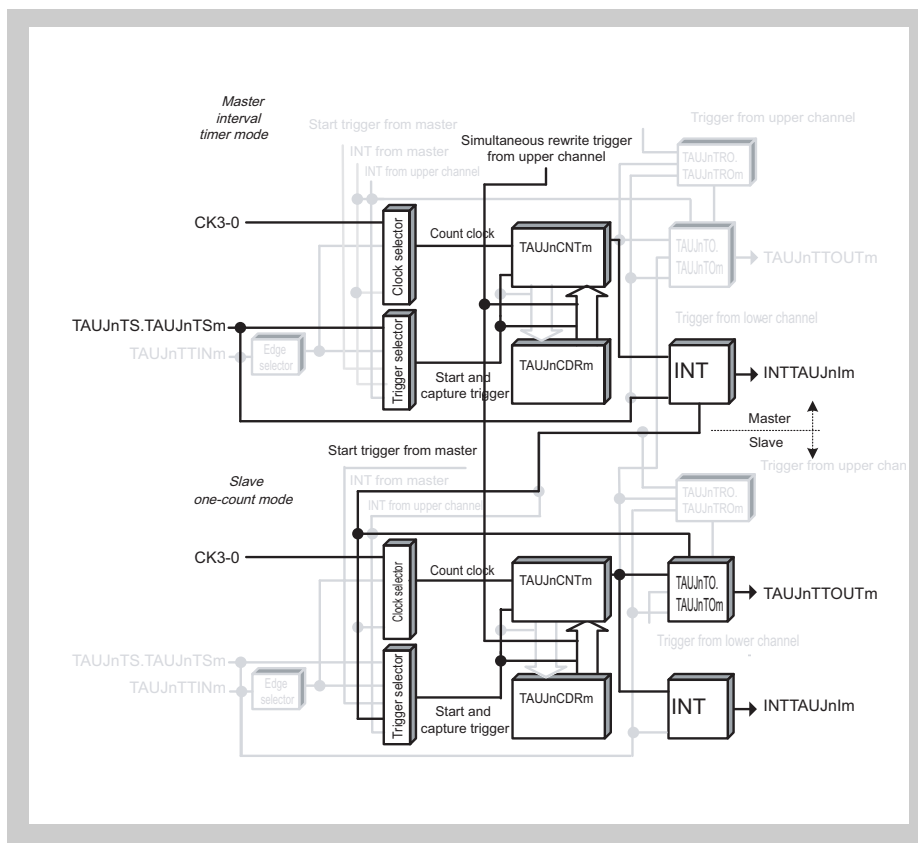

Figure 14-39 Block Diagram of PWM Output Function

The following settings apply to the general timing diagram.

- Slave channel: Positive logic (TAUJnTOL.TAUJnTOLm = 0)

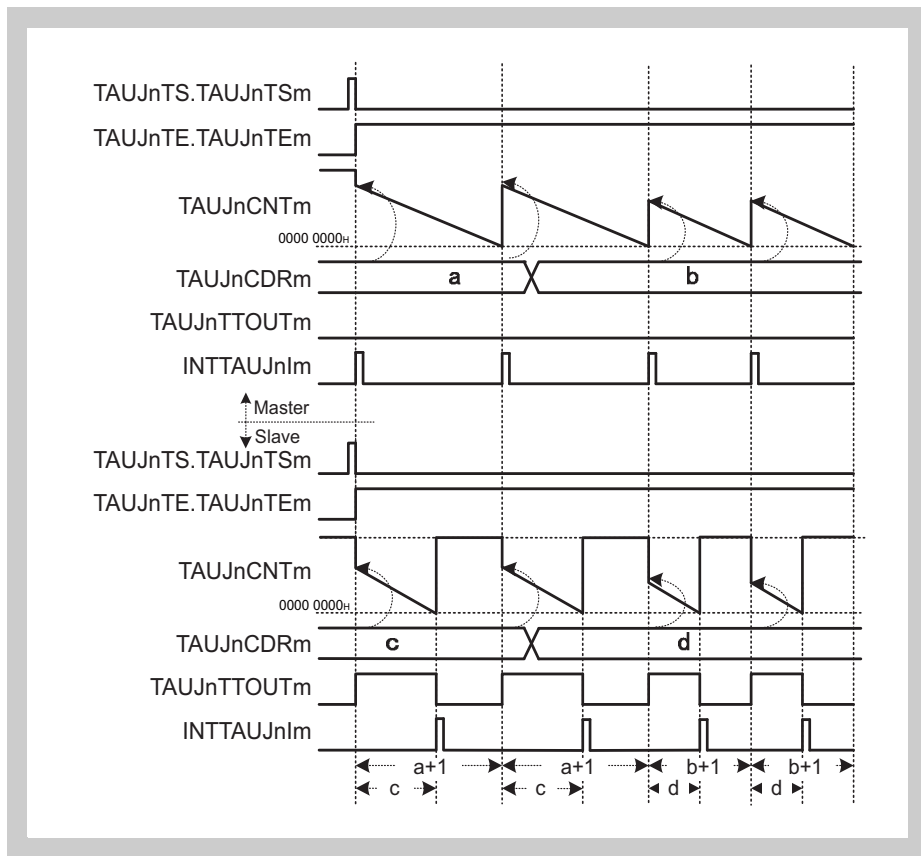

Figure 14-40 General Timing Diagram of PWM Output Function

Note The interval between the slave channel starting to count and an interrupt being generated is the value of corresponding TAUJnCDRm, whereas for the master channel the interval is the corresponding TAUJnCDRm + 1.

(4) Register settings for master channels

(a) TAUJnCMORM for master channels

15	14	13	12	11	10	9	8	7	6	5	4	3	2	1	0
TAUJnCKS [1:0]	TAUJnCCS [1:0]	TAUJnMAS	TAUJnSTS[2:0]			TAUJnCOS [1:0]		-	TAUJnMD[4:1]				TAUJnMD0		

Table 14-38 TAUJnCMORM Settings for Master Channels of PWM Output Function

Bit Name	Setting
TAUJnCKS[1:0]	Selects a sampling clock 00: Prescaler output CK0 01: Prescaler output CK1 10: Prescaler output CK2 11: Prescaler output CK3 TAUJnCKS[1:0] bits of master and slave channels should have the same value
TAUJnCCS[1:0]	00: Sampling clock is used as a count clock
TAUJnMAS	1: Channel is a master channel.
TAUJnSTS[2:0]	000: Triggers the counter by software
TAUJnCOS[1:0]	00: Unused. Set to 00
TAUJnMD[4:1]	0000: Interval timer mode
TAUJnMD0	1: INTTAUJnIm is generated at the beginning of operation

(b) TAUJnCMURm for master channels of PWM Output

7	6	5	4	3	2	1	0
-						TAUJnTIS[1:0]	

Table 14-39 TAUJnCMURm Settings for Master Channels of PWM Output Function

Bit Name	Setting
TAUJnTIS[1:0]	00: Unused. Set to 00

(c) Channel output mode for master channels

The channel output mode is not used with this function. However, this mode can be used with another function or in independent channel output mode controlled by software.

(d) Simultaneous rewrite for master channels

Both master and slave channels should have the same simultaneous rewrite settings.

Table 14-40 Simultaneous Rewrite Settings for Master Channels of PWM Output Function

Bit Name	Setting
TAUJnRDE.TAUJnRDEm	1: Enables simultaneous rewrite
TAUJnRDM.TAUJnRDMm	0: Generates a simultaneous rewrite trigger signal when the master channel starts counting

(5) Register settings for slave channels**(a) TAUJnCMORM for slave channels**

15	14	13	12	11	10	9	8	7	6	5	4	3	2	1	0
TAUJnCKS [1:0]	TAUJnCCS [1:0]	TAUJnMAS	TAUJnSTS[2:0]		TAUJnCOS [1:0]	-		TAUJnMD[4:1]				TAUJnMD0			

Table 14-41 TAUJnCMORM Settings for Slave Channels of PWM Output Function

Bit Name	Setting
TAUJnCKS[1:0]	Selects a sampling clock 00: Prescaler output CK0 01: Prescaler output CK1 10: Prescaler output CK2 11: Prescaler output CK3 TAUJnCKS[1:0] bits of master and slave channels should have the same value
TAUJnCCS[1:0]	00: Sampling clock is used as a count clock
TAUJnMAS	0: Channel is a slave channel
TAUJnSTS[2:0]	100: INTTAUJnIm of master channel is a start trigger
TAUJnCOS[1:0]	00: Unused. Set to 00
TAUJnMD[4:1]	0100: One-Count Mode
TAUJnMD0	1: Start trigger is valid during operation

(b) TAUJnCMURm for slave channels

7	6	5	4	3	2	1	0
-						TAUJnTIS[1:0]	

Table 14-42 TAUJnCMURm for Slave Channels

Bit Name	Setting
TAUJnTIS[1:0]	00: Unused. Set to 00

(c) Channel output mode for slave channels**Table 14-43 Control Bit Settings in Synchronous Channel Output Mode 1**

Bit Name	Setting
TAUJnTOE.TAUJnTOEm	1: Enables independent channel output mode
TAUJnTO.TAUJnTOm	0: Low level 1: High level
TAUJnTOM.TAUJnTOMm	1: Synchronous channel operation
TAUJnTOC.TAUJnTOCm	0: Operating mode 1
TAUJnTOL.TAUJnTOLm	0: Positive logic 1: Inverted logic

(d) Simultaneous rewrite for slave channels

Both master and slave channels should have the same simultaneous rewrite settings.

Table 14-44 Simultaneous Rewrite Settings for Slave Channels of the PWM Output Function

Bit Name	Setting
TAUJnRDE.TAUJnRDEm	1: Enables simultaneous rewrite
TAUJnRDM.TAUJnRDMm	0: Generates a simultaneous rewrite trigger signal when the master channel starts counting

(6) Operating procedure for PWM Output Function

Table 14-45 Operating Procedure for PWM Output Function

	Operation	TAUJn Status
Restart ↑	Initial channel setting	Channel operation is stopped.
	Start operation	TAUJnTE.TAUJnTEm (master and slave channels) is set to 1 and the counters of master and slave channels are started. INTTAUJnIm is generated on the master channel and TAUJnTTOUTm (slave) is set.
	During operation	TAUJnCNTm of master channel loads TAUJnCDRm value and counts down. When the counter reaches 0000 0000 _H , <ul style="list-style-type: none"> • INTTAUJnIm (master) occurs. • TAUJnCDRm value is loaded into TAUJnCNTm (master) to continue count operation. • TAUJnCDRm value is loaded into TAUJnCNTm (slave) to start counting down. • TAUJnTTOUTm (slave) is set to the active level. If TAUJnCNTm (slave) reaches 0000 0000 _H , <ul style="list-style-type: none"> • INTTAUJnIm (slave) occurs. • TAUJnTTOUTm (slave) is set to the inactive level.
	Stop operation	TAUJnTE.TAUJnTEm is cleared to 0 and the counters stop. TAUJnCNTm and TAUJnTTOUTm stop, and retain their current values.

(7) Specific timing diagrams

(a) Duty cycle = 0%

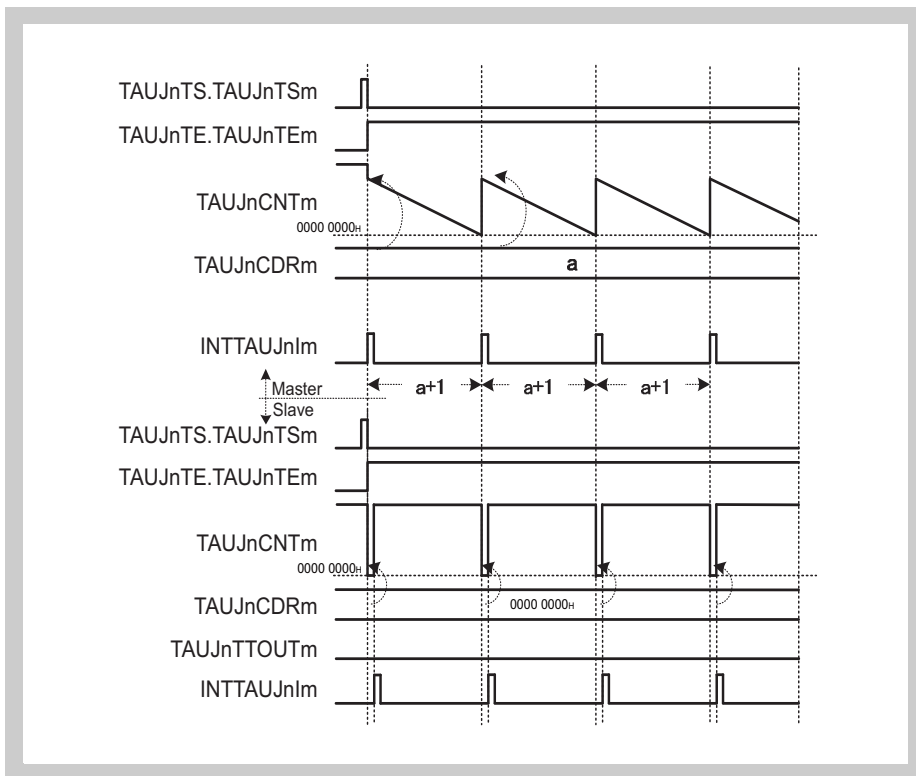

Figure 14-41 TAUJnCDRm (Slave) = 0000 0000_H, Positive Logic (TAUJnTOL.TAUJnTOLm (Slave) = 0)

- Every time the master channel generates an interrupt (INTTAUJnIm), 0000 0000_H is loaded into TAUJnCNTm (slave). Therefore, TAUJnCNTm (slave) cannot start to count and TAUJnTTOUTm remains inactive.
- The value of TAUJnCDRm is loaded into TAUJnCNTm (slave) to generate an interrupt.

(b) Duty cycle = 100%

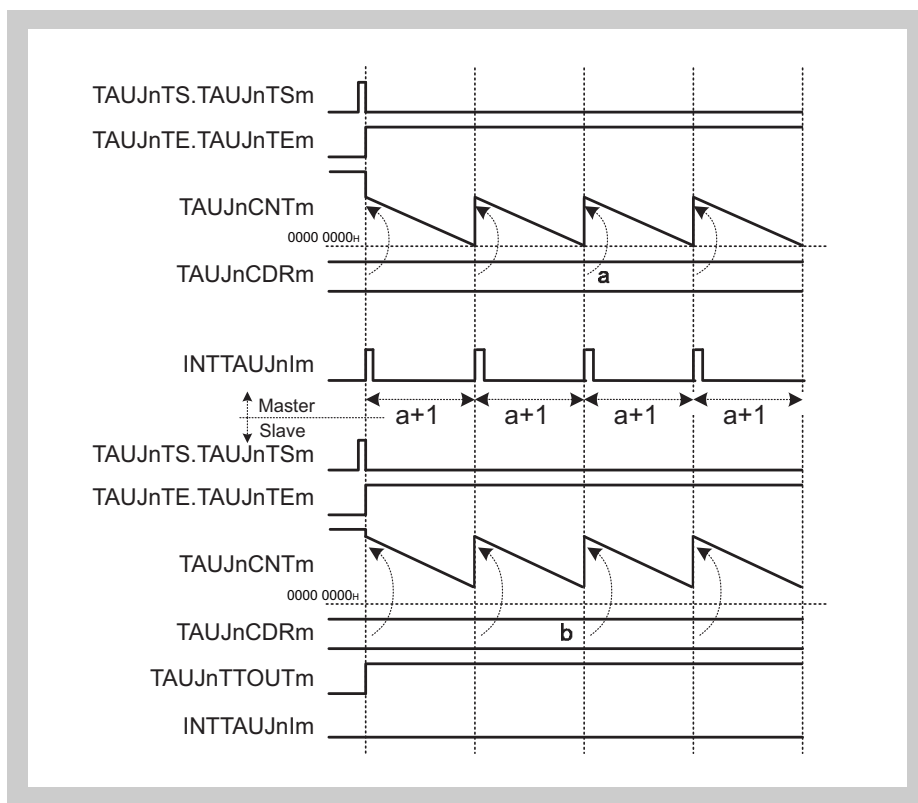

Figure 14-42 TAUJnCDRm (Slave) \geq TAUJnCDRm (Master) + 1, Positive Logic (TAUJnTOL.TAUJnTOLm (Slave) = 0)

- If the TAUJnCDRm (slave) value is greater than the TAUJnCDRm (master) value, no interrupt occurs because the counter of the slave channel does not reach $0000\ 0000_H$. TAUJnTTOUTm remains active.

(c) Operation stop and restart

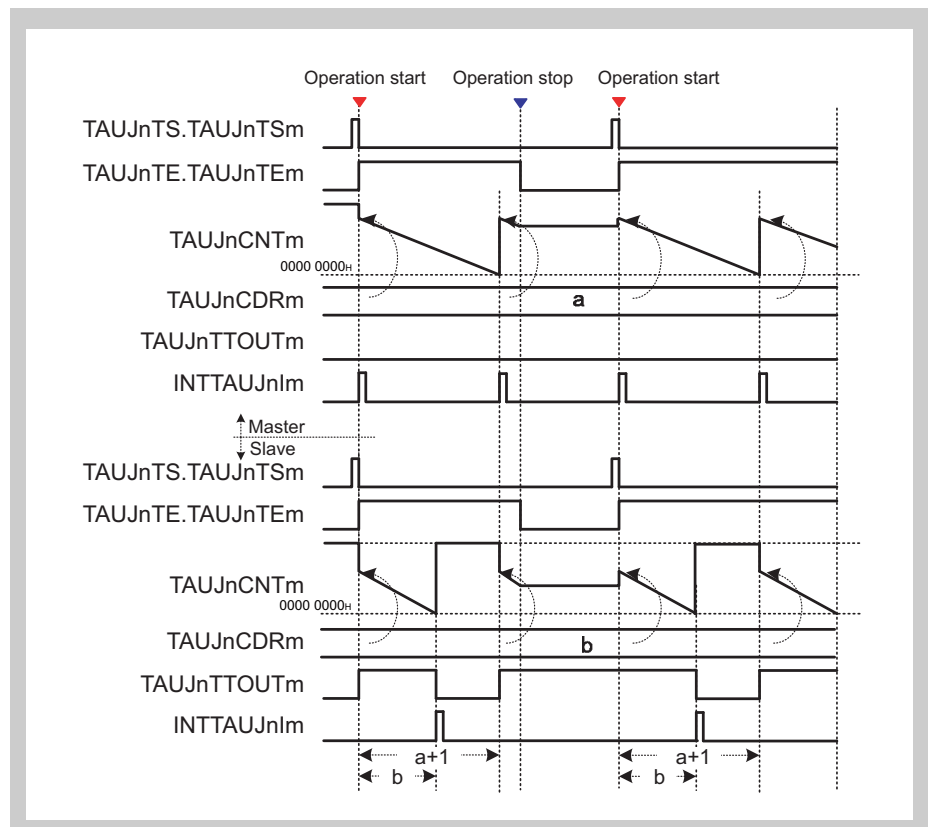

Figure 14-43 Operation Stop and Restart, Positive Logic (TAUJnTOL.TAUJnTOLm (Slave) = 0)

- The counter can be stopped by setting TAUJnTT.TAUJnTTm of master and slave channels to 1. This sets TAUJnTE.TAUJnTEm to 0.
- TAUJnCNTm and TAUJnTTOUTm of every channel stop and retain their current values. No interrupt occurs.
- The counter can be restarted by setting TAUJnTS.TAUJnTSM of master and slave channels to 1. TAUJnCDRm value of master and slave channels is loaded into TAUJnCNTm. The counter starts to count down from this value.

14.14 Registers

This section describes all the registers of the 32-bit TAUJ.

14.14.1 Overview of TAUJn Registers

The TAUJn is controlled and operated by the registers in the following table.

Table 14-46 Overview of TAUJn Registers

Register Name	Abbreviation	Address
TAUJn prescaler registers		
TAUJn prescaler clock select register	TAUJnTPS	<TAUJn_base0> + 90 _H
TAUJn prescaler baud rate setting register	TAUJnBRS	<TAUJn_base0> + 94 _H
TAUJn control registers		
TAUJn channel data register m	TAUJnCDRm	<TAUJn_base1> + m × 4 _H
TAUJn channel counter register m	TAUJnCNTm	<TAUJn_base1> + 10 _H + m × 4 _H
TAUJn channel mode OS register m	TAUJnCMORm	<TAUJn_base0> + 80 _H + m × 4 _H
TAUJn channel mode user register m	TAUJnCMURm	<TAUJn_base1> + 20 _H + m × 4 _H
TAUJn channel status register m	TAUJnCSRm	<TAUJn_base1> + 30 _H + m × 4 _H
TAUJn channel status clear trigger register m	TAUJnCSCm	<TAUJn_base1> + 40 _H + m × 4 _H
TAUJn channel start trigger register	TAUJnTS	<TAUJn_base1> + 54 _H
TAUJn channel enable status register	TAUJnTE	<TAUJn_base1> + 50 _H
TAUJn channel stop trigger register	TAUJnTT	<TAUJn_base1> + 58 _H
TAUJn output registers		
TAUJn channel output enable register	TAUJnTOE	<TAUJn_base1> + 60 _H
TAUJn channel output register	TAUJnTO	<TAUJn_base1> + 5C _H
TAUJn channel output mode register	TAUJnTOM	<TAUJn_base0> + 98 _H
TAUJn channel output configuration register	TAUJnTOC	<TAUJn_base0> + 9C _H
TAUJn channel output active level register	TAUJnTOL	<TAUJn_base1> + 64 _H
TAUJn reload data registers		
TAUJn channel reload data enable register	TAUJnRDE	<TAUJn_base0> + A0 _H
TAUJn channel reload data mode register	TAUJnRDM	<TAUJn_base0> + A4 _H
TAUJn channel reload data trigger register	TAUJnRDT	<TAUJn_base1> + 68 _H
TAUJn channel reload status register	TAUJnRSF	<TAUJn_base1> + 6C _H

Note TAUJn base addresses <TAUJn_base0> and <TAUJn_base1> are defined in the first part of this section "Register Addresses".

Caution If a specified value is described for each register bit, any other value than the specified one should not be written into the corresponding bit.

14.14.2 Details of TAUJn Prescaler Registers

(1) TAUJnTPS - TAUJn prescaler clock select register

This register specifies clocks CK0, CK1, CK2, and CK3_PRE for all channels of the PCLK prescalers. CK3 is generated by dividing CK3_PRE by the factor specified in TAUJnBRS.

Access Readable/writable in 16-bit units.

Address <TAUJn_base0> + 90_H

Initial value FFFF_H

Any reset source triggers initialization.

15	14	13	12	11	10	9	8	7	6	5	4	3	2	1	0
TAUJnPRS3[3:0]				TAUJnPRS2[3:0]				TAUJnPRS1[3:0]				TAUJnPRS0[3:0]			
R/W	R/W	R/W	R/W	R/W	R/W	R/W	R/W	R/W	R/W	R/W	R/W	R/W	R/W	R/W	R/W

Table 14-47 Description of TAUJnTPS Register (1/3)

Bit Position	Bit Name	Function																																		
15 to 12	TAUJnPRS3 [3:0]	<p>Specifies a CK3_PRE clock. The CK3_PRE clock is an input clock of the BRG unit which supplies prescaler output CK3 to all channels.</p> <table border="1"> <thead> <tr> <th>TAUJnPRS3[3:0]</th> <th>CK3_PRE clock</th> </tr> </thead> <tbody> <tr><td>0000_B</td><td>PCLK/2⁰</td></tr> <tr><td>0001_B</td><td>PCLK/2¹</td></tr> <tr><td>0010_B</td><td>PCLK/2²</td></tr> <tr><td>0011_B</td><td>PCLK/2³</td></tr> <tr><td>0100_B</td><td>PCLK/2⁴</td></tr> <tr><td>0101_B</td><td>PCLK/2⁵</td></tr> <tr><td>0110_B</td><td>PCLK/2⁶</td></tr> <tr><td>0111_B</td><td>PCLK/2⁷</td></tr> <tr><td>1000_B</td><td>PCLK/2⁸</td></tr> <tr><td>1001_B</td><td>PCLK/2⁹</td></tr> <tr><td>1010_B</td><td>PCLK/2¹⁰</td></tr> <tr><td>1011_B</td><td>PCLK/2¹¹</td></tr> <tr><td>1100_B</td><td>PCLK/2¹²</td></tr> <tr><td>1101_B</td><td>PCLK/2¹³</td></tr> <tr><td>1110_B</td><td>PCLK/2¹⁴</td></tr> <tr><td>1111_B</td><td>PCLK/2¹⁵</td></tr> </tbody> </table> <p>The above bits are rewritable only when all the counters using CK3 are stopped (TAUJnTE.TAUJnTEm= 0).</p>	TAUJnPRS3[3:0]	CK3_PRE clock	0000 _B	PCLK/2 ⁰	0001 _B	PCLK/2 ¹	0010 _B	PCLK/2 ²	0011 _B	PCLK/2 ³	0100 _B	PCLK/2 ⁴	0101 _B	PCLK/2 ⁵	0110 _B	PCLK/2 ⁶	0111 _B	PCLK/2 ⁷	1000 _B	PCLK/2 ⁸	1001 _B	PCLK/2 ⁹	1010 _B	PCLK/2 ¹⁰	1011 _B	PCLK/2 ¹¹	1100 _B	PCLK/2 ¹²	1101 _B	PCLK/2 ¹³	1110 _B	PCLK/2 ¹⁴	1111 _B	PCLK/2 ¹⁵
TAUJnPRS3[3:0]	CK3_PRE clock																																			
0000 _B	PCLK/2 ⁰																																			
0001 _B	PCLK/2 ¹																																			
0010 _B	PCLK/2 ²																																			
0011 _B	PCLK/2 ³																																			
0100 _B	PCLK/2 ⁴																																			
0101 _B	PCLK/2 ⁵																																			
0110 _B	PCLK/2 ⁶																																			
0111 _B	PCLK/2 ⁷																																			
1000 _B	PCLK/2 ⁸																																			
1001 _B	PCLK/2 ⁹																																			
1010 _B	PCLK/2 ¹⁰																																			
1011 _B	PCLK/2 ¹¹																																			
1100 _B	PCLK/2 ¹²																																			
1101 _B	PCLK/2 ¹³																																			
1110 _B	PCLK/2 ¹⁴																																			
1111 _B	PCLK/2 ¹⁵																																			

Table 14-47 Description of TAUJnTPS Register (2/3)

Bit Position	Bit Name	Function																																		
11 to 8	TAUJnPRS2 [3:0]	<p>Specifies prescaler output CK2.</p> <table border="1"> <thead> <tr> <th>TAUJnPRS2[3:0]</th> <th>Prescaler Output CK2</th> </tr> </thead> <tbody> <tr><td>0000_B</td><td>PCLK/2⁰</td></tr> <tr><td>0001_B</td><td>PCLK/2¹</td></tr> <tr><td>0010_B</td><td>PCLK/2²</td></tr> <tr><td>0011_B</td><td>PCLK/2³</td></tr> <tr><td>0100_B</td><td>PCLK/2⁴</td></tr> <tr><td>0101_B</td><td>PCLK/2⁵</td></tr> <tr><td>0110_B</td><td>PCLK/2⁶</td></tr> <tr><td>0111_B</td><td>PCLK/2⁷</td></tr> <tr><td>1000_B</td><td>PCLK/2⁸</td></tr> <tr><td>1001_B</td><td>PCLK/2⁹</td></tr> <tr><td>1010_B</td><td>PCLK/2¹⁰</td></tr> <tr><td>1011_B</td><td>PCLK/2¹¹</td></tr> <tr><td>1100_B</td><td>PCLK/2¹²</td></tr> <tr><td>1101_B</td><td>PCLK/2¹³</td></tr> <tr><td>1110_B</td><td>PCLK/2¹⁴</td></tr> <tr><td>1111_B</td><td>PCLK/2¹⁵</td></tr> </tbody> </table> <p>The above bits are rewritable only when all the counters using CK2 are stopped (TAUJnTE.TAUJnTEm = 0).</p>	TAUJnPRS2[3:0]	Prescaler Output CK2	0000 _B	PCLK/2 ⁰	0001 _B	PCLK/2 ¹	0010 _B	PCLK/2 ²	0011 _B	PCLK/2 ³	0100 _B	PCLK/2 ⁴	0101 _B	PCLK/2 ⁵	0110 _B	PCLK/2 ⁶	0111 _B	PCLK/2 ⁷	1000 _B	PCLK/2 ⁸	1001 _B	PCLK/2 ⁹	1010 _B	PCLK/2 ¹⁰	1011 _B	PCLK/2 ¹¹	1100 _B	PCLK/2 ¹²	1101 _B	PCLK/2 ¹³	1110 _B	PCLK/2 ¹⁴	1111 _B	PCLK/2 ¹⁵
TAUJnPRS2[3:0]	Prescaler Output CK2																																			
0000 _B	PCLK/2 ⁰																																			
0001 _B	PCLK/2 ¹																																			
0010 _B	PCLK/2 ²																																			
0011 _B	PCLK/2 ³																																			
0100 _B	PCLK/2 ⁴																																			
0101 _B	PCLK/2 ⁵																																			
0110 _B	PCLK/2 ⁶																																			
0111 _B	PCLK/2 ⁷																																			
1000 _B	PCLK/2 ⁸																																			
1001 _B	PCLK/2 ⁹																																			
1010 _B	PCLK/2 ¹⁰																																			
1011 _B	PCLK/2 ¹¹																																			
1100 _B	PCLK/2 ¹²																																			
1101 _B	PCLK/2 ¹³																																			
1110 _B	PCLK/2 ¹⁴																																			
1111 _B	PCLK/2 ¹⁵																																			
7 to 4	TAUJnPRS1 [3:0]	<p>Specifies prescaler output CK1.</p> <table border="1"> <thead> <tr> <th>TAUJnPRS1[3:0]</th> <th>Prescaler Output CK1</th> </tr> </thead> <tbody> <tr><td>0000_B</td><td>PCLK/2⁰</td></tr> <tr><td>0001_B</td><td>PCLK/2¹</td></tr> <tr><td>0010_B</td><td>PCLK/2²</td></tr> <tr><td>0011_B</td><td>PCLK/2³</td></tr> <tr><td>0100_B</td><td>PCLK/2⁴</td></tr> <tr><td>0101_B</td><td>PCLK/2⁵</td></tr> <tr><td>0110_B</td><td>PCLK/2⁶</td></tr> <tr><td>0111_B</td><td>PCLK/2⁷</td></tr> <tr><td>1000_B</td><td>PCLK/2⁸</td></tr> <tr><td>1001_B</td><td>PCLK/2⁹</td></tr> <tr><td>1010_B</td><td>PCLK/2¹⁰</td></tr> <tr><td>1011_B</td><td>PCLK/2¹¹</td></tr> <tr><td>1100_B</td><td>PCLK/2¹²</td></tr> <tr><td>1101_B</td><td>PCLK/2¹³</td></tr> <tr><td>1110_B</td><td>PCLK/2¹⁴</td></tr> <tr><td>1111_B</td><td>PCLK/2¹⁵</td></tr> </tbody> </table> <p>The above bits are rewritable only when all the counters using CK1 are stopped (TAUJnTE.TAUJnTEm = 0).</p>	TAUJnPRS1[3:0]	Prescaler Output CK1	0000 _B	PCLK/2 ⁰	0001 _B	PCLK/2 ¹	0010 _B	PCLK/2 ²	0011 _B	PCLK/2 ³	0100 _B	PCLK/2 ⁴	0101 _B	PCLK/2 ⁵	0110 _B	PCLK/2 ⁶	0111 _B	PCLK/2 ⁷	1000 _B	PCLK/2 ⁸	1001 _B	PCLK/2 ⁹	1010 _B	PCLK/2 ¹⁰	1011 _B	PCLK/2 ¹¹	1100 _B	PCLK/2 ¹²	1101 _B	PCLK/2 ¹³	1110 _B	PCLK/2 ¹⁴	1111 _B	PCLK/2 ¹⁵
TAUJnPRS1[3:0]	Prescaler Output CK1																																			
0000 _B	PCLK/2 ⁰																																			
0001 _B	PCLK/2 ¹																																			
0010 _B	PCLK/2 ²																																			
0011 _B	PCLK/2 ³																																			
0100 _B	PCLK/2 ⁴																																			
0101 _B	PCLK/2 ⁵																																			
0110 _B	PCLK/2 ⁶																																			
0111 _B	PCLK/2 ⁷																																			
1000 _B	PCLK/2 ⁸																																			
1001 _B	PCLK/2 ⁹																																			
1010 _B	PCLK/2 ¹⁰																																			
1011 _B	PCLK/2 ¹¹																																			
1100 _B	PCLK/2 ¹²																																			
1101 _B	PCLK/2 ¹³																																			
1110 _B	PCLK/2 ¹⁴																																			
1111 _B	PCLK/2 ¹⁵																																			

Table 14-47 Description of TAUJnTPS Register (3/3)

Bit Position	Bit Name	Function																																		
3 to 0	TAUJnPRS0 [3:0]	Specifies prescaler output CK0. <table border="1" data-bbox="571 338 1385 1061"> <thead> <tr> <th>TAUJnPRS0[3:0]</th> <th>Prescaler Output CK0</th> </tr> </thead> <tbody> <tr><td>0000_B</td><td>PCLK/2⁰</td></tr> <tr><td>0001_B</td><td>PCLK/2¹</td></tr> <tr><td>0010_B</td><td>PCLK/2²</td></tr> <tr><td>0011_B</td><td>PCLK/2³</td></tr> <tr><td>0100_B</td><td>PCLK/2⁴</td></tr> <tr><td>0101_B</td><td>PCLK/2⁵</td></tr> <tr><td>0110_B</td><td>PCLK/2⁶</td></tr> <tr><td>0111_B</td><td>PCLK/2⁷</td></tr> <tr><td>1000_B</td><td>PCLK/2⁸</td></tr> <tr><td>1001_B</td><td>PCLK/2⁹</td></tr> <tr><td>1010_B</td><td>PCLK/2¹⁰</td></tr> <tr><td>1011_B</td><td>PCLK/2¹¹</td></tr> <tr><td>1100_B</td><td>PCLK/2¹²</td></tr> <tr><td>1101_B</td><td>PCLK/2¹³</td></tr> <tr><td>1110_B</td><td>PCLK/2¹⁴</td></tr> <tr><td>1111_B</td><td>PCLK/2¹⁵</td></tr> </tbody> </table> <p>The above bits are rewritable only when all the counters using CK0 are stopped (TAUJnTE.TAUJnTEm = 0).</p>	TAUJnPRS0[3:0]	Prescaler Output CK0	0000 _B	PCLK/2 ⁰	0001 _B	PCLK/2 ¹	0010 _B	PCLK/2 ²	0011 _B	PCLK/2 ³	0100 _B	PCLK/2 ⁴	0101 _B	PCLK/2 ⁵	0110 _B	PCLK/2 ⁶	0111 _B	PCLK/2 ⁷	1000 _B	PCLK/2 ⁸	1001 _B	PCLK/2 ⁹	1010 _B	PCLK/2 ¹⁰	1011 _B	PCLK/2 ¹¹	1100 _B	PCLK/2 ¹²	1101 _B	PCLK/2 ¹³	1110 _B	PCLK/2 ¹⁴	1111 _B	PCLK/2 ¹⁵
TAUJnPRS0[3:0]	Prescaler Output CK0																																			
0000 _B	PCLK/2 ⁰																																			
0001 _B	PCLK/2 ¹																																			
0010 _B	PCLK/2 ²																																			
0011 _B	PCLK/2 ³																																			
0100 _B	PCLK/2 ⁴																																			
0101 _B	PCLK/2 ⁵																																			
0110 _B	PCLK/2 ⁶																																			
0111 _B	PCLK/2 ⁷																																			
1000 _B	PCLK/2 ⁸																																			
1001 _B	PCLK/2 ⁹																																			
1010 _B	PCLK/2 ¹⁰																																			
1011 _B	PCLK/2 ¹¹																																			
1100 _B	PCLK/2 ¹²																																			
1101 _B	PCLK/2 ¹³																																			
1110 _B	PCLK/2 ¹⁴																																			
1111 _B	PCLK/2 ¹⁵																																			

(2) TAUJnBRS - TAUJn prescaler baud rate setting register

This register specifies the division factor of prescaler output CK3.

CK3 is generated by dividing CK3_PRE by the factor specified in this register plus one. The PCLK prescaler for CK3_PRE is specified in TAUJnTPS.PRS3[3:0].

Access Readable/writable in 8-bit units.

Address <TAUJn_base0> + 94_H

Initial value 00_H

Any reset source triggers initialization.

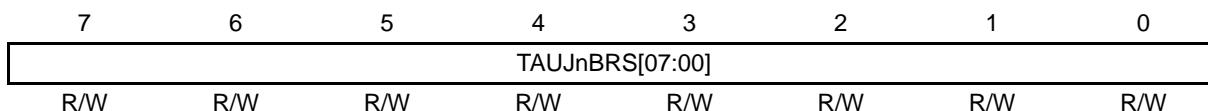

Table 14-48 Description of TAUJnBRS Register

Bit Position	Bit Name	Function																
7 to 0	TAUJnBRS [07:00]	Specifies a CK3_PRE clock division factor for generating prescaler output CK3. <table border="1" style="width: 100%; border-collapse: collapse; margin-top: 5px;"> <thead> <tr style="background-color: #cccccc;"> <th style="width: 50%;">TAUJnBRS[07:00]</th> <th style="width: 50%;">Prescaler Output CK3</th> </tr> </thead> <tbody> <tr> <td>0000 0000_B</td> <td>CK3_PRE / 1</td> </tr> <tr> <td>0000 0001_B</td> <td>CK3_PRE / 2</td> </tr> <tr> <td>0000 0010_B</td> <td>CK3_PRE / 3</td> </tr> <tr> <td>0000 0011_B</td> <td>CK3_PRE / 4</td> </tr> <tr> <td>...</td> <td>...</td> </tr> <tr> <td>1111 1110_B</td> <td>CK3_PRE / 255</td> </tr> <tr> <td>1111 1111_B</td> <td>CK3_PRE / 256</td> </tr> </tbody> </table>	TAUJnBRS[07:00]	Prescaler Output CK3	0000 0000 _B	CK3_PRE / 1	0000 0001 _B	CK3_PRE / 2	0000 0010 _B	CK3_PRE / 3	0000 0011 _B	CK3_PRE / 4	1111 1110 _B	CK3_PRE / 255	1111 1111 _B	CK3_PRE / 256
TAUJnBRS[07:00]	Prescaler Output CK3																	
0000 0000 _B	CK3_PRE / 1																	
0000 0001 _B	CK3_PRE / 2																	
0000 0010 _B	CK3_PRE / 3																	
0000 0011 _B	CK3_PRE / 4																	
...	...																	
1111 1110 _B	CK3_PRE / 255																	
1111 1111 _B	CK3_PRE / 256																	

14.14.3 Details of TAUJn Control Registers

(1) TAUJnCDRm - TAUJn channel data register m

This register functions either as a compare register or as a capture register, depending on the operating mode specified in TAUJnCMORm.TAUJnMD[4:1].

Access Readable/writable in 32-bit units.

- Readable in capture mode. Any write operation is ignored.
- Readable/writable in compare mode.

Address <TAUJn_base1> + m × 4_H

Initial value 0000 0000_H

Any reset source triggers initialization.

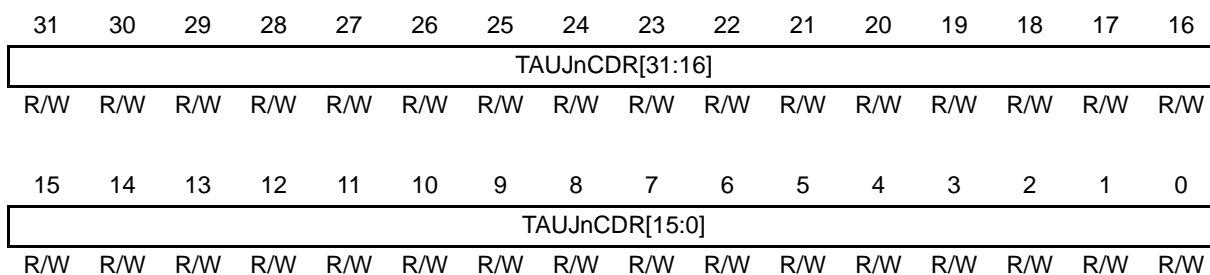

Table 14-49 Description of TAUJnCDRm Register

Bit Position	Bit Name	Function
31 to 0	TAUJnCDR [31:0]	Data register for capture/compare values

(2) TAUJnCNTm - TAUJn channel counter register m

This is a channel m counter register.

Access Readable in 32-bit units.

Address <TAUJn_base1> + 10_H + m × 4_H

Initial value 0000 0000_H or FFFF FFFF_H

The initial value depends on the operating mode. See Table 14-51, TAUJnCNTm Read Values after Counter Is Re-enabled. Any reset source triggers initialization.

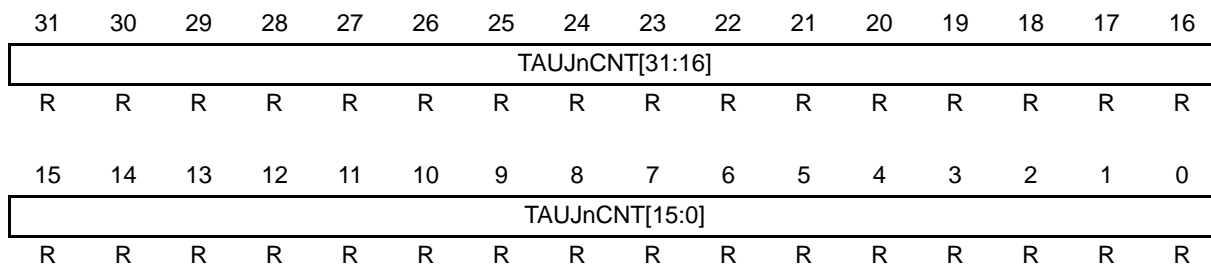

Table 14-50 Description of TAUJnCNTm Register

Bit Position	Bit Name	Function
31 to 0	TAUJnCNT [31:0]	32-bit counter value

The read value depends on a counter, an operating mode change, or TAUJnTS.TAUJnTSM/TAUJnTT.TAUJnTTm bit value.

The initial counter read value depends on the operating mode and how the counter is stopped.

- By a reset
- By a counter stop trigger (TAUJnTT.TAUJnTTm = 1)

The following table lists the initial counter read values after the counter is stopped (TAUJnTE.TAUJnTEm = 0) and re-enabled (TAUJnTS.TAUJnTSM = 1).

The table also contains the counter read value one count after the counter is enabled (TAUJnTS.TAUJnTSM = 1) with the counter waiting for a start trigger.

Table 14-51 TAUJnCNTm Read Values after Counter Is Re-enabled

Mode Name	Count Method (Up/Down)	TAUJnCNTm Value		
		After Changing Operating Mode after Reset	After Stop Trigger	After One Count
Interval timer mode	Count-down	FFFF FFFF _H	Stop value	-
Capture mode	Count-up	0000 0000 _H	Stop value	-
One-count mode	Count-down	FFFF FFFF _H	Stop value	FFFF FFFF _H
Capture and one-count mode	Count-up	0000 0000 _H	Stop value	Capture value + 1 (TAUJnCDRm)
Count capture mode	Count-up	0000 0000 _H	Stop value	-
Capture and gate count mode	Count-up	0000 0000 _H	Stop value	Stop value

Note If operating mode is changed while the counter is stopped, the initial counter value after a counter restart becomes undefined. Operating mode can be changed by the TAUJnCMORm.TAUJnMD[4:0] register.

(3) TAUJnCMORm - TAUJn channel mode OS register m

This register controls channel m operation.

Access Readable/writable in 16-bit units. Writable only when the counter is stopped (TAUJnTE.TAUJnTEm = 0).

Address <TAUJn_base0> + 80_H + m × 4_H

Initial value 0000_H

Any reset source triggers initialization.

15	14	13	12	11	10	9	8	7	6	5	4	3	2	1	0
TAUJnCKS [1:0]	TAUJnCCS [1:0]	TAUJn MAS	TAUJnSTS[2:0]			TAUJnCOS [1:0]		-	TAUJnMD[4:0]						
R/W	R/W	R/W	R/W	R/W	R/W	R/W	R/W	R/W	R/W	R	R/W	R/W	R/W	R/W	R/W

Table 14-52 Description of TAUJnCMORm Register (1/4)

Bit Position	Bit Name	Function															
15, 14	TAUJnCKS [1:0]	<p>Selects a sampling clock, which is used with the TAUJnTTINm input edge detection circuit. Setting of TAUJnCMORm.TAUJnCCS[1:0] bit also allows the sampling clock to serve as a count clock.</p> <table border="1"> <thead> <tr> <th>TAUJn CKS1</th><th>TAUJn CKS0</th><th>Selection of Sampling Clock</th></tr> </thead> <tbody> <tr> <td>0</td><td>0</td><td>Prescaler output CK0</td></tr> <tr> <td>0</td><td>1</td><td>Prescaler output CK1</td></tr> <tr> <td>1</td><td>0</td><td>Prescaler output CK2</td></tr> <tr> <td>1</td><td>1</td><td>Prescaler output CK3</td></tr> </tbody> </table>	TAUJn CKS1	TAUJn CKS0	Selection of Sampling Clock	0	0	Prescaler output CK0	0	1	Prescaler output CK1	1	0	Prescaler output CK2	1	1	Prescaler output CK3
TAUJn CKS1	TAUJn CKS0	Selection of Sampling Clock															
0	0	Prescaler output CK0															
0	1	Prescaler output CK1															
1	0	Prescaler output CK2															
1	1	Prescaler output CK3															
13, 12	TAUJnCCS [1:0]	<p>Selects a count clock for TAUJnCNTm counter.</p> <table border="1"> <thead> <tr> <th>TAUJn CCS1</th><th>TAUJn CCS0</th><th>Selection of Count Clock</th></tr> </thead> <tbody> <tr> <td>0</td><td>0</td><td>Sampling clock specified by TAUJnCMORm.TAUJnCKS[1:0].</td></tr> <tr> <td>0</td><td>1</td><td>Valid edge of TAUJnTTINm input signal</td></tr> <tr> <td>1</td><td>0</td><td rowspan="2">Setting prohibited</td></tr> <tr> <td>1</td><td>1</td></tr> </tbody> </table>	TAUJn CCS1	TAUJn CCS0	Selection of Count Clock	0	0	Sampling clock specified by TAUJnCMORm.TAUJnCKS[1:0].	0	1	Valid edge of TAUJnTTINm input signal	1	0	Setting prohibited	1	1	
TAUJn CCS1	TAUJn CCS0	Selection of Count Clock															
0	0	Sampling clock specified by TAUJnCMORm.TAUJnCKS[1:0].															
0	1	Valid edge of TAUJnTTINm input signal															
1	0	Setting prohibited															
1	1																
11	TAUJnMAS	<p>Specifies whether the channel is a master or slave channel during synchronous channel operation. 0: Slave 1: Master This bit setting is valid only for even channels (CHm_even). Odd channels are fixed to 0.</p>															

Table 14-52 Description of TAUJnCMORm Register (2/4)

Bit Position	Bit Name	Function																																				
10 to 8	TAUJnSTS [2:0]	<p>Selects an external start trigger.</p> <table border="1"> <thead> <tr> <th>TAUJnSTS2</th> <th>TAUJnSTS1</th> <th>TAUJnSTS0</th> <th>Functional Description</th> </tr> </thead> <tbody> <tr> <td>0</td> <td>0</td> <td>0</td> <td>Software trigger</td> </tr> <tr> <td>0</td> <td>0</td> <td>1</td> <td>Valid edge of TAUJnTTINm input signal, which is specified by TAUJnCMURm.TAUJnTIS[1:0].</td> </tr> <tr> <td>0</td> <td>1</td> <td>0</td> <td>Valid edge of TAUJnTTINm input signal is used as a start trigger and the reverse edge as a stop trigger.</td> </tr> <tr> <td>0</td> <td>1</td> <td>1</td> <td>Setting prohibited</td> </tr> <tr> <td>1</td> <td>0</td> <td>0</td> <td>INTTAUJnlm of master channel</td> </tr> <tr> <td>1</td> <td>0</td> <td>1</td> <td>Setting prohibited</td> </tr> <tr> <td>1</td> <td>1</td> <td>0</td> <td></td> </tr> <tr> <td>1</td> <td>1</td> <td>1</td> <td></td> </tr> </tbody> </table>	TAUJnSTS2	TAUJnSTS1	TAUJnSTS0	Functional Description	0	0	0	Software trigger	0	0	1	Valid edge of TAUJnTTINm input signal, which is specified by TAUJnCMURm.TAUJnTIS[1:0].	0	1	0	Valid edge of TAUJnTTINm input signal is used as a start trigger and the reverse edge as a stop trigger.	0	1	1	Setting prohibited	1	0	0	INTTAUJnlm of master channel	1	0	1	Setting prohibited	1	1	0		1	1	1	
TAUJnSTS2	TAUJnSTS1	TAUJnSTS0	Functional Description																																			
0	0	0	Software trigger																																			
0	0	1	Valid edge of TAUJnTTINm input signal, which is specified by TAUJnCMURm.TAUJnTIS[1:0].																																			
0	1	0	Valid edge of TAUJnTTINm input signal is used as a start trigger and the reverse edge as a stop trigger.																																			
0	1	1	Setting prohibited																																			
1	0	0	INTTAUJnlm of master channel																																			
1	0	1	Setting prohibited																																			
1	1	0																																				
1	1	1																																				

Table 14-52 Description of TAUJnCMORm Register (3/4)

Bit Position	Bit Name	Function																				
7, 6	TAUJnCOS [1:0]	<p>Specifies the timing for updating capture register TAUJnCDRm and overflow flag TAUJnCSRm.TAUJnOVF of channel m. These bits are valid only when channel m is in capture mode.</p> <table border="1"> <thead> <tr> <th>TAUJn COS1</th> <th>TAUJn COS0</th> <th>TAUJnCDRm</th> <th>TAUJnCSRm.TAUJnOVF</th> </tr> </thead> <tbody> <tr> <td>0</td> <td>0</td> <td>Updated when valid edge of TAUJnTTINm input is detected.</td> <td> <p>Updated (cleared or set) when valid edge of TAUJnTTINm input is detected:</p> <ul style="list-style-type: none"> Set TAUJnCSRm.TAUJnOVF if a counter overflow has occurred since the last valid edge was detected. Clear TAUJnCSRm.TAUJnOVF if no counter overflow has occurred since the last valid edge was detected. </td> </tr> <tr> <td>0</td> <td>1</td> <td></td> <td>Set when a counter overflow occurs and cleared by setting TAUJnCSCm.TAUJnCLOV to 1.</td> </tr> <tr> <td>1</td> <td>0</td> <td>Updated when valid edge of TAUJnTTINm input is detected and when a counter overflow occurs.</td> <td>No setting</td> </tr> <tr> <td>1</td> <td>1</td> <td> <ul style="list-style-type: none"> Detection of valid edge of TAUJnTTINm input: The counter value is written into TAUJnCDRm. Occurrence of overflow: FFFF FFFF_H is loaded into TAUJnCDRm. Detection of the next valid edge of TAUJnTTINm is ignored. </td> <td>Set when a counter overflow occurs and cleared by setting TAUJnCSCm.TAUJnCLOV to 1.</td> </tr> </tbody> </table>	TAUJn COS1	TAUJn COS0	TAUJnCDRm	TAUJnCSRm.TAUJnOVF	0	0	Updated when valid edge of TAUJnTTINm input is detected.	<p>Updated (cleared or set) when valid edge of TAUJnTTINm input is detected:</p> <ul style="list-style-type: none"> Set TAUJnCSRm.TAUJnOVF if a counter overflow has occurred since the last valid edge was detected. Clear TAUJnCSRm.TAUJnOVF if no counter overflow has occurred since the last valid edge was detected. 	0	1		Set when a counter overflow occurs and cleared by setting TAUJnCSCm.TAUJnCLOV to 1.	1	0	Updated when valid edge of TAUJnTTINm input is detected and when a counter overflow occurs.	No setting	1	1	<ul style="list-style-type: none"> Detection of valid edge of TAUJnTTINm input: The counter value is written into TAUJnCDRm. Occurrence of overflow: FFFF FFFF_H is loaded into TAUJnCDRm. Detection of the next valid edge of TAUJnTTINm is ignored. 	Set when a counter overflow occurs and cleared by setting TAUJnCSCm.TAUJnCLOV to 1.
TAUJn COS1	TAUJn COS0	TAUJnCDRm	TAUJnCSRm.TAUJnOVF																			
0	0	Updated when valid edge of TAUJnTTINm input is detected.	<p>Updated (cleared or set) when valid edge of TAUJnTTINm input is detected:</p> <ul style="list-style-type: none"> Set TAUJnCSRm.TAUJnOVF if a counter overflow has occurred since the last valid edge was detected. Clear TAUJnCSRm.TAUJnOVF if no counter overflow has occurred since the last valid edge was detected. 																			
0	1		Set when a counter overflow occurs and cleared by setting TAUJnCSCm.TAUJnCLOV to 1.																			
1	0	Updated when valid edge of TAUJnTTINm input is detected and when a counter overflow occurs.	No setting																			
1	1	<ul style="list-style-type: none"> Detection of valid edge of TAUJnTTINm input: The counter value is written into TAUJnCDRm. Occurrence of overflow: FFFF FFFF_H is loaded into TAUJnCDRm. Detection of the next valid edge of TAUJnTTINm is ignored. 	Set when a counter overflow occurs and cleared by setting TAUJnCSCm.TAUJnCLOV to 1.																			

Table 14-52 Description of TAUJnCMORm Register (4/4)

Bit Position	Bit Name	Function																																																																																										
4 to 0	TAUJnMD [4:0]	Specifies operating mode.																																																																																										
<table border="1"> <thead> <tr> <th>TAUJn MD4</th> <th>TAUJn MD3</th> <th>TAUJn MD2</th> <th>TAUJn MD1</th> <th>TAUJn MD0</th> <th>Functional description</th> </tr> </thead> <tbody> <tr> <td>0</td> <td>0</td> <td>0</td> <td>0</td> <td>1/0</td> <td>Interval timer mode</td> </tr> <tr> <td>0</td> <td>0</td> <td>0</td> <td>1</td> <td>1/0</td> <td>Setting prohibited</td> </tr> <tr> <td>0</td> <td>0</td> <td>1</td> <td>0</td> <td>1/0</td> <td>Capture mode</td> </tr> <tr> <td>0</td> <td>0</td> <td>1</td> <td>1</td> <td>1/0</td> <td>Setting prohibited</td> </tr> <tr> <td>0</td> <td>1</td> <td>0</td> <td>0</td> <td>1/0</td> <td>One-count mode</td> </tr> <tr> <td>0</td> <td>1</td> <td>0</td> <td>1</td> <td>1/0</td> <td>Setting prohibited</td> </tr> <tr> <td>0</td> <td>1</td> <td>1</td> <td>0</td> <td>0</td> <td>Capture and one-count mode</td> </tr> <tr> <td>0</td> <td>1</td> <td>1</td> <td>1</td> <td>1/0</td> <td>Setting prohibited</td> </tr> <tr> <td>1</td> <td>0</td> <td>0</td> <td>0</td> <td></td> <td></td> </tr> <tr> <td>1</td> <td>0</td> <td>0</td> <td>1</td> <td></td> <td></td> </tr> <tr> <td>1</td> <td>0</td> <td>1</td> <td>0</td> <td></td> <td></td> </tr> <tr> <td>1</td> <td>0</td> <td>1</td> <td>1</td> <td>1/0</td> <td>Count capture mode</td> </tr> <tr> <td>1</td> <td>1</td> <td>0</td> <td>0</td> <td>1/0</td> <td>Setting prohibited</td> </tr> <tr> <td>1</td> <td>1</td> <td>0</td> <td>1</td> <td>0</td> <td>Capture and gate count mode</td> </tr> </tbody> </table>			TAUJn MD4	TAUJn MD3	TAUJn MD2	TAUJn MD1	TAUJn MD0	Functional description	0	0	0	0	1/0	Interval timer mode	0	0	0	1	1/0	Setting prohibited	0	0	1	0	1/0	Capture mode	0	0	1	1	1/0	Setting prohibited	0	1	0	0	1/0	One-count mode	0	1	0	1	1/0	Setting prohibited	0	1	1	0	0	Capture and one-count mode	0	1	1	1	1/0	Setting prohibited	1	0	0	0			1	0	0	1			1	0	1	0			1	0	1	1	1/0	Count capture mode	1	1	0	0	1/0	Setting prohibited	1	1	0	1	0	Capture and gate count mode
TAUJn MD4	TAUJn MD3	TAUJn MD2	TAUJn MD1	TAUJn MD0	Functional description																																																																																							
0	0	0	0	1/0	Interval timer mode																																																																																							
0	0	0	1	1/0	Setting prohibited																																																																																							
0	0	1	0	1/0	Capture mode																																																																																							
0	0	1	1	1/0	Setting prohibited																																																																																							
0	1	0	0	1/0	One-count mode																																																																																							
0	1	0	1	1/0	Setting prohibited																																																																																							
0	1	1	0	0	Capture and one-count mode																																																																																							
0	1	1	1	1/0	Setting prohibited																																																																																							
1	0	0	0																																																																																									
1	0	0	1																																																																																									
1	0	1	0																																																																																									
1	0	1	1	1/0	Count capture mode																																																																																							
1	1	0	0	1/0	Setting prohibited																																																																																							
1	1	0	1	0	Capture and gate count mode																																																																																							
Mode		Role of TAUJnMD0 Bit																																																																																										
Interval timer mode Capture mode Count capture mode	Specifies whether an INTTAUJnIm signal is generated or not at the beginning of count operation (at the input of start trigger). 0: INTTAUJnIm is not generated. 1: INTTAUJnIm is generated.																																																																																											
One-count mode	Enables/disables detection of a start trigger during counting. 0: Disable 1: Enable																																																																																											
Capture and one-count mode Capture and gate count mode	This bit should be set to 0.																																																																																											

(4) TAUJnCMURm - TAUJn channel mode user register m

This register specifies a type of valid edge detection used for TAUJnTTINm input.

Access Readable/writable in 8-bit units.

Address <TAUJn_base1> + 20_H + m × 4_H

Initial value 00_H

Any reset source triggers initialization.

7	6	5	4	3	2	1	0
-	-	-	-	-	-	TAUJnTIS[1:0]	
R	R	R	R	R	R	R/W	R/W

Table 14-53 Description of TAUJnCMURm Register

Bit Position	Bit Name	Function															
1, 0	TAUJnTIS [1:0]	<p>Specifies a valid edge of TAUJnTTINm input signal.</p> <table border="1"> <thead> <tr> <th>TAUJnTIS1</th> <th>TAUJnTIS0</th> <th>Functional Description</th> </tr> </thead> <tbody> <tr> <td>0</td> <td>0</td> <td>Falling edge</td> </tr> <tr> <td>0</td> <td>1</td> <td>Rising edge</td> </tr> <tr> <td>1</td> <td>0</td> <td>Detection of falling and rising edges (selection of low width measurement) Start trigger: Falling edge Stop trigger (capture): Rising edge</td> </tr> <tr> <td>1</td> <td>1</td> <td>Detection of falling and rising edges (selection of high width measurement) Start trigger: Rising edge Stop trigger (capture): Falling edge</td> </tr> </tbody> </table> <ul style="list-style-type: none"> Edge detection of TAUJnTTINm input signal is based on the sampling clock selected by TAUJnCMORm.TAUJnCKS[1:0]. 	TAUJnTIS1	TAUJnTIS0	Functional Description	0	0	Falling edge	0	1	Rising edge	1	0	Detection of falling and rising edges (selection of low width measurement) Start trigger: Falling edge Stop trigger (capture): Rising edge	1	1	Detection of falling and rising edges (selection of high width measurement) Start trigger: Rising edge Stop trigger (capture): Falling edge
TAUJnTIS1	TAUJnTIS0	Functional Description															
0	0	Falling edge															
0	1	Rising edge															
1	0	Detection of falling and rising edges (selection of low width measurement) Start trigger: Falling edge Stop trigger (capture): Rising edge															
1	1	Detection of falling and rising edges (selection of high width measurement) Start trigger: Rising edge Stop trigger (capture): Falling edge															

(5) TAUJnCSRm - TAUJn channel status register m

This register indicates the overflow status of channel m.

Access Readable in 8-bit units.

Address <TAUJn_base1> + 30_H + m × 4_H

Initial value 00_H

Any reset source triggers initialization.

7	6	5	4	3	2	1	0
-	-	-	-	-	-	-	TAUJnOVF
R	R	R	R	R	R	R	R

Table 14-54 Description of TAUJnCSRm Register

Bit Position	Bit Name	Function
0	TAUJnOVF	<p>Indicates the counter overflow status:</p> <p>0: No overflow occurs</p> <p>1: Overflow occurs</p> <p>This bit is used only in the following modes:</p> <ul style="list-style-type: none"> • Capture mode • Capture and one-count mode <p>The function of this bit depends on the setting of control bits TAUJnCMORm.TAUJnCOS[1:0].</p>

(6) TAUJnCSCm - TAUJn channel status clear trigger register m

This register is a trigger register for clearing the overflow flag TAUJnCSRm.TAUJnOVF of channel m.

Access Writable in 8-bit units. The read value is always 00_H.

Address <TAUJn_base1> + 40_H + m × 4_H

Initial value 00_H

Any reset source triggers initialization.

7	6	5	4	3	2	1	0
-	-	-	-	-	-	0	TAUJnCLOV
R	R	R	R	R	R	R	W

Table 14-55 Description of TAUJnCSCm Register

Bit Position	Bit Name	Function
0	TAUJnCLOV	Controls a clear operation of the overflow flag (TAUJnCSRm.TAUJnOVF) of channel m. 0: No effect (writing 0 to the bit does not affect the overflow flag, i.e. the TAUJnCSRm.TAUJnOVF bit). 1: Clears the overflow flag TAUJnCSRm.TAUJnOVF

(7) TAUJnTS - TAUJn channel start trigger register

This register enables the counter operation for each channel.

Access Writable in 8-bit units. The read value is always 00_H.

Address <TAUJn_base1> + 54_H

Initial value 00_H

Any reset source triggers initialization.

7	6	5	4	3	2	1	0
-	-	-	-	TAUJnTS 03	TAUJnTS 02	TAUJnTS 01	TAUJnTS 00
W	W	W	W	W	W	W	W

Table 14-56 Description of TAUJnTS Register

Bit Position	Bit Name	Function
3 to 0	TAUJnTSM	Enables the counter operation for channel m: 0: No effect (writing 0 to the bit does not enable counting for channel m). 1: Enables the counter operation and sets TAUJnTE.TAUJnTEm = 1 Only the counter operation is enabled even if TAUJnTE.TAUJnTEm = 1 Whether the counter is started or not depends on the selected of operating mode.

(8) TAUJnTE - TAUJn channel enable status register

This register enables/disables a counter operation.

Access Readable in 8-bit units.

Address <TAUJn_base1> + 50_H

Initial value 00_H

Any reset source triggers initialization.

7	6	5	4	3	2	1	0
-	-	-	-	TAUJnTE 03	TAUJnTE 02	TAUJnTE 01	TAUJnTE 00
R	R	R	R	R	R	R	R

Table 14-57 Description of TAUJnTE Register

Bit Position	Bit Name	Function
3 to 0	TAUJnTE _m	Enables/disables channel m's counter operation. 0: Disables the counter operation 1: Enables the counter operation This bit is set to 1 when trigger input of TAUJnTSST _m (synchronous channel start trigger signal) is detected or when TAUJnTS.TAUJnTS _m is set to 1. This bit is set to 0 when TAUJnTT.TAUJnTT _m is set to 1.

(9) TAUJnTT - TAUJn channel stop trigger register

This register stops the counter operation of each channel.

Access Writable in 8-bit units. The read value is always 00_H.

Address <TAUJn_base1> + 58_H

Initial value 00_H

7	6	5	4	3	2	1	0
-	-	-	-	TAUJnTT 03	TAUJnTT 02	TAUJnTT 01	TAUJnTT 00
W	W	W	W	W	W	W	W

Table 14-58 Description of TAUJnTT Register

Bit Position	Bit Name	Function
3 to 0	TAUJnTT _m	Stops channel m's counter operation. 0: No effect (writing 0 to the bit does not stop counting for channel m). 1: Stops the counter operation and resets TAUJnTE.TAUJnTE _m TAUJnCNT _m , TAUJnTO.TAUJnTO _m , and TAUJnTTOUT _m retain the values provided before the counter is stopped.

14.14.4 Details of TAUJn Output Registers

(1) TAUJnTOE - TAUJn channel output enable register

This register enables/disables independent channel output mode controlled by software.

Access Readable/writable in 8-bit units. Writable only while the counter is stopped (TAUJnTE.TAUJnTEm = 0).

Address <TAUJn_base1> + 60_H

Initial value 00_H

Any reset source triggers initialization.

7	6	5	4	3	2	1	0
-	-	-	-	TAUJnTOE 03	TAUJnTOE 02	TAUJnTOE 01	TAUJnTOE 00
R/W	R/W	R/W	R/W	R/W	R/W	R/W	R/W

Table 14-59 Description of TAUJnTOE Register

Bit Position	Bit Name	Function
3 to 0	TAUJnTOEm	Enables/disables the independent timer output function: 0: Disables the independent timer output function (controlled by software) 1: Enables the independent timer output function

Note The output from TAUJnTTOUTm pin is controlled by TAUJnTO.TAUJnTOM (controlled by software).

(2) TAUJnTOM - TAUJn channel output mode register

This register specifies output mode of each channel.

Access Readable/writable in 8-bit units. Writable only while the counter is stopped (TAUJnTE.TAUJnTEm = 0).

Address <TAUJn_base0> + 98_H

Initial value 00_H

Any reset source triggers initialization.

7	6	5	4	3	2	1	0
-	-	-	-	TAUJnTOM 03	TAUJnTOM 02	TAUJnTOM 01	TAUJnTOM 00
R/W	R/W	R/W	R/W	R/W	R/W	R/W	R/W

Table 14-60 Description of TAUJnTOM Register

Bit Position	Bit Name	Function
3 to 0	TAUJnTOMm	Specifies output mode. 0: Independent channel operation 1: Synchronous channel operation As described in Table 14-8, Channel Output Modes, output mode specification depends on the setting of output control bit of each channel.

(3) TAUJnTOC - TAUJn channel output configuration register

This register specifies output mode of each channel in combination with TAUJnTOMm.

Access Readable/writable in 8-bit units. Writable only while the counter is stopped (TAUJnTE.TAUJnTEm = 0).

Address <TAUJn_base0> + 9C_H

Initial value 00_H

Any reset source triggers initialization.

7	6	5	4	3	2	1	0
-	-	-	-	TAUJnTOC 03	TAUJnTOC 02	TAUJnTOC 01	TAUJnTOC 00
R/W	R/W	R/W	R/W	R/W	R/W	R/W	R/W

Table 14-61 Description of TAUJnTOC Register

Bit Position	Bit Name	Function
3-0	TAUJn TOCm	Specifies output mode: 0: Operating mode 1 (Toggle mode) 1: Setting prohibited

14.14.5 Details of TAUJn Channel Output Level Registers

(1) TAUJnTO - TAUJn channel output register

This register specifies and reads a TAUJnTTOUTm level.

Access Readable/writable in 8-bit units.

Address <TAUJn_base1> + 5C_H

Initial value 00_H

Any reset source triggers initialization.

7	6	5	4	3	2	1	0
-	-	-	-	TAUJnTO 03	TAUJnTO 02	TAUJnTO 01	TAUJnTO 00
R/W	R/W	R/W	R/W	R/W	R/W	R/W	R/W

Table 14-62 Description of TAUJnTO Register

Bit Position	Bit Name	Function
3 to 0	TAUJnTOM	Specifies and reads a TAUJnTTOUTm level. 0: Low level 1: High level The TAUJnTOM bit is writable when TAUJnTOE.TAUJnTOEm = 0.

(2) TAUJnTOL - TAUJn channel output active level register

This register specifies an output logic for the channel output bit (TAUJnTO.TAUJnTOM).

Access Readable/writable in 8-bit units.

Address <TAUJn_base1> + 64_H

Initial value 00_H

Any reset source triggers initialization.

7	6	5	4	3	2	1	0
-	-	-	-	TAUJnTOL 03	TAUJnTOL 02	TAUJnTOL 01	TAUJnTOL 00
R/W	R/W	R/W	R/W	R/W	R/W	R/W	R/W

Table 14-63 Description of TAUJnTOL Register

Bit Position	Bit Name	Function
3 to 0	TAUJnTOLm	Specifies the output logic of channel m output bit (TAUJnTO.TAUJnTOM). 0: Positive logic (active high) 1: Inverted logic (active low)

14.14.6 Details of TAUJn Reload Data Registers

(1) TAUJnRDE - TAUJn channel reload data enable register

This register enables/disables simultaneous rewrite of the data register TAUJnCDRm/TAUJnTOLm.

Access Readable/writable in 8-bit units. Writable only while the counter is stopped (TAUJnTE.TAUJnTEm = 0).

Address <TAUJn_base0> + A0_H

Initial value 00_H

Any reset source triggers initialization.

7	6	5	4	3	2	1	0
-	-	-	-	TAUJnRDE 03	TAUJnRDE 02	TAUJnRDE 01	TAUJnRDE 00
R/W	R/W	R/W	R/W	R/W	R/W	R/W	R/W

Table 14-64 Description of TAUJnRDE Register

Bit Position	Bit Name	Function
3 to 0	TAUJnRDEm	Enables/disables simultaneous rewrite of the data register of channel m. 0: Disables simultaneous rewrite 1: Enables simultaneous rewrite

(2) TAUJnRDM - TAUJn channel reload data mode register

This register selects the timing for generating a simultaneous rewrite control signal.

Access Readable/writable in 8-bit units. Writable only while the counter is stopped (TAUJnTE.TAUJnTEm = 0).

Address <TAUJn_base0> + A4_H

Initial value 00_H

Any reset source triggers initialization.

7	6	5	4	3	2	1	0
-	-	-	-	TAUJnRDM 03	TAUJnRDM 02	TAUJnRDM 01	TAUJnRDM 00
R/W	R/W	R/W	R/W	R/W	R/W	R/W	R/W

Table 14-65 Description of TAUJnRDM Register

Bit Position	Bit Name	Function
3 to 0	TAUJnRDMm	Selects the timing for generating a simultaneous rewrite trigger signal. 0: When the master channel counter starts counting 1: Setting prohibited These bit settings are applied only when TAUJnRDE.TAUJnRDEm = 1.

(3) TAUJnRDT - TAUJn channel reload data trigger register

This register triggers a simultaneous rewrite pending state.

Access Writable in 8-bit units. The read value is always 00_H.

Address <TAUJn_base1> + 68_H

Initial value 00_H

Any reset source triggers initialization.

7	6	5	4	3	2	1	0
-	-	-	-	TAUJnRDT 03	TAUJnRDT 02	TAUJnRDT 01	TAUJnRDT 00
W	W	W	W	W	W	W	W

Table 14-66 Description of TAUJnRDT Register

Bit Position	Bit Name	Function
3 to 0	TAUJnRDTm	Triggers a simultaneous rewrite pending state: 0: No effect (writing 0 to the bit does not also act as the trigger for entry to the rewrite-pending state). 1: Triggers a simultaneous rewrite pending state. The simultaneous rewrite pending flag (TAUJnRSFm) is set to 1. The system waits for a simultaneous rewrite trigger. These bit settings are applied when TAUJnRDE.TAUJnRDEm = 1.

(4) TAUJnRSF - TAUJn channel reload status register

This register indicates the simultaneous rewrite status.

Access Readable in 8-bit units.

Address <TAUJn_base1> + 6C_H

Initial value 00_H

Any reset source triggers initialization.

7	6	5	4	3	2	1	0
-	-	-	-	TAUJnRSF 03	TAUJnRSF 02	TAUJnRSF 01	TAUJnRSF 00
R	R	R	R	R	R	R	R

Table 14-67 Description of TAUJnRSF Register

Bit Position	Bit Name	Function
3 to 0	TAUJnRSFm	Indicates the simultaneous rewrite status: 0: Indicates that simultaneous rewrite has been made due to occurrence of a simultaneous rewrite trigger 1: Indicates that TAUJ is in the simultaneous rewrite pending status (TAUJnRDTm = 1)

Section 15 TSG2 (TSG20)

15.1 Functions of TSG2n

Channels This product provides 1 instance of TSG2n.

Table 15-1 TSG2 Channels

TSG2	
Number of instance	1
Name	TSG20

Meaning of n Throughout this section, the TSG2 channels are identified by suffix n (n = 0). For example, n is used as in TSG2n control register (TSnCTL0).

Register addresses TSG2n register addresses are given as address offsets from the individual base address <TSG2n_base0> or <TSG2n_base1>. Table 15-2 shows the base addresses of TSG2n.

Table 15-2 TSG2 Register Base Addresses

TSG2n	<TSG2n_base0> Address	<TSG2n_base1> Address
TSG20	FF82 E000 _H	FFFF CC00 _H

Clock supply TSG2n is connected to PCLK and is supplied with the PCLK clock signal input.

Table 15-3 TSG2 Clock Supply

TSG2n	Supplied Clock	Connected to
TSG20	PCLK	Clock controller

I/O signals The I/O signals of the TSG2 are listed in Table 15-4.

Table 15-4 List of TSG2 I/O Signals

TSG2n Signal	Function	Connected to
TSG2nPTSI0 to TSG2nPTSI2	External pattern input	Port
TSG2nO0 to TSG2nO7	Timer output	Port
TSnOPCI0, TSnOPCI1	Trigger input signal	Internal signal (input)
TSnADTRG0, TSnADTRG1	A/D trigger signal	Internal signal (output)
TSnPTE	Pattern input change detection signal	Internal signal (output)
TSnPEC	Two phase encoder count signal	Internal signal (output)

Interrupt requests The TSG2 interrupt requests are listed in Table 15-5.

Table 15-5 List of TSG2 Interrupt Requests

TSG2n Interrupt Request	Function	Connected to
INTTSG2nI00	TSnCMP0 compare match interrupt	Interrupt controller
INTTSG2nI01	TSnCMP1 compare match interrupt	Interrupt controller
INTTSG2nI02	TSnCMP2 compare match interrupt	Interrupt controller
INTTSG2nI03	TSnCMP3 compare match interrupt	Interrupt controller
INTTSG2nI04	TSnCMP4 compare match interrupt	Interrupt controller
INTTSG2nI05	TSnCMP5 compare match interrupt	Interrupt controller
INTTSG2nI06	TSnCMP6 compare match interrupt	Interrupt controller
INTTSG2nI07	TSnCMP7 compare match interrupt	Interrupt controller
INTTSG2nI08	TSnCMP8 compare match interrupt	Interrupt controller
INTTSG2nI09	TSnCMP9 compare match interrupt	Interrupt controller
INTTSG2nI10	TSnCMP10 compare match interrupt	Interrupt controller
INTTSG2nI11	TSnCMP11 compare match interrupt	Interrupt controller DMA
INTTSG2nI12	TSnCMP12 compare match intererupt	Interrupt controller DMA
INTTSG2nIPEK	Peak interrupt	Interrupt controller DMA
INTTSG2nIVLY	Valley interrupt	Interrupt controller DMA
INTTSG2nIER	Error interrupt	Interrupt controller
INTTSG2nIWN	Warning interrupt	Interrupt controller

15.2 Functional Overview

The TSG2n is a 16-bit timer counter with various motor control functions.

- Count clock resolution: Minimum 12.5 ns (count clock = 80 MHz)
- Operating mode corresponding to various motor control methods
- Compare registers with reload buffer
- 10-bit dead time counter
 - Dead time counter with reload buffer
 - Independent dead time can be set for positive to inverse phase change and inverse to positive phase change.
- A/D conversion trigger signal generation
 - Three A/D conversion trigger signals can be generated by the compare registers TSnDCMP0W and TSnDCMP2.
 - Skipping function of A/D conversion trigger signals TSnADTRG0 and TSnADTRG1 can be set independently. The skipping ratio can be selected among 1/1, 1/2, 1/4, and 1/8.
 - The dedicated pin (TSG2nO7) can be used to output the toggle or diagnostic signal set by the TSnADTRG0 signal and reset by the TSnADTRG1 signal.
- Interrupt skipping
 - Skipping rate: 1/1 to 1/32
- Forced output stop function
 - Using the TOP function allows the high impedance control of the TSG2nO1 to TSG2nO6 pin output.
- Compare value setting
 - Reload (simultaneous rewrite) or anytime rewrite can be selected.
- Reload mode
 - Writing to TSnCMP1 (setting the reload request flag (TSnRSF)) enables reload, and allows simultaneous transfer of the values of multiple registers.
 - Data can be transferred at peak/valley/peak or valley reload timing*
 - Reload request flag (TSnRSF)
 - Register address assignment allowing DMA transfer
 - Reload skipping
- HT-PWM mode
 - 0 to 100% PWM duty cycle output is possible (with possible dead time reduction).
 - The LSB in the compare register can be used to append an additional pulse to the PWM output during count up, thus improving the output resolution without extra load on software.
- 120-DC control
 - Semi-automatic cruise function (trigger signal can be generated by an offset in conjunction with two-phase encoder, three-phase encoder, or ENCA).
- Three-phase encoder function (hall sensor signals can be input).
- Active level of the output pins (TSG2nO1 to TSG2nO6) can be set individually.
- Fail-safe function (warning interrupt or error interrupt can be generated)
 - Simultaneous active output detection function for positive and inverse phases.
 - Abnormal input detection function of the three-phase encoder

15.3 Configuration

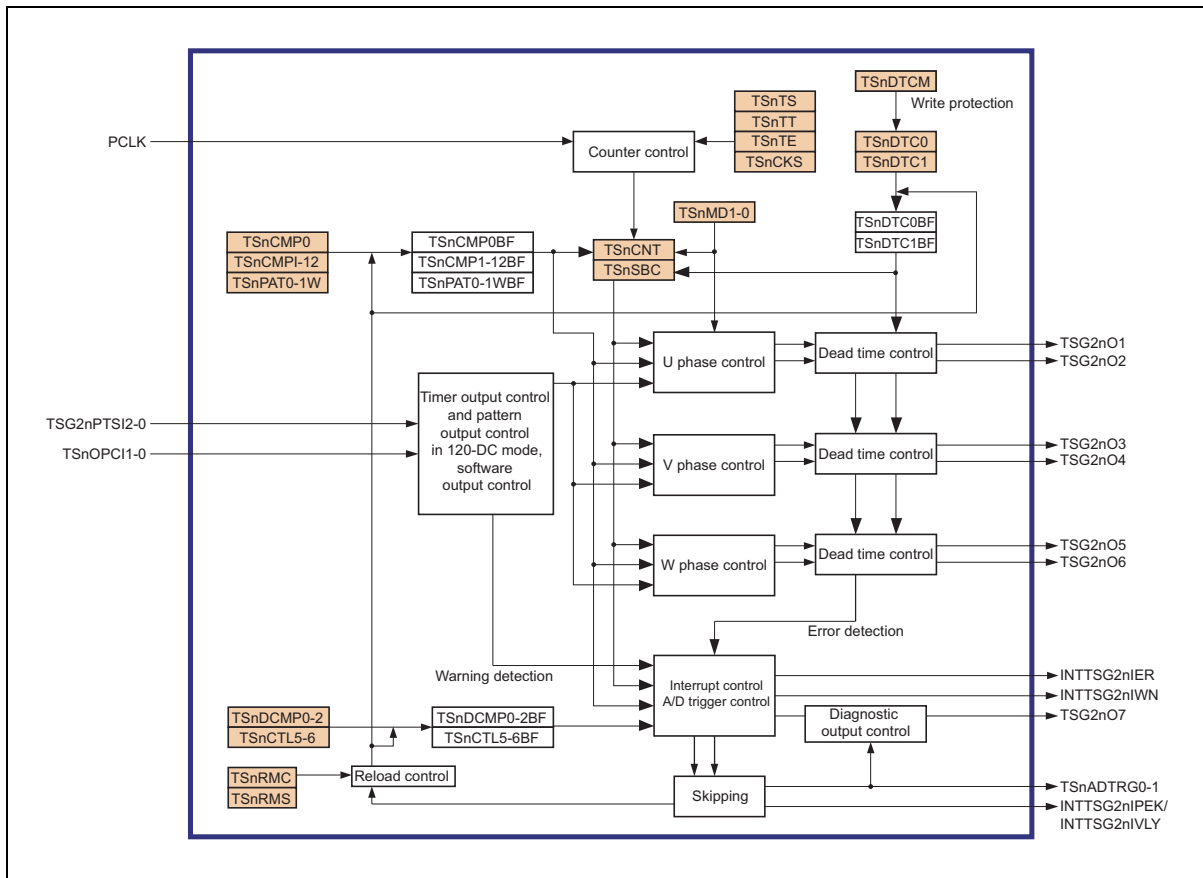

Figure 15-1 Block Diagram of TSG2n

15.4 Registers

This section contains a description of all registers of the TSG2n.

15.4.1 TSG2n Registers Overview

The TSG2n is controlled and operated based on the settings of the following registers listed in Table 15-6.

Table 15-6 TSG2n Registers (1/2)

Register Name	Symbol	Address
TSG2n control register 0	TSnCTL0	<TSG2n_base0> + 208 _H
TSG2n control register 1	TSnCTL1	<TSG2n_base0> + 20C _H
TSG2n control register 3	TSnCTL3	<TSG2n_base1> + 004 _H
TSG2n control register 4	TSnCTL4	<TSG2n_base1> + 07C _H
TSG2n control register 5	TSnCTL5	<TSG2n_base1> + 008 _H
TSG2n control register 6	TSnCTL6	<TSG2n_base1> + 00C _H
TSG2n I/O control register 0	TSnIOC0	<TSG2n_base0> + 200 _H
TSG2n I/O control register 1	TSnIOC1	<TSG2n_base0> + 204 _H
TSG2n I/O control register 2	TSnIOC2	<TSG2n_base1> + 000 _H
TSG2n I/O control register 3	TSnIOC3	<TSG2n_base1> + 074 _H
TSG2n status register 0	TSnSTR0	<TSG2n_base1> + 010 _H
TSG2n status register 1	TSnSTR1	<TSG2n_base1> + 014 _H
TSG2n status register 2	TSnSTR2	<TSG2n_base1> + 018 _H
TSG2n status clear trigger register	TSnSTC	<TSG2n_base1> + 01C _H
TSG2n option register 0	TSnOPT0	<TSG2n_base1> + 020 _H
TSG2n option register 1	TSnOPT1	<TSG2n_base1> + 024 _H
TSG2n trigger register 0	TSnTRG0	<TSG2n_base1> + 030 _H
TSG2n trigger register 1	TSnTRG1	<TSG2n_base1> + 034 _H
TSG2n counter read buffer register	TSnCNT	<TSG2n_base1> + 028 _H
TSG2n sub-counter read buffer register	TSnSBC	<TSG2n_base1> + 02C _H
TSG2n compare register 0	TSnCMP0	<TSG2n_base1> + 058 _H
TSG2n compare register 1, 2	TSnCMP1W	<TSG2n_base1> + 040 _H
TSG2n compare register 3, 4	TSnCMP3W	<TSG2n_base1> + 04C _H
TSG2n compare register 5, 6	TSnCMP5W	<TSG2n_base1> + 044 _H
TSG2n compare register 7, 8	TSnCMP7W	<TSG2n_base1> + 050 _H
TSG2n compare register 9, 10	TSnCMP9W	<TSG2n_base1> + 048 _H
TSG2n compare register 11, 12	TSnCMP11W	<TSG2n_base1> + 054 _H
TSG2n compare registers 1 to 12	TSnCMP1-12	<TSG2n_base1> + 080 _H - 0AC _H
TSG2n diagnostic output compare register 0 and 1	TSnDCMP0W	<TSG2n_base1> + 05C _H
TSG2n diagnostic output compare register 2	TSnDCMP2	<TSG2n_base1> + 060 _H

Table 15-6 TSG2n Registers (2/2)

Register Name	Symbol	Address
TSG2n pattern register 0	TSnPAT0W	<TSG2n_base1> + 064 _H
TSG2n pattern register 1	TSnPAT1W	<TSG2n_base1> + 068 _H
TSG2n dead time setting register 0	TSnDTC0W	<TSG2n_base1> + 06C _H
TSG2n dead time setting register 1	TSnDTC1W	<TSG2n_base1> + 070 _H
TSG2n HT-PWM U phase compare register	TSnCMPU	<TSG2n_base1> + 0B0 _H
TSG2n HT-PWM V phase compare register	TSnCMPV	<TSG2n_base1> + 0B4 _H
TSG2n HT-PWM W phase compare register	TSnCMPW	<TSG2n_base1> + 0B8 _H
TSG2n SP-PWM U phase active width setting register	TSnUPW	<TSG2n_base1> + 0BC _H
TSG2n SP-PWM V phase active width setting register	TSnVPW	<TSG2n_base1> + 0C0 _H
TSG2n SP-PWM W phase active width setting register	TSnWPW	<TSG2n_base1> + 0C4 _H
TSG2n dead time protection register	TSnDTPR	<TSG2n_base0> + 210 _H

15.4.2 TSG2n Register Details

(1) TSG2n Control Register 0 (TSnCTL0)

This register specifies the pulse width for the diagnostic output and operating mode of the TSG2n.

Access This register can be read/written in 8-bit units.

Address <TSG2n_base0> + 208_H

Initial value 00_H

This register is initialized by a reset from any source.

7	6	5	4	3	2	1	0
-	-	-	TSn DWD	-	-	TSnMD [1:0]	
R	R	R	R/W	R	R	R/W	R/W

Table 15-7 TSnCTL0 Register Contents

Bit Position	Bit Name	Function															
4	TSnDWD	Selects the pulse width for the diagnostic output. 0: The output pulse width is set to 8 clocks. 1: The output pulse width is set to 16 clocks. <ul style="list-style-type: none"> The setting of this bit is valid when diagnostic output is enabled (TSnIOC1.TSnTGS = 1). 															
1, 0	TSnMD[1:0]	Selects timer mode. <table border="1" style="margin-left: 20px;"> <thead> <tr> <th>TSnMD1</th> <th>TSnMD0</th> <th>Timer Mode</th> </tr> </thead> <tbody> <tr> <td>0</td> <td>0</td> <td>PWM mode</td> </tr> <tr> <td>0</td> <td>1</td> <td>HT-PWM mode (HT-PWM)</td> </tr> <tr> <td>1</td> <td>0</td> <td>Shift pulse PWM mode (SP-PWM)</td> </tr> <tr> <td>1</td> <td>1</td> <td>120-DC mode</td> </tr> </tbody> </table>	TSnMD1	TSnMD0	Timer Mode	0	0	PWM mode	0	1	HT-PWM mode (HT-PWM)	1	0	Shift pulse PWM mode (SP-PWM)	1	1	120-DC mode
TSnMD1	TSnMD0	Timer Mode															
0	0	PWM mode															
0	1	HT-PWM mode (HT-PWM)															
1	0	Shift pulse PWM mode (SP-PWM)															
1	1	120-DC mode															

Caution This register should be set when the timer is stopped (TSnSTR0.TSnTE = 0). Only the same value can be written during timer operation (TSnSTR0.TSnTE = 1). If the different value is written to this register when TSnSTR0.TSnTE = 1, timer operation cannot be guaranteed. If this register is erroneously rewritten, set this register again after stopping the timer.

(2) TSG2n Control Register 1 (TSnCTL1)

This register controls the flags of TSG2n.

Access This register can be read/written in 16-bit units.

Address <TSG2n_base0> + 20C_H

Initial value 0000_H

This register is initialized by a reset from any source.

15	14	13	12	11	10	9	8	7	6	5	4	3	2	1	0
-	-	-	-	-	-	TSn TBA2	TSn TBA1	TSn TBA0	TSn PPC	TSn PEC	TSn TDC	TSn NDC	TSn PRC	TSnPTC [1:0]	
R	R	R	R	R	R	R/W	R/W	R/W	R/W	R/W	R/W	R/W	R/W	R/W	R/W

Table 15-8 TSnCTL1 Register Contents (1/2)

Bit Position	Bit Name	Function
9	TSnTBA2	<p>Enables or disables detection of the simultaneous active states of the TSG2nO5 and TSG2nO6 pins.</p> <p>0: Disables detection of simultaneous active states of the TSG2nO5 and TSG2nO6 pins.</p> <p>1: Enables detection of simultaneous active states of the TSG2nO5 and TSG2nO6 pins.</p> <ul style="list-style-type: none"> If the simultaneous active state is detected when the TSnIOC1.TSnEOC bit and TSnTBA2 bit are 1, the positive phase and inverse phase simultaneous active detection flag 2 (TSnTBF2) is set to 1, and an error interrupt (INTTSG2nIER) is generated.
8	TSnTBA1	<p>Enables or disables detection of the simultaneous active states of the TSG2nO3 and TSG2nO4 pins.</p> <p>0: Disables detection of simultaneous active states of the TSG2nO3 and TSG2nO4 pins.</p> <p>1: Enables detection of simultaneous active states of the TSG2nO3 and TSG2nO4 pins.</p> <ul style="list-style-type: none"> If the simultaneous active state is detected when the TSnIOC1.TSnEOC bit and TSnTBA1 bit are 1, the positive phase and inverse phase simultaneous active detection flag 1 (TSnTBF1) is set to 1, and an error interrupt (INTTSG2nIER) is generated.
7	TSnTBA0	<p>Enables or disables detection of the simultaneous active states of the TSG2nO1 and TSG2nO2 pins.</p> <p>0: Disables detection of simultaneous active states of the TSG2nO1 and TSG2nO2 pins.</p> <p>1: Enables detection of simultaneous active states of the TSG2nO1 and TSG2nO2 pins.</p> <ul style="list-style-type: none"> If the simultaneous active state is detected when the TSnIOC1.TSnEOC bit and TSnTBA0 bit are 1, the positive phase and inverse phase simultaneous active detection flag 0 (TSnTBF0) is set to 1, and an error interrupt (INTTSG2nIER) is generated.
6	TSnPPC	<p>Enables or disables detection of the pattern phase difference (TSnSTR2.TSnPPF) between the TSG2nPTS12 to TSG2nPTS10 and TSnOPF2 to TSnOPF0.</p> <p>0: Disables detection of I/O pattern difference.</p> <p>1: Enables detection of I/O pattern difference.</p>

Caution If TSnDTC0 or TSnDTC1 is set to 0000_H (without dead time), the TSnTBA2 to TSnTBA0 bits should be set to 0. This register should be set when the timer is stopped (TSnSTR0.TSnTE = 0). Only the same value can be written during timer operation (TSnSTR0.TSnTE = 1). If the different value is written to this register when TSnSTR0.TSnTE = 1, timer operation cannot be guaranteed. If this register is erroneously rewritten, set this register again after stopping the timer.

Table 15-8 TSnCTL1 Register Contents (2/2)

Bit Position	Bit Name	Function														
5	TSnPEC	Enables or disables detection of the pattern error (TSnSTR2.TSnPEF) of the TSG2nPTS12 to TSG2nPTS10 pins. 0: Disables detection of the pattern error of the TSG2nPTS12 to TSG2nPTS10 pins. 1: Enables detection of the pattern error of the TSG2nPTS12 to TSG2nPTS10 pins.														
4	TSnTDC	Enables or disables detection of the simultaneous trigger (TSnSTR2.TSnTDF) of the TSnOPCI0 and TSnOPCI1 signals. 0: Disables detection of the simultaneous trigger of the TSnOPCI0 and TSnOPCI1 signals. 1: Enables detection of the simultaneous trigger of the TSnOPCI0 and TSnOPCI1 signals.														
3	TSnNDC	Enables or disables detection of the noise generation (two or more pins change simultaneously) (TSnSTR2.TSnNDF) on the TSG2nPTS12 to TSG2nPTS10 pins. 0: Disables detection of the noise generation on the TSG2nPTS12 to TSG2nPTS10 pins. 1: Enables detection of the noise generation on the TSG2nPTS12 to TSG2nPTS10 pins.														
2	TSnPRC	Enables or disables detection of the reversal of the pattern (TSnSTR2.TSnPRF) of the TSG2nPTS12 to TSG2nPTS10 pins. 0: Disables detection of the reversal of the pattern of the TSG2nPTS12 to TSG2nPTS10 pins. 1: Enables detection of the reversal of the pattern of the TSG2nPTS12 to TSG2nPTS10 pins.														
1, 0	TSnPTC[1:0]	Enables or disables detection of an abnormal toggle (TSnSTR2.TSnPTF) of the TSG2nPTS12 to TSG2nPTS10 pins between TSnOPCI1 and TSnOPCI0 triggers. <table border="1" data-bbox="571 1227 1385 1617"> <thead> <tr> <th>TSnPTC1</th> <th>TSnPTC0</th> <th>Function</th> </tr> </thead> <tbody> <tr> <td>0</td> <td>0</td> <td rowspan="2">Disables detection of an abnormal toggle of the TSG2nPTS12 to TSG2nPTS10 pins.</td> </tr> <tr> <td>0</td> <td>1</td> </tr> <tr> <td>1</td> <td>0</td> <td>Enables detection of an abnormal toggle of the TSG2nPTS12 to TSG2nPTS10 pins.</td> </tr> <tr> <td>1</td> <td>1</td> <td>Enables detection of an abnormal toggle of the TSG2nPTS12 to TSG2nPTS10 pins. When an abnormal toggle is detected, the pattern output trigger is automatically switched from pattern switch to trigger switch (TSnPOT is switched from 1 to 0).</td> </tr> </tbody> </table>	TSnPTC1	TSnPTC0	Function	0	0	Disables detection of an abnormal toggle of the TSG2nPTS12 to TSG2nPTS10 pins.	0	1	1	0	Enables detection of an abnormal toggle of the TSG2nPTS12 to TSG2nPTS10 pins.	1	1	Enables detection of an abnormal toggle of the TSG2nPTS12 to TSG2nPTS10 pins. When an abnormal toggle is detected, the pattern output trigger is automatically switched from pattern switch to trigger switch (TSnPOT is switched from 1 to 0).
TSnPTC1	TSnPTC0	Function														
0	0	Disables detection of an abnormal toggle of the TSG2nPTS12 to TSG2nPTS10 pins.														
0	1															
1	0	Enables detection of an abnormal toggle of the TSG2nPTS12 to TSG2nPTS10 pins.														
1	1	Enables detection of an abnormal toggle of the TSG2nPTS12 to TSG2nPTS10 pins. When an abnormal toggle is detected, the pattern output trigger is automatically switched from pattern switch to trigger switch (TSnPOT is switched from 1 to 0).														

Caution This register should be set when the timer is stopped (TSnSTR0.TSnTE = 0). Only the same value can be written during timer operation (TSnSTR0.TSnTE = 1). If the different value is written to this register when TSnSTR0.TSnTE = 1, timer operation cannot be guaranteed. If this register is erroneously rewritten, set this register again after stopping the timer.

(3) TSG2n Control Register 3 (TSnCTL3)

This register selects the rewrite method of the compare registers.

Access This register can be read/written in 8-bit units.

Address <TSG2n_base1> + 004_H

Initial value 00_H

This register is initialized by a reset from any source.

7	6	5	4	3	2	1	0
-	-	-	-	-	-	TSn RIA	TSn RMC
R	R	R	R	R	R	R/W	R/W

Table 15-9 TSnCTL3 Register Contents

Bit Position	Bit Name	Function
1	TSnRIA	Selects the reload timing of the compare register values. 0: The reload timing is set to peak reload timing (set by TSnCTL4.TSnPRE) and valley reload timing (set by TSnCTL4.TSnVRE). 1: The reload timing is set to peak interrupt timing and valley interrupt timing. <ul style="list-style-type: none"> The setting of this bit is valid in reload mode (TSnRMC = 0).
0	TSnRMC	Selects the transfer timing of the compare register values. 0: Reload mode (simultaneous rewrite) Writing to TSnCMP1 (TSnCMP1W, TSnCMPU, TSnUPW) enables reloading and the register values are rewritten simultaneously at the next reload timing. Writing to any register other than TSnCMP1 (TSnCMP1W, TSnCMPU, TSnUPW) does not enable reloading. 1: Anytime rewrite mode The compare registers are rewritten independently. Whenever a value is written to the compare register, the written value is reflected immediately. TSnRSF is cleared.

(4) TSG2n Control Register 4 (TSnCTL4)

This register enables or disables generation of a peak interrupt and a valley interrupt, and the reload timing.

Access This register can be read/written in 32-bit units.

Address <TSG2n_base1> + 07C_H

Initial value 00000000_H

This register is initialized by a reset from any source.

31	30	29	28	27	26	25	24	23	22	21	20	19	18	17	16
-	-	-	-	-	-	-	-	-	-	-	-	-	-	-	-
R	R	R	R	R	R	R	R	R	R	R	R	R	R	R	R
15	14	13	12	11	10	9	8	7	6	5	4	3	2	1	0
-	-	-	-	-	-	-	TSn PRE	TSn VRE	TSn PIE	TSn VIE	TSnRCC[04:00]				
R	R	R	R	R	R	R	R/W	R/W	R/W	R/W	R/W	R/W	R/W	R/W	R/W

Table 15-10 TSnCTL4 Register Contents (1/2)

Bit Position	Bit Name	Function
8	TSnPRE	Enables or disables the peak reload timing. 0: Disables reload operation at the peak timing of the 16-bit counter. 1: Enables reload operation at the peak timing of the 16-bit counter. <ul style="list-style-type: none"> The peak reload timing means the peak timing of the 16-bit counter in HT-PWM mode and the clear timing of the 16-bit counter by compare match in any mode other than HT-PWM mode. When the reload operation at the peak timing of the 16-bit counter is disabled (TSnPRE = 0), reload is not executed in any mode other than HT-PWM mode.
7	TSnVRE	Enables or disables the valley reload timing. 0: Disables reload operation at the valley timing of the 16-bit counter. 1: Enables reload operation at the valley timing of the 16-bit counter. <ul style="list-style-type: none"> The setting of this bit is valid only in HT-PWM mode.
6	TSnPIE	Enables or disables generation of a peak interrupt (INTTSG2nIPEK). 0: Disables generation of a peak interrupt (INTTSG2nIPEK) at the peak timing of the 16-bit counter. Interrupts are not skipped. 1: Enables generation of a peak interrupt (INTTSG2nIPEK) at the peak timing of the 16-bit counter. Interrupts are skipped.
5	TSnVIE	Enables or disables generation of a valley interrupt (INTTSG2nIVLY). 0: Disables generation of a valley interrupt (INTTSG2nIVLY) at the valley timing of the 16-bit counter. Interrupts are not skipped. 1: Enables generation of a valley interrupt (INTTSG2nIVLY) at the valley timing of the 16-bit counter. Interrupts are skipped. <ul style="list-style-type: none"> The setting of this bit is valid only in HT-PWM mode.

Table 15-10 TSnCTL4 Register Contents (2/2)

Bit Position	Bit Name	Function																																																						
4 to 0	TSnRCC [04:00]	<p>Specifies the skipping rate of the interrupts (INTTSG2nIPEK and INTTSG2nIVLY) and reload.</p> <table border="1"> <thead> <tr> <th>TSnRCC04</th> <th>TSnRCC03</th> <th>TSnRCC02</th> <th>TSnRCC01</th> <th>TSnRCC00</th> <th>Skipping Rate</th> </tr> </thead> <tbody> <tr> <td>0</td> <td>0</td> <td>0</td> <td>0</td> <td>0</td> <td>None</td> </tr> <tr> <td>0</td> <td>0</td> <td>0</td> <td>0</td> <td>1</td> <td>1/2</td> </tr> <tr> <td>0</td> <td>0</td> <td>0</td> <td>1</td> <td>0</td> <td>1/3</td> </tr> <tr> <td>0</td> <td>0</td> <td>0</td> <td>1</td> <td>1</td> <td>1/4</td> </tr> <tr> <td>⋮</td> <td>⋮</td> <td>⋮</td> <td>⋮</td> <td>⋮</td> <td>⋮</td> </tr> <tr> <td>1</td> <td>1</td> <td>1</td> <td>0</td> <td>1</td> <td>1/30</td> </tr> <tr> <td>1</td> <td>1</td> <td>1</td> <td>1</td> <td>0</td> <td>1/31</td> </tr> <tr> <td>1</td> <td>1</td> <td>1</td> <td>1</td> <td>1</td> <td>1/32</td> </tr> </tbody> </table> <ul style="list-style-type: none"> When a write access is made (including a write of the same value to TSnRCC04 to TSnRCC00) to TSnCTL4 during timer operation (TSnSTR0.TSnTE = 1), the interrupt skipping counter is cleared. 	TSnRCC04	TSnRCC03	TSnRCC02	TSnRCC01	TSnRCC00	Skipping Rate	0	0	0	0	0	None	0	0	0	0	1	1/2	0	0	0	1	0	1/3	0	0	0	1	1	1/4	⋮	⋮	⋮	⋮	⋮	⋮	1	1	1	0	1	1/30	1	1	1	1	0	1/31	1	1	1	1	1	1/32
TSnRCC04	TSnRCC03	TSnRCC02	TSnRCC01	TSnRCC00	Skipping Rate																																																			
0	0	0	0	0	None																																																			
0	0	0	0	1	1/2																																																			
0	0	0	1	0	1/3																																																			
0	0	0	1	1	1/4																																																			
⋮	⋮	⋮	⋮	⋮	⋮																																																			
1	1	1	0	1	1/30																																																			
1	1	1	1	0	1/31																																																			
1	1	1	1	1	1/32																																																			

(5) TSG2n Control Register 5 (TSnCTL5)

This register controls A/D conversion trigger output (TSnADTRG0).

Access This register can be read/written in 16-bit units.

Address <TSG2n_base1> + 008_H

Initial value 0000_H

This register is initialized by a reset from any source.

15	14	13	12	11	10	9	8	7	6	5	4	3	2	1	0
-	-	-	-	TSnACC [01:00]	TSn AT09	TSn AT08	TSn AT07	TSn AT06	TSn AT05	TSn AT04	TSn AT03	TSn AT02	TSn AT01	TSn AT00	
R	R	R	R	R/W	R/W	R/W	R/W	R/W	R/W	R/W	R/W	R/W	R/W	R/W	R/W

Table 15-11 TSnCTL5 Register Contents (1/3)

Bit Position	Bit Name	Function															
11, 10	TSnACC [01:00]	<p>Specifies the skipping rate of the A/D conversion trigger (TSnADTRG0).</p> <table border="1"> <thead> <tr> <th>TSnACC01</th><th>TSnACC00</th><th>Skipping Rate</th></tr> </thead> <tbody> <tr> <td>0</td><td>0</td><td>None</td></tr> <tr> <td>0</td><td>1</td><td>1/2</td></tr> <tr> <td>1</td><td>0</td><td>1/4</td></tr> <tr> <td>1</td><td>1</td><td>1/8</td></tr> </tbody> </table> <ul style="list-style-type: none"> When a write access is made (including a write of the same value to TSnACC01 and TSnACC00) to TSnCTL5 during timer operation (TSnSTR0.TSnTE = 1), the interrupt skipping counter is cleared. 	TSnACC01	TSnACC00	Skipping Rate	0	0	None	0	1	1/2	1	0	1/4	1	1	1/8
TSnACC01	TSnACC00	Skipping Rate															
0	0	None															
0	1	1/2															
1	0	1/4															
1	1	1/8															
9	TSnAT09	<p>Specifies generation of A/D conversion trigger (TSnADTRG0) at the (peak) timing when the 16-bit sub-counter switches from incrementing to decrementing.</p> <p>0: Disables generation of the A/D conversion trigger at the peak timing of the 16-bit sub-counter. 1: Enables generation of the A/D conversion trigger at the peak timing of the 16-bit sub-counter.</p> <ul style="list-style-type: none"> The TSnAT09 bit can be set to 1 only in HT-PWM mode. In other modes, the TSnAT09 bit should be set to 0. Do not set the TSnAT09 bit to 1 when TSnDTC0W is not 0000_H and TSnDTC1W is 0000_H. A/D conversion trigger is not generated at the peak timing of the 16-bit sub-counter even if set so. 															
8	TSnAT08	<p>Specifies generation of A/D conversion trigger (TSnADTRG0) at the (valley) timing when the 16-bit sub-counter switches from decrementing to incrementing.</p> <p>0: Disables generation of the A/D conversion trigger at the valley timing of the 16-bit sub-counter. 1: Enables generation of the A/D conversion trigger at the valley timing of the 16-bit sub-counter.</p> <ul style="list-style-type: none"> The TSnAT08 bit can be set to 1 only in HT-PWM mode. In other modes, the TSnAT08 bit should be set to 0. Do not set the TSnAT08 bit to 1 when TSnDTC0W is 0000_H and TSnDTC1W is not 0000_H. A/D conversion trigger is not generated at the valley timing of the 16-bit sub-counter even if set so. 															

Table 15-11 TSnCTL5 Register Contents (2/3)

Bit Position	Bit Name	Function
7	TSnAT07	<p>Specifies generation of A/D conversion trigger (TSnADTRG0) at the match timing of the 16-bit counter value during defragmentation with the TSnDCMP2 value.</p> <p>0: Disables generation of the A/D conversion trigger at the match timing of the 16-bit counter value during defragmentation with the TSnDCMP2 value. 1: Enables generation of the A/D conversion trigger at the match timing of the 16-bit counter value during defragmentation with the TSnDCMP2 value.</p> <ul style="list-style-type: none"> This bit can be set to 1 only in HT-PWM mode. In other modes, this bit should be set to 0.
6	TSnAT06	<p>Specifies generation of A/D conversion trigger (TSnADTRG0) at the match timing of the 16-bit counter value during incrementation with the TSnDCMP2 value.</p> <p>0: Disables generation of the A/D conversion trigger at the match timing of the 16-bit counter value during incrementation with the TSnDCMP2 value. 1: Enables generation of the A/D conversion trigger at the match timing of the 16-bit counter value during incrementation with the TSnDCMP2 value.</p>
5	TSnAT05	<p>Specifies generation of A/D conversion trigger (TSnADTRG0) at the match timing of the 16-bit counter value during defragmentation with the TSnDCMP1 value.</p> <p>0: Disables generation of the A/D conversion trigger at the match timing of the 16-bit counter value during defragmentation with the TSnDCMP1 value. 1: Enables generation of the A/D conversion trigger at the match timing of the 16-bit counter value during defragmentation with the TSnDCMP1 value.</p> <ul style="list-style-type: none"> This bit can be set to 1 only in HT-PWM mode. In other modes, this bit should be set to 0.
4	TSnAT04	<p>Specifies generation of A/D conversion trigger (TSnADTRG0) at the match timing of the 16-bit counter value during incrementation with the TSnDCMP1 value.</p> <p>0: Disables generation of the A/D conversion trigger at the match timing of the 16-bit counter value during incrementation with the TSnDCMP1. 1: Enables generation of the A/D conversion trigger at the match timing of the 16-bit counter value during incrementation with the TSnDCMP1 value.</p>
3	TSnAT03	<p>Specifies generation of A/D conversion trigger (TSnADTRG0) at the match timing of the 16-bit counter value during defragmentation with the TSnDCMP0 value.</p> <p>0: Disables generation of the A/D conversion trigger at the match timing of the 16-bit counter value during defragmentation with the TSnDCMP0 value. 1: Enables generation of the A/D conversion trigger at the match timing of the 16-bit counter value during defragmentation with the TSnDCMP0 value.</p> <ul style="list-style-type: none"> This bit can be set to 1 only in HT-PWM mode. In other modes, this bit should be set to 0.
2	TSnAT02	<p>Specifies generation of A/D conversion trigger (TSnADTRG0) at the match timing of the 16-bit counter value during incrementation with the TSnDCMP0 value.</p> <p>0: Disables generation of the A/D conversion trigger at the match timing of the 16-bit counter value during incrementation with the TSnDCMP0 value. 1: Enables generation of the A/D conversion trigger at the timing of the 16-bit counter value during incrementation with the TSnDCMP0.</p>
1	TSnAT01	<p>Specifies generation of A/D conversion trigger (TSnADTRG0) at the timing (peak interrupt) when the 16-bit counter switches from incrementing to decrementing.</p> <p>0: Disables generation of the A/D conversion trigger at the timing of a peak interrupt (INTTSG2nIPEK) after being skipped. 1: Enables generation of the A/D conversion trigger at the timing of a peak interrupt (INTTSG2nIPEK) after being skipped.</p>

Table 15-11 TSnCTL5 Register Contents (3/3)

Bit Position	Bit Name	Function
0	TSnAT00	<p>Specifies generation of A/D conversion trigger (TSnADTRG0) at the timing (valley interrupt) when the 16-bit counter switches from decrementing to incrementing.</p> <p>0: Disables generation of the A/D conversion trigger at the timing of a valley interrupt (INTTSG2nIVLY) after being skipped.</p> <p>1: Enables generation of the A/D conversion trigger at the timing of a valley interrupt (INTTSG2nIVLY) after being skipped.</p> <ul style="list-style-type: none">• This bit can be set to 1 only in HT-PWM mode. In other modes, this bit should be set to 0.

(6) TSG2n Control Register 6 (TSnCTL6)

This register controls the A/D conversion trigger output (TSnADTRG1).

Access This register can be read/written in 16-bit units.

Address <TSG2n_base1> + 00C_H

Initial value 0000_H

This register is initialized by a reset from any source.

15	14	13	12	11	10	9	8	7	6	5	4	3	2	1	0
-	-	-	-	TSnACC [11:10]	TSn AT19	TSn AT18	TSn AT17	TSn AT16	TSn AT15	TSn AT14	TSn AT13	TSn AT12	TSn AT11	TSn AT10	
R	R	R	R	R/W	R/W	R/W	R/W	R/W	R/W	R/W	R/W	R/W	R/W	R/W	R/W

Table 15-12 TSnCTL6 Register Contents (1/2)

Bit Position	Bit Name	Function															
11, 10	TSnACC [11:10]	<p>Specifies the skipping rate of the A/D conversion trigger (TSnADTRG1).</p> <table border="1"> <thead> <tr> <th>TSnACC11</th><th>TSnACC10</th><th>Skipping Rate</th></tr> </thead> <tbody> <tr> <td>0</td><td>0</td><td>None</td></tr> <tr> <td>0</td><td>1</td><td>1/2</td></tr> <tr> <td>1</td><td>0</td><td>1/4</td></tr> <tr> <td>1</td><td>1</td><td>1/8</td></tr> </tbody> </table> <ul style="list-style-type: none"> When a write access is made (including a write of the same value to TSnACC11 and TSnACC10) to TSnCTL6 during timer operation (TSnSTR0.TSnTE = 1), the skipping counter is cleared. 	TSnACC11	TSnACC10	Skipping Rate	0	0	None	0	1	1/2	1	0	1/4	1	1	1/8
TSnACC11	TSnACC10	Skipping Rate															
0	0	None															
0	1	1/2															
1	0	1/4															
1	1	1/8															
9	TSnAT19	<p>Specifies generation of A/D conversion trigger (TSnADTRG1) at the (peak) timing when the 16-bit sub-counter switches from incrementing to decrementing.</p> <p>0: Disables generation of the A/D conversion trigger at the peak timing of the 16-bit sub-counter.</p> <p>1: Enables generation of the A/D conversion trigger at the peak timing of the 16-bit sub-counter.</p> <ul style="list-style-type: none"> The TSnAT19 bit can be set to 1 only in HT-PWM mode. In other modes, the TSnAT19 bit should be set to 0. Do not set the TSnAT19 bit to 1 when TSnDTC0W is not 0000_H and TSnDTC1W is 0000_H. A/D conversion trigger is not generated at the peak timing of the 16-bit sub-counter even if set so. 															
8	TSnAT18	<p>Specifies generation of A/D conversion trigger (TSnADTRG1) at the (valley) timing when the 16-bit sub-counter switches from decrementing to incrementing.</p> <p>0: Disables generation of the A/D conversion trigger at the valley timing of the 16-bit sub-counter.</p> <p>1: Enables generation of the A/D conversion trigger at the valley timing of the 16-bit sub-counter.</p> <ul style="list-style-type: none"> The TSnAT18 bit can be set to 1 only in HT-PWM mode. In other modes, the TSnAT18 bit should be set to 0. Do not set the TSnAT18 bit to 1 when TSnDTC0W is 0000_H and TSnDTC1W is not 0000_H. A/D conversion trigger is not generated at the valley timing of the 16-bit sub-counter even if set so. 															

Table 15-12 TSnCTL6 Register Contents (2/2)

Bit Position	Bit Name	Function
7	TSnAT17	Specifies generation of A/D conversion trigger (TSnADTRG1) at the match timing of the 16-bit counter value during defragmentation and the TSnDCMP2 value. 0: Disables generation of the A/D conversion trigger at the match timing of the 16-bit counter value during defragmentation with the TSnDCMP2 value. 1: Enables generation of the A/D conversion trigger at the match timing of the 16-bit counter value during defragmentation with the TSnDCMP2 value. • This bit can be set to 1 only in HT-PWM mode. In other modes, this bit should be set to 0.
6	TSnAT16	Specifies generation of A/D conversion trigger (TSnADTRG1) at the match timing of the 16-bit counter value during incrementation with the TSnDCMP2 value. 0: Disables generation of the A/D conversion trigger at the match timing of the 16-bit counter value during incrementation with the TSnDCMP2 value. 1: Enables generation of the A/D conversion trigger at the match timing of the 16-bit counter value during incrementation with the TSnDCMP2 value.
5	TSnAT15	Specifies generation of A/D conversion trigger (TSnADTRG1) at the match timing of the 16-bit counter value during defragmentation with the TSnDCMP1 value. 0: Disables generation of the A/D conversion trigger at the match timing of the 16-bit counter value during defragmentation with the TSnDCMP1 value. 1: Enables generation of the A/D conversion trigger at the match timing of the 16-bit counter value during defragmentation with the TSnDCMP1 value. • This bit can be set to 1 only in HT-PWM mode. In other modes, this bit should be set to 0.
4	TSnAT14	Specifies generation of A/D conversion trigger (TSnADTRG1) at the match timing of the 16-bit counter value during incrementation with the TSnDCMP1 value. 0: Disables generation of the A/D conversion trigger at the match timing of the 16-bit counter value during incrementation with the TSnDCMP1 value. 1: Enables generation of the A/D conversion trigger at the match timing of the 16-bit counter value during incrementation with the TSnDCMP1 value.
3	TSnAT13	Specifies generation of A/D conversion trigger (TSnADTRG1) at the match timing of the 16-bit counter value during defragmentation with the TSnDCMP0 value. 0: Disables generation of the A/D conversion trigger at the match timing of the 16-bit counter value during defragmentation with the TSnDCMP0 value. 1: Enables generation of the A/D conversion trigger at the match timing of the 16-bit counter value during defragmentation with the TSnDCMP0 value. • This bit can be set to 1 only in HT-PWM mode. In other modes, this bit should be set to 0.
2	TSnAT12	Specifies generation of A/D conversion trigger (TSnADTRG1) at the match timing of the 16-bit counter value during incrementation with the TSnDCMP0. 0: Disables generation of the A/D conversion trigger at the match timing of the 16-bit counter value during incrementation with the TSnDCMP0 value. 1: Enables generation of the A/D conversion trigger at the match timing of the 16-bit counter value during incrementation with the TSnDCMP0 value.
1	TSnAT11	Specifies generation of A/D conversion trigger (TSnADTRG1) at the timing (peak interrupt) when the 16-bit counter switches from incrementing to decrementing. 0: Disables generation of the A/D conversion trigger at the timing of a peak interrupt (INTTSG2nIPEK) after being skipped. 1: Enables generation of the A/D conversion trigger at the timing of a peak interrupt (INTTSG2nIPEK) after being skipped.
0	TSnAT10	Specifies generation of A/D conversion trigger (TSnADTRG1) at the timing (valley interrupt) when the 16-bit counter switches from decrementing to incrementing. 0: Disables generation of the A/D conversion trigger at the timing of a valley interrupt (INTTSG2nIVLY) after being skipped. 1: Enables generation of the A/D conversion trigger at the timing of a valley interrupt (INTTSG2nIVLY) after being skipped. • This bit can be set to 1 only in HT-PWM mode. In other modes, this bit should be set to 0.

(7) TSG2n I/O Control Register 0 (TSnIOC0)

This register controls the timer output pins (TSG2nO1 to TSG2nO6).

Access This register can be read/written in 8-bit units.

Address <TSG2n_base0> + 200_H

Initial value 7E_H

This register is initialized by a reset from any source.

7	6	5	4	3	2	1	0
-	TSn TOE6	TSn TOE5	TSn TOE4	TSn TOE3	TSn TOE2	TSn TOE1	-
R	R/W	R/W	R/W	R/W	R/W	R/W	R

Table 15-13 TSnIOC0 Register Contents

Bit Position	Bit Name	Function
6 to 1	TSnTOE6 to TSnTOE1	Enables or disables writing to TSnIOC2. 0: Enables control of TSG2nO6 to TSG2nO1 by rewriting TSnIOC2. 1: Disables control of TSG2nO6 to TSG2nO1 by rewriting TSnIOC2 (rewriting TSnIOC2 is ignored).

Caution This register should be set when the timer is stopped (TSnSTR0.TSnTE = 0). Only the same value can be written during timer operation (TSnSTR0.TSnTE = 1). If the different value is written to this register when TSnSTR0.TSnTE = 1, timer operation cannot be guaranteed. If this register is erroneously rewritten, set this register again after stopping the timer.

(8) TSG2n I/O Control Register 1 (TSnIOC1)

This register controls the timer output pins (TSG2nO1 to TSG2nO6).

Access This register can be read/written in 8-bit units.

Address <TSG2n_base0> + 204_H

Initial value 00_H

This register is initialized by a reset from any source.

7	6	5	4	3	2	1	0
-	-	-	TSn PTS	TSn EOC	TSn WOC	TSn TGS	TSn TOS
R	R	R	R/W	R/W	R/W	R/W	R/W

Table 15-14 TSnIOC1 Register Contents (1/2)

Bit Position	Bit Name	Function
4	TSnPTS	Enables or disables output of the edge detection signal (TSnPTE) of TSG2nPTSIO to TSG2nPTSIO2 and two-phase encoder count signal (TSnPEC). 0: Disables output of the toggle signal by edge detection of TSG2nPTSIO to TSG2nPTSIO2. 1: Enables output of the toggle signal by edge detection of TSG2nPTSIO to TSG2nPTSIO2. <ul style="list-style-type: none"> When TSnPTS is changed from 1 to 0, the levels of the TSnPTE and TSnPEC remain unchanged.
3	TSnEOC	Enables or disables detection of the error condition at the motor control. 0: Disables generation of an error interrupt (INTTSG2nIER). 1: Enables generation of an error interrupt (INTTSG2nIER). <ul style="list-style-type: none"> For details on controlling the error interrupt, see Section 15.10.1, Error Interrupt Function.
2	TSnWOC	Enables or disables detection of the warning condition at the motor control. 0: Disables generation of a warning interrupt (INTTSG2nIWN). 1: Enables generation of a warning interrupt (INTTSG2nIWN). <ul style="list-style-type: none"> For details on the controlling generation of warning interrupt, see Section 15.10.2, Warning Interrupt Function.

Caution This register should be set when the timer is stopped (TSnSTR0.TSnTE = 0). Only the same value can be written during timer operation (TSnSTR0.TSnTE = 1). If the different value is written to this register when TSnSTR0.TSnTE = 1, timer operation cannot be guaranteed. If this register is erroneously rewritten, set this register again after stopping the timer.

Table 15-14 TSnIOC1 Register Contents (2/2)

Bit Position	Bit Name	Function
1	TSnTGS	Selects the A/D conversion trigger diagnostic output (TSG2nO7) signal. 0: Selects A/D conversion trigger output. 1: Selects diagnostic output.
0	TSnTOS	Selects the timer counter increment/decrement status output (TSG2nO0) signal. 0: Outputs the up/down count flag of the 16-bit counter. 1: Outputs the up/down count flag of the 16-bit sub-counter. <ul style="list-style-type: none"> When TSnTOS is 0, the status of TSnSTR0.TSnCUF is output to TSG2nO0. When TSnTOS is 1, the status of TSnSTR0.TSnSUF is output to TSG2nO0. The setting of this bit is valid only in HT-PWM mode.

Caution This register should be set when the timer is stopped (TSnSTR0.TSnTE = 0). Only the same value can be written during timer operation (TSnSTR0.TSnTE = 1). If the different value is written to this register when TSnSTR0.TSnTE = 1, timer operation cannot be guaranteed. If this register is erroneously rewritten, set this register again after stopping the timer.

(9) TSG2n I/O Control Register 2 (TSnIOC2)

This register controls the timer output pins (TSG2nO1 to TSG2nO6).

Access This register can be read/written in 16-bit units.

Address <TSG2n_base1> + 000_H

Initial value 0000_H

This register is initialized by a reset from any source.

15	14	13	12	11	10	9	8	7	6	5	4	3	2	1	0
-	TSn OL6	TSn OL5	TSn OL4	TSn OL3	TSn OL2	TSn OL1	-	-	TSn TO6	TSn TO5	TSn TO4	TSn TO3	TSn TO2	TSn TO1	-
R	R/W	R/W	R/W	R/W	R/W	R/W	R	R	R/W	R/W	R/W	R/W	R/W	R/W	R

Table 15-15 TSnIOC2 Register Contents

Bit Position	Bit Name	Function
14 to 9	TSnOL6 to TSnOL1	Specifies the active level of TSG2nO6 to TSG2nO1 outputs. 0: High 1: Low
6 to 1	TSnTO6 to TSnTO1	Specifies the latch level of the output buffer of the TSG2nO6 to TSG2nO1. 0: Low 1: High

Caution When the counting is stopped (TSnTE = 0), the TSG2nO1 to TSG2nO6 pins maintain their previous output states. The output level should be changed by setting the TSnIOC0.TSnTOEm bit to 0, using the TSnTOm bit. This register can be rewritten when TSnIOC0.TSnTOEm = 0 (m = 1 to 6).

Note When TSG2nOm control is enabled (TSnIOC0.TSnTOEm = 0) by writing a new value to TSnIOC2 while the timer is stopped (TSnSTR0.TSnTE = 0), a desired level can be output on TSG2nOm by setting TSnOLm and TSnTOm in TSnIOC2.

TSnOLm	TSnTOm	Level output on TSG2nOm
0	0	Low
0	1	High
1	0	High
1	1	Low

(10) TSG2n I/O Control Register 3 (TSnIOC3)

This register controls timer output pins (TSG2nO1 to TSG2nO6).

Access This register can be read/written in 32-bit units.

Address <TSG2n_base1> + 074_H

Initial value 00000000_H

This register is initialized by a reset from any source.

31	30	29	28	27	26	25	24	23	22	21	20	19	18	17	16
-	-	-	-	-	-	-	-	-	-	-	-	-	-	-	-
R	R	R	R	R	R	R	R	R	R	R	R	R	R	R	R
15	14	13	12	11	10	9	8	7	6	5	4	3	2	1	0
-	-	-	-	-	-	-	-	-	TSn TOL6	TSn TOL5	TSn TOL4	TSn TOL3	TSn TOL2	TSn TOL1	-
R	R	R	R	R	R	R	R	R	R/W	R/W	R/W	R/W	R/W	R/W	R

Table 15-16 TSnIOC3 Register Contents

Bit Position	Bit Name	Function
6 to 1	TSnTOL6 to TSnTOL1	Controls the set/clear level of output. 0: Outputs the normal level. 1: Outputs the reversed level. • Setting of this bit is reflected at the start of output. The change of the output level is reflected at the next compare match timing after the change.

Caution TSnTOL6 to TSnTOL1 should be set to 0 in HT-PWM mode.

(11) TSG2n Status Register 0 (TSnSTR0)

This register controls the flags.

Access This register can be read/written in 8-bit units.

Address <TSG2n_base1> + 010_H

Initial value 00_H

This register is initialized by a reset from any source.

7	6	5	4	3	2	1	0
-	-	-	-	TSn CUF	TSn SUF	TSn RSF	TSn TE
R	R	R	R	R	R	R	R

Table 15-17 TSnSTR0 Register Contents

Bit Position	Bit Name	Function
3	TSnCUF	Indicates the count direction of the 16-bit counter. 0: The 16-bit counter is incremented. 1: The 16-bit counter is decremented. <ul style="list-style-type: none"> TSnCUF is valid only in HT-PWM mode. In other modes, it is invalid (TSnCUF = 0).
2	TSnSUF	Indicates the count direction of the 16-bit sub-counter. 0: The 16-bit sub-counter is incremented. 1: The 16-bit sub-counter is decremented. <ul style="list-style-type: none"> TSnSUF detects counting of the 16-bit sub-counter from 0000_H to (TSnCMP0 value - 0002_H) as up-counting, and counting from the TSnCMP0 value to 0002_H as down-counting. This bit is valid only in HT-PWM mode.
1	TSnRSF	Indicates whether there is a reload request. 0: No reload request or reload has completed. 1: There is a reload request. <ul style="list-style-type: none"> This bit is valid only in TSnRMC = 0. This bit indicates that the data to be transferred next is held. This bit is set to 1 by writing to TSnCMP1 (TSnCMP1W, TSnCMPU, TSnUPW), and cleared to 0 when reload has completed. When TSnRMC is changed from 0 to 1 in HT-PWM mode, TSnRSF is cleared to 0.
0	TSnTE	Indicates the TSG2n operation status. 0: TSG2n is stopped. 1: TSG2n is operating. <ul style="list-style-type: none"> This bit is set when TSnTRG0.TSnTS = 1, and cleared when TSnTRG1.TSnTT = 1.

(12) TSG2n Status Register 1 (TSnSTR1)

This register controls the flags.

Access This register can only be read in 8-bit units.

Address <TSG2n_base1> + 014_H

Initial value 00_H

This register is initialized by a reset from any source.

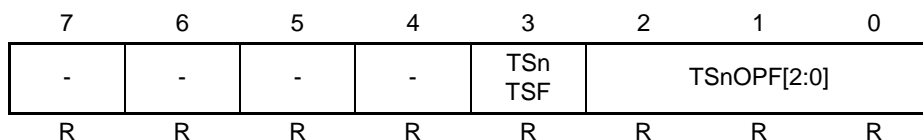
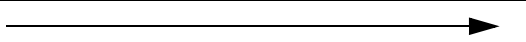
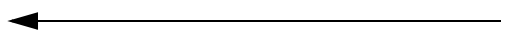
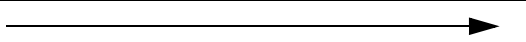
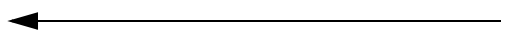
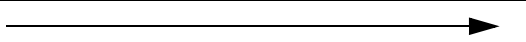
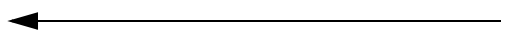

Table 15-18 TSnSTR1 Register Contents

Bit Position	Bit Name	Function						
3	TSnTSF	<p>Indicates the pattern change order of TSG2nPTSI0 to TSG2nPTSI2.</p> <p>0: Indicates that patterns are input to TSG2nPTSI0 to TSG2nPTSI2 in the normal rotation pattern order</p> <p>1: Indicates that patterns are input to TSG2nPTSI0 to TSG2nPTSI2 in the reverse rotation pattern order.</p> <table border="1" style="width: 100%; margin-top: 10px;"> <tr> <td style="padding: 2px;">Normal Rotation</td> <td style="text-align: center; padding: 2px;">  </td> </tr> <tr> <td style="padding: 2px;">Reverse Rotation</td> <td style="text-align: center; padding: 2px;">  </td> </tr> <tr> <td style="padding: 2px;">TSG2nPTSI2 to TSG2nPTSI0</td> <td style="padding: 2px;">[1, 0, 1] [1, 0, 0] [1, 1, 0] [0, 1, 0] [0, 1, 1] [0, 0, 1]</td> </tr> </table> <ul style="list-style-type: none"> Normal or reverse rotation can be detected from the first change of TSG2nPTSI0 to TSG2nPTSI2 after TSnTRG0.TSnTS has been set to 1. For details, see Section 15.7.5 (b), Detection of Input Pattern Order. 	Normal Rotation		Reverse Rotation		TSG2nPTSI2 to TSG2nPTSI0	[1, 0, 1] [1, 0, 0] [1, 1, 0] [0, 1, 0] [0, 1, 1] [0, 0, 1]
Normal Rotation								
Reverse Rotation								
TSG2nPTSI2 to TSG2nPTSI0	[1, 0, 1] [1, 0, 0] [1, 1, 0] [0, 1, 0] [0, 1, 1] [0, 0, 1]							
2 to 0	TSnOPF [2:0]	Indicates the output pattern of the timer output pins (TSG2nO1 to TSG2nO6).						

(13) TSG2n Status Register 2 (TSnSTR2)

This register controls the flags.

Access This register can only be read in 16-bit units.

Address <TSG2n_base1> + 018_H

Initial value 0000_H

This register is initialized by a reset from any source.

15	14	13	12	11	10	9	8	7	6	5	4	3	2	1	0
-	-	-	-	-	-	TSn TBF2	TSn TBF1	TSn TBF0	TSn PPF	TSn PEF	TSn TDF	TSn NDF	TSn PRF	TSn PTF	-
R	R	R	R	R	R	R	R	R	R	R	R	R	R	R	R

Table 15-19 TSnSTR2 Register Contents (1/2)

Bit Position	Bit Name	Function
9	TSnTBF2	<p>Indicates whether the simultaneous active state of the positive phase and inverse phase is detected when TSnCTL1.TSnTBA2 is 1.</p> <p>0: Positive phase (TSG2nO5) and inverse phase (TSG2nO6) are not active simultaneously.</p> <p>1: Positive phase (TSG2nO5) and inverse phase (TSG2nO6) are active simultaneously.</p> <ul style="list-style-type: none"> • TSnTBF2 is set to 1 when the simultaneous active state of the positive phase (TSG2nO5) and inverse phase (TSG2nO6) is detected, and an error interrupt (INTTSG2nIER) is generated. TSnTBF2 can be cleared by writing 1 to TSnSTC.TSnTBR2. • The simultaneous active state is not detected when TSnTBA2 = 0.
8	TSnTBF1	<p>Indicates whether the simultaneous active state of the positive phase and inverse phase is detected when TSnCTL1.TSnTBA1 is 1.</p> <p>0: Positive phase (TSG2nO3) and inverse phase (TSG2nO4) are not active simultaneously.</p> <p>1: Positive phase (TSG2nO3) and inverse phase (TSG2nO4) are active simultaneously.</p> <ul style="list-style-type: none"> • TSnTBF1 is set to 1 when the simultaneous active state of the positive phase (TSG2nO3) and inverse phase (TSG2nO4) is detected, and an error interrupt (INTTSG2nIER) is generated. TSnTBF1 can be cleared by writing 1 to TSnSTC.TSnTBR1. • The simultaneous active state is not detected when TSnTBA1 = 0.
7	TSnTBF0	<p>Indicates whether the simultaneous active state of the positive phase and inverse phase is detected when TSnCTL1.TSnTBA0 is 1.</p> <p>0: Positive phase (TSG2nO1) and inverse phase (TSG2nO2) are not active simultaneously.</p> <p>1: Positive phase (TSG2nO1) and inverse phase (TSG2nO2) are active simultaneously.</p> <ul style="list-style-type: none"> • TSnTBF0 is set to 1 when the simultaneous active state of the positive phase (TSG2nO1) and inverse phase (TSG2nO2) is detected, and an error interrupt (INTTSG2nIER) is generated. TSnTBF0 can be cleared by writing 1 to TSnSTC.TSnTBR0. • The simultaneous active state is not detected when TSnTBA0 = 0.

Table 15-19 TSnSTR2 Register Contents (2/2)

Bit Position	Bit Name	Function
6	TSnPPF	<p>Indicates detection of the difference between the input patterns (TSG2nPTSI0 to TSG2nPTSI2) and the output patterns (TSG2nO1 to TSG2nO6) after they are compared.</p> <p>0: No phase difference detected between the input patterns (TSG2nPTSI0 to TSG2nPTSI2) and the output patterns (TSG2nO1 to TSG2nO6).</p> <p>1: A phase difference detected between the input patterns (TSG2nPTSI0 to TSG2nPTSI2) and the output patterns (TSG2nO1 to TSG2nO6).</p> <ul style="list-style-type: none"> • TSnPPF is set to 1 when a difference between input and output patterns is detected, and a warning interrupt (INTTSG2nIWN) is generated. TSnPPF can be cleared by writing 1 to TSnSTC.TSnPPR. • TSnPPF is valid when TSnOPT0.TSnSOC = 0, TSnPOT = 1, and TSnCTL1.TSnPPC = 1.
5	TSnPEF	<p>Indicates whether an abnormal input (000_B or 111_B) is input to TSG2nPTSI0 to TSG2nPTSI2 is detected.</p> <p>0: No abnormal input (000_B or 111_B) to TSG2nPTSI0 to TSG2nPTSI2 detected.</p> <p>1: Abnormal input (000_B or 111_B) to TSG2nPTSI0 to TSG2nPTSI2 detected.</p> <ul style="list-style-type: none"> • TSnPEF is set to 1 when an input of 000_B or 111_B to TSG2nPTSI0 to TSG2nPTSI2 is detected, and a warning interrupt (INTTSG2nIWN) is generated. TSnPEF can be cleared by writing 1 to TSnSTC.TSnPER.
4	TSnTDF	<p>Indicates whether simultaneous generation of the TSnOPCI0 and TSnOPCI1 triggers is detected.</p> <p>0: Simultaneous generation of the TSnOPCI0 and TSnOPCI1 triggers not detected.</p> <p>1: Simultaneous generation of the TSnOPCI0 and TSnOPCI1 triggers detected.</p> <ul style="list-style-type: none"> • TSnTDF is set to 1 when simultaneous generation of the TSnOPCI0 and TSnOPCI1 triggers is detected, and a warning interrupt (INTTSG2nIWN) is generated. TSnTDF can be cleared by writing 1 to TSnSTC.TSnTDR.
3	TSnNDF	<p>Indicates whether noise on TSG2nPTSI0 to TSG2nPTSI2 is detected.</p> <p>0: Noise on TSG2nPTSI0 to TSG2nPTSI2 due to simultaneous change of two or more pins not detected.</p> <p>1: Noise on TSG2nPTSI0 to TSG2nPTSI2 due to simultaneous change of two or more pins detected.</p> <ul style="list-style-type: none"> • TSnNDF is set to 1 when simultaneous change of two or more pins in TSG2nPTSI0 to TSG2nPTSI2 is detected, and a warning interrupt (INTTSG2nIWN) is generated. TSnNDF can be cleared by writing 1 to TSnSTC.TSnNDR.
2	TSnPRF	<p>Indicates whether reversal of the TSG2nPTSI0 to TSG2nPTSI2 input order is detected.</p> <p>0: The reversal of the TSG2nPTSI0 TSG2nPTSI2 input order not detected.</p> <p>1: The reversal of the TSG2nPTSI0 to TSG2nPTSI2 input order detected.</p> <ul style="list-style-type: none"> • TSnPRF is set to 1 when TSnSTR1.TSnTSF changes, and a warning interrupt (INTTSG2nIWN) is generated. TSnPRF can be cleared by writing 1 to TSnSTC.TSnPRR. Detection is possible from the second TSG2nPTSI0 to TSG2nPTSI2 change timing after setting TSnTRG0.TSnTS = 1.
1	TSnPTE	<p>Indicates whether an abnormal toggle of TSG2nPTSI0 to TSG2nPTSI2 is detected.</p> <p>0: No abnormal toggle of TSG2nPTSI0 to TSG2nPTSI2 detected.</p> <p>1: An abnormal toggle of TSG2nPTSI0 to TSG2nPTSI2 detected.</p> <ul style="list-style-type: none"> • TSnPTE is set to 1 when TSG2nPTSI0 to TSG2nPTSI2 (TSnPTE signal toggle) are changed three times or more during TSnOPCI0 trigger or TSG2nPTSI0 to TSG2nPTSI2 (TSnPTE signal toggle) are changed three times or more during TSnOPCI1 trigger, and a warning interrupt (INTTSG2nIWN) is generated. TSnPTE can be cleared by writing 1 to TSnSTC.TSnPTR.

(14) TSG2n Status Clear Trigger Register (TSnSTC)

This register controls the flags.

Access This register can only be written in 16-bit units.

Address <TSG2n_base1> + 01C_H

Initial value 0000_H

This register is initialized by a reset from any source.

15	14	13	12	11	10	9	8	7	6	5	4	3	2	1	0
-	-	-	-	-	-	TSn TBR2	TSn TBR1	TSn TBR0	TSn PPR	TSn PER	TSn TDR	TSn NDR	TSn PRR	TSn PTR	-
R	R	R	R	R	R	W	W	W	W	W	W	W	W	W	R

Table 15-20 TSnSTC Register Contents (1/2)

Bit Position	Bit Name	Function
9	TSnTBR2	This is a trigger bit that clears TSnSTR2.TSnTBF2. 0: Does not clear TSnTBF2. 1: Clears TSnTBF2. <ul style="list-style-type: none"> When TSnTBR2 writing and TSnSTR2.TSnTBF2 setting occur simultaneously, TSnSTR2.TSnTBF2 setting has a priority, and the flag is not cleared.
8	TSnTBR1	This is a trigger bit that clears TSnSTR2.TSnTBF1. 0: Does not clear TSnTBF1. 1: Clears TSnTBF1. <ul style="list-style-type: none"> When TSnTBR1 writing and TSnSTR2.TSnTBF1 setting occur simultaneously, TSnSTR2.TSnTBF1 setting has a priority, and the flag is not cleared.
7	TSnTBR0	This is a trigger bit that clears TSnSTR2.TSnTBF0. 0: Does not clear TSnTBF0. 1: Clears TSnTBF0. <ul style="list-style-type: none"> When TSnTBR0 writing and TSnSTR2.TSnTBF0 setting occur simultaneously, TSnSTR2.TSnTBF0 setting has a priority, and the flag is not cleared.
6	TSnPPR	This is a trigger bit that clears TSnSTR2.TSnPPF. 0: Does not clear TSnPPF. 1: Clears TSnPPF. <ul style="list-style-type: none"> When TSnPPR writing and TSnSTR2.TSnPPF setting occur simultaneously, TSnSTR2.TSnPPF setting has a priority, and the flag is not cleared.
5	TSnPER	This is a trigger bit that clears TSnSTR2.TSnPEF. 0: Does not clear TSnPEF. 1: Clears TSnPEF. <ul style="list-style-type: none"> When TSnPER writing and TSnSTR2.TSnPEF setting occur simultaneously, TSnSTR2.TSnPEF setting has a priority, and the flag is not cleared.
4	TSnTDR	This is a trigger bit that clears TSnSTR2.TSnTDF. 0: Does not clear TSnTDF. 1: Clears TSnTDF. <ul style="list-style-type: none"> When TSnTDR writing and TSnSTR2.TSnTDF setting occur simultaneously, TSnSTR2.TSnTDF setting has a priority, and the flag is not cleared.

Table 15-20 TSnSTC Register Contents (2/2)

Bit Position	Bit Name	Function
3	TSnNDR	<p>This is a trigger bit that clears TSnSTR2.TSnNDF.</p> <p>0: Does not clear TSnNDF. 1: Clears TSnNDF.</p> <ul style="list-style-type: none"> When TSnNDR writing and TSnSTR2.TSnNDF setting occur simultaneously, TSnSTR2.TSnNDF setting has a priority, and the flag is not cleared.
2	TSnPRR	<p>This is a trigger bit that clears TSnSTR2.TSnPRF.</p> <p>0: Does not clear TSnPRF. 1: Clears TSnPRF.</p> <ul style="list-style-type: none"> When TSnPRR writing and TSnSTR2.TSnPRF setting occur simultaneously, TSnSTR2.TSnPRF setting has a priority, and the flag is not cleared.
1	TSnPTR	<p>This is a trigger bit that clears TSnSTR2.TSnPTF.</p> <p>0: Does not clear TSnPTF. 1: Clears TSnPTF.</p> <ul style="list-style-type: none"> When TSnPTR writing and TSnSTR2.TSnPTF setting occur simultaneously, TSnSTR2.TSnPTF setting has a priority, and the flag is not cleared.

(15) TSG2n Option Register 0 (TSnOPT0)

This register sets the optional functions.

Access This register can be read/written in 8-bit units.

Address <TSG2n_base1> + 020_H

Initial value 00_H

This register is initialized by a reset from any source.

7	6	5	4	3	2	1	0
-	TSn SOC	TSn STE	TSn POT	TSn PSS	TSn IDC	TSn PSC	-
R	R/W	R/W	R/W	R/W	R/W	R/W	R

Table 15-21 TSnOPT0 Register Contents (1/2)

Bit Position	Bit Name	Function
6	TSnSOC	Enables or disables control of the timer output (TSG2nO1 to TSG2nO6 pins) by software. 0: Disables control by software. 1: Enables control by software. <ul style="list-style-type: none"> When TSnSOC is set to 1, timer output is switched to the software control/trigger control output pattern specified by TSnSPC2 to TSnSPC0. The dead time is secured by the dead time counter.
5	TSnSTE	Enables or disables control by the pattern output trigger. 0: Disables the TSG2nPTSI0 to TSG2nPTSI2 and TSnOPCI0, and TSnOPCI1 inputs. 1: Enables TSG2nPTSI0 to TSG2nPTSI2 and TSnOPCI0, and TSnOPCI1 inputs. <ul style="list-style-type: none"> The pattern output trigger is selected by TSnPOT. TSnSTE is valid in 120-DC mode and when software output control function is enabled.
4	TSnPOT	Selects the pattern output trigger. 0: Switches the output pattern by the external pattern input pins (TSG2nPTSI0 to TSG2nPTSI2) (pattern switch method). 1: Switches the output pattern by the rising edge of the TSnOPCI0 and TSnOPCI1 (trigger switch method).
3	TSnPSS	Selects the pattern output order switch factor. 0: The pattern output order is not switched by TSnPSC. 1: The pattern output order is switched by TSnPSC. <ul style="list-style-type: none"> TSnPSS is valid when TSnSTE = 1 and TSnPOT = 1 (trigger switch method). At this time, TSnPSS should be set to 1.
2	TSnIDC	Determines the output pattern from the TSG2nO1 to TSG2nO6 pins in combination with the TSnIDC and TSnSTR1.TSnTSF and TSnPSC signals. For the timer output order and patterns to be output, see Figure 15-74 to Figure 15-77, Example of Operation in 120-DC Mode, in Section 15.11.4 (5), Operation in 120-DC Mode.

Table 15-21 TSnOPT0 Register Contents (2/2)

Bit Position	Bit Name	Function
1	TSnPSC	<p>Selects the pattern output order when the semi-automatic cruise function is enabled.</p> <p>0: Switches the timer output (TSG2nO1 to TSG2nO6) in the normal rotation. 1: Switches the timer output (TSG2nO1 to TSG2nO6) in the reverse rotation.</p> <ul style="list-style-type: none"> • TSnPSC specifies the timer output pattern order assuming the output pattern specified by TSnSPC2 to TSnSPC0 as the initial pattern. TSnPSC is valid when TSnPOT = 1 and TSnPSS = 1. • It is recommended to rewrite TSnPSC when TSnSTR0.TSnTE = 0 or TSnPOT = 0. If TSnPSC is rewritten when TSnPOT = 1, the unexpected timer output pattern might be caused. • If the signal input to TSG2nPTSI0 to TSG2nPTSI2 changes with TSG2n operation being stopped (TSnSTR0.TSnTE = 0), the TSnTRG0.TSnTS bit should be set to 1 after matching the input signal change logic with the TSnPSC order. • For output order in normal or reverse rotation, see Section 15.11.4, 120-DC Mode. Here, normal rotation and reverse rotation refer to the change of output, and they are different from normal rotation and reverse rotation of a motor.

(16) TSG2n Option Register 1 (TSnOPT1)

This register sets the optional functions.

Access This register can be read/written in 8-bit units.

Address <TSG2n_base1> + 024_H

Initial value 00_H

This register is initialized by a reset from any source.

7	6	5	4	3	2	1	0
-	-	-	-	-	TSnSPC[2:0]		
R	R	R	R	R	R/W	R/W	R/W

Table 15-22 TSnOPT1 Register Contents

Bit Position	Bit Name	Function
2 to 0	TSnSPC [2:0]	Specifies the timer output pattern when software output function is enabled and in 120-DC mode. For the output pattern, see Section 15.11.5, Software Output Control Function, and Section 15.11.4, 120-DC Mode.

(17) TSG2n Trigger Register 0 (TSnTRG0)

This register controls the start of the timer.

Access This register can only be written in 8-bit units.

Address <TSG2n_base1> + 030_H

Initial value 00_H

This register is initialized by a reset from any source.

7	6	5	4	3	2	1	0
-	-	-	-	-	-	-	TSn TS
R	R	R	R	R	R	R	W

Table 15-23 TSnTRG0 Register Contents

Bit Position	Bit Name	Function
0	TSnTS	This bit is a trigger bit that controls the start of the timer. 0: The timer is not started. 1: The timer is started (restarted) (TSnSTR0.TSnTE = 1). • This bit is always read as 0.

(18) TSG2n Trigger Register 1 (TSnTRG1)

This register controls the stop of the timer.

Access This register can only be written in 8-bit units.

Address <TSG2n_base1> + 034_H

Initial value 00_H

This register is initialized by a reset from any source.

7	6	5	4	3	2	1	0
-	-	-	-	-	-	-	TSn TT
R	R	R	R	R	R	R	W

Table 15-24 TSnTRG1 Register Contents

Bit Position	Bit Name	Function
0	TSnTT	This is a trigger bit that controls the stop of the timer. 0: The timer is not stopped. 1: The timer is stopped (TSnSTR0.TSnTE = 0). • This bit is always read as 0.

(19) TSG2n Counter Read Buffer Register (TSnCNT)

From this register the counter value can be read.

Access This register can only be read in 16-bit units.

Address <TSG2n_base1> + 028_H

Initial value 0000_H

This register is initialized by a reset from any source.

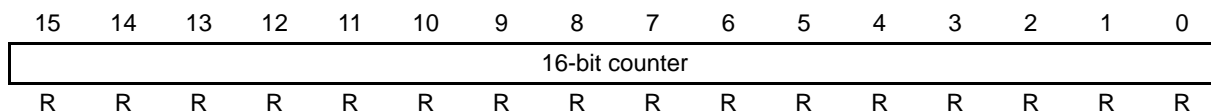

16-bit counter This register is a timer read buffer register from which the 16-bit counter value can be read. In HT-PWM mode, the 16-bit counter provides the triangle wave control in which the counter value is incremented and decremented by 2. Bit 0 is always read as 0.

In other modes, the 16-bit counter provides the sawtooth wave control in which the counter value is incremented by 1.

Table 15-25 TSnCNT Register Count Value

Operating Mode	At the Beginning	Minimum Value	Maximum Value
HT-PWM mode	TSnDTC0	TSnDTC0	TSnDTC0 + TSnCMP0*
Other modes	0000 _H	0000 _H	TSnCMP0

Note: * Use with the set value of TSnDTC0+TSnCMP0 < FFFF_H.

(20) TSG2n Sub-Counter Read Buffer Register (TSnSBC)

From this register the sub-counter value can be read.

Access This register can only be read in 16-bit units.

Address <TSG2n_base1> + 02C_H

Initial value 0000_H

This register is initialized by a reset from any source.

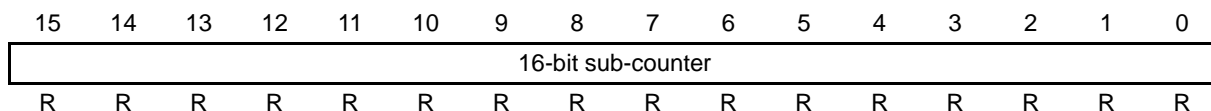

16-bit sub-counter This register is a timer read buffer register from which the 16-bit sub-counter value can be read. In HT-PWM mode, the 16-bit sub-counter provides the triangle wave control in which the counter value is incremented and decremented by 2. Bit 0 is always read as 0. (This register can be used only in HT-PWM mode.)

Table 15-26 TSnSBC Register Count Value

Operating Mode	At the Beginning	Minimum Value	Maximum Value
HT-PWM mode	TSnDTC0	0000 _H	TSnDTC0 + TSnDTC1 + TSnCMP0*
Other modes	0000 _H	0000 _H	0000 _H

Note: * Use with the set value of TSnDTC0 + TSnDTC1 + TSnCMP0 < FFFF_H.

(21) TSG2n Compare Register 0 (TSnCMP0)

This register specifies the PWM period.

Access This register can be read/written in 32-bit units.

Address <TSG2n_base1> + 058_H

Initial value 00000000_H

This register is initialized by a reset from any source.

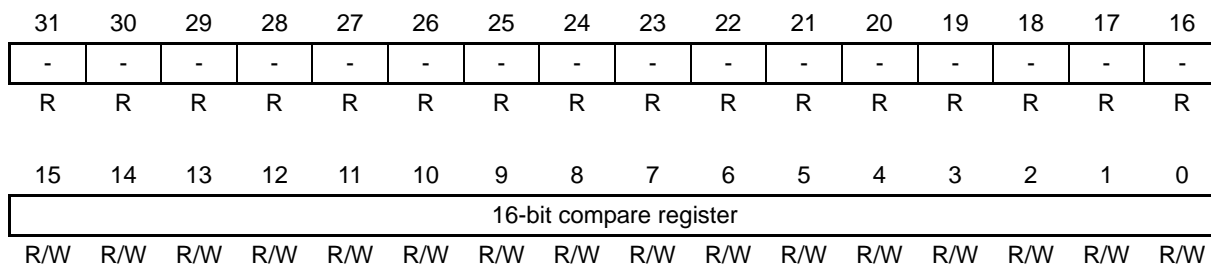

Table 15-27 TSnCMP0 Register Setting

Operating Mode	PWM Period	Minimum Value (Period)	Maximum Value (Period)
HT-PWM mode	TSnCMP0*	0002 _H	FFFE _H
Other modes	TSnCMP0 + 1	1 (TSnCMP0 = 0000 _H)	10000 _H (TSnCMP0 = FFFF _H)

Note: * In HT-PWM mode, the LSB is ignored.

(22) TSG2n Compare Register 1, 2 (TSnCMP1W)

This register specifies the compare value.

Access This register can be read/written in 32-bit units.

Address <TSG2n_base1> + 040_H

Initial value 00000000_H

This register is initialized by a reset from any source.

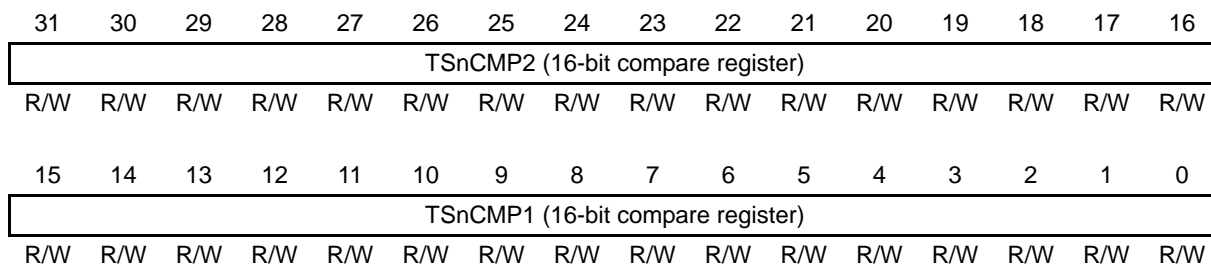

Table 15-28 TSnCMP1W Register Setting

Operating Mode	TSnCMP1	TSnCMP2	Minimum Value	Maximum Value
PWM mode	TSG2nO1 clear timing	TSG2nO1 set timing	0000 _H	TSnCMP0 + 1 (TSnCMP0 < FFFF _H) or FFFF _H
HT-PWM mode	TSG2nO1 clear timing/TSG2nO2 set timing	TSG2nO1 set timing/TSG2nO2 clear timing	0000 _H	TSnCMP0 + TSnDTC0 + TSnDTC1
SP-PWM mode	TSG2nO1 clear timing/TSG2nO2 set timing	TSG2nO1 set timing/TSG2nO2 clear timing	0000 _H	TSnCMP0 + 1 (TSnCMP0 < FFFF _H) or FFFF _H
120-DC mode	Duty when TSG2nO1, TSG2nO3, or TSG2nO5 output pattern is selected by TSnPAT0	Duty when TSG2nO1, TSG2nO3, or TSG2nO5 output pattern is selected by TSnPAT0	0000 _H	TSnCMP0 + 1 (TSnCMP0 < FFFF _H) or FFFF _H

Note The dead time function is enabled in all operating modes.
 In HT-PWM mode, the match timing between this register and TSnSBC is used.
 In 120-DC mode, the output from TSG2nO1 to TSG2nO6 is controlled by TSnCMPm, TSnPAT0, and TSnPAT1.

(23) TSG2n Compare Register 3, 4 (TSnCMP3W)

This register specifies the compare value.

Access This register can be read/written in 32-bit units.

Address <TSG2n_base1> + 04C_H

Initial value 00000000_H

This register is initialized by a reset from any source.

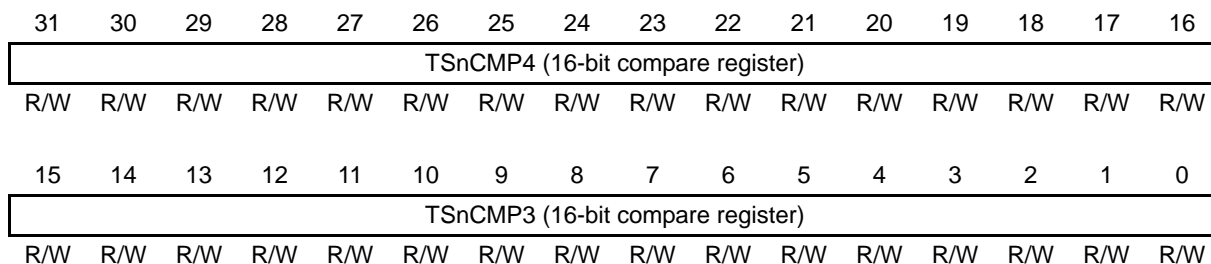

Table 15-29 TSnCMP3W Register Setting

Operating Mode	TSnCMP3	TSnCMP4	Minimum Value	Maximum Value
PWM mode	TSG2nO2 clear timing	TSG2nO2 set timing	0000 _H	TSnCMP0 + 1 (TSnCMP0 < FFFF _H) or FFFF _H
HT-PWM mode	-	-	-	-
SP-PWM mode	-	-	-	-
120-DC mode	Duty when TSG2nO2, TSG2nO4, or TSG2nO6 output pattern is selected by TSnPAT1	Duty when TSG2nO2, TSG2nO4, or TSG2nO6 output pattern is selected by TSnPAT1	0000 _H	TSnCMP0 + 1 (TSnCMP0 < FFFF _H) or FFFF _H

Note The dead time function is enabled in all operating modes. In 120-DC mode, the output from TSG2nO1 to TSG2nO6 is controlled by TSnCMPm, TSnPAT0, and TSnPAT1.

(24) TSG2n Compare Register 5, 6 (TSnCMP5W)

This register specifies the compare value.

Access This register can be read/written in 32-bit units.

Address <TSG2n_base1> + 044_H

Initial value 00000000_H

This register is initialized by a reset from any source.

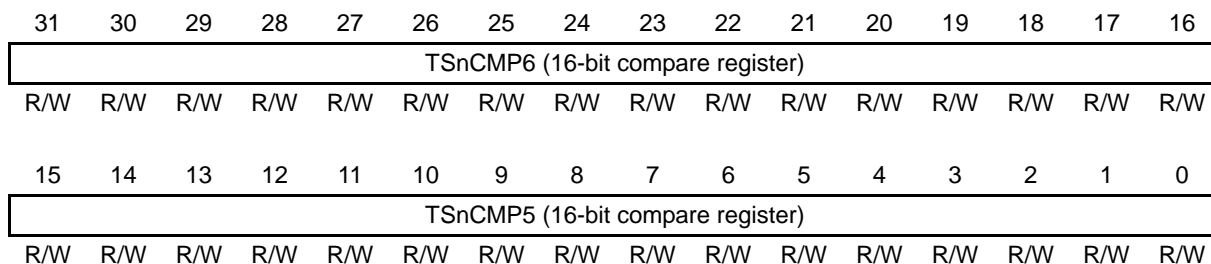

Table 15-30 TSnCMP5W Register Setting

Operating Mode	TSnCMP5	TSnCMP6	Minimum Value	Maximum Value
PWM mode	TSG2nO3 clear timing	TSG2nO3 set timing	0000 _H	TSnCMP0 + 1 (TSnCMP0 < FFFF _H) or FFFF _H
HT-PWM mode	TSG2nO3 clear timing/TSG2nO4 set timing	TSG2nO3 set timing/TSG2nO4 clear timing	0000 _H	TSnCMP0 + TSnDTC0 + TSnDTC1
SP-PWM mode	TSG2nO3 clear timing/TSG2nO4 set timing	TSG2nO3 set timing/TSG2nO4 clear timing	0000 _H	TSnCMP0 + 1 (TSnCMP0 < FFFF _H) or FFFF _H
120-DC mode	Duty when TSG2nO1, TSG2nO3, or TSG2nO5 output pattern is selected by TSnPAT0	Duty when TSG2nO1, TSG2nO3, or TSG2nO5 output pattern is selected by TSnPAT0	0000 _H	TSnCMP0 + 1 (TSnCMP0 < FFFF _H) or FFFF _H

Note The dead time function is enabled in all operating modes.
 In HT-PWM mode, match timing between this register and TSnSBC is used.
 In 120-DC mode, the output from TSG2nO1 to TSG2nO6 is controlled by TSnCMPm, TSnPAT0, and TSnPAT1.

(25) TSG2n Compare Register 7, 8 (TSnCMP7W)

This register specifies the compare value.

Access This register can be read/written in 32-bit units.

Address <TSG2n_base1> + 050_H

Initial value 00000000_H

This register is initialized by a reset from any source.

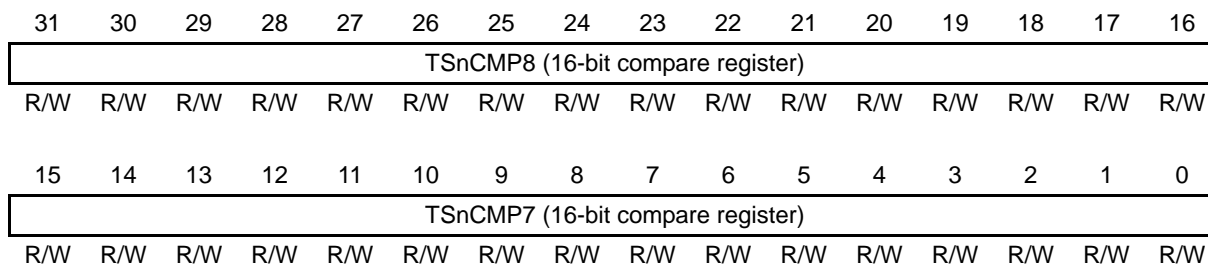

Table 15-31 TSnCMP7W Register Setting

Operating Mode	TSnCMP7	TSnCMP8	Minimum Value	Maximum Value
PWM mode	TSG2nO4 clear timing	TSG2nO4 set timing	0000 _H	TSnCMP0 + 1 (TSnCMP0 < FFFF _H) or FFFF _H
HT-PWM mode	-	-	-	-
SP-PWM mode	-	-	-	-
120-DC mode	Duty when TSG2nO2, TSG2nO4, or TSG2nO6 output pattern is selected by TSnPAT1	Duty when TSG2nO2, TSG2nO4, or TSG2nO6 output pattern is selected by TSnPAT1	0000 _H	TSnCMP0 + 1 (TSnCMP0 < FFFF _H) or FFFF _H

Note The dead time function is enabled in all operating modes. In 120-DC mode, the output from TSG2nO1 to TSG2nO6 is controlled by TSnCMPm, TSnPAT0, and TSnPAT1.

(26) TSG2n Compare Register 9, 10 (TSnCMP9W)

This register specifies the compare value.

Access This register can be read/written in 32-bit units.

Address <TSG2n_base1> + 048_H

Initial value 00000000_H

This register is initialized by a reset from any source.

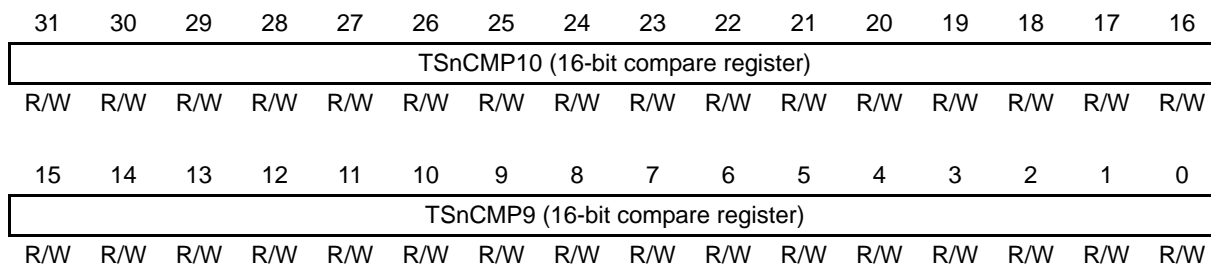

Table 15-32 TSnCMP9W Register Setting

Operating Mode	TSnCMP9	TSnCMP10	Minimum Value	Maximum Value
PWM mode	TSG2nO5 clear timing	TSG2nO5 set timing	0000 _H	TSnCMP0 + 1 (TSnCMP0 < FFFF _H) or FFFF _H
HT-PWM mode	TSG2nO5 clear timing/TSG2nO6 set timing	TSG2nO5 set timing/TSG2nO6 clear timing	0000 _H	TSnCMP0 + TSnDTC0 + TSnDTC1
SP-PWM mode	TSG2nO5 clear timing/TSG2nO6 set timing	TSG2nO5 set timing/TSG2nO6 clear timing	0000 _H	TSnCMP0 + 1 (TSnCMP0 < FFFF _H) or FFFF _H
120-DC mode	Duty when TSG2nO1, TSG2nO3, or TSG2nO5 output pattern is selected by TSnPAT0	Duty when TSG2nO1, TSG2nO3, or TSG2nO5 output pattern is selected by TSnPAT0	0000 _H	TSnCMP0 + 1 (TSnCMP0 < FFFF _H) or FFFF _H

Note The dead time function is enabled in all operating modes.
 In HT-PWM mode, the match timing between this register and TSnSBC is used.
 In 120-DC mode, the output from TSG2nO1 to TSG2nO6 is controlled by TSnCMPm, TSnPAT0, and TSnPAT1.

(27) TSG2n Compare Register 11, 12 (TSnCMP11W)

This register specifies the compare value.

Access This register can be read/written in 32-bit units.

Address <TSG2n_base1> + 054_H

Initial value 00000000_H

This register is initialized by a reset from any source.

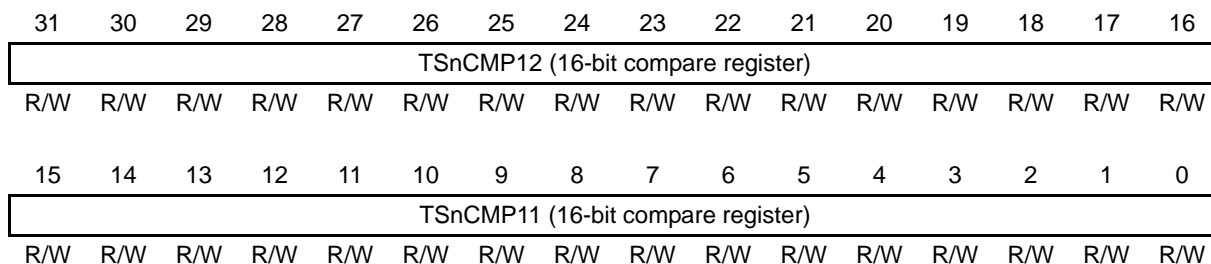

Table 15-33 TSnCMP11W Register Setting

Operating Mode	TSnCMP11	TSnCMP12	Minimum Value	Maximum Value
PWM mode	TSG2nO6 clear timing	TSG2nO6 set timing	0000 _H	TSnCMP0 + 1 (TSnCMP0 < FFFF _H) or FFFF _H
HT-PWM mode	-	-	-	-
SP-PWM mode	-	-	-	-
120-DC mode	Duty when TSG2nO2, TSG2nO4, or TSG2nO6 output pattern is selected by TSnPAT1	Duty when TSG2nO2, TSG2nO4, or TSG2nO6 output pattern is selected by TSnPAT1	0000 _H	TSnCMP0 + 1 (TSnCMP0 < FFFF _H) or FFFF _H

Note The dead time function is used in all operating modes.
 In 120-DC mode, the output from TSG2nO1 to TSG2nO6 is controlled by TSnCMPm, TSnPAT0, and TSnPAT1.

(28) TSG2n Compare Register 1 to 12 (TSnCMP1 to TSnCMP12)

This register specifies the compare value.

Access This register can be read/written in 16-bit units.

- Address** TSnCMP1 <TSG2n_base1> + 080_H
 TSnCMP2 <TSG2n_base1> + 084_H
 TSnCMP3 <TSG2n_base1> + 098_H
 TSnCMP4 <TSG2n_base1> + 09C_H
 TSnCMP5 <TSG2n_base1> + 088_H
 TSnCMP6 <TSG2n_base1> + 08C_H
 TSnCMP7 <TSG2n_base1> + 0A0_H
 TSnCMP8 <TSG2n_base1> + 0A4_H
 TSnCMP9 <TSG2n_base1> + 090_H
 TSnCMP10 <TSG2n_base1> + 094_H
 TSnCMP11 <TSG2n_base1> + 0A8_H
 TSnCMP12 <TSG2n_base1> + 0AC_H

Initial value 0000_H

This register is initialized by a reset from any source.

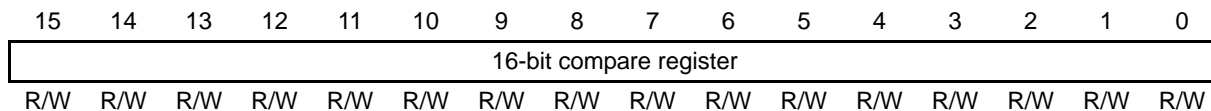

The function of this register is the same as the function of the corresponding registers with the same name in TSnCMP1W, TSnCMP3W, TSnCMP5W, TSnCMP7W, TSnCMP9W, and TSnCMP11W. (When this register is accessed, it is reflected to the register with the same name.)

(29) TSG2n Diagnostic Output Compare Register 0, 1 (TSnDCMP0W)

This register specifies the compare value.

Access This register can be read/written in 32-bit units.

Address <TSG2n_base1> + 05C_H

Initial value 00000000_H

This register is initialized by a reset from any source.

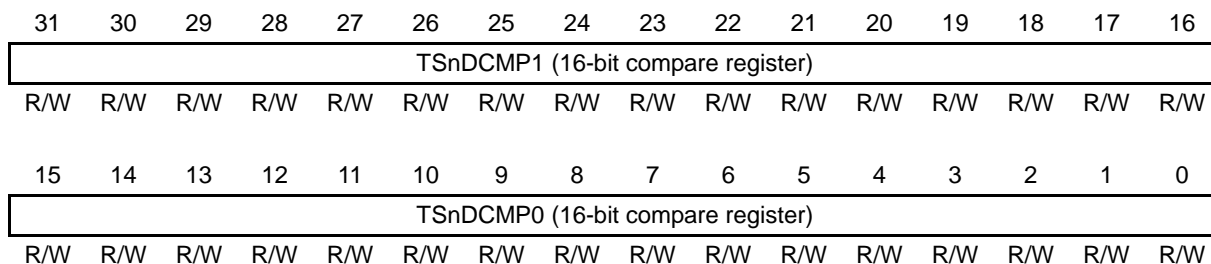

Setting of this register is used to control the diagnostic output or A/D conversion trigger timing in all the modes. A pulse is generated by a match of this register value with the 16-bit counter value.

(30) TSG2n Diagnostic Output Compare Register 2 (TSnDCMP2)

This register specifies the compare value.

Access This register can be read/written in 32-bit units.

Address <TSG2n_base1> + 060_H

Initial value 00000000_H

This register is initialized by a reset from any source.

31	30	29	28	27	26	25	24	23	22	21	20	19	18	17	16
-	-	-	-	-	-	-	-	-	-	-	-	-	-	-	-
R	R	R	R	R	R	R	R	R	R	R	R	R	R	R	R
15	14	13	12	11	10	9	8	7	6	5	4	3	2	1	0
TSnDCMP2 (16-bit compare register)															
R/W	R/W	R/W	R/W	R/W	R/W	R/W	R/W	R/W	R/W	R/W	R/W	R/W	R/W	R/W	R/W

Setting of this register is used to control the diagnostic output or A/D conversion trigger timing in all the modes. A pulse is generated by a match of this register value with the 16-bit counter value.

(31) TSG2n Pattern Register 0 (TSnPAT0W)

This register specifies the output pattern.

Access This register can be read/written in 32-bit units.

Address <TSG2n_base1> + 064_H

Initial value 00000000_H

This register is initialized by a reset from any source.

31	30	29	28	27	26	25	24	23	22	21	20	19	18	17	16
-	-	-	-	-	-	-	-	-	-	-	-	-	-	-	PAT5T
R	R	R	R	R	R	R	R	R	R	R	R	R	R	R	R/W
15	14	13	12	11	10	9	8	7	6	5	4	3	2	1	0
PAT5T	PAT4T		PAT3T			PAT2T			PAT1T			PAT0T			
R/W	R/W	R/W	R/W	R/W	R/W	R/W	R/W	R/W	R/W	R/W	R/W	R/W	R/W	R/W	R/W

Output pattern This register controls UT/VT/WT output in 120-DC mode.

Table 15-34 TSnPAT0W Set Value and Output Control

PATmT value	Output Control
000	Fixed to low.
001	PWM output set by TSnCMP1
010	PWM output set by TSnCMP2
011	PWM output set by TSnCMP5
100	PWM output set by TSnCMP6
101	PWM output set by TSnCMP9
110	PWM output set by TSnCMP10
111	Fixed to high.

(m = 0, 1, 2, 3, 4, 5)

(32) TSG2n Pattern Register 1 (TSnPAT1W)

This register specifies the output pattern.

Access This register can be read/written in 32-bit units.

Address <TSG2n_base1> + 068_H

Initial value 00000000_H

This register is initialized by a reset from any source.

31	30	29	28	27	26	25	24	23	22	21	20	19	18	17	16
-	-	-	-	-	-	-	-	-	-	-	-	-	-	-	PAT5B
R	R	R	R	R	R	R	R	R	R	R	R	R	R	R	R/W
15	14	13	12	11	10	9	8	7	6	5	4	3	2	1	0
PAT5B	PAT4B		PAT3B			PAT2B			PAT1B			PAT0B			
R/W	R/W	R/W	R/W	R/W	R/W	R/W	R/W	R/W	R/W	R/W	R/W	R/W	R/W	R/W	R/W

Output pattern This register controls UB/VB/WB output in 120-DC mode.

Table 15-35 TSnPAT1W Set Value and Output Control

PATmB value	Output Control
000	Fixed to low.
001	PWM output set by TSnCMP3
010	PWM output set by TSnCMP4
011	PWM output set by TSnCMP7
100	PWM output set by TSnCMP8
101	PWM output set by TSnCMP11
110	PWM output set by TSnCMP12
111	Fixed to high.

(m = 0, 1, 2, 3, 4, 5)

(33) TSG2n Dead Time Setting Register 0 (TSnDTC0W)

This register sets the dead time value (the period from inverse phase inactivation to positive phase activation).

Access This register can be read/written in 32-bit units.

Address <TSG2n_base1> + 06C_H

Initial value 00000000_H

This register is initialized by a reset from any source.

31	30	29	28	27	26	25	24	23	22	21	20	19	18	17	16
Write protection code check															
R	W	W	W	W	W	W	W	W	W	W	W	W	W	W	W
15	14	13	12	11	10	9	8	7	6	5	4	3	2	1	0
TSnDTC0 (10-bit dead time compare)															
R	R	R	R	R	R	R/W	R/W	R/W	R/W	R/W	R/W	R/W	R/W	R/W	R/W

To rewrite TSnDTC0W[0:9], set bit 14 to bit 0 and TSnDTCM to 0 in TSnDTPR, and rewrite the TSnDTC0W. At this time, when the rewritten value of TSnDTC0W[30:16] and the TSnDTPR value match, TSnDTC0W is rewritten.

During timer operation (TSnSTR0.TSnTE = 1), rewriting should be performed in reload mode (TSnCTL3.TSnRMC = 0).

(34) TSG2n Dead Time Setting Register 1 (TSnDTC1W)

This register sets the dead time (the period from positive phase inactivation to inverse phase activation).

Access This register can be read/written in 32-bit units.

Address <TSG2n_base1> + 070_H

Initial value 00000000_H

This register is initialized by a reset from any source.

31	30	29	28	27	26	25	24	23	22	21	20	19	18	17	16
-	Write protection code check														
R	W	W	W	W	W	W	W	W	W	W	W	W	W	W	W
15	14	13	12	11	10	9	8	7	6	5	4	3	2	1	0
-	-	-	-	-	-	TSnDTC1 (10-bit dead time compare)									
R	R	R	R	R	R	R/W	R/W	R/W	R/W	R/W	R/W	R/W	R/W	R/W	R/W

To rewrite TSnDTC1W[0:9], set bit 30 to bit 16 and TSnDTCM to 0 in TSnDTPR, and rewrite the TSnDTC1W. At this time, when the rewritten value of TSnDTC1W[30:16] and the TSnDTPR value match, TSnDTC1W is rewritten.

During timer operation (TSnSTR0.TSnTE = 1), rewriting should be performed in reload mode (TSnCTL3.TSnRMC = 0).

(35) TSG2n HT-PWM U Phase Compare Register (TSnCMPU)

This register sets the compare value for U phase in HT-PWM mode.

Access This register can be read/written in 16-bit units.

Address <TSG2n_base1> + 0B0_H

Initial value 0000_H

This register is initialized by a reset from any source.

15	14	13	12	11	10	9	8	7	6	5	4	3	2	1	0
TSnCMPU (16-bit compare register)															
R/W	R/W	R/W	R/W	R/W	R/W	R/W	R/W	R/W	R/W	R/W	R/W	R/W	R/W	R/W	R/W

Note 1. This register can be used only in HT-PWM mode.

Note 2. The TSnCMPU set value is indicated on TSnCMP1W (TSnCMP1, TSnCMP2).

Note 3. When the TSnCMPU is read, the TSnCMP1 value is actually read.

(36) TSG2n HT-PWM V Phase Compare Register (TSnCMPV)

This register sets the compare value for V phase in HT-PWM mode.

Access This register can be read/written in 16-bit units.

Address <TSG2n_base1> + 0B4_H

Initial value 0000_H

This register is initialized by a reset from any source.

15	14	13	12	11	10	9	8	7	6	5	4	3	2	1	0
TSnCMPV (16-bit compare register)															
R/W	R/W	R/W	R/W	R/W	R/W	R/W	R/W	R/W	R/W	R/W	R/W	R/W	R/W	R/W	R/W

Note 1. This register can be used only in HT-PWM mode.

Note 2. The TSnCMPV set value is indicated on TSnCMP5W (TSnCMP5, TSnCMP6).

Note 3. When the TSnCMPV is read, the TSnCMP5 value is actually read.

(37) TSG2n HT-PWM W Phase Compare Register (TSnCMPW)

This register sets the compare value for W phase in HT-PWM mode.

Access This register can be read/written in 16-bit units.

Address <TSG2n_base1> + 0B8_H

Initial value 0000_H

This register is initialized by a reset from any source.

15	14	13	12	11	10	9	8	7	6	5	4	3	2	1	0
TSnCMPW (16-bit compare register)															
R/W	R/W	R/W	R/W	R/W	R/W	R/W	R/W	R/W	R/W	R/W	R/W	R/W	R/W	R/W	R/W

Note 1. This register can be used only in HT-PWM mode.

Note 2. The TSnCMPW set value is indicated on TSnCMP9W (TSnCMP9, TSnCMP10).

Note 3. When the TSnCMPW is read, the TSnCMP9 value is actually read.

(38) TSG2n SP-PWM U Phase Active Width Setting Register (TSnUPW)

This register sets the active width for U phase in SP-PWM mode.

Access This register can be read/written in 16-bit units.

Address <TSG2n_base1> + 0BC_H

Initial value 0000_H

This register is initialized by a reset from any source.

15	14	13	12	11	10	9	8	7	6	5	4	3	2	1	0
TSnUPW (16-bit compare register)															
R/W	R/W	R/W	R/W	R/W	R/W	R/W	R/W	R/W	R/W	R/W	R/W	R/W	R/W	R/W	R/W

Note 1. This register can be used only in SP-PWM mode.

Note 2. The sum of the TSnUPW set value and the TSnCMP2 set value is indicated on TSnCMP1.

Note 3. When the TSnUPW is read, the TSnCMP1 value is actually read.

(39) TSG2n SP-PWM V Phase Active Width Setting Register (TSnVPW)

This register sets the active width for V phase in SP-PWM mode.

Access This register can be read/written in 16-bit units.

Address <TSG2n_base1> + 0C0_H

Initial value 0000_H

This register is initialized by a reset from any source.

15	14	13	12	11	10	9	8	7	6	5	4	3	2	1	0
TSnVPW (16-bit compare register)															
R/W	R/W	R/W	R/W	R/W	R/W	R/W	R/W	R/W	R/W	R/W	R/W	R/W	R/W	R/W	R/W

Note 1. This register can be used only in SP-PWM mode.

Note 2. The sum of the TSnVPW set value and the TSnCMP6 set value is indicated on TSnCMP5.

Note 3. When the TSnVPW is read, the TSnCMP5 value is actually read.

(40) TSG2n SP-PWM W Phase Active Width Setting Register (TSnWPW)

This register sets the active width for W phase in SP-PWM mode.

Access This register can be read/written in 16-bit units.

Address <TSG2n_base1> + 0C4_H

Initial value 0000_H

This register is initialized by a reset from any source.

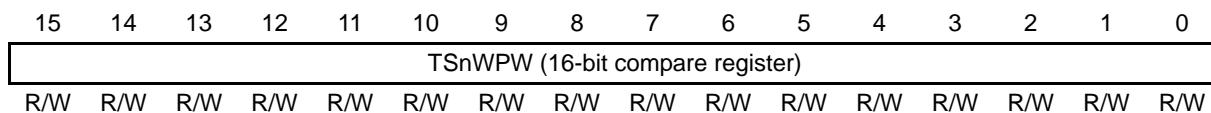

-
- Note 1. This register can be used only in SP-PWM mode.
 - Note 2. The sum of the TSnWPW set value and the TSnCMP10 set value is indicated on TSnCMP9.
 - Note 3. When the TSnWPW is read, the TSnCMP9 value is actually read.
-

(41) TSG2n Dead Time Protection Register (TSnDTPR)

This register controls protection of the write access to the dead time register.

Access This bit can be read/written in 16-bit units.

Address <TSG2n_base0> + 210_H

Initial value 0000_H

This register is initialized by a reset from any source.

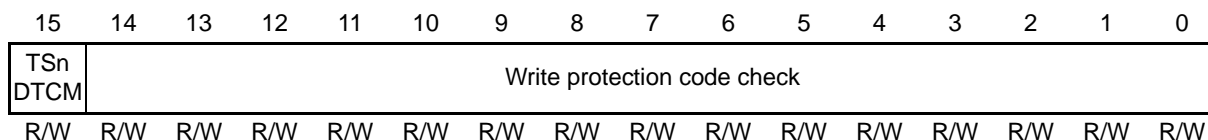

Table 15-36 TSnDTPR Register Contents

Bit Position	Bit Name	Function
15	TSnDTCM	Enables or disables rewriting of TSnDTC0 and TSnDTC1. 0: Enables rewriting of TSnDTC0 and TSnDTC1. 1: Disables rewriting of TSnDTC0 and TSnDTC1.
14 to 0	TSnDTPR [14:0]	Sets the write protection code (any value from 0000 to 7FFF).

This register protects TSnDTC0 and TSnDTC1 from illegal rewriting.

Functions are described below.

- TSnDTCM enables or disables rewriting of TSnDTC0 and TSnDTC1.
- Rewriting of TSnDTC0 and TSnDTC1 is enabled or disabled by checking a match of the write protection code (bits 30 to 16) of TSnDTC0 with TSnDTC1 and the write protection code of TSnDTPR, and the TSnDTCM setting.

Caution This register should be set when the timer is stopped (TSnSTR0.TSnTE = 0). Only the same value can be written during timer operation (TSnSTR0.TSnTE = 1). If the different value is written to this register when TSnSTR0.TSnTE = 1, timer operation cannot be guaranteed. If this register is erroneously rewritten, set this register again after stopping the timer.

15.5 Basic Operation

15.5.1 Basic Operation of 16-Bit Counter

The basic operation of the 16-bit counter is described. For details, see Section 15.11, Operating Modes.

Counting start The 16-bit counter of TSG2n starts counting from the initial value 0000_H in all modes except for HT-PWM mode.

The counter increments from 0000_H, 0001_H, 0002_H, 0003_H, ... in all modes except for HT-PWM mode.

Counter clear The 16-bit counter is cleared by the match of the counter value and the compare register set value.

Counter read during counting In the TSG2n, the 16-bit counter value during counting can be read through TSnCNT.

Interrupt operation

In the TSG2n, the following interrupts are generated.

- INTTSG2nI00: A period interrupt by a match of the 16-bit counter value with the TSnDTC0 value in HT-PWM mode. A compare match interrupt of the 16-bit counter value with the TSnCMP0 buffer register in any mode other than HT-PWM mode.
- INTTSG2nI01: A compare match interrupt of the 16-bit counter value with the TSnCMP1 buffer register.
- INTTSG2nI02: A compare match interrupt of the 16-bit counter value with the TSnCMP2 buffer register.
- INTTSG2nI03: A compare match interrupt of the 16-bit counter value with the TSnCMP3 buffer register.
- INTTSG2nI04: A compare match interrupt of the 16-bit counter value with the TSnCMP4 buffer register.
- INTTSG2nI05: A compare match interrupt of the 16-bit counter value with the TSnCMP5 buffer register.
- INTTSG2nI06: A compare match interrupt of the 16-bit counter value with the TSnCMP6 buffer register.
- INTTSG2nI07: A compare match interrupt of the 16-bit counter value with the TSnCMP7 buffer register.
- INTTSG2nI08: A compare match interrupt of the 16-bit counter value with the TSnCMP8 buffer register.
- INTTSG2nI09: A compare match interrupt of the 16-bit counter value with the TSnCMP9 buffer register.
- INTTSG2nI10: A compare match interrupt of the 16-bit counter value with the TSnCMP10 buffer register.
- INTTSG2nI11: A compare match interrupt of the 16-bit counter value with the TSnCMP11 buffer register.
- INTTSG2nI12: A compare match interrupt of the 16-bit counter value with the TSnCMP12 buffer register.
- INTTSG2nIPEK: A peak interrupt when the 16-bit counter switches from incrementing to decrementing.
- INTTSG2nIVLY: A valley interrupt when the 16-bit counter switches from decrementing to incrementing.
- INTTSG2nIER: A simultaneous active state detection interrupt of the positive phase and inverse phase
- INTTSG2nIWN: A warning detection interrupt

15.5.2 Functions of Compare Registers

The functions of the compare registers in each operating mode are shown in Table 15-37.

Table 15-37 Compare Register Functions in Each Mode (1/4)

Operating Mode	TSnCMP0	TSnCMP1W	TSnCMP3W	TSnCMP5W
PWM mode	Setting PWM period	TSnCMP1: Setting TSG2nO1 clear timing TSnCMP2: Setting TSG2nO1 set timing	TSnCMP3: Setting TSG2nO2 clear timing TSnCMP4: Setting TSG2nO2 set timing	TSnCMP5: Setting TSG2nO3 clear timing TSnCMP6: Setting TSG2nO3 set timing
HT-PWM mode	Setting PWM period	TSnCMP1: Setting TSG2nO1 clear timing and TSG2nO2 set timing TSnCMP2: Setting TSG2nO1 set timing and TSG2nO2 clear timing	-	TSnCMP5: Setting TSG2nO3 clear timing and TSG2nO4 set timing TSnCMP6: Setting TSG2nO3 set timing and TSG2nO4 clear timing
SP-PWM mode	Setting PWM period	TSnCMP1: Setting TSG2nO1 clear timing and TSG2nO2 set timing TSnCMP2: Setting TSG2nO1 set timing and TSG2nO2 clear timing	-	TSnCMP5: Setting TSG2nO3 clear timing and TSG2nO4 set timing TSnCMP6: Setting TSG2nO3 set timing and TSG2nO4 clear timing
120-DC mode	Setting PWM period	TSnCMP1, TSnCMP2: Selecting TSG2nO1, TSG2nO3, and TSG2nO5 outputs by TSnPAT0.	TSnCMP3, TSnCMP4: Selecting TSG2nO2, TSG2nO4, and TSG2nO6 outputs by TSnPAT1.	TSnCMP5, TSnCMP6: Selecting TSG2nO1, TSG2nO3, and TSG2nO5 outputs by TSnPAT0.

Table 15-37 Compare Register Functions in Each Mode (2/4)

Operating Mode	TSnCMP7W	TSnCMP9W	TSnCMP11W	TSnCMP1 to TSnCMP12
PWM mode	TSnCMP7: Setting TSG2nO4 clear timing TSnCMP8: Setting TSG2nO4 set timing	TSnCMP9: Setting TSG2nO5 clear timing TSnCMP10: Setting TSG2nO5 set timing	TSnCMP11: Setting TSG2nO6 clear timing TSnCMP12: Setting TSG2nO6 set timing	See TSNCMP1W to TSnCMP11W.
HT-PWM mode	-	TSnCMP9: Setting TSG2nO5 clear timing and TSG2nO6 set timing TSnCMP10: Setting TSG2nO5 set timing and TSG2nO6 clear timing	-	See TSnCMP1W, TSnCMP5W, and TSnCMP9W.
SP-PWM mode	-	TSnCMP9: Setting TSG2nO5 clear timing and TSG2nO6 set timing TSnCMP10: Setting TSG2nO5 set timing and TSG2nO6 clear timing	-	See TSnCMP1W, TSnCMP5W, and TSnCMP9W.
120-DC mode	TSnCMP7, TSnCMP8: Selecting TSG2nO2, TSG2nO4, and TSG2nO6 outputs by TSnPAT1.	TSnCMP9, TSnCMP10: Selecting TSG2nO1, TSG2nO3, and TSG2nO5 outputs by TSnPAT0.	TSnCMP11, TSnCMP12: Selecting TSG2nO2, TSG2nO4, and TSG2nO6 outputs by TSnPAT1.	See TSnCMP1W to TSnCMP11W.

Table 15-37 Compare Register Functions in Each Mode (3/4)

Operating Mode	TSnDCMP0W	TSnDCMP2W	TSnCMPU	TSnCMPV
PWM mode	Setting diagnostic output or A/D conversion trigger timing	Setting diagnostic output or A/D conversion trigger timing	-	-
HT-PWM mode	Setting diagnostic output or A/D conversion trigger timing	Setting diagnostic output or A/D conversion trigger timing	The TSnCMPU set value is used as the TSnCMP1W (TSnCMP1, TSnCMP2) set value.	The TSnCMPV set value is used as the TSnCMP5W (TSnCMP5, TSnCMP6) set value.
SP-PWM mode	Setting diagnostic output or A/D conversion trigger timing	Setting diagnostic output or A/D conversion trigger timing	-	-
120-DC mode	Setting diagnostic output or A/D conversion trigger timing	Setting diagnostic output or A/D conversion trigger timing	-	-

Table 15-37 Compare Register Functions in Each Mode (4/4)

Operating Mode	TSnCMPW	TSnUPW	TSnVPW	TSnWPW
PWM mode	-	-	-	-
HT-PWM mode	The TSnCMPW set value is used as the TSnCMP9W (TSnCMP9, TSnCMP10) set value.	-	-	-
SP-PWM mode	-	The sum of the TSnUPW set value and the TSnCMP2 set value is used as the TSnCMP1 set value.	The sum of the TSnVPW set value and the TSnCMP6 set value is used as the TSnCMP5 set value.	The sum of the TSnWPW set value and the TSnCMP10 set value is used as the TSnCMP9 set value.
120-DC mode	-	-	-	-

15.5.3 Compare Register Rewrite Operation

The following compare registers are rewritten by reload (TSnCTL3.TSnRMC = 0) or anytime rewrite (TSnCTL3.TSnRMC = 1).

- TSnCMP0
- TSnCMP1 to TSnCMP12 (TSnCMP1W, TSnCMP3W, TSnCMP5W, TSnCMP7W, TSnCMP9W, TSnCMP11W)
- TSnPAT0W, TSnPAT1W
- TSnDTC0W, TSnDTC1W
- TSnDCMP0W, TSnDCMP2
- TSnCTL2, TSnCTL4
- TSnIOC3

Anytime rewrite mode In this mode, the compare registers are rewritten independently. Whenever a value is written to the compare register, the written value is reflected immediately.

Caution In HT-PWM mode and in anytime rewrite mode, if rewrite is performed again before a transfer to the buffer register is completed, the written value is not reflected immediately.
If the rewrite is performed while the 16-bit counter is counting up, the value is reflected at the next peak timing of the 16-bit sub-counter. If the rewrite is performed while the 16-bit counter is counting down, the value is reflected at the next valley timing of the 16-bit sub-counter.

Reload mode (simultaneous rewrite function) Writing to TSnCMP1 (TSnCMP1W, TSnCMPU, TSnUPW) enables reload (sets the reload request flag (TSnSTR0.TSnRSF)), and the values of all the pertinent registers are updated simultaneously at the next reload timing (reload).

The reload timing is the peak or valley timing of the 16-bit counter when the TSnTRG0.TSnTS bit is changed from 0 to 1. Reloading is controlled by TSnCTL4.TSnPRE and TSnVRE.

Writing to any register other than TSnCMP1 (TSnCMP1W, TSnCMPU, TSnUPW) does not enable reloading.

Do not write to the registers to be reloaded until the next reload timing after reloading is enabled by writing to TSnCMP1 (TSnCMP1W, TSnCMPU, TSnUPW). The pertinent registers should be rewritten when the reload request flag (TSnSTR0.TSnRSF) is 0.

Rewriting registers to be reloaded by DMA transfer Some of the registers to be reloaded can be rewritten by DMA transfer. DMA transfer is performed as follows.

Table 15-38 Example of DMA Transfer Order of Registers to be Reloaded

Address	Register Name	DMA Transfer Order (Example)
<TSG2n_base1> + 040 _H	TSnCMP1W	↑
<TSG2n_base1> + 044 _H	TSnCMP5W	
<TSG2n_base1> + 048 _H	TSnCMP9W	
<TSG2n_base1> + 04C _H	TSnCMP3W	
<TSG2n_base1> + 050 _H	TSnCMP7W	
<TSG2n_base1> + 054 _H	TSnCMP11W	
<TSG2n_base1> + 058 _H	TSnCMP0	
<TSG2n_base1> + 05C _H	TSnDCMP0W	
<TSG2n_base1> + 060 _H	TSnDCMP2	
<TSG2n_base1> + 064 _H	TSnPAT0W	
<TSG2n_base1> + 068 _H	TSnPAT1W	
<TSG2n_base1> + 06C _H	TSnDTC0W	
<TSG2n_base1> + 070 _H	TSnDTC1W	

Table 15-39 Duty Setting in HT-PWM Mode

Address	Register Name	DMA Transfer Order (Example)
<TSG2n_base1> + 0B0 _H	TSnCMPU	↑
<TSG2n_base1> + 0B4 _H	TSnCMPV	
<TSG2n_base1> + 0B8 _H	TSnCMPW	

Table 15-40 Active Width Setting in SP-PWM Mode

Address	Register Name	DMA Transfer Order (Example)
<TSG2n_base1> + 0BC _H	TSnUPW	↑
<TSG2n_base1> + 0C0 _H	TSnVPW	
<TSG2n_base1> + 0C4 _H	TSnWPW	

Note 1. TSnCTL2, TSnCTL4, and TSnIOC3 should be rewritten individually.

Note 2. Since writing to TSnCMP1W (including TSnCMP1, TSnCMPU, and TSnUPW) enables reloading, it should be rewritten after all the other registers to be reloaded have been rewritten (ready to be reloaded).

(1) Example of Operation in Anytime Rewrite Mode

In this mode, the values written to the compare registers (TSnCMP1 to TSnCMP12) are transferred to the internal buffer registers immediately, and are compared with the counter value.

The values are transferred to the internal compare buffer registers one clock cycle (PCLK) after being written to the compare registers (TSnCMP1 to TSnCMP12).

The transfer timing of the TSnCMP0 is the peak or valley timing (only in HT-PWM mode) of the 16-bit counter after being written to the compare registers, or at the match timing of the TSnCMP0 value with the 16-bit counter value (in any mode other than HT-PWM mode).

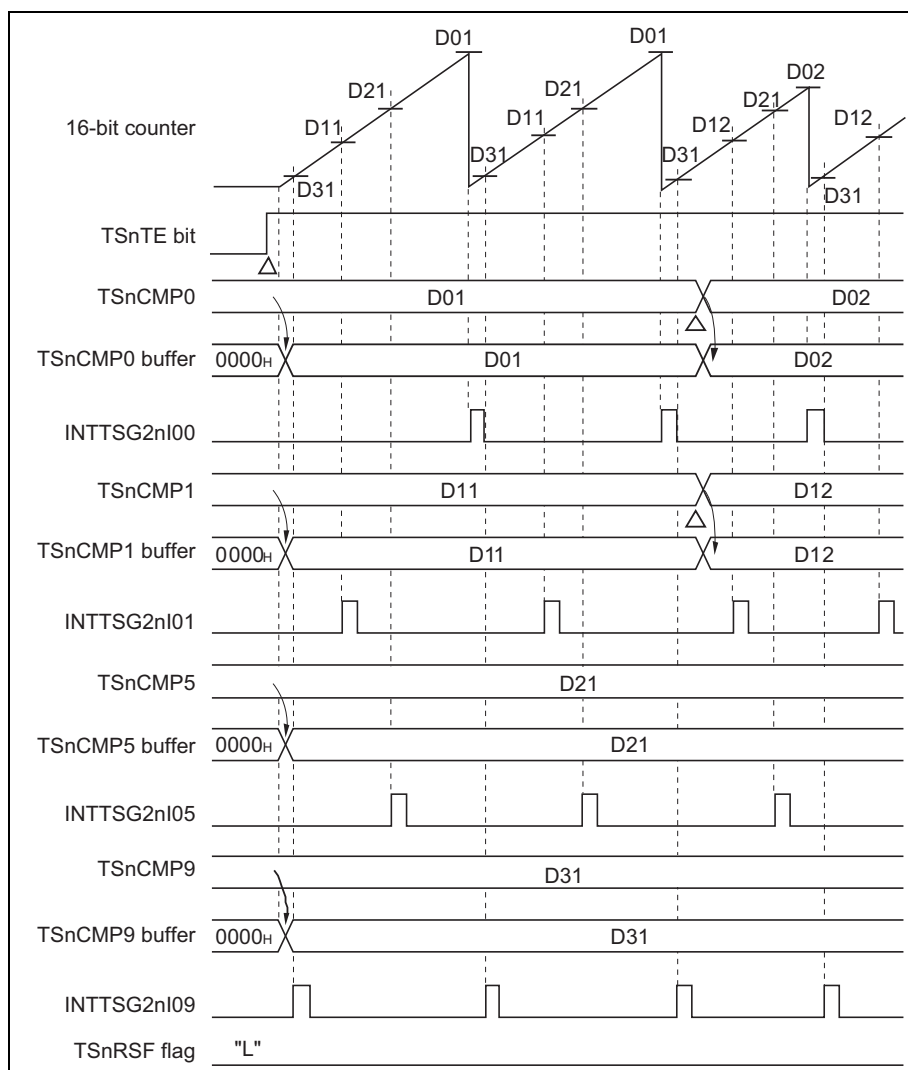

Figure 15-2 Anytime Rewrite Timing (Example in PWM Mode)

- Note 1. D01, D02: TSnCMP0 setting value (0000_H to FFFF_H)
 D11, D12: TSnCMP1 setting value (0000_H to FFFF_H)
 D21: TSnCMP5 setting value (0000_H to FFFF_H)
 D31: TSnCMP9 setting value (0000_H to FFFF_H)

- Note 2. Δ: Write access

(a) Data Reflection on PWM at Anytime Rewrite in HT-PWM Mode

In HT-PWM mode, the following output control is performed depending on the anytime rewrite timing of the compare registers.

- If anytime rewrite is performed after the inverse phase is cleared while the 16-bit counter is counting up (the 16-bit sub-counter is counting up), the positive phase is set if the rewritten value is $TSnCMPm < TSnSBC$. The inverse phase is set if the rewritten value is $TSnCMPm > TSnCNT$. (The dead time is inserted after clearance of the positive phase and inverse phase.)
- If anytime rewrite is performed after the positive phase is set while the 16-bit counter is counting up (the 16-bit sub-counter is counting up), the positive phase is cleared if the rewritten value is $TSnCMPm > TSnSBC$. The positive phase is cleared and the inverse phase is set if the rewritten value is $TSnCMPm > TSnCNT$. (The dead time is inserted after clearance of the positive phase and inverse phase.)
- If anytime rewrite is performed before the inverse phase is cleared while the 16-bit counter is counting up (the 16-bit sub-counter is counting up), the inverse phase is cleared if the rewritten value is $TSnCMPm < TSnCNT$. The inverse phase is cleared and the positive phase is set if the rewritten value is $TSnCMPm < TSnSBC$. (The dead time is inserted after clearance of the positive phase and inverse phase.)
- If anytime rewrite is performed after the positive phase is cleared while the 16-bit counter is counting up (the 16-bit sub-counter is counting down), the inverse phase is set if the rewritten value is $TSnCMPm > TSnCNT$. (The dead time is inserted after clearance of the positive phase.)
- If anytime rewrite is performed before the positive phase is cleared while the 16-bit counter is counting up (the 16-bit sub-counter is counting down), the positive phase is cleared if the rewritten value is $TSnCMPm > TSnSBC$. The positive phase is cleared and the inverse phase is set if the rewritten value is $TSnCMPm > TSnCNT$. (The dead time is inserted after clearance of the positive phase and inverse phase.)
- If anytime rewrite is performed after the positive phase is set while the 16-bit counter is counting up (the 16-bit sub-counter is counting up), the positive phase is cleared if the rewritten value is $TSnCMPm > TSnSBC$. The positive phase is cleared and the inverse phase is set if the rewritten value is $TSnCMPm > TSnCNT$. (The dead time is inserted after clearance of the positive phase and inverse phase.)
- If anytime rewrite is performed after the positive phase is set while the 16-bit counter is counting down (the 16-bit sub-counter is counting up), the positive phase is cleared if the rewritten value is $TSnCMPm > TSnSBC$. (The dead time is inserted after clearance of the positive phase.)
- If anytime rewrite is performed after the positive phase is set while the 16-bit counter is counting down (the 16-bit sub-counter is counting up), the positive phase is cleared if the rewritten value is $TSnCMPm > TSnCNT$. The positive phase is cleared and the inverse phase is set if the rewritten value is $TSnCMPm > TSnSBC$. (The dead time is inserted after clearance of the positive phase.)

(2) Example of Operation in Reload Mode (Simultaneous Rewrite Function)

The rewritten values of the registers to be reloaded (TSnCMP0 to TSnCMP12, TSnCTL2, TSnCTL3, TSnIOC3, TSnPAT0W, TSnPAT1W, TSnDTC0W, TSnDTC1W, TSnDCMP0W, and TSnDCMP2) can be transferred to the corresponding buffer registers simultaneously at the reload timing.

The registers should be rewritten when the pertinent reload request flag (TSnSTR0.TSnRSF) is 0.

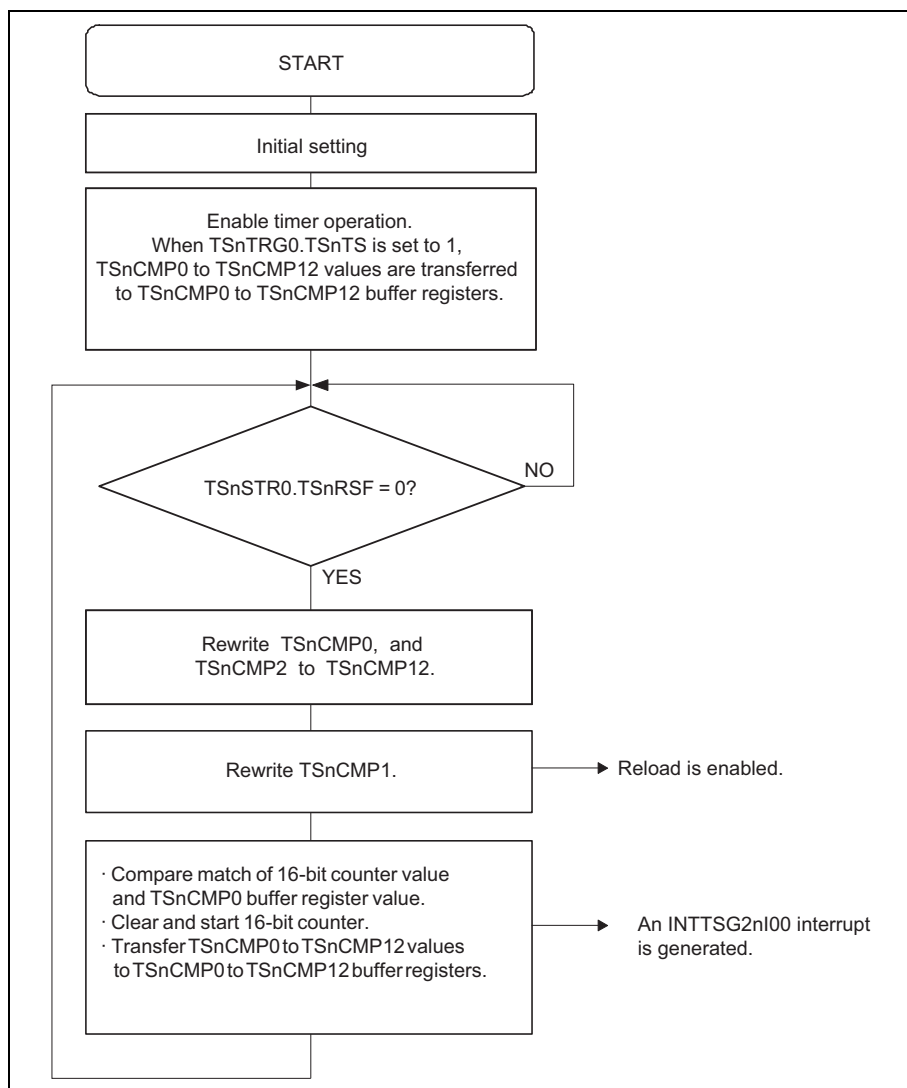

Figure 15-3 Basic Operation Flow in Reload Mode (Simultaneous Rewrite Function) (Example of PWM Mode)

Caution Writing to TSnCMP1 also enables reloading. Therefore, TSnCMP1 should be rewritten after TSnCMP0 and TSnCMP2 to TSnCMP12 registers have been rewritten.

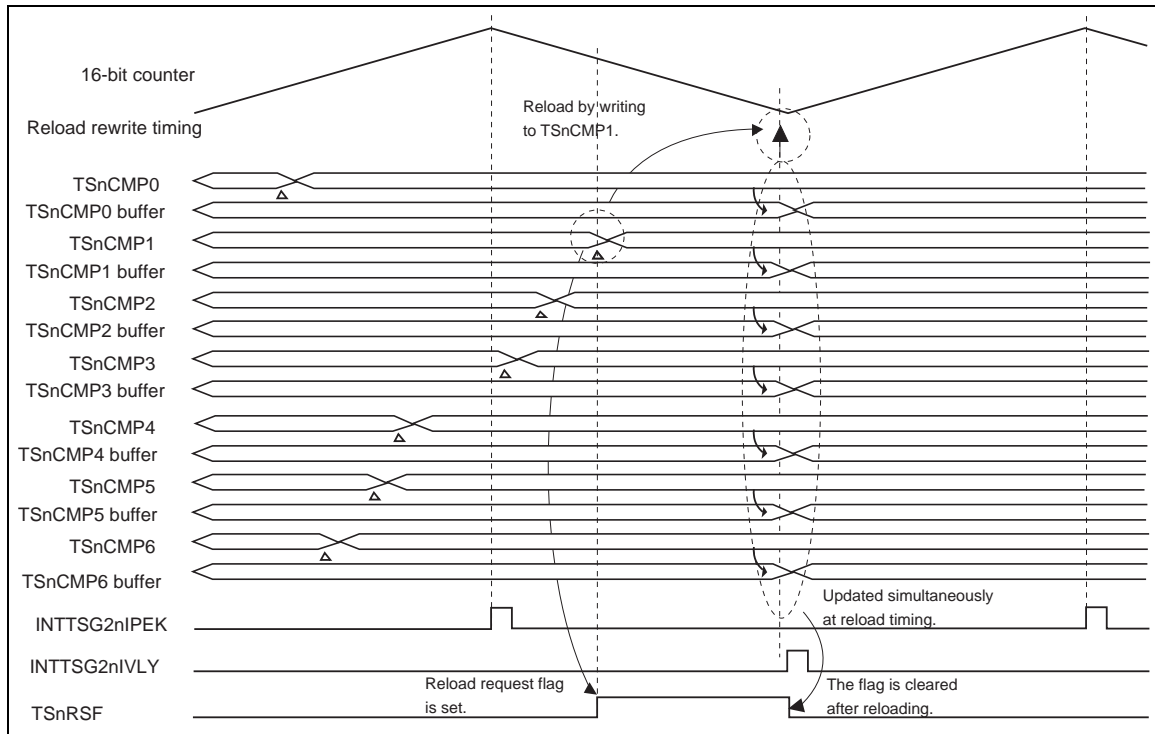

Figure 15-4 Simultaneous Rewrite Timing (1/2) (Example of HT-PWM Mode)

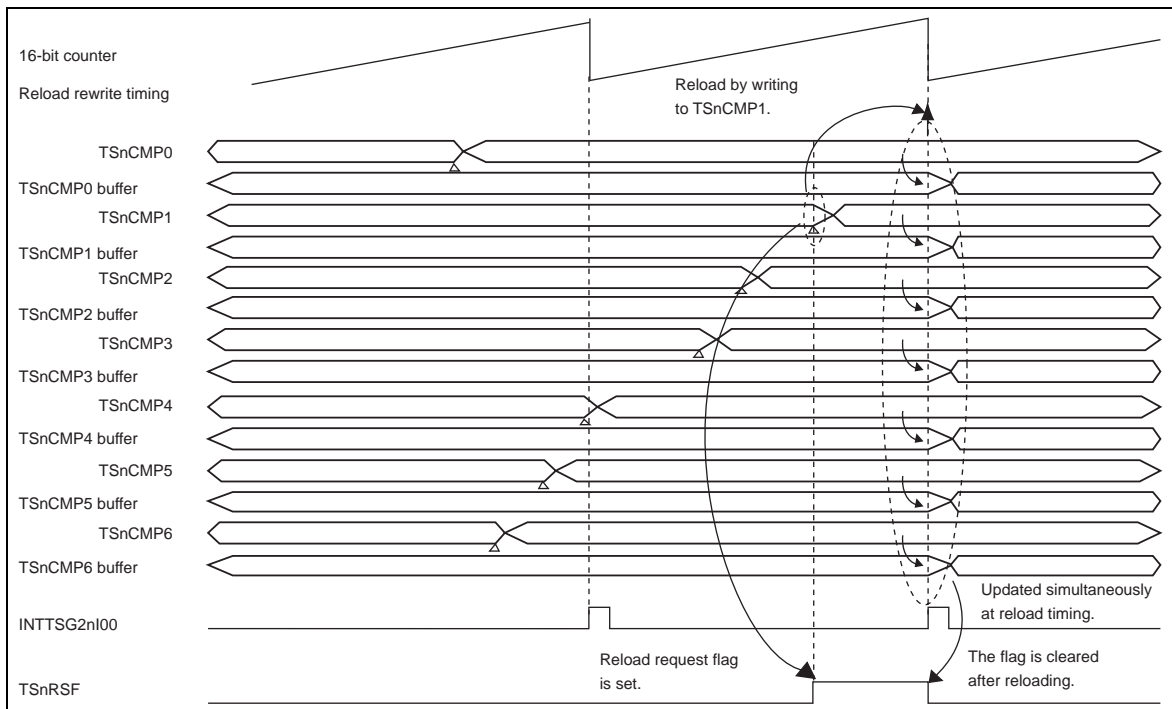

Figure 15-4 Simultaneous Rewrite Timing (2/2) (Example of PWM Mode)

(a) Reload Rewrite Setting Example in Each Mode

Reloading conditions and setting examples are shown in Table 15-41 and Table 15-42.

Table 15-41 List of Reload Settings (when TSnCTL3.TSnRIA = 0)

Mode	TSnCTL4. TSnPRE	TSnCTL4. TSnVRE	TSnCTL4. TSnPIE	TSnCTL4. TSnVIE	TSnCTL4. TSnRCC4 to TSnRCC0	Reload
PWM mode	0	0/1	0/1	0/1	Any value	Setting prohibited
SP-PWM mode	1	0	0/1	0/1	Any value	When INTTSG2nI00 is generated.
120-DC mode	1	1	0/1	0/1	Any value	When INTTSG2nI00 is generated.
HT-PWM mode	0	0	0/1	0/1	Any value	Setting prohibited
	0	1	0/1	0/1	Any value	When INTTSG2nIVLY is generated.
	1	0	0/1	0/1	Any value	When INTTSG2nIPEK is generated.
	1	1	0/1	0/1	Any value	When INTTSG2nIPEK or INTTSG2nIVLY is generated.

Table 15-42 List of Reload Settings (when TSnCTL3.TSnRIA = 1)

Mode	TSnCTL4. TSnPRE	TSnCTL4. TSnVRE	TSnCTL4. TSnPIE	TSnCTL4. TSnVIE	TSnCTL4. TSnRCC4- TSnRCC0	Reload
PWM mode	0	0/1	0/1	0/1	Any value	Setting prohibited
SP-PWM mode	1	0	0	0/1	Any value	Setting prohibited
120-DC mode	1	0	1	0/1	Any value	When INTTSG2nI00 is generated.
	1	1	0	0/1	Any value	Setting prohibited
	1	1	1	0/1	Any value	When INTTSG2nI00 is generated.
HT-PWM mode	0	0	0/1	0/1	Any value	Setting prohibited
	0	1	0	0	Any value	Setting prohibited
	0	1	0	1	Any value	When INTTSG2nIVLY is generated.
	0	1	1	0	Any value	Setting prohibited
	0	1	1	1	Any value	When INTTSG2nIVLY is generated.
	1	0	0	0/1	Any value	Setting prohibited
	1	0	1	0/1	Any value	When INTTSG2nIPEK is generated.
	1	1	0	0	Any value	Setting prohibited
	1	1	0	1	Any value	When INTTSG2nIVLY is generated.
	1	1	1	0	Any value	When INTTSG2nIPEK is generated.
	1	1	1	1	Any value	When INTTSG2nIPEK or INTTSG2nIVLY is generated.

15.5.4 List of Outputs in Each Mode

(1) Timer Output in Each Mode

The list of timer outputs (TSG2nO0 to TSG2nO7 pins) in each mode is shown in Table 15-43.

Table 15-43 List of Timer Outputs in Each Mode (1/3)

Operating Mode	TSG2nO0 Pin	TSG2nO1 Pin	TSG2nO2 Pin
PWM mode	- (Fixed to low.)	Outputs a PWM signal by compare match of TSnCMP1W (TSnCMP1 and TSnCMP2).	Outputs a PWM signal by compare match of TSnCMP3W (TSnCMP3 and TSnCMP4).
HT-PWM mode	Outputs the status indicating whether the 16-bit counter or 16-bit sub-counter is incremented or decremented.	Outputs a positive phase PWM signal (with dead time) by compare match of TSnCMP1W (TSnCMP1 and TSnCMP2).	Outputs an inverse phase PWM signal (with dead time) to TSG2nO1 pin.
SP-PWM mode	- (Fixed to low.)	Outputs a positive phase PWM signal (with dead time) by compare match of TSnCMP1W (TSnCMP1 and TSnCMP2).	Outputs an inverse phase PWM signal (with dead time) to TSG2nO1 pin.
120-DC mode	- (Fixed to low.)	Outputs a PWM signal by TSnCMP1W (TSnCMP1 and TSnCMP2), TSnCMP5W (TSnCMP5 and TSnCMP6), and TSnCMP9W (TSnCMP9 and TSnCMP10).	Outputs a PWM signal by TSnCMP3W (TSnCMP3 and TSnCMP4), TSnCMP7W (TSnCMP7 and TSnCMP8), and TSnCMP11W (TSnCMP11 and TSnCMP12).

Table 15-43 List of Timer Outputs in Each Mode (2/3)

Operating Mode	TSG2nO3 Pin	TSG2nO4 Pin	TSG2nO5 Pin
PWM mode	Outputs a PWM signal by compare match of TSnCMP5W (TSnCMP5 and TSnCMP6).	Outputs a PWM signal by compare match of TSnCMP7W (TSnCMP7 and TSnCMP8).	Outputs a PWM signal by compare match of TSnCMP9W (TSnCMP9 and TSnCMP10).
HT-PWM mode	Outputs a positive phase PWM signal (with dead time) by compare match of TSnCMP5W (TSnCMP5 and TSnCMP6).	Outputs an inverse phase PWM signal (with dead time) to TSG2nO3 pin.	Outputs a positive phase PWM signal (with dead time) by compare match of TSnCMP9W (TSnCMP9 and TSnCMP10).
SP-PWM mode	Outputs a positive phase PWM signal (with dead time) by compare match of TSnCMP5W (TSnCMP5, TSnCMP6)	Outputs an inverse phase PWM signal (with dead time) to TSG2nO3 pin.	Outputs a positive phase PWM signal (with dead time) by compare match of TSnCMP9W (TSnCMP9 and TSnCMP10).
120-DC mode	Outputs a PWM signal by TSnCMP1W (TSnCMP1 and TSnCMP2), TSnCMP5W (TSnCMP5 and TSnCMP6), and TSnCMP9W (TSnCMP9 and TSnCMP10).	Outputs a PWM signal by TSnCMP3W (TSnCMP3 and TSnCMP4), TSnCMP7W (TSnCMP7 and TSnCMP8), and TSnCMP11W (TSnCMP11 and TSnCMP12).	Outputs a PWM signal by TSnCMP1W (TSnCMP1 and TSnCMP2), TSnCMP5W (TSnCMP5 and TSnCMP6), and TSnCMP9W (TSnCMP9 and TSnCMP10).

Table 15-43 List of Timer Outputs in Each Mode (3/3)

Operating Mode	TSG2nO6 Pin	TSG2nO7 Pin
PWM mode	Outputs a PWM signal by compare match of TSnCMP11W (TSnCMP11 and TSnCMP12)	Outputs a diagnostic signal or A/D conversion trigger.
HT-PWM mode	Outputs an inverse phase PWM signal (with dead time) to TSG2nO5 pin.	Outputs a diagnostic signal or A/D conversion trigger.
SP-PWM mode	Outputs an inverse phase PWM signal (with dead time) to TSG2nO5 pin.	Outputs a diagnostic signal or A/D conversion trigger*.
120-DC mode	Outputs a PWM signal by TSnCMP3W (TSnCMP3 and TSnCMP4), TSnCMP7W (TSnCMP7 and TSnCMP8), and TSnCMP11W (TSnCMP11 and TSnCMP12).	Outputs a diagnostic signal or A/D conversion trigger*.

Note * For TSG2nO7, see Section 15.5.4 (1) (a), TSG2nO7 Pin Output Control.

(a) TSG2nO7 Pin Output Control

The TSG2nO7 pin can output a pulse of A/D conversion trigger (TSnIOC1.TSnTGS = 0) or diagnostic output (TSnIOC1.TSnTGS = 1). When outputting a pulse of A/D conversion trigger, the TSG2nO7 pin is activated at the rising edge of the TSnADTRG0 signal, and inactivated at the rising edge of the TSnADTRG1 signal. When the TSnADTRG0 signal is detected while the TSG2nO7 pin is active, the TSG2nO7 pin remains active. When the TSnADTRG1 signal is detected while the TSG2nO7 pin is inactive, the TSG2nO7 pin remains inactive. If TSnADTRG0 and TSnADTRG1 signal triggers occur simultaneously, the TSG2nO7 pin is inactivated.

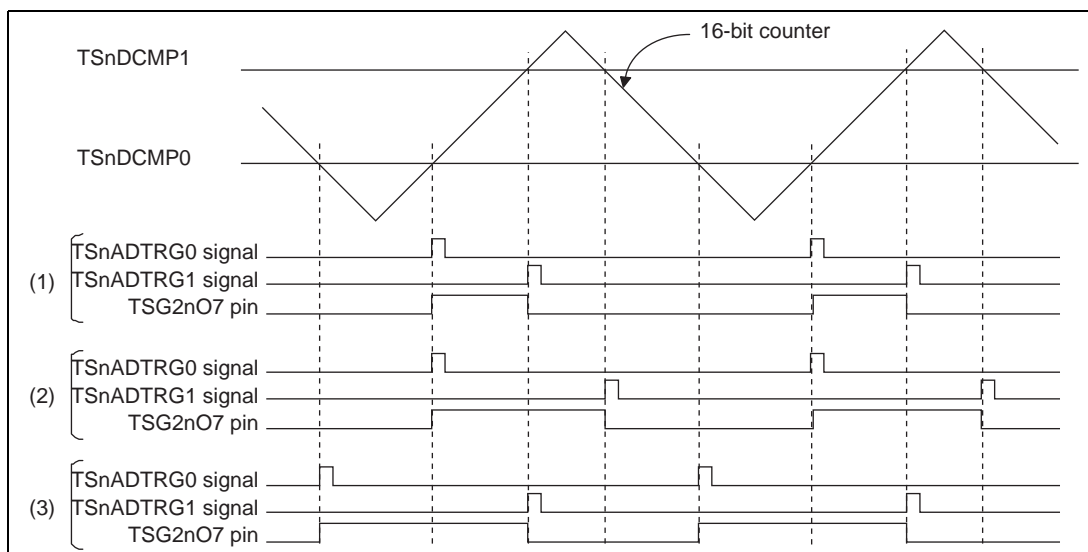

Figure 15-5 Example of A/D Trigger Output Timing of TSG2nO7 Pin (TSnIOC1.TSnTGS = 0)

- Note (1) When TSnDCMP0 < TSnDCMP1, TSnCTL5 = 0004_H, and TSnCTL6 = 0010_H
 (2) When TSnDCMP0 < TSnDCMP1, TSnCTL5 = 0004_H, and TSnCTL6 = 0020_H
 (3) When TSnDCMP0 < TSnDCMP1, TSnCTL5 = 0008_H, and TSnCTL6 = 0010_H
 For TSG2nO7, see Section 15.5.4 (1) (a), TSG2nO7 Pin Output Control.

The TSG2nO7 pin during diagnostic output outputs the active level with the output width specified by TSnCTL0.TSnDWD at the match timing of the TSnDCMP0 to TSnDCMP2 values with the 16-bit counter value. If another match of the TSnDCMP0 to TSnDCMP2 values with the 16-bit counter value occurs consecutively within the output width specified by TSnDWD causing their active level widths to be overlapped, the TSG2nO7 pin outputs a pulse within 16 clock cycles (PCLK).

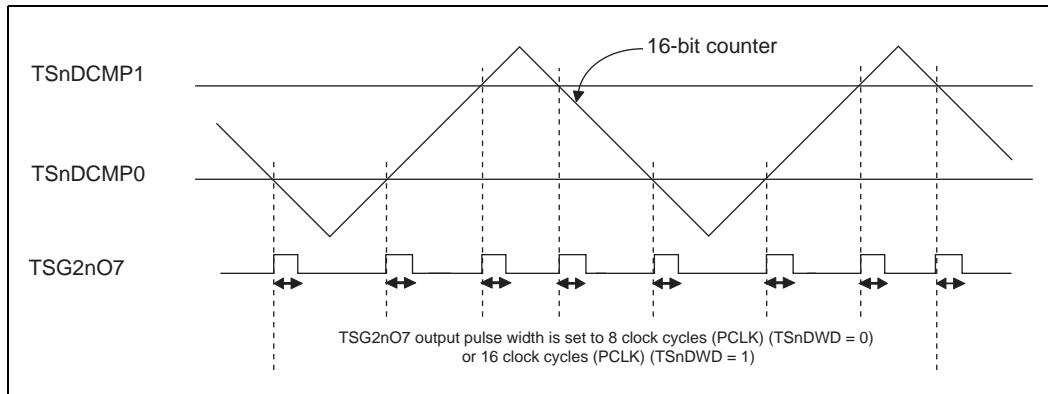

Figure 15-6 Example of TSG2nO7 Pin Diagnostic Pulse Output Timing (1)
(TSnIOC1.TSnTGS = 1)

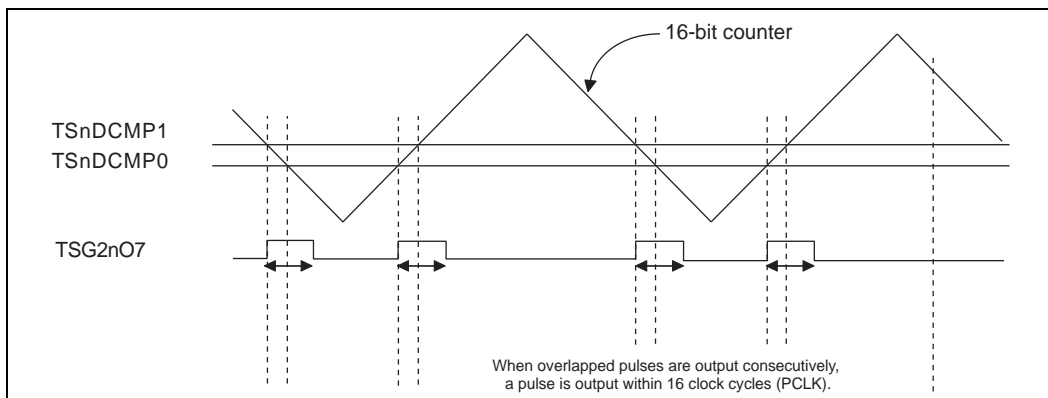

Figure 15-7 Example of TSG2nO7 Pin Diagnostic Pulse Output Timing (2)
(with Pulse Output Width Overlapped)

(2) Interrupts in Each Mode

A list of interrupts (INTTSG2nI00 to INTTSG2nI12, INTTSG2nIPEK, INTTSG2nIVLY, INTTSG2nIER, and INTTSG2nIWN) in each mode is shown in Table 15-44.

Table 15-44 List of Interrupts in Each Mode (1/5)

Operating Mode	INTTSG2nI00	INTTSG2nI01	INTTSG2nI02	INTTSG2nI03
PWM mode	TSnCMP0 compare match interrupt	TSnCMP1 compare match interrupt* ¹	TSnCMP2 compare match interrupt* ¹	TSnCMP3 compare match interrupt* ¹
HT-PWM mode	Period interrupt	TSnCMP1 compare match interrupt* ²	TSnCMP2 compare match interrupt* ²	—
SP-PWM mode	TSnCMP0 compare match interrupt	TSnCMP1 compare match interrupt* ¹	TSnCMP2 compare match interrupt* ¹	—
120-DC mode	TSnCMP0 compare match interrupt	TSnCMP1 compare match interrupt* ¹	TSnCMP2 compare match interrupt* ¹	TSnCMP3 compare match interrupt* ¹

Note 1. When $TSnCMP0 < TSnCMPm$, a compare match interrupt is not generated ($m = 1$ to 12).

Note 2. When $0000_H \leq TSnCMPm < TSnDTC0$, and $(TSnCMP0 + TSnDTC0) < TSnCMPm$, a compare match interrupt is not generated.

Table 15-44 List of Interrupts in Each Mode (2/5)

Operating Mode	INTTSG2nI04	INTTSG2nI05	INTTSG2nI06	INTTSG2nI07
PWM mode	TSnCMP4 compare match interrupt* ¹	TSnCMP5 compare match interrupt* ¹	TSnCMP6 compare match interrupt* ¹	TSnCMP7 compare match interrupt* ¹
HT-PWM mode	—	TSnCMP5 compare match interrupt* ²	TSnCMP6 compare match interrupt* ²	—
SP-PWM mode	—	TSnCMP5 compare match interrupt* ¹	TSnCMP6 compare match interrupt* ¹	—
120-DC mode	TSnCMP4 compare match interrupt* ¹	TSnCMP5 compare match interrupt* ¹	TSnCMP6 compare match interrupt* ¹	TSnCMP7 compare match interrupt* ¹

Note 1. When $TSnCMP0 < TSnCMPm$, a compare match interrupt is not generated ($m = 1$ to 12).

Note 2. When $0000_H \leq TSnCMPm < TSnDTC0$, and $(TSnCMP0 + TSnDTC0) < TSnCMPm$, a compare match interrupt is not generated.

Table 15-44 List of Interrupts in Each Mode (3/5)

Operating Mode	INTTSG2nI08	INTTSG2nI09	INTTSG2nI10	INTTSG2nI11
PWM mode	TSnCMP8 compare match interrupt ^{*1}	TSnCMP9 compare match interrupt ^{*1}	TSnCMP10 compare match interrupt ^{*1}	TSnCMP11 compare match interrupt ^{*1}
HT-PWM mode	—	TSnCMP9 compare match interrupt ^{*2}	TSnCMP10 compare match interrupt ^{*2}	—
SP-PWM mode	—	TSnCMP9 compare match interrupt ^{*1}	TSnCMP10 compare match interrupt ^{*1}	—
120-DC mode	TSnCMP8 compare match interrupt ^{*1}	TSnCMP9 compare match interrupt ^{*1}	TSnCMP10 compare match interrupt ^{*1}	TSnCMP11 compare match interrupt ^{*1}

Note 1. When $TSnCMP0 < TSnCMPm$, a compare match interrupt is not generated ($m = 1$ to 12).

Note 2. When $0000_H \leq TSnCMPm < TSnDTC0$, and $(TSnCMP0 + TSnDTC0) < TSnCMPm$, a compare match interrupt is not generated.

Table 15-44 List of Interrupts in Each Mode (4/5)

Operating Mode	INTTSG2nI12	INTTSG2nIPEK	INTTSG2nIVLY
PWM mode	TSnCMP12 compare match interrupt [*]	Peak interrupt at the same timing as INTTSG2nI00	—
HT-PWM mode	—	Peak interrupt	Valley interrupt
SP-PWM mode	—	Valley interrupt at the same timing as INTTSG2nI00	—
120-DC mode	TSnCMP12 compare match interrupt [*]	Peak interrupt at the same timing as INTTSG2nI00	—

Note * When $TSnCMP0 < TSnCMPm$, a compare match interrupt is not generated ($m = 1$ to 12).

Table 15-44 List of Interrupts in Each Mode (5/5)

Operating Mode	INTTSG2nIER	INTTSG2nIWN
PWM mode	Error interrupt	Warning interrupt
HT-PWM mode	Error interrupt	Warning interrupt
SP-PWM mode	Error interrupt	Warning interrupt
120-DC mode	Error interrupt	Warning interrupt

15.6 Match Interrupt

The TSG2n can generate interrupts such as a compare match interrupt (INTTSG2nIm), a peak interrupt (INTTSG2nIPEK), and a valley interrupt (INTTSG2nIVLY). For an error interrupt and warning interrupt (INTTSG2nIER and INTTSG2nIWN), see Section 15.10, Error/Warning Interrupt.

A period interrupt (INTTSG2nI00) is generated for each timer period. In HT-PWM mode, it is generated when the TSnDTC0 buffer register value matches with the 16-bit counter value. When the 16-bit counter performs sawtooth wave operation (PWM mode, SP-PWM mode, and 120-DC mode), it is generated after the 16-bit counter value has matched with the TSnCMP0 buffer register value.

A compare-match interrupt (INTTSG2nIm) is generated by a match of the TSnCMPm buffer register value with the 16-bit counter value depending on the compare register to be used in each operating mode (m = 01 to 12).

A peak interrupt (INTTSG2nIPEK) is generated in all the modes. In HT-PWM mode, it is generated when the 16-bit counter switches from incrementing to decrementing. When the 16-bit counter performs sawtooth wave operation (PWM mode, SP-PWM mode, and 120-DC mode), it is generated after the 16-bit counter value has matched with the TSnCMP0 buffer register value (the same timing as an INTTSG2nI00 interrupt).

A valley interrupt (INTTSG2nIVLY) is generated when the 16-bit counter switches from decrementing to incrementing in HT-PWM mode.

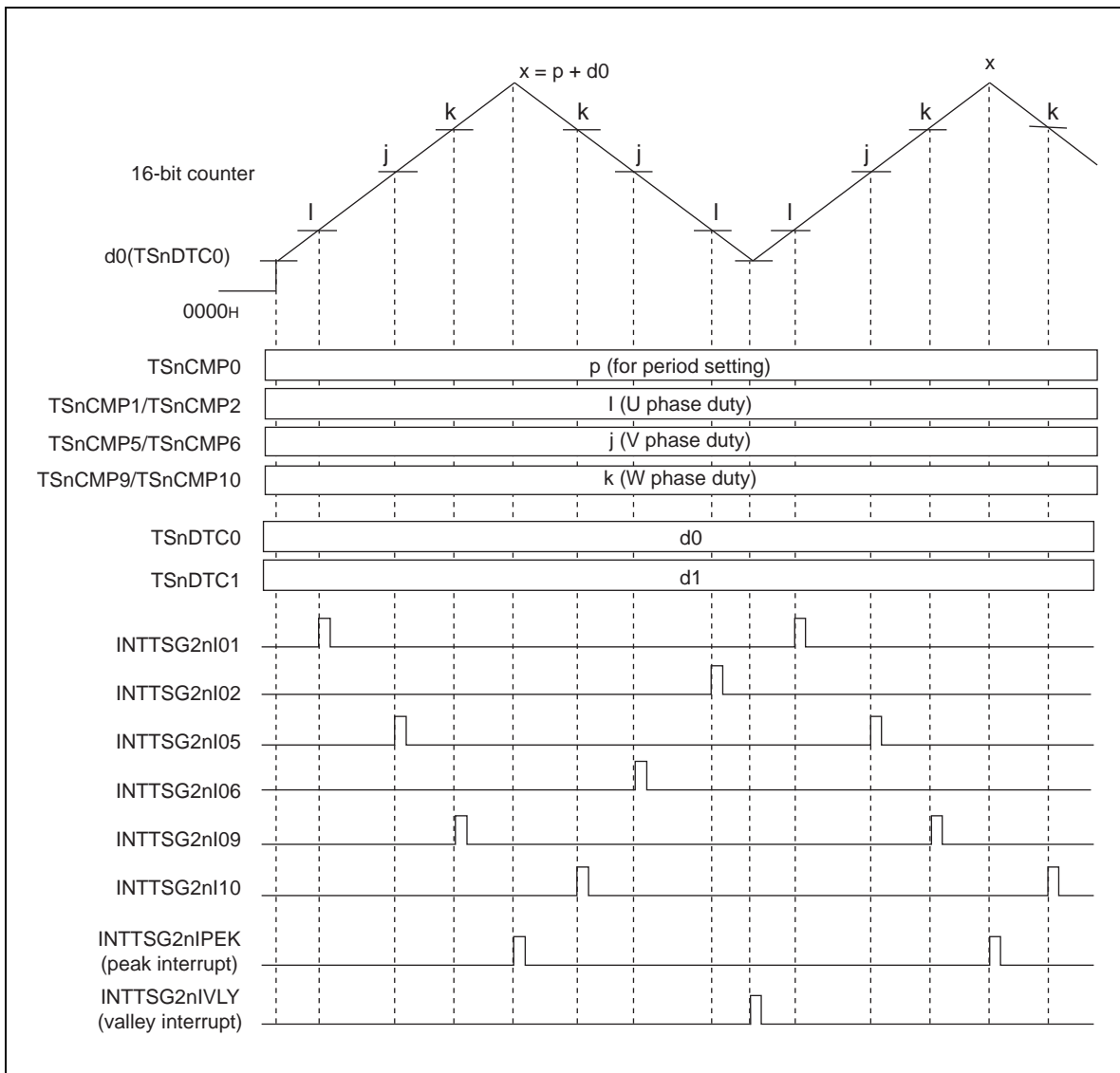

Figure 15-8 Interrupt Generation Example (1/2)
(Example of HT-PWM Mode)

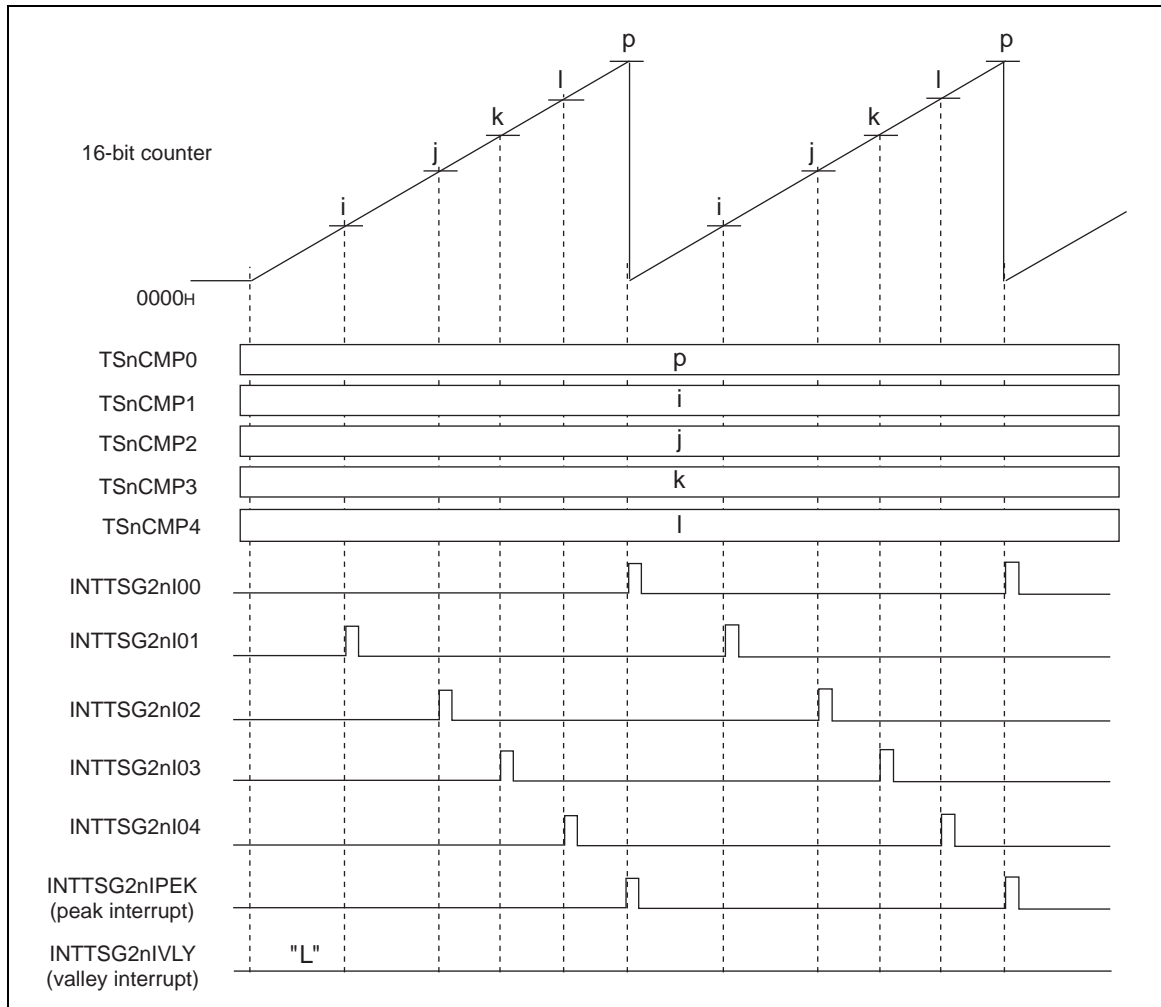

Figure 15-8 Interrupt Generation Example (2/2)
(Example of PWM Mode)

15.7 Flags

Table 15-45 List of Flags

No.	Flag Name	Symbol	Register	Operating Mode
(1)	Up count flag	TSnCUF	TSnSTR0	HT-PWM mode
		TSnSUF	TSnSTR0	
(2)	Positive phase and inverse phase simultaneous active state detection flag	TSnTBF0 to TSnTBF2	TSnSTR2	All operating modes
(3)	Reload request flag	TSnRSF	TSnSTR0	All operating modes
(4)	Noise detection flag	TSnNDF	TSnSTR2	All operating modes
(5)	Pattern order detection flag	TSnTSF	TSnSTR1	All operating modes
(6)	Pattern error detection flag	TSnPEF	TSnSTR2	All operating modes
(7)	Pattern reversal detection flag	TSnPRF	TSnSTR2	All operating modes
(8)	TSG2nPTSI2 to TSG2nPTSI0 pin abnormal toggle detection flag	TSnPTF	TSnSTR2	All operating modes
(9)	TSnOPCI0 and TSnOPCI1 signal simultaneous trigger detection flag	TSnTDF	TSnSTR2	All operating modes
(10)	Pattern phase difference detection flag	TSnPPF	TSnSTR2	All operating modes
(11)	Timer output pattern flag	TSnOPF0 to TSnOPF2	TSnSTR1	All operating modes
(12)	Pattern switch detection signal (internal signal)	TSnPTE	-	All operating modes

15.7.1 Up Count Flag (TSnCUF and TSnSUF)

Name Up count flag (TSnSTR0.TSnCUF and TSnSUF)

Description There are following two up count flags.

TSnCUF is an up/down count flag of the 16-bit counter.

TSnSUF is an up/down count flag of the 16-bit sub-counter.

For both TSnCUF and TSnSUF, 0 means increment, and 1 means decrement.

TSnCUF and TSnSUF can be used only in HT-PWM mode.

Example of operation

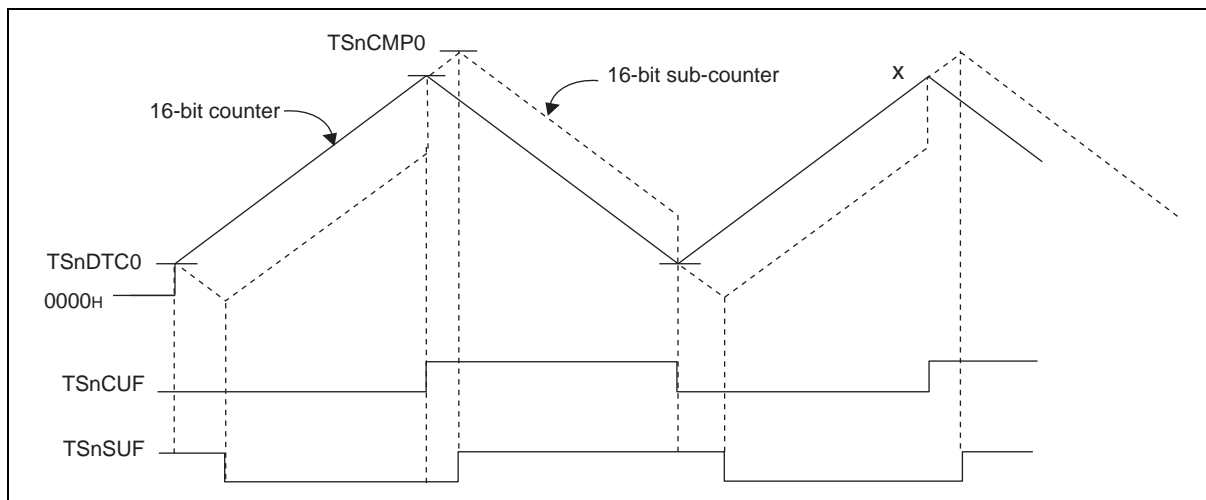

Figure 15-9 Example of Up Count Flag Operation

- Note 1. TSnCUF value is:
 0 (up count) when $\text{TSnDTC0} \leq \text{16-bit counter} \leq (\text{TSnCMP0} + \text{TSnDTC0} - 2)$
 1 (down count) when $(\text{TSnCMP0} + \text{TSnDTC0} - 2) \geq \text{16-bit counter} \geq \text{TSnDTC0} + 2$
- Note 2. TSnSUF value is:
 0 (up count) when $0 \leq \text{16-bit sub-counter} \leq (\text{TSnCMP0} + \text{TSnDTC0} + \text{TSnDTC1} - 2)$
 1 (down count) when $(\text{TSnCMP0} + \text{TSnDTC0} + \text{TSnDTC1}) \geq \text{16-bit sub-counter} \geq 2$

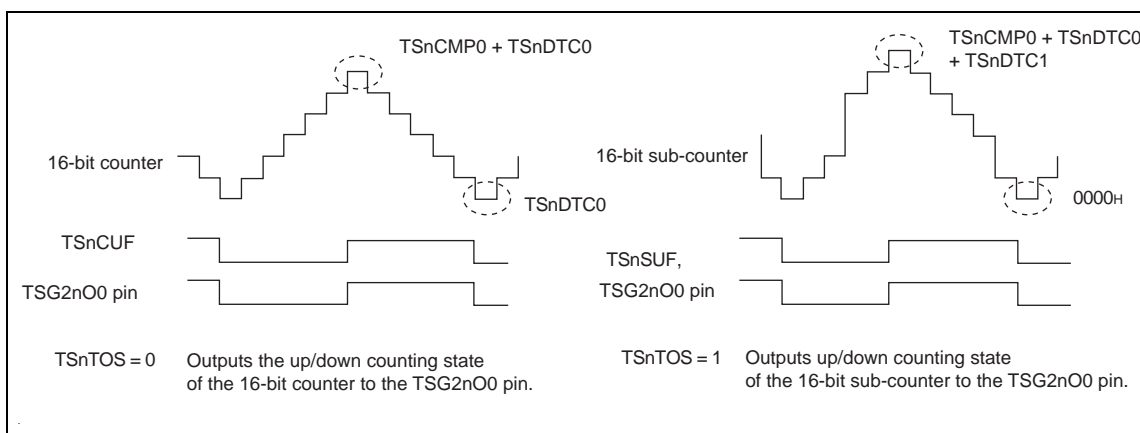

Figure 15-10 TSG2nO0 Pin Output depending onTSnIOC1.TSnTOS Setting

Operating mode TSnCUF and TSnSUF can be used only in HT-PWM mode.

15.7.2 Positive Phase and Inverse Phase Simultaneous Active State Detection Flag (TSnTBF0 to TSnTBF2)

Name Positive phase and inverse phase simultaneous active state detection flag (TSnSTR2.TSnTBF0 to TSnTBF2 flags)

Description When any of TSnCTL1.TSnTBA2 to TSnTBA0 is 1, TSnTBF0 to TSnTBF2 can detect the simultaneous active state of the positive phase and inverse phase of TSG2n.

When the simultaneous active state of the positive phase and inverse phase of the TSG2n is detected, the corresponding TSnTBF0 to TSnTBF2 flags are set to 1, and an error interrupt (INTTSG2nIER) is generated. The flags are cleared when 1 is written to TSnSTC.TSnTBR0 to TSnTBR2, respectively.

Example of operation

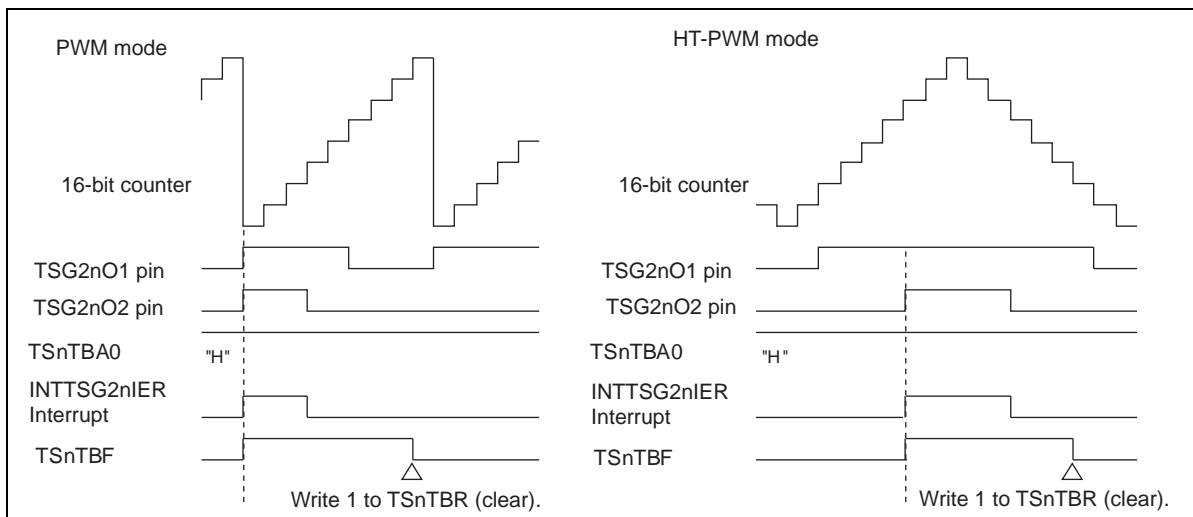

Figure 15-11 Example of Positive Phase and Inverse Phase Simultaneous Active State Detection Flag Operation

Operating mode TSnTBF0 to TSnTBF2 can be used in all operating modes.

Caution TSnTBF0 to TSnTBF2 are valid only when TSnCTL1.TSnTBA0 to TSnTBA2 = 1 and TSnSTR0.TSnTE = 1.

15.7.3 Reload Request Flag (TSnRSF)

Name Reload request flag (TSnSTR0.TSnRSF)

Description TSnRSF is set to 1 when a reload request is generated (when a value is written to TSnCMP1 (TSnCMP1W, TSnCMPU, TSnCPW)), and cleared to 0 when the value is transferred to all the buffer registers.

Example of operation

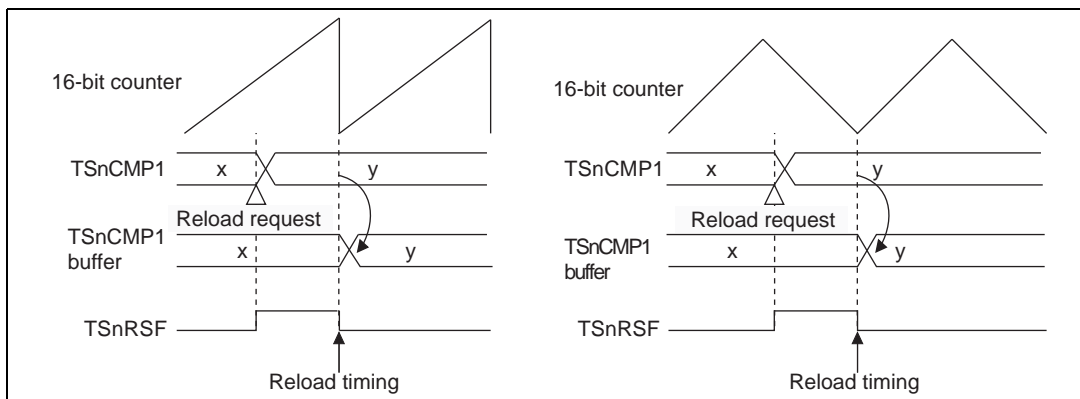

Figure 15-12 Example of Reload Request Flag Operation

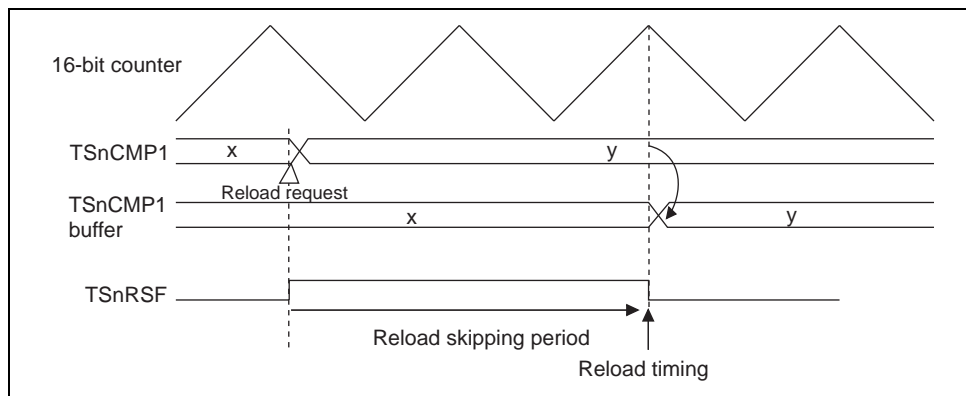

Figure 15-13 Reload Request Flag and Reload Skipping Period

Operating Mode TSnRSF can be used in all operating modes.

15.7.4 Noise Detection Flag (TSnNDF)

Name Noise detection flag (TSnSTR2.TSnNDF)

Description TSnNDF can detect that two or more pins of TSG2nPTS12 to TSG2nPTS10 have changed simultaneously (a noise is generated).

TSnNDF is set to 1 when two or more pins of TSG2nPTS12 to TSG2nPTS10 have changed simultaneously (a noise is generated), and a warning interrupt (INTTSG2nIWN) is generated. The TSnNDF flag is cleared to 0 when 1 is written to the TSnSTC.TSnNDR bit.

Example of operation

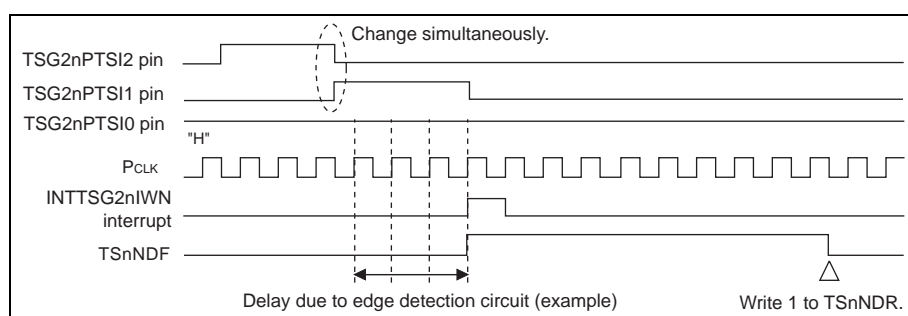

Figure 15-14 Example of Noise Detection Flag Operation

Operating mode TSnNDF can be used in all operating modes

Caution TSnNDF is valid only when TSnCTL1.TSnNDC = 1 and TSnSTR0.TSnTE = 1.

15.7.5 Pattern Order Detection Flag (TSnTSF)

Name Pattern order detection flag (TSnSTR1.TSnTSF)

Description TSnTSF can detect the order of patterns input to the TSG2nPTSI2 to TSG2nPTSI0 pins.

TSnTSF is set depending on the values input to the TSG2nPTSI2 to TSG2nPTSI0 pins as shown in the table below.

TSnTSF	Values input to TSG2nPTSI2 to TSG2nPTSI0 Pins
0	[1, 0, 1] → [1, 0, 0] → [1, 1, 0] → [0, 1, 0] → [0, 1, 1] → [0, 0, 1]
1	[1, 0, 1] ← [1, 0, 0] ← [1, 1, 0] ← [0, 1, 0] ← [0, 1, 1] ← [0, 0, 1]

Example of operation

(a) When Normal Input to TSG2nPTSI2 to TSG2nPTSI0 Pins is Detected

As shown in Figure 15-15, if the TSG2nPTSI2 to TSG2nPTSI0 pins change in the normal order, 0 or 1 is set according to the change order at the change timing.

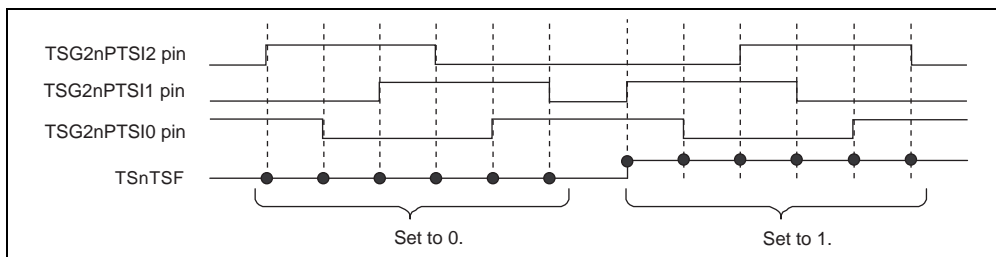

Figure 15-15 Example of Pattern Order Detection Flag Operation (Normal Operation)

(b) Detection of Input Pattern Order

Immediately after TSG2n starts operation, the rotation direction cannot be determined. Therefore, TSnTSF cannot detect the change (normal or reverse rotation) in the patterns input to the TSG2nPTSI2 to TSG2nPTSI0 pins. To enable detection of change immediately after the beginning of operation, TSnPSC should be set before operation starts (when TSnTE = 0, the TSnPSC value is reflected).

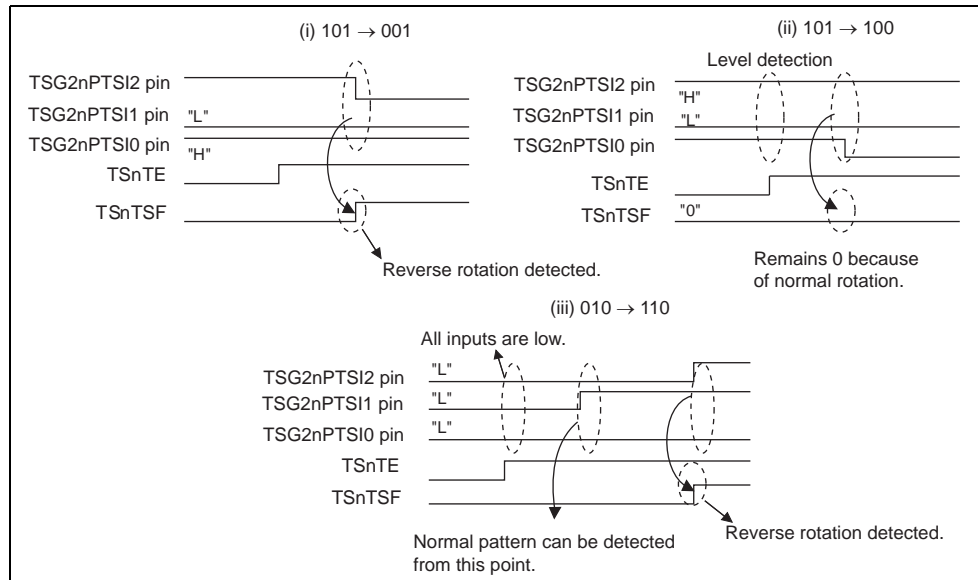

Figure 15-16 Example of Detecting Change (Normal/Reverse Rotation) in Pattern Input to TSG2nPTSI2 to TSG2nPTSI0 Pins

(c) When Abnormal Input to TSG2nPTSI2 to TSG2nPTSI0 Pins is Detected

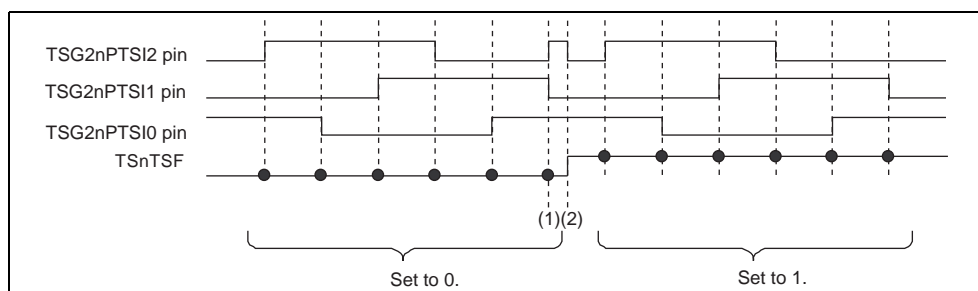

Figure 15-17 Example of Operation when Values Input to Two Pins of TSG2nPTSI2 to TSG2nPTSI0 Change (Abnormal Operation)

- (1) TSnTSF does not change at this point because it expects the input pattern change to {0, 1, 0} or {0, 0, 1} (if values of two pins change, TSnTSF does not change).
- (2) TSG2nPTSI2 to TSG2nPTSI0 pins are determined to have been changed from {1, 0, 1} to {0, 0, 1}, and TSnTSF is set to 1.

Operating Mode TSnTSF can be used in all operating modes.

15.7.6 Pattern Error Detection Flag (TSnPEF)

Name Pattern error detection flag (TSnSTR2.TSnPEF)

Description TSnPEF can detect that 000 or 111 is input to the TSG2nPTS12 to TSG2nPTS10 pins.

TSnPEF is set to 1 when the levels of the TSG2nPTS12 to TSG2nPTS10 pins are 111 or 000, and a warning interrupt (INTTSG2nIWN) is generated. TSnPEF is cleared to 0 when 1 is written to TSnSTC.TSnPER.

Example of operation

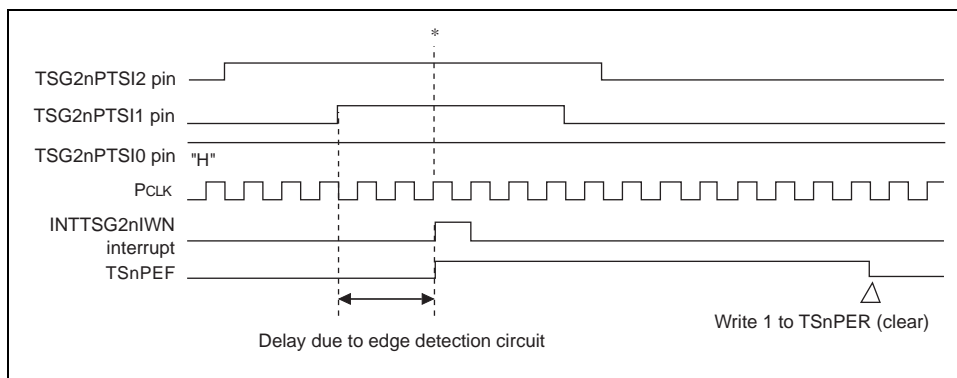

Figure 15-18 Example of Pattern Error Detection Flag Operation (TSG2nPTS12 to TSG2nPTS10 Pins = 111)

Note * 111 is detected.

Operating mode TSnPEF can be used in all operating modes.

Caution TSnPEF is valid only when TSnCTL1.TSnPEC = 1 and TSnSTR0.TSnTE = 1.

15.7.7 Pattern Reversal Detection Flag (TSnPRF)

Name Pattern reversal detection flag (TSnSTR2.TSnPRF)

Description TSnPRF can detect that the pattern change order of the TSG2nPTSI2 to TSG2nPTSI0 pins have been reversed.

TSnPRF is set to 1 when the pattern order detection flag (TSnTSF) changes, and a warning interrupt (INTTSG2nIWN) is generated. However, immediately after TSnSTR0.TSnTE is set to 1, TSnPRF is valid at the timing of the second and subsequent change in TSG2nPTSI2 to TSG2nPTSI0 pins.

TSnPRF is cleared to 0 when 1 is written to the TSnSTC.TSnPRR bit.

Example of operation

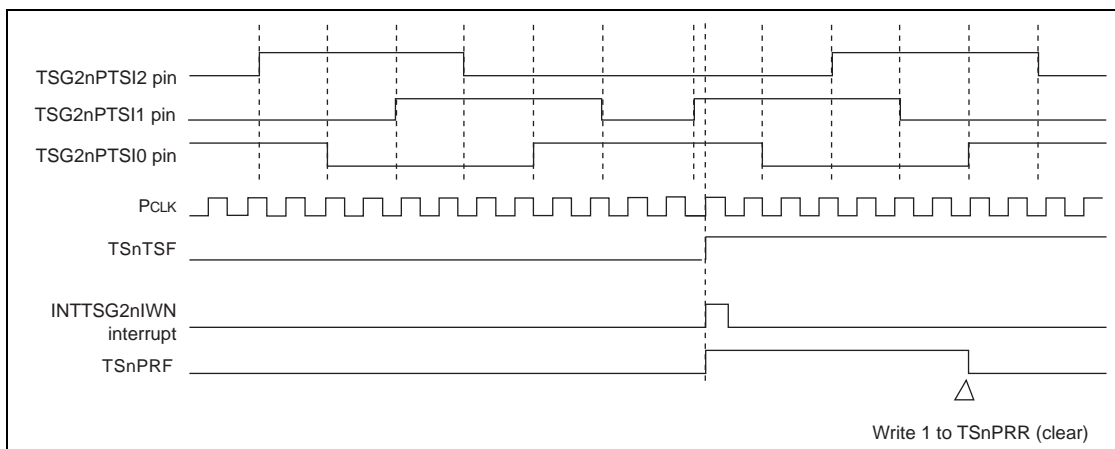

Figure 15-19 Example of Pattern Reversal Detection Flag Operation

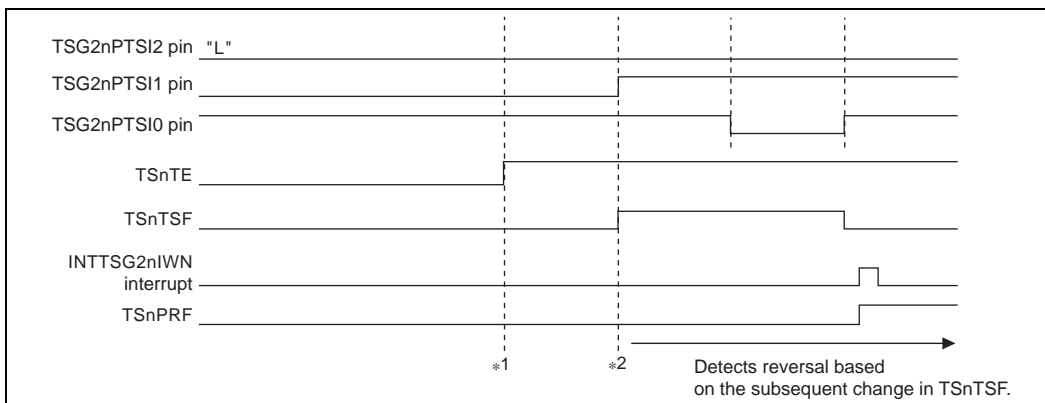

Figure 15-20 Example of Operation immediately after TSnTE Flag in TSnSTR0 is Set to 1

- Note 1. Operation starts.
- Note 2. If TSnTSF is set to 1 by the first change in the TSG2nPTSI2 to TSG2nPTSI0 pins immediately after TSnTE is set to 1, reversal is not detected.

Operating mode TSnPRF can be used in all operating modes.

Caution TSnPRF is valid only when TSnCTL1.TSnPRC = 1 and TSnSTR0.TSnTE = 1.

15.7.8 TSG2nPTSI2 to TSG2nPTSI0 Pin Abnormal Toggle Detection Flag (TSnPTF)

Name TSG2nPTSI2 to TSG2nPTSI0 pin abnormal toggle detection flag (TSnSTR2.TSnPTF)

Description TSnPTF can detect that the values of the TSG2nPTSI2 to TSG2nPTSI0 pins change three or more times during the TSnOPCI0 or TSnOPCI1 signal trigger.

TSnPTF is set to 1 when the third trigger of TSnOPCI0 or TSnOPCI1 signal occurs simultaneously with the change in TSG2nPTSI2 to TSG2nPTSI0, and a warning interrupt (INTTSG2nIWN) is generated.

TSnPTF is cleared to 0 when 1 is written to TSnSTC.TSnPTR.

Example of operation

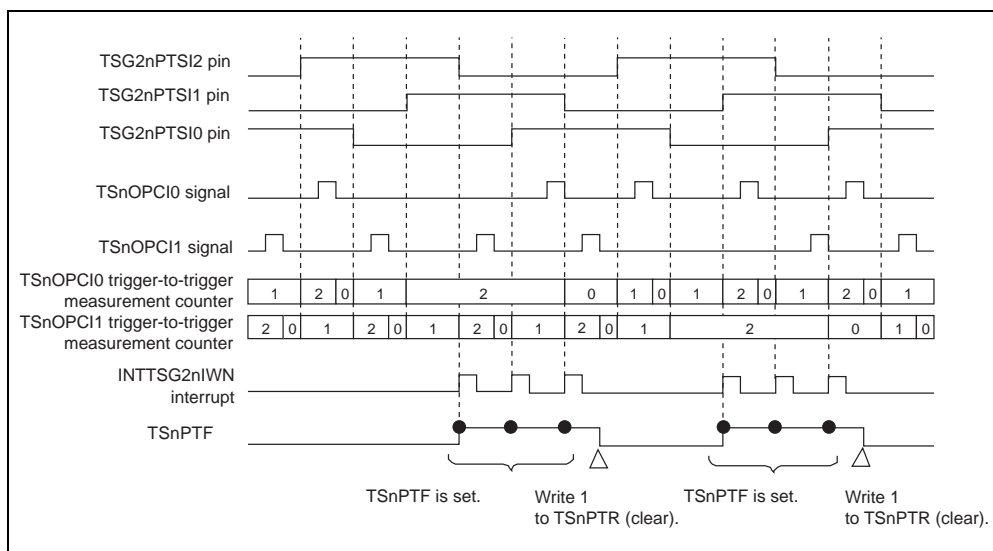

Figure 15-21 Example of TSG2nPTSI2 to TSG2nPTSI0 Pin Abnormal Toggle Detection Flag Operation

Operating mode TSnPTF can be used in all operating modes.

- Caution 1. TSnPTF is valid only when TSnCTL1.TSnPTC1 bit = 1 and TSnSTR0.TSnTE = 1.
- Caution 2. When TSnPTC0 bit = 1 and TSnPTC1 bit = 1, TSG2nO1 to TSG2nO6 pin output switch control is automatically switched to pattern switch method (TSnOPT0.TSnPOT bit = 0) if an abnormal toggle is detected.

15.7.9 TSnOPCI0 and TSnOPCI1 Signal Simultaneous Trigger Detection Flag (TSnTDF)

Name TSnOPCI0 and TSnOPCI1 signal simultaneous trigger detection flag (TSnSTR2.TSnTDF)

Description TSnTDF can detect that TSnOPCI0 and TSnOPCI1 signals are generated simultaneously.

TSnTDF is set to 1 when the TSnOPCI0 and TSnOPCI1 signals are generated simultaneously, and a warning interrupt (INTTSG2nIWN) is generated. TSnTDF is cleared to 0 when 1 is written to TSnSTC.TSnTDR.

Example of operation

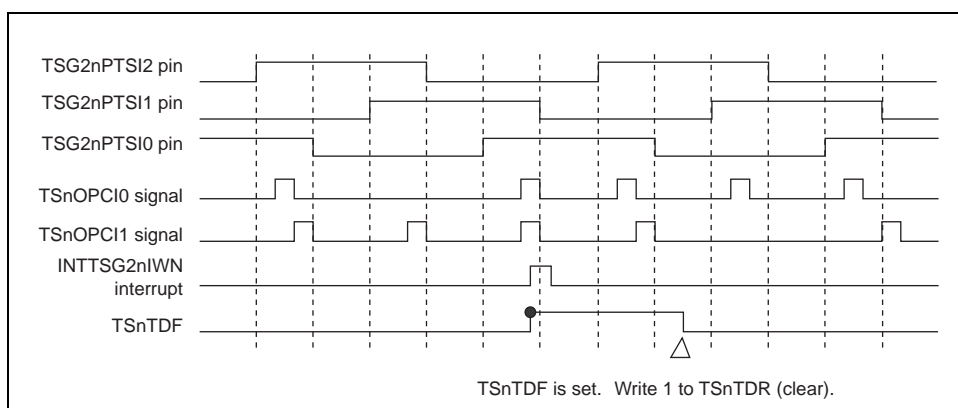

Figure 15-22 Operation of TSG2nPTS12 to TSG2nPTS10 Pin Abnormal Toggle Detection Flag Operation

Operating mode TSnTDF can be used in all operating modes.

Caution TSnTDF is valid only when TSnCTL1.TSnTDC = 1 and TSnSTR0.TSnTE = 1.

15.7.10 Pattern Phase Difference Detection Flag (TSnPPF)

Name Pattern phase difference detection flag (TSnSTR2.TSnPPF)

Description TSnPPF can detect the phase difference between the input pattern (TSG2nPTSI2 to TSG2nPTSI0 pins) and the output pattern (TSnSTR1.TSnOPF2 to TSnOPF0 flags).

TSnPPF is set to 1 when the pattern phase difference is detected when the TSnOPCI0 and TSnOPCI1 signal triggers are input, and a warning interrupt (INTTSG2nIWN) is generated. TSnPPF remains 1 until it is cleared to 0 when 1 is written to TSnSTC.TSnPPR by software. When the phase difference is detected, TSnPPF is set at each operation clock cycle (PCLK). TSnPPF should be cleared to 0 when no phase difference occurs.

Table 15-46 Correspondence between Normal Input Patterns and Output Patterns

TSG2nPTSI2 to TSG2nPTSI0 pins (input)	"1, 0, 1"	"1, 0, 0"	"1, 1, 0"	"0, 1, 0"	"0, 1, 1"	"0, 0, 1"
TSnOPF2 to TSnOPF0 flags (output)	"0, 0, 1"	"1, 0, 1"	"1, 0, 0"	"1, 1, 0"	"0, 1, 0"	"0, 1, 1"
	"1, 0, 1"	"1, 0, 0"	"1, 1, 0"	"0, 1, 0"	"0, 1, 1"	"0, 0, 1"
	"1, 0, 0"	"1, 1, 0"	"0, 1, 0"	"0, 1, 1"	"0, 0, 1"	"1, 0, 1"

Example of operation

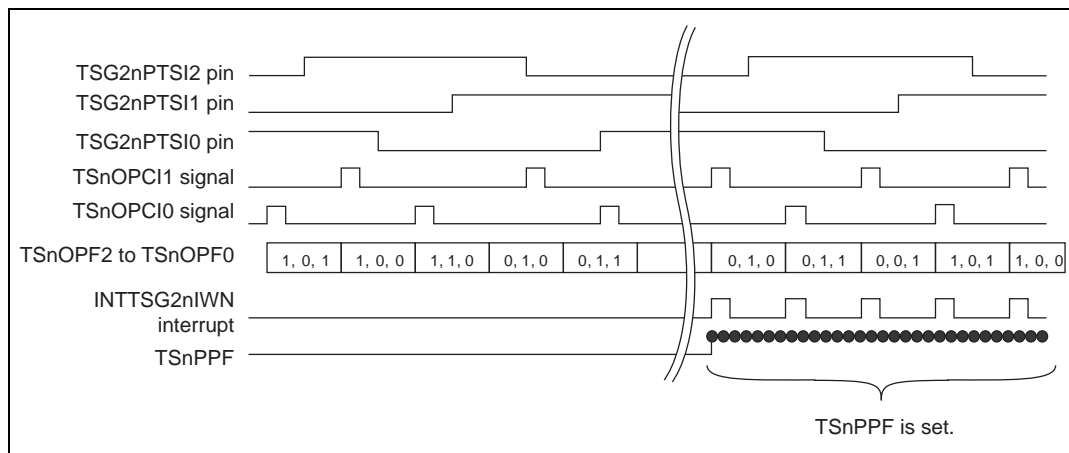

Figure 15-23 Example of Pattern Difference Detection Flag Operation

Operating mode TSnPPF can be used in all operating modes.

Caution 1. TSnPPF is valid only when TSnCTL1.TSnPPC = 1 and TSnSTR0.TSnTE = 1.

Caution 2. When 000 or 111 is input to the TSG2nPTSI2 to TSG2nPTSI0 pins, or when TSnOPF2 to TSnOPF0 are set to 000 or 111, TSnPPF is not set.

15.7.11 Timer Output Pattern Flag (TSnOPF2 to TSnOPF0)

Name Timer output pattern flag (TSnSTR1.TSnOPF2 to TSnOPF0)

Description TSnOPF2 to TSnOPF0 flags indicate the timer output patterns.
For details, see Section 15.11.4, 120-DC Mode, and Section 15.11.5, Software Output Control Function.

Operating mode TSnOPF2 to TSnOPF0 can be used in all operating modes.

15.7.12 Pattern Switch Detection Signal (TSnPTE)

Name Pattern switch detection signal (TSnPTE signal)

Description The TSnPTE signal toggles when the input pattern (TSG2nPTSI2 to TSG2nPTSI0 pins) changes.

The toggle pattern is determined by the TSnPSC bit (TSnOPT0.TSnPSS = 1).

TSnPSC = 0

		TSG2nPTSI2 to TSG2nPTSI0 Pins after Change							
		000	111	101	100	110	010	011	001
Current TSG2nPTSI2 to TSG2nPTSI0 pins	000	-	-	-	-	-	-	-	-
	111	-	-	-	-	-	-	-	-
	101	-	-	-	Toggle	-	-	-	-
	100	-	-	-	-	Toggle	-	-	-
	110	-	-	-	-	-	Toggle	-	-
	010	-	-	-	-	-	-	Toggle	-
	011	-	-	-	-	-	-	-	Toggle
	001	-	-	Toggle	-	-	-	-	-

TSnPSC = 1

		TSG2nPTSI2 to TSG2nPTSI0 Pins after Change							
		000	111	101	100	110	010	011	001
Current TSG2nPTSI2 to TSG2nPTSI0 pins	000	-	-	-	-	-	-	-	-
	111	-	-	-	-	-	-	-	-
	101	-	-	-	-	-	-	-	Toggle
	100	-	-	Toggle	-	-	-	-	-
	110	-	-	-	Toggle	-	-	-	-
	010	-	-	-	-	Toggle	-	-	-
	011	-	-	-	-	-	Toggle	-	-
	001	-	-	-	-	-	-	Toggle	-

Example of operation

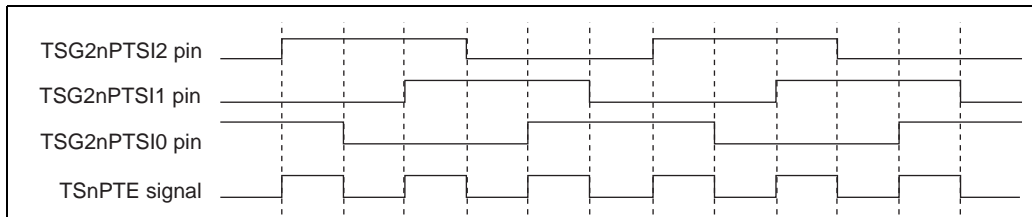

Figure 15-24 Example of Pattern Switch Detection Signal Operation

Operating mode The TSnPTE signal can be used in all operating modes.

Caution The TSnPTE signal is valid only when TSnIOC1.TSnPTS = 1 and TSnSTR0.TSnTE = 1.

15.8 Interrupt Skipping Function

Operation related to the interrupt skipping function is described below.

- Peak interrupts (INTTSG2nIPEK) and valley interrupts (INTTSG2nIVLY) can be skipped.
- TSnCTL4.TSnPIE enables outputting of the INTTSG2nIPEK interrupt and specifies whether to skip the interrupts.
- TSnCTL4.TSnVIE enables outputting of the INTTSG2nIVLY interrupt and specifies whether to skip the interrupts.

When TSnCTL3.TSnRIA is set to 1 (with reload skipping), reload is executed at the same timing as the interrupt after being skipped.

When TSnCTL3.TSnRIA is set to 0 (without reload skipping), reload is executed at the specified reload timing regardless of interrupt skipping.

Caution When a value is written to TSnCTL4, and TSnRCC04 to TSnRCC00 are transferred to the buffer register, the interrupt skipping counter is cleared. Therefore, when the interrupt skipping function is used, interrupt interval may be long temporarily. To avoid this, the interrupt skipping count should be changed with the reload timing being set to the interrupts skipped (TSnCTL3.TSnRIA = 1).

15.8.1 Operation of Interrupt Skipping Function

(1) Interrupt Skipping Operation when TSnPIE = 1 and TSnVIE = 1 in TSnCTL4 (Peak and Valley Interrupt Generation in HT-PWM Mode)

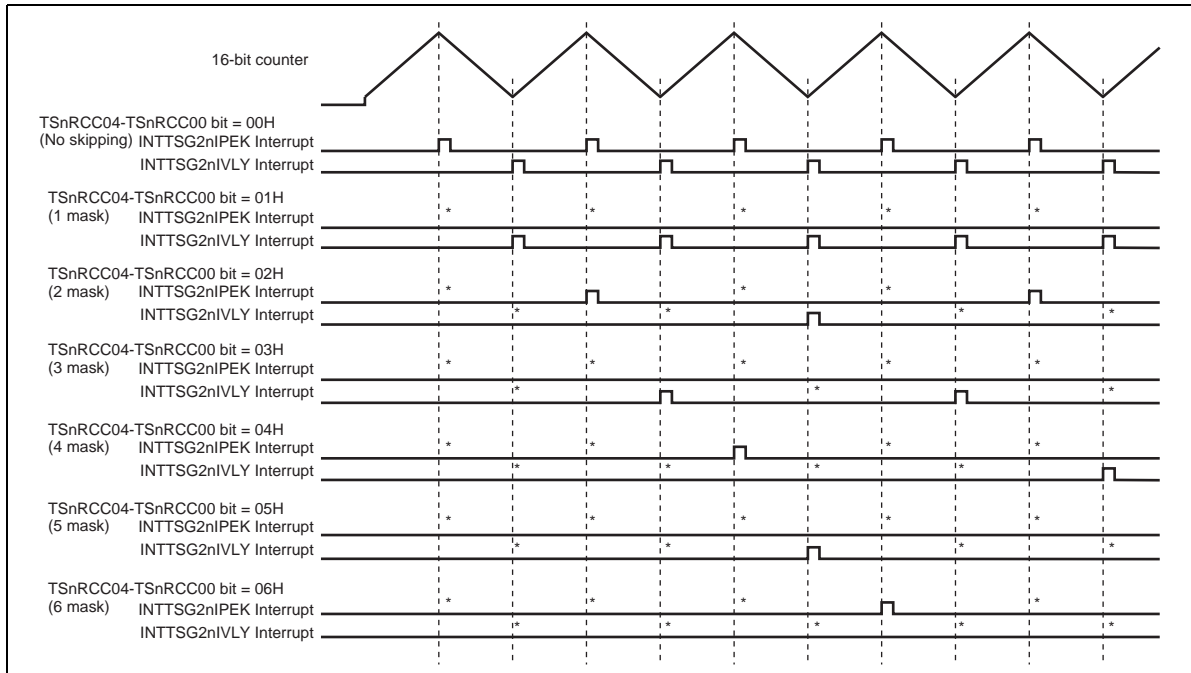

Note * Skipped interrupt request

(2) Interrupt Skipping Operation when TSnPIE = 1 and TSnVIE = 0 in TSnCTL4 Register (only Peak Interrupt Generation in HT-PWM Mode)

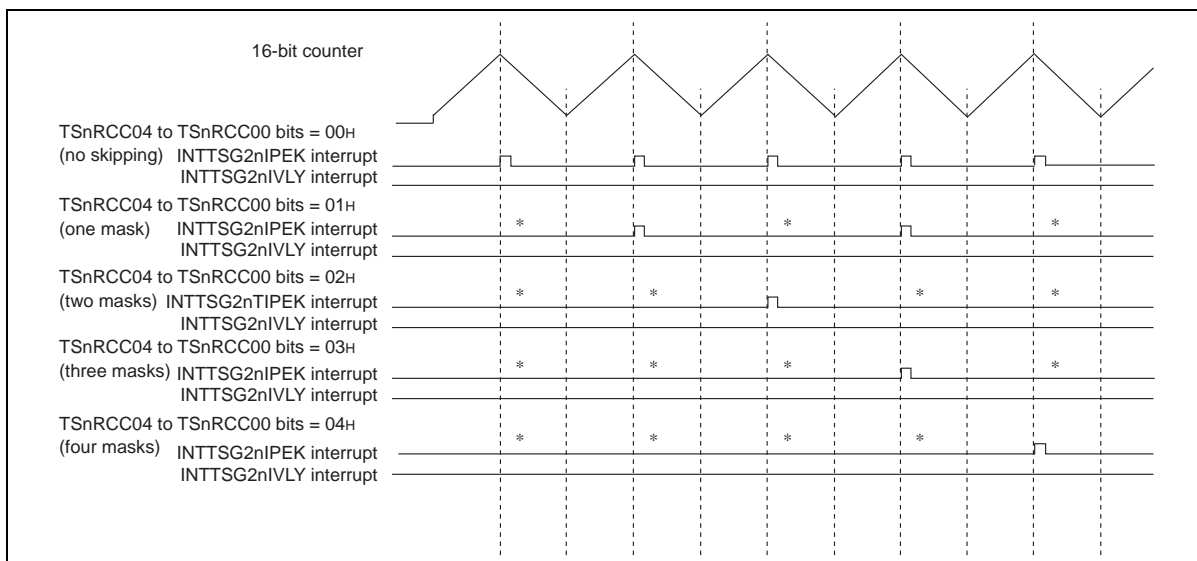

Note * Skipped interrupt request

(3) Interrupt Skipping Operation when TSnPIE = 0 and TSnVIE = 1 in TSnCTL4 Register (only Valley Interrupt Generation in HT-PWM Mode)

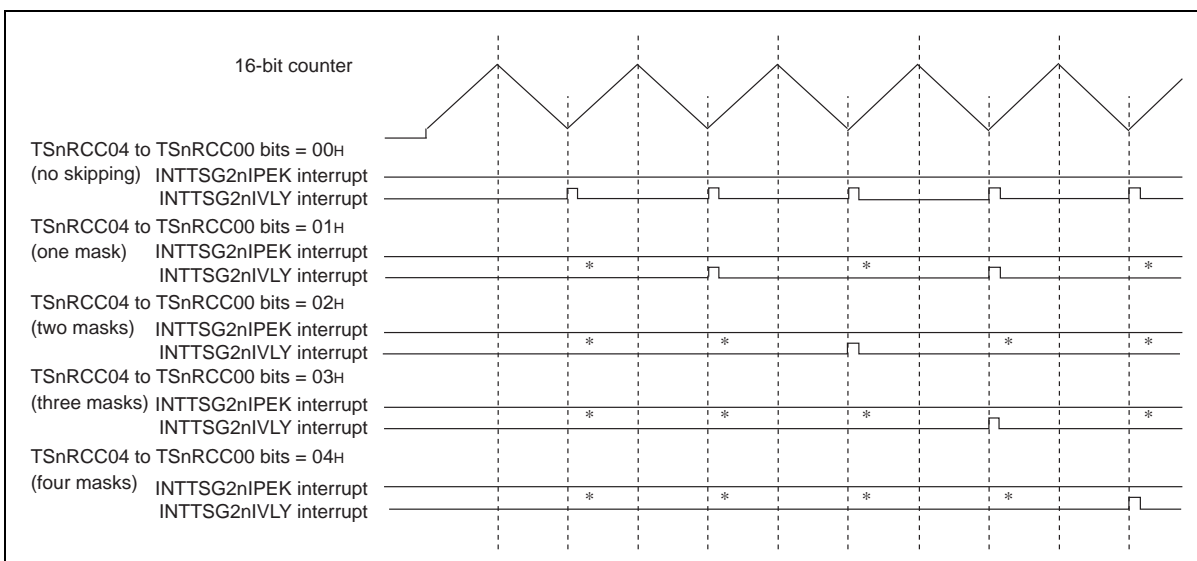

Note * Skipped interrupt request

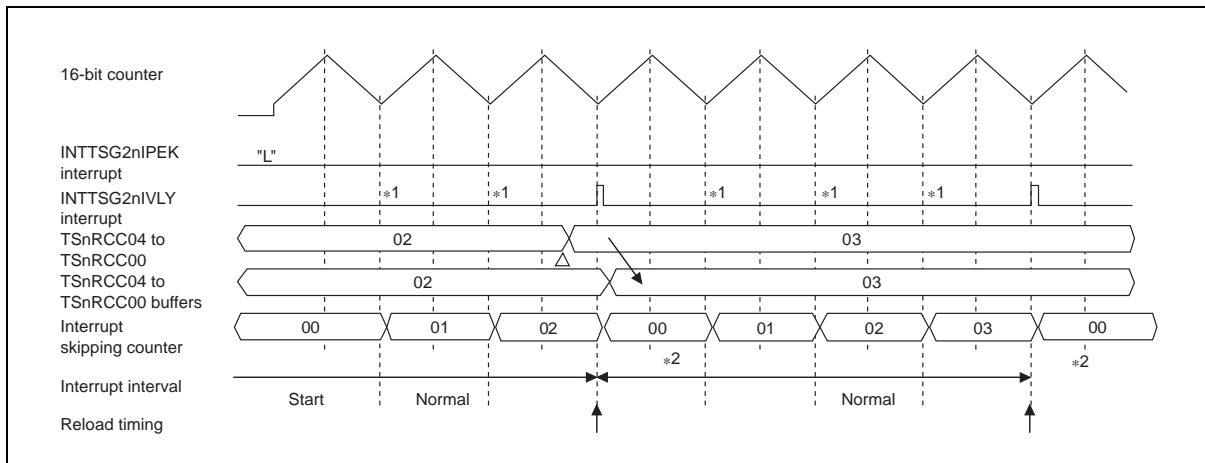

Figure 15-25 When TSnRMC = 0, TSnRIA = 1 in TSnCTL3 (with Reload Skipping)

- Note 1. Skipped interrupt request
- Note 2. Interrupt skipping counter is cleared.

Caution Interrupt interval might be longer.

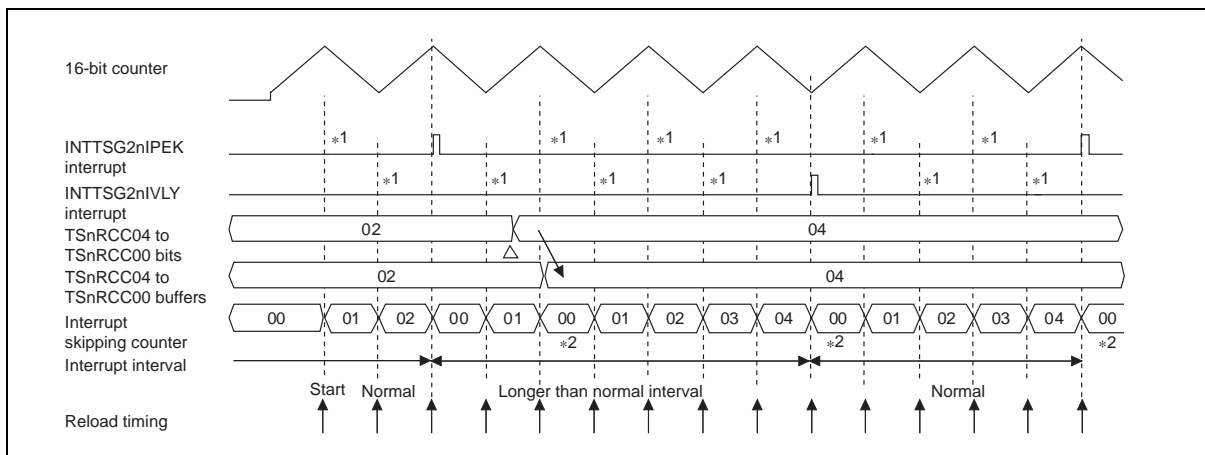

Figure 15-26 When TSnRMC = 0, TSnRIA = 0 in TSnCTL3 (without Reload Skipping)

- Note 1. Skipped interrupt request
- Note 2. Interrupt skipping counter is cleared.

Caution Interrupt interval might be longer.

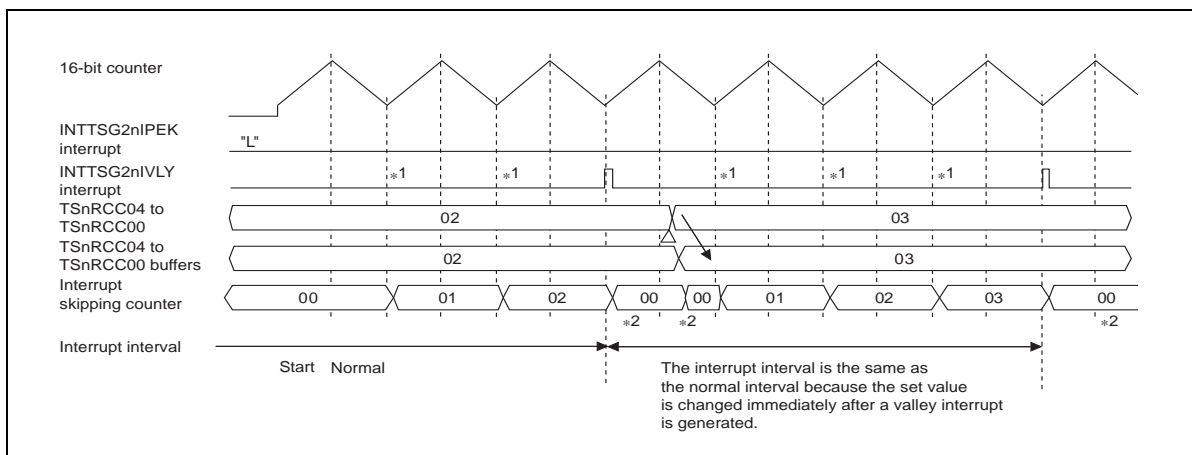

Figure 15-27 When TSnrMC = 1 in TSnrCTL3 (Anytime Rewrite Mode)

- Note 1. Skipped interrupt request
- Note 2. Interrupt skipping counter is cleared

Caution Interrupt interval might be longer.

Note After rewriting, the value is reflected immediately regardless of the reload timing. The interrupt skipping counter is cleared when the value is transferred to the TSnrCC04 to TSnrCC00 buffers, not when the pertinent register is rewritten.

15.8.2 Example of Operation when Peak Interrupt is Generated (in PWM Mode)

Operation related to the interrupt skipping function in PWM mode is described below.

- Valley interrupts (INTTSG2nIPEK) can be skipped. In PWM mode, it is generated by compare match of TSnCMP0 buffer register and 16-bit counter.
- TSnCTL4.TSnPIE enables outputting of the INTTSG2nIPEK interrupt and specifies whether to skip the interrupts.
- The setting of TSnCTL4.TSnVIE is disabled. At this time, the INTTSG2nIVLY interrupt is not generated. When TSnCTL3.TSnRIA is set to 1 (with reload skipping), reload is executed at the same timing as the interrupt after being skipped.

Caution When a value is written to TSnCTL4, and TSnRCC04 to TSnRCC00 are transferred to the buffer register, the interrupt skipping counter is cleared. Therefore, when the interrupt skipping function is used, interrupt interval may be long temporarily. To avoid this, the interrupt skipping count should be changed with the reload timing being set to the interrupts skipped (TSnCTL3.TSnRIA = 1).

(1) Example of Operation

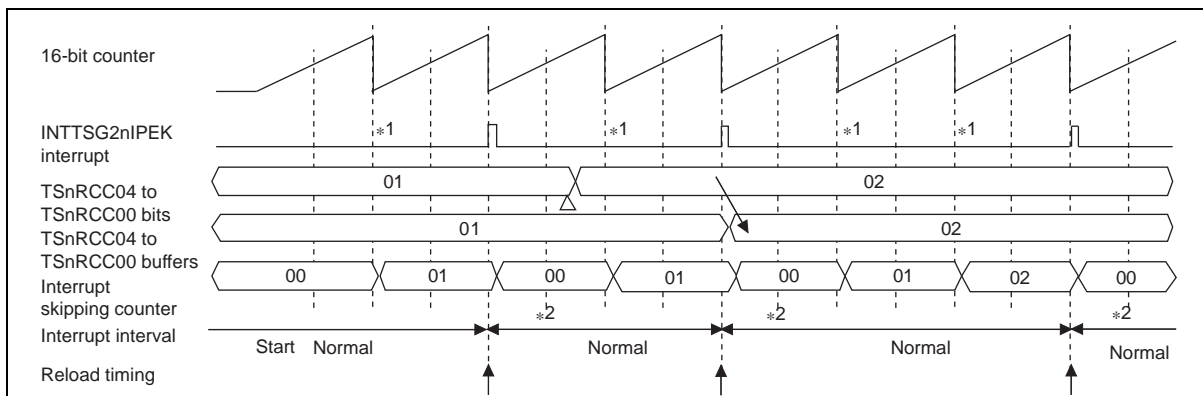

Figure 15-28 When TSnCTL3.TSnRMC = 0, TSnRIA = 1, TSnCTL4.TSnPRE = 1 (Recommended Setting)

- Note 1. Skipped interrupt request
 Note 2. Interrupt skipping counter is cleared.

Note When TSnCTL3.TSnRIA = 1, reload is executed at the same timing as the interrupt after being skipped.

15.9 A/D Conversion Trigger Function

A/D conversion trigger operation is described below.

TSnDCMP0W and TSnDCMP2 are used as compare registers of the A/D conversion trigger function.

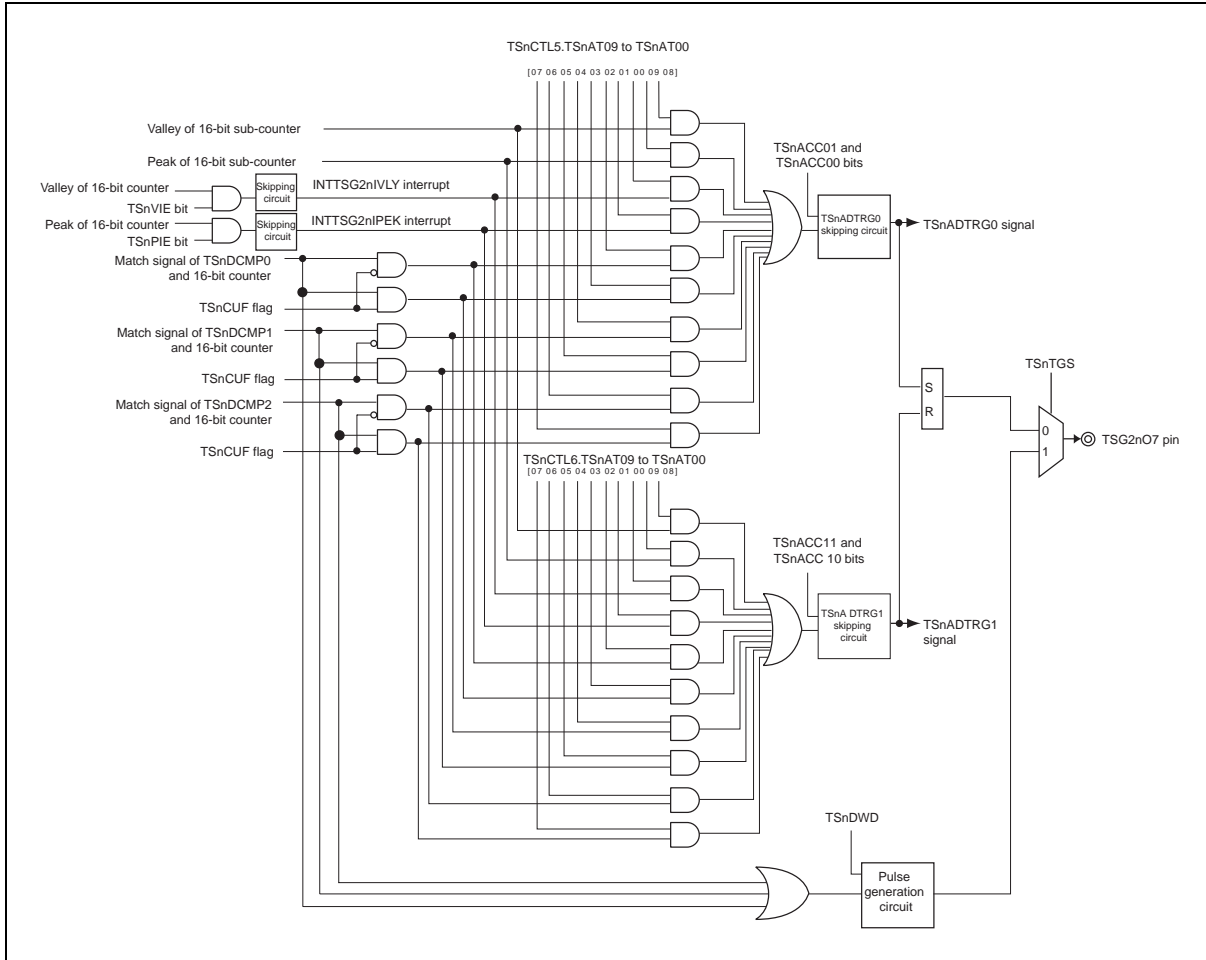

Figure 15-29 A/D Conversion Trigger and Diagnostic Output Control Circuit

As shown in Figure 15-29, a logical ORed signal can be generated by selecting the compare match of TSnDCMP0 to TSnDCMP2 with the 16-bit counter, a peak interrupt (INTTSG2nIPEK) and a valley interrupt (INTTSG2nIVLY) of the 16-bit counter, the peak timing of 16-bit sub-counter, and the valley timing of 16-bit sub-counter.

TSG2n has two channels of the identical A/D conversion trigger control circuits, which can be controlled independently. TSG2n also provides the A/D conversion trigger skipping function with the skipping rate of 1/1, 1/2, 1/4, or 1/8.

15.9.1 Operation of A/D Conversion Trigger

TSG2n has a function to generate A/D conversion start triggers (TSnADTRG0 and TSnADTRG1 signals) by selecting any of ten trigger sources as required. The trigger sources are selected by TSnAT09 to TSnAT00 in TSnCTL5 and TSnAT19 to TSnAT10 in TSnCTL6.

(1) TSnADTRG0/TSnADTRG1 Signal Output Control (TSnCTL5 and TSnCTL6)

[Trigger source]

- TSnAT00/TSnAT10 = 1 : A valley interrupt (INTTSG2nIVLY) causes an A/D conversion trigger pulse to be generated.
- TSnAT01/TSnAT11 = 1 : A peak interrupt (INTTSG2nIPEK) causes an A/D conversion trigger pulse to be generated.
- TSnAT02/TSnAT12 = 1 : While the 16-bit counter is counting up, a TSnDCMP0 compare match enables A/D conversion trigger to be generated.
- TSnAT03/TSnAT13 = 1 : While the 16-bit counter is counting down, a TSnDCMP0 compare match enables A/D conversion trigger to be generated.
- TSnAT04/TSnAT14 = 1 : While the 16-bit counter is counting up, a TSnDCMP1 compare match enables A/D conversion trigger to be generated.
- TSnAT05/TSnAT15 = 1 : While the 16-bit counter is counting down, a TSnDCMP1 compare match enables A/D conversion trigger to be generated.
- TSnAT06/TSnAT16 = 1 : While the 16-bit counter is counting up, a TSnDCMP2 compare match enables A/D conversion trigger to be generated.
- TSnAT07/TSnAT17 = 1 : While the 16-bit counter is counting down, a TSnDCMP2 compare match enables A/D conversion trigger to be generated.
- TSnAT08/TSnAT18 = 1 : A valley timing of the 16-bit sub-counter (at a switch from decrementing to incrementing) enables A/D conversion trigger to be generated.
- TSnAT09/TSnAT19 = 1 : A peak timing of 16-bit sub-counter (at a switch from incrementing to decrementing) enables A/D conversion trigger to be generated.

[Skipping setting]

- TSnACC01 and TSnACC00, and TSnACC11 and TSnACC10 : Set the skipping rate of the TSnADTRG0 and TSnADTRG1 signals, respectively.

All A/D conversion triggers selected by TSnAT09 to TSnAT00 and TSnAT19 to TSnAT10 are logically ORed, and the resultant signals are subjected to skipping control specified by TSnACC01 and TSnACC00, and TSnACC11 and TSnACC10, and then the TSnADTRG0 and TSnADTRG1 signals are generated.

A peak interrupt (INTTSG2nIPEK) and a valley interrupt (INTTSG2nIVLY) selected by TSnAT00 and TSnAT01, and TSnAT10 and TSnAT11 are interrupt signals obtained after skipped. Therefore, they are output at the timing according to interrupt skipping control. If the interrupt output is not enabled by TSnCTL4.TSnPIE and TSnVIE, A/D conversion trigger is not output.

TSnACC01, TSnACC00, and TSnAT09 to TSnAT00, and TSnACC11, TSnACC10, and TSnAT19 to TSnAT10 can be rewritten during timer operation.

If A/D conversion trigger setting bits are rewritten during operation, the rewritten values are reflected on the A/D conversion trigger output status immediately. Such control bits are rewritten at anytime regardless of operating modes. If a write access is made to TSnCTL5 and TSnCTL6 (including a rewrite of the same value), the A/D conversion trigger skipping counter is cleared and starts counting from zero.

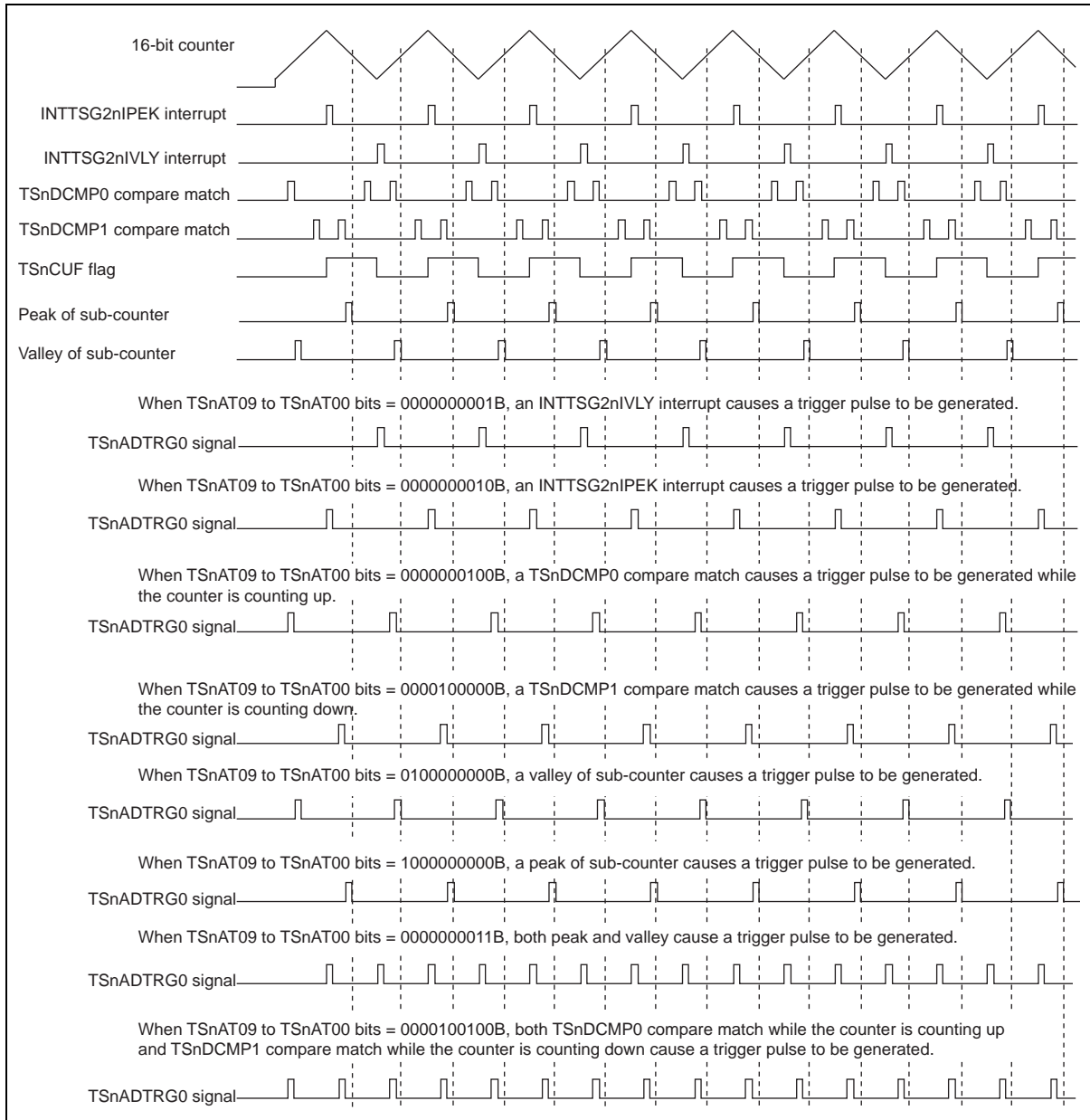

Figure 15-30 When TSnPIE = 1, TSnVIE = 1, and TSnRCC04 to TSnRCC00 = 00_B in TSnCTL4, and TSnACC01 and TSnACC00 = 00_B in TSnCTL5 (HT-PWM Mode)

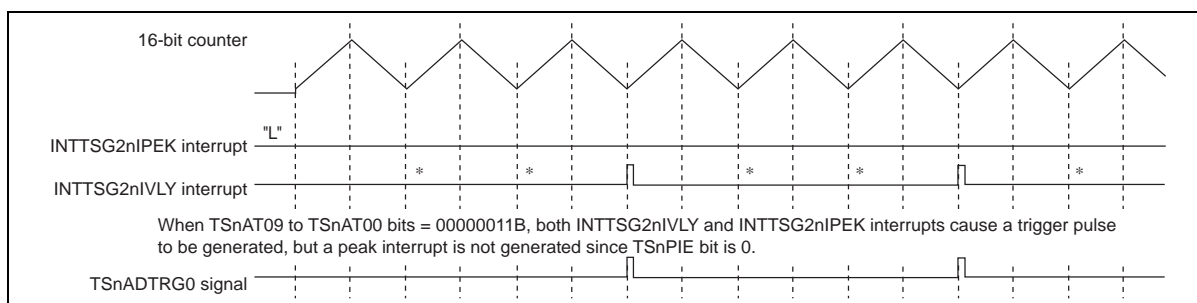

Figure 15-31 When TSnPIE = 0, TSnVIE = 1, and TSnRCC04 to TSnRCC00 = 02_B in TSnCTL4 and TSnACC01 and TSnACC00 = 00_B in TSnCTL5 (HT-PWM Mode)

Note * Skipped interrupt request

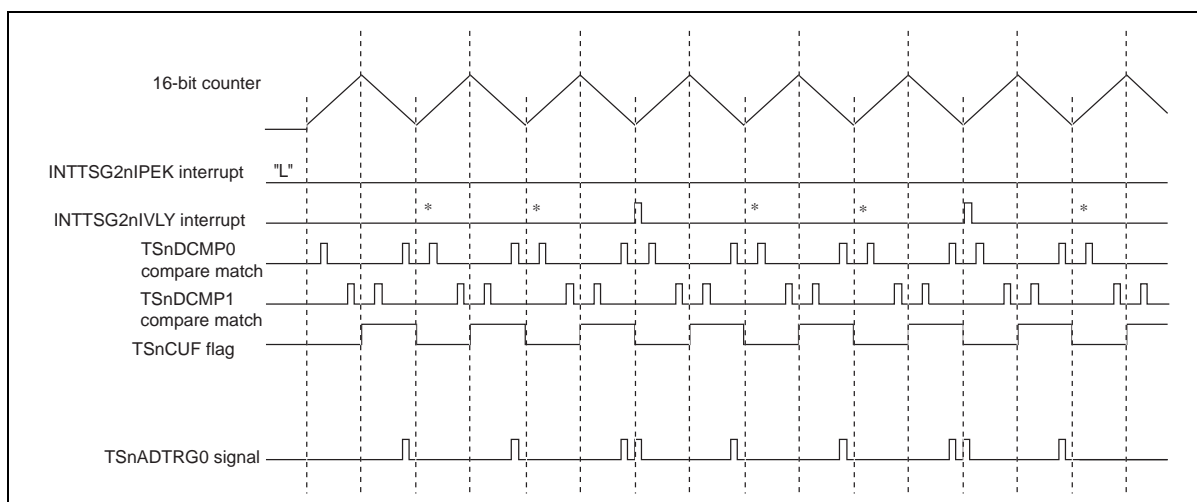

Figure 15-32 When TSnPIE = 0, TSnVIE = 1, and TSnRCC04 to TSnRCC00 = 02_B in TSnCTL4 and TSnACC01 and TSnACC00 = 00_B, and TSnAT09 to TSnAT00 = 00001001^B in TSnCTL5 (HT-PWM Mode)

Note * Skipped interrupt request

(2) A/D Conversion Trigger Skipping Function

Example of operation of the A/D conversion trigger skipping function is shown in Figure 15-70.

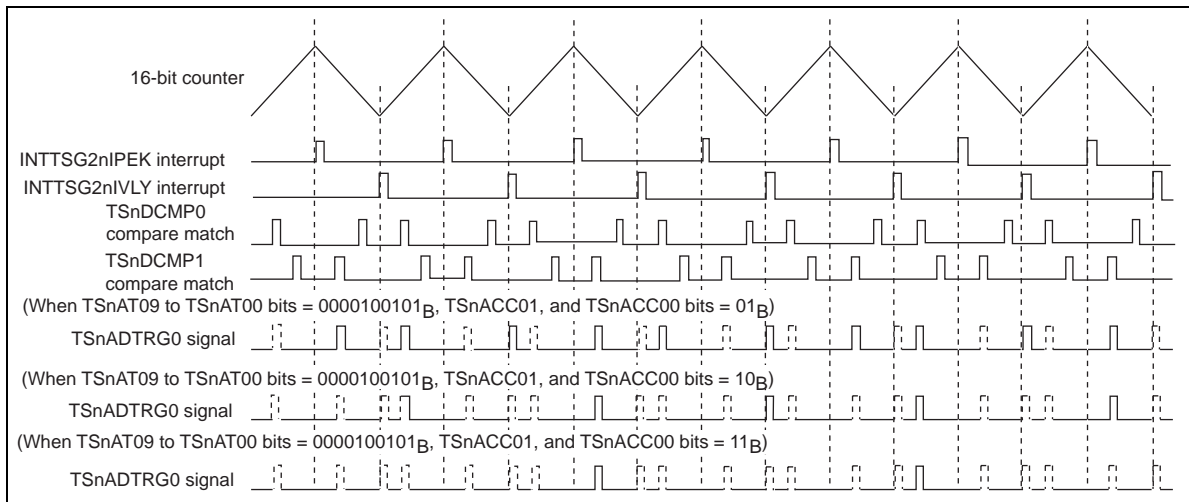

Figure 15-33 Example of Operation of A/D Conversion Trigger Skipping Function

Note Broken-lined pulses indicate A/D conversion trigger pulses skipped by the A/D conversion trigger skipping function.

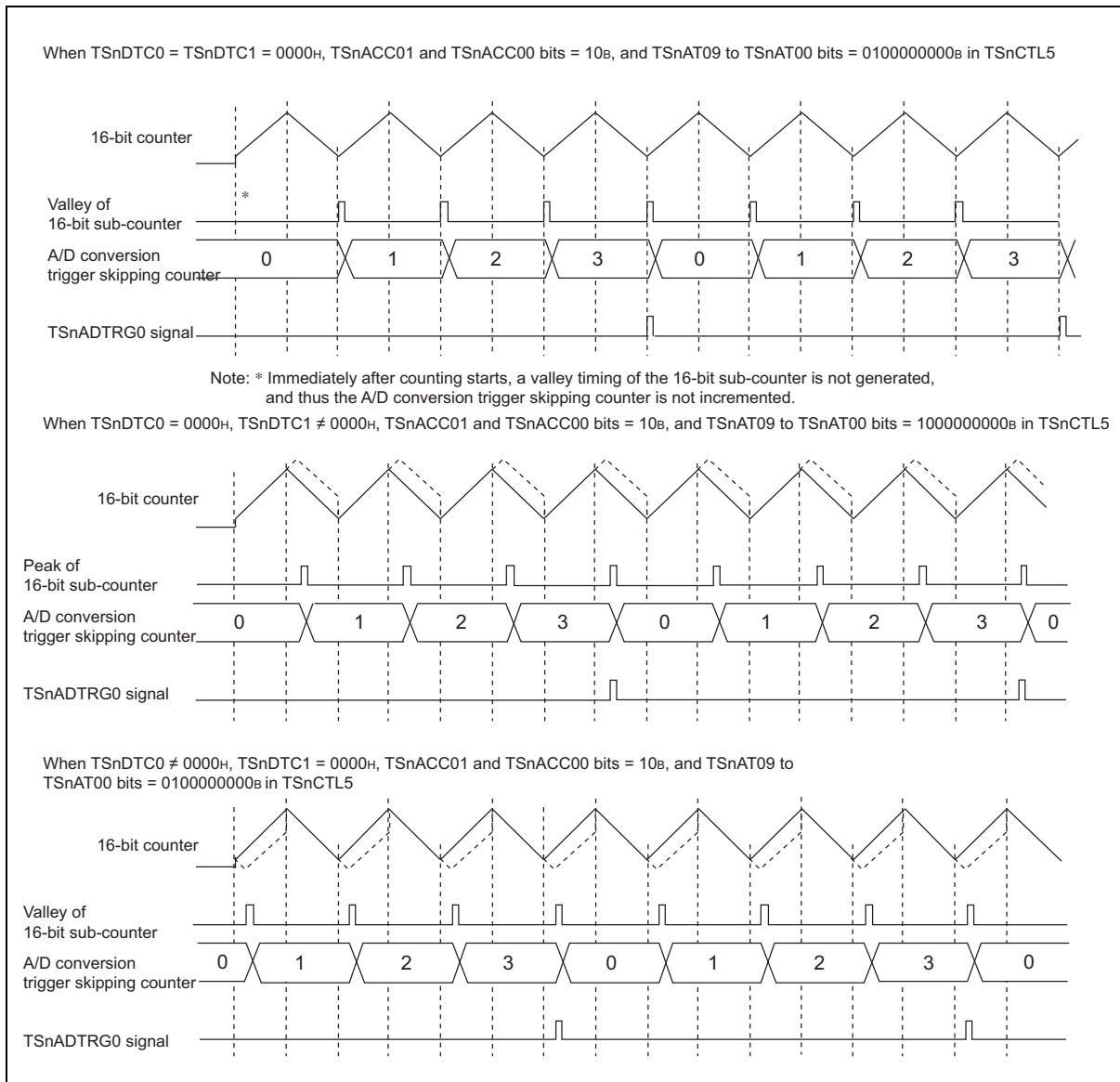

Figure 15-34 Example of Operation of A/D Conversion Trigger Skipping Function

(3) Notes on A/D Conversion Trigger

- If the same value is written to TSnDCMP0 and TSnDCMP1 or TSnDCMP2, and the same condition (when the 16-bit counter increments or decrements) is set as the valid A/D conversion trigger, A/D conversion trigger skipping counter is incremented by one and one trigger pulse is output upon a match of the 16-bit counter with these registers.
- In PWM mode, SP-PWM mode, and 120-DC mode, a valley interrupt (INTTSG2nIVLY) is not generated. Only a peak interrupt (INTTSG2nIPEK) is valid.
- In 120-DC mode, when the 16-bit counter is cleared during the carrier period due to switch of the output pattern, the A/D conversion trigger is not generated if TSnDCMP2 to TSnDCMP0 values do not match with the 16-bit counter value and a peak interrupt (INTTSG2nIPEK) is not generated.

15.10 Error/Warning Interrupt

15.10.1 Error Interrupt Function

If the simultaneous active state of the positive phase and inverse phase is detected after the error interrupt function is enabled (TSnIOC1.TSnEOC = 1), TSnSTR2.TSnTBF is set, and an error interrupt (INTTSG2nIER) of TSG2n is generated. Whether or not to detect an error of each phase (TSG2nO1 and TSG2nO2, TSG2nO3 and TSG2nO4, and TSG2nO5 and TSG2nO6 pins) can be selected by TSnCTL1.TSnTBA2 to TSnTBA0, respectively.

When an error occurs, outputs of the TSG2nO1 to TSG2nO6 pins can be set to high-impedance. For details, see section 19.4.1, Hi-Z Control Functions.

The following table shows whether or not the simultaneous active state of the positive phase and inverse phase can be detected in each mode.

Mode	Positive Phase and Inverse Phase Simultaneous Active State Detection
PWM mode	Possible
HT-PWM mode	Possible
SP-PWM mode	Possible
120-DC mode	Possible

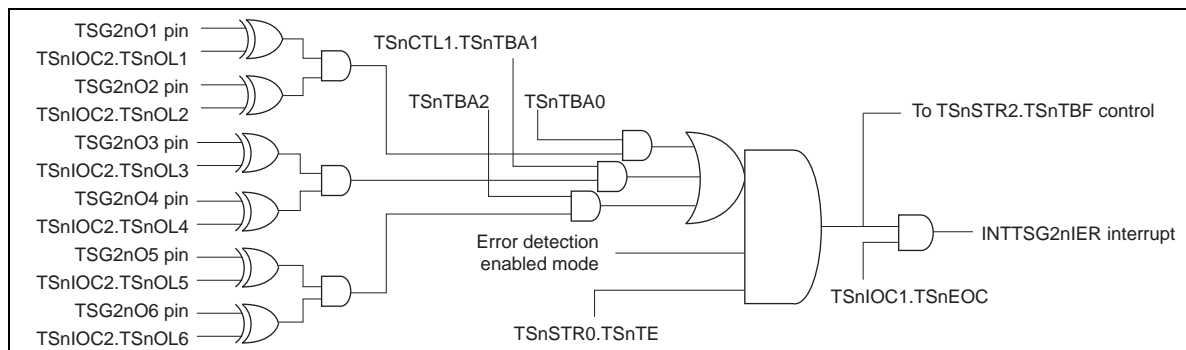

Figure 15-35 Error Interrupt (INTTSG2nIER) Generation Control Circuit

Caution When an error interrupt is generated, the error status should be canceled within an error interrupt handling. Otherwise, subsequent error interrupts are not generated.

(1) PWM Mode and 120-DC Mode

In PWM mode, if TSnCMP1 and TSnCMP2, and TSnCMP3 and TSnCMP4 are set so that the TSG2nO1 and TSG2nO2 pins output the active level simultaneously, an error interrupt (INTTSG2nIER) is generated. With the same setting, if TSnCMP5, TSnCMP6, TSnCMP7, TSnCMP8, TSnCMP9, TSnCMP10, TSnCMP11, and TSnCMP12 are set so that the TSG2nO3 and TSG2nO4, and TSG2nO5 and TSG2nO6 pins output the active level simultaneously, an error interrupt (INTTSG2nIER) is generated.

In 120-DC mode, if TSnCMP1, TSnCMP2, TSnCMP5, TSnCMP6, TSnCMP9, and TSnCMP10, TSnCMP3, TSnCMP4, TSnCMP7, TSnCMP8, TSnCMP11, and TSnCMP12, and TSnPAT0W and TSnPAT1W are set so that the TSG2nO1 and TSG2nO2 pins output the active level simultaneously, an error interrupt (INTTSG2nIER) is generated. With the same setting, the TSG2nO3 and TSG2nO4, and TSG2nO5 and TSG2nO6 pins also output the active level simultaneously, an error interrupt (INTTSG2nIER) is generated.

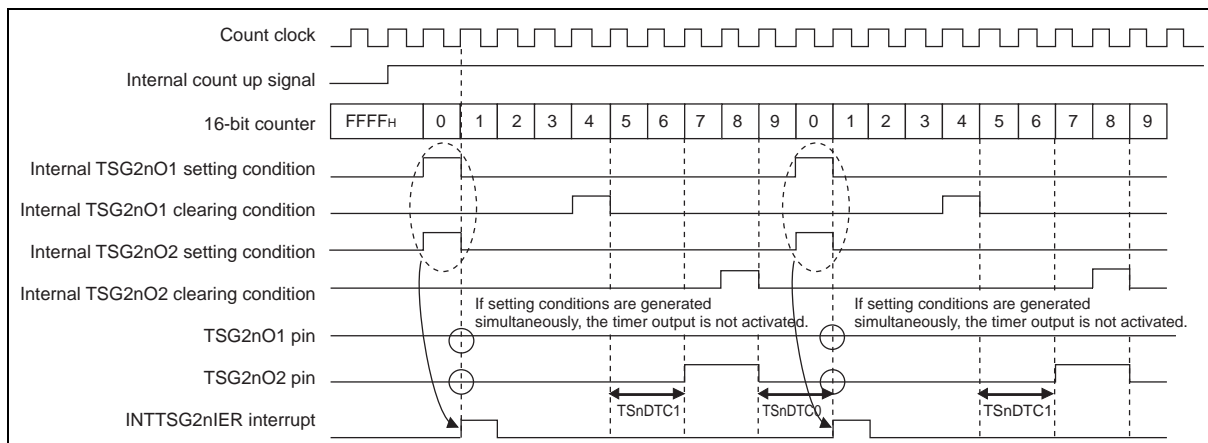

Figure 15-36 Example of Error Interrupt (INTTSG2nIER) Generation (PWM Mode)

Note TSG2nO3 and TSG2nO4, and TSG2nO5 and TSG2nO6 behave the same.

When the active level of output is switched by operating TSnIOC2.TSnOL1 and TSnOL2, an error interrupt is generated as shown in Figure 15-74.

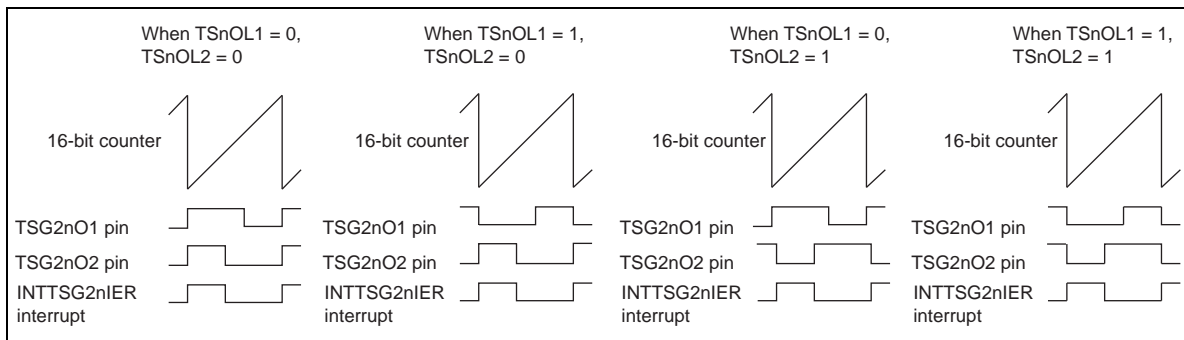

Figure 15-37 Example of Error Interrupt (INTTSG2nIER) Generation for each Active Level

(2) HT-PWM Mode and SP-PWM Mode

Either TSG2n dead time setting register 0 or 1 (TSnDTC0 or TSnDTC1) is 0000_H, an error may occur.

Note If an error occurs when the dead time control function is used (both TSnDTC0 and TSnDTC1 are not 0000_H), internal circuit failure may occur.

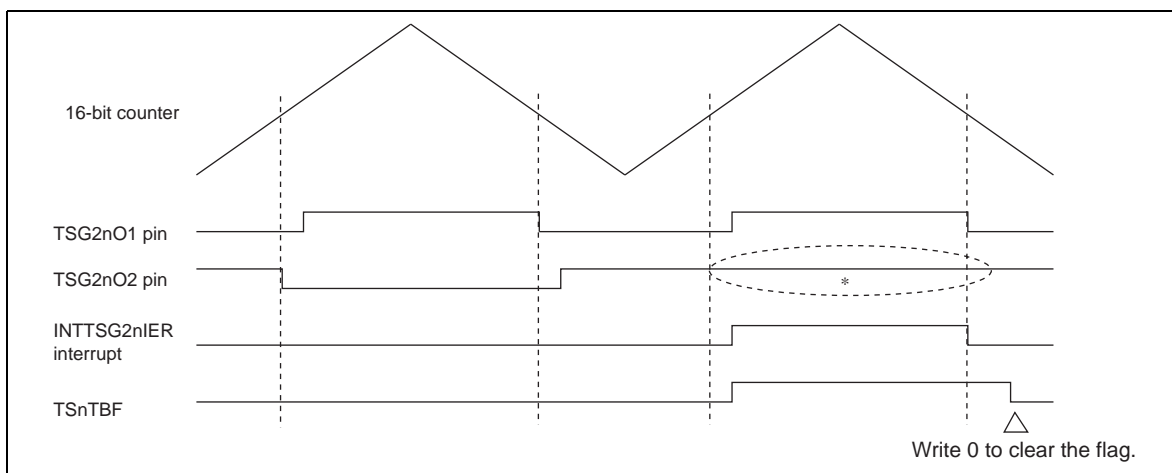

Figure 15-38 Example of Error Interrupt Operation

Note * TSG2nO2 pin control circuit failure occurs.

15.10.2 Warning Interrupt Function

TSG2n has a warning interrupt (INTTSG2nIWN).

Warning interrupt (INTTSG2nIWN) is generated when any of the following conditions is detected.

For details, see Section 15.7, Flags.

- When simultaneous change in two or more pins of TSG2nPTS12 to TSG2nPTS10 is detected
See Section 15.7.4, Noise Detection Flag (TSnNDF).
- When reversal is detected of the TSG2nPTS12 to TSG2nPTS10 pin input pattern
See Section 15.7.7, Pattern Reversal Detection Flag (TSnPRF).
- When 000 or 111 is detected from the TSG2nPTS12 to TSG2nPTS10 pins
See Section 15.7.6, Pattern Error Detection Flag (TSnPEF).
- When a toggle of the TSnPTS12 to TSG2nPTS10 pins is generated three times or more between TSnOPCI0 and TSnOPCI1 signal triggers.
See Section 15.7.8, TSG2nPTS12 to TSG2nPTS10 Pin Abnormal Toggle Detection Flag (TSnPTF).
- When the TSnOPCI0 and TSnOPCI1 signal triggers are detected simultaneously
See Section 15.7.9, TSnOPCI0 and TSnOPCI1 Signal Simultaneous Trigger Detection Flag (TSnTDF).
- When the phase difference between the input pattern (TSG2nPTS12 to TSG2nPTS10 pins) and output patterns (TSnOPF2 to TSnOPF0) is detected
See Section 15.7.10, Pattern Phase Difference Detection Flag (TSnPPF).

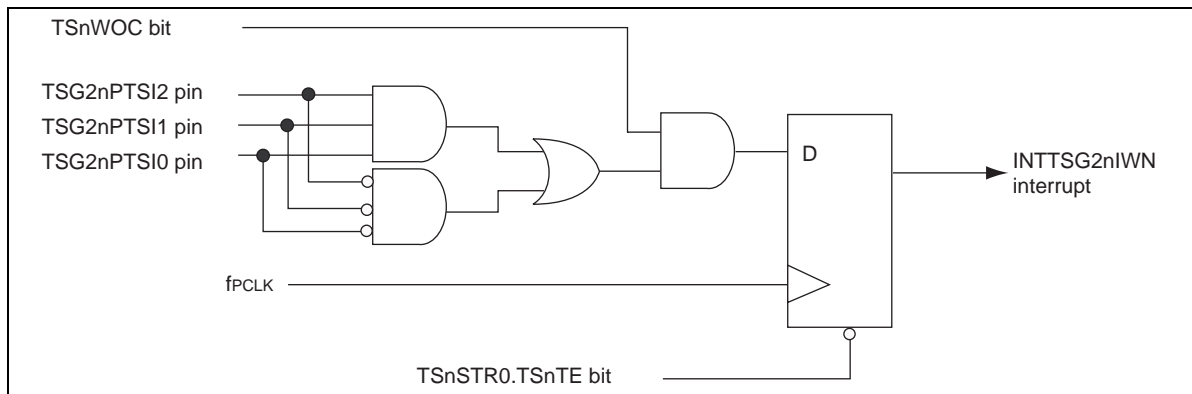

Figure 15-39 Detection of Abnormality of TSG2nPTS12 to TSG2nPTS10 Pins

15.11 Operating Modes

Table 15-47 List of Modes

TSnCTL0 Register		Timer Modes
TSnMD1	TSnMD0	
0	0	PWM mode
0	1	HT-PWM mode (HT-PWM)
1	0	Shifted-pulse - pulse width modulation mode (SP-PWM)
1	1	120-DC mode

15.11.1 PWM Mode

Overview A PWM signal is output at the TSG2nO1 to TSG2nO6 pins according to set timing/clear timing of TSnCMP1 to TSnCMP12 registers with the PWM period set in the TSnCMP0 register.

- Prerequisites**
- Set the set timing to the compare register with an even number:
TSnCMP2 (set timing of the TSG2nO1 output), TSnCMP4 (set timing of the TSG2nO2 output), TSnCMP6 (set timing of the TSG2nO3 output), TSnCMP8 (set timing of the TSG2nO4 output), TSnCMP10 (set timing of the TSG2nO5 output) and TSnCMP12 (set timing of the TSG2nO6 output)
 - Set the clear timing to the compare register with an odd number:
TSnCMP1 (clear timing of the TSG2nO1 output), TSnCMP3 (clear timing of the TSG2nO2 output), TSnCMP5 (clear timing of the TSG2nO3 output), TSnCMP7 (clear timing of the TSG2nO4 output), TSnCMP9 (clear timing of the TSG2nO5 output) and TSnCMP11 (clear timing of the TSG2nO6 output)

Functional description Set the PWM period and set/clear timing of the TSG2nO1 to TSG2nO6 outputs. Set TSnTRG0.TSnTS = 1 to start the timer counter.

The TSG2nO1 to TSG2nO6 outputs are set to the inactive state at the same time the counting begins. The outputs are set to the active state by the match of the buffer registers TSnCMP2, TSnCMP4, TSnCMP6, TSnCMP8, TSnCMP10, and TSnCMP12 with the 16-bit counter.

Next, the TSG2nO1 to TSG2nO6 outputs are set to the inactive state by the match of the buffer registers TSnCMP1, TSnCMP3, TSnCMP5, TSnCMP7, TSnCMP9, and TSnCMP11 with the 16-bit counter.

During counting, a compare match interrupt (INTTSG2nI00 to INTTSG2nI12) is generated by the match of the buffer register TSnCMP0 to TSnCMP12 with the 16-bit counter.

Caution Reload is executed when writing to the TSnCMP1 register at TSnCTL3.TSnRMC = 0. Therefore, even when it is needed to rewrite only the value of the TSnCMP0 register, a write operation to the TSnCMP1 register is necessary. When only the TSnCMP0 register is rewritten, reload is not done.

Note The PWM mode is set when TSnCTL0.TSnMD1 and TSnMD0 = 00_B.

(a) When TSnCMP0 and TSnCMP1 to TSnCMP12 are Not Rewritten during Timer Operation

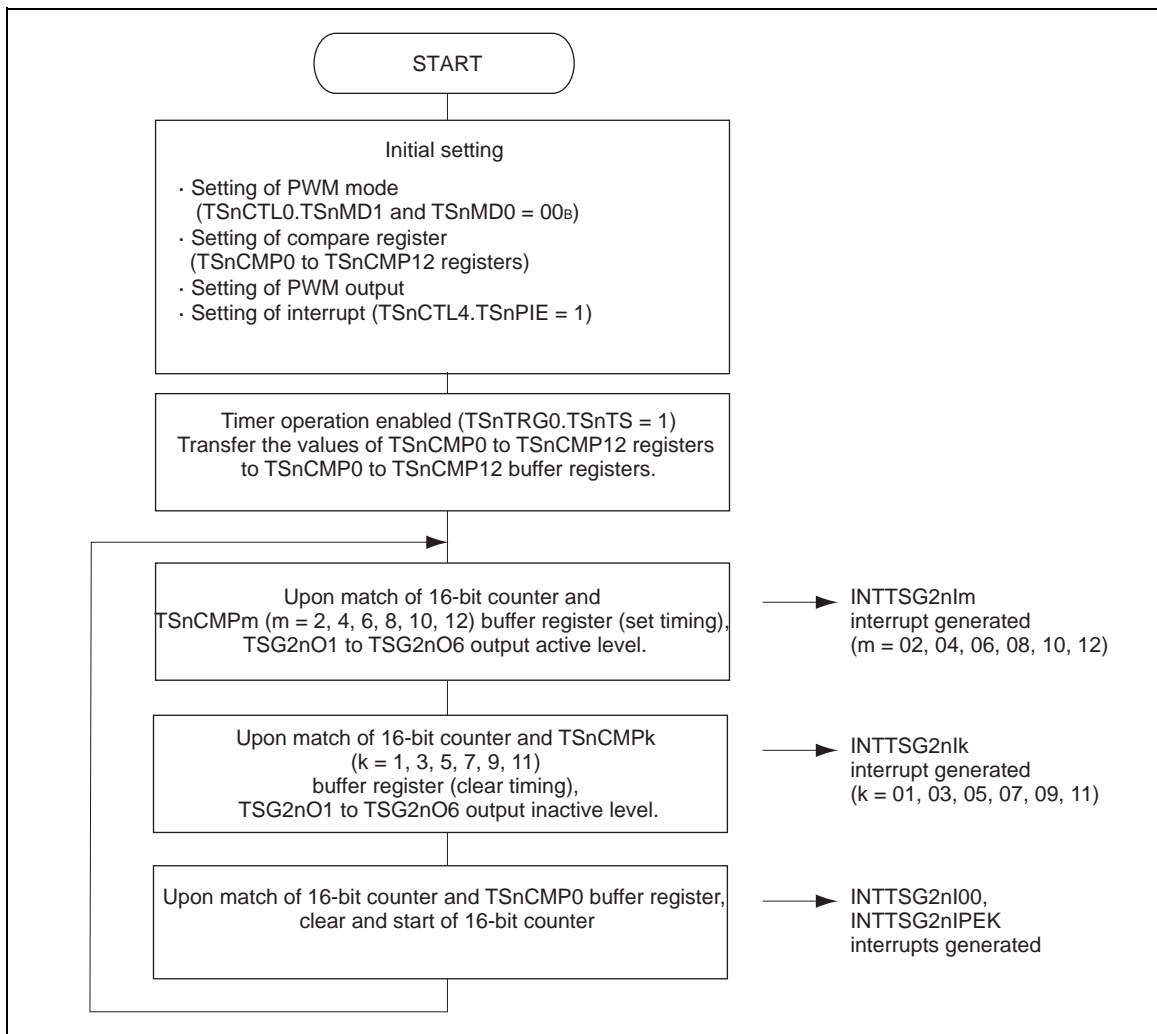

Figure 15-40 Basic Operation Flow of PWM Mode (1/2)

(b) When TSnCMP0 and TSnCMP1 to TSnCMP12 are Rewritten during Timer Operation

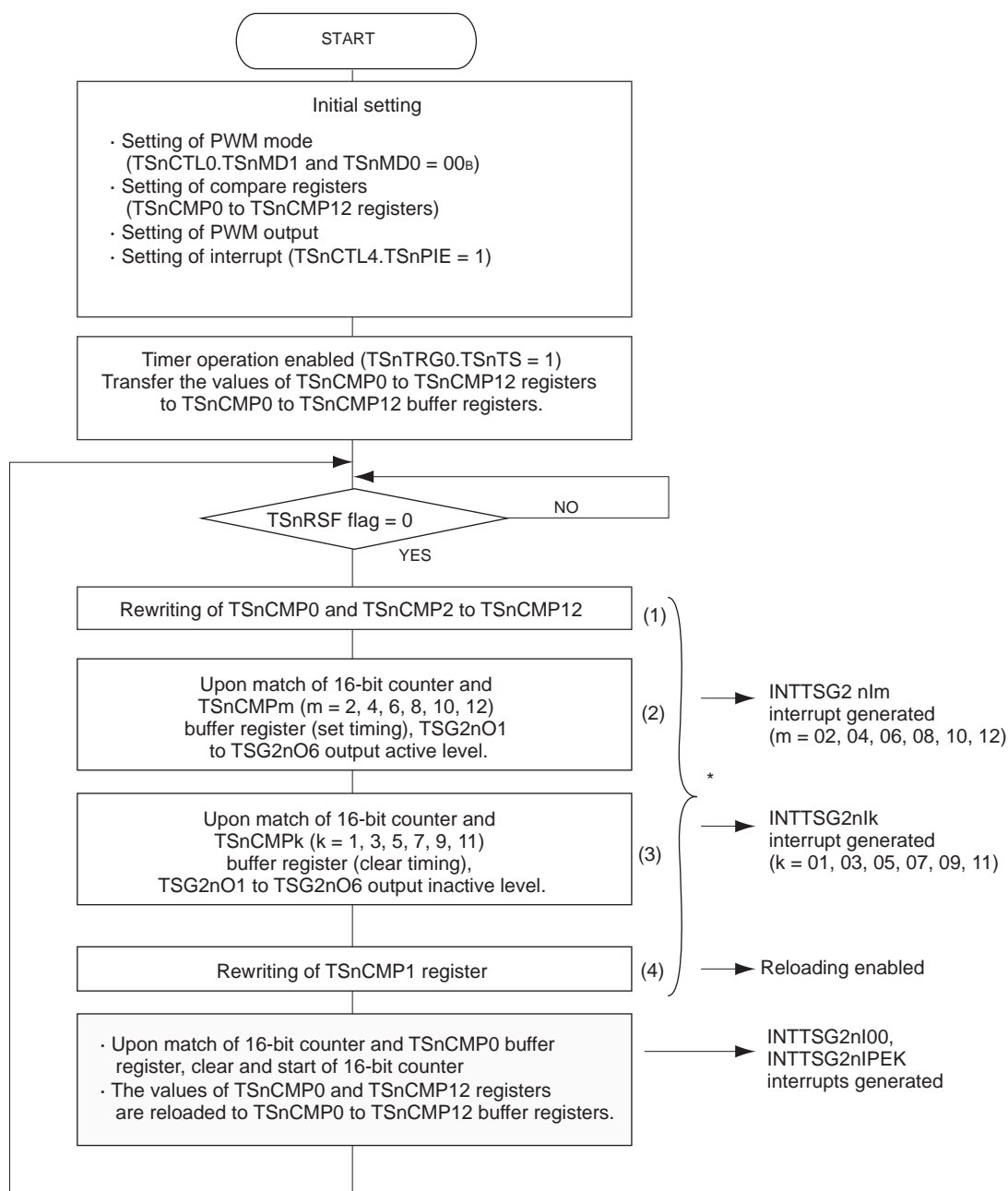

Figure 15-40 Basic Operation Flow of PWM Mode (2/2)

Note The timing of (2) and (3) might be different depending on the rewriting timing of (1) and (4) and the TSnCMP1 value. Please make sure that (1) is always done before (4).

Caution Please rewrite compare registers after confirming that the reload request flag TSnRSF is 0.

(1) List of Operations in PWM Mode

Table 15-48 Counter Functions in PWM Mode

Operation		Setting Conditions
16-bit counter	Start	TSnTRG0.TSnTS = 0 → 1, or a simultaneous start trigger
	Clear	Compare match of TSnCMP0 buffer register and 16-bit counter
	Stop	TSnTRG1.TSnTT = 0 → 1

Table 15-49 Functions of Compare Registers and Dead Time Setting Register in PWM Mode

Register	Rewriting Method	Rewrite during Operation	Function
TSnCMP0	Reload/Anytime rewrite	Possible	Setting period
TSnCMPm (m = 1 to 12)	Reload/Anytime rewrite	Possible	Setting set/clear timing
TSnDCMP0W, TSnDCMP2	Reload/Anytime rewrite	Possible	Diagnostic output or A/D conversion trigger
TSnDTC0, TSnDTC1	Reload	Possible*	Setting dead time

Note * Please refer to (3), Controlling Dead Time in PWM Mode.

Table 15-50 Timer Output in PWM Mode

Pin	Function
TSG2nOm (m = 1 to 6)	PWM output by compare match of TSnCMPk buffer register and 16-bit counter (k = 1 to 12)
TSG2nO7	Diagnostic signal output or pulse output by A/D conversion trigger

Table 15-51 Interrupt Requests in PWM Mode

Interrupt	Function
INTTSG2nIm (m = 00 to 12)	Compare match of TSnCMPm buffer register and 16-bit counter (m = 0 to 12)
INTTSG2nIER	Error (simultaneous active state of TSG2nO1 and TSG2nO2, or TSG2nO3 and TSG2nO4, or TSG2nO5 and TSG2nO6)
INTTSG2nIVLY	-
INTTSG2nIPEK	Peak interrupt (generated at the same timing as INTTSG2nI00)
INTTSG2nIWN	Warning interrupt

Note “-”: Not available in PWM mode

Table 15-52 Compare Match Timing in PWM Mode

Compare Match	Timing
TSnCMP0	When 16-bit counter changes from TSnCMP0 to 0000 _H
TSnCMPm (m = 1 to 12)	After detecting the match of 16-bit counter and TSnCMPm (m = 1 to 12)

Table 15-53 Example of Setting each Timer Output Condition in PWM Mode

Pin	Item	Output Period	Output Duty	
			Output Condition	Setting Condition
TSG2nOm (m = 1 to 6)	PWM output	$(TSnCMP0 + 1) \times$ count clock	Output an inactive level throughout one period (duty cycle 0%)	$TSnCMPm = TSnCMP (m + 1)$ or $TSnCMP (m + 1) > TSnCMP0$ (m = 1, 3, 5, 7, 9, 11)
			Output an active level of one count clock in one period	$TSnCMPm =$ $TSnCMP (m + 1) + 1$ $TSnCMP (m + 1) =$ $TSnCMPm - 1$ (m = 1, 3, 5, 7, 9, 11)
			Output an inactive level of one count clock in one period	$TSnCMPm =$ $TSnCMP (m + 1) - 1$ $TSnCMP (m + 1) =$ $TSnCMPm + 1$ (m = 1, 3, 5, 7, 9, 11)
			Output an active level throughout one period (duty cycle 100%)	$TSnCMPm > TSnCMP0$ $TSnCMP (m + 1) \leq TSnCMP0$ (m = 1, 3, 5, 7, 9, 11)

Note -: Not available in PWM mode

When only TSnCMP2 is rewritten and TSG2nO1 is output
 (TSnIOC0.TSnTOE1 = 1, TSnIOC2.TSnOL1 = 0)

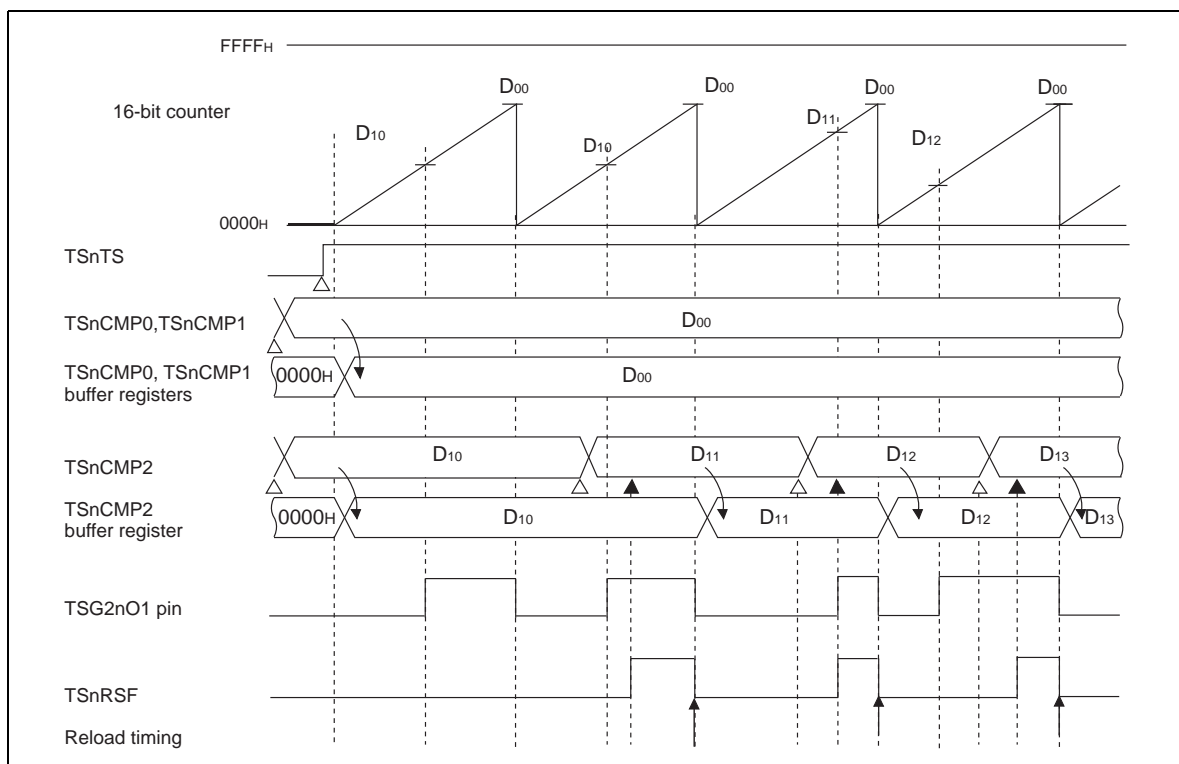

Figure 15-41 Example of Basic Operation Timing of PWM Mode (1/2)

- Note 1. D00: Set values of TSnCMP0 and TSnCMP1 (0000_H - FFFF_H)
 D10, D11, D12 and D13: Set values of TSnCMP2 (0000_H - FFFF_H)
- Note 2. TSG2nO1 (PWM duty cycle) = (TSnCMP1 - TSnCMP2) × count clock
 TSG2nO1 (PWM period) = (TSnCMP0 + 1) × count clock
- Note 3. TSG2nO2 to TSG2nO6 pins behave similarly to the TSG2nO1 pin.
- Note 4. Δ: Write access
- Note 5. ▲: TSnCMP1 write access (equivalent).

When TSnCMP0-TSnCMP2 are rewritten, and TSG2nO1 is output (TSnIOC0.TSnTOE1 = 1, TSnIOC2.TSnOL1 = 0)

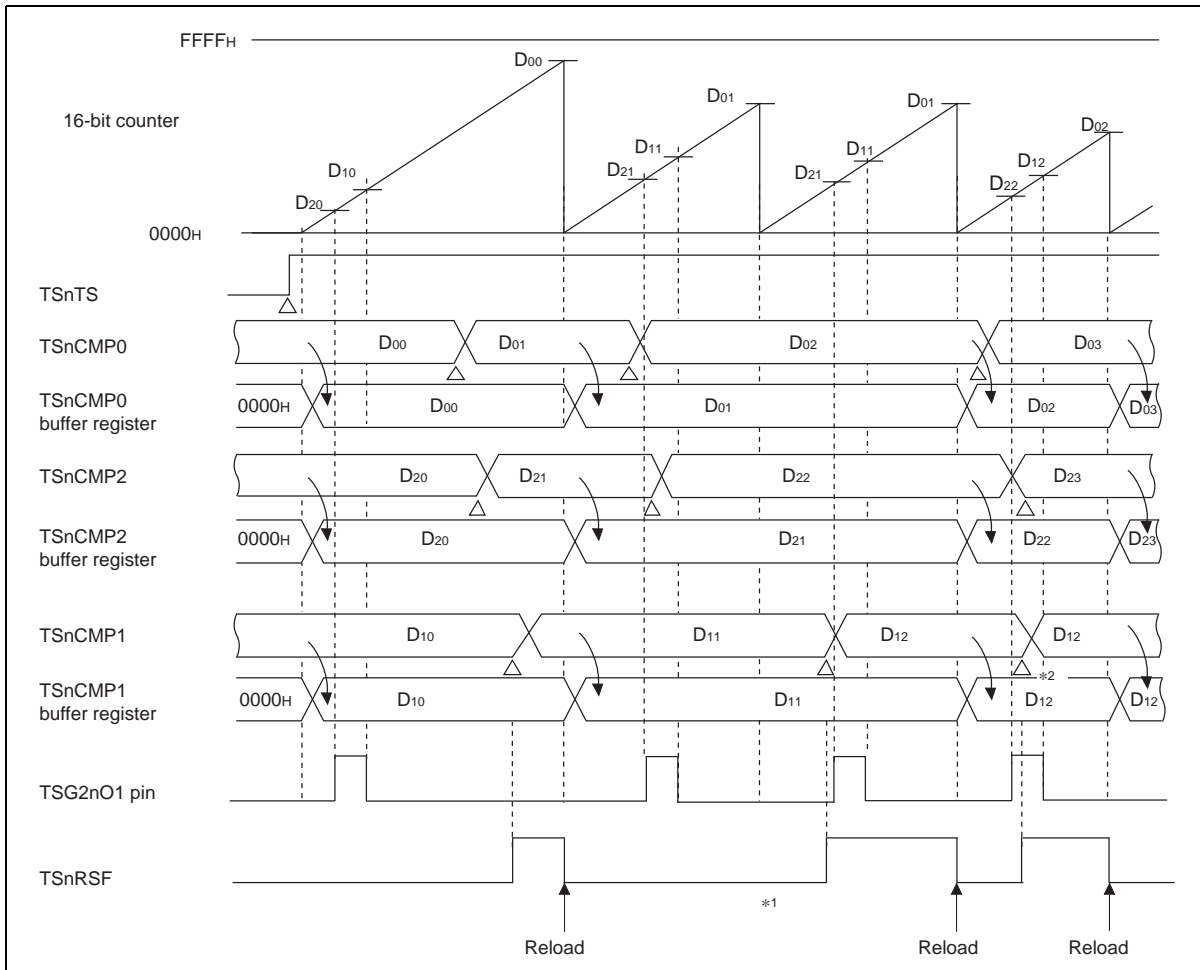

Figure 15-41 Example of Basic Operation Timing of PWM Mode (2/2)

- Note 1. The TSnCMP0 buffer register is not reloaded, because TSnCMP1 register was not rewritten.
- Note 2. Equivalent writing

-
- Note 1. D00, D01, D02, and D03: Set point of TSnCMP0 (0000_H - FFFF_H)
D10, D11, D12, and D13: Set point of TSnCMP1 (0000_H - FFFF_H)
D20, D21, D22, and D23: Set point of TSnCMP2 (0000_H - FFFF_H)

Note 2. Outputs from TSG2nO2 to TSG2nO6 behave similarly to the TSG2nO1 pin.

Note 3. Δ: Write access

(2) Interrupt/Reload Skipping Function in PWM Mode

By setting TSnCTL4.TSnPRE and TSnPIE to 1 and setting the TSnRCC04 to TSnRCC00 and TSnCTL3.TSnRIA, the reload and interrupt skipping function can be used.

By setting TSnPRE to 1 and setting the TSnRCC04 to TSnRCC00, the interrupt skipping function can be used.

(3) Controlling Dead Time in PWM Mode

By setting the TSnDTC0 and TSnDTC1 registers in PWM mode, it is possible to control the dead time. The dead time is controlled according to the switch timing of the TSG2nO1 output, the TSG2nO2 output, the TSG2nO3 output, the TSG2nO4 output, the TSG2nO5 output, and the TSG2nO6 output.

Table 15-54 Dead Time in PWM Mode

Switch Timing	Dead Time
TSG2nO1: High level to low level TSG2nO2: Low level to high level	Value of TSnDTC1 register
TSG2nO2: High level to low level TSG2nO1: Low level to high level	Value of TSnDTC0 register
TSG2nO3: High level to low level TSG2nO4: Low level to high level	Value of TSnDTC1 register
TSG2nO4: High level to low level TSG2nO3: Low level to high level	Value of TSnDTC0 register
TSG2nO5: High level to low level TSG2nO6: Low level to high level	Value of TSnDTC1 register
TSG2nO6: High level to low level TSG2nO5: Low level to high level	Value of TSnDTC0 register

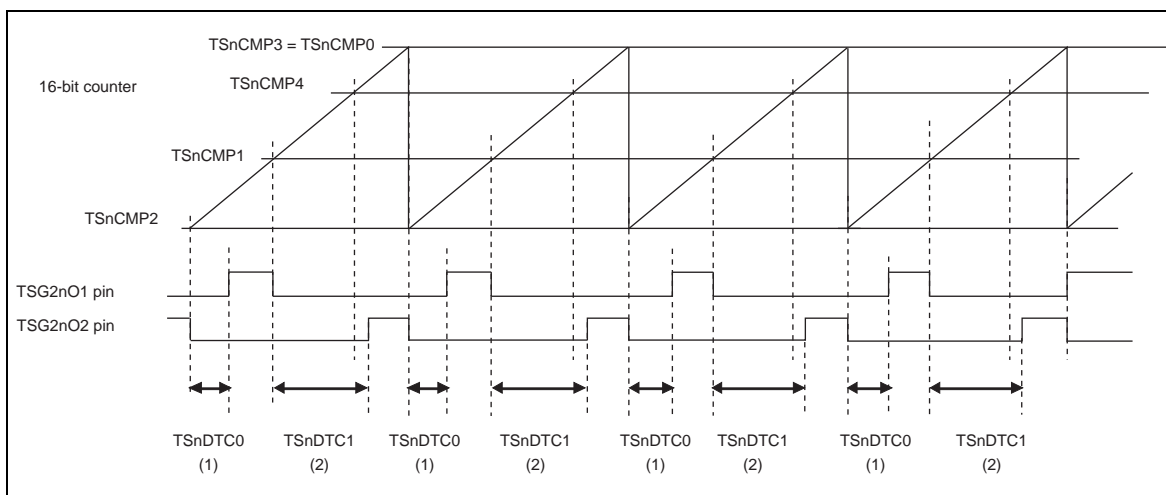

Figure 15-42 Example of Dead Time Control between TSG2nO1 and TSG2nO2 Outputs (1/2)

At (1), the dead time counter starts counting at the falling edge of the TSG2nO2 output. Here, although the 16-bit counter is 0000_H, the TSG2nO1 output stays inactive because the dead time counter is still operating. The TSG2nO1 output becomes active at the timing when the dead time count operation ends.

At (2), the dead time counter starts counting at the falling edge of the TSG2nO1 output. Even after the match of the 16-bit counter and TSnCMP4, the TSG2nO2 output stays inactive because the dead time counter is still operating. The TSG2nO2 output becomes active at the timing when the dead time count operation ends.

-
- Note 1. The TSG2nO1 and TSG2nO2 pin outputs are active high.
 - Note 2. The TSG2nO3 to TSG2nO6 pin outputs behave similarly.
-

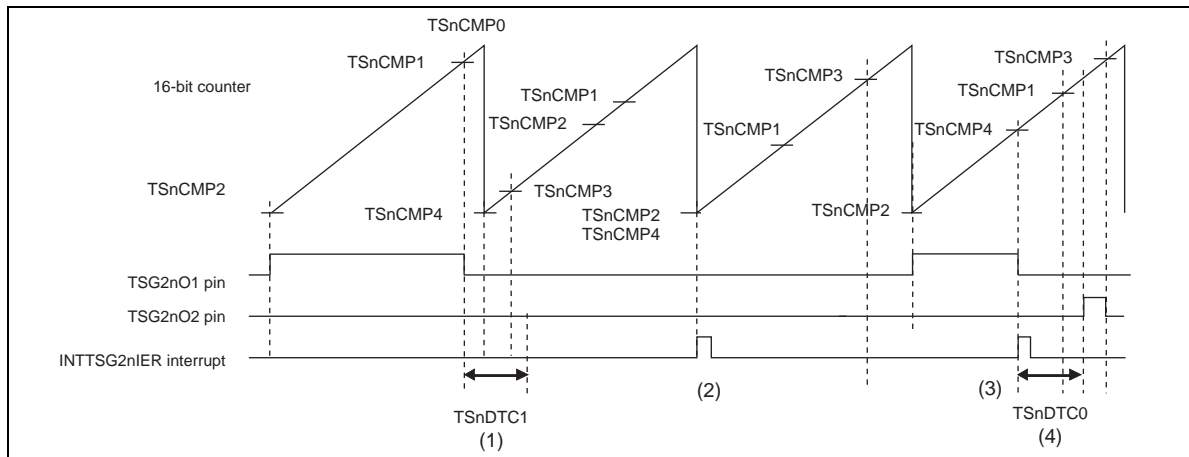

Figure 15-42 Example of Dead Time Control between TSG2nO1 and TSG2nO2 Outputs (2/2)

During (1), the dead time counter starts counting at the falling edge of the TSG2nO1 output. Even after the 16-bit counter reaches 0000_H and the match occurs between the 16-bit counter and

TSnCMP4, the TSG2nO2 output stays inactive because the dead time counter is still operating. Moreover, since the TSnCMP3 register compare match occurs before the operation of the dead time counter ends, the TSG2nO2 output stays inactive.

$TSnCMP1 + TSnDTC1 \geq TSnCMP0 + TSnCMP2$ (TSG2nO2 stays inactive)

$TSnCMP2 + TSnDTC0 \geq TSnCMP0 + TSnCMP1$ (TSG2nO1 stays inactive)

At (2), the INTTSG2nIER interrupt occurs because the TSnCMP2 register and the TSnCMP4 register are set so that the TSG2nO1 and TSG2nO2 outputs rise simultaneously. Here, the TSG2nO1 output and the TSG2nO2 output are inactive.

At (3), compare match with the TSnCMP4 register generates an INTTSG2nIER interrupt and both TSG2nO1 and TSG2nO2 outputs become inactive.

At (4), the falling edge (inactive) of the TSG2nO1 output is caused by the simultaneous active state detected and the dead time counter starts counting. After the end of the dead time counter operation, the TSG2nO2 output becomes active.

Note 1. TSG2nO1 and TSG2nO2 are set to active high.

Note 2. The TSG2nO3 to TSG2nO6 pin outputs behave similarly.

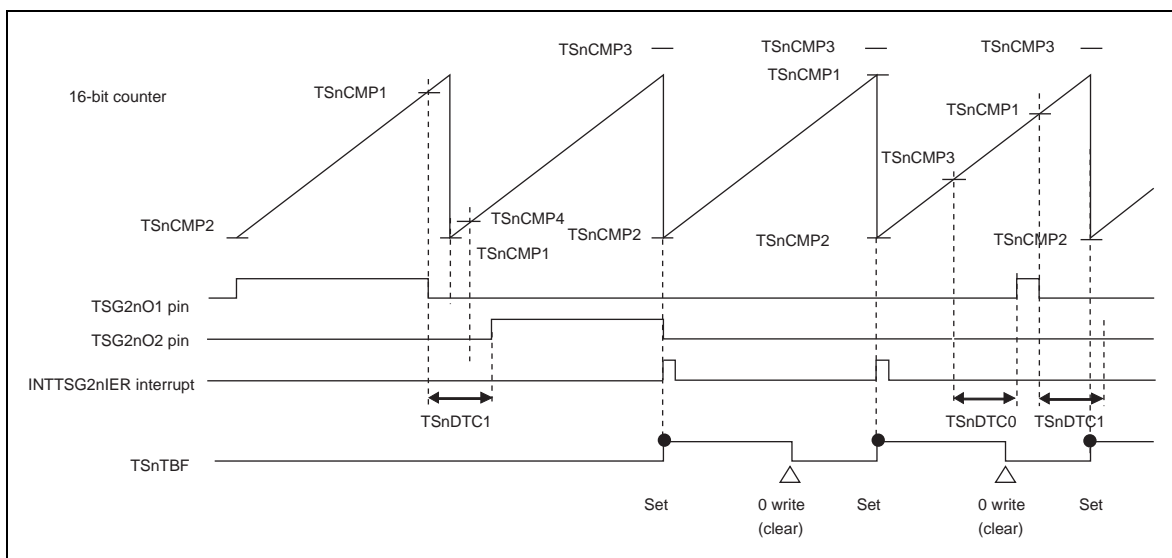

Figure 15-43 Example of 100% Duty Output at Dead Time Control

When the TSG2nO2 pin is set to duty cycle of 100% ($TSnCMP3 \geq TSnCMP0 + 1$), the output of the TSG2nO1 pin is fixed to a low level. This control is intended to mask the active condition of TSG2nO1 output since the TSG2nO2 output is active before the TSG2nO1 output becomes active. In this case, the INTTSG2nIER interrupt is also generated because TSG2nO1 and TSG2nO2 outputs become high simultaneously.

-
- Note 1. TSG2nO1 and TSG2nO2 are set to active high.
 - Note 2. The TSG2nO3 to TSG2nO6 pin outputs behave similarly.
-

(4) Dead Time Rewriting during Timer Operation in PWM Mode

In PWM mode, it is possible to rewrite TSG2n dead time setting registers TSnDTC0 and TSnDTC1 while counting. The new settings are active at reload timing. It is not possible to change the dead time setting by rewriting at anytime.

Please enable reloading by writing to the TSnCMP1 register.

15.11.2 HT-PWM Mode (High accuracy Triangular - Pulse Width Modulation Mode)

Overview In this mode, the 16-bit counter (up/down count by ± 2 bits, practically 15 bits) and the 16-bit compare registers (LSB is used to control additional pulse) are used to generate a 6-phase PWM signal.

- Prerequisites**
- Set the carrier wave period to TSnCMP0.
 - Set the duty cycle of the voltage data signals of the U phase, V phase, and W phase with TSnCMPU, TSnCMPV, and TSnCMPW (The values set to TSnCMPU, TSnCMPV, and TSnCMPW are reflected immediately to the corresponding TSnCMPm (m = 1, 2, 5, 6, 9, 10)).
 - Symmetric triangular wave control is described in this section. Please refer to 15.11.2 (10) Asymmetric Triangular Wave Control in HT-PWM Mode, for asymmetric triangular wave control.

Functional description Set the period of carrier wave and the duty cycle of the U phase, the V phase, and the W phase. Counting up begins when TSnTRG0.TSnTS is set to 1.

The 16-bit counter counts up from TSnDTC0 as the minimum value, and counts down upon the match of the maximum value of TSnCMP0 + TSnDTC0.

The dead time is set with TSnDTC0 and TSnDTC1. TSnDTC0 sets the dead time of inverse phase (OFF) to positive phase (ON) switch and TSnDTC1 sets the dead time of positive phase (OFF) to inverse phase (ON) switch. The 10-bit counters (TSnDTT1 to TSnDTT3) for dead time generation load the set values of TSnDTC0 and TSnDTC1 by the compare match of the 16-bit counter and the TSnCMPm buffer register (m = 1, 2, 5, 6, 9, 10), and start down-counting.

The INTTSG2nIm interrupts (m = 01, 02, 05, 06, 09, 10) are generated by the compare match of the 16-bit counter with TSnCMP1, TSnCMP2, TSnCMP5, TSnCMP6, TSnCMP9, and the TSnCMP10 buffer registers.

Note The HT-PWM mode is enabled when TSnTRG0.TSnMD1 and TSnMD0 = 01_B.

(1) Block Diagram and Basic Timing Chart

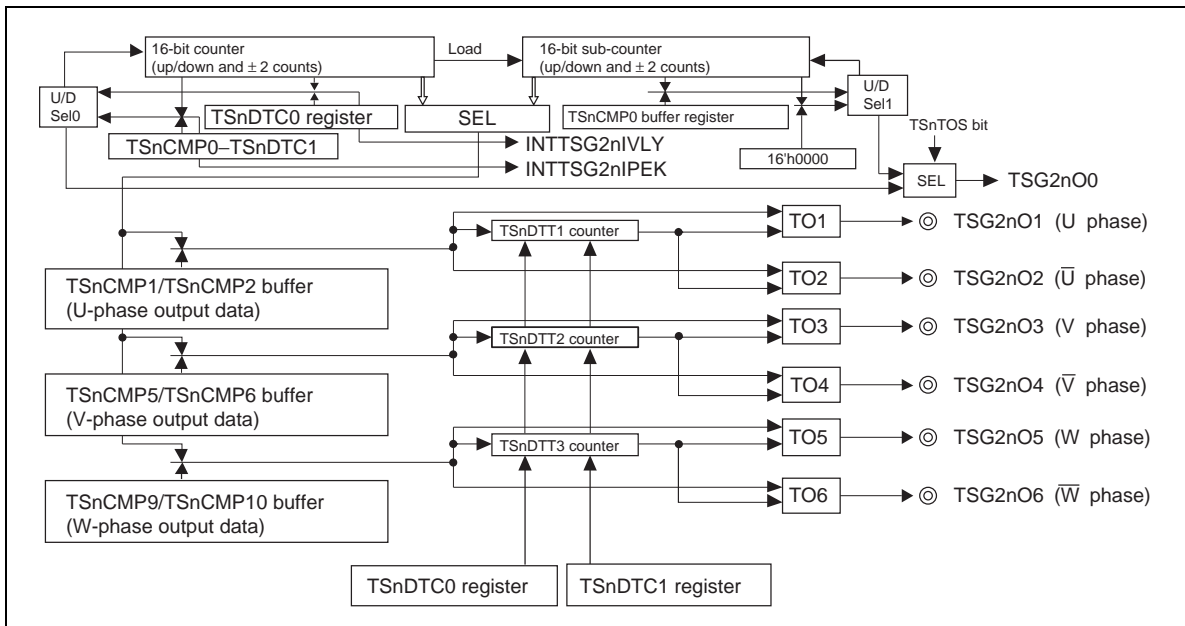

Figure 15-44 Block Diagram in HT-PWM Mode

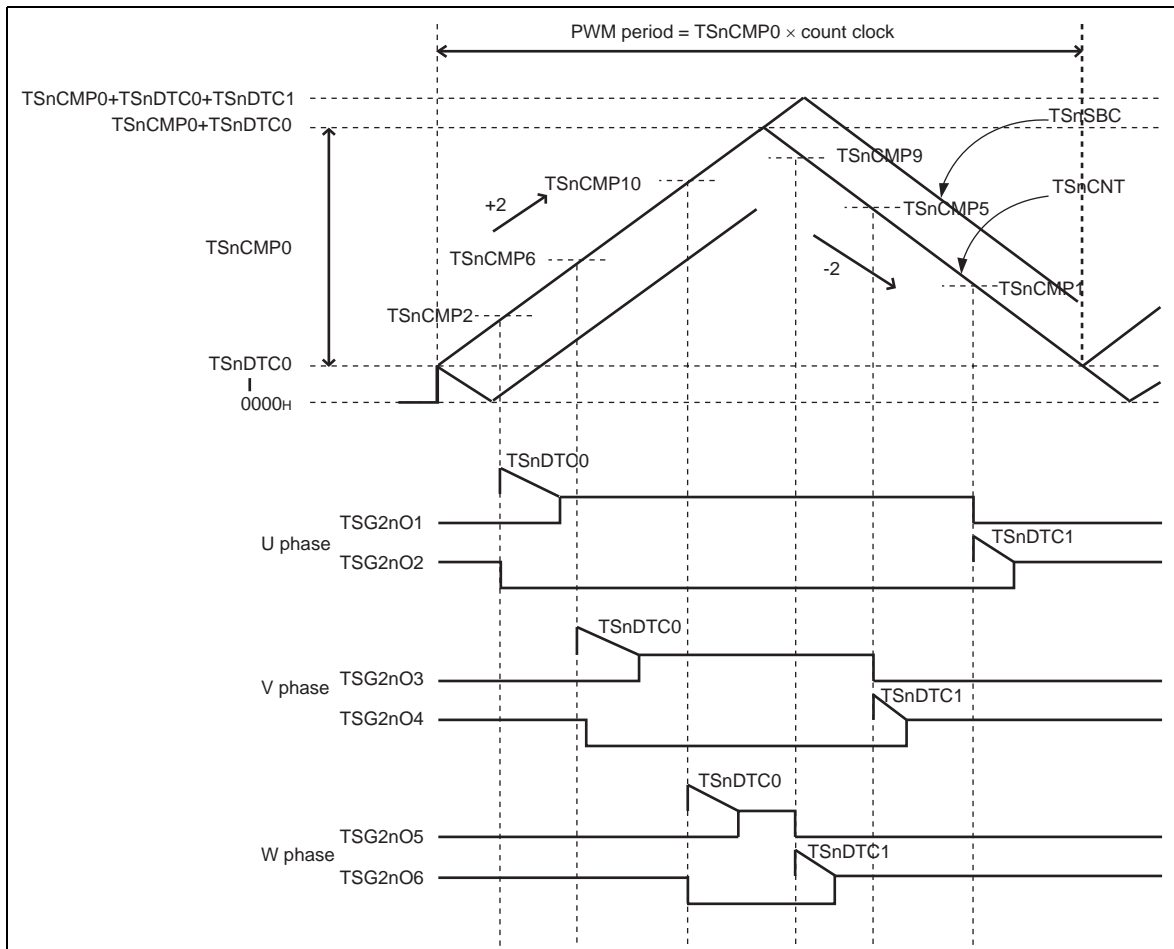

Figure 15-45 Basic Timing in HT-PWM Mode

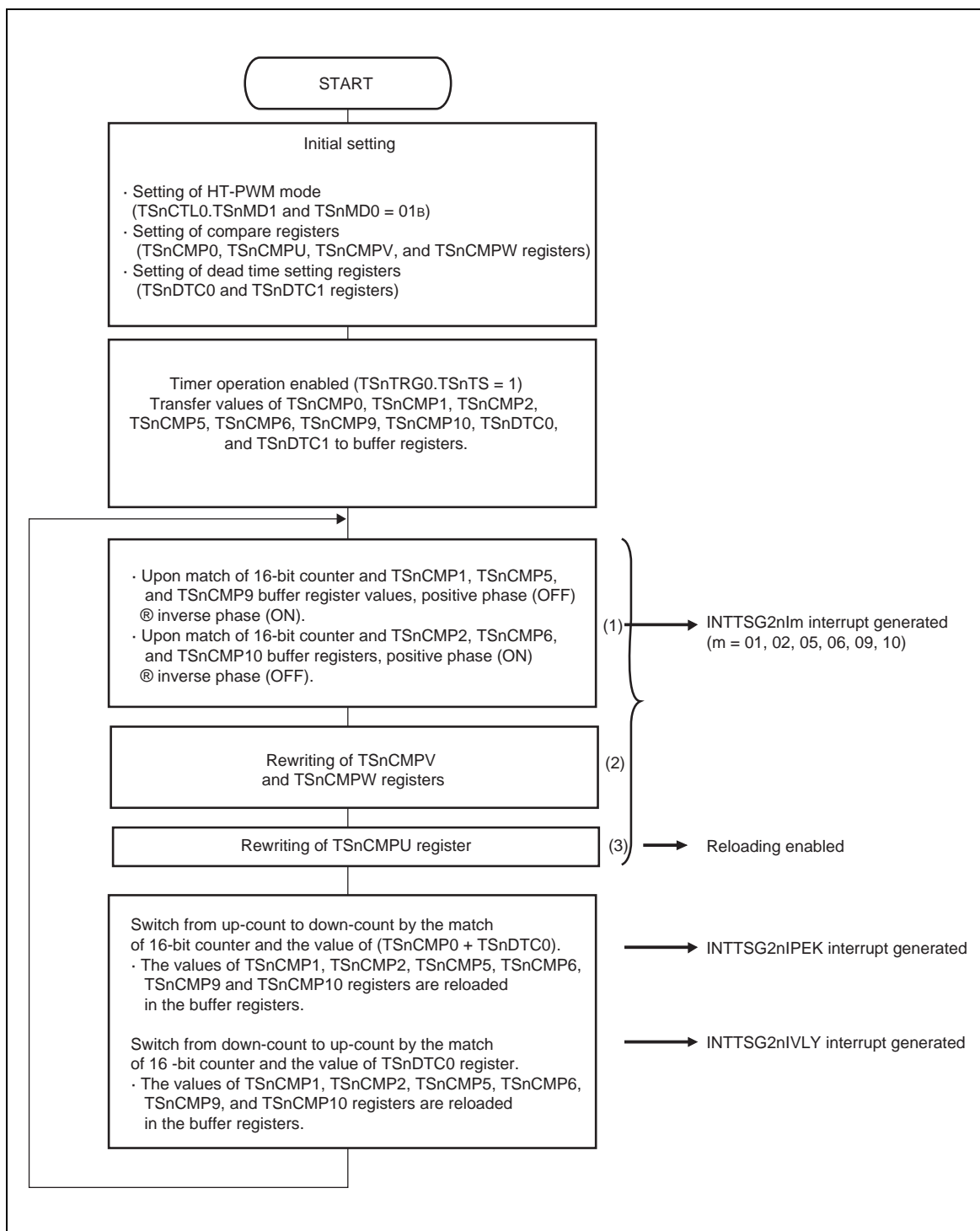

Figure 15-46 Basic Operation Flow in HT-PWM Mode

- Note
- Write access to TSnCMPU (TSnCMP1) includes reloading enabling operation. Therefore, (3) must be done after (2).
 - The INTTSG2nIPEK interrupt is generated only when TSnCTL4.TSnPRE = 1.
 - The INTTSG2nIVLY interrupt is generated only when TSnCTL4.TSnVRE = 1.

(2) List of HT-PWM Mode Operations

Table 15-55 Counter Function in HT-PWM Mode

Operation		Setting Condition
16-bit counter	Start	TSnTRG0.TSnTS = 0 → 1 (up count from TSnDTC0)
	Up count	Compare match of TSnDTC0 buffer register and 16-bit counter
	Down count	Compare match of TSnCMP0 + TSnDTC0 and 16-bit counter
	Clear	-
	Stop	TSnTRG1.TSnTT = 0 → 1
16-bit sub-counter	Start	TSnTRG0.TSnTS = 0 → 1 (down count from TSnDTC0)
	Up count	Underflow
	Down count	Compare match of TSnCMP0 + TSnDTC0 + TSnDTC1 buffer register and 16-bit sub-counter
	Load	<ul style="list-style-type: none"> TSnCMP0 + TSnDTC0: When value of 16-bit counter matches the value of buffer register TSnCMP0 + TSnDTC0 TSnDTC0: When value of 16-bit counter matches the value of the buffer register TSnDTC0
	Clear	-
	Stop	TSnTRG1.TSnTT = 0 → 1

Table 15-56 Compare Register and Dead Time Setting Register Functions in HT-PWM Mode

Register	Rewrite Method	Rewrite during Operation	Function
TSnCMP0	Reload/Anytime rewrite	Possible	Setting period
TSnCMPU	-	Possible	PWM control for U phase
TSnCMP1W (TSnCMP1, TSnCMP2)	Reload/Anytime rewrite		
TSnCMPV	-	Possible	PWM control for V phase
TSnCMP5W (TSnCMP5, TSnCMP6)	Reload/Anytime rewrite		
TSnCMPW	-	Possible	PWM control for W phase
TSnCMP9W (TSnCMP9, TSnCMP10)	Reload/Anytime rewrite		
TSnDCMP0W, TSnDCMP2	Reload/Anytime rewrite	Possible	Diagnostic signal output or A/D conversion trigger
TSnDTC0, TSnDTC1	Reload	Possible conditionally	Period and dead time setting

- Note
- The values written to TSnCMPU, TSnCMPV, and TSnCMPW registers are set to both the lower and upper 16-bits of the respective TSnCMP1W (TSnCMP1, TSnCMP2), TSnCMP5W (TSnCMP5, TSnCMP6), and TSnCMP9W (TSnCMP9, TSnCMP10) registers.
 - Please refer to (8) (a) TSnDTC0 and TSnDTC1 Rewriting, on how to rewrite the TSnDTC0 and TSnDTC1.

Table 15-57 Timer Output Function in HT-PWM Mode

Pin	Function
TSG2nO0	Active level output during up count, inactive level output at down count of the 16-bit counter/sub-counter
TSG2nO1	PWM output with dead time by compare match of TSnCMP1 buffer register and 16-bit counter (down count) and compare match of TSnCMP2 buffer register and 16-bit counter (up count)
TSG2nO2	Inverse phase output to TSG2nO1
TSG2nO3	PWM output with dead time by compare match of TSnCMP5 buffer register and 16-bit counter (down count) and compare match of TSnCMP6 buffer register and 16-bit counter (up count).
TSG2nO4	Inverse phase output to TSG2nO3
TSG2nO5	PWM output with dead time by compare match of TSnCMP9 buffer register and 16-bit counter (down count) and TSnCMP10 buffer register and 16-bit counter (up count).
TSG2nO6	Inverse phase output to TSG2nO5
TSG2nO7	Diagnostic signal output or pulse output by A/D conversion trigger

Note State of TSG2nO0 output can be switched with TSnIOC1.TSnTOS.

Table 15-58 Interrupt Request in HT-PWM Mode

Interrupt	Function
INTTSG2nI00	Compare match of TSnDTC0 buffer register and 16-bit counter (periodic interrupt)
INTTSG2nIm (m = 01, 02, 05, 06, 09, 10)	Compare match of TSnCMPm buffer register and 16-bit counter
INTTSG2nIER	Error interrupt
INTTSG2nIVLY	Valley interrupt
INTTSG2nIPEK	Peak interrupt
INTTSG2nIWN	Warning interrupt

Table 15-59 Compare Match Timing in HT-PWM Mode

Compare Match	Timing
TSnCMP0	When 16-bit counter changes from TSnCMP0 + TSnDTC0 to TSnCMP0 + TSnDTC0 - 2
TSnCMPm (m = 1, 2, 5, 6, 9, 10)	When 16-bit counter changes from TSnCMPm to TSnCMPm ± 2 (m = 1, 2, 5, 6, 9, 10)

Table 15-60 Example of Setting Each Timer Output Condition in HT-PWM Mode

Pin	Item	Output Period	Output Duty	
			Output Condition	Setting Condition
TSG2nO0	Toggle output	TSnCMP0 × count clock	Output an active level during up count, and an inactive level during down count	-
TSG2nO1, TSG2nO3, TSG2nO5	PWM output	TSnCMP0 × count clock	Output an inactive level throughout one period (0% duty)	TSnCMPm = TSnCMP0 + TSnDTC0 + TSnDTC1 (m = U, V, W)
			Output an active level of one count clock in one period	TSnCMPm = TSnCMP0 - 1 (m = U, V, W)
			Output an inactive level of one count clock in one period	TSnCMPm = 0001 _H (m = U, V, W)
			Active level during all period (100% duty)	TSnCMPm = 0000 _H (m = U, V, W)
TSG2nO2, TSG2nO4, TSG2nO6	PWM output	TSnCMP0 × count clock	Inactive level during all period (0% duty)	TSnCMPm = 0000 _H (m = U, V, W)
			Output an active level of one count clock in one period	TSnCMPm = TSnDTC0 + TSnDTC1 + 1 (m = U, V, W)
			Output an inactive level of one count clock in one period	TSnCMPm = TSnCMP0 + TSnDTC0 + TSnDTC1 - 1 (m = U, V, W)
			Active level during all period (100% duty)	TSnCMPm = TSnCMP0 + TSnDTC0 + TSnDTC1 (m = U, V, W)
TSG2nO7	Diagnostic signal output or pulse output by A/D conversion trigger	TSnCMP0 × count clock	Please refer to Section 15.9, A/D Conversion Trigger Function.	

(3) Various Settings of HT-PWM Mode

- Mode Setting** HT-PWM can be used when TSnCTL0.TSnMD1 and TSnMD0 is set to 01_B.
- Setting timer output** The output pins TSG2nO1 to TSG2nO6 are controlled by setting TSnIOC0, TSnIOC2, and TSnIOC3.
- The output pin TSG2nO0 indicates the up/down count status of the 16-bit counter or the 16-bit sub-counter. Switch between the 16-bit sub-counter and the 16-bit counter is done with the TSnIOC1.TSnTOS bit.
- The TSG2nO7 pin outputs pulses of the diagnostic output or the A/D conversion trigger. Please set it as required.
- Enabling error interrupt generation** Error interrupt (INTTSG2nIER) due to the detection of the simultaneous active state of the positive phase and inverse phase is enabled by setting TSnIOC1.TSnEOC to 1. In HT-PWM mode, with any value set in the compare register, the simultaneous active state of the positive phase and inverse phase is not possible. Please refer for to Section 15.10, Error/Warning Interrupt, for details.
- Setting register rewriting timing with reload function** With TSnCTL3.TSnRMC, reload (simultaneous rewrite) or rewrite (anytime) is specified for the registers with reload function. The default setting is 0 (reload). To reload, set TSnCTL4.TSnPRE or TSnVRE to 1.
- The reload timing is not generated if both the TSnPRE bits and TSnVRE bits are set to 0.
- When "anytime rewrite" is specified, the unintended output may be generated depending on the rewrite timing.
- Setting interrupts and skipping function** Interrupts and the skipping function are set with TSnCTL4. TSnPIE should be set to 1 when peak interrupt (INTTSG2nIPEK) is necessary and TSnVIE to 1 when valley interrupt (INTTSG2nIVLY) is necessary. To use the skipping function for peak/valley interrupts, the TSnRCC4 to TSnRCC0 must be set.

Setting A/D conversion trigger output

To set A/D conversion trigger 0 (TSnADTRG0 signal), use TSnCTL5.TSnAT09 to TSnAT00.

With TSnAT09 to TSnAT00, A/D conversion trigger output is enabled or disabled at the match of 16-bit counter (during up count) with TSnDCMP2 to TSnDCMP0, the match of the 16-bit counter (during down count) with TSnDCMP2 to TSnDCMP0, the 16-bit counter peak interrupt (INTTSG2nIPEK), the 16-bit counter valley interrupt (INTTSG2nIVLY), the 16-bit sub-counter peak timing, and 16-bit sub-counter valley timing.

To set A/D conversion trigger 1 (TSnADTRG1 signal), use TSnCTL6.TSnAT19 to TSnAT10.

To set the match timing of 16-bit counter and TSnDCMP2 to TSnDCMP0, set the compare value to the pertinent register.

The skipping function can be used for TSnADTRG0 and the TSnADTRG1 signals. Use TSnACC00, TSnACC01 of TSnCTL5, TSnACC10, and TSnACC11 of TSnCTL6 to select the skipping rate among 1/1, 1/2, 1/4, and 1/8.

Caution Set TSnCTL5, TSnCTL6, and TSnDCMP2 to TSnDCMP0 correctly when using the TSG2nO7 output for the A/D conversion trigger timing pulse.

Setting dead time

The dead time can be set with TSnDTC0 and TSnDTC1.

The dead time is calculated by the following expressions:

$$\text{PCLK} \times \text{TSnDTC0}$$

$$\text{PCLK} \times \text{TSnDTC1}$$

TSnDTC0 can set the time between a change of TSG2nO2, TSG2nO4, and TSG2nO6 to the inactive state and a change of TSG2nO1, TSG2nO3, and TSG2nO5 to the active state, respectively.

TSnDTC1 can set the time between a change of TSG2nO1, TSG2nO3, TSG2nO5 to the inactive state and a change of TSG2nO2, TSG2nO4, and TSG2nO6 to the active state, respectively.

TSnDTC0 and TSnDTC1 can only be set to an even value.

Carrier period Set the carrier period with TSnCMP0 according to the following expression:

$$\text{TSnCMP0} = \text{Carrier period} / \text{count clock period (PCLK)}$$

Satisfy the following requirements when setting the TSnCMP0 register regarding the dead time:

- $\text{TSnCMP0} + \text{TSnDTC0} + \text{TSnDTC1} \leq \text{FFFE}_{\text{H}}$
- $\text{TSnCMP0} > \text{TSnDTC0}$
- $\text{TSnCMP0} > \text{TSnDTC1}$
- $\text{TSnCMP0} > 3 \times \text{MAX}(\text{TSnDTC0}, \text{TSnDTC1})$
- TSnCMP0: Even number

Note MAX (A, B) indicates the larger value of A and B.

Duty (PWM width) setting The duty of the U phase, the V phase, and the W phase is set with TSnCMPm (m = U, V, W, or 1, 2, 5, 6, 9, and 10), respectively. The setting range of the compare registers is as follows:

$$0000_{\text{H}} \leq \text{TSnCMPm} \leq \text{TSnCMP0} + \text{TSnDTC0} + \text{TSnDTC1}$$

LSB (least significant bit) of TSnCMPU, TSnCMPV, and TSnCMPW indicates the setting of an additional pulse. When TSnCMPU = 0003_H, the change in the inverse phase (TSG2nO2 output) is done one count clock later compared to the TSnCMPU = 0002_H setting (when the 16-bit counter is up-counting). The additional pulse cannot be set to TSnCMP1, TSnCMP2, TSnCMP5, TSnCMP6, TSnCMP9, or TSnCMP10 (only even numbers can be set to these registers).

(4) 16-Bit Counter Operation in HT-PWM Mode

The 16-bit counter is initialized to 0000_H and the value of TSnDTC0 is loaded immediately after starting the TSG2n timer operation (TSnTRG0.TSnTS = 1). Afterwards, counting is done by +2. After 16-bit counter reaches the value of TSnCMP0 + TSnDTC0, counting is done by -2.

Figure 15-84 shows 16-bit counter operation.

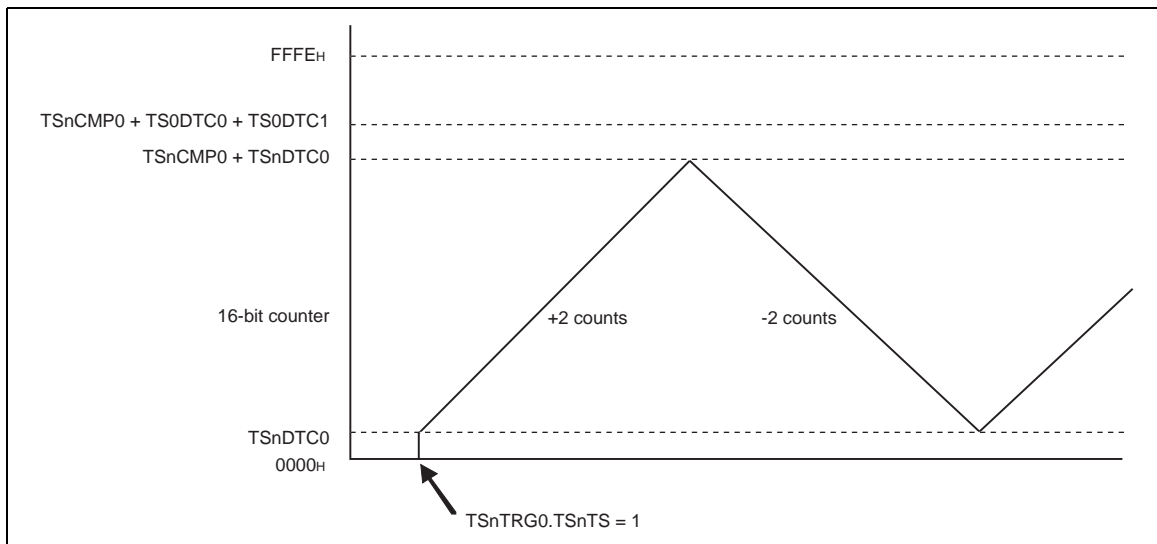

Figure 15-47 Example of 16-Bit Counter Operation in HT-PWM Mod

Note Minimum 16-bit counter value: TSnDTC0
 Maximum 16-bit counter value: TSnCMP0 + TSnDTC0
 Carrier period: TSnCMP0 x count clock period (PCLK)

The 16-bit sub-counter is initialized to 0000_H and the value of TSnDTC0 is loaded immediately after starting the TSG2n timer operation (TSnTRG0.TSnTS = 1). Afterwards, counting by -2 is done until 0000_H is reached and counting by +2 begins. Next, the value of the 16-bit counter is loaded into the 16-bit sub-counter at a change timing of the 16-bit counter into the down count. Counting up by the 16-bit sub-counter continues until the value reaches the value of TSnCMP0 + TSnDTC0 + TSnDTC1, and then counting by -2 begins. Similarly, when the 16-bit counter value matches the TSnDTC0 value, the 16-bit counter value is loaded to the 16-bit sub-counter and the down count is continued.

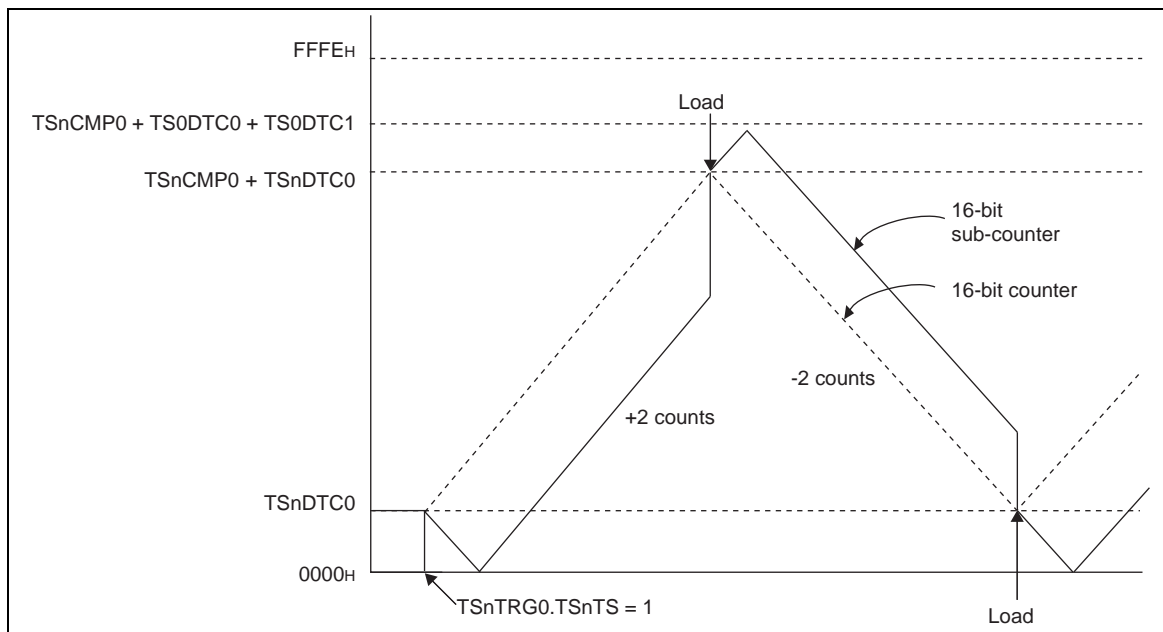

Figure 15-48 Example of 16-bit Sub-Counter Operation in HT-PWM Mode

Note Minimum 16-bit sub-counter value: 0000_H
 Maximum 16-bit sub-counter value: TSnCMP0 + TSnDTC0 + TSnDTC1

(5) Basic Operation of HT-PWM Mode

(a) Example of Timer Output Immediately after the Start of the TSG2n Timer Operation

Figure 15-51 shows the timing chart when $TSnCMP0 = 000E_H$, $TSnDTC0 = 0002_H$, $TSnDTC1 = 0004_H$ and $TSnCMPU = 0000_H-0014_H$ (excerpt). In this example, $TSnIOC2.TSnOL1 - TSnOL6 = 000000_B$.

In the case of $TSnCMPU = TSnDTC0$, when the initial value of the counter is loaded after TSG2n begins operation ($TSnTRG0.TSnTS = 1$), the TSG2nO2 output is changed to the active level. When $TSnCMPU = TSnDTC0-0001_H$, an additional pulse is generated, the TSG2nO2 output is changed one count clock cycle later compared to the case of $TSnCMPU = TSnDTC0-0002_H$.

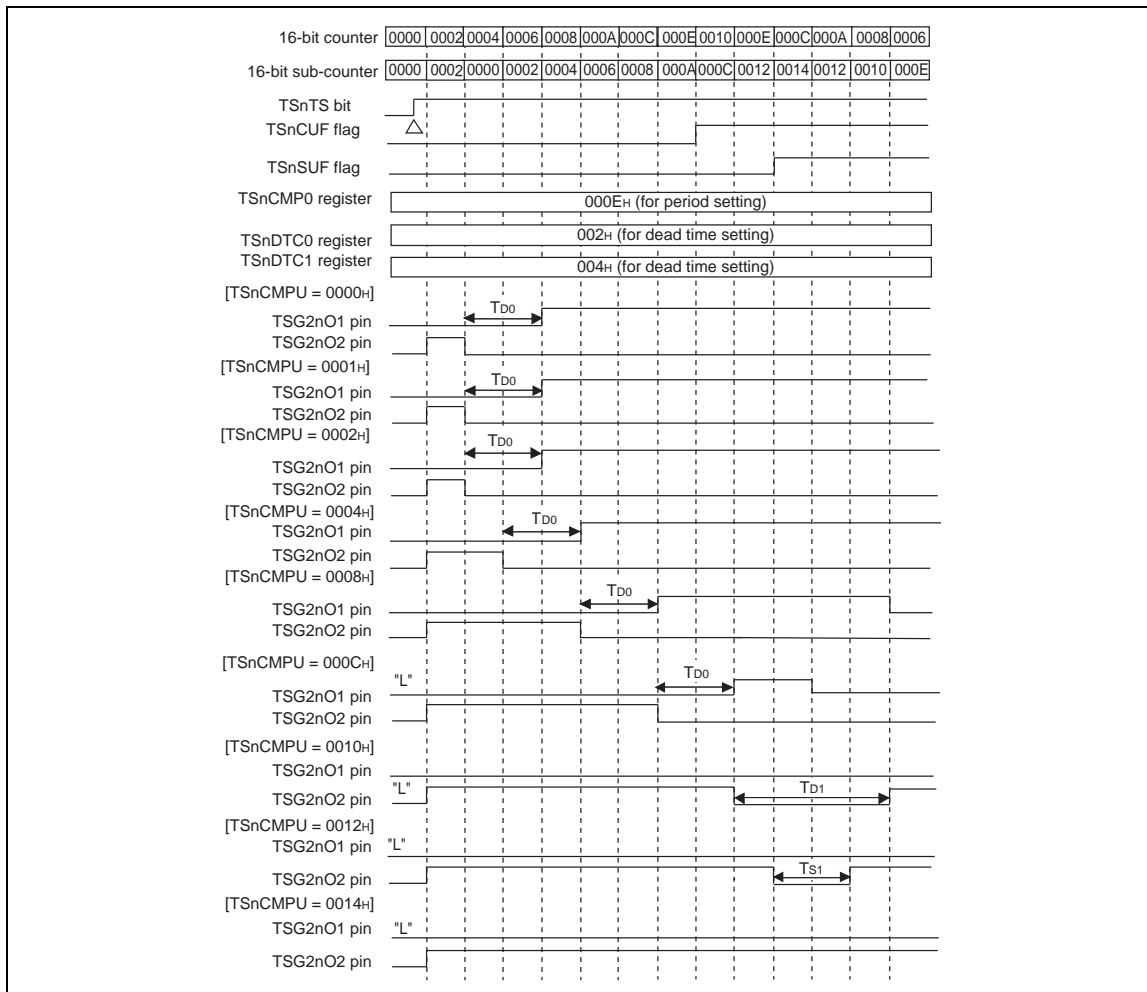

Figure 15-49 Example of Timer Output when TSnTS is Set to 1 (Initial) in HT-PWM Mode

- Note 1. $TSnCMP0 = 000E_H$, $TSnDTC0 = 0002_H$, $TSnDTC1 = 0004_H$
- Note 2. T_{D0} : Time depending on setting of the dead time in the TSnDTC0 register
 T_{D1} : Time depending on setting of the dead time in the TSnDTC1 register
 T_{S1} : Time decided by compare match of the 16-bit sub-counter and TSnCMPU register, when $TSnCMPU > 16\text{-bit counter maximum value}$
- Note 3. Δ : Write access

(b) Example of Timer Output during TSG2n Timer Operation

The figure below shows the timing chart when $TSnCMP0 = 000E_H$, $TSnDTC0 = 0002_H$, $TSnDTC1 = 0004_H$, and $TSnCMPU$ is set to 0000_H-0014_H (excerpt). In this example, $TSnIOC2.TSnOL1-TSnOL6 = 000000_B$.

The range of the active (high level) width of a positive phase (TSG2nO1) output is $0000_H \leq TSnCMPU \leq TSnCMP0$ (for the additional pulse). The range of the active (high level) width of an inverse phase (TSG2nO2) output is $TSnDTC0 + TSnDTC1 \leq TSnCMPU \leq TSnCMP0 + TSnDTC0 + TSnDTC1$.

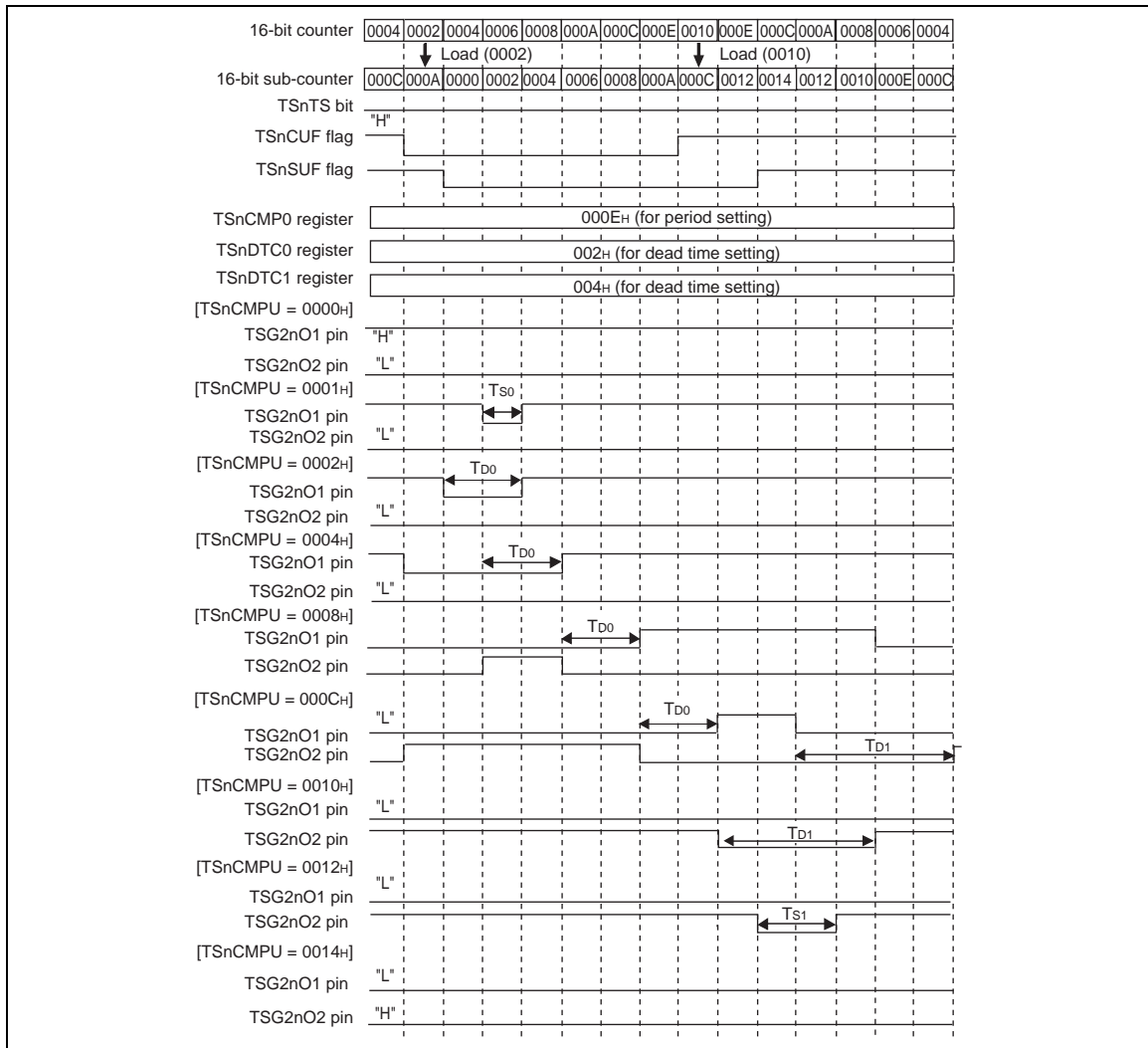

Figure 15-50 Example of Timer Output during TSG2n Operation in HT-PWM Mode

- Note 1. $TSnCMP0 = 000E_H$, $TSnDTC0 = 0002_H$, $TSnDTC1 = 0004_H$
 Note 2. T_{D0} : Time depending on setting of the dead time in the $TSnDTC0$ register
 T_{D1} : Time depending on setting of the dead time in the $TSnDTC1$ register
 T_{S0} : Time decided by compare match of 16-bit sub-counter and the $TSnCMPU$ register, when $TSnCMPU < 16\text{-bit counter minimum value}$
 T_{S1} : Time decided by compare match of the 16-bit sub-counter and the $TSnCMPU$ register, when $TSnCMPU > 16\text{-bit counter maximum value}$

(6) Additional Pulse Control in HT-PWM Mode

The HT-PWM mode can generate an additional pulse by setting 1 to the LSB of the duty setting registers (TSnCMPU, TSnCMPV, and TSnCMPW). This allows more precise control of the pulse duty than standard pulse control.

The following sections describe two examples of pulse output of TSG2nO1: additional pulse control is used in one example and additional pulse control is not used in another.

(a) Example of Pulse Output when Additional Pulse Control Is Used

Figure 15-51 shows the additional pulse control when an odd value is set to TSnCMPU.

The arrows and numerical values show the width of the duty cycle of the TSG2nO1 output in one period.

When the additional pulse control is used as shown in Figure 15-51, the width of the output of the TSG2nO1 (duty cycle) can be set within a range from the width of 12 clock cycles to the width of 0 clock cycles in one-clock-cycle step.

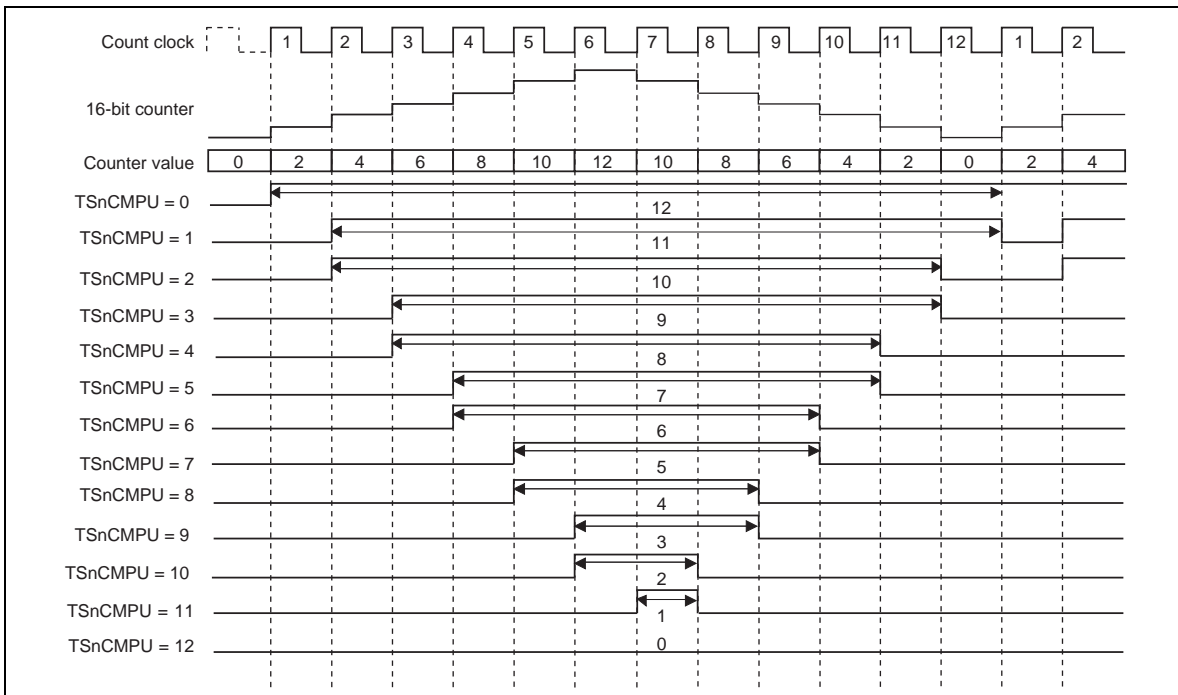

Figure 15-51 Example of TSG2nO1 Output when Additional Pulse Control Is Used in HT-PWM Mode

Note TSnCMP0 = 12, TSnDTC0 = 0, TSnDTC1 = 0

(b) Example of Pulse Output when Additional Pulse Control Is Not Used

The arrows and numerical values in Figure 15-52 show the width of the duty cycle of the TSG2nO1 output in one period.

When the additional pulse control is not used, the width of the TSG2nO1 output can be set within a range from the width of 12 clock cycles to the width of 0 clock cycles in two-clock-cycle step. In this case, the change in duty cycle is larger than that in the case when the additional pulse control is used.

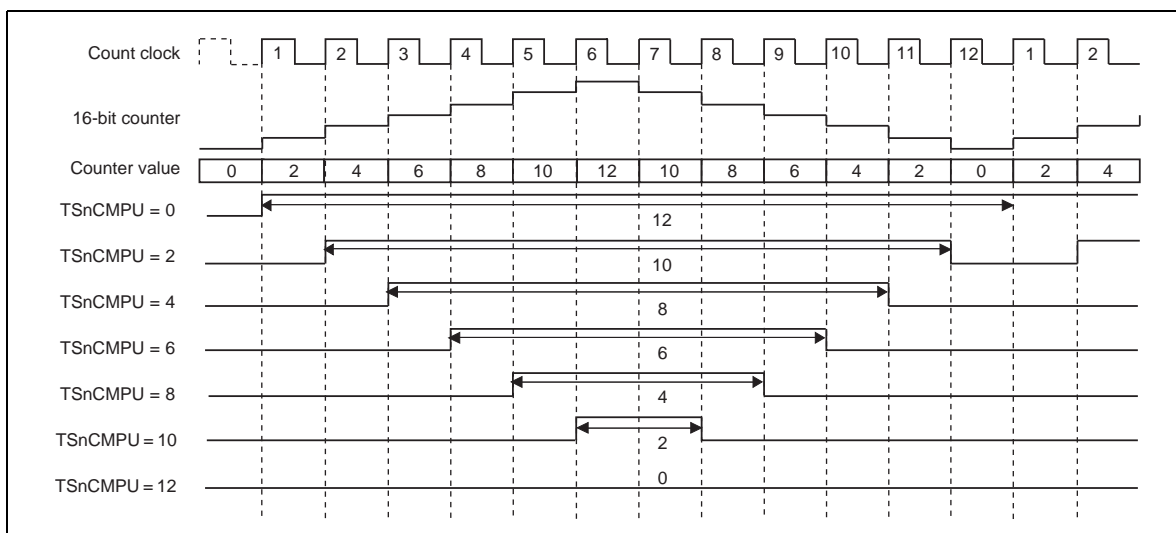

Figure 15-52 Example of Output when Additional Pulse Control Is Not Used in HT-PWM Mode

Note TSnCMP0 = 12, TSnDTC0 = 0, TSnDTC1 = 0

(7) Dead Time Control in HT-PWM Mode

Duty setting registers are TSnCMP1, TSnCMP2, TSnCMP5, TSnCMP6, TSnCMP9, and TSnCMP10 and registers for setting the period are TSnCMP0, TSnDTC0, and TSnDTC1 in HT-PWM mode. The 6-phase PWM waveform of a variable duty is output by using these registers. To achieve the dead time control, there are two dead time setting registers (TSnDTC0 and TSnDTC1) and six 10-bit down counters that operate synchronously with the count clock of the 16-bit counter. TSnDTC0 is used for setting a dead time from a change of the inverse phase to the inactive state to a change of the positive phase to the active state. TSnDTC1 is used for setting a dead time from a change of the positive phase to the inactive state to a change of the inverse phase to the active state.

Figure 15-53 shows the output waveform when TSnDTC0 = x and TSnDTC1 = y.

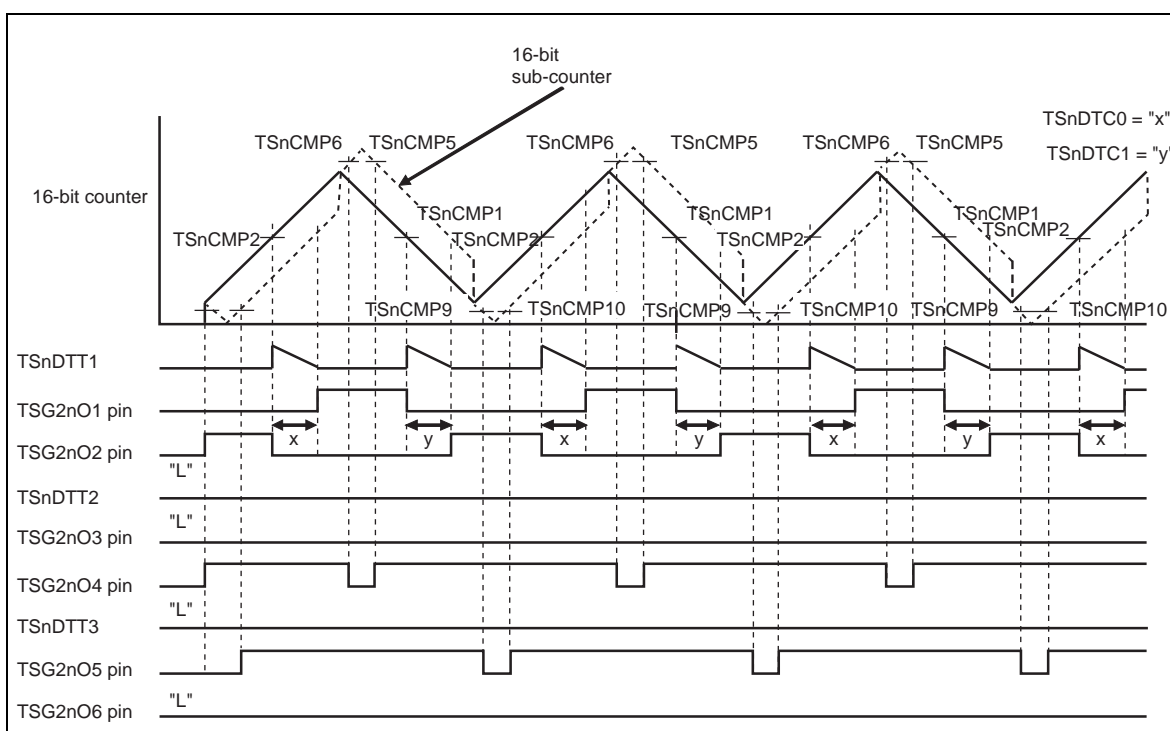
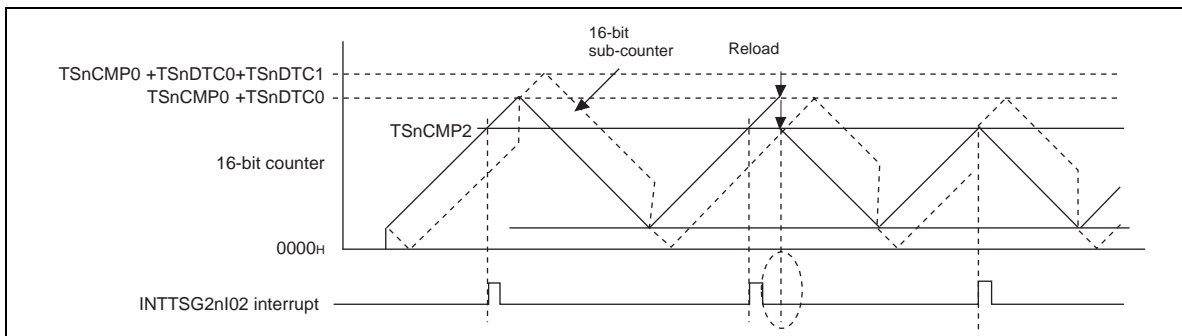

Figure 15-53 Example of Output Waveform with Dead Time in HT-PWM Mode

(8) Notes Concerning Dead Time Control in HT-PWM Mode**(a) TSnDTC0 and TSnDTC1 Rewriting**

It is possible to rewrite the dead time setting in TSnDTC0 and TSnDTC1 registers during timer operation.

- Caution 1. Rewrite TSnDTC0 and TSnDTC1 when the reload function is used (TSnRMC = 0).
- Caution 2. The write protection code check function is applied when TSnDTC0 and TSnDTC1 are rewritten. Refer to the pertinent register description for details.
- Caution 3. When the TSnCMP0 and TSnDTC1 are updated at the peak of the 16-bit counter:
When a match occurs between the TSnCMPm set value and the updated TSnCMP0-TSnDTC1 (new maximum value with the main counter), the match interrupt (INTTSG2nIm) will not be generated immediately after reload (m = 02, 06, 10).



- Caution 4. When the TSnDTC0 is updated at the valley of the 16-bit counter:
When a match occurs between the TSnCMPm set value and the updated TSnDTC0 (new minimum value with the main counter), the match interrupt (INTTSG2nIm) is not generated immediately after reload (m = 01, 05, 09).

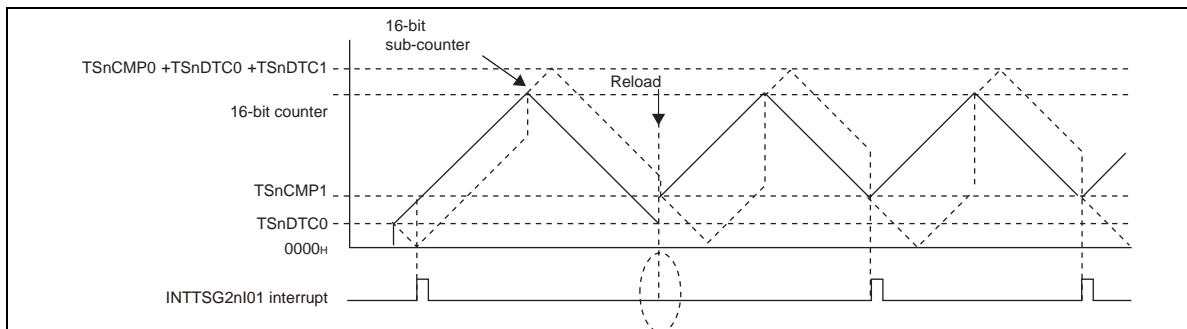

(9) Software Output Control Function in HT-PWM Mode

TSnOPT0.TSnSOC, TSnIDC, and TSnOPT1.TSnSPC2-TSnSPC0 are used in HT-PWM mode for software control of timer output control.

As shown in Figure 15-54, with TSnSTE = 0, the output control is switched immediately when TSnSOC is set to 1. If the dead time is set, the period of the dead time is guaranteed. After that, when TSnSOC is set to 0, output control is retained. When the reload timing is generated, output control is switched to HT-PWM mode output control.

For details, refer to Section 15.11.5, Software Output Control Function.

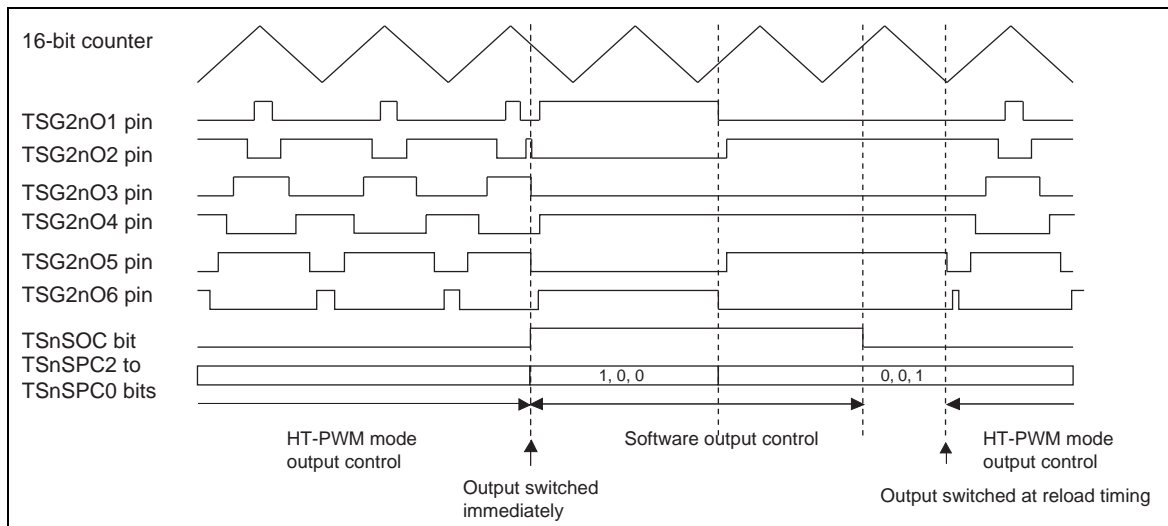

Figure 15-54 Example of Software Output Control Switching in HT-PWM Mode

Caution Use reload (simultaneous rewrite) mode (TSnCTL3.TSnRMC = 0) when software output control function is used.

(a) Procedure for Software Output Control

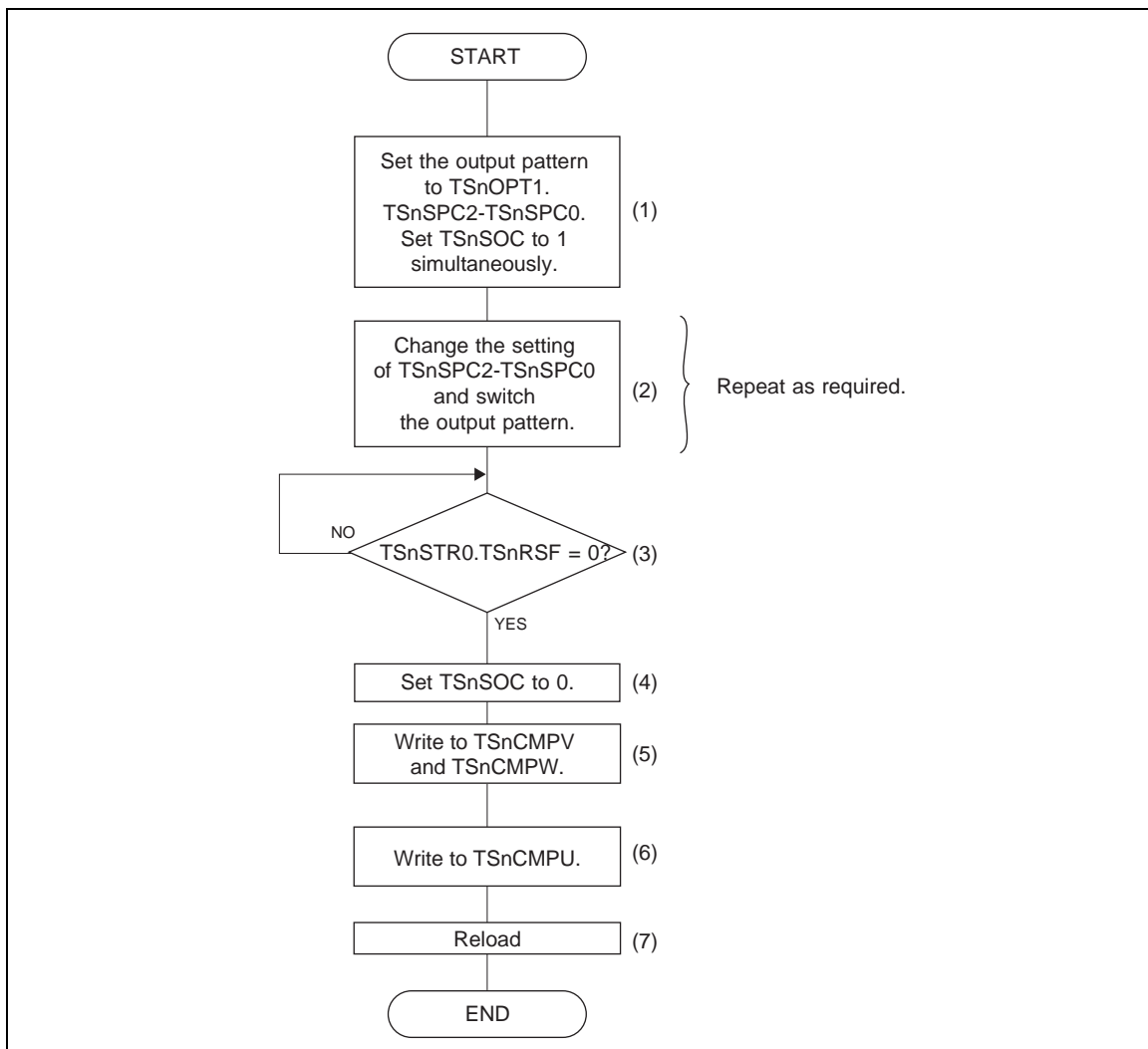

Figure 15-55 Flow of Software Output Control in HT-PWM Mode

The procedure for software output control is described below.

- (1) Set the output pattern to the TSnOPT1.TSnSPC2-TSnSPC0. To enable software output control, set TSnOPT0.TSnSOC to 1 simultaneously.
- (2) Change the output pattern setting of the TSnSPC2-TSnSPC0 to change the timer output. The registers that can be changed during software control are:
TSnTRG1.TSnTT, TSnCTL3-TSnCTL6, TSnOPT0, TSnOPT1,
TSnIOC1.TSnTOS, TSnCMPm (m = 0, 1, 2, 5, 6, 9, 10), TSnDTC0, and
TSnDTC1
- (3) Confirm that reload request flag TSnSTR0.TSnRSF = 0. In case TSnRSF = 1, do not proceed to the following step until TSnRSF = 0.
- (4) By setting TSnSOC = 0, the software control starts to be released (it is not released here yet).
- (5) After releasing the software output control, set the necessary compare registers. Proceed to the following step when the register setting is not required. Here, change the registers with the reload function.
- (6) Write to TSnCMPI (TSnCMP1) to start reloading.
- (7) Reload is executed and software output is released.

Caution Execute reload after executing steps (3), (4), (5), (6), and (7). When reload cannot be executed, the software output cannot be released.

(10) Asymmetric Triangular Wave Control in HT-PWM Mode

In HT-PWM mode, it is possible to control output by an asymmetric triangular waveform by setting the different timings for setting and clearing the U, V, and W phases.

The following describes the differences of the asymmetric triangular wave control from the symmetric triangular wave control.

(a) PWM Setting

When a symmetric triangular wave is used, the output control of each of the U phase, V phase, and W phase is done by setting the set timing and the clear timing to the same value to the TSnCMPU, TSnCMPV, and TSnCMPW. When an asymmetric triangular wave is used, the output control of each phase is done by setting TSnCMPm as follows (m = 1, 2, 5, 6, 9, 10):

- Prerequisites**
- The clear timing of PWM of the voltage data signal of U, V and W phases is set with TSnCMP1, TSnCMP5, and TSnCMP9.
 - The set timing of PWM of the voltage data signal of U, V, and W phases is set with TSnCMP2, TSnCMP6, and TSnCMP10.
 - The set and the clear timings of each phase can also be set with TSnCMP1W (TSnCMP1 and TSnCMP2), TSnCMP5W (TSnCMP5 and TSnCMP6), and TSnCMP9W (TSnCMP9 and TSnCMP10)
 - TSnCMPm can only be set to an even value (m = 1, 2, 5, 6, 9, 10).

(b) Timer Output

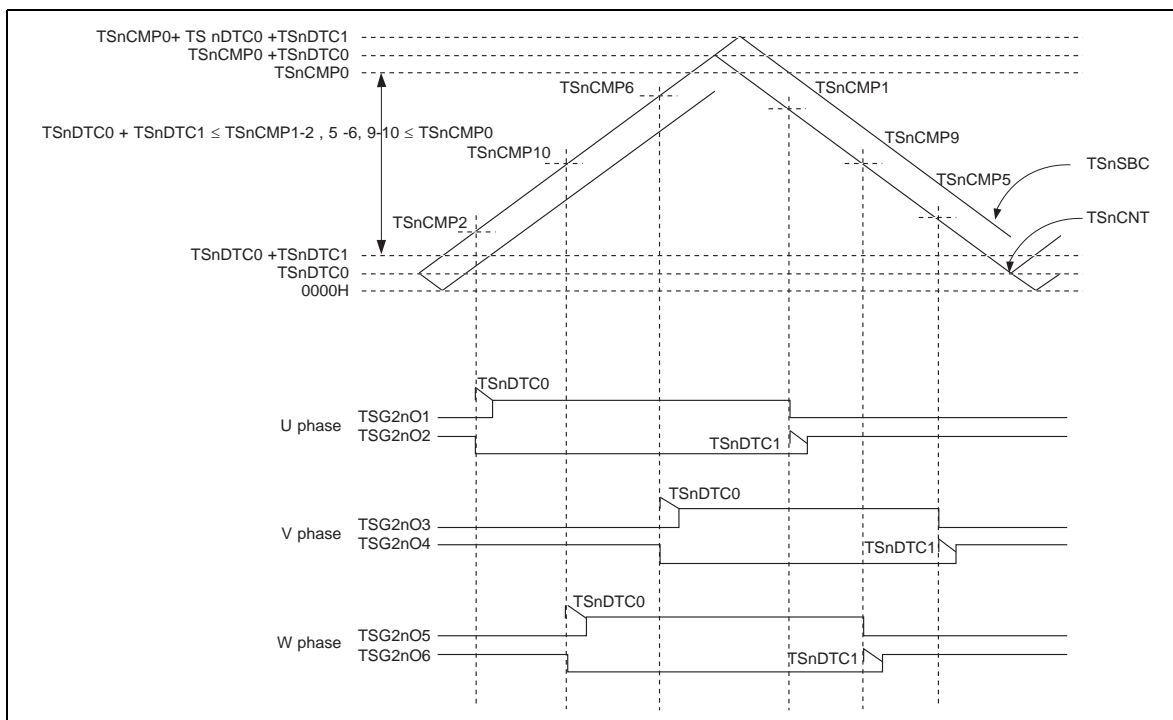

- Note When output is controlled by the asymmetric triangular waveform, the following conditions apply to setting of $TSnCMPm$ ($m = 1, 2, 5, 6, 9, 10$):
- $TSnDTC0 + TSnDTC1 \leq TSnCMPm \leq TSnCMP0$
 - Only when $TSnCMPm = TSnCMP(m+1)$ or $TSnCMPm = TSnCMP(m+1) + 2$, it is possible to set $TSnCMPm$ under the condition $0000_H \leq TSnCMPm \leq TSnCMP0 + TSnDTC0 + TSnDTC1$, which also applies to the case in which the symmetric triangular wave is used.

15.11.3 SP-PWM Mode (Shifted-pulse - Pulse Width Modulation Mode)

Overview In this mode, a 6-phase PWM can be generated using the 16-bit counter and the 16-bit compare registers.

- Prerequisites**
- The PWM signal cycle is set in TSnCMP0.
 - The set timings of the U phase, V phase, and W phase are set with TSnCMP2, TSnCMP6, and TSnCMP10, while the clear timings of these phases are set with TSnCMP1, TSnCMP5, and TSnCMP9 (when set timing and clear timing are used for control).
 - The set timings of the U phase, V phase, and W phase are set with TSnCMP2, TSnCMP6, and TSnCMP10 while the active periods of these phases are set with TSnUPW, TSnVPW, and TSnWPW. The sum of the set values of TSnCMP2, TSnCMP6, TSnCMP10, and the set values of TSnUPW, TSnVPW, TSnWPW are set to TSnCMP1, TSnCMP5, and TSnCMP9 respectively (when set timing and active period are used for control).

Functional description Set the carrier period and the set timings and duty of U phase, V phase, and W phase. The counting up begins when TSnTRG0.TSnTS is set to 1.

The 16-bit counter counts up from 0000_H and is cleared by match with TSnCMP0.

The dead time is set with TSnDTC0 and TSnDTC1. TSnDTC0 sets the dead time of inverse phase (OFF) to positive phase (ON) switch while TSnDTC1 sets that of positive phase (OFF) to inverse phase (ON) switch. The 10-bit counters (TSnDTT1 to TSnDTT3) for dead time generation load the set values of TSnDTC0 and TSnDTC1 at compare match of the 16-bit counter with the TSnCMP_m buffer register (m = 1, 2, 5, 6, 9, 10) and start down-counting.

INTTSG2nIm interrupts (m = 01, 02, 05, 06, 09, 10) are generated by the compare match of the 16-bit counter with the TSnCMP1, TSnCMP2, TSnCMP5, TSnCMP6, TSnCMP9, and TSnCMP10 buffer registers.

Note SP-PWM mode is enabled when TSnTRG0.TSnMD1 and TSnMD0 = 10_B.

(1) Basic Timing Chart

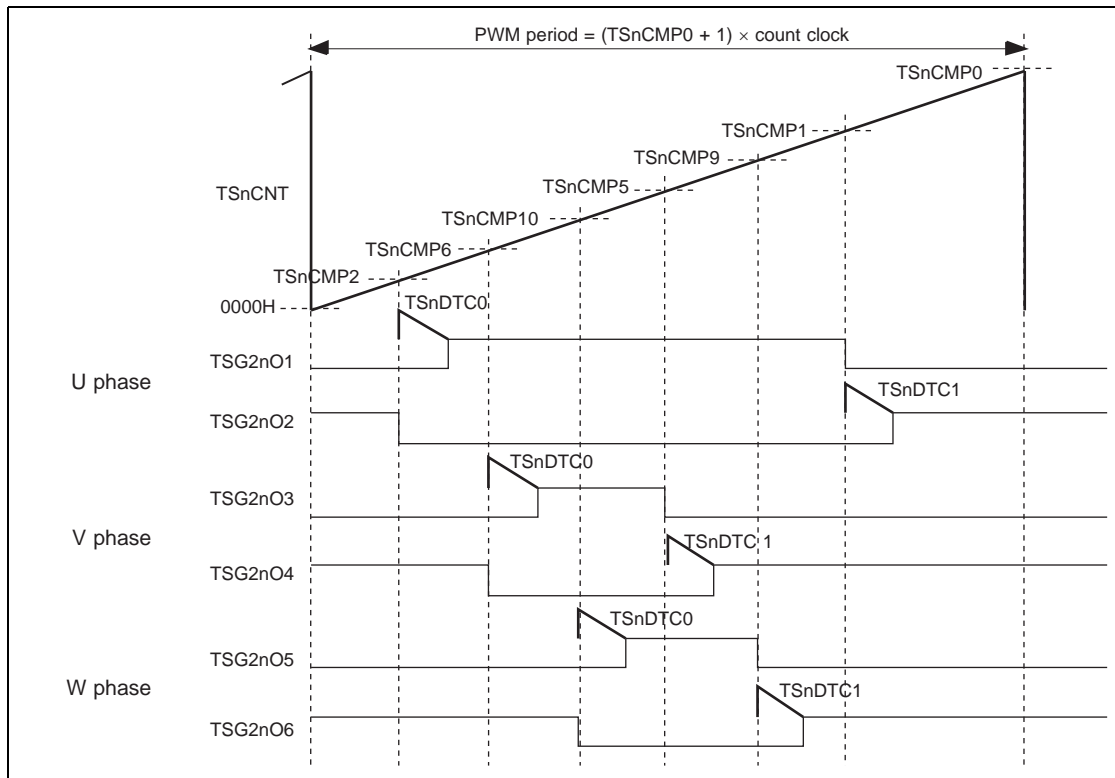

Figure 15-56 Basic Timing in SP-PWM Mode

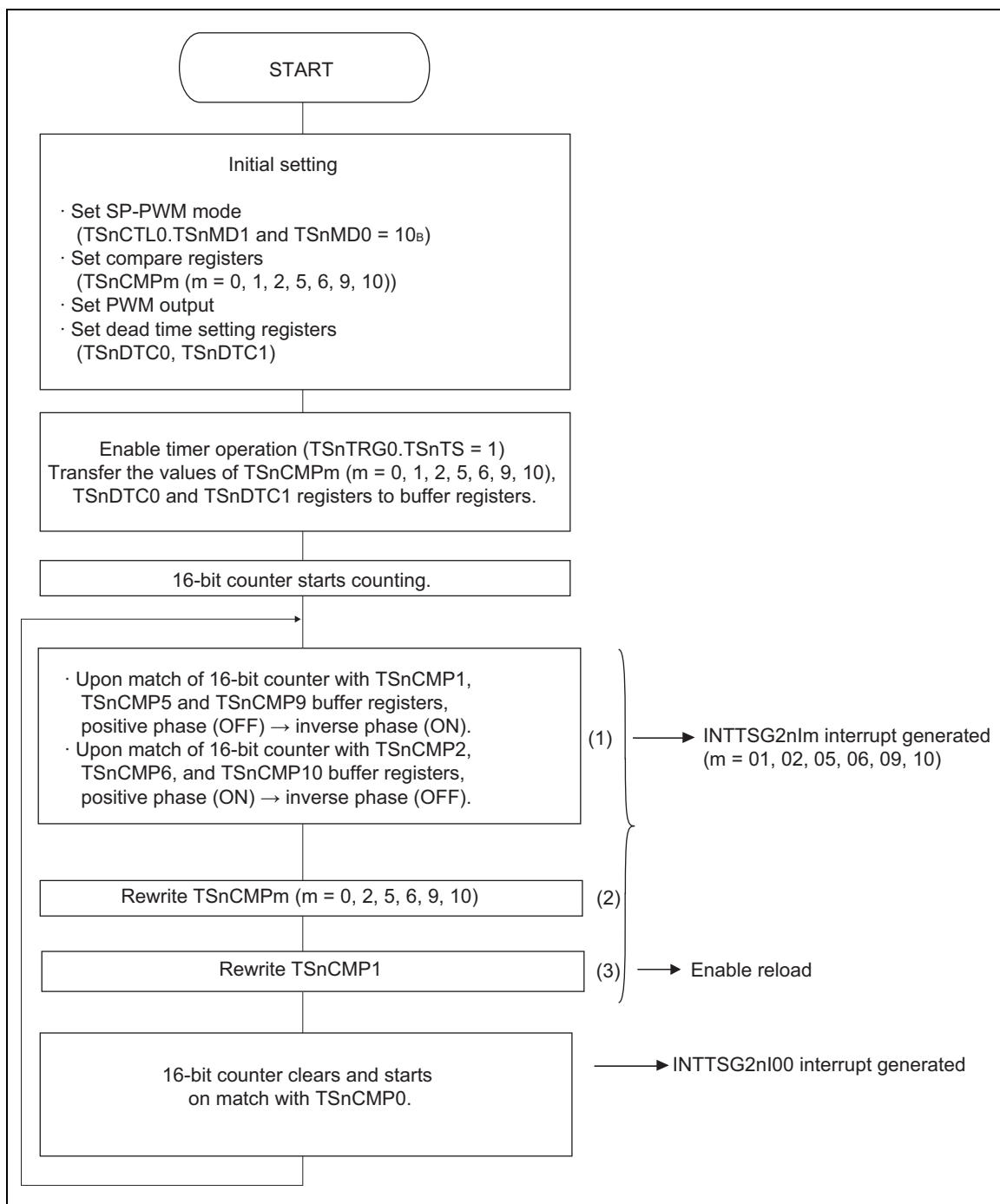

Figure 15-57 Basic Operation Flow in SP-PWM Mode

Note The timing of (1) may be different depending on the rewriting timing of (2) and (3).
Be sure to rewrite (2) followed by rewriting (3).

(2) List of SP-PWM Mode Operations

Table 15-61 Counter Functions in SP-PWM Mode

Operation		Setting Condition
16-bit counter	Start	TSnTRG0.TSnTS = 0 → 1
	Clear	Compare match of TSnCMP0 buffer register with 16-bit counter
	Stop	TSnTRG1.TSnTT = 0 → 1

Table 15-62 Compare Registers and Dead Time Setting Register Functions in SP-PWM Mode

Register	Rewriting Method	Rewrite during Operation	Function
TSnCMP0	Reload/Anytime rewrite	Possible	Setting period
TSnUPW	Reload/Anytime rewrite	Possible	PWM control for U phase
TSnCMP1W (TSnCMP1, TSnCMP2)	Reload/Anytime rewrite		
TSnVPW	Reload/Anytime rewrite	Possible	PWM control for V phase
TSnCMP5W (TSnCMP5, TSnCMP6)	Reload/Anytime rewrite		
TSnWPW, TSnCMP9W (TSnCMP9, TSnCMP10)	Reload/Anytime rewrite	Possible	PWM control for W phase
TSnDTC0, TSnDTC1	Reload		
TSnDCMP0W, TSnDCMP2	Reload/Anytime rewrite	Possible	Outputs a diagnostic signal or A/D conversion trigger.

Table 15-63 Output Functions in SP-PWM Mode

Pin	Function
TSG2nO1	PWM output with dead time by compare match of TSnCMP1 buffer register (clear timing) or TSnCMP2 buffer register (set timing) with 16-bit counter
TSG2nO2	Output inverse phase with respect to TSG2nO1 (with dead time)
TSG2nO3	PWM output with dead time by compare match of TSnCMP5 buffer register (clear timing) or TSnCMP6 buffer register (set timing) with 16-bit counter
TSG2nO4	Output inverse phase with respect to TSG2nO3 (with dead time)
TSG2nO5	PWM output with dead time by compare match of the TSnCMP9 buffer register (clear timing) or the TSnCMP10 buffer register (set timing) with the 16-bit counter
TSG2nO6	Output inverse phase with respect to TSG2nO5 (with dead time)
TSG2nO7	Diagnostic signal output or pulse output by A/D conversion trigger

Table 15-64 Interrupt Requests in SP-PWM Mode

Interrupt	Function
INTTSG2nIm (m = 00, 01, 02, 05, 06, 09, 10)	Compare match of TSnCMPm buffer register with 16-bit counter (m = 0, 1, 2, 5, 6, 9, 10)
INTTSG2nIER	Error

Table 15-64 Interrupt Requests in SP-PWM Mode

Interrupt	Function
INTTSG2nIVLY	-
INTTSG2nIPEK	Peak interrupt (generated at the same timing as INTTSG2nI00)
INTTSG2nIWN	Warning

Table 15-65 Compare Match Timing in SP-PWM Mode

Compare Match	Timing
TSnCMP0	When 16-bit counter changes from TSnCMP0 to 0000 _H
TSnCMPm (m = 1, 2, 5, 6, 9, 10)	After match of 16-bit counter and TSnCMPm is detected (m = 1, 2, 5, 6, 9, 10)

Table 15-66 Example of Setting Each Timer Output Condition in SP-PWM Mode (1/2)

Pin	Item	Output Period	Output Duty	
			Output Condition	Setting Condition
TSG2nO1, TSG2nO3, TSG2nO5	PWM output	$(TSnCMP0 + 1) \times \text{count clock}$	Output an inactive level throughout one period (duty 0%)	$TSnCMPm = TSnCMP(m + 1)$ or $TSnCMP(m + 1) > TSnCMP0$ (m = 1, 5, 9)
			Output an active level of one count clock in one period	$TSnCMPm = TSnCMP(m + 1) + 1$ $TSnCMP(m + 1) = TSnCMPm - 1$ (m = 1, 5, 9)
			Output an inactive level of one count clock in one period	$TSnCMPm = TSnCMP(m + 1) - 1$ $TSnCMP(m + 1) = TSnCMPm + 1$ (m = 1, 5, 9)
			Output an active level throughout one period (duty 100%)	$TSnCMPm > TSnCMP0$ $TSnCMP(m + 1) \leq TSnCMP0$ (m = 1, 5, 9)

Table 15-66 Example of Setting Each Timer Output Condition in SP-PWM Mode (2/2)

Pin	Item	Output Period	Output Duty	
			Output Condition	Setting Condition
TSG2nO2, TSG2nO4, TSG2nO6	PWM output	$(T_{SnCMP0} + 1) \times \text{count clock}$	Output an inactive level throughout one period (duty 0%)	$T_{SnCMPm} = T_{SnCMP(m-1)}$ or $T_{SnCMP(m-1)} > T_{SnCMP0}$ (m = 2, 6, 10)
			Output an active level of one count clock in one period	$T_{SnCMPm} = T_{SnCMP(m-1)} - 1$ $T_{SnCMP(m-1)} = T_{SnCMPm} + 1$ (m = 2, 6, 10)
			Output an inactive level of one count clock in one period	$T_{SnCMPm} = T_{SnCMP(m-1)} + 1$ $T_{SnCMP(m-1)} = T_{SnCMPm} - 1$ (m = 2, 6, 10)
			Output an active level throughout one period (duty 100%)	$T_{SnCMPm} > T_{SnCMP0}$ (m = 2, 6, 10)
TSG2nO7	Diagnostic signal output or pulse output by A/D conversion trigger	$(T_{SnCMP0} + 1) \times \text{count clock}$	Please refer to Section 15.9, A/D Conversion Trigger Function.	

(3) Various Settings of SP-PWM Mode

Mode Setting	SP-PWM mode is entered by setting TSnCTL0.TSnMD1-TSnMD0 to 10 _B .
Setting timer output	<p>The output pins TSG2nO1-TSG2nO6 are controlled by setting TSnIOC0, TSnIOC2, and TSnIOC3.</p> <p>The TSG2nO7 pin provides output pulse as diagnostic output or analog to digital conversion trigger. The pin should be set as necessary.</p>
Enabling error interrupt generation	Error interrupt (INTTSG2nIER) due to the detection of the simultaneous active state of the positive and inverse phases is enabled by setting TSnIOC1.TSnEOC to 1. For details, refer to Section 15.10, Error/Warning Interrupt.
Setting rewriting timing of register with reload function	<p>With the TSnCTL3.TSnRMC, reload (simultaneous rewrite) or rewrite (anytime) is specified for the registers with reload function. The default setting is 0 (reload). To reload, set TSnCTL4.TSnPRE to 1.</p> <p>No reload timing is generated when TSnPRE = 0.</p> <p>When "anytime rewrite" is specified, the unintended output may be generated depending on the rewrite timing.</p>
Setting analog to digital conversion trigger output	<p>The analog to digital conversion trigger 0 (TSnADTRG0 signal) is set with TSnCTL5.TSnAT09 to TSnAT00.</p> <p>TSnAT09 to TSnAT00 is used to enable or disable the A/D conversion trigger output on timing match of TSnDCMP2 to TSnDCMP0 with the 16-bit counter (up count).</p> <p>TSnCTL6.TSnAT19 to TSnAT10 is used to set the analog to digital conversion trigger 1 (TSnADTRG1 signal).</p> <p>To set the match timing of the 16-bit counter and TSnDCMP2 to TSnDCMP0, set the compare value to each register.</p> <p>The skipping function can be used for TSnADTRG0 and TSnADTRG1 signals. TSnACC00 and TSnACC01 of TSnCTL5, and TSnACC10 and TSnACC11 of TSnCTL6 can be used to select the skipping rate among 1/1, 1/2, 1/4, and 1/8.</p>

-
- | | |
|----------------|--|
| Caution | <ul style="list-style-type: none"> • Be sure to set TSnCTL5, TSnCTL6, and TSnDCMP2 to TSnDCMP0 correctly when the timing pulse of analog to digital conversion trigger is output to TSG2nO7. • In SP-PWM mode, no valley interrupt (INTTSG2nIVLY) is generated. Therefore, TSnCTL5.TSnAT00 and TSnCTL6.TSnAT10 must be set to 0. • In SP-PWM mode, the 16-bit sub-counter does not operate. Therefore, TSnAT09, and TSnAT08 in TSnCTL5, and TSnAT19, and TSnAT18 in TSnCTL6 must be set to 0. • In SP-PWM mode, down counting by the 16-bit counter is not generated. Therefore, TSnAT07, TSnAT05, and TSnAT03 in TSnCTL5 and TSnAT17, TSnAT15, and TSnAT13 in TSnCTL6 should be set to 0. |
|----------------|--|
-

Setting dead time The dead time can be set with TSnDTC0 and TSnDTC1.
The dead time is calculated by the following expressions:

$$\text{PCLK} \times \text{TSnDTC0}$$

$$\text{PCLK} \times \text{TSnDTC1}$$

TSnDTC0 can set the time between a change of TSG2nO2, TSG2nO4, and TSG2nO6 to the inactive state and a change of TSG2nO1, TSG2nO3, and TSG2nO5 to the active state, respectively.

TSnDTC1 can set the time between a change of TSG2nO1, TSG2nO3, and TSG2nO5 to the inactive state, and a change of TSG2nO2, TSG2nO4, and TSG2nO6 to the active state, respectively.

Carrier period Set the carrier period with TSnCMP0 according to the following expression:

$$\text{TSnCMP0} = (\text{carrier period/count clock cycle}) - 1$$

Caution PWM output with 100% duty cannot be produced when $\text{TSnCMP0} = \text{FFFF}_{\text{H}}$.

Setting duty (PWM width) The duty of U phase, V phase, and W phase is set with TSnCMPm, TSnUPW, TSnVPW, and TSnWPW (m = 1, 2, 5, 6, 9, 10), respectively.

- The set timings of the U phase, V phase, and W phase are set with TSnCMP2, TSnCMP6, and TSnCMP10, and the clear timings are set with TSnCMP1, TSnCMP5, and TSnCMP9. (The set and clear timing setting is used for control.)
- The set timings of U phase, V phase, and W phase is set with TSnCMP2, TSnCMP6, and TSnCMP10 while the active periods of these phases are set with TSnUPW, TSnVPW, and TSnWPW.
The sum of the set values of TSnCMP2, TSnCMP6, and TSnCMP10, and the set values of TSnUPW, TSnVPW, and TSnWPW are set to TSnCMP1, TSnCMP5, and TSnCMP9 respectively (when set timing and active period are used for control).

(4) Dead Time Control in SP-PWM mode

Duty setting registers are TSnCMPm (m = 1, 2, 5, 6, 9, 10), TSnUPW, TSnVPW, and TSnWPW and register for setting the period is TSnCMP0. The 6-phase PWM waveform of a variable duty is output by using these registers. To achieve the dead time control, there are six 10-bit down counters that operate synchronously with the count clock of the 16-bit counter and two dead time setting registers (TSnDTC0 and TSnDTC1). TSnDTC0 is used for setting a dead time from a change of the inverse phase to the inactive state to a change of the positive phase to the active state. TSnDTC1 is used for setting a dead time from a change of the positive phase to the inactive state to a change of the inverse phase to the active state. Figure 15-67 shows an example of the output waveform.

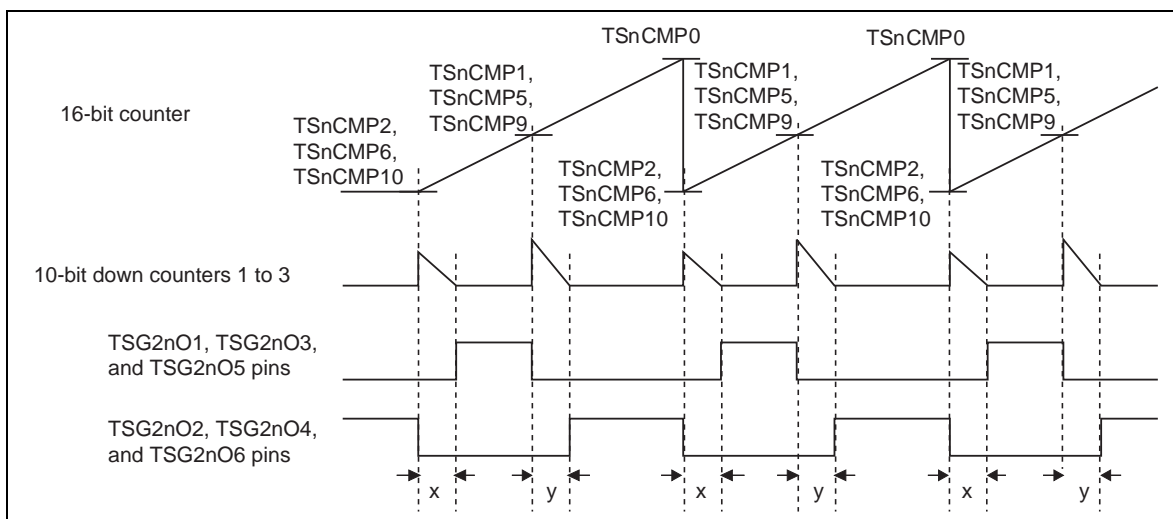

Figure 15-58 Example of Output Waveform in SP-PWM Mode

Note x: TSnDTC0 register values
y: TSnDTC1 register values

(5) Software Output Control Function in SP-PWM Mode

TSnOPT0.TSnSOC, TSnIDC, and TSnOPT1.TSnSPC2 to TSnSPC0 are used to control timer output by software.

As shown in Figure 15-59, the output control is switched immediately when TSnSOC is set to 1. If the dead time is set, the period of the dead time is guaranteed. After that, when TSnSOC is set to 0, output control is retained. When the reload timing is generated, output control is switched to SP-PWM mode output control.

For details, refer to Section 15.11.5, Software Output Control Function.

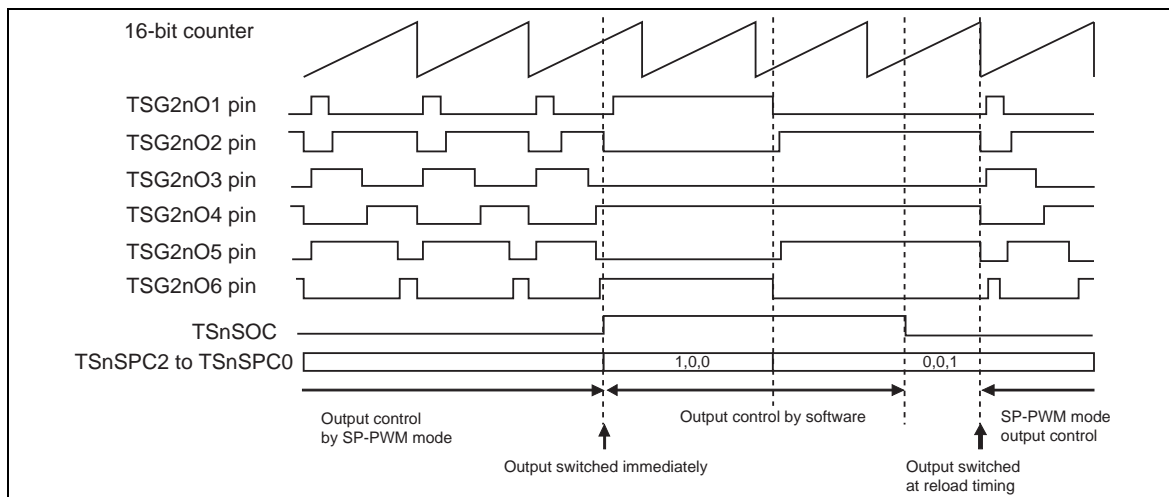

Figure 15-59 Example of Output Control Switching from SP-PWM Mode Control to Software Control

(a) Procedure on Software Output Control Processing

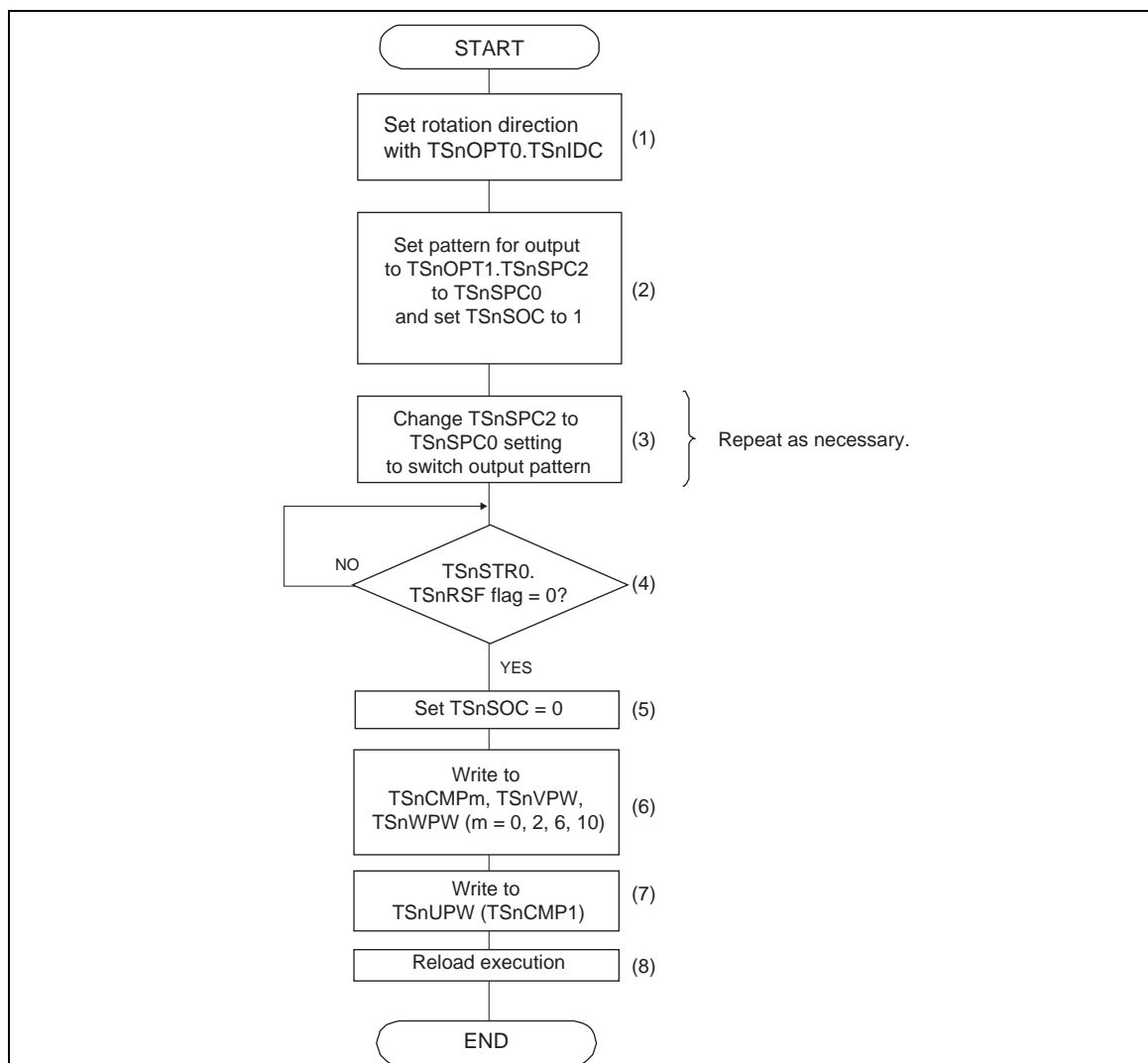

Figure 15-60 Flow of Software Output Control

The procedure for software output control is described below.

- (1) Set TSnOPT0 to determine the rotation direction. The timer output has a 180-degree phase shift between when TSnIDC = 0 and when TSnIDC = 1. With the software output control function, the timer output will not change only by rewriting the TSnOPT0 bit.
- (2) Set the pattern for output to TSnOPT1. At the same time, set TSnOPT0.TSnSOC to 1 to switch to software output control mode.
- (3) Change the output pattern setting for TSnSPC2-TSnSPC0 to change the timer output. During software control mode, the following registers can be modified:
TSnTRG0.TSnTS, TSnCTL3-TSnCTL6, TSnOPT0, TSnOPT1, TSnCMP0-TSnCMP12, TSnDTC0, and TSnDTC1.
- (4) Ensure that the reload request flag TSnSTR0.TSnRSF is 0. If TSnRSF is 1, do not shift to the following procedure until it goes 0.
- (5) By clearing TSnSOC to 0, software control starts to be released (not yet released here).

- (6) After software output control is released, set the compare registers if necessary. Move to the following procedure if no setting is required. In addition, change the registers with the reload function if necessary.
- (7) Write TSnUPW (TSnCMP1) to start reloading.
- (8) Reload is executed and software output control is released.

Caution Be sure to execute reload after execution of steps (4), (5), (6), and (7). Unless reload can be executed, software output control cannot be released

15.11.4 120-DC Mode

Overview In this mode, PWM output period set to TSnCMP0 and timer output (TSG2nO1 to TSG2nO6) according to the duty cycle set to TSnCMP1 to TSnCMP12 are controlled with three types of pattern inputs (software output control method, pattern switch method, and trigger switch method) to perform 120-DC control.

- Prerequisites**
- Set the PWM period to TSnCMP0.
 - Set the PWM duty to TSnCMP1 to TSnCMP12 and set the output pattern to TSnPAT0W and TSnPAT1W.

Functional description Set the PWM period, set the duty cycle to individual compare register, and set the pattern to be output to the pattern register. Setting TSnTRG0.TSnTS to 1 starts counting.

The 16-bit counter starts counting from 0000_H, and is cleared by the match with TSnCMP0.

INTTSG2nI01 to INTTSG2nI12 interrupts are generated by a compare match of the 16-bit counter and TSnCMP1 to TSnCMP12 buffer registers, respectively.

Note 120-DC mode is valid when TSnCTL0.TSnMD1 to TSnMD0 are set to 11_B.

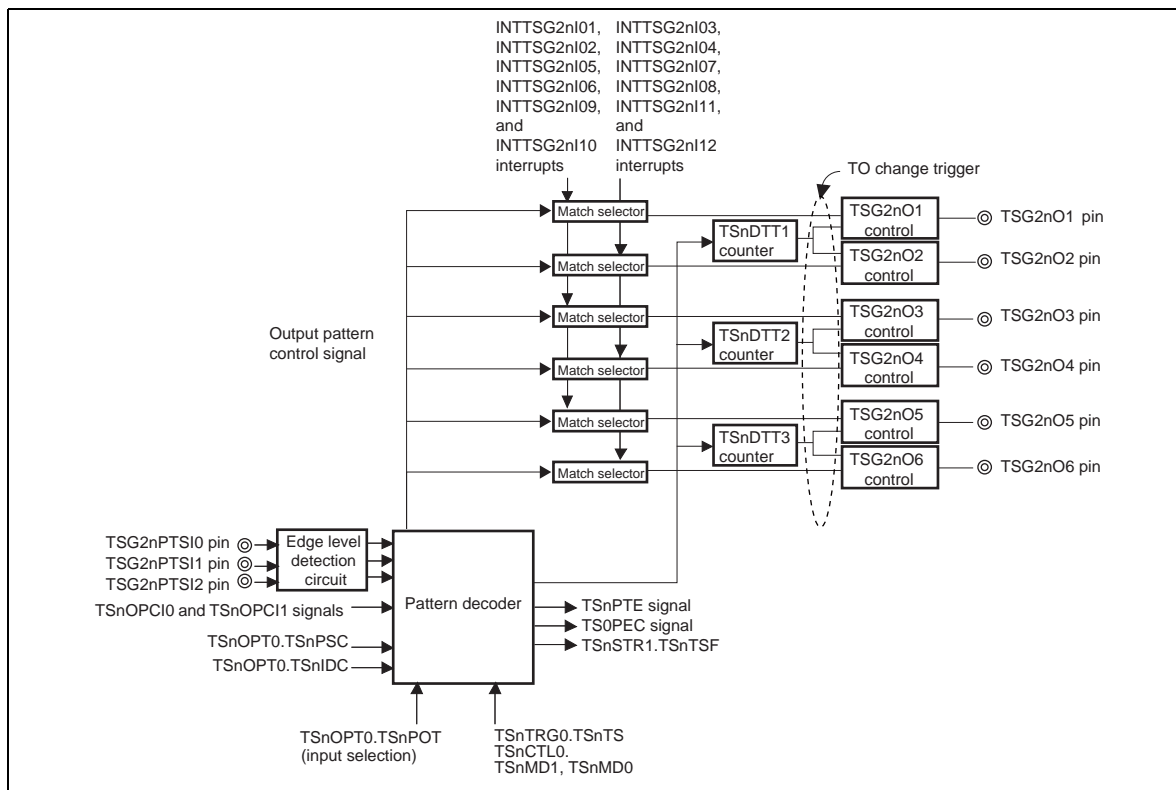

Figure 15-61 Block Diagram in 120-DC Mode

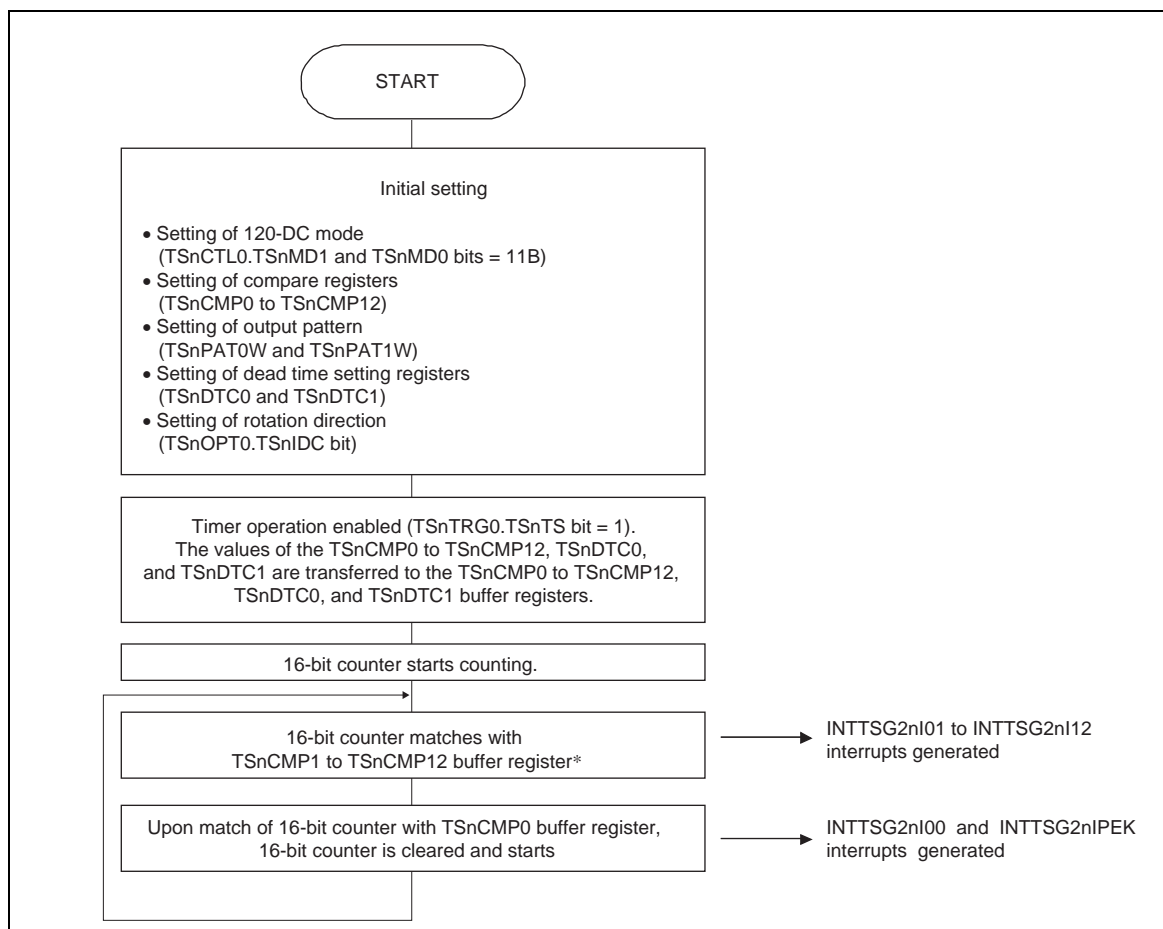

Figure 15-62 Basic Operation Flow in 120-DC Mode

Note * The 16-bit counter is not cleared by match of the 16-bit counter with the TSncMP1 to TSncMP12 buffer registers.

(1) List of Operations in 120-DC Mode

Table 15-67 Counter Functions in 120-DC Mode

Operation		Setting Condition
16-bit counter	Start	TSnTRG0.TSnTS = 0 → 1
	Clear	Match of TSnCMP0 value and 16-bit counter value, or output pattern switch timing
	Stop	TSnTRG1.TSnTT = 0 → 1

Table 15-68 Functions of Compare Registers and Dead Time Setting Registers in 120-DC Mode

Register	Rewrite Method	Rewrite during Operation	Function
TSnCMP0	Reload	Possible	Setting period
TSnCMPm (m = 1 to 12)	Reload	Possible	Setting PWM duty
TSnDCMP0W, TSnDCMP2	Reload/Anytime rewrite	Possible	Outputs a diagnostic signal or A/D conversion trigger
TSnDTC0, TSnDTC1	Reload	Possible	Setting dead time

Table 15-69 Timer Input Function in 120-DC Mode

Pin/Signal	Function
TSG2nPTSI2 to TSG2nPTSI0 pins	Pattern input (3 phases)
TSnOPCI0, TSnOPCI1 signals	Trigger input

Table 15-70 Timer Output Function in 120-DC Mode

Pin/Signal	Function
TSG2nO1 pin	PWM output (with dead time) by compare match of the TSnCMPm buffer register (m = 1, 2, 5, 6, 9, 10) with the 16-bit counter and by selecting output pattern through TSnPAT0W setting.
TSG2nO2 pin	PWM output (with dead time) by compare match of the TSnCMPm buffer register (m = 3, 4, 7, 8, 11, 12) and the 16-bit counter and by selecting output pattern through TSnPAT1W setting.
TSG2nO3 pin	PWM output (with dead time) by compare match of the TSnCMPm buffer register (m = 1, 2, 5, 6, 9, 10) and the 16-bit counter and by selecting output pattern through TSnPAT0W setting.
TSG2nO4 pin	PWM output (with dead time) by compare match of the TSnCMPm buffer register (m = 3, 4, 7, 8, 11, 12) and the 16-bit counter and by selecting output pattern through TSnPAT1W setting.
TSG2nO5 pin	PWM output (with dead time) by compare match of the TSnCMPm buffer register (m = 1, 2, 5, 6, 9, 10) and the 16-bit counter and by selecting output pattern through TSnPAT0W setting.
TSG2nO6 pin	PWM output (with dead time) by a compare match of the TSnCMPm buffer register (m = 3, 4, 7, 8, 11, 12) and the 16-bit counter and by selecting output pattern through TSnPAT1W setting.
TSG2nO7 pin	Diagnostic signal output or pulse output by A/D conversion trigger
TSnPTE signal	Toggle signal by change in input pattern

Table 15-71 Interrupt Requests in 120-DC Mode

Interrupt	Function
INTTSG2nIm (m = 00 to 12)	Compare match of TSnCMPm buffer register and 16-bit counter (m = 0 to 12)
INTTSG2nIER	Error
INTTSG2nIVLY	-
INTTSG2nIPEK	Peak interrupt (generated at the same timing as INTTSG2nI00)
INTTSG2nIWN	Warning interrupt

Table 15-72 Compare Match Timing in 120-DC Mode

Compare Match	Timing
TSnCMP0	When 16-bit counter changes from TSnCMP0 to 0000 _H
TSnCMPm (m = 1 to 12)	After detecting the match of 16-bit counter and TSnCMPm (m = 1 to 12)

Table 15-73 Example of Setting Each Timer Output Condition in 120-DC Mode

Pin	Item	Output Period	Output Duty	
			Output Condition	Setting Condition
TSG2nOm (m = 1 to 6)	PWM output	$(TSnCMP0 + 1) \times \text{count clock}$	See Section 15.11.4 (6), List of Output Patterns in 120-DC Mode.	-
TSG2nO7	Diagnostic signal output or pulse output by A/D conversion trigger	$(TSnCMP0 + 1) \times \text{count clock}$	See Section 15.9, A/D Conversion Trigger Function.	-

(2) Various Settings of 120-DC Mode

Mode setting	120-DC mode can be used by setting TSnCTL0.TSnMD1 and TSnMD0 are set to 11 _B .
Setting timer output	The output pins TSG2nO1 to TSG2nO6 are controlled by setting TSnIOC0, TSnIOC2, and TSnIOC3. The TSG2nO7 pin outputs pulses of the diagnostic output or the A/D conversion trigger. Please set it as required.
Enabling error interrupt generation	With TSnIOC1.TSnEOC = 1, the error interrupt (INTTSG2nIER) generation is enabled when the simultaneous active state of the positive phase and inverse phase is detected. For details, see Section 15.10, Error/Warning Interrupt.
Setting register rewrite timing	Reloading the registers with the reload function is activated with TSnCTL3.TSnRMC (simultaneous rewrite; default setting is 0 = reload). Set TSnCTL4.TSnPRE to 1 when reload is used. The reload timing is not generated if TSnPRE is 0.
Setting A/D conversion trigger output	To set A/D conversion trigger 0 (TSnADTRG0 signal), use TSnCTL5.TSnAT09 to TSnAT00. With TSnAT09 to TSnAT00, A/D conversion trigger output is enabled or disabled at the match of the 16-bit counter and TSnDCMP2 to TSnDCMP0 (during up count). To set A/D conversion trigger 1 (TSnADTRG1 signal), use TSnCTL6.TSnAT19 to TSnAT10. To set the match timing of the 16-bit counter and TSnDCMP2 to TSnDCMP0, set the compare value to the pertinent register. The skipping function can be used for TSnADTRG0 and TSnADTRG1 signals. Use TSnACC01, TSnACC00 of TSnCTL5 and TSnACC11, and TSnACC10 in TSnCTL6 to select the skipping rate among 1/1, 1/2, 1/4, and 1/8.

-
- Caution
- Set TSnCTL5, TSnCTL6, and TSnDCMP2 to TSnDCMP0 correctly when using the TSG2nO7 output for the A/D conversion trigger timing pulse.
 - In 120-DC mode, a valley interrupt (INTTSG2nIVLY) is not generated. Therefore, set TSnAT00 and TSnAT10 in TSnCTL5 and TSnCTL6 to 0.
 - In 120-DC mode, the 16-bit sub-counter does not operate. Therefore, set TSnAT09, TSnAT08, TSnAT19, and TSnAT18 in TSnCTL5 and TSnCTL6 to 0.
 - In 120-DC mode, the 16-bit counter does not decrement. Therefore, set TSnAT07, TSnAT05, TSnAT03, TSnAT17, TSnAT15, and TSnAT13 in TSnCTL5 and TSnCTL6 to 0.
-

Setting dead time The dead time can be set with TSnDTC0 and TSnDTC1.
The dead time is calculated by the following expressions:

$$PCLK \times TSnDTC0$$

$$PCLK \times TSnDTC1$$

TSnDTC0 can set the time between a change of TSG2nO2, TSG2nO4, and TSG2nO6 to the inactive state and a change of TSG2nO1, TSG2nO3, and TSG2nO5 to the active state, respectively.

TSnDTC0 can set the time between a change of TSG2nO1, TSG2nO3, and TSG2nO5 to the inactive state to a change of TSG2nO2, TSG2nO4, and TSG2nO6 to the active state.

Carrier period Set the carrier period with TSnCMP0 according to the following expression:

$$TSnCMP0 = (\text{carrier period/count clock cycle}) - 1$$

Duty (PWM width) setting The duty of PWM output is set with TSnCMP1 to TSnCMP12. The setting range of the compare registers is as follows:

$$0000_H \leq TSnCMPm \leq TSnCMP0 + 1$$

Caution Do not set TSnCMPm to TSnCMP0 + 1 (m = 1 to 12) only when TSnCMP0 + 1 < TSnCMPm and TSnCMP0 = FFFF_H.

Output PWM setting In 120-DC mode, the output pins TSG2nO1, TSG2nO3, and TSG2nO5 are controlled by TSnCMP1, TSnCMP2, TSnCMP5, TSnCMP6, TSnCMP9, and TSnCMP10, and the output pins TSG2nO2, TSG2nO4, TSG2nO6 are controlled by TSnCMP3, TSnCMP4, TSnCMP7, TSnCMP8, TSnCMP11, and TSnCMP12. The duty cycle of a PWM period (TSnCMP0) can be set with TSnCMP1 to TSnCMP12. Setting TSnCMP1 to TSnCMP12 to 0000_H sets the PWM duty cycle to 0%. Setting TSnCMP1 to TSnCMP12 to TSnCMP0 + 1 value sets the PWM duty cycle to 100%. This allows chopping output control and rectangular wave output control.

(3) Control Methods in 120-DC Mode

Control methods in 120-DC mode are listed below.

Control Method	Function
Software output control method	Switches the output pattern according to the TSnOPT1.TSnSPC2 to TSnSPC0 setting made by software.
Pattern switch method	Directly switches the output pattern by the pattern input signal of TSG2nPTSI0 to TSG2nPTSI2.
Trigger switch method	Switches the output pattern by the trigger switch method using the trigger input signals TSnOPCI0 and TSnOPCI1 or by the pattern input setting of TSnOPT1.TSnSPC2 to TSnSPC0 in the constant order.

Setting software output control method Setting TSnOPT0.TSnSTE = 0 switches the output pattern by software output control. The TSG2nO1 to TSG2nO6 pin output is switched according to TSnOPT1.TSnSPC2 to TSnSPC0.

The output order at the beginning of operation is set with TSnOPT0.TSnIDC. The output pattern is set with TSnOPT0.TSnPSC.

Operation of software output control method The PWM output of TSG2nO1 to TSG2nO6 pins (PWM output defined by TSnCMP1 to TSnCMP12) is selected by TSnOPT1.TSnSPC2 to TSnSPC0 by software. To control the dead time, the dead time counter is activated at the falling edge of the signals in each phase and the dead time is inserted.

The 16-bit counter counts based on the carrier period set in TSnCMP0. The 16-bit counter is cleared by match of the 16-bit counter and TSnCMP0 or by a write access to TSnOPT1.TSnSPC2 to TSnSPC0.

In this method, the pattern is output, which is decoded using information on the output pattern (TSnSPC2 to TSnSPC0), the electric current direction control bit (TSnOPT0.TSnIDC), and TSG2nPTSI2 to TSG2nPTSI0 pattern order detection flag (TSnSTR1.TSnTSF). Figure 15-83 shows the timer output when the output pattern is changed by software output control.

Immediately after the operation starts (TSnTRG0.TSnTS = 1), the output pattern of TSnSPC2 to TSnSPC0 and the pattern set with TSnIDC and TSnPSC (TSnOPT0.TSnPSS = 1) are output.

Setting pattern switch method Setting TSnOPT0.TSnSTE to 1 and TSnPOT to 0 selects the pattern switch method. The TSG2nO1 to TSG2nO6 pin output is changed at the change timing of the TSG2nPTSI2 to TSG2nPTSI0 pins.

The output order at the beginning of operation is set with TSnOPT0.TSnIDC. The initial output pattern is set with TSnOPT0.TSnPSC. However, after determining the rotation direction (after the value is set to TSnSTR1.TSnTSF), the setting of TSnPSC is disabled.

Operation of pattern switch method After level detection is performed for the pins (three inputs from the hall sensor), the level-detected signals are decoded. From the decoding result, the PWM output of TSG2nO1 to TSG2nO6 pins (PWM output defined by TSnCMP1 to TSnCMP12) is selected. To control the dead time, the dead time counter is activated at the falling timing of signals in each phase and the dead time is inserted.

The 16-bit counter counts based on the carrier period set in TSnCMP0. The 16-bit counter is cleared by match of the 16-bit counter and TSnCMP0 or by a change of the input pattern (TSG2nPTSI2 to TSG2nPTSI0 pins).

In this method, the pattern, which is decoded by using information on input pattern (TSG2nPTSI2 to TSG2nPTSI0), the electric current direction control bit (TSnOPT0.TSnIDC), and TSG2nPTSI2 to TSG2nPTSI0 pattern order detection flag (TSnSTR1.TSnTSF), is output. Figure 15-65 to Figure 15-68 show the timer output when TSG2nPTSI2 to TSG2nPTSI0 pin inputs change. If input pattern 1 is switched to input pattern 4 due to an abnormal input pattern, the output pattern is switched to the pattern corresponding to the input pattern.

Immediately after the operation starts (TSnTRG0.TSnTS = 1), the output pattern set with the input level of TSG2nPTSI2 to TSG2nPTSI0 pins, TSnIDC, and TSnPSC (TSnOPT0.TSnPSS = 1) is output. After the TSnTSF value is determined, the output pattern is determined by TSnTSF instead of TSnPSC.

Caution When connecting the three-phase pulse input signal to the TSG2nPTSI2 to TSG2nPTSI0 pins, confirm that the three-phase pulse input value and the patterns output from the TSG2nO1 to TSG2nO6 pins satisfy the expected conditions.

If the expected conditions are not satisfied, change the connection between the three-phase pulse input signal and the TSG2nPTSI2 to TSG2nPTSI0 pins.

Setting trigger switch method Setting TSnOPT0.TSnSTE and TSnPOT to 1 selects the trigger switch method. The output pins TSG2nO1 to TSG2nO6 are changed at a rising edge of an external input (TSnOPCI1 and TSnOPCI0 signals).

For pattern output order, see Section 15.11.4 (5), Operation in 120-DC Mode.

The initial output pattern can be controlled with TSnOPT1.TSnSPC2 to TSnSPC0.

When starting the TSG2n operation (TSnTRG0.TSnTS = 1) after setting TSnSPC2 to TSnSPC0, the initial pattern is output. For details, see Section 15.11.4 (6), List of Output Patterns in 120-DC Mode.

Operation of trigger switch method With the trigger input switch method, the rising edges of the TSnOPCI0 and TSnOPCI1 signals are detected and the output switch timing is generated. The initial timer output pattern is set with TSnOPT1.TSnSPC2 to TSnSPC0. The subsequent output patterns are determined with TSnSPC2 to TSnSPC0, TSnOPT0.TSnIDC, and TSnPSC.

The 16-bit counter counts based on the carrier period set in TSnCMP0. The 16-bit counter is cleared by match of the 16-bit counter and TSnCMP0, by a write access to TSnOPT1.TSnSPC2 to TSnSPC0, or by detecting a rising of TSnOPCI0 and TSnOPCI1 signals.

For examples of operation in 120-DC mode when trigger input switch method is used, see Figure 15-65 to Figure 15-68.

Caution The initial pattern should be set according to the read input level of the port to which TSG2nPTSI2 to TSG2nPTSI0 pins are connected.

(4) Timer Output in 120-DC Mode

In 120-DC mode, the PWM output is controlled with TSnPAT0W, TSnPAT1W, and TSnCMP1 to TSnCMP12. TSnPAT0W, TSnCMP1, TSnCMP2, TSnCMP5, TSnCMP6, TSnCMP9, and TSnCMP10 are set to control the output of TSG2nO1, TSG2nO3, and TSG2nO5 pins. TSnPAT1W, TSnCMP3, TSnCMP4, TSnCMP7, TSnCMP8, TSnCMP11, and TSnCMP12 are set with the output of TSG2nO2, TSG2nO4, and TSG2nO6 pins.

With PWM output control, eight types of output patterns can be selected for each of TSG2nO1, TSG2nO3, and TSG2nO5 pins and TSG2nO2, TSG2nO4, and TSG2nO6 pins.

Table 15-74 TSnPAT0W Set Value and Output Control

PATmT Value	Output Control
000	Fixed to low
001	PWM output set with TSnCMP1
010	PWM output set with TSnCMP2
011	PWM output set with TSnCMP5
100	PWM output set with TSnCMP6
101	PWM output set with TSnCMP9
110	PWM output set with TSnCMP10
111	Fixed to high

(m = 0, 1, 2, 3, 4, 5)

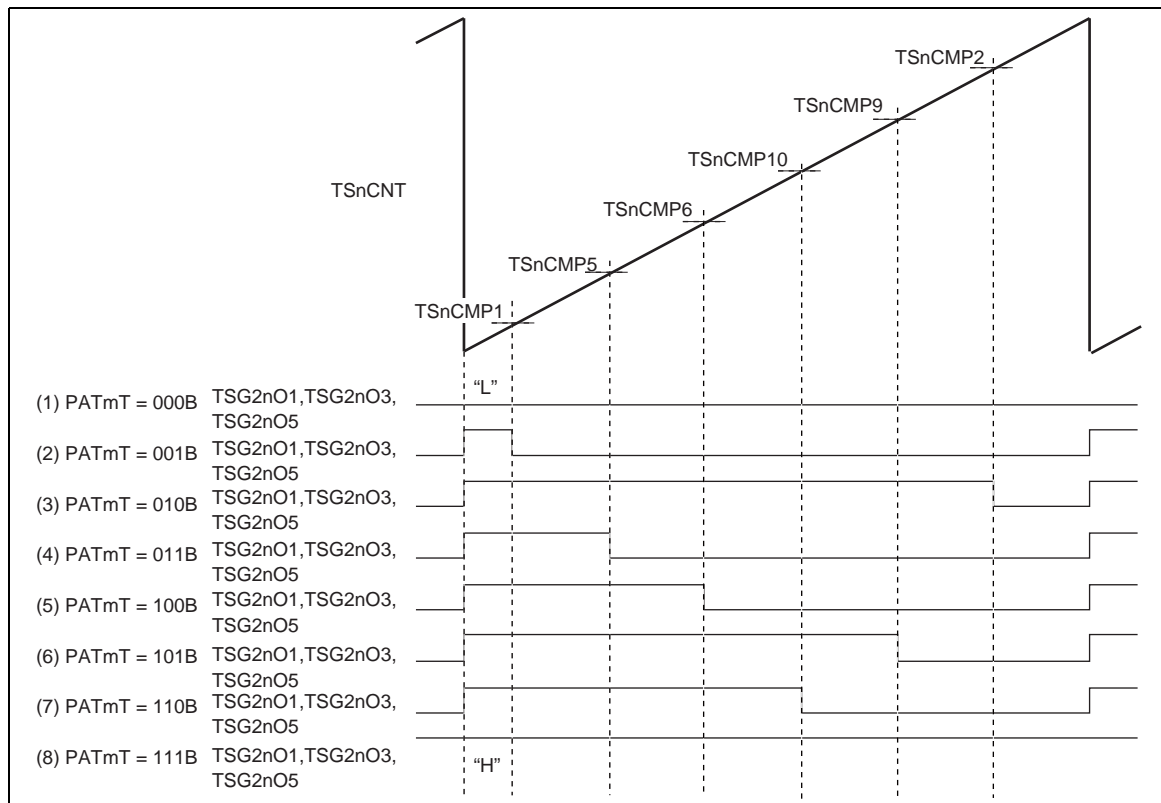

Figure 15-63 TSG2nO1, TSG2nO3, TSG2nO5 Pin Output of Each Output Pattern

Table 15-75 TSnPAT1W Set Value and Output Control

PATmB Value	Output Control
000	Fixed to low
001	PWM output set with TSnCMP3
010	PWM output set with TSnCMP4
011	PWM output set with TSnCMP7
100	PWM output set with TSnCMP8
101	PWM output set with TSnCMP11
110	PWM output set with TSnCMP12
111	Fixed to high

(m = 0, 1, 2, 3, 4, 5)

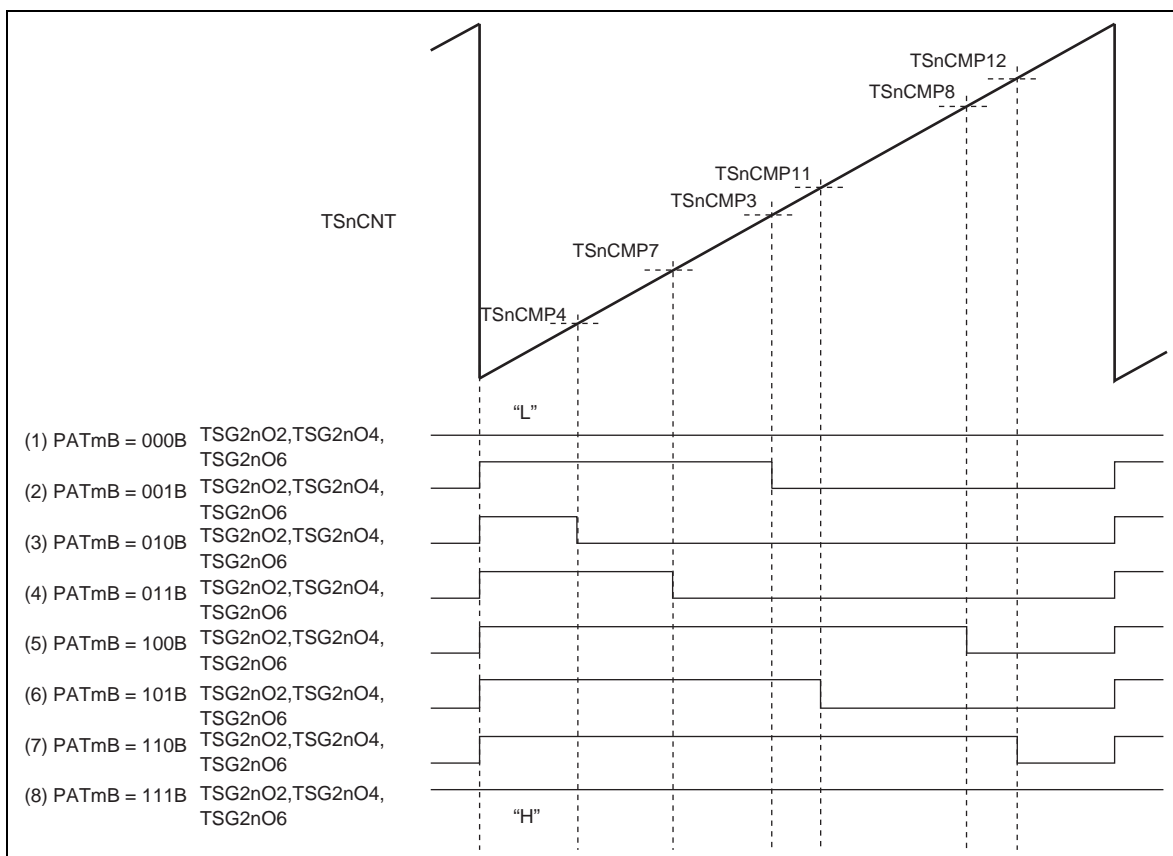

Figure 15-64 TSG2nO2, TSG2nO4, TSG2nO6 Pin Output of Each Output Pattern

(5) Operation in 120-DC Mode

Figure 15-65 to Figure 15-68 show examples of operation in 120-DC mode.

The TSG2nO1 to TSG2nO6 pins detect the input level change of the TSG2nPTS12 to TSG2nPTS10 pins, then change the output pattern. The 16-bit counter produces sawtooth waveform, and TSnCMP0 to TSnCMP12 output PWM signal. The 16-bit counter is cleared to 0000_H each time the counter value matches with TSnCMP0 or a change in the TSG2nPTS12 to TSG2nPTS10 pins is detected. The timer output pattern is switched each time a change in the TSG2nPTS12 to TSG2nPTS10 pins is detected.

Note PAT0T to PAT5T and PAT0B to PAT5B show PWM operation set by TSnCMP1 to TSnCMP12, respectively.

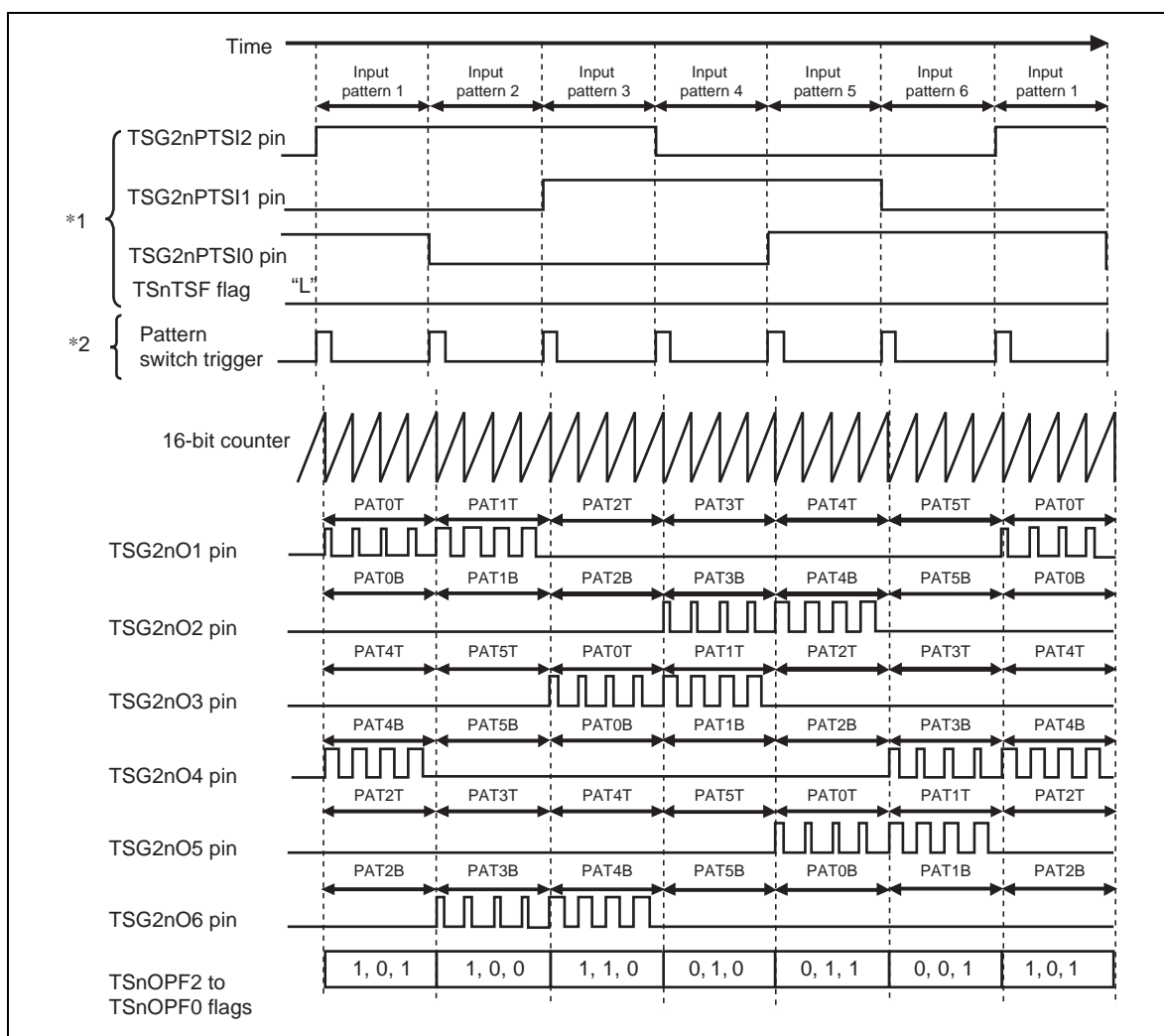

Figure 15-65 Example of Operation in 120-DC Mode (Normal Rotation: TSnSTR1.TSnTSMF = 0 and TSnOPT0.TSnIDC = 0)

- Note 1. For pattern switch method (TSnOPT0.TSnPOT = 0)
- Note 2. For trigger switch method (TSnOPT0.TSnPOT = 1 and TSnPSS = 1)

Note TSnOPT0.TSnSOC = 0

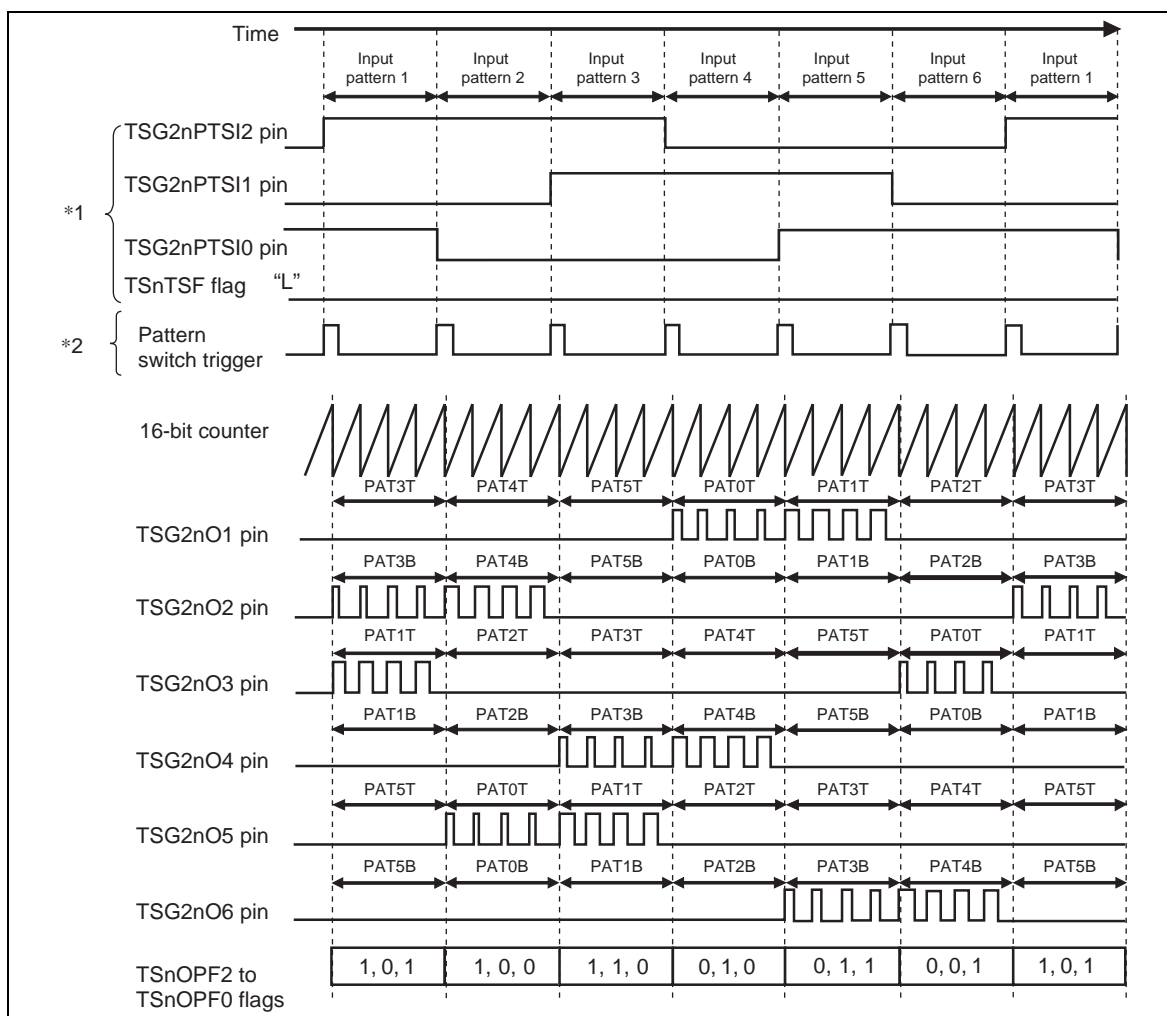

Figure 15-66 Example of Operation in 120-DC Mode (Normal Rotation: TSnSTR1.TSnTSF = 0 and TSnOPT0.TSnIDC = 1)

Note 1. For pattern switch method (TSnOPT0.TSnPOT = 0)

Note 2. For trigger switch method (TSnOPT0.TSnPOT = 1 and TSnPSS = 1)

Note TSnOPT0.TSnSOC = 0

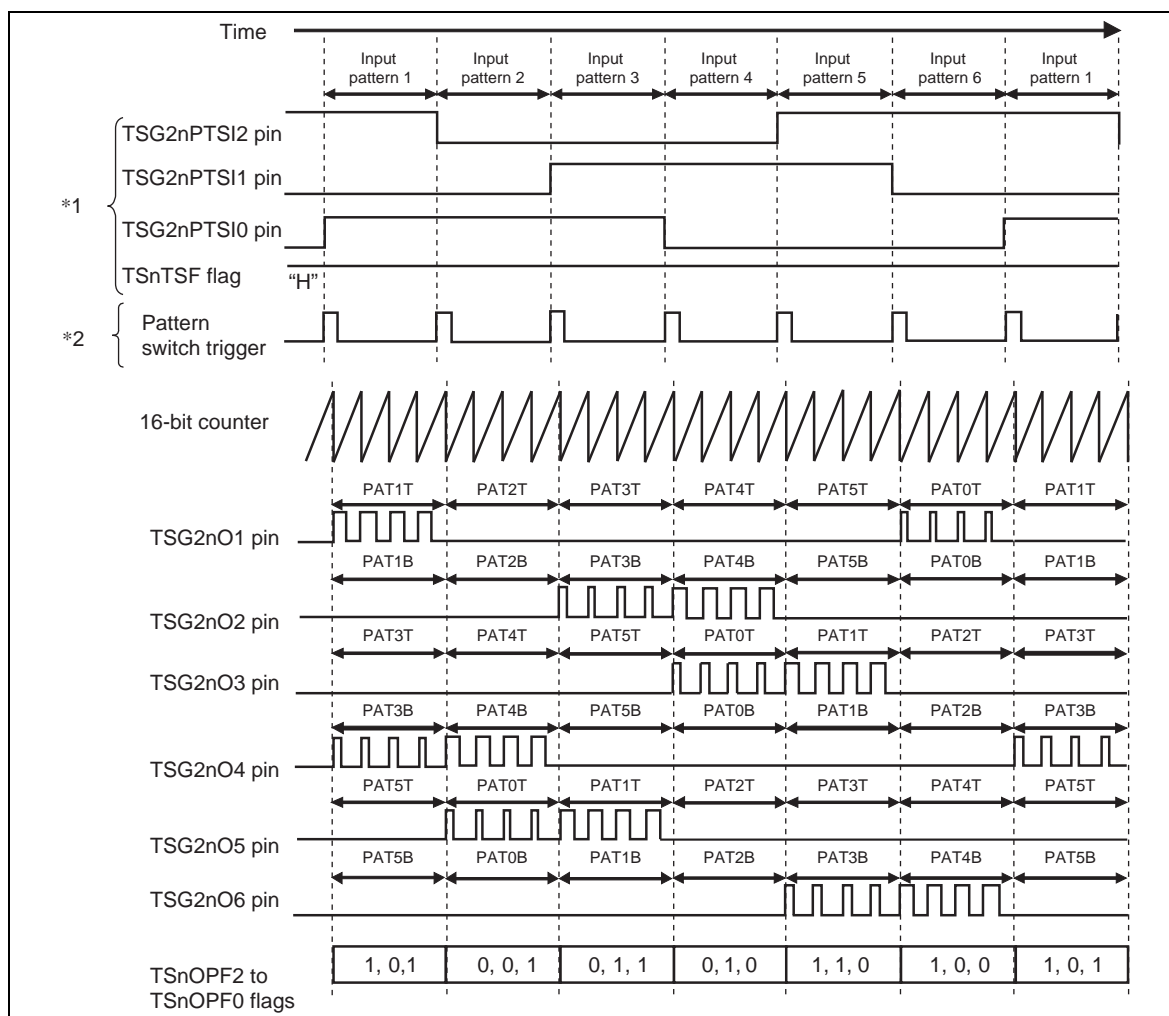

Figure 15-67 Example of Operation in 120-DC Mode (Reverse Rotation: TSnSTR1.TSnTTSF = 1 and TSnOPT0.TSnIDC = 0)

Note 1. For pattern switch method (TSnOPT0.TSnPOT = 0)

Note 2. For trigger switch method (TSnOPT0.TSnPOT = 1 and TSnPSS = 1)

Note TSnOPT0.TSnSOC = 0

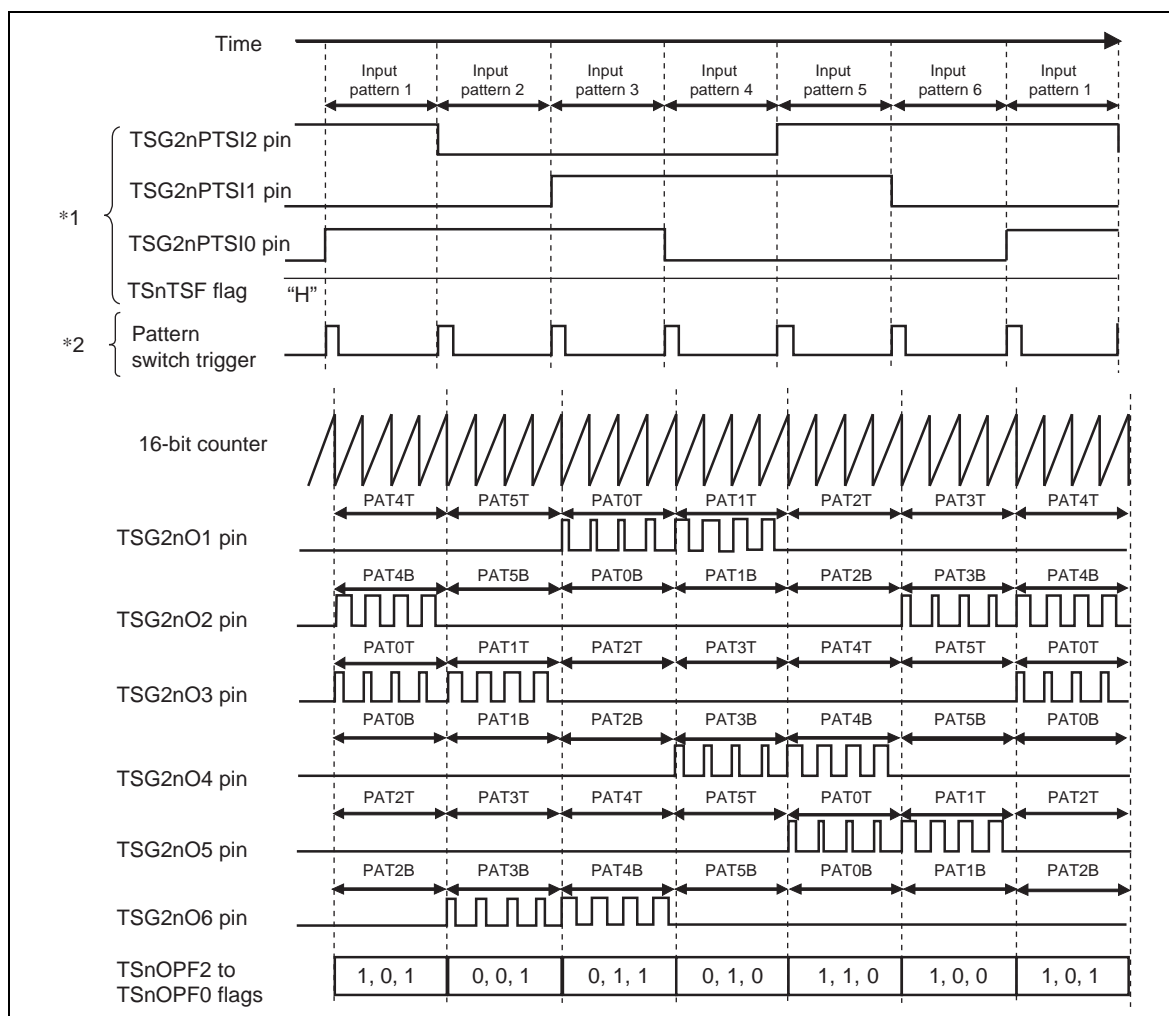

Figure 15-68 Example of Operation in 120-DC Mode (Reverse Rotation: TSnSTR1.TSnTSF = 1 and TSnOPT0.TSnIDC = 1)

Note 1. For pattern switch method (TSnOPT0.TSnPOT = 0)

Note 2. For trigger switch method (TSnOPT0.TSnPOT = 1 and TSnPSS = 1)

Note TSnOPT0.TSnSOC = 0

(6) List of Output Patterns in 120-DC Mode

In 120-DC mode, the output pattern is determined according to the rotation direction and TSnOPT0.TSnIDC.

TSnOPT0		Rotation Direction
TSnPOT	TSnPSS	
0	-	TSnTSF
1	1	TSnPSC

Normal rotation: TSnOPT0.TSnSOC = 0, TSnPSC = 0, TSnPOT = 1, TSnPSS = 1, TSnIDC = 0

The order of pattern switching

Output Pin	TSnOPT1.TSnSPC2 to TSnSPC0*/TSnSTR1.TSnOPF2 to TSnOPF0							
	101	100	110	010	011	001	000	111
TSG2nO1	PAT0T	PAT1T	PAT2T	PAT3T	PAT4T	PAT5T	Low	Low
TSG2nO2	PAT0B	PAT1B	PAT2B	PAT3B	PAT4B	PAT5B	Low	Low
TSG2nO3	PAT4T	PAT5T	PAT0T	PAT1T	PAT2T	PAT3T	Low	Low
TSG2nO4	PAT4B	PAT5B	PAT0B	PAT1B	PAT2B	PAT3B	Low	Low
TSG2nO5	PAT2T	PAT3T	PAT4T	PAT5T	PAT0T	PAT1T	Low	Low
TSG2nO6	PAT2B	PAT3B	PAT4B	PAT5B	PAT0B	PAT1B	Low	Low

Normal rotation: TSnOPT0.TSnSOC = 0, TSnPSC = 0, TSnPOT = 1, TSnPSS = 1, TSnIDC = 1

The order of pattern switching

Output Pin	TSnOPT1.TSnSPC2 to TSnSPC0*/TSnSTR1.TSnOPF2 to TSnOPF0							
	101	100	110	010	011	001	000	111
TSG2nO1	PAT3T	PAT4T	PAT5T	PAT0T	PAT1T	PAT2T	Low	Low
TSG2nO2	PAT3B	PAT4B	PAT5B	PAT0B	PAT1B	PAT2B	Low	Low
TSG2nO3	PAT1T	PAT2T	PAT3T	PAT4T	PAT5T	PAT0T	Low	Low
TSG2nO4	PAT1B	PAT2B	PAT3B	PAT4B	PAT5B	PAT0B	Low	Low
TSG2nO5	PAT5T	PAT0T	PAT1T	PAT2T	PAT3T	PAT4T	Low	Low
TSG2nO6	PAT5B	PAT0B	PAT1B	PAT2B	PAT3B	PAT4B	Low	Low

Note * When TSnSPC2 to TSnSPC0 are written to while TSnPOT = 1, the output pattern changes. Thereafter, when a pattern switch trigger is generated on rising of the TSnOPCI0 and TSnOPCI1 signals, the output is switched according to the order of pattern switching. In this case, TSnSPC2 to TSnSPC0 remain unchanged even if the output pattern is switched.

Note 1. PAT0T to PAT5T: PWM output set by TSnCMP1W, TSnCMP5W, and TSnCMP9W

Note 2. PAT0B to PAT5B: PWM output set by TSnCMP3W, TSnCMP7W, and TSnCMP11W

Reverse rotation: TSnOPT0.TSnSOC = 0, TSnPSC = 1, TSnPOT = 1,
TSnPSS = 1, TSnIDC = 0

The order of pattern switching

Output Pin	TSnOPT1.TSnSPC2 to TSnSPC0*/TSnSTR1.TSnOPF2 to TSnOPF0							
	101	100	110	010	011	001	000	111
TSG2nO1	PAT1T	PAT0T	PAT5T	PAT4T	PAT3T	PAT2T	Low	Low
TSG2nO2	PAT1B	PAT0B	PAT5B	PAT4B	PAT3B	PAT2B	Low	Low
TSG2nO3	PAT3T	PAT2T	PAT1T	PAT0T	PAT5T	PAT4T	Low	Low
TSG2nO4	PAT3B	PAT2B	PAT1B	PAT0B	PAT5B	PAT4B	Low	Low
TSG2nO5	PAT5T	PAT4T	PAT3T	PAT2T	PAT1T	PAT0T	Low	Low
TSG2nO6	PAT5B	PAT4B	PAT3B	PAT2B	PAT1B	PAT0B	Low	Low

Reverse rotation: TSnOPT0.TSnSOC = 0, TSnPSC = 1, TSnPOT = 1,
TSnPSS = 1, TSnIDC = 1

The order of pattern switching

Output Pin	TSnOPT1.TSnSPC2 to TSnSPC0*/TSnSTR1.TSnOPF2 to TSnOPF0							
	101	100	110	010	011	001	000	111
TSG2nO1	PAT4T	PAT3T	PAT2T	PAT1T	PAT0T	PAT5T	Low	Low
TSG2nO2	PAT4B	PAT3B	PAT2B	PAT1B	PAT0B	PAT5B	Low	Low
TSG2nO3	PAT0T	PAT5T	PAT4T	PAT3T	PAT2T	PAT1T	Low	Low
TSG2nO4	PAT0B	PAT5B	PAT4B	PAT3B	PAT2B	PAT1B	Low	Low
TSG2nO5	PAT2T	PAT1T	PAT0T	PAT5T	PAT4T	PAT3T	Low	Low
TSG2nO6	PAT2B	PAT1B	PAT0B	PAT5B	PAT4B	PAT3B	Low	Low

Note * When TSnSPC2 to TSnSPC0 are written to while TSnPOT = 1, the output pattern changes. Thereafter, when a pattern switch trigger is generated by rising of TSnOPCI0 and TSnOPCI1 signals, the output is switched according to the pattern switch order. In this case, TSnSPC2 to TSnSPC0 remain unchanged even if the output pattern is switched.

- Note 1. PAT0T to PAT5T: PWM output set by TSnCMP1W, TSnCMP5W, and TSnCMP9W
- Note 2. PAT0B to PAT5B: PWM output set by TSnCMP3W, TSnCMP7W, and TSnCMP11W

(7) Operation Start Timing in 120-DC Mode

In 120-DC mode, when trigger switch control (TSnOPT0.TSnPOT = 1) is used, pattern set with TSnOPT1.TSnSPC2 to TSnSPC0, rotation direction, and TSnOPT0.TSnIDC can be output. However, when pattern switch control (TSnPOT = 0) is used, the pattern of the TSG2nPTSI2 to TSG2nPTSI0 pins can be detected but rotation direction (TSnSTR1.TSnTSF) cannot be determined. Therefore, set the rotation direction in TSnPSC when TSnTE is 0. The TSnPSC set value is loaded to TSnTSF, and the value can be used for the initial pattern setting.

TSnOPT0.TSnSOC = 0, TSnPSC = 0, TSnPOT = 0, TSnIDC = 0

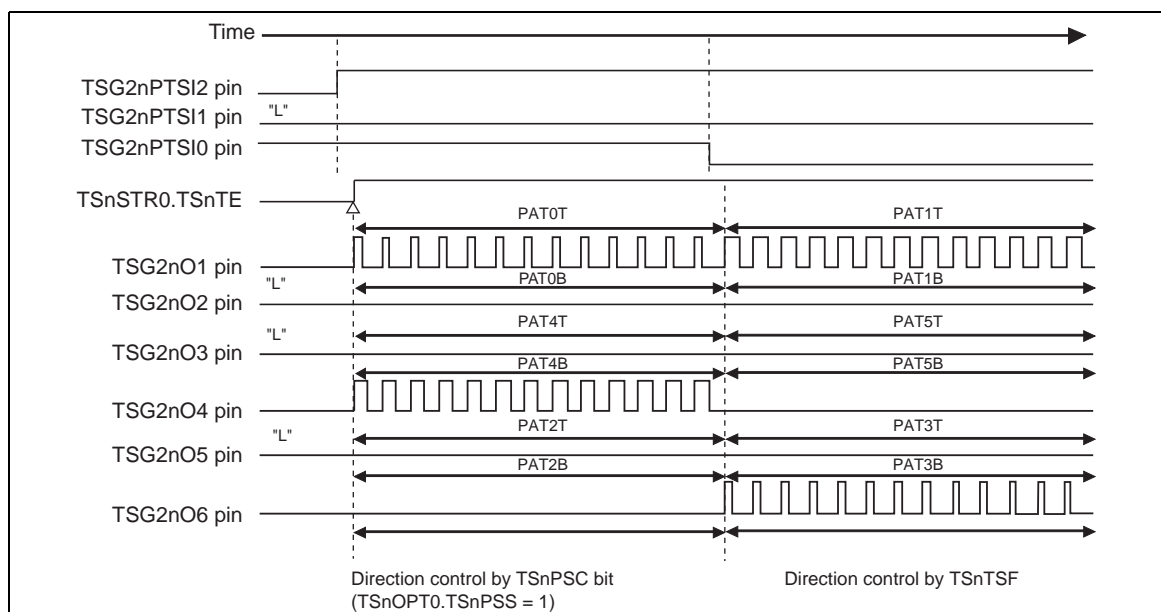

Figure 15-69 Control when Timer Output Starts in Normal Rotation (when Normal Pattern is Input)

TSnOPT0.TSnSOC = 0, TSnPSC = 1, TSnPOT = 0, TSnIDC = 1

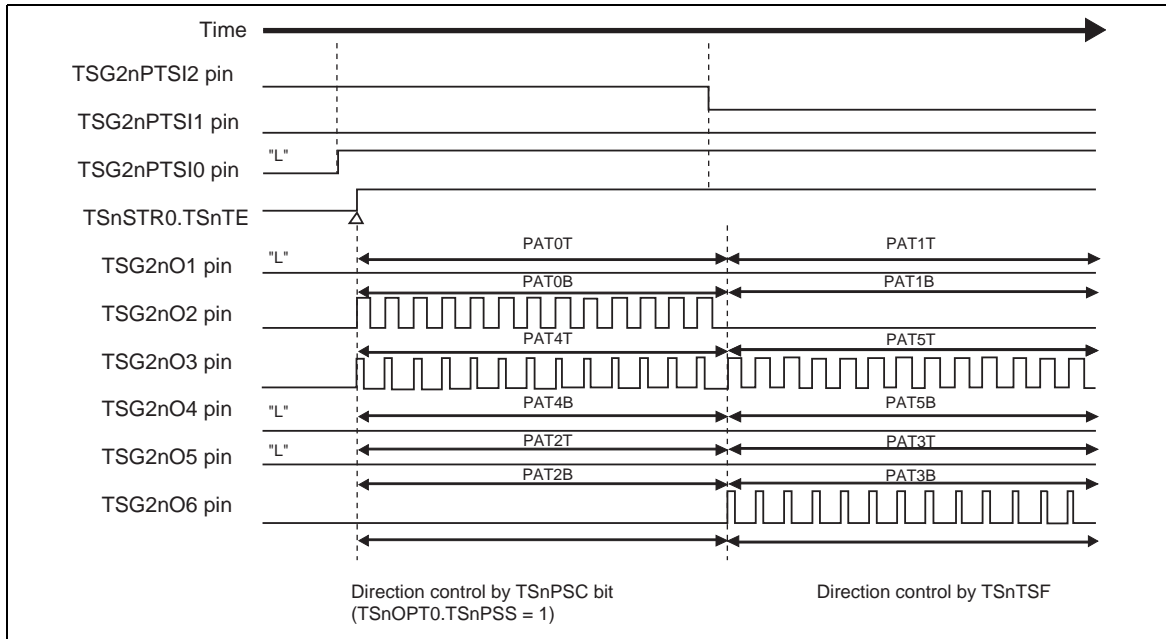

Figure 15-70 Control when Timer Output Starts in Reverse Rotation (when Normal Pattern is Input)

TSnOPT0.TSnSOC = 0, TSnPSC = 0, TSnPOT = 0, TSnIDC = 0

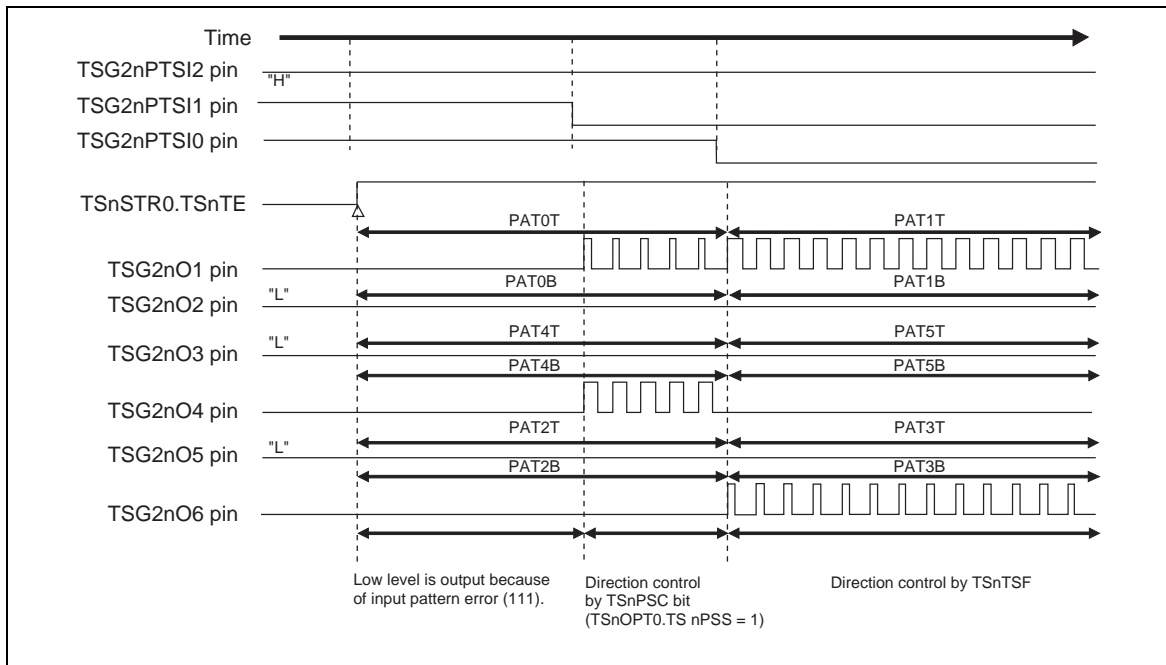

Figure 15-71 Control when Timer Output Starts in Normal Rotation (when Error Pattern is Input)

TSnOPT0.TSnSOC = 0, TSnPSC = 1, TSnPOT = 0, TSnIDC = 1

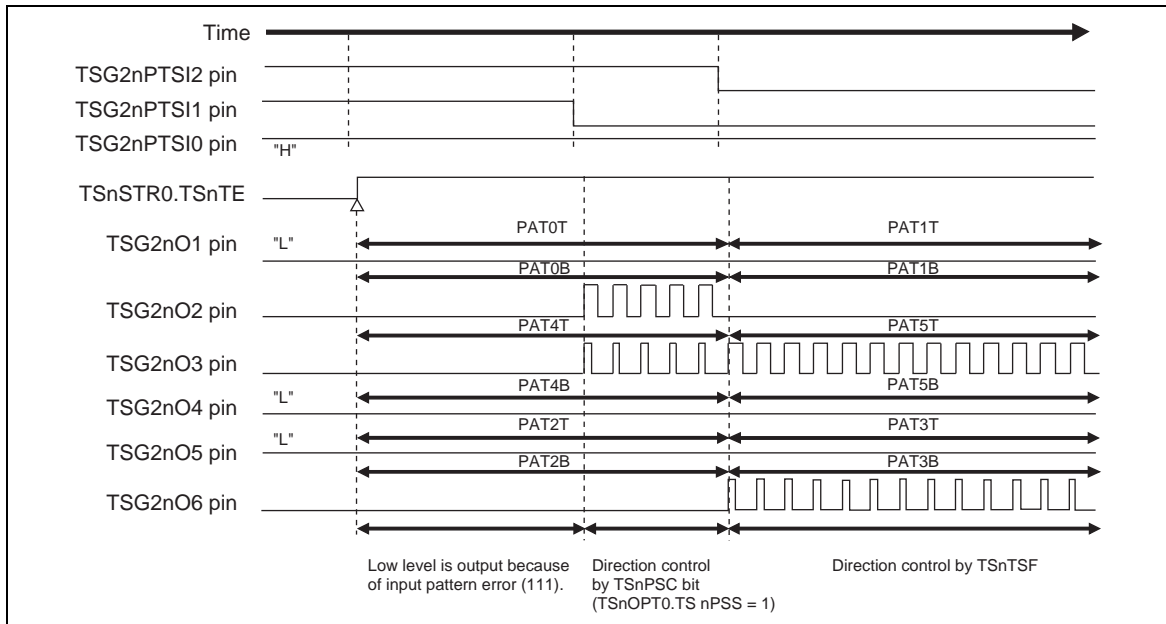

Figure 15-72 Control when Timer Output Starts in Reverse Rotation (when Error Pattern is Input)

(8) Output Switch Timing in 120-DC Mode

As shown in Figure 15-73 to Figure 15-76, in 120-DC mode, the external switch timing for output pattern (TSnOPCI0 and TSnOPCI1 signals, and TSG2nPTS12 to TSG2nPTS10 pins) is input irrespective of the 16-bit counter operation. The output is switched to the new pattern by clearing the 16-bit counter using the pattern switch timing signal applied from outside.

In the pattern switch method, if a change in TSG2nPTS12 to TSG2nPTS10 pins occurs consecutively within one period, the value edge detected immediately before the period match timing is reflected to PWM output in the following periods. In the trigger switch method, if TSnOPCI0 and TSnOPCI1 signal trigger is input for several times within one period, the output pattern is switched by clearing the 16-bit counter each time the trigger is accepted.

In the trigger switch method, if a rewrite to TSnOPT1.TSnSPC2 to TSnSPC0 and TSnOPCI0 and TSnOPCI1 trigger occur within one period, TSnSPC2 to TSnSPC0 are rewritten. If TSnSPC2 to TSnSPC0 are rewritten more than once within one period, the output pattern is switched by clearing the 16-bit counter each time TSnSPC2 to TSnSPC0 are rewritten.

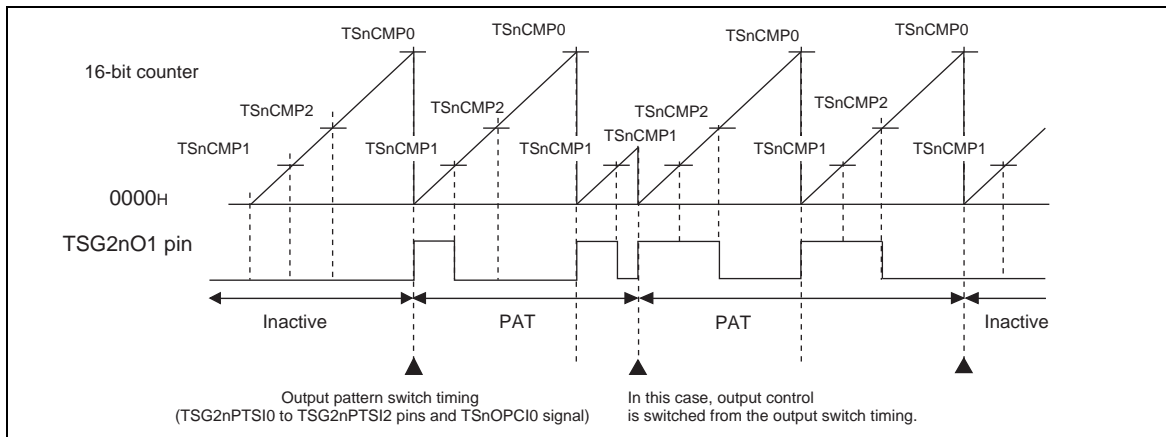

Figure 15-73 Output Switch Example (TSG2nPTS12 to TSG2nPTS10 Pins and TSnOPCI0 and TSnOPCI1 Signal Trigger Input)

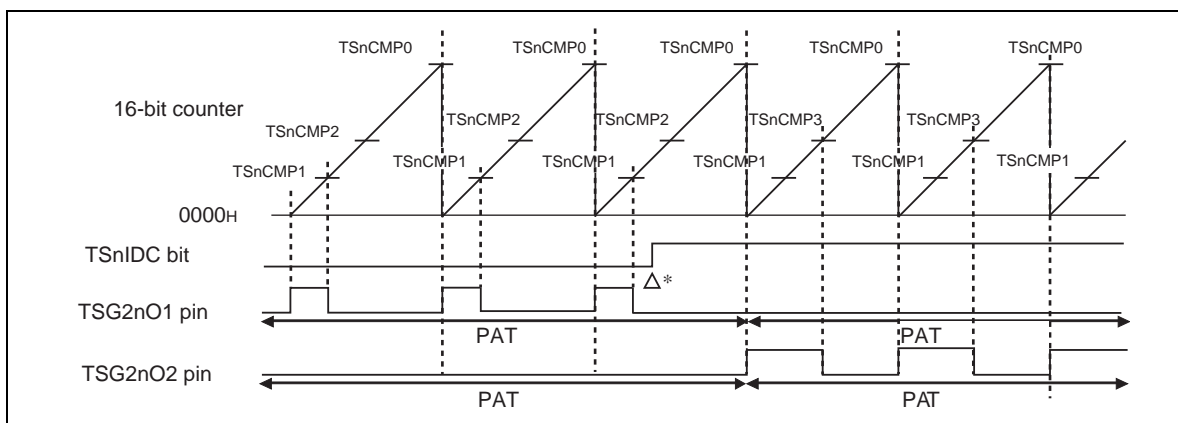

Figure 15-74 Output Switch Example (Switched by TSnOPT0.TSnIDC)

Note * When the pattern is switched here, output control is switched in the next period.

Note If a change in the TSG2nPTS12 to TSG2nPTS10 pins occurs by the time the next period when output control is switched by the TSnIDC bit, the 16-bit counter is cleared and output control is switched.

TSnOPT0.TSnPOT = 1

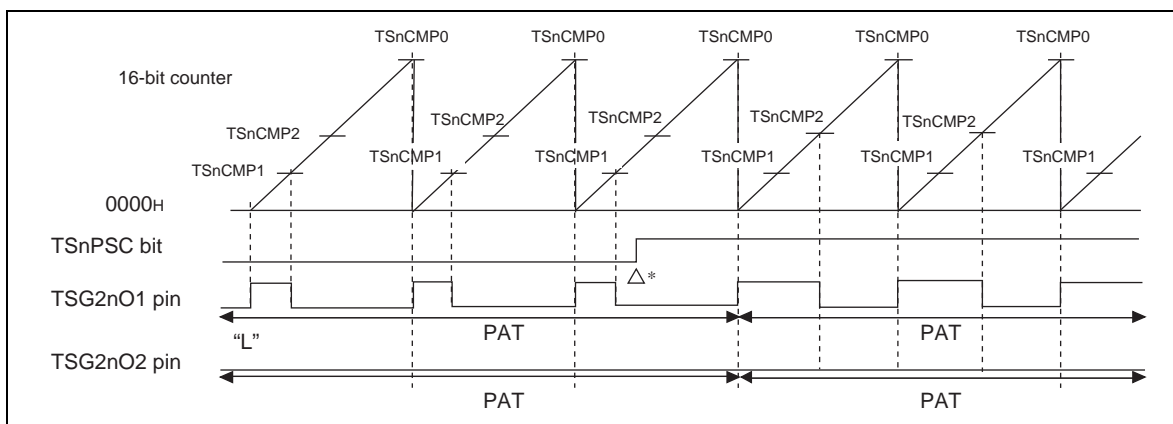

Figure 15-75 Output Switch Example (Switched by TSnOPT0.TSnPSC)

Note * When the pattern is switched here, output control is switched from the next period.

TSnOPT0.TSnSOC = 0, TSnPOT = 1

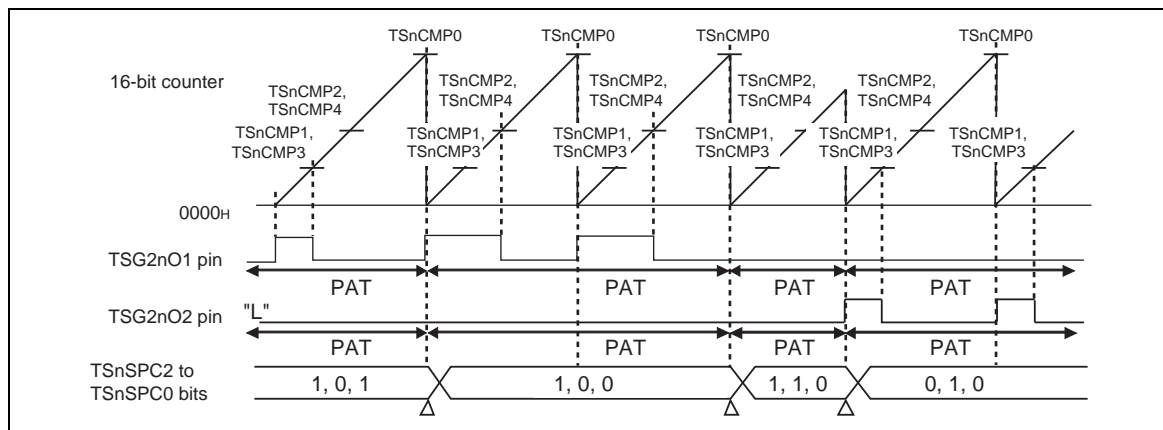

Figure 15-76 Output Switch Example (Switched by TSnOPT1.TSnSPC2 to TSnSPC0)

Note Δ: Write access

(9) Compare Register Rewrite Timing in 120-DC Mode

Example of operation when TSnCMP1 is reloaded (rewritten simultaneously) is shown below.

Figure 15-77 shows an output example when TSnCMP1 is rewritten. After TSnCMP1 is changed, data is not transferred to the TSnCMP1 buffer register (changed data is not valid) until the next reload timing; therefore, the specified output waveform can be obtained. However, do not write to TSnCMP1 again while the reload is suspended (period from when TSnCMP1 is changed to when simultaneous rewrite is executed). Be sure to read the reload request flag (TSnRSF) to confirm that the flag is 0, and write data to TSnCMP1.

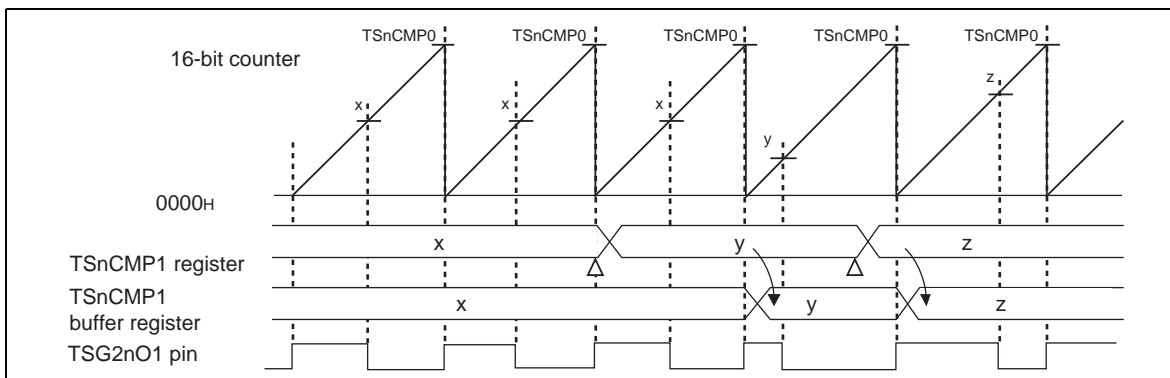

Figure 15-77 Output Example when TSnCMP1 is Rewritten

Note Δ: Write access

(10) Dead Time Control in 120-DC Mode

In 120-DC mode, the dead time is controlled on falling of each phase, and the dead time is added.

The dead time set in TSnDTC1 is inserted on falling of the positive phase, and the dead time set in TSnDTC0 is inserted on falling of the inverse phase.

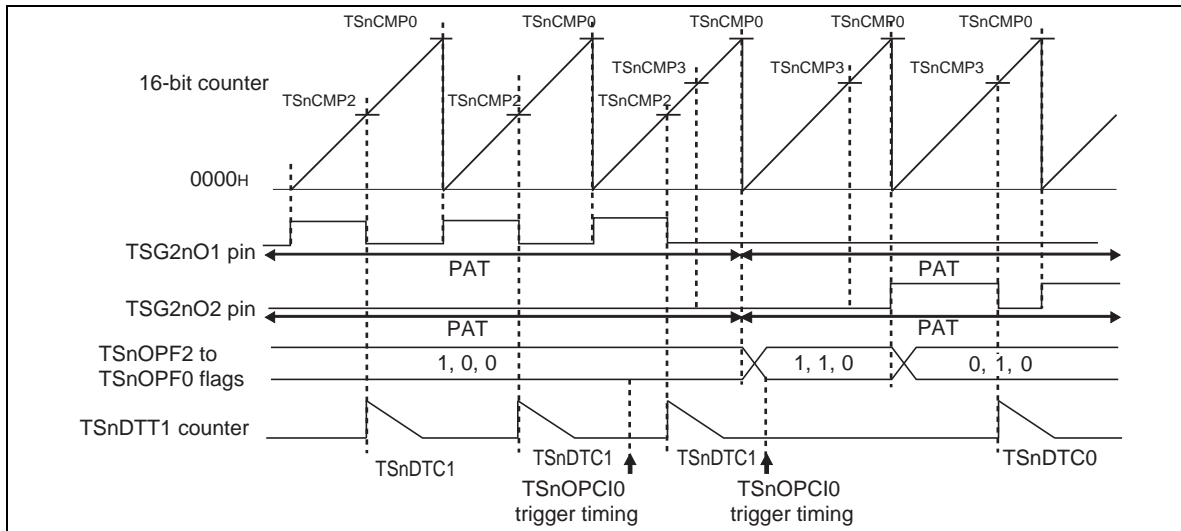

Figure 15-78 Output Switch Example

Caution The dead time control method may affect the timer output. The timer output may not have the specified active level width due to the dead time control under the following conditions:

- When noise is generated on the input pattern in the pattern switch method
- When a change in the input pattern occurs earlier than the PWM period in the pattern switch method
- When TSnOPT1.TSnSPC2 to TSnSPC0 are changed and the output pattern is forcibly changed in the trigger switch method
- When switch method is changed
- When the current direction control bit (TSnOPT0.TSnIDC) is changed
- When the software output control function is used

(11) Output Switch in 120-DC Mode

In 120-DC mode, the output pattern can be controlled by writing values to TSnOPT1.TSnSPC2 to TSnSPC0 when the trigger switch method (TSnOPT0.TSnSTE = 1, and TSnPOT = 1) is used. The dead time is secured by hardware at the switch timing.

Caution When 111_B or 000_B is written to TSnSPC2 to TSnSPC0, the TSG2nO1 to TSG2nO6 pins are driven low.

(12) Operation when Noise is Generated in TSG2nPTSI2 to TSG2nPTSI0 Pins in 120-DC Mode

Input to the TSG2nPTSI2 to TSG2nPTSI0 pins is assumed to be the hall sensor signals of the brushless DC motor. Depending on the system, a noise may be generated on the TSG2nPTSI2 to TSG2nPTSI0 pins. Operation when a noise is generated is described below.

For system product design, be sure to insert a noise filter circuit between the hall sensor and the TSG2nPTSI2 to TSG2nPTSI0 pins.

Figure 15-80 shows a case when a noise is generated on the TSG2nPTSI2 to TSG2nPTSI0 pins during operation with the pattern switch method used.

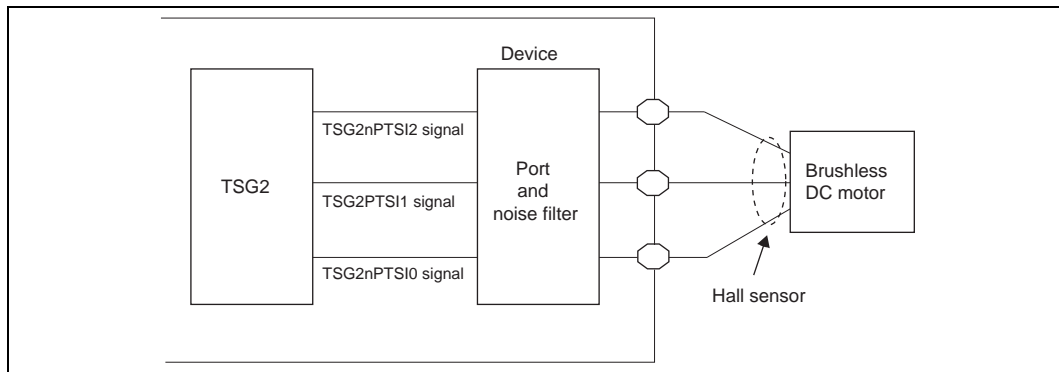

Figure 15-79 Example of Noise Filter Circuit Connection

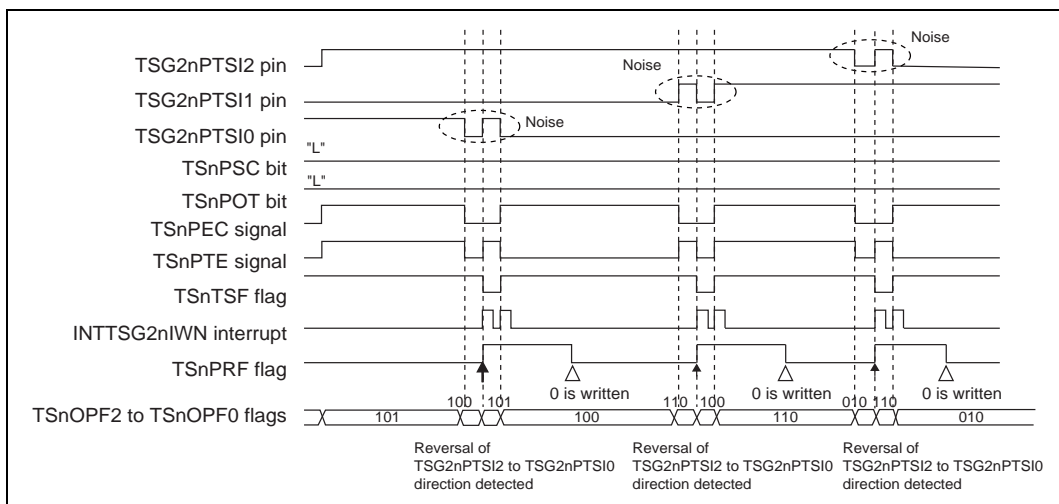

Figure 15-80 Example of Noise Generation at Level Change in TSG2nPTSI2 to TSG2nPTSI0 Pins (Pattern Switch Method)

(a) Change Timing of Input Pattern Change Detection Signal (TSnPTE)

- The TSnPTE signal toggles when the input pattern (TSG2nPTSI2 to TSG2nPTSI0 pins) changes.

Caution Be sure to specify the rotation direction by TSnPSC (TSnPSS = 1 in TSnOPT0) in TSnOPT0.

(when TSnPSC = 0)

		TSG2nPTSI2 to TSG2nPTSI0 Pins after Change							
		000	111	101	100	110	010	011	001
Current TSG2nPTSI2 to TSG2nPTSI0 pins	000	-	-	-	-	-	-	-	-
	111	-	-	-	-	-	-	-	-
	101	-	-	-	Toggle	-	-	-	-
	100	-	-	-	-	Toggle	-	-	-
	110	-	-	-	-	-	Toggle	-	-
	010	-	-	-	-	-	-	Toggle	-
	011	-	-	-	-	-	-	-	Toggle
	001	-	-	Toggle	-	-	-	-	-

(when TSnPSC = 1)

		TSG2nPTSI2 to TSG2nPTSI0 Pins after Change							
		000	111	101	100	110	010	011	001
Current TSG2nPTSI2 to TSG2nPTSI0 pins	000	-	-	-	-	-	-	-	-
	111	-	-	-	-	-	-	-	-
	101	-	-	-	-	-	-	-	Toggle
	100	-	-	Toggle	-	-	-	-	-
	110	-	-	-	Toggle	-	-	-	-
	010	-	-	-	-	Toggle	-	-	-
	011	-	-	-	-	-	Toggle	-	-
	001	-	-	-	-	-	-	Toggle	-

(b) Change Timing of Three-Phase Encode Signal (TSnPEC)

- The TSnPEC signal toggles when input pattern (TSG2nPTSI2 to TSG2nPTSI0 pins) changes.

		TSG2nPTSI2 to TSG2nPTSI0 Pins after Change							
		000	111	101	100	110	010	011	001
Current TSG2nPTSI2 to TSG2nPTSI0 Pins	000	-	-	-	-	-	-	-	-
	111	-	-	-	-	-	-	-	-
	101	-	-	-	Toggle	-	-	-	Toggle
	100	-	-	Toggle	-	Toggle	-	-	-
	110	-	-	-	Toggle	-	Toggle	-	-
	010	-	-	-	-	Toggle	-	Toggle	-
	011	-	-	-	-	-	Toggle	-	Toggle
	001	-	-	Toggle	-	-	-	Toggle	-

(c) Change Timing of TSG2nO1 to TSG2nO6 Pins

- When the pattern switch method is used, the output pattern changes when the input signal of the TSG2nPTSI2 to TSG2nPTSI0 pins* changes. The output is also switched when two or more pins change simultaneously.
- When the trigger switch method is used, the output pattern changes at the rising edge of the TSnOPCI0 and TSnOPCI1 signals. The output also changes when data is written to TSnSPC2 to TSnSPC0* in TSnOPT0.

Note * When the input pattern changes to 000 or 111, the TSG2nO1 to TSG2nO6 pins are driven low.

(d) Change Timing of TSnTSF Flag

- The TSnTSF flag toggles when the input pattern (TSG2nPTSI2 to TSG2nPTSI0 pins) changes.

		TSG2nPTSI2 to TSG2nPTSI0 Pins after Change							
		000	111	101	100	110	010	011	001
Current TSG2nPTSI2 to TSG2nPTSI0 Pins	000	-	-	-	-	-	-	-	-
	111	-	-	-	-	-	-	-	-
	101	-	-	-	0	-	-	-	1
	100	-	-	1	-	0	-	-	-
	110	-	-	-	1	-	0	-	-
	010	-	-	-	-	1	-	0	-
	011	-	-	-	-	-	1	-	0
	001	-	-	0	-	-	-	1	-

(e) Set Timing of TSnNDF Flag

- The TSnNTF flag is set when two or more pins of the TSG2nPTSI2 to TSG2nPTSI0 pins change simultaneously, and cleared when 1 is written to the TSnNDR bit. The TSnNDF flag is valid when 1 is set to the TSnNDC bit.

(f) Set Timing of TSnPRF Flag

- The TSnPRF flag is set when the TSnTSF flag changes, and cleared when 1 is written to the TSnPRR bit. The TSnPRF flag is valid when 1 is set to the TSnPRC bit.

(g) Set Timing of TSnPEF Flag

- The TSnPRF flag is set when 000 or 111 is input to the TSG2nPTSI2 to TSG2nPTSI0 pins, and cleared when 1 is written to the TSnPER bit. The TSnPEF flag is valid when the TSnPEC bit is set to 1.

(13) Basic Control Flow in 120-DC Mode

In 120-DC mode, there are eight control states as listed in Figure 15-76.

When $TSnOPT0.TSnSTE = 1$ and $TSnPOT = 0$, the pattern switch method is used for 120-DC control.

This is defined as fixed phase control. The fixed phase control should be performed considering the factors such as delay from the hall sensor and delay from sensor level detection to timer output. However, acceleration or deceleration can be performed simply by changing the PWM duty.

When $TSnOPT0.TSnSTE = 1$ and $TSnPOT = 1$, the trigger switch method is selected for 120-DC control.

This is defined as variable phase control. With the variable phase control, the timer output pattern is set prior to the hall sensor; therefore, acceleration or deceleration control according to the phase difference can be performed. However, control is more complex than the fixed phase control because offset width with respect to the hall sensor and the predicted value with respect to the hall sensor should be considered.

When $TSnOPT0.TSnPOT = 1$ and $TSnPSS = 1$, the rotation direction of the motor can be set with $TSnPSC$ in $TSnOPT0$. Set $TSnPSC$ to 0 to set normal rotation, and 1 to set reverse rotation.

$TSnIDC$ in $TSnOPT0$ sets the direction of control (acceleration or deceleration). If the same value as the rotation direction of the motor ($TSnPSC$ set value) is set, acceleration control is set. If the different value from the rotation direction of the motor is set, deceleration control is set.

Table 15-76 Timer Control Status

Status	$TSnPSC$ in $TSnOPT0$	$TSnTSF$ in $TSnSTR1$	$TSnIDC$ in $TSnOPT0$	$TSnPOT$ in $TSnOPT0$	Control
A	-	0	0	0	Normal rotation, acceleration, and fixed phase
B	0	-	0	1	Normal rotation, acceleration, and variable phase
C	0	-	1	1	Normal rotation, deceleration, and variable phase
D	-	0	1	0	Normal rotation, deceleration, and fixed phase
E	-	1	1	0	Reverse rotation, acceleration, and fixed phase
F	1	-	1	1	Reverse rotation, acceleration, and variable phase
G	1	-	0	1	Reverse rotation, deceleration, and variable phase
H	-	1	0	0	Reverse rotation, deceleration, and fixed phase

Generally, the state, when the motor rotation stops, is assumed to be a state of the start and the control begins. First the fixed phase control is used to rotate the motor from the stopped state. Afterwards, to accelerate the motor speed to the fast rotation, the variable phase control is switched on. In combination with encoder timer (ENCA) and the variable phase control, the timer output is changed according to timing that is earlier than the change point of the hall sensors (leading).

To decelerate the motor speed from fast rotation, the direction of control is switched to deceleration control by rewriting only TSnIDC in TSnOPT0. When the rotation count can be reduced to low-speed rotation, the rotation can be placed in the stopped state by decreasing the PWM duty.

State transition is shown in Figure 15-81 and Figure 15-82.

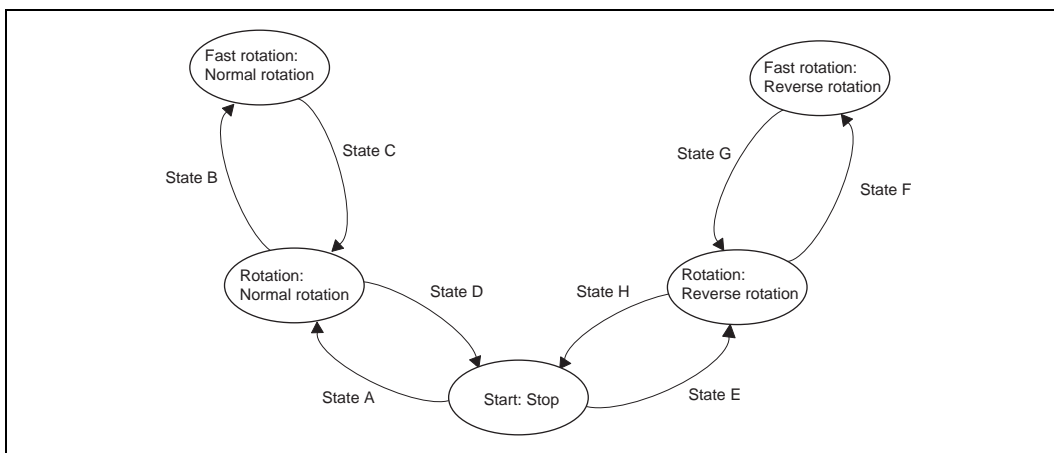

Figure 15-81 State Transition Diagram

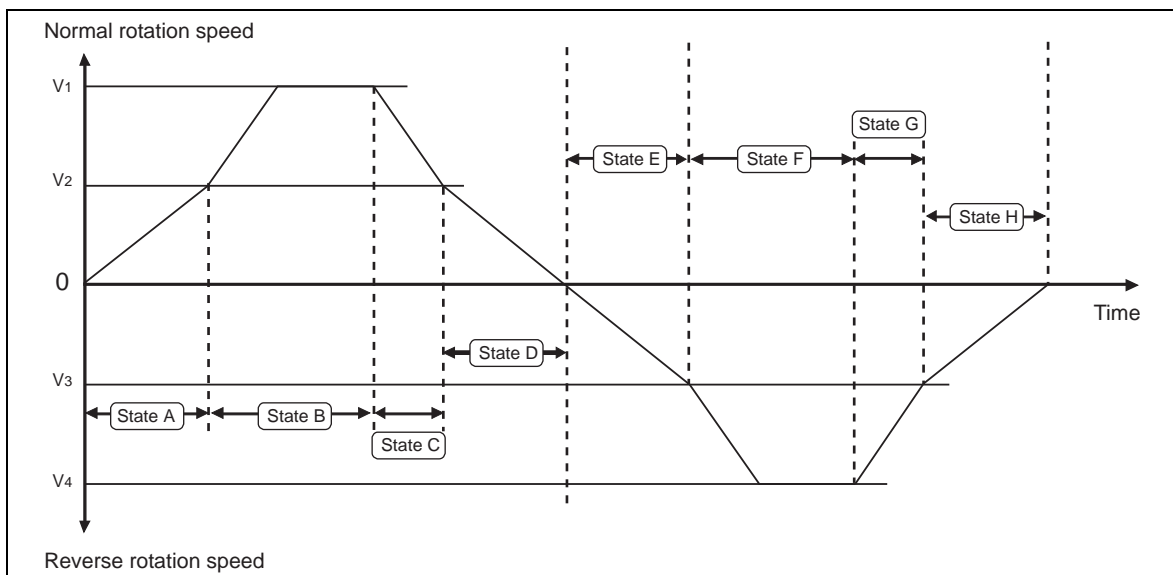

Figure 15-82 Relationship between State Transition and Rotation Speed of Motor

Note V1 and V4: Fast rotation speed of normal rotation and reverse rotation
 V2 and V3: Low rotation speed of normal rotation and reverse rotation

(14) Software Output Control Function in 120-DC Mode

TSnOPT0.TSnSOC and TSnIDC, and TSnOPT1.TSnSPC2 to TSnSPC0 are used in 120-DC mode for timer output control by software.

As shown in Figure 15-83, the output control is switched immediately when TSnSOC is set to 1. If the dead time is set, the period of the dead time period is guaranteed. After that, to switch the output control from software output control to 120-DC control, set TSnSOC to 0. At this timing, output control is retained. When the reload timing is generated, output control is switched to 120-DC mode.

For details on software output control function, see Section 15.11.5, Software Output Control Function.

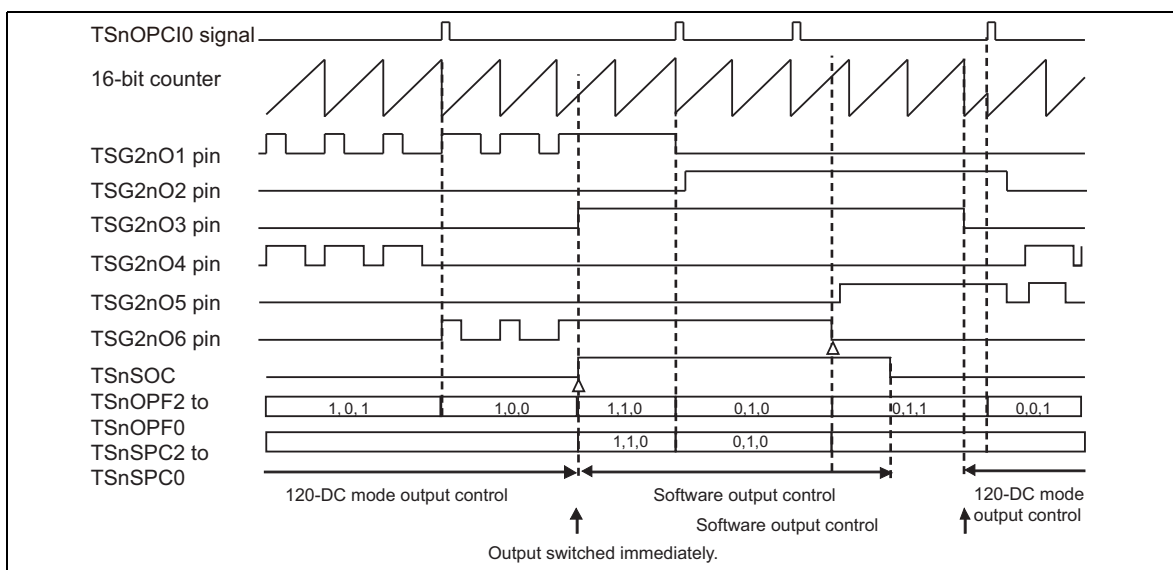
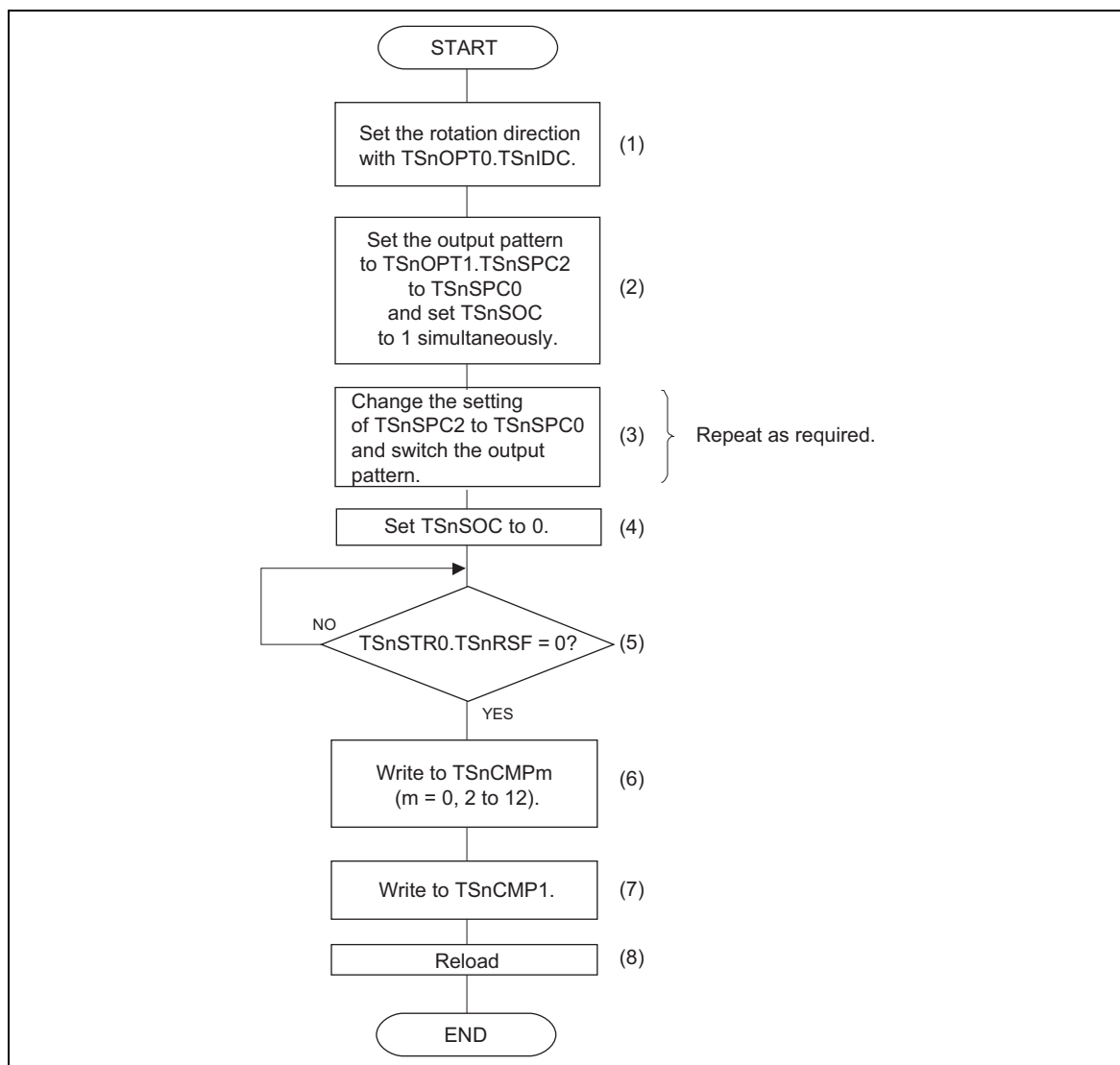

Figure 15-83 Example of Switching from 120-DC Mode to Software Output Control Function

Note Δ: Write access

(a) Procedure for Software Output Control**Figure 15-84 Process Flow of Software Output Control**

The procedure for software output control is described below.

- (1) Set TSnIDC to determine the rotation direction. The phase of the timer output with TSnIDC = 0 is different by 180 degrees from that with TSnIDC = 1. The timer output does not change if only this bit is rewritten using the software output control function. However, if the period match occurs before step (2), the output pattern of 120-DC control changes. So, schedule so as to prevent the period match from occurring before step (2).
- (2) Set the output pattern to TSnSPC2 to TSnSPC0. To enable software output control, set TSnSOC to 1 simultaneously.
- (3) Change the output pattern setting of TSnSPC2 to TSnSPC0 to change the timer output. The registers that can be changed during software control are: TSnTRG1.TSnTT, TSnCTL4 to TSnCTL6, TSnOPT0, TSnOPT1, TSnCMP0 to TSnCMP12, TSnDTC0, and TSnDTC1.
- (4) Confirm that the reload request flag (TSnRSF) = 0. If TSnRFS = 1, do not proceed to the following step until TSnRSF = 0.

-
- (5) By setting TSnSOC = 0 the software control starts to be released (it is not released here yet).
 - (6) After releasing the software output control, set the necessary compare registers. Proceed to the following step when the register setting is not required. Here, change the registers with the reload function.
 - (7) Write to TSnCMP1 to start reloading.
 - (8) Reload is executed and software output is released.

Caution Execute reload after executing steps (4) to (7). When reload cannot be executed, the software output cannot be released.

15.11.5 Software Output Control Function

Software output control function can be used in HT-PWM mode, SP-PWM mode, and 120-DC mode. This function can switch six output patterns for the TSG2nO1 to TSG2nO6 pins using TSnOPT0.TSnSOC, TSnIDC, and TSnOPT1.TSnSPC2 to TSnSPC0.

When TSnSOC is switched from 0 to 1, the output control method of the TSG2nO1 to TSG2nO6 pins is switched to the software output control immediately. On the contrast, when TSnSOC is switched from 1 to 0, the software output control is released at the reload timing.

Table 15-77 Register Description on Software Output Control Function

Register	Setting
TSnOPT0.TSnSOC	TSnSOC = 1
TSnOPT0.TSnSTE	TSnSTE = 0
TSnOPT1.TSnSPC2 to TSnSPC0	Set output patterns listed in Table 15-78 and Table 15-79.
TSnOPT0.TSnIDC	Set output pattern (rotation direction).

Table 15-78 Output Pattern of Software Output Control (TSnOPT0.TSnIDC = 0)

TSnOPT0.TSnSOC = 1, TSnSTE = 0, TSnIDC = 0

Output Pin	TSnSTR1.TSnOPF2 to TSnOPF0							
	101	100	110	010	011	001	000	111
TSG2nO1	ACT	ACT	ACT	INACT	INACT	INACT	INACT	ACT
TSG2nO2	INACT	INACT	INACT	ACT	ACT	ACT	ACT	INACT
TSG2nO3	INACT	INACT	ACT	ACT	ACT	INACT	INACT	ACT
TSG2nO4	ACT	ACT	INACT	INACT	INACT	ACT	ACT	INACT
TSG2nO5	ACT	INACT	INACT	INACT	ACT	ACT	INACT	ACT
TSG2nO6	INACT	ACT	ACT	ACT	INACT	INACT	ACT	INACT

Note ACT: Active level is output.
INACT: Inactive level is output.

Table 15-79 Output Pattern of Software Output Control (TSnOPT0.TSnIDC = 1)

TSnOPT0.TSnSOC = 1, TSnSTE = 0, TSnIDC = 1

Output Pin	TSnSTR1.TSnOPF2-TSnOPF0							
	101	100	110	010	011	001	000	111
TSG2nO1	INACT	INACT	INACT	ACT	ACT	ACT	ACT	INACT
TSG2nO2	ACT	ACT	ACT	INACT	INACT	INACT	INACT	ACT
TSG2nO3	ACT	ACT	INACT	INACT	INACT	ACT	ACT	INACT
TSG2nO4	INACT	INACT	ACT	ACT	ACT	INACT	INACT	ACT
TSG2nO5	INACT	ACT	ACT	ACT	INACT	INACT	ACT	INACT
TSG2nO6	ACT	INACT	INACT	INACT	ACT	ACT	INACT	ACT

Note ACT: Active level is output.
INACT: Inactive level is output.

Section 16 TPBA

16.1 Functions of TPBA_n

Instances This product provides 1 instance of TPBA_n.

Table 16-1 Instances of TPBA

TPBA	
Instances	1
Name	TPBA0

Instances index n Throughout this section, the instances of the TPBA are identified by the index "n" (n = 0), for example TPBA_nCTL for TPBA_n control register.

Buffers index m Buffers are identified by index m (m = 00 to 63).

Register addresses TPBA_n register addresses are given as address offsets from the individual base addresses <TPBA_n_base0> or <TPBA_n_base1>. Table 16-2 shows the base address of TPBA_n.

Table 16-2 TPBA_n Register Base Addresses

TPBA _n	<TPBA _n _base0> Address	<TPBA _n _base1> Address
TPBA0	FF83 2000 _H	FFFF F000 _H

Clock supply TPBA_n is connected to PCLK and is supplied with the PCLK clock signal input as listed below.

Table 16-3 TPBA_n Clock Supply

TPBA _n	Supplied Clock
TPBA0	PCLK

I/O signals The I/O signals of the TPBA are listed in Table 16-4.

Table 16-4 List of TPBA I/O signals

TPBA _n Signal	Function	Connected to
TPB _n O	Timer output	Port
TPBA _n SST	Synchronous start trigger input	PIC (input)

Interrupts The TPBA interrupt requests are listed in Table 16-5.

Table 16-5 List of TPBA Interrupt Requests

TPBA _n Interrupt Request	Function	Connected to
INTTPBA _n IPRD	Period-matched detection interrupt	Interrupt controller DMA
INTTPBA _n IDTY	Duty-cycle-matched detection interrupt	Interrupt controller DMA
INTTPBA _n IPAT	Number-of-patterns matched detection interrupt	Interrupt controller DMA

16.2 Functional Overview

TPBA_n is a 16-bit PWM timer with the duty setting buffer.

- Count clock resolution: Min. 12.5 ns (count clock: 80 MHz)
- 16-bit counter
- 16-bit duty register
- 16-bit period setting register
- 7-bit address counter register
- 7-bit pattern number setting register
- Interrupt request signals
 - Period-matched detection interrupt
 - Duty-cycle-matched detection interrupt
 - Number-of-patterns matched detection interrupt
- Number of duty patterns
 - 64 patterns (16 bits) or 128 patterns (8 bits)
- Automatic duty generation according to the number of patterns
- Output control by software
- The count clock can be selected from PCLK, PCLK/2, PCLK/4, and PCLK/8 according to the prescaler set value.
- Synchronous start with another timer

16.3 Configuration

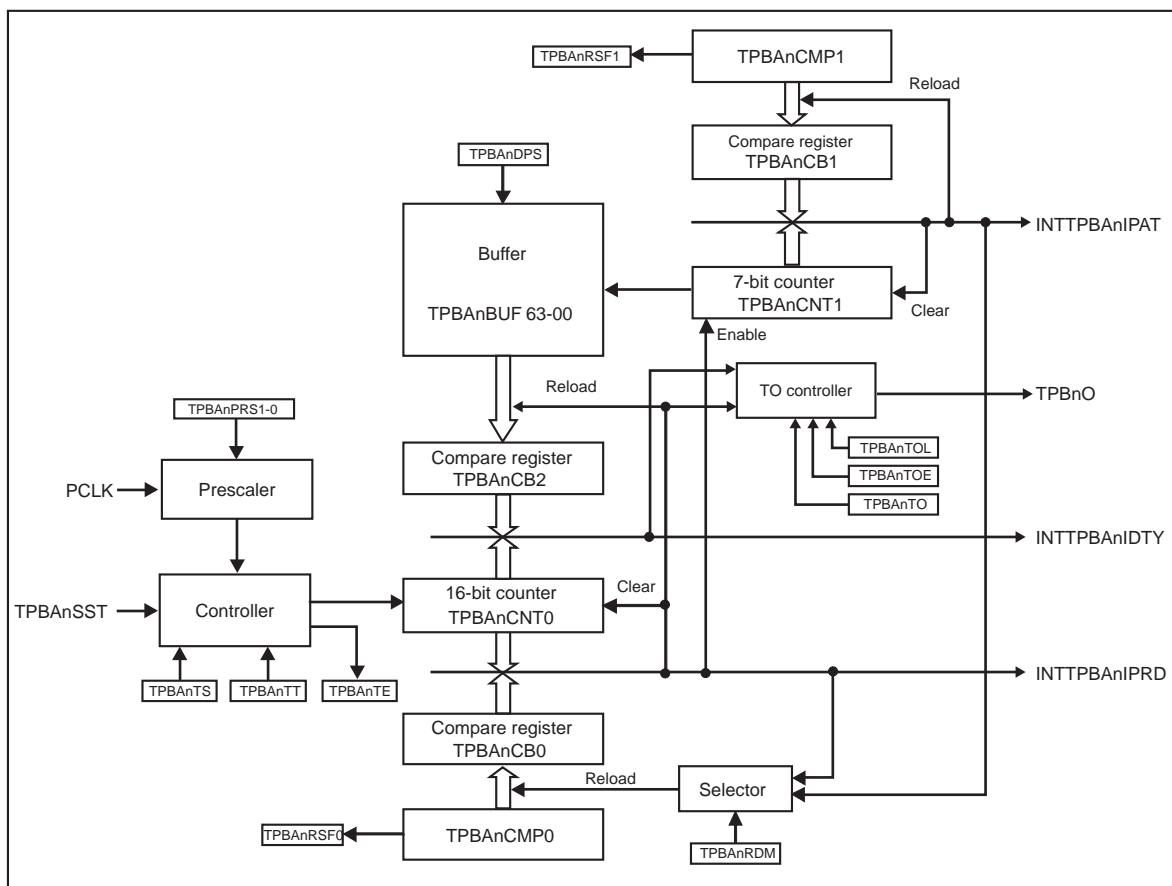

Figure 16-1 Block Diagram of TPBA

16.4 Registers

This section contains a description of all registers of the TPBA_n.

16.4.1 TPBA_n Registers Overview

The TPBA_n is controlled and operated based on the settings of the following registers listed in Table 16-6.

Table 16-6 TPBA_n Registers

Register Name	Symbol	Address
TPBA _n control register	TPBA _n CTL	<TPBA _n _base0> + 200 _H
TPBA _n reload data mode register	TPBA _n RDM	<TPBA _n _base1> + 118 _H
TPBA _n reload status register	TPBA _n RSF	<TPBA _n _base1> + 110 _H
TPBA _n reload data trigger register	TPBA _n RDT	<TPBA _n _base1> + 114 _H
TPBA _n timer output enable register	TPBA _n TOE	<TPBA _n _base1> + 120 _H
TPBA _n timer output register	TPBA _n TO	<TPBA _n _base1> + 11C _H
TPBA _n timer output level register	TPBA _n TOL	<TPBA _n _base1> + 124 _H
TPBA _n period setting register	TPBA _n CMP0	<TPBA _n _base1> + 100 _H
TPBA _n duty setting register	TPBA _n BUFm	<TPBA _n _base1> + 000 _H to 0FC _H
TPBA _n pattern number setting register	TPBA _n CMP1	<TPBA _n _base1> + 104 _H
TPBA _n timer counter register	TPBA _n CNT0	<TPBA _n _base1> + 108 _H
TPBA _n address counter register	TPBA _n CNT1	<TPBA _n _base1> + 10C _H
TPBA _n enable status register	TPBA _n TE	<TPBA _n _base1> + 128 _H
TPBA _n start trigger register	TPBA _n TS	<TPBA _n _base1> + 12C _H
TPBA _n stop trigger register	TPBA _n TT	<TPBA _n _base1> + 130 _H

16.4.2 TPBA_n Registers Details

(1) TPBA_n Control Register (TPBA_nCTL)

This register specifies the operation of the TPBA_n.

Access This register can be read/written in 8-bit units.

Address <TPBA_n_base0> + 200_H

Initial value 00_H

This register is initialized by a reset from any source.

7	6	5	4	3	2	1	0
-	-	TPBA _n PRS1	TPBA _n PRS0	-	-	-	TPBA _n DPS
R	R	R/W	R/W	R	R	R	R/W

Table 16-7 TPBA_nCTL0 Register Contents

Bit Position	Bit Name	Function															
4, 5	TPBA _n PRS [1:0]	Selects the count clock. <table border="1" style="margin-left: 20px;"> <thead> <tr> <th>TPBA_nPRS1</th> <th>TPBA_nPRS0</th> <th>Description</th> </tr> </thead> <tbody> <tr> <td>0</td> <td>0</td> <td>PCLK is selected.</td> </tr> <tr> <td>0</td> <td>1</td> <td>PCLK/2 is selected.</td> </tr> <tr> <td>1</td> <td>0</td> <td>PCLK/4 is selected.</td> </tr> <tr> <td>1</td> <td>1</td> <td>PCLK/8 is selected.</td> </tr> </tbody> </table>	TPBA _n PRS1	TPBA _n PRS0	Description	0	0	PCLK is selected.	0	1	PCLK/2 is selected.	1	0	PCLK/4 is selected.	1	1	PCLK/8 is selected.
TPBA _n PRS1	TPBA _n PRS0	Description															
0	0	PCLK is selected.															
0	1	PCLK/2 is selected.															
1	0	PCLK/4 is selected.															
1	1	PCLK/8 is selected.															
0	TPBA _n DPS	Selects the duty setting pattern mode. 0: 16 bits × 64 patterns mode 1: 8 bits × 128 patterns mode															

Caution This register should be set when the timer is stopped (TPBA_nTE = 0). If this register is erroneously rewritten, set the register again after stopping the timer.

(2) TPBA_n Reload Data Mode Register (TPBA_nRDM)

This register controls the reload timing of the TPBA_n period setting register and TPBA_n timer output level register values.

Access This register can be read/written in 8-bit units.

Address <TPBA_n_base1> + 118_H

Initial value 00_H

This register is initialized by a reset from any source.

7	6	5	4	3	2	1	0
-	-	-	-	-	-	-	TPBA _n RDM0
R	R	R	R	R	R	R	R/W

Table 16-8 TPBA_nRDM Register Contents

Bit Position	Bit Name	Function
0	TPBA _n RDM0	Controls the reload timing of the TPBA _n period setting register (TPBA _n CMP0) and TPBA _n timer output level register (TPBA _n TOL) values. 0: Reloads the values synchronously with a number-of-patterns matched detection interrupt (INTTPBA _n IPAT). 1: Reloads the values synchronously with a period-matched detection interrupt (INTTPBA _n IPRD).

Caution Although this register can be rewritten during operation, the rewritten value is reflected at any time. Accordingly, during operation, this register should be rewritten when the reload request flag (TPBA_nRSF) is 0.

(3) TPBA_n Reload Status Register (TPBA_nRSF)

This register indicates whether or not reload requests from the corresponding registers have been generated.

Access This register can be read in 8-bit units.

Address <TPBA_n_base1> + 110_H

Initial value 00_H

This register is initialized by a reset from any source.

7	6	5	4	3	2	1	0
-	-	-	-	-	-	TPBA _n RSF1	TPBA _n RSF0
R	R	R	R	R	R	R	R

Table 16-9 TPBA_nRFS Register Contents

Bit Position	Bit Name	Function
1	TPBA _n RSF1	Indicates whether or not a reload request from TPBA _n CMP1 has been generated. 0: No reload request generated or reload completed. 1: Reload request has been generated. This bit is set to 1 when 1 is written to the TPBA _n RDT1 bit in the TPBA _n RDT register. This bit is cleared at the timing when reload is performed.
0	TPBA _n RSF0	Indicates whether or not a reload request from TPBA _n CMP0 and TPBA _n TOL has been generated. 0: No reload request generated or reload completed. 1: Reload request has been generated. This bit is set to 1 when 1 is written to the TPBA _n RDT0 bit in the TPBA _n RDT register. This bit is cleared at the timing when reload is performed.

(4) TPBAn Reload Data Trigger Register (TPBAnRDT)

This register enables reload of the register values.

Access This register can be written in 8-bit units. It is always read as 0.

Address <TPBAn_base1> + 114_H

Initial value 00_H

This register is initialized by a reset from any source.

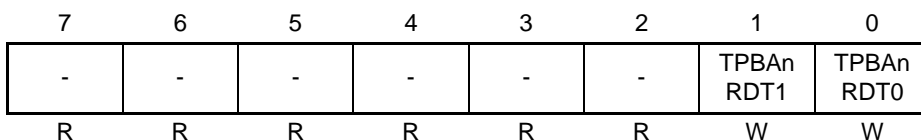

Table 16-10 TPBAnRDT Register Contents

Bit Position	Bit Name	Function
1	TPBAnRDT1	Enables reload of the TPBAnCMP1 values. 0: Write access is ignored. 1: Reload is enabled (TPBAnRSF1 is set to 1). The values are updated simultaneously at the next reload timing (reload).
0	TPBAnRDT0	Enables reload of the TPBAnCMP0 and TPBAnTOL values. 0: Write access is ignored. 1: Reload is enabled (TPBAnRSF0 is set to 1). The values are updated simultaneously at the next reload timing (reload).

(5) TPBAn Timer Output Enable Register (TPBAnTOE)

This register enables or disables the timer output.

Access This register can be read/written in 8-bit units.

Address <TPBAn_base1> + 120_H

Initial value 00_H

This register is initialized by a reset from any source.



Table 16-11 TPBAnTOE Register Contents

Bit Position	Bit Name	Function
0	TPBAnTOE0	Enables or disables the timer output (TPBnO). 0: Disables the timer output based on counter operation. 1: Enables the timer output based on counter operation. <ul style="list-style-type: none"> When the timer output is disabled, the level specified in TPBAnTO is output from the TPBnO pin, and can be controlled by software. When the timer output is enabled, TPBAnTO is set or cleared by the timer operation, and a PWM signal is output. Write access is prohibited (ignored).

(6) TPBA_n Timer Output Register (TPBA_nTO)

This register reads the output settings and the output level.

Access This register can be read/written in 8-bit units.

Address <TPBA_n_base1> + 11C_H

Initial value 00_H

This register is initialized by a reset from any source.

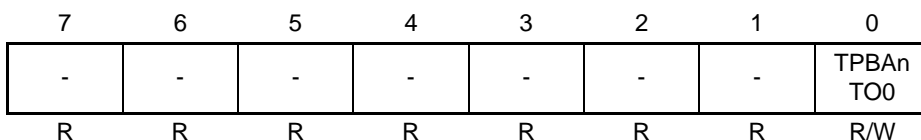

Table 16-12 TPBA_nTO Register Contents

Bit Position	Bit Name	Function
0	TPBA _n TO0	Reads the setting of the TPBA _n O pin output and the output level <ul style="list-style-type: none"> • When the timer output is disabled (TPBA_nTOE.TPBA_nTOE0 = 0) <ul style="list-style-type: none"> 0: Outputs low level. 1: Outputs high level. • When the timer output is enabled (TPBA_nTOE.TPBA_nTOE0 = 1) <ul style="list-style-type: none"> 0: Low level is being output by the timer output. 1: High level is being output by the timer output. When the timer output is enabled, rewrite to this register is ignored.

(7) TPBAn Timer Output Level Register (TPBAnTOL)

This register controls the timer output level.

Access This register can be read/written in 8-bit units.

Address <TPBAn_base1> + 124_H

Initial value 00_H

This register is initialized by a reset from any source.

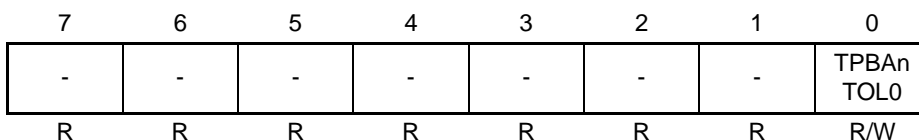

Table 16-13 TPBAnTOL Register Contents

Bit Position	Bit Name	Function
0	TPBAnTOL0	Specifies the active level of the timer output. 0: High 1: Low. <ul style="list-style-type: none"> Setting of this bit is enabled when the timer output is enabled (TPBAnTOE.TPBAnTOE0 = 1). Setting of this bit is reflected when the timer output is started, and change of the output level is reflected at the next reload timing.

Caution This register is a register to be reloaded. Rewrite during timer operation is reflected at the next reload timing. For details on reload, see Section 16.5.2, Compare Register Rewrite Operation.

(8) TPBAn Period Setting Register (TPBAnCMP0)

This is a 16-bit compare register for setting the PWM period.

Access This register can be read/written in 16-bit units.

Address <TPBAn_base0> + 100_H

Initial value 0000_H

This register is initialized by a reset from any source.

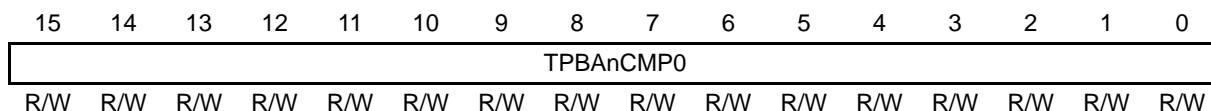

Table 16-14 TPBAnCMP0 Register Setting

Operating Mode	PWM Period	Minimum Value (Period)	Maximum Value (Period)
8 bits	TPBAnCMP0 + 1	1	100 _H
16 bits	TPBAnCMP0 + 1	1	10000 _H

Caution The PWM period is (TPBAnCMP0 + 1) count clock periods. Accordingly, for PWM output with 100% duty cycle, the maximum settable value is FFFE_H (FE_H).

Caution This register is a register to be reloaded. Rewrite during timer operation is reflected at the next reload timing. For details on reload, see Section 16.5.2, Compare Register Rewrite Operation.

(9) TPBAn Duty Setting Register (TPBAnBUFm)

This register is a 16 × 64 buffer register for duty setting.

Access This register can be read/written in 16-bit units.

Address <TPBAn_base1> + 000_H to 0FC_H

Initial value 0000_H

This register is initialized by a reset from any source.

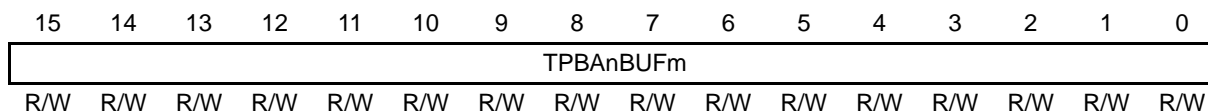

Table 16-15 TPBAnBUFm Register Contents

Bit Position	Bit Name	Function
15 to 0	TPBAnBUFm15 to TPBAnBUFm0	Sets the duty value. This register can set the duty value either in 16 bits × 64 patterns mode (TPBAnDPS = 0) or 8 bits × 128 patterns mode (TPBAnDPS = 1) by setting the TPBAnDPS bit. In either mode, this register is accessed in 16-bit units by the CPU. For details, see Section 16.5.3, Duty Rewrite Operation.

Caution The value set to this register is transferred to the duty setting buffer register (TPBAnCB2) synchronously with a period-matched detection interrupt (INTTPBAnIPRD). Rewrite during timer operation is reflected at any time. For details, see Section 16.5.3, Duty Rewrite Operation.

(10) TPBA_n Pattern Number Setting Register (TPBA_nCMP1)

This register sets the number of PWM output patterns.

Access This register can be read/written in 8-bit units.

Address <TPBA_n_base1> + 104_H

Initial value 00_H

This register is initialized by a reset from any source.

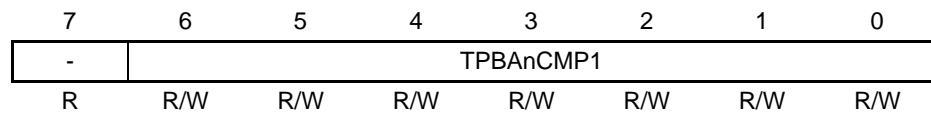

Table 16-16 TPBA_nCMP1 Register Contents

Bit Position	Bit Name	Function
6 to 0	TPBA _n CMP1 [6:0]	Sets the number of patterns within the following range. TPBA _n DPS = 0: 0 to 63 TPBA _n DPS = 1: 0 to 127

Caution This register is a register to be reloaded. Rewrite during timer operation is reflected at the next reload timing. For details on reload, see Section 16.5.2, Compare Register Rewrite Operation.

Caution If 64 or a greater number is set as the number of patterns when the duty setting pattern is in 16 bits × 64 patterns mode (TPBA_nDPS = 0), the address pointer changes from 63 to 00, and the duty value is transferred from 00 again. A number-of-patterns matched detection interrupt signal (INTTPBA_nIPAT) is output by the match of the specified number of patterns and the lower 7-bit values of TPBA_nCNT1.

(11) TPBA_n Timer Counter Register (TPBA_nCNT0)

This register is a 16-bit counter that generates PWM output.

Access This register can only be read in 16-bit units.

Address <TPBA_n_base1> + 108_H

Initial value FFFF_H

This register is initialized by a reset from any source.

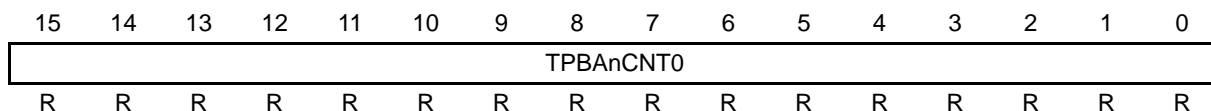

16-bit counter This register is a counter register through which the 16-bit counter value can be read.

(12) TPBA_n Address Counter Register (TPBA_nCNT1)

This register is a counter register that indicates the address pointer to the duty setting register.

Access This register can only be read in 8-bit units.

Address <TPBA_n_base1> + 10C_H

Initial value 00_H

This register is initialized by a reset from any source.

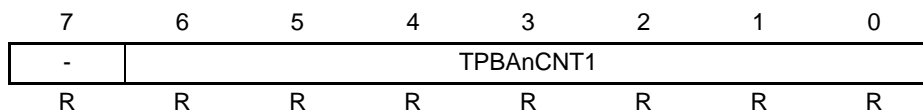

7-bit counter This register indicates TPBA_nBUF_m that holds the duty value to be transferred next.

(13) TPBA_n Enable Status Register (TPBA_nTE)

This register indicates whether the timer counter is operating or stopped.

Access This register can only be read in 8-bit units.

Address <TPBA_n_base1> + 128_H

Initial value 00_H

This register is initialized by a reset from any source.

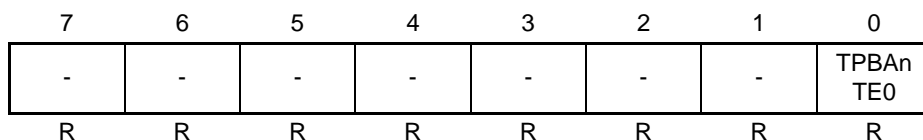

Table 16-17 TPBA_nTE Register Contents

Bit Position	Bit Name	Function
0	TPBA _n TE0	Indicates whether the timer counter is operating or stopped. 0: The timer counter is stopped. 1: The timer counter is operating. <ul style="list-style-type: none"> The TPBA_nTE0 bit is set to 1 when 1 is written to the TPBA_nTS bit or when a synchronous start trigger is input. The TPBA_nTE0 bit is cleared to 0 when 1 is written to the TPBA_nTT bit.

(14) TPBA_n Start Trigger Register (TPBA_nTS)

This register controls the timer counter start trigger.

Access This register can only be written in 8-bit units. It is always read as 0.

Address <TPBA_n_base1> + 12C_H

Initial value 00_H

This register is initialized by a reset from any source.

7	6	5	4	3	2	1	0
-	-	-	-	-	-	-	TPBA _n TS0
R	R	R	R	R	R	R	W

Table 16-18 TPBA_nTS Register Contents

Bit Position	Bit Name	Function
0	TPBA _n TS0	This bit is a trigger bit that enables the timer counter. 0: Write access is ignored. 1: Starts counting (TPBA _n TE = 1).

Caution Write access to this register during counting (TPBA_nTE = 1) is ignored.

(15) TPBA_n Stop Trigger Register (TPBA_nTT)

This register controls the timer counter stop trigger.

Access This register can only be written in 8-bit units. It is always read as 0.

Address <TPBA_n_base1> + 130_H

Initial value 00_H

This register is initialized by a reset from any source.

7	6	5	4	3	2	1	0
-	-	-	-	-	-	-	TPBA _n TT0
R	R	R	R	R	R	R	W

Table 16-19 TPBA_nTT Register Contents

Bit Position	Bit Name	Function
0	TPBA _n TT0	This bit is a trigger bit that disables the timer counter. 0: Write access is ignored. 1: Disables counting (TPBA _n TE = 0).

16.5 Basic Operation

16.5.1 Basic Operation of Counter

(1) Basic Operation of 16-Bit Counter (TPBAnCNT0)

- Counting start** The 16-bit counter (TPBAnCNT0) starts counting from the initial value FFFF_H.
- Counter clear** The 16-bit counter is cleared by the match of the counter value and the buffer register (TPBAnCB0) set value of TPBAnCMP0.
- Counter read during counting** The 16-bit counter value during counting can be read through TPBAnCNT0.

(2) Basic Operation of 7-Bit Counter (TPBAnCNT1)

- Counting start** The 7-bit counter (TPBAnCNT1) is initialized to 00_H and starts counting. Subsequently, the counter value is incremented synchronously with a period-matched detection interrupt (INTTPBAnIPRD).
- Counter clear** The 7-bit counter is cleared by the match of the counter value and the buffer register (TPBAnCB1) set value of TPBAnCMP1.
- Counter read during counting** The 7-bit counter value during counting can be read through TPBAnCNT1. The read value indicates TPBAnBUFm in which the duty value to be transferred next is stored.

16.5.2 Compare Register Rewrite Operation

The following registers are rewritten by reload.

- TPBAnCMP0
- TPBAnCMP1
- TPBAnTOL

**Reload mode
(simultaneous
rewrite function)**

Writing to TPBAnRDT enables reload of the registers corresponding to the set bits (sets the reload request flag (TPBAnRSF.TPBAnRSFk)), and the values of all the pertinent registers are updated simultaneously at the next reload timing (reload).

The reload timing of TPBAnCMP0 and TPBAnTOL is set by TPBAnRDM.

The reload timing of TPBAnCMP1 is the match timing (INTTPBAnIPAT) of the 7-bit counter (TPBAnCNT1) and the buffer register (TPBAnCB1) of TPBAnCMP1.

The registers to be reloaded should be rewritten when the reload request flag (TPBAnRFS.TPBAnRSFk) is 0.

Note: k = 0, 1

Setting Flow for Registers to Be Reloaded

The rewritten values of the registers to be reloaded (TPBAnCMP0, TPBAnCMP1, and TPBAnTOL) can be transferred to the respective buffer registers simultaneously at the reload timing.

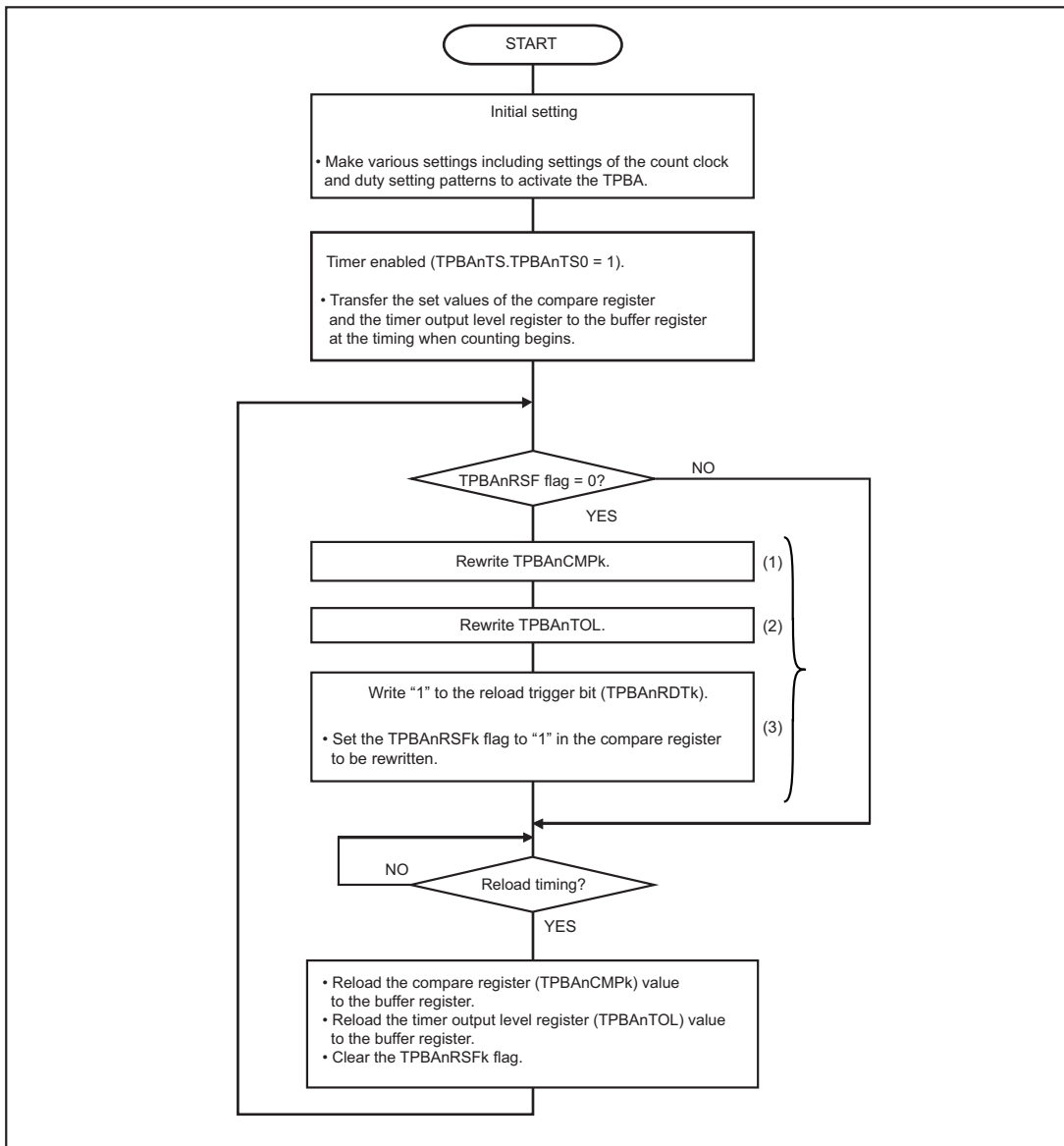

Figure 16-2 Basic Operation Flow of Reload (Simultaneous Rewrite Function)

Note: k = 0, 1

Caution Setting the TPBAnRDTk bit to 1 enables reload. Accordingly, the TPBAnRDTk bit should be rewritten after the registers to be reloaded have been rewritten.

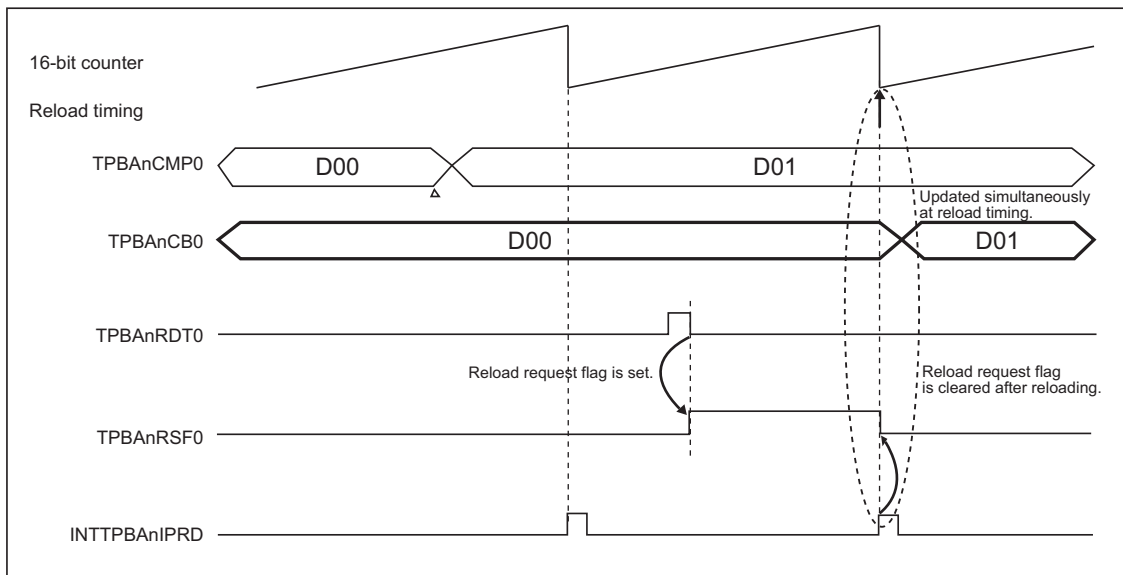

Figure 16-3 Simultaneous Rewrite Timing (TPBAnDPS = 0, TPBAnRDM = 0, and TPBAnTOL = 0)

16.5.3 Duty Rewrite Operation

TPBAnBUFm can be rewritten during operation.

The rewritten setting is reflected immediately.

(1) TPBAnBUFm Setting Flow

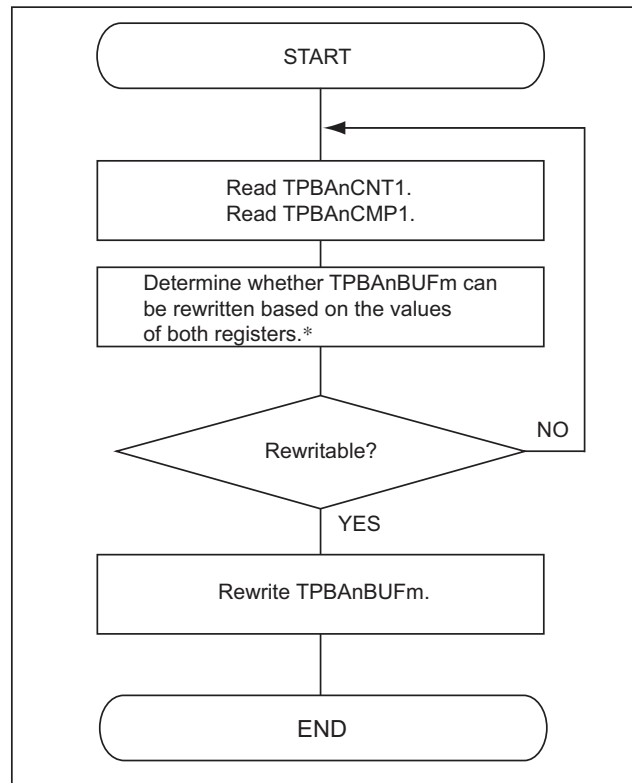

Figure 16-4 Basic Rewrite Flow of TPBAnBUFm

Note * Since TPBAnBUFm can be written at any time, it is recommended that this register is rewritten during last duty cycle output (TPBAnCNT1 = 00_H) of the pattern period (the number of patterns specified by TPBAnCMP1).

(2) Access to TPBAnBUFm

TPBAnBUFm is accessed in 16 bit units. The following shows the access in 16 bits × 64 patterns mode and the access in 8 bits × 128 patterns mode.

- In 16 bits × 64 patterns mode (TPBAnDPS = 0)

This register is accessed by the CPU in units of one 16-bit pattern.

15		0
	Pattern 64	00FC _H
	Pattern 63	00F8 _H
	:	:
	Pattern 3	0008 _H
	Pattern 2	0004 _H
	Pattern 1	0000 _H

- In 8 bits × 128 patterns mode (TPBAnDPS = 1)

This register is accessed by the CPU in units of two 8-bit patterns.

15		0	
	Pattern 128	Pattern 127	00FC _H
	Pattern 126	Pattern 125	00F8 _H
	:	:	:
	Pattern 6	Pattern 5	0008 _H
	Pattern 4	Pattern 3	0004 _H
	Pattern 2	Pattern 1	0000 _H

(3) Relationship between TPBAnCNT1 Read Value and TPBAnBUFm

The duty value of the currently output PWM waveform can be obtained by reading the TPBAnCNT1 count value during operation. TPBAnBUFm in which the currently output duty value is stored can be found by one of the following formulas.

TPBAnDPS0 Bit	Formula		
	TPBAnCNT1 \neq 00 _H		TPBAnCNT1 = 00 _H
0: 16 bits \times 64 patterns mode	(1) TPBAnCNT1 - 01 _H		(2) TPBAnCMP1
1: 8 bits \times 128 patterns mode	TPBAnCNT1 value is an odd number	(3) TPBAnCNT1/2	(5) TPBAnCMP1/2
	TPBAnCNT1 value is an even number	(4) (TPBAnCNT1 / 2) - 01 _H	

- (1) When TPBAnDPS = 0 and the TPBAnCNT1 \neq 00_H
 The applicable register is found by the formula TPBAnCNT1 - 01_H.
 (Example) When TPBAnCNT1 = 08_H: 08_H - 01_H = 07_H -> TPBA0BUF07
- (2) When TPBAnDPS = 0 and the TPBAnCNT1 = 00_H
 The applicable register is found by the TPBAnCMP1 value.
 (Example) When TPBAnCMP1 = 08_H: TPBAnBUF08
- (3) When TPBAnDPS = 1 and the TPBAnCNT1 = an odd number
 The applicable register is found by the formula TPBAnCNT1 / 2
 (Example) When TPBAnCNT1 = 07_H: 07_H / 02_H = 03_H -> TPBAnBUF03
 (lower 8 bits)
- (4) When TPBAnDPS = 1 and the TPBAnCNT1 = an even number
 The applicable register is found by the formula (TPBAnCNT1 / 2) - 01_H.
 (Example) When TPBAnCNT1 = 08_H: (08_H / 02_H) - 01_H = 03_H ->
 TPBAnBUF03 (upper 8 bits)
- (5) When TPBAnDPS = 1 and the TPBAnCNT1 = 00_H
 The applicable register is found by the formula TPBAnCMP1 / 2.
 (Example) When TPBAnCMP1 = 08_H: 08_H / 2 = 04_H -> TPBAnBUF04
 (lower 8 bits)

16.5.4 Basic Operation Example

- Overview** A PWM signal is output from the TPBnO pin according to the PWM period set in the TPBAnCMP0 register and duty cycle set in the TPBAnBUF00 to TPBAnBUF63 registers.
- Prerequisites**
- Select 16 bits × 64 patterns mode or 8 bits × 128 patterns mode by setting TPBAnDPS.
 - Set the duty cycle to TPBAnBUF00 to TPBAnBUF63.
 - Set the number of patterns to TPBAnCMP1.
- Functional description** Set the PWM period, the number of patterns, duty cycle, and level to be output. Set TPBAnTS.TPBSnTS0 = 1 (or input a synchronous start trigger) to start incrementing the timer counter value.
- The TPBnO output is set to the active level at the same time the counting begins. TPBAnCNT1 is incremented, and points to the address of the buffer in which the subsequent duty value is stored.
- The output is set to the inactive level by the match of the 16-bit counter and the TPBAnBUFm buffer register (TPBAnCB2).
- The duty value is then transferred from TPBAnBUFm to the buffer register (TPBAnCB2) by the match of the 16-bit counter and the TPBAnCMP0 buffer register (TPBAnCB0). Then, TPBAnCNT1 is incremented, and a period-matched detection interrupt (INTTPBAnIPRD) is generated. The TPBnO output is set to the active level after one count clock.
- During counting, a duty-cycle-matched detection interrupt (INTTPBAnIDTY) is generated by the match of the 16-bit counter and the buffer register (TPBAnCB2) of TPBAnBUFm.
- A number-of-patterns matched detection interrupt (INTTPBAnIPAT) is generated by the match of the 7-bit counter and the TPBAnCMP1 buffer register (TPBAnCB1).

(1) List of Operations

Table 16-20 16-Bit Counter Function

Operation		Setting Condition
16-bit counter	Start	Writing 1 to TPBAnTS or synchronous start trigger
	Clear	Compare match of TPBAnCMP0 buffer register and 16-bit counter
	Stop	Writing 1 to TPBAnTT

Table 16-21 7-Bit Counter Function

Operation		Setting Condition
7-bit counter	Start	Writing 1 to TPBAnTS or synchronous start trigger
	Clear	Compare match of TPBAnCMP1 buffer register and 7-bit counter
	Stop	Writing 1 to TPBAnTT

Table 16-22 Functions of Compare Registers

Register	Rewrite Method	Rewrite during Operation	Function
TPBAnCMP0	Reload	Possible	Setting period
TPBAnCMP1	Reload	Possible	Setting number of patterns
TPBAnBUFm	Rewrite at any time	Possible	Setting duty
TPBAnTOL	Reload	Possible	Setting output level

Table 16-23 Timer Output Function

Pin	Function
TPBnO	<ul style="list-style-type: none"> When output is enabled (TPBAnTOE = 01_H) PWM output by compare match of the TPBAnBUFm buffer register (TPBAnCB2) and the 16-bit counter When output is disabled (TPBAnTOE = 00_H) TPBAnTO set value

Table 16-24 Interrupt Requests

Interrupt	Function
INTTPBAnIPRD	Period-matched detection interrupt
INTTPBAnIDTY	Duty-cycle-matched detection interrupt
INTTPBAnIPAT	Number-of-patterns matched detection interrupt

Table 16-25 Compare Match Timing

Compare Match	Timing
TPBAnCMP0	When the 16-bit counter changes from TPBAnCMP0 to 0000 _H .
TPBAnCMP0	When the 7-bit counter changes from TPBAnCMP1 to 00 _H .
TPBAnBUFm	When the 16-bit counter matches with the buffer register (TPBAnCB2).

Table 16-26 Example of Setting Each Timer Output Condition

Pin	Item	Output Period	Output Duty	
			Output Condition	Setting Condition
TPBnO	PWM output	$(\text{TPBAnCMP0} + 1) \times$ count clock	Outputs an inactive level throughout one period (duty cycle 0%).	TPBAnBUFm = 0000 _H
			Outputs an active level of one count clock in one period.	TPBAnBUFm = 0001 _H
			Outputs an inactive level of one count clock in one period	TPBAnBUFm = TPBAnCMP0
			Outputs an active level throughout one period (duty cycle 100%).	TPBAnBUFm \geq TPBAnCMP0 + 1

When a number-of-patterns matched detection interrupt is used as a trigger of the TPBAnCMP0 and TPBAnTOL reload timing (TPBAnIRDM.TPBAnRDM0 = 0 and TPBAnTOL = 0)

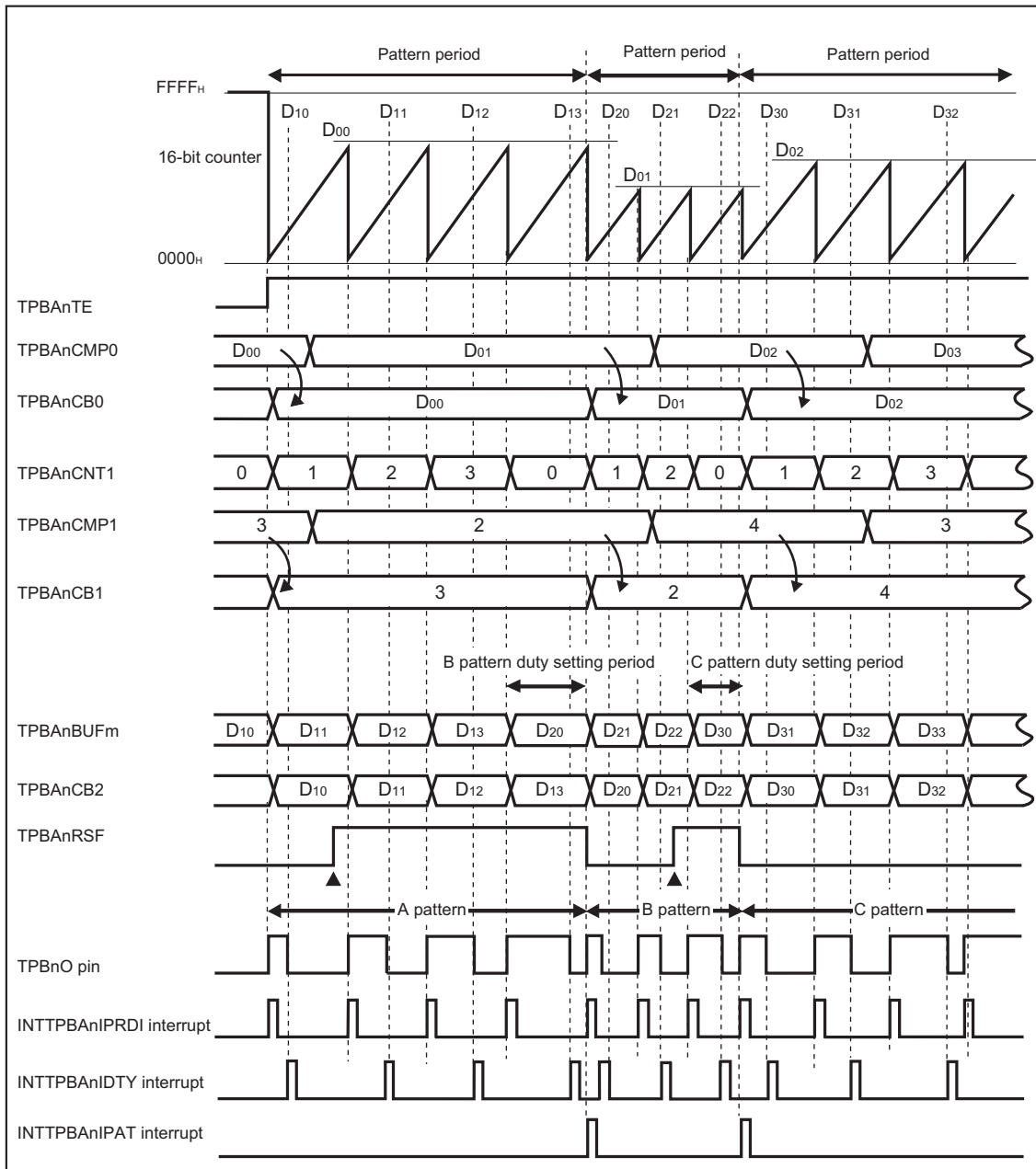

Figure 16-5 Example of Basic Timing (1/2)

Note 1. $PWM \text{ duty cycle} = \frac{TPBAnBUFm}{TPBAnCMP0 \text{ set value} + 1}$
 $PWM \text{ period} = (TPBAnCMP0 \text{ set value} + 1) \times (\text{count clock period})$

Note 2. ▲: Writing 1 to TPBAnRDT

When a period-matched detection interrupt is used as a trigger of the TPBAnCMP0 and TPBAnTOL reload timing (TPBAnIRDM.TPBAnRDM0 = 1 and TPBAnTOL = 0)

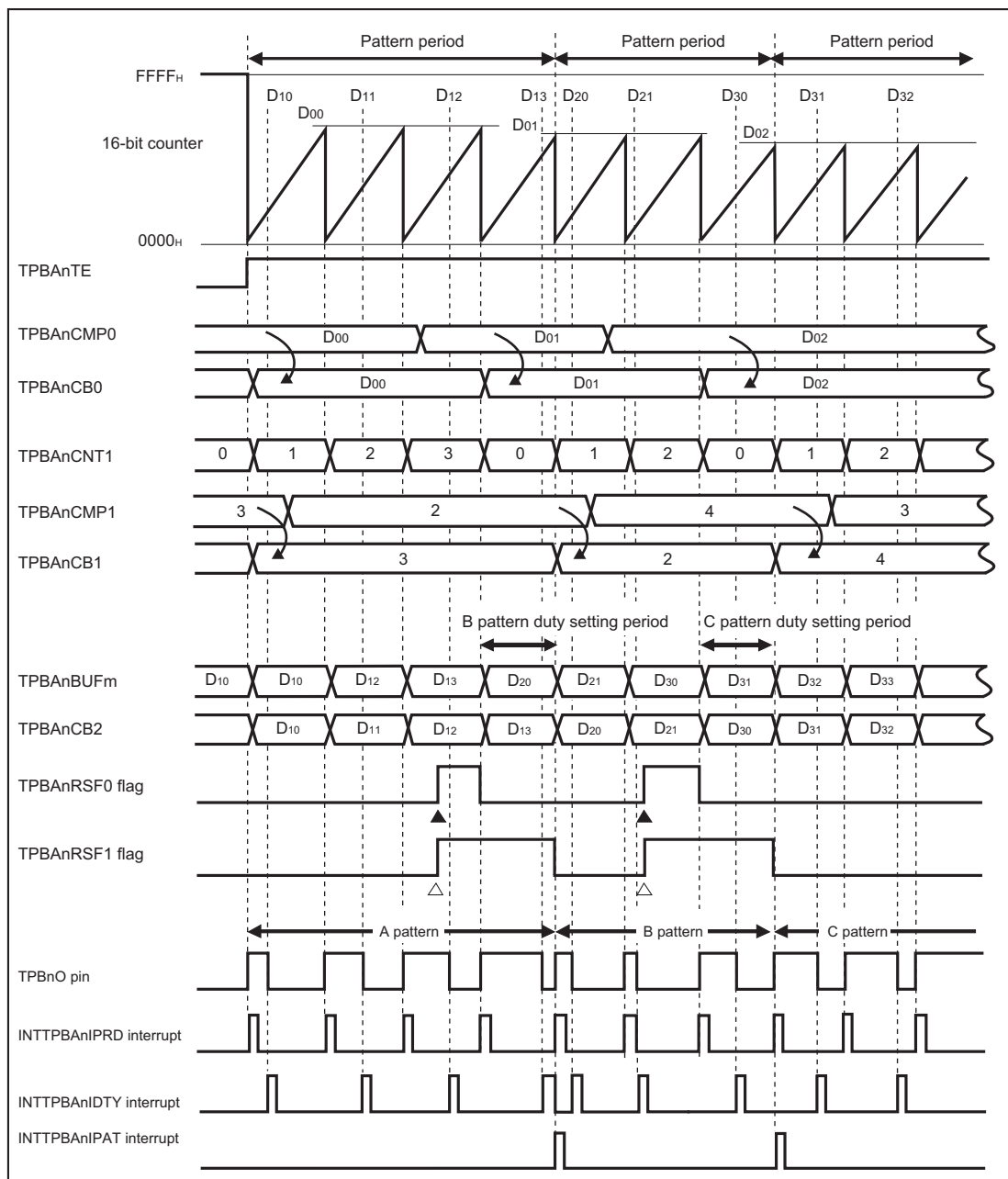

Figure 16-5 Example of Basic Timing (2/2)

- Note 1. $PWM \text{ duty cycle} = (TPBAnBUFm) / (TPBAnCMP0 \text{ set value} + 1)$
 $PWM \text{ period} = (TPBAnCMP0 \text{ set value} + 1) \times (\text{count clock period})$
- Note 2. ▲ Writing 1 to TPBAnRDT0
- Note 3. Δ: Writing 1 to TPBAnRDT1

Section 17 OS Timer (OSTM)

This section contains a generic description of the OS timer.

17.1 OSTM Features

Instances This product has the following number of instances of the OS timer.

Table 17-1 Instances of OS timer

OS Timer	
Instances	2
Name	OSTMn

Instances index n Throughout this section, the individual instances of the OS timer are identified by the index "n" (n = 0, 1), for example OSTMnTO for the OS timer n output register.

Register address All OS timer register addresses are given as address offsets from the individual base addresses <OSTMn_base0>.or <OSTMn_base1>. The <OSTMn_base> addresses of each OSTMn are listed in the following table.

Table 17-2 Register Base Addresses

OSTMn	<OSTMn_base0> Address	<OSTMn_base1> Address
OSTM0	FF80 0000 _H	FFFF C000 _H
OSTM1	FF80 1000 _H	FFFF C100 _H

Clock supply All OS timers provide one clock input.

Table 17-3 OSTM Clock Supply

OSTMn	OSTMn Clock	Connected to
OSTM0	PCLK	Clock controller
OSTM1		

Interrupts The OS timers can generate the following interrupt requests.

Table 17-4 OSTMn Interrupt Requests

OSTMn Signals	Function	Connected to
OSTM0TINT	OSTM0 interrupt	Interrupt controller INTOSTM0
OSTM1TINT	OSTM1 interrupt	Interrupt controller INTOSTM1

I/O signals The I/O signals of the OS timers are listed in the following table.

Table 17-5 OSTMn I/O Signals

OSTNn Signals	Function	Connected to
OSTM0TTOUT	OS timer output	OSTM0O
OSTM1TTOUT		OSTM1O

Table 17-6 OSTMn Signal Processing

OSTNn Signals	Function	Connected to
OSTMnTCKE	Enabling the counter clock	The clock signal selected by the setting of the IC0CKSELn register
OSTMnTSST	Synchronous counting start trigger	PIC function

Note 1. The counter clock supplied as the OSTMnTCKE signal depends on the settings for TAUB and TAUJ in the IC0CKSELn register. For details, refer to Section 17.3.1, Clock Signal to Drive Counting.

Note 2. If you wish to use the synchronous counting start trigger (OSTMnTSST), refer to Section 24.4.1, Simultaneous Start Trigger Function.

17.2 Functional Overview

- Features summary** The OS timer has the following features.
- Two operating modes
 - Interval timer mode
 - Free-running comparison mode
 - Two output modes
 - Software control mode
 - Timer-output toggling mode
 - Synchronized starting of the timers is possible

The following block diagram shows the main components of the OS timer.

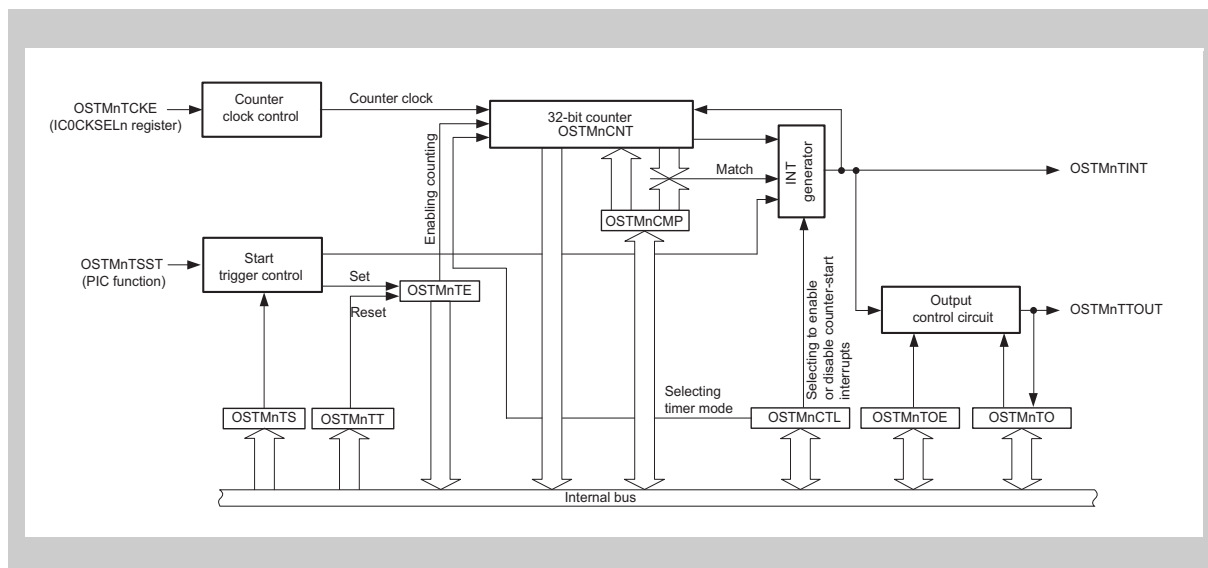

Figure 17-1 Block Diagram of the OS Timer

17.3 Functional Description

Each OS timer is a 32-bit timer/counter. The settings for operating mode specify the direction of counting (up or down) and the generation of interrupt requests.

17.3.1 Clock Signal to Drive Counting

The clock for counting by the OS timer is defined by the level of the OSTMnTCKE input signal.

- The OSTMnTCKE signal becoming 1 (at the high level) while IC0KSELn.IC0TMEN0 = 0 selects counting of cycles of PCLK.
- If IC0KSELn.IC0TMEN0 is set to 1, counting of cycles of the selected clock signal from TAUB or TAUJ is selected.

This is illustrated in the following figures.

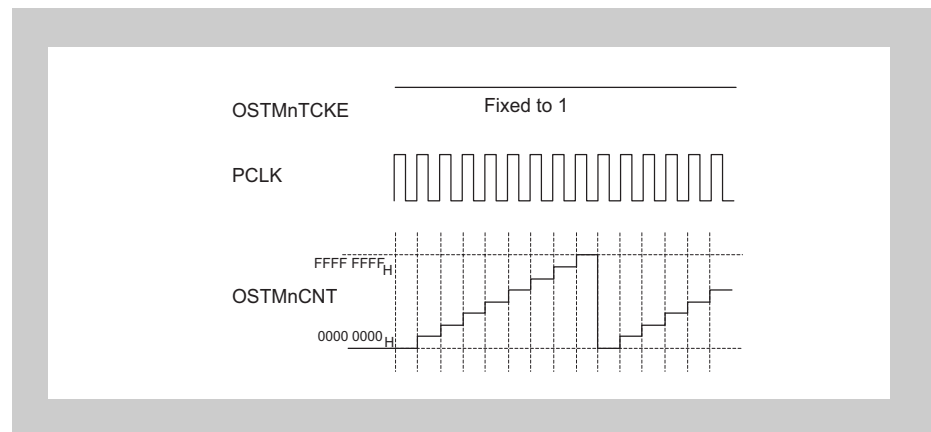

Figure 17-2 Counter Operation with the High Level on OSTMnTCKE (IC0KSELn.IC0TMEN0 = 0)

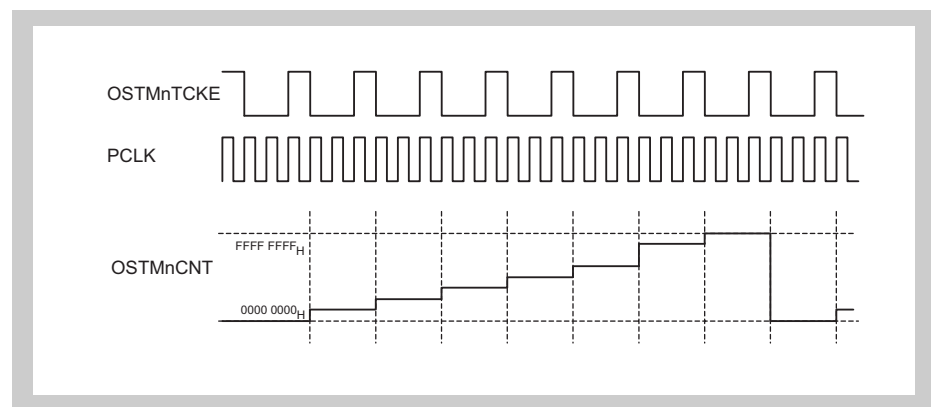

Figure 17-3 Counter Operation with OSTMnTCKE Set to the High Level in Every 3rd Cycle of PCLK (IC0KSELn.IC0TMEN0 = 1)

Each OSTM is capable of intermittent operation with an external signal (OSTMnTCKE) disabling and enabling the clock for counting.

The counter-clock-enable signal can be selected by the IC0CKSELn register from among 20 timer-output channels: 16 from TAUB0 and 4 from TAUJ0.

- Caution 1. Select a counter-clock-enable signal for OSTMn while the operation of OSTMn is stopped (the OSTMnTE.OSTMnTE bit is 0).
- Caution 2. After using the IC0CKSELn.IC0CKSELn[13:0] bits to select the counter-clock-enable signal for OSTMn, set the IC0CKSELn.IC0TMENn bit to 1.
- Caution 3. If TAUBn or TAUJn is selected as the source of a counter-clock-enable signal for OSTMn (the IC0CKSELn.IC0TMENn bit is 1), do not change the operation of TAUBn or TAUJn while the OSTMn is operating (the OSTMnTE.OSTMnTE bit is 1).

[Setting procedure]

- (1) Confirm that the OSTMnTE.OSTMnTE bit is 0 (OSTMn operation is stopped).
 - (2) Set the IC0CKSELn.IC0CKSELn[13:0] bits to select a counter-clock-enable signal for the OSTMn.
 - (3) Set the IC0CKSELn.IC0TMENn bit to 1.
 - (4) Enable OSTMn operation by setting the OSTMnTS.OSTMnTS bit to 1.
-

17.3.2 Output Modes

The OS timer has the following output modes. The mode is selected by the setting of the OSTMnTOE.OSTMnTOE bit.

- Software control mode (the OSTMnTOE.OSTMnTOE bit is 0)

The level on the OSTMnTTOUT signal corresponds to the setting of the OSTMnTO.OSTMnTO bit.

- Timer-output toggling mode (the OSTMnTOE.OSTMnTOE bit is 1)

The OSTMnTTOUT output is toggled each time an OSTMnTINT request is generated.

Both output modes are illustrated in the following figure.

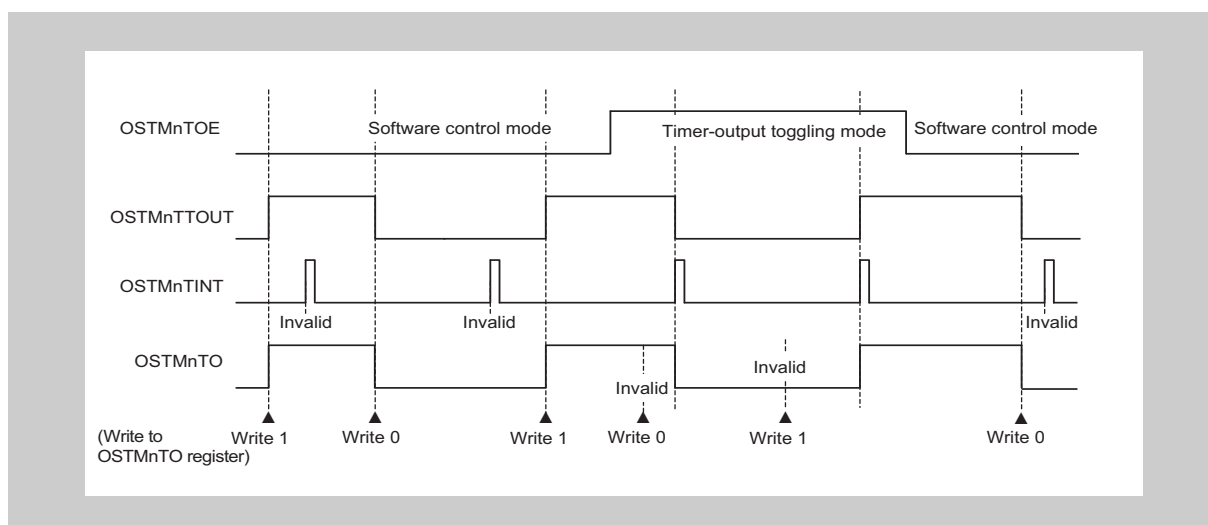

Figure 17-4 Timing Diagram of Output Modes

The above timing diagram shows the following operations.

- In software control mode, the level of the OSTMnTTOUT output changes in accord with the value set in the OSTMnTO.OSTMnTO bit.
- In timer-output toggling mode, the value of the OSTMnTO.OSTMnTO bit and level of the OSTMnTTOUT output are toggled each time an OSTMnTINT interrupt request is generated.

17.3.3 Interrupt Request Generation

An OSTMnTINT interrupt request is generated whenever the counter reaches 0000 0000_H (in interval timer mode) or matches the comparison value (in free-running comparison mode).

An interrupt request can also be generated on starting and restarting of the counter. This is controlled by the OSTMnCTL.OSTMnMD0 bit.

Since OSTMnTINT triggers toggling of the OSTMnTTOUT output in timer-output toggling mode (OSTMnTOE.OSTMnTOE is 1), the setting of the OSTMnCTL.OSTMnMD0 bit also affects the output (OSTMnTTOUT).

This is illustrated in the following figure.

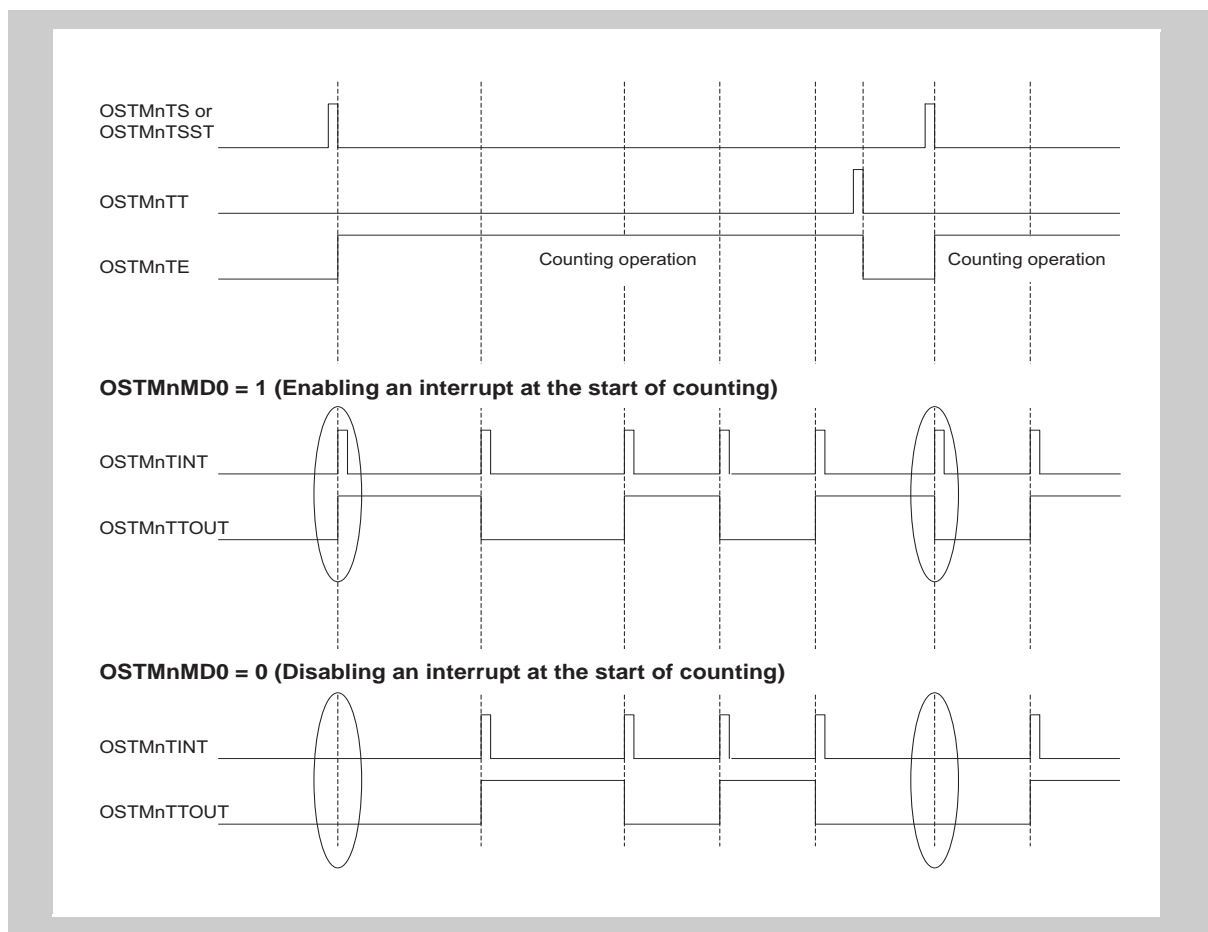

Figure 17-5 Generating an Interrupt When Counting Starts

17.3.4 Starting and Stopping the Timer

The OS timer is started and stopped as follows.

Starting the timer

The timer is started in either of the following ways:

- setting the OSTMnTS.OSTMnTS bit to 1 or
- placing the high level on the OSTMnTSST signal (when starting synchronous counting).

Status bit OSTMnTE.OSTMnTE is set to 1.

The counter starts to count up or down in accord with the settings for operating mode. For details, refer to Section 17.3.5, Interval Timer Mode and Section 17.3.6, Free-Running Comparison Mode.

Stopping the timer

Setting the OSTMnTT.OSTMnTT bit to 1 stops the timer.

This also clears the OSTMnTE.OSTMnTE status flag.

When the counter is stopped, values in the OSTMnTO and OSTMnCNT registers and the level of the OSTMnTTOUT output are retained until further counting operations start.

Synchronous start

The OSTMnTSST signal output from the PIC module can be used to start multiple timers at the same time.

Refer to Section 24, Peripheral Interconnection (PIC).

Initialization

To initialize interval timer mode and free-running comparison mode after reset release, take the following steps.

1. Set the value where the down-counter is to start counting or the value for comparison in the OSTMnCMP register.
2. In case of output (OSTMnTTOUT) toggling:
 - initialize the OSTMnTO register during operation in software control mode (OSTMnTOE.OSTMnTOE = 0) and
 - select timer-output toggling (OSTMnTOE.OSTMnTOE = 1).
3. Set the OSTMnCTL.OSTMnMD1 bit to select interval timer mode or free-running comparison mode.
4. Select the interrupt mode for the start of counting (OSTMnCTL.OSTMnMD0 = 1 or 0).

17.3.5 Interval Timer Mode

Select the interval timer mode when an OS timer is to be used as a reference timer for generating interrupt requests at a fixed interval.

(1) Basic Operation in Interval Timer Mode

In interval timer mode, the timer counts down from the value specified in the OSTMnCMP register. An OSTMnTINT interrupt request is generated when the counter underflows (reaches 0000 0000_H).

Select interval timer mode by setting OSTMnCTL.OSTMnMD1 = 0.

New values can be written to the OSTMnCMP register at any time. If it is rewritten during count operation, the counter loads the new OSTMnCMP value when the next 0000 0000_H is reached. Then the counter continues with the new value.

Periods of OSTMnTINT and OSTMnTTOUT output

The periods of OSTMnTINT and OSTMnTTOUT output are as follows.

- OSTMnTINT generation period = counter-clock period × (OSTMnCMP + 1)
- OSTMnTTOUT output period = OSTMnTINT generation period × 2

The following figure shows the basic operation of the OS timer in interval timer mode with counter-start interrupts enabled (OSTMnCTL.OSTMnMD0 = 1) and OSTMnTTOUT output in timer-output toggling mode (OSTMnTOE.OSTMnTOE = 1).

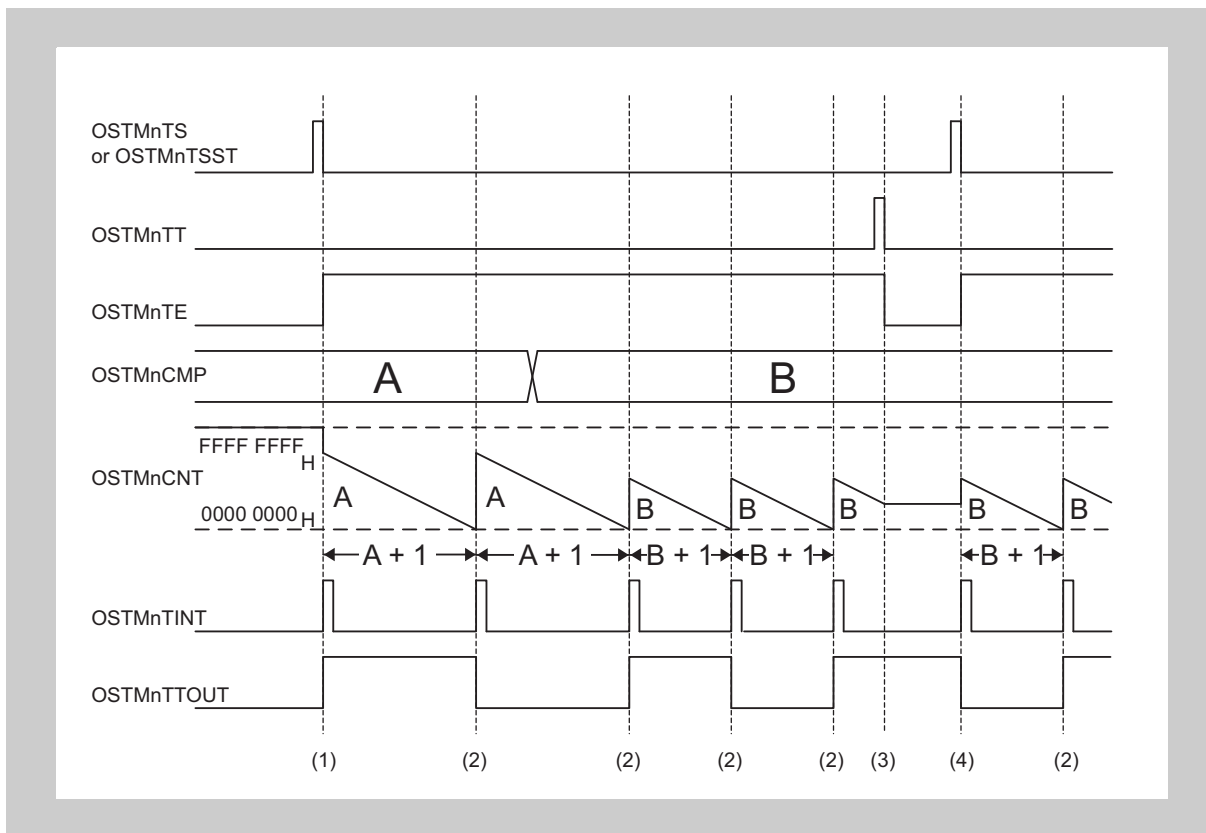

Figure 17-6 Timing Diagram of OS Timer in Interval Timer Mode

The above timing diagram shows the following operations.

1. The counter starts counting when $OSTMnTS.OSTMnTS = 1$ or $OSTMnTSST$ is high (if a synchronous start trigger is in use). The counter starts counting-down from the value of $OSTMnCMP$.
If $OSTMnCTL.OSTMnMD0$ is 1, $OSTMnTINT$ interrupt requests are generated at the start of counting and the $OSTMnTTOUT$ output is toggled. The $OSTMnCNT$ register contains the current value as the counter.
2. When the counter reaches $0000\ 0000_H$, an $OSTMnTINT$ interrupt request is generated and the $OSTMnTTOUT$ output is toggled. The counter loads the new initial value from $OSTMnCMP$ and continues counting down.
3. When the counter is stopped ($OSTMnTT.OSTMnTT = 1$), the $OSTMnTE.OSTMnTE$ bit is cleared to indicate disabling of the counter. The counter retains its current value until it is restarted.
4. When counting is restarted ($OSTMnTS.OSTMnTS = 1$, or $OSTMnTSST$ is high if the synchronous start trigger is in use), the counter loads the new initial value from $OSTMnCMP$ and continues counting down.

Forced restart The counter is forcibly restarted by setting `OSTMnTS.OSTMnTS = 1` or by setting the `OSTMnTSST` signal at the high level (if the synchronous start trigger is in use) during counting.

The counter loads the initial value from the `OSTMnCMP` register and continues counting down.

The following figure shows a forced restart of the OS timer in interval timer mode, with counter-start interrupts enabled (`OSTMnCTL.OSTMnMD0 = 1`) and `OSTMnTTOUT` output in timer-output toggling mode (`OSTMnTOE.OSTMnTOE = 1`).

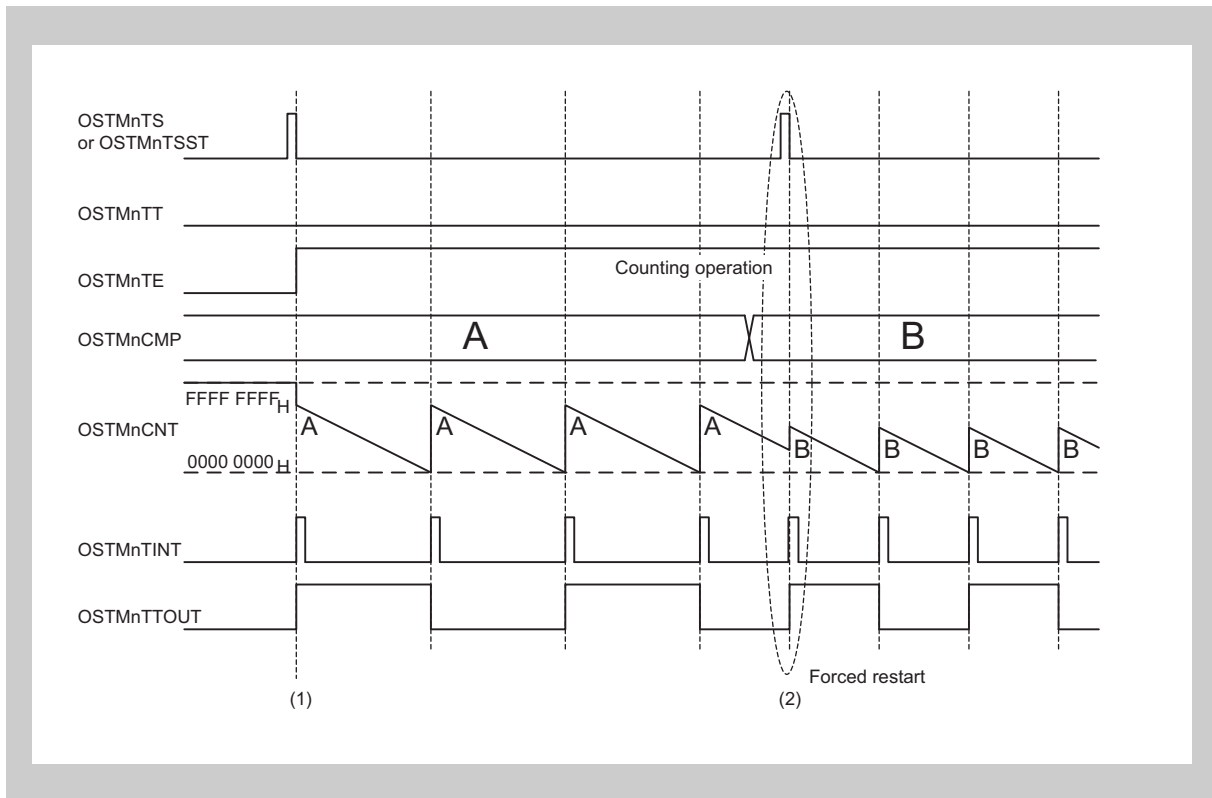

Figure 17-7 Timing Diagram for a Forced Restart in Interval Timer Mode

Operations shown in the above timing diagram are as follows.

1. The counter is started and stopped as shown in and described under Figure 17-6, Timing Diagram of OS Timer in Interval Timer Mode.
2. Writing `OSTMnTS.OSTMnTS = 1` or placing the high level on `OSTMnTSST` (if the synchronous start trigger is in use) forcibly restarts the counter while counting is in progress (i.e. while `OSTMnTE.OSTMnTE = 1`). The counter immediately loads the start value from the `OSTMnCMP` register and continues counting down. When `OSTMnCTL.OSTMnMD0 = 1`, an `OSTMnTINT` interrupt request is generated and the `OSTMnTTOUT` output is toggled.

(2) Operation when OSTMnCMP = 0000 0000_H

When OSTMnCMP = 0000 0000_H, the OS timer behaves as follows.

- When PCLK is selected as the counter clock, the OSTMnTINT interrupt request signal stays fixed to the high level from the start of counting to the end of counting. Accordingly, output of the OSTMnTINT interrupt is not possible when OSTMnCMP = 0000 0000_H. However, the timer output (OSTMnTTOUT) is available in this situation. When the timer output (OSTMnTTOUT) is in timer-output toggling mode, the output is toggled every time a cycle of the clock is counted.

The following figure shows operations of the OS timer when OSTMnCMP = 0000 0000_H, counter-start interrupts are enabled (OSTMnCTL.OSTMnMD0 = 1), and output on OSTMnTTOUT is in timer-output toggling mode (OSTMnTOE.OSTMnTOE = 1).

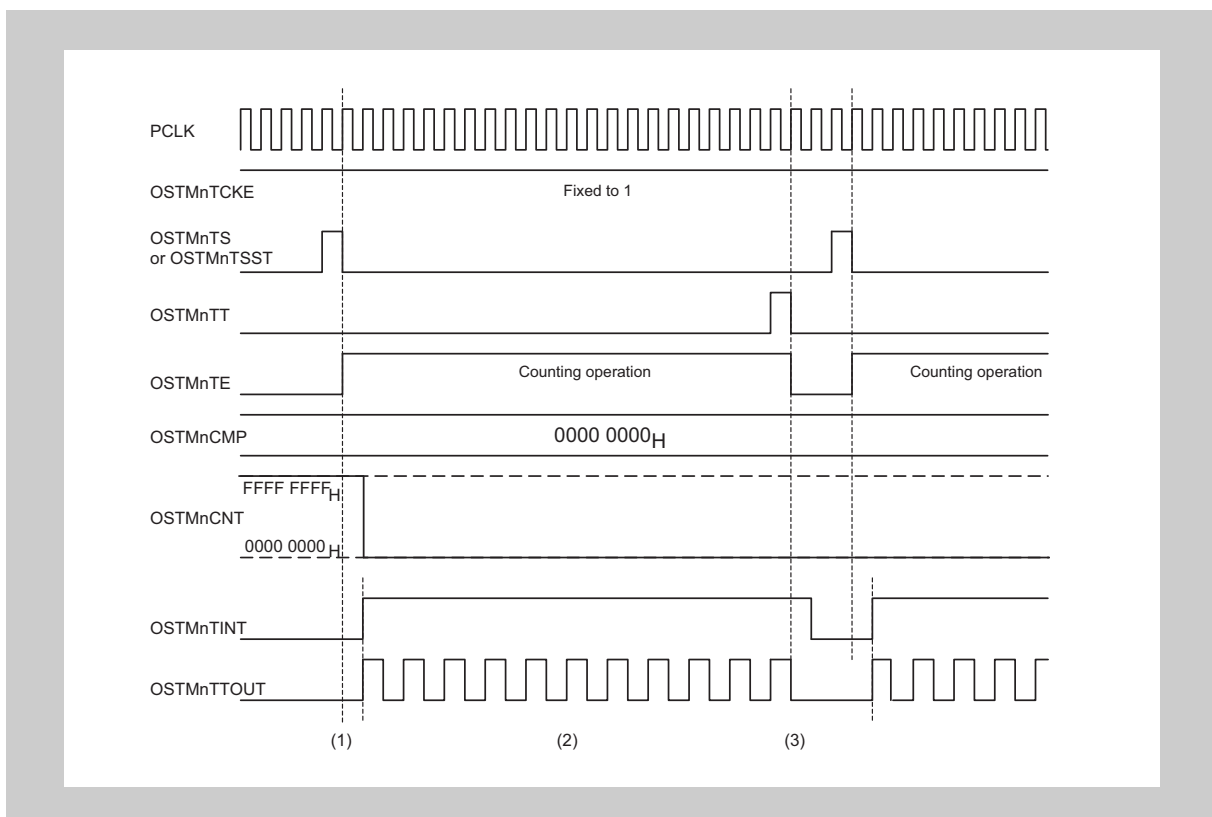

Figure 17-8 Timing Diagram for Operations When OSTMnCMP = 0000 0000_H in Interval Timer Mode (PCLK Is Selected as the Counter Clock, i.e. OSTMnTCKE Is High)

The timing diagram above shows the following.

- The counter is reloaded with the value in OSTMnCMP as soon as it starts counting, so the value 0000 0000_H is retained in OSTMnCMP.
- Toggling of the OSTMnTTOUT output starts on generation of the OSTMnTINT interrupt request (OSTMnTINT is fixed to the high level because PCLK is selected as the counter clock in the figure).
- After the counter stops, the OSTMnTINT interrupt request signal is deasserted and the level of the OSTMnTTOUT output is retained.

17.3.6 Free-Running Comparison Mode

(1) Basic Operation in Free-Running Comparison Mode

In free-running comparison mode, the counter counts up from 0000 0000_H to FFFF FFFF_H. An OSTMnTINT interrupt request is output when the current value of the counter matches the value of the OSTMnCMP register. The free-running comparison mode is selected by setting the OSTMnCTL.OSTMnMD1 bit to 1.

New values can be written to the OSTMnCMP register at any time.

The following figure shows the basic operation of the OS timer in free-running comparison mode with the start of counting enabled (OSTMnTS.OSTMnTS = 1) and OSTMnTTOUT output in timer-output toggling mode (OSTMnTOE.OSTMnTOE = 1).

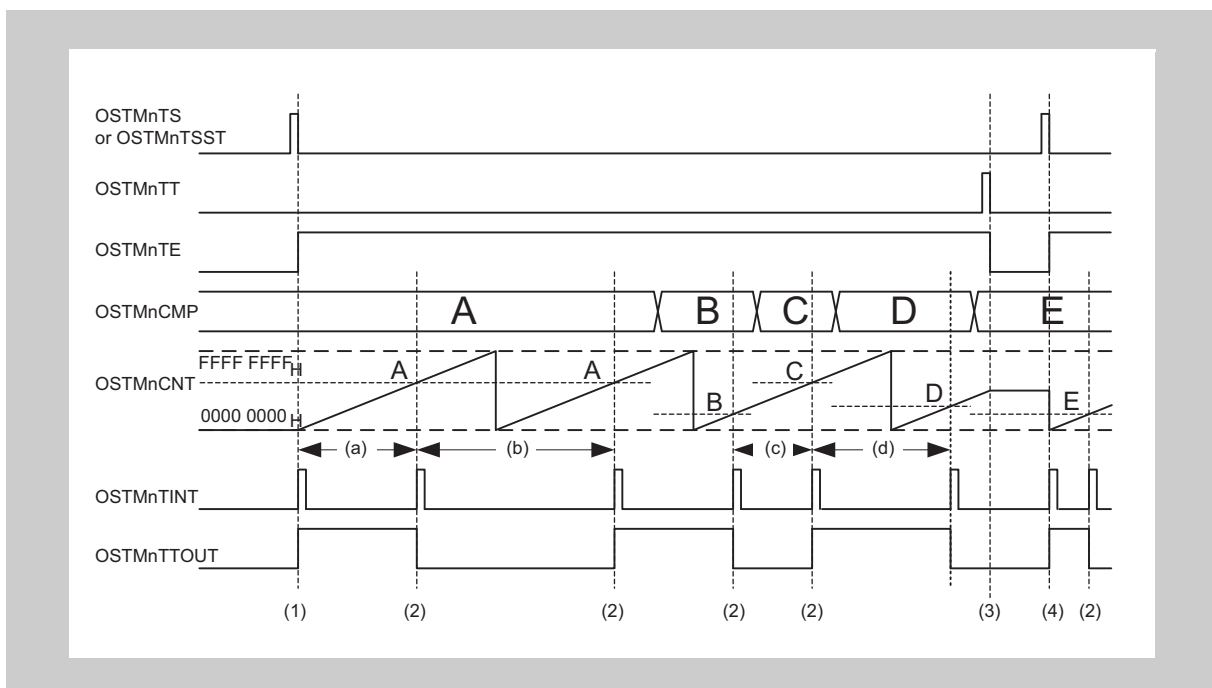

Figure 17-9 Timing Diagram of OS Timer in Free-Running Comparison Mode

The timing diagram above shows the following.

1. The counter starts counting when OSTMnTS.OSTMnTS = 1, or when OSTMnTSST is high if the synchronous start trigger is in use. The OSTMnTE.OSTMnTE bit is set to indicate enabling of the counter. The counter counts up from 0000 0000_H to FFFF FFFF_H. The OSTMnCNT register is the counter, so it contains the current value.
2. When the current counter value matches the value in the OSTMnCMP register, an OSTMnTINT interrupt request is generated and the OSTMnTTOUT output is toggled.
3. When the counter is stopped (OSTMnTT.OSTMnTT = 1), the OSTMnTE.OSTMnTE bit is cleared to indicate disabling of the counter. The counter retains its current value until it is restarted.
4. Counting by the counter restarts from 0000 0000_H when OSTMnTS.OSTMnTS = 1, or when OSTMnTSST is high if the synchronous start trigger is in use.

The OSTMnTINT interrupt-generation period depends on the timing for updating of the OSTMnCMP register and the counter value at the time. For the formula to calculate the period for generation of the OSTMnTINT interrupt, refer to the table below.

Table 17-7 OSTMnTINT Generation Timing

Old Value for Comparison	New Value for Comparison	Counter Value at the Time of Rewriting	Period of OSTMnTINT Generation	Label in Timing Diagram
Counter starts			$(A + 1) \times \text{counter clock period}$	(a)
A	A	No rewriting	$(\text{FFFF FFFF}_H + 1) \times \text{counter clock period}$	(b)
B	$C > B$	$B < \text{counter value} < C$	$(C - B) \times \text{counter clock period}$	(c)
C	$D < C$	Counter value $> D, C$	$(\text{FFFF FFFF}_H - C + D + 1) \times \text{counter clock period}$	(d)

Note A, B, C and D indicate the values of OSTMnCMP over the intervals thus labeled in Figure 17-9, Timing Diagram of OS Timer in Free-Running Comparison Mode.

Forced restart Forced restarting does not proceed during counting even if the OSTMnTS.OSTMnTS bit is set, or if OSTMnTSST is high when the synchronous start trigger is in use.

The counter ignores the attempted setting and continues counting.

(2) Operation when OSTMnCMP = 0000 0000_H

The following figure shows the operation of the OS timer when OSTMnCMP = 0000 0000_H, counter-start interrupts are enabled (OSTMnCTL.OSTMnMD0 = 1), and OSTMnTTOUT is in timer-output toggling mode (OSTMnTOE.OSTMnTOE = 1).

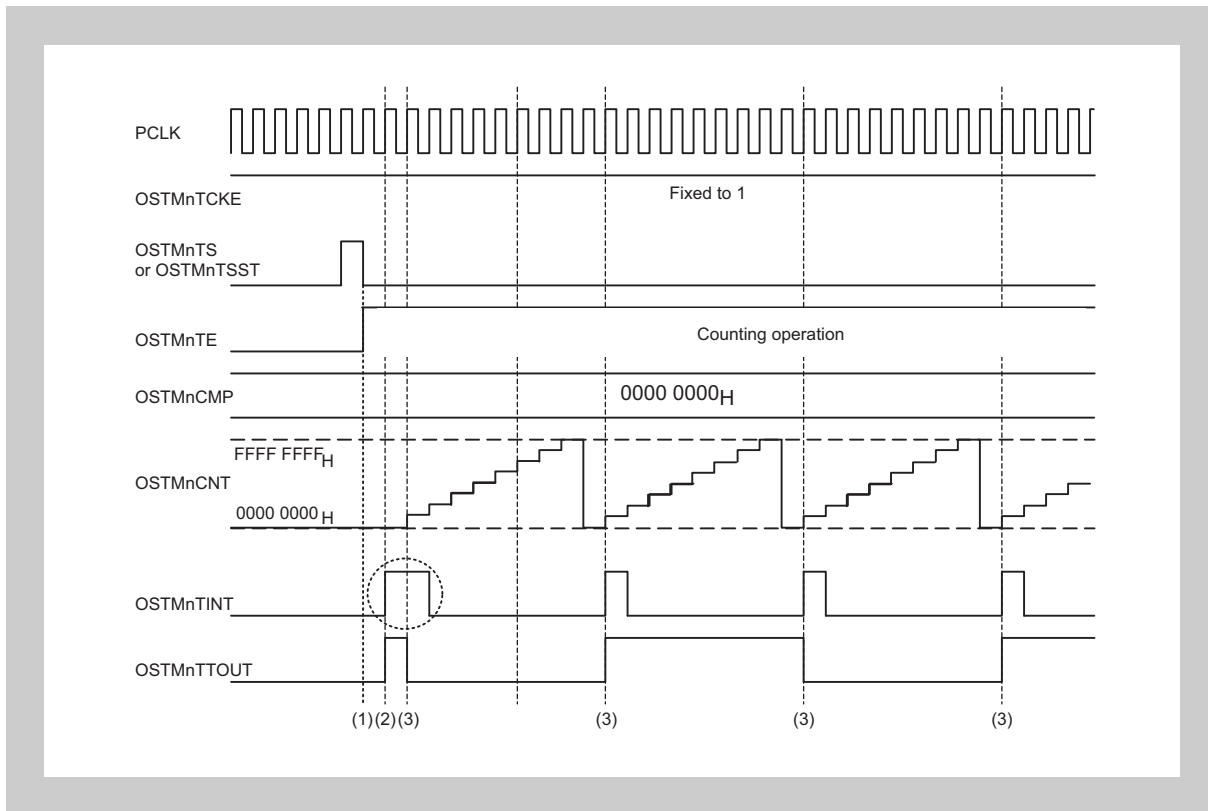

Figure 17-10 Timing Diagram when OSTMnCMP = 0000 0000_H in Free-Running Comparison Mode with PCLK Selected as the Counter Clock (OSTMnTCKE Is High)

The above timing diagram shows the following operations.

1. Once the counter starts, it counts up from 0000 0000_H to FFFF FFFF_H.
2. An OSTMnTINT interrupt request is generated when counting starts (and the OSTMnTTOUT output is toggled).
3. The OSTMnTTOUT output is toggled. A comparison interrupt is only generated if the current value of the counter matches that in the OSTMnCMP register.

Note When PCLK is selected as the counter clock (OSTMnTCKE is high) and the value for comparison is 0 (OSTMnCMP = 0000 0000_H), OSTMnTINT initially stays at the high level over two cycles of PCLK, and one interrupt request is generated for every rising edge of OSTMnTINT.

17.4 Registers

This section describes all registers of the OS timer.

17.4.1 OS Timer Registers Overview

The OS timer is controlled and operated by the following registers.

Table 17-8 List of OS Timer Registers

Register Name	Symbol	Address
OSTM compare register	OSTMnCMP	<OSTMn_base1>
OSTM counter register	OSTMnCNT	<OSTMn_base1> + 4 _H
OSTM output register	OSTMnTO	<OSTMn_base1> + 8 _H
OSTM output enable register	OSTMnTOE	<OSTMn_base1> + C _H
OSTM count enable status register	OSTMnTE	<OSTMn_base1> + 10 _H
OSTM count start trigger register	OSTMnTS	<OSTMn_base1> + 14 _H
OSTM count stop trigger register	OSTMnTT	<OSTMn_base1> + 18 _H
OSTM control register	OSTMnCTL	<OSTMn_base0> + 20 _H
OSTM input clock select function register 0	IC0CKSEL0	FF83F000 _H
OSTM input clock select function register 1	IC0CKSEL1	FF83F004 _H

17.4.2 OS Timer Registers in Detail

(1) OSTMnCMP - OSTM Compare Register

Depending on the mode of operation, this register holds the start value for the down-counter or the value for comparison with that of the counter.

Access This register is readable/writable in 32-bit units.

Address <OSTMn_base1>

Initial value 0000 0000_H

This register is initialized by a reset from any source.

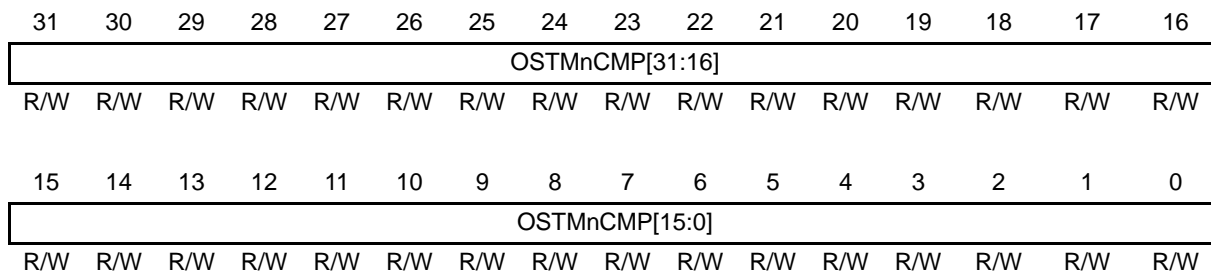

Table 17-9 OSTMnCMP Register Contents

Bit Position	Bit Name	Function
31 to 0	OSTMnCMP [31:0]	<ul style="list-style-type: none"> In interval timer mode: start value of the down-counter In free-running comparison mode: value for comparison

(2) OSTMnCNT - OSTM Counter Register

This register indicates the counter value of the timer.

Access This register is readable in 32-bit units.

Address <OSTMn_base1> + 4_H

Initial value The initial value depends on the operating mode of the OS timer. Refer to Table 17-11, Correspondence between Operating Mode, Counting Direction and Initial Value. This register is initialized by a reset from any source.

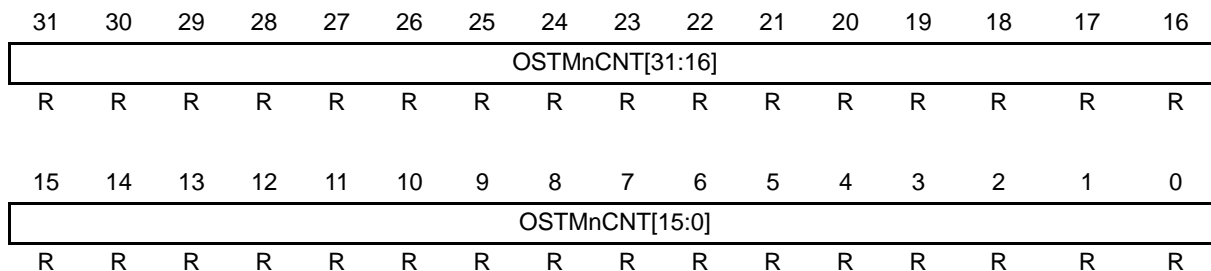

Table 17-10 OSTMnCNT Register Contents

Bit Position	Bit Name	Function
31 to 0	OSTMnCNT[31:0]	32-bit counter value

The following table shows the correspondence between operating mode, counting direction and initial value. The initial value is the value read from the counter after a change to the operating mode.

Table 17-11 Correspondence between Operating Mode, Counting Direction and Initial Value

Timer Operating Mode	OSTMnCTL.OSTMnMD1	Counting Direction	Initial value
Interval timer mode	0*	Down	FFFF FFFF _H
Free-running comparison mode	1	Up	0000 0000 _H

Note: * Value after reset

(3) OSTMnTO - OSTM Output Register

This register is for specifying or reading of the level of the OSTMnTTOUT output signal.

Access This register is readable and writable in 8-bit units. Writing can only proceed when the software control mode is selected (OSTMnTOE.OSTMnTOE = 0).

Address <OSTMn_base1> + 8_H

Initial value 00_H

This register is initialized by a reset from any source.

7	6	5	4	3	2	1	0
0	0	0	0	0	0	0	OSTMnTO
R	R	R	R	R	R	R	R/W

Table 17-12 OSTMnTO Register Contents

Bit Position	Bit Name	Function
0	OSTMnTO	For specifying or reading the level of the OSTMnTTOUT output signal 0: Low level 1: High level

(4) OSTMnTOE - OSTM Output Enable Register

This register specifies OSTMnTTOUT output mode.

Access This register is readable/writable in 8-bit units.

Address <OSTMn_base1> + C_H

Initial value 00_H

This register is initialized by a reset from any source.

7	6	5	4	3	2	1	0
0	0	0	0	0	0	0	OSTMnTOE
R	R	R	R	R	R	R	R/W

Table 17-13 OSTMnTOE Register Contents

Bit Position	Bit Name	Function
0	OSTMnTOE	This bit specifies the OSTMnTTOUT output mode. 0: Software control mode: The level corresponding to the setting of OSTMnTO.OSTMnTO is output to OSTMnTTOUT. 1: Timer-output toggling mode: OSTMnTTOUT output is toggled whenever an OSTMnTINT interrupt request is generated.

(5) OSTMnTE - OSTM Count Enable Status Register

This register indicates whether the counter is enabled or disabled.

Access This register is readable in 8-bit units.

Address <OSTMn_base1> + 10_H

Initial value 00_H

This register is initialized by a reset from any source.

7	6	5	4	3	2	1	0
0	0	0	0	0	0	0	OSTMnTE
R	R	R	R	R	R	R	R

Table 17-14 OSTMnTE Register Contents

Bit Position	Bit Name	Function
0	OSTMnTE	This bit indicates whether the counter is enabled or disabled. 0: Counter disabled 1: Counter enabled This bit is set to 1 in response to OSTMnTS.OSTMnTS being set to 1, or OSTMnTSST being at the high level if synchronous starting is in use. Setting OSTMnTT.OSTMnTT to 1 re-sets this bit to 0.

Note When OSTMnTE = 0, the counter retains its value.

If the counter is restarted, it

- restarts counting down from the value in the OSTMnCMP register if it is in interval timer mode or
- restarts counting up from the counter value 0000 0000_H if it is in free-running comparison mode.

(6) OSTMnTS - OSTM Count Start Trigger Register

This register starts the counter.

Access This register is writable in 8-bit units. It is always read as 00_H.

Address <OSTMn_base1> + 14_H

Initial value 00_H

This register is initialized by a reset from any source.

7	6	5	4	3	2	1	0
0	0	0	0	0	0	0	OSTMnTS
R	R	R	R	R	R	R	W

Table 17-15 OSTMnTS Register Contents

Bit Position	Bit Name	Function
0	OSTMnTS	This bit starts the counter. 0: No function 1: Starts the counter and sets OSTMnTE.OSTMnTE = 1. <ul style="list-style-type: none"> In interval timer mode, a forced restart is executed if this bit is set while OSTMnTE.OSTMnTE = 1. In free-running comparison mode, setting this bit is ignored as long as OSTMnTE.OSTMnTE = 1.

(7) OSTMnTT - OSTM Count Stop Trigger Register

This register stops the counter.

Access This register is writable in 8-bit units. It is always read as 00_H.

Address <OSTMn_base1> + 18_H

Initial value 00_H

This register is initialized by a reset from any source.

7	6	5	4	3	2	1	0
0	0	0	0	0	0	0	OSTMnTT
R	R	R	R	R	R	R	W

Table 17-16 OSTMnTT Register Contents

Bit Position	Bit Name	Function
0	OSTMnTT	Stops the counter. 0: No function 1: Stops the counter and clears the OSTMnTE.OSTMnTE bit. When the counter has stopped, this bit returns to 0.

(8) OSTMnCTL - OSTM Control Register

This register specifies the operating mode for the counter and controls the generation of OSTMnTINT interrupt requests when counting starts.

Access This register is readable/writable in 8-bit units. Writing to this register is only possible if the counter is disabled (OSTMnTE.OSTMnTE = 0).

Address <OSTMn_base0> + 20_H

Initial value 00_H

This register is initialized by a reset from any source.

7	6	5	4	3	2	1	0
0	0	0	0	0	0	OSTMn MD1	OSTMn MD0
R	R	R	R	R	R	R/W	R/W

Table 17-17 OSTMnCTL Register Contents

Bit Position	Bit Name	Function
1	OSTMnMD1	Specifies the operating mode for the counter. 0: Interval timer mode 1: Free-running comparison mode
0	OSTMnMD0	Controls the generation of OSTMnTINT interrupt requests at the start of counting. 0: Interrupts when counting starts are disabled. 1: Interrupts when counting starts are enabled.

(9) IC0CKSEL0 - OSTM Input Clock Select Function Register 0

This register is used to select the clock-enable signal for the counter clock of OSTM0.

Access This register is readable/writable in 16-bit units.

Address FF83F000_H

Initial value 0000_H

This register is initialized by a reset from any source.

15	14	13	12	11	10	9	8	7	6	5	4	3	2	1	0
IC0TME NO	0	IC0TMS EL01	IC0TMS EL00	0	0	IC0CKS EL021	IC0CKS EL020	0	0	0	0	IC0CKS EL003	IC0CKS EL002	IC0CKS EL001	IC0CKS EL000
R/W	R	R/W	R/W	R	R	R/W	R/W	R	R	R	R	R/W	R/W	R/W	R/W

Table 17-18 IC0CKSEL0 Register Contents

Bit Position	Bit Name	Function																														
15	IC0TMEN0	Selects output of the counter-clock-enable signal. <table border="1"> <thead> <tr> <th>IC0TMEN0</th><th>Description</th></tr> </thead> <tbody> <tr> <td>0</td><td>Input the high level as the counter-clock-enable signal for the OSTM0 (PCLK is selected as the counter clock).</td></tr> <tr> <td>1</td><td>Input the counter-clock-enable signal selected by IC0TMSEL00 and IC0TMSEL01 to OSTM0.</td></tr> </tbody> </table>	IC0TMEN0	Description	0	Input the high level as the counter-clock-enable signal for the OSTM0 (PCLK is selected as the counter clock).	1	Input the counter-clock-enable signal selected by IC0TMSEL00 and IC0TMSEL01 to OSTM0.																								
IC0TMEN0	Description																															
0	Input the high level as the counter-clock-enable signal for the OSTM0 (PCLK is selected as the counter clock).																															
1	Input the counter-clock-enable signal selected by IC0TMSEL00 and IC0TMSEL01 to OSTM0.																															
13,12	IC0TMSEL00, IC0TMSEL01	According to the setting, these bits select the timer signal indicated below as the counter-clock-enable signal (from among the counter-clock-enable signals selected by bits 11 to 0). <table border="1"> <thead> <tr> <th>IC0TMSEL01</th><th>IC0TMSEL00</th><th>Description</th></tr> </thead> <tbody> <tr> <td>0</td><td>0</td><td>TAUB0</td></tr> <tr> <td>0</td><td>1</td><td>Setting prohibited</td></tr> <tr> <td>1</td><td>0</td><td>TAUJ0</td></tr> <tr> <td>1</td><td>1</td><td>Setting prohibited</td></tr> </tbody> </table>	IC0TMSEL01	IC0TMSEL00	Description	0	0	TAUB0	0	1	Setting prohibited	1	0	TAUJ0	1	1	Setting prohibited															
IC0TMSEL01	IC0TMSEL00	Description																														
0	0	TAUB0																														
0	1	Setting prohibited																														
1	0	TAUJ0																														
1	1	Setting prohibited																														
9,8	IC0CKSEL020, IC0CKSEL021	Select a counter-clock-enable signal for input to OSTM0. <table border="1"> <thead> <tr> <th>IC0CKSEL021</th><th>IC0CKSEL020</th><th>Description</th></tr> </thead> <tbody> <tr> <td>0</td><td>0</td><td>TAUJ0 timer channel 0</td></tr> <tr> <td>0</td><td>1</td><td>TAUJ0 timer channel 1</td></tr> <tr> <td>1</td><td>0</td><td>TAUJ0 timer channel 2</td></tr> <tr> <td>1</td><td>1</td><td>TAUJ0 timer channel 3</td></tr> </tbody> </table>	IC0CKSEL021	IC0CKSEL020	Description	0	0	TAUJ0 timer channel 0	0	1	TAUJ0 timer channel 1	1	0	TAUJ0 timer channel 2	1	1	TAUJ0 timer channel 3															
IC0CKSEL021	IC0CKSEL020	Description																														
0	0	TAUJ0 timer channel 0																														
0	1	TAUJ0 timer channel 1																														
1	0	TAUJ0 timer channel 2																														
1	1	TAUJ0 timer channel 3																														
3 to 0	IC0CKSEL000 to IC0CKSEL003	Select a counter-clock-enable signal for input to OSTM0. x = 0 <table border="1"> <thead> <tr> <th>IC0CKSEL0x3</th><th>IC0CKSEL0x2</th><th>IC0CKSEL0x1</th><th>IC0CKSEL0x0</th><th>Description</th></tr> </thead> <tbody> <tr> <td>0</td><td>0</td><td>0</td><td>0</td><td>TAUBx timer channel 0</td></tr> <tr> <td>0</td><td>0</td><td>0</td><td>1</td><td>TAUBx timer channel 1</td></tr> <tr> <td>...</td><td>...</td><td>...</td><td>...</td><td>...</td></tr> <tr> <td>1</td><td>1</td><td>1</td><td>0</td><td>TAUBx timer channel 14</td></tr> <tr> <td>1</td><td>1</td><td>1</td><td>1</td><td>TAUBx timer channel 15</td></tr> </tbody> </table>	IC0CKSEL0x3	IC0CKSEL0x2	IC0CKSEL0x1	IC0CKSEL0x0	Description	0	0	0	0	TAUBx timer channel 0	0	0	0	1	TAUBx timer channel 1	1	1	1	0	TAUBx timer channel 14	1	1	1	1	TAUBx timer channel 15
IC0CKSEL0x3	IC0CKSEL0x2	IC0CKSEL0x1	IC0CKSEL0x0	Description																												
0	0	0	0	TAUBx timer channel 0																												
0	0	0	1	TAUBx timer channel 1																												
...																												
1	1	1	0	TAUBx timer channel 14																												
1	1	1	1	TAUBx timer channel 15																												

- Caution 1. Select a counter-clock-enable signal for OSTMn while the operation of OSTMn is stopped (the OSTMnTE.OSTMnTE bit is 0).
- Caution 2. After using the IC0CKSELn.IC0CKSELn[13:0] bits to select the counter-clock-enable signal for OSTMn, set the IC0CKSELn.IC0TMENn bit to 1.
- Caution 3. If TAUBn or TAUJn is selected as the source of a counter-clock-enable signal for OSTMn (the IC0CKSELn.IC0TMENn bit is 1), do not change the operation of TAUBn or TAUJn while the OSTMn is operating (the OSTMnTE.OSTMnTE bit is 1).

[Setting procedure]

- (1) Confirm that the OSTMnTE.OSTMnTE bit is 0 (OSTMn operation is stopped).
 - (2) Set the IC0CKSELn.IC0CKSELn[13:0] bits to select a counter-clock-enable signal for the OSTMn.
 - (3) Set the IC0CKSELn.IC0TMENn bit to 1.
 - (4) Enable OSTMn operation by setting the OSTMnTS.OSTMnTS bit to 1.
-

(10) IC0CKSEL1 - OSTM Input Clock Select Function Register 1

This register is used to select the clock-enable signal for the counter clock of OSTM1.

Access This register is readable/writable in 16-bit units.

Address FF83F004_H

Initial value 0000_H

This register is initialized by a reset from any source.

15	14	13	12	11	10	9	8	7	6	5	4	3	2	1	0
IC0TMEN1	0	IC0TMS EL11	IC0TMS EL10	0	0	IC0CKSEL121	IC0CKSEL120	0	0	0	0	IC0CKSEL103	IC0CKSEL102	IC0CKSEL101	IC0CKSEL100
R/W	R	R/W	R/W	R	R	R/W	R/W	R	R	R	R	R/W	R/W	R/W	R/W

Table 17-19 IC0CKSEL1 Register Contents

Bit Position	Bit Name	Function																														
15	IC0TMEN1	Selects output of the counter-clock-enable signal. <table border="1"> <thead> <tr> <th>IC0TMEN1</th> <th>Description</th> </tr> </thead> <tbody> <tr> <td>0</td> <td>Input the high level as the counter-clock-enable signal for the OSTM1.</td> </tr> <tr> <td>1</td> <td>Input the counter-clock-enable signal selected by IC0TMSEL10 and IC0TMSEL11 to OSTM1.</td> </tr> </tbody> </table>	IC0TMEN1	Description	0	Input the high level as the counter-clock-enable signal for the OSTM1.	1	Input the counter-clock-enable signal selected by IC0TMSEL10 and IC0TMSEL11 to OSTM1.																								
IC0TMEN1	Description																															
0	Input the high level as the counter-clock-enable signal for the OSTM1.																															
1	Input the counter-clock-enable signal selected by IC0TMSEL10 and IC0TMSEL11 to OSTM1.																															
13,12	IC0TMSEL10, IC0TMSEL11	According to the setting, these bits select the timer signal indicated below as the counter-clock-enable signal (from among the counter-clock-enable signals selected by bits 11 to 0). <table border="1"> <thead> <tr> <th>IC0TMSEL11</th> <th>IC0TMSEL10</th> <th>Description</th> </tr> </thead> <tbody> <tr> <td>0</td> <td>0</td> <td>TAUB0</td> </tr> <tr> <td>0</td> <td>1</td> <td>Setting prohibited</td> </tr> <tr> <td>1</td> <td>0</td> <td>TAUJ0</td> </tr> <tr> <td>1</td> <td>1</td> <td>Setting prohibited</td> </tr> </tbody> </table>	IC0TMSEL11	IC0TMSEL10	Description	0	0	TAUB0	0	1	Setting prohibited	1	0	TAUJ0	1	1	Setting prohibited															
IC0TMSEL11	IC0TMSEL10	Description																														
0	0	TAUB0																														
0	1	Setting prohibited																														
1	0	TAUJ0																														
1	1	Setting prohibited																														
9,8	IC0CKSEL120, IC0CKSEL121	Select a counter-clock-enable signal for input to OSTM1. <table border="1"> <thead> <tr> <th>IC0CKSEL121</th> <th>IC0CKSEL120</th> <th>Description</th> </tr> </thead> <tbody> <tr> <td>0</td> <td>0</td> <td>TAUJ0 timer channel 0</td> </tr> <tr> <td>0</td> <td>1</td> <td>TAUJ0 timer channel 1</td> </tr> <tr> <td>1</td> <td>0</td> <td>TAUJ0 timer channel 2</td> </tr> <tr> <td>1</td> <td>1</td> <td>TAUJ0 timer channel 3</td> </tr> </tbody> </table>	IC0CKSEL121	IC0CKSEL120	Description	0	0	TAUJ0 timer channel 0	0	1	TAUJ0 timer channel 1	1	0	TAUJ0 timer channel 2	1	1	TAUJ0 timer channel 3															
IC0CKSEL121	IC0CKSEL120	Description																														
0	0	TAUJ0 timer channel 0																														
0	1	TAUJ0 timer channel 1																														
1	0	TAUJ0 timer channel 2																														
1	1	TAUJ0 timer channel 3																														
3 to 0	IC0CKSEL100 to IC0CKSEL103	Select a counter-clock-enable signal for input to OSTM1. <table border="1"> <thead> <tr> <th>IC0CKSEL1x3</th> <th>IC0CKSEL1x2</th> <th>IC0CKSEL1x1</th> <th>IC0CKSEL1x0</th> <th>Description</th> </tr> </thead> <tbody> <tr> <td>0</td> <td>0</td> <td>0</td> <td>0</td> <td>TAUBx timer channel 0</td> </tr> <tr> <td>0</td> <td>0</td> <td>0</td> <td>1</td> <td>TAUBx timer channel 1</td> </tr> <tr> <td>...</td> <td>...</td> <td>...</td> <td>...</td> <td>...</td> </tr> <tr> <td>1</td> <td>1</td> <td>1</td> <td>0</td> <td>TAUBx timer channel 14</td> </tr> <tr> <td>1</td> <td>1</td> <td>1</td> <td>1</td> <td>TAUBx timer channel 15</td> </tr> </tbody> </table>	IC0CKSEL1x3	IC0CKSEL1x2	IC0CKSEL1x1	IC0CKSEL1x0	Description	0	0	0	0	TAUBx timer channel 0	0	0	0	1	TAUBx timer channel 1	1	1	1	0	TAUBx timer channel 14	1	1	1	1	TAUBx timer channel 15
IC0CKSEL1x3	IC0CKSEL1x2	IC0CKSEL1x1	IC0CKSEL1x0	Description																												
0	0	0	0	TAUBx timer channel 0																												
0	0	0	1	TAUBx timer channel 1																												
...																												
1	1	1	0	TAUBx timer channel 14																												
1	1	1	1	TAUBx timer channel 15																												

- Caution 1. Select a counter-clock-enable signal for OSTMn while the operation of OSTMn is stopped (the OSTMnTE.OSTMnTE bit is 0).
- Caution 2. After using the IC0CKSELn.IC0CKSELn[13:0] bits to select the counter-clock-enable signal for OSTMn, set the IC0CKSELn.IC0TMENn bit to 1.
- Caution 3. If TAUBn or TAUJn is selected as the source of a counter-clock-enable signal for OSTMn (the IC0CKSELn.IC0TMENn bit is 1), do not change the operation of TAUBn or TAUJn while the OSTMn is operating (the OSTMnTE.OSTMnTE bit is 1).

[Setting procedure]

- (1) Confirm that the OSTMnTE.OSTMnTE bit is 0 (OSTMn operation is stopped).
 - (2) Set the IC0CKSELn.IC0CKSELn[13:0] bits to select a counter-clock-enable signal for the OSTMn.
 - (3) Set the IC0CKSELn.IC0TMENn bit to 1.
 - (4) Enable OSTMn operation by setting the OSTMnTS.OSTMnTS bit to 1.
-

Section 18 Encoder Timer (ENCA)

18.1 ENCA Features

Instances This product has 1 encoder timer.

Table 18-1 Instances of ENCA

Encoder Timer	
Instance	1
Name	ENCA0

Instances index n Throughout this section, both of the individual encoder timers are indicated by the index "n" (where n = 0). For example, ENCA_nCTL indicates both ENCA_n control registers.

Meaning of both edges In this section, "both edges" refers to both rising and falling edges.

Register addresses All ENCA_n register addresses are given as address offsets to the individual base address <ENCA_n_base>. The base address <ENCA_n_base> of each ENCA_n is listed in the following table:

Table 18-2 Register Base Addresses <ENCA_n_base>

ENCA _n Instance	<ENCA _n _base0> Address	<ENCA _n _base1> Address
ENCA0	FF81 9000 _H	FFFF D800 _H

Clock supply The following clock input is provided to each ENCA_n. That is, each ENCA_n is connected to the PCLK.

Table 18-3 ENCA_n Clock Supply

ENCA _n Instance	Clock Supply
ENCA0	PCLK

Interrupt requests Interrupt requests from ENCA_n are listed in the following table:

Table 18-4 List of ENCA_n Interrupt Requests

ENCA _n Signals	Function	Connected to
INTENCA _n IOV	Overflow interrupt	Interrupt controller, DMA
INTENCA _n IUD	Underflow interrupt	Interrupt controller, DMA
INTENCA _n I0	Compare match 0 or capture 0 interrupt	Interrupt controller, DMA
INTENCA _n I1	Compare match 1 or capture 1 interrupt	Interrupt controller, DMA
INTENCA _n IEC	Interrupt to indicate clearing due to clearing input from the encoder	Interrupt controller, DMA

Input signals Input signals of ENCA_n are listed in the following table:

Table 18-5 List of ENCA_n Input Signals

ENCA _n Signals	Function	Connected to
ENCA _n I0	ENCA _n capture trigger input 0	—
ENCA _n I1	ENCA _n capture trigger input 1	PIC function (input)
ENCA _n E0	ENCA _n encoder input 0	Port
ENCA _n E1	ENCA _n encoder input 1	Port
ENCA _n EC	ENCA _n encoder clearing input	Port
ENCA _n TSST	ENCA _n simultaneous start trigger input	PIC module (input)

18.2 Functional Overview

**Features
summary**

- Generates a counter control signal from the encoder input signal and executes counting in synchronization with PCLK.
- Capture function for capturing the counter value with an external trigger signal
- Compare function for compare match judgment with the counter value
- Two capture compare registers that can be set separately for capture operation and for compare operation
- Interrupt masking function for masking the output of interrupt signals as a result of a match in judgment by comparison
- Function for loading the value of the capture-compare register to the counter when the latter underflows
- An input signal from an encoder can be applied as the clearing condition for the timer counter.
- Edge or level detection is selectable for the encoder input signal that provides the clearing condition for the timer counter.
- Five interrupt outputs: 2 capture-compare interrupts, 1 counter-clear interrupt, 1 overflow interrupt, and 1 underflow interrupt.

18.2.1 Block Diagram

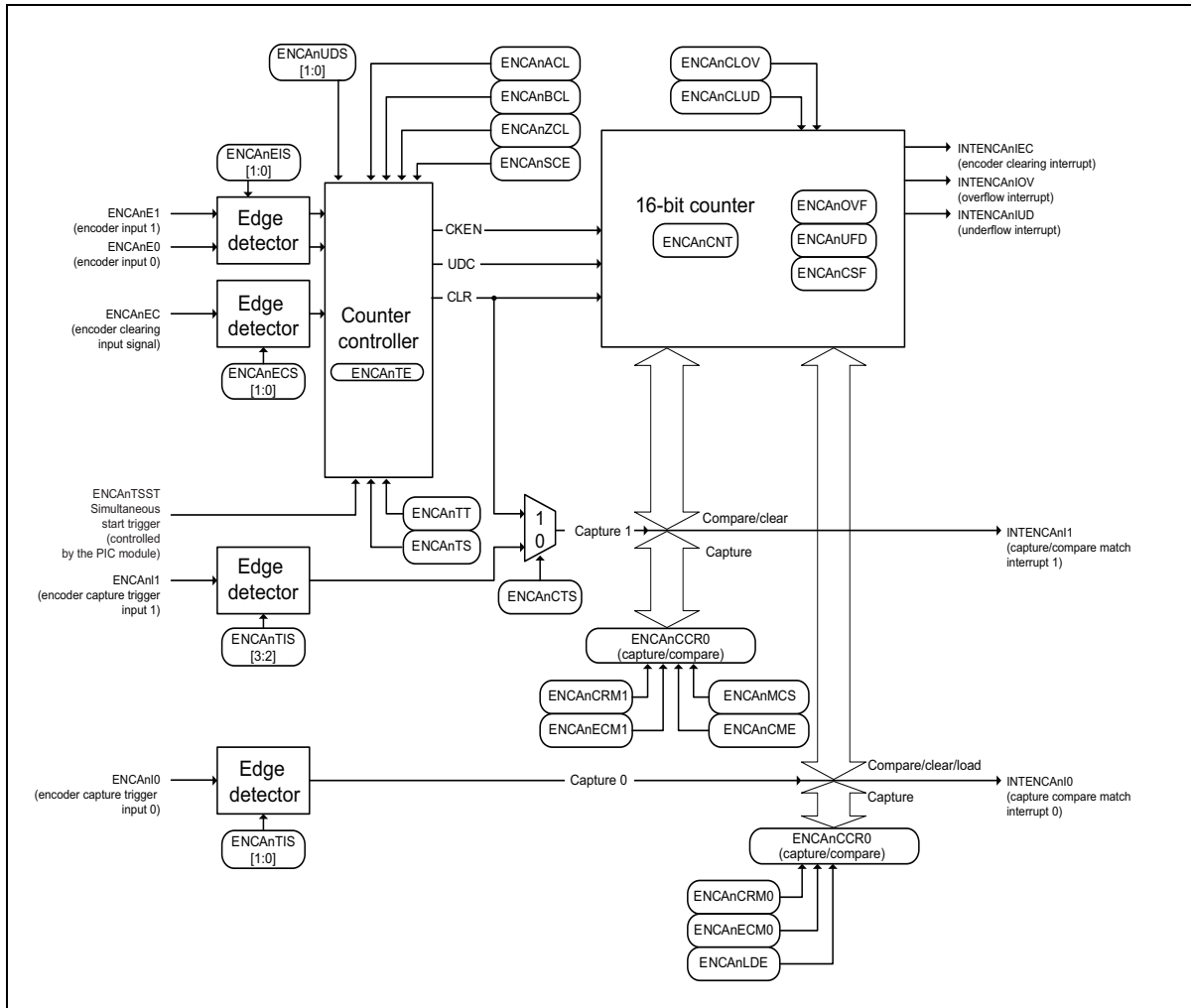

Figure 18-1 Block Diagram of Encoder Timer

18.3 ENCA Control Registers

The ENCA_n is controlled and operated by the following registers:

Table 18-6 ENCA_n Register Overview

Register Function	Name	Address
ENCA _n capture/compare register 0	ENCA _n CCR0	<ENCA _n _base1>
ENCA _n capture/compare register 1	ENCA _n CCR1	<ENCA _n _base1> + 04 _H
ENCA _n counter register	ENCA _n CNT	<ENCA _n _base1> + 08 _H
ENCA _n status flag register	ENCA _n FLG	<ENCA _n _base1> + 0C _H
ENCA _n status flag clear register	ENCA _n FGC	<ENCA _n _base1> + 10 _H
ENCA _n timer enable status register	ENCA _n TE	<ENCA _n _base1> + 14 _H
ENCA _n timer start trigger register	ENCA _n TS	<ENCA _n _base1> + 18 _H
ENCA _n timer stop trigger register	ENCA _n TT	<ENCA _n _base1> + 1C _H
ENCA _n I/O control register 0	ENCA _n IOC0	<ENCA _n _base1> + 20 _H
ENCA _n control register	ENCA _n CTL	<ENCA _n _base0> + 40 _H
ENCA _n I/O control register 1	ENCA _n IOC1	<ENCA _n _base0> + 44 _H

<ENCA_n_base> The base address <ENCA_n_base> for each ENCA_n is defined in Section 18.1, under "Register addresses".

(1) ENCA_nCTL – ENCA Control Register

This register is a 16-bit register that controls operation of the encoder timer.

Access This register can be read/written in 16-bit units.
Writing to this register during operation is prohibited.

Address <ENCA_n_base0> + 40_H

Initial value 0000_H

A reset from any source will initialize the bits.

15	14	13	12	11	10	9	8
ENCA _n CME	ENCA _n MCS	0	0	0	0	ENCA _n CRM1	ENCA _n CRM0
R/W	R/W	R	R	R	R	R/W	R/W
7	6	5	4	3	2	1	0
ENCA _n CTS	0	0	ENCA _n LDE	ENCA _n ECM1	ENCA _n ECM0	ENCA _n UDS[1:0]	
R/W	R	R	R/W	R/W	R/W	R/W	R/W

Table 18-7 ENCA_nCTL Register Contents (1/3)

Bit Position	Bit Name	Function
15	ENCA _n CME	This bit is used to enable or disable masking of compare 1 match interrupt detection when the compare function by ENCA _n CCR1 register is used. 0: Disables masking. 1: Enables masking. Caution 1. The setting of the ENCA _n CME bit is only valid when ENCA _n CRM1 = 0. Caution 2. While the ENCA _n CME bit is set to 1, setting ENCA _n ECM1 to 1 is prohibited.
14	ENCA _n MCS	This bit is used to select the trigger for canceling masking of compare 1 match interrupt detection when the compare function by ENCA _n CCR1 register is used. 0: Masking of compare match interrupt detection is canceled when the ENCA _n CCR1 register is written. 1: Masking of compare match interrupt detection is canceled when one of the following three operations is performed. - Timer counter clearing in response to the clearing input signal from the encoder. - Timer counter clearing upon compare match between ENCA _n CNT and ENCA _n CCR0 when ENCA _n ECM0 = 1 - Loading from ENCA _n CCR0 to timer counter upon underflow detection when ENCA _n LDE = 1 Caution: The setting of the ENCA _n MCS bit is only valid when ENCA _n CRM1 = 0.
9	ENCA _n CRM1	This bit selects how the ENCA _n CCR1 register is to be used. 0: Selects the use of ENCA _n CCR1 as a comparison register. 1: Selects the use of ENCA _n CCR1 as a capture register.
8	ENCA _n CRM0	This bit selects how the ENCA _n CCR0 register is to be used. 0: Selects the use of ENCA _n CCR0 as a comparison register. 1: Selects the use of ENCA _n CCR0 as a capture register.

Table 18-7 ENCA_nCTL Register Contents (2/3)

Bit Position	Bit Name	Function
7	ENCA _n CTS	<p>This bit selects the trigger for capture by the ENCA_nCCR1 register.</p> <p>0: The ENCA_nI1 input is the capture trigger. 1: The ENCA_nEC input is the capture trigger.</p> <p>Caution: The setting of the ENCA_nCTS bit is only valid when ENCA_nCRM1 = 1.</p>
4	ENCA _n LDE	<p>This bit is used to enable or disable the loading of settings of the ENCA_nCCR0 register to the counter when the counter underflows.</p> <p>0: Disable loading to the counter. 1: Enable loading to the counter.</p> <p>Caution 1. The setting of the ENCA_nLDE bit is only valid when ENCA_nCRM0 = 0. Caution 2. When ENCA_nCRM0 = 1, the value in the ENCA_nCCR0 register is not loaded to the counter when the counter underflows, regardless of the value of the ENCA_nLDE bit.</p>
3	ENCA _n ECM1	<p>This bit is used to select or deselect counter-clearing upon matches between the values in the counter and in register ENCA_nCCR1.</p> <p>0: The counter is not cleared to 0000_H. 1: The counter is cleared to 0000_H if the next step in counting is counting down.</p> <p>Caution: The setting of the ENCA_nECM1 bit is only valid when ENCA_nCRM1 = 0.</p>
2	ENCA _n ECM0	<p>This bit is used to select or deselect counter-clearing upon matches between the values in the counter and in register ENCA_nCCR0.</p> <p>0: The counter is not cleared to 0000_H. 1: The counter is cleared to 0000_H if the next step in counting is counting up.</p> <p>Caution: The setting of the ENCA_nECM0 bit is only valid when ENCA_nCRM0 = 0.</p>

Table 18-7 ENCA_nCTL Register Contents (3/3)

Bit Position	Bit Name	Function															
1, 0	ENCA _n UDS1, ENCA _n UDS0	<p>Along with the inputs on the ENCA_nE0 and ENCA_nE1 pins, these bits control whether counting is up or down.</p> <table border="1"> <thead> <tr> <th>ENCA_nUDS1</th> <th>ENCA_nUDS0</th> <th>Operation</th> </tr> </thead> <tbody> <tr> <td>0</td> <td>0</td> <td> <p>Upon detection of a valid edge in the ENCA_nE0 input signal from the encoder, counter operation depends on the state of the ENCA_nE1 input signal from the encoder. Counting will be</p> <ul style="list-style-type: none"> down if ENCA_nE1 is "high" and up if ENCA_nE1 is "low". </td> </tr> <tr> <td>0</td> <td>1</td> <td> <ul style="list-style-type: none"> Detection of a valid edge in the ENCA_nE0 encoder input causes counting up. Detection of a valid edge in the ENCA_nE1 encoder input causes counting down. </td> </tr> <tr> <td>1</td> <td>0</td> <td> <ul style="list-style-type: none"> A rising edge of the ENCA_nE0 encoder input causes counting down. A falling edge of the ENCA_nE0 encoder input causes counting up. <p>However, counting in either direction only proceeds when ENCA_nE1 is low.</p> </td> </tr> <tr> <td>1</td> <td>1</td> <td> <p>Both edges are detected in encoder inputs ENCA_nE0 and ENCA_nE1. The combination of detected edge and input level determines the counting operation.</p> </td> </tr> </tbody> </table>	ENCA _n UDS1	ENCA _n UDS0	Operation	0	0	<p>Upon detection of a valid edge in the ENCA_nE0 input signal from the encoder, counter operation depends on the state of the ENCA_nE1 input signal from the encoder. Counting will be</p> <ul style="list-style-type: none"> down if ENCA_nE1 is "high" and up if ENCA_nE1 is "low". 	0	1	<ul style="list-style-type: none"> Detection of a valid edge in the ENCA_nE0 encoder input causes counting up. Detection of a valid edge in the ENCA_nE1 encoder input causes counting down. 	1	0	<ul style="list-style-type: none"> A rising edge of the ENCA_nE0 encoder input causes counting down. A falling edge of the ENCA_nE0 encoder input causes counting up. <p>However, counting in either direction only proceeds when ENCA_nE1 is low.</p>	1	1	<p>Both edges are detected in encoder inputs ENCA_nE0 and ENCA_nE1. The combination of detected edge and input level determines the counting operation.</p>
ENCA _n UDS1	ENCA _n UDS0	Operation															
0	0	<p>Upon detection of a valid edge in the ENCA_nE0 input signal from the encoder, counter operation depends on the state of the ENCA_nE1 input signal from the encoder. Counting will be</p> <ul style="list-style-type: none"> down if ENCA_nE1 is "high" and up if ENCA_nE1 is "low". 															
0	1	<ul style="list-style-type: none"> Detection of a valid edge in the ENCA_nE0 encoder input causes counting up. Detection of a valid edge in the ENCA_nE1 encoder input causes counting down. 															
1	0	<ul style="list-style-type: none"> A rising edge of the ENCA_nE0 encoder input causes counting down. A falling edge of the ENCA_nE0 encoder input causes counting up. <p>However, counting in either direction only proceeds when ENCA_nE1 is low.</p>															
1	1	<p>Both edges are detected in encoder inputs ENCA_nE0 and ENCA_nE1. The combination of detected edge and input level determines the counting operation.</p>															

(2) ENCA_nIOC0 – ENCA I/O Control Register 0

This is an 8-bit register for use to control the valid edge in the input of capture triggers 0 and 1 (i.e. input signals ENCA_nI0 and ENCA_nI1).

Access This register can be read/written in 8-bit units.

Address <ENCA_n_base1> + 20_H

Initial value 00_H

A reset from any source will initialize the bits.

	7	6	5	4	3	2	1	0
	0	0	0	0	ENCA _n TIS[3:2]		ENCA _n TIS[1:0]	
	R	R	R	R	R/W	R/W	R/W	R/W

Table 18-8 ENCA_nIOC0 Register Contents

Bit Position	Bit Name	Function															
3, 2	ENCA _n TIS3, ENCA _n TIS2	Selects the valid edge of capture trigger 1 (ENCA _n I1). <table border="1" style="width: 100%; margin-top: 10px; border-collapse: collapse;"> <thead> <tr> <th style="width: 15%;">ENCA_n TIS3</th> <th style="width: 15%;">ENCA_n TIS2</th> <th style="width: 70%;">Operation</th> </tr> </thead> <tbody> <tr> <td>0</td> <td>0</td> <td>Neither edge is detected.</td> </tr> <tr> <td>0</td> <td>1</td> <td>Rising edges are detected.</td> </tr> <tr> <td>1</td> <td>0</td> <td>Falling edges are detected.</td> </tr> <tr> <td>1</td> <td>1</td> <td>Both edges are detected.</td> </tr> </tbody> </table> <p style="font-size: small; margin-top: 10px;">Caution: Settings in these bits are only valid when ENCA_nCTL.ENCA_nCRM1 = 1 and ENCA_nCTS = 0. The settings are invalid with any other settings of ENCA_nCRM1 and ENCA_nCTS.</p>	ENCA _n TIS3	ENCA _n TIS2	Operation	0	0	Neither edge is detected.	0	1	Rising edges are detected.	1	0	Falling edges are detected.	1	1	Both edges are detected.
ENCA _n TIS3	ENCA _n TIS2	Operation															
0	0	Neither edge is detected.															
0	1	Rising edges are detected.															
1	0	Falling edges are detected.															
1	1	Both edges are detected.															
1, 0	ENCA _n TIS1, ENCA _n TIS0	Selects the valid edge of capture trigger 0 (ENCA _n I0). <table border="1" style="width: 100%; margin-top: 10px; border-collapse: collapse;"> <thead> <tr> <th style="width: 15%;">ENCA_n TIS1</th> <th style="width: 15%;">ENCA_n TIS0</th> <th style="width: 70%;">Operation</th> </tr> </thead> <tbody> <tr> <td>0</td> <td>0</td> <td>Neither edge is detected.</td> </tr> <tr> <td>0</td> <td>1</td> <td>Rising edges are detected.</td> </tr> <tr> <td>1</td> <td>0</td> <td>Falling edges are detected.</td> </tr> <tr> <td>1</td> <td>1</td> <td>Both edges are detected.</td> </tr> </tbody> </table> <p style="font-size: small; margin-top: 10px;">Caution: Settings in these bits are only valid when ENCA_nCTL.ENCA_nCRM0 = 1.</p>	ENCA _n TIS1	ENCA _n TIS0	Operation	0	0	Neither edge is detected.	0	1	Rising edges are detected.	1	0	Falling edges are detected.	1	1	Both edges are detected.
ENCA _n TIS1	ENCA _n TIS0	Operation															
0	0	Neither edge is detected.															
0	1	Rising edges are detected.															
1	0	Falling edges are detected.															
1	1	Both edges are detected.															

(3) ENCA_nIOC1 – ENCA I/O Control Register 1

This is an 8-bit register that controls the clearing condition and valid edges for the input and clearing input signals from the encoder (ENCA_nE0, ENCA_nE1 and ENCA_nEC).

Access This register can be read/written in 8-bit units.
Writing to this register during operation is prohibited.

Address <ENCA_n_base0> + 44_H

Initial value 00_H

A reset from any source will initialize the bits

7	6	5	4	3	2	1	0
ENCA _n SCE	ENCA _n ZCL	ENCA _n BCL	ENCA _n ACL	ENCA _n ECS[1:0]		ENCA _n EIS[1:0]	
R/W	R/W	R/W	R/W	R/W	R/W	R/W	R/W

Table 18-9 ENCA_nIOC1 Register Contents (1/2)

Bit Position	Bit Name	Function
7	ENCA _n SCE	<p>This bit selects the method for clearing of the encoder counter.</p> <p>0: Detection of any valid edge in ENCA_nEC causes clearing.</p> <p>1: Detection of the level of ENCA_nEC selected as the clearing condition causes clearing.</p> <p>When ENCA_nSCE = 0, settings of the ENCA_nZCL, ENCA_nACL, and ENCA_nBCL bits become ineffective, and settings of the ENCA_nECS1 and ENCA_nECS0 bits become effective.</p> <p>The counter is cleared to 0000_H when ENCA_nSCE = 1 and the clearing conditions set in the ENCA_nZCL, ENCA_nACL, and ENCA_nBCL bits are all matched (settings of the ENCA_nECS1 and ENCA_nECS0 bits become ineffective).</p> <p>Caution: When ENCA_nSCE = 1, set bits ENCA_nUDS1 and ENCA_nUDS0 to 10_B or 11_B.</p>
6	ENCA _n ZCL	<p>This bit is used to set the active level for clearing in the ENCA_nEC encoder-clearing input signal.</p> <p>0: Clearing condition: Low level</p> <p>1: Clearing condition: High level</p> <p>Caution: This bit is valid when ENCA_nSCE = 1.</p>
5	ENCA _n BCL	<p>This bit is used to set the active level for clearing in the ENCA_nE1 encoder input signal.</p> <p>0: Clearing condition: Low level</p> <p>1: Clearing condition: High level</p> <p>Caution: This bit is valid when ENCA_nSCE = 1.</p>
4	ENCA _n ACL	<p>This bit is used to set the active level for clearing in the ENCA_nE0 encoder input signal.</p> <p>0: Clearing condition: Low level</p> <p>1: Clearing condition: High level</p> <p>Caution: This bit is valid when ENCA_nSCE = 1.</p>

Table 18-9 ENCA_nIOC1 Register Contents (2/2)

Bit Position	Bit Name	Function															
3, 2	ENCA _n ECS1, ENCA _n ECS0	These bits set the valid edge of the encoder-clearing input signal (ENCA _n EC).															
		<table border="1"> <thead> <tr> <th>ENCA_nECS1</th> <th>ENCA_nECS0</th> <th>Operation</th> </tr> </thead> <tbody> <tr> <td>0</td> <td>0</td> <td>Neither edge is detected.</td> </tr> <tr> <td>0</td> <td>1</td> <td>Rising edges are detected.</td> </tr> <tr> <td>1</td> <td>0</td> <td>Falling edges are detected.</td> </tr> <tr> <td>1</td> <td>1</td> <td>Both edges are detected.</td> </tr> </tbody> </table>	ENCA _n ECS1	ENCA _n ECS0	Operation	0	0	Neither edge is detected.	0	1	Rising edges are detected.	1	0	Falling edges are detected.	1	1	Both edges are detected.
		ENCA _n ECS1	ENCA _n ECS0	Operation													
		0	0	Neither edge is detected.													
		0	1	Rising edges are detected.													
		1	0	Falling edges are detected.													
1	1	Both edges are detected.															
Caution: These bits are valid when ENCA _n SCE bit = 0.																	
1, 0	ENCA _n EIS1, ENCA _n EIS0	These bits set the valid edge for input signals from the encoder (signals on the ENCA _n E0 and ENCA _n E1 pins).															
		<table border="1"> <thead> <tr> <th>ENCA_nEIS1</th> <th>ENCA_nEIS0</th> <th>Operation</th> </tr> </thead> <tbody> <tr> <td>0</td> <td>0</td> <td>Neither edge is detected.</td> </tr> <tr> <td>0</td> <td>1</td> <td>Rising edges are detected.</td> </tr> <tr> <td>1</td> <td>0</td> <td>Falling edges are detected.</td> </tr> <tr> <td>1</td> <td>1</td> <td>Both edges are detected.</td> </tr> </tbody> </table>	ENCA _n EIS1	ENCA _n EIS0	Operation	0	0	Neither edge is detected.	0	1	Rising edges are detected.	1	0	Falling edges are detected.	1	1	Both edges are detected.
		ENCA _n EIS1	ENCA _n EIS0	Operation													
		0	0	Neither edge is detected.													
		0	1	Rising edges are detected.													
		1	0	Falling edges are detected.													
1	1	Both edges are detected.															
Caution: These bits are valid when the ENCA _n UDS1 and ENCA _n UDS0 bits are 00 _B or 01 and invalid when the ENCA _n UDS1 and ENCA _n UDS0 are 10 _B or 11 _B .																	

(4) ENCA_nFLG – ENCA Status Flag Register

This 8-bit flag register indicates the state of the timer counter for the encoder.

Access This register is read-only and readable in 8-bit units.

Address <ENCA_n_base1> + 0C_H

Initial value 00_H

A reset from any source will initialize the bits.

7	6	5	4	3	2	1	0
0	0	0	0	0	ENCA _n CSF	ENCA _n UDF	ENCA _n OVF
R	R	R	R	R	R	R	R

Table 18-10 ENCA_nFLG Register Contents

Bit Position	Bit Name	Function
2	ENCA _n CSF	<p>This bit is a flag that indicates whether the timer counter is counting up or down.</p> <p>0: Counting up 1: Counting down</p> <p>Caution: This bit is cleared at the start of counting operations.</p>
1	ENCA _n UDF	<p>This bit is a flag that indicates if an underflow has or has not occurred during timer-counter operations.</p> <p>The value of the 16-bit counter changing from 0000_H to FFFF_H is an underflow of the counter, and an underflow interrupt (INTENCA_nIUD) is also generated if the ENCA_nUDF flag is set to 1.</p> <p>Setting condition An underflow during encoder timer-counter operations causes setting of this flag to 1.</p> <p>Clearing condition Writing 1 to the ENCA_nCLUD bit of the ENCA_nFGC register, setting the ENCA_nTS bit to 1 while the ENCA_nTE bit = 0, or input of the synchronous start trigger signal (ENCA_nTSST signal) at the high level causes clearing of this flag to 0.</p> <p>Caution: This bit is cleared at the start of counting operations.</p>
0	ENCA _n OVF	<p>This bit is a flag that indicates if an overflow has or has not occurred during timer-counter operations.</p> <p>The value of the 16-bit counter changing from FFFF_H to 0000_H is an overflow of the counter, and an overflow interrupt (INTENCA_nIOV) is also generated if the ENCA_nOVF flag is set to 1.</p> <p>Setting condition An overflow during encoder timer-counter operations causes setting of this flag to 1.</p> <p>Clearing condition Writing 1 to the ENCA_nCLOV bit of the ENCA_nFGC register, setting the ENCA_nTS bit to 1 while the ENCA_nTE bit = 0, or input of the synchronous start trigger signal (ENCA_nTSST signal) at the high level causes clearing of this flag to 0.</p> <p>Caution: This bit is cleared at the start of counting operations.</p>

(5) ENCA_nFGC – ENCA Status Flag Clear Register

This register is an 8-bit register that controls clearing of the timer counter status flags in the ENCA_nFLG register.

Access This register can be written in 8-bit units.
This register always returns 00_H when read.

Address <ENCA_n_base1> + 10_H

Initial value 00_H

A reset from any source will initialize the bits.

7	6	5	4	3	2	1	0
0	0	0	0	0	0	ENCA _n CLUD	ENCA _n CLOV
R	R	R	R	R	R	W	W

Table 18-11 ENCA_nFGC Register Contents

Bit Position	Bit Name	Function
1	ENCA _n CLUD	This bit clears the underflow flag. 0: Invalid 1: Clears ENCA _n UDF of the ENCA _n FLG register (clears underflow detection).
0	ENCA _n CLOV	This bit clears the overflow flag. 0: Invalid 1: Clears ENCA _n OVF of the ENCA _n FLG register (clears overflow detection).

(6) ENCA_nCCR0 – ENCA Capture/Compare Register 0

This register is a 16-bit register that is used in both capture and comparison roles (i.e. to hold captured values or values for use in comparison).

Access This register can be read/written in 16-bit units.
 This register can be written in 16-bit units when used as a comparison register (ENCA_nCTL.ENCA_nCRM0 = 0). When used as a capture register (ENCA_nCTL.ENCA_nCRM0 = 1), writing to this register during operation is invalid.

Address <ENCA_n_base1> + 00_H

Initial value 0000_H

A reset from any source will initialize the bits.

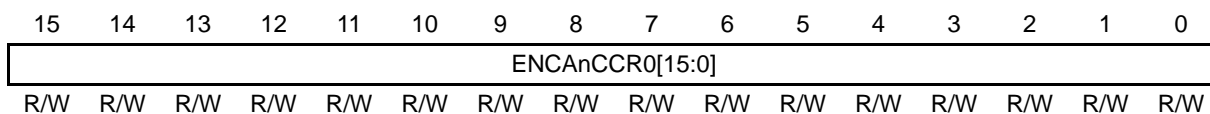

Table 18-12 ENCA_nCCR0 Register Contents

Bit Position	Bit Name	Function
15 to 0	ENCA _n CCR0[15:0]	If ENCA _n CTL.ENCA _n CRM0 = 0, ENCA _n CCR0 is comparison register. Set the value to be compared with the timer counter value. If ENCA _n CTL.ENCA _n CRM0 = 1, ENCA _n CCR0 is capture register. The captured timer counter value is stored. Note: Upon occurrence of an underflow, the setting value of this register may be loaded to the counter according to the ENCA _n CTL.ENCA _n LDE setting. For details, refer to the description of the ENCA _n LDE bit in ENCA control register ENCA _n CTL.

(7) ENCA_nCCR1 – ENCA Capture/Compare Register 1

This register is a 16-bit register that is used in both capture and comparison roles (i.e. to hold captured values or values for use in comparison).

Access This register can be read/written in 16-bit units.
 This register can be written in 16-bit units when used as a comparison register (ENCA_nCTL.ENCA_nCRM1 = 0). When used as a capture register (ENCA_nCTL.ENCA_nCRM1 = 1), writing to this register during operation is invalid.

Address <ENCA_n_base1> + 04_H

Initial value 0000_H

A reset from any source will initialize the bits.

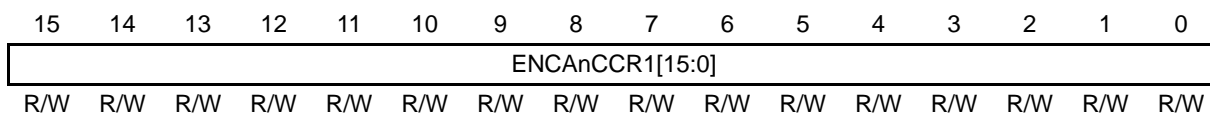

Table 18-13 ENCA_nCCR1 Register Contents

Bit Position	Bit Name	Function
15 to 0	ENCA _n CCR1[15:0]	If ENCA _n CTL.ENCA _n CRM1 = 0, ENCA _n CCR1 is comparison register. Set the value to be compared with the timer counter value. If ENCA _n CTL.ENCA _n CRM1 = 1, ENCA _n CCR1 is capture register. The captured timer counter value is stored. Note: During capture operation, the trigger for capturing to this register differs according to the ENCA _n CTL.ENCA _n CTS setting. For details, refer to the description of the ENCA _n CTS bit in ENCA control register ENCA _n CTL.

(8) ENCA_nCNT – ENCA Counter Register

This register is a 16-bit timer counter.

Access This register can be read/written in 16-bit units.
 This register can be written only when the counting operation is stopped.
 Writing to this register during counting operation is invalid.

Address <ENCA_n_base1> + 08_H

Initial value 0000_H

A reset from any source will initialize the bits.

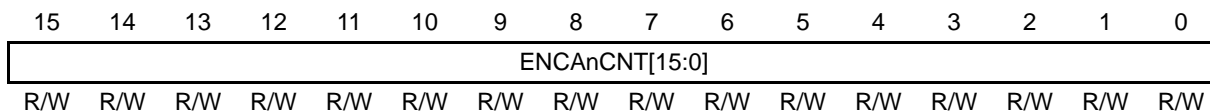

Table 18-14 ENCA_nCNT Register Contents

Bit Position	Bit Name	Function															
15 to 0	ENCA _n CNT [15:0]	Operation of counter register <table border="1" style="width: 100%; margin-top: 10px; border-collapse: collapse;"> <thead> <tr style="background-color: #cccccc;"> <th style="width: 20%;">ENCA_nTE</th> <th style="width: 20%;">Counter Status</th> <th style="width: 60%;">Operation</th> </tr> </thead> <tbody> <tr> <td style="text-align: center;">0</td> <td style="text-align: center;">Stopped (initial setting)</td> <td>Set a given value to timer counter register.</td> </tr> <tr> <td style="text-align: center;">0→1</td> <td style="text-align: center;">Starting operation</td> <td>Start counting up/down from the set given value.</td> </tr> <tr> <td style="text-align: center;">1</td> <td style="text-align: center;">In operation</td> <td>Counting up/down</td> </tr> <tr> <td style="text-align: center;">1→0</td> <td style="text-align: center;">Stopped</td> <td>Counting stopped (retains its value before counting stopped).</td> </tr> </tbody> </table> <p style="font-size: small; margin-top: 5px;">Note: ENCA_nTE state refers to the state of the ENCA_nTE bit in the ENCA_nTE register.</p>	ENCA _n TE	Counter Status	Operation	0	Stopped (initial setting)	Set a given value to timer counter register.	0→1	Starting operation	Start counting up/down from the set given value.	1	In operation	Counting up/down	1→0	Stopped	Counting stopped (retains its value before counting stopped).
ENCA _n TE	Counter Status	Operation															
0	Stopped (initial setting)	Set a given value to timer counter register.															
0→1	Starting operation	Start counting up/down from the set given value.															
1	In operation	Counting up/down															
1→0	Stopped	Counting stopped (retains its value before counting stopped).															

(9) ENCA_nTE – ENCA Timer Enable Status Register

This 8-bit register indicates the state of operation of the encoder timer.

Access This register is read-only and readable in 8-bit units.

Address <ENCA_n_base1> + 14_H

Initial value 00_H

A reset from any source will initialize the bits.

7	6	5	4	3	2	1	0
0	0	0	0	0	0	0	ENCA _n TE
R	R	R	R	R	R	R	R

Table 18-15 ENCA_nTE Register Contents

Bit Position	Bit Name	Function
0	ENCA _n TE	<p>This is a status bit that indicates the operation enabled/stopped status of the encoder timer.</p> <p>0: Operation stopped status 1: Operation enabled status</p> <p>Clearing condition This bit is cleared to 0 when 1 is written to ENCA_nTT.ENCA_nTT.</p> <p>Setting condition Writing of 1 to the ENCA_nTS.ENCA_nTS bit or the input of a high level of the simultaneous start trigger signal (ENCA_nTSST) causes setting of this bit to 1.</p>

(10) ENCA_nTS – ENCA Timer Start Trigger Register

This 8-bit register controls starting of the encoder timer.

Access This register can be read/written in 8-bit units. This register always returns 00_H when read. Writing to this register is only valid when ENCA_nTE.ENCA_nTE = 0.

Address <ENCA_n_base1> + 18_H

Initial value 00_H

A reset from any source will initialize the bits.

7	6	5	4	3	2	1	0
0	0	0	0	0	0	0	ENCA _n TS
R	R	R	R	R	R	R	W

Table 18-16 ENCA_nTS Register Contents

Bit Position	Bit Name	Function
0	ENCA _n TS	This is the trigger bit for placing the encoder timer in the operation-enabled state. 0: Invalid 1: Operation is enabled (ENCA _n TE.ENCA _n TE = 1 by setting ENCA _n TE.ENCA _n TS = 1.).

(11) ENCA_nTT – ENCA Timer Stop Trigger Register

This 8-bit register controls stopping of the encoder timer.

Access This register can be read/written in 8-bit units.
This register always returns 00_H when read.

Address <ENCA_n_base1> + 1C_H

Initial value 00_H

A reset from any source will initialize the bits.

7	6	5	4	3	2	1	0
0	0	0	0	0	0	0	ENCA _n TT
R	R	R	R	R	R	R	W

Table 18-17 ENCA_nTT Register Contents

Bit Position	Bit Name	Function
0	ENCA _n TT	This is the trigger bit for stopping ENCA _n operations. 0: Invalid 1: Operation is stopped (ENCA _n TE.ENCA _n TE = 0 by setting ENCA _n TT= 1.).

18.4 Functional Description

The encoder inputs and encoder-clearing input (ENCAnE0, ENCAnE1, and ENCAnEC) control the counter of ENCA_n by causing it to count up or down or by clearing it.

The ENCA_nCCR0 and ENCA_nCCR1 registers are available for use as comparison registers or as capture registers.

18.4.1 Timer Counter Operation

Operations of the encoder timer are described below.

The figure below shows the basic operations. For detailed descriptions of the individual types of operation, refer to the corresponding passages.

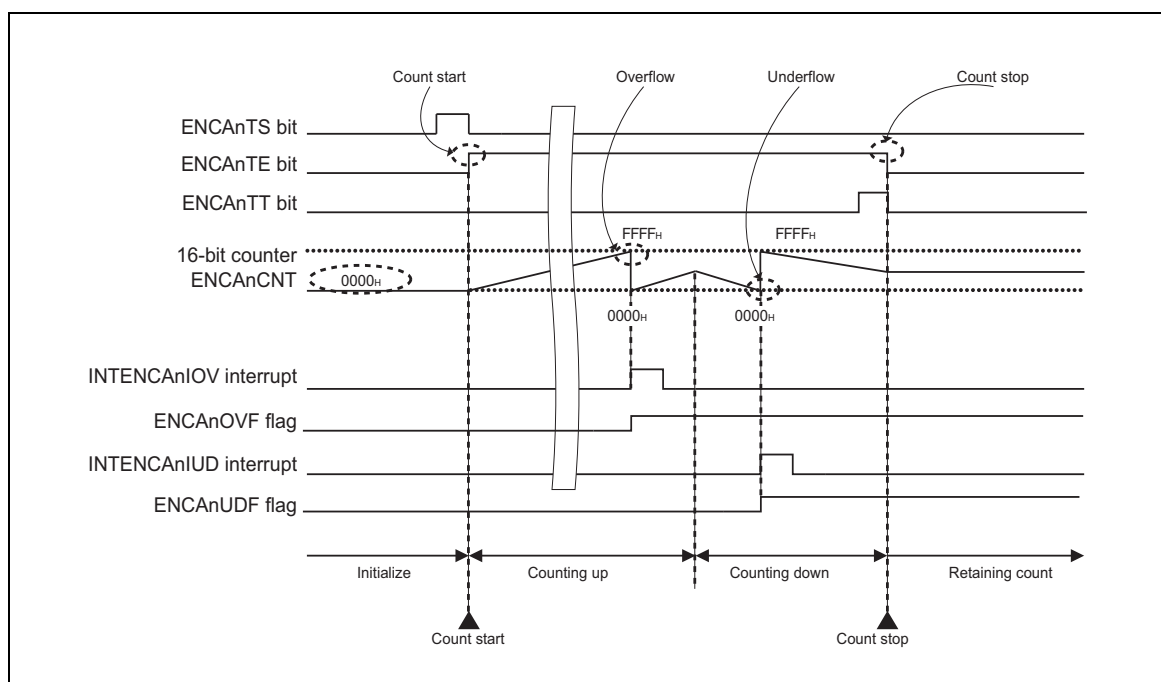

Figure 18-2 Timer Counter Initial Value Setting/Start/Stop

(1) Timer Counter Initial Value Setting

The initial value of the ENCA_n counter register (ENCA_nCNT) can be set in the counter operation stopped status (ENCA_nTE.ENCA_nTE = 0).

Combinations of compare/capture in ENCA_nCCR0 and ENCA_nCCR1 are listed in the table below.

Condition for Use	ENCA _n CCR0 Register	ENCA _n CCR1 Register
Only comparison is in use (encoder comparison mode).	Comparison function	Comparison function
Comparison and capture are in use (encoder capture and comparison mode)	Comparison function	Capture function
Capture and capture are in use (encoder capture mode).	Capture function	Capture function

(2) Timer Counter Startup

Writing "1" to the timer start trigger bit (ENCA_nTS.ENCA_nTS) causes setting of the timer status enable bit (ENCA_nTE.ENCA_nTE) to "1" (enables counting), and counting proceeds upon detection of a valid edge in the input signal from the encoder.

(3) Overflow Operation

An overflow occurs when up-counting is performed when the counter value is $FFFF_H$. When an overflow occurs, an overflow interrupt (INTENCAnIOV) is output, and the overflow flag (ENCAnOVF) is set to "1". The overflow flag (ENCAnOVF) is cleared to "0" when "1" is set to the overflow clear bit (ENCAnCLOV).

Operations in the generation of an overflow and clearing of the overflow flag are described below.

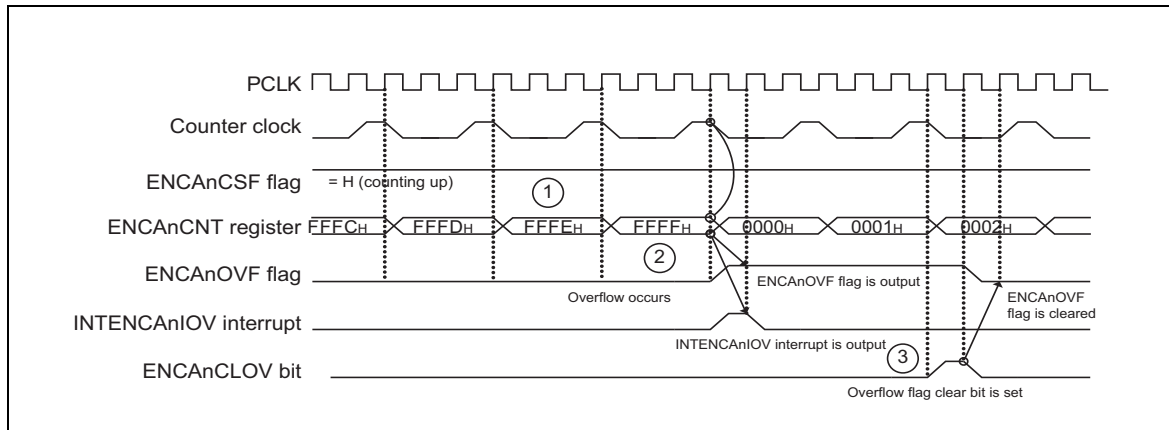

Figure 18-3 Generation of an Overflow and Settings to Clear the Overflow Flag

1. From label 1 in the figure, the counter value increases from $FFFE_H$ to $FFFH$.
2. From label 2, the counter overflows when its value changes from $FFFH$ to 0000_H . At the same time, an overflow interrupt is output and the overflow flag is set to 1.
3. Label 3 indicates the method for clearing of the overflow flag; i.e. the overflow flag is cleared to 0 by setting $ENCAncFGC.ENCAncCLOV$ to 1. Alternatively, the overflow flag may be cleared by setting $ENCAncTS.ENCAncTS$ to 1 while $ENCAncTE.ENCAncTE = 0$, or by placing the signal input as $ENCAncTSST$ (simultaneous start trigger input) at the high level.

(4) Underflow Operation

An underflow occurs when down-counting is performed when the counter value is 0000_H . When an underflow occurs, an underflow interrupt (INTENCAnIUD) is output, and the underflow flag (ENCAnUDF) is set to "1". The underflow flag (ENCAnUDF) is cleared to "0" when "1" is set to the underflow clear bit (ENCAnCLUD).

Operations in the generation of an underflow and clearing of the underflow flag are described below.

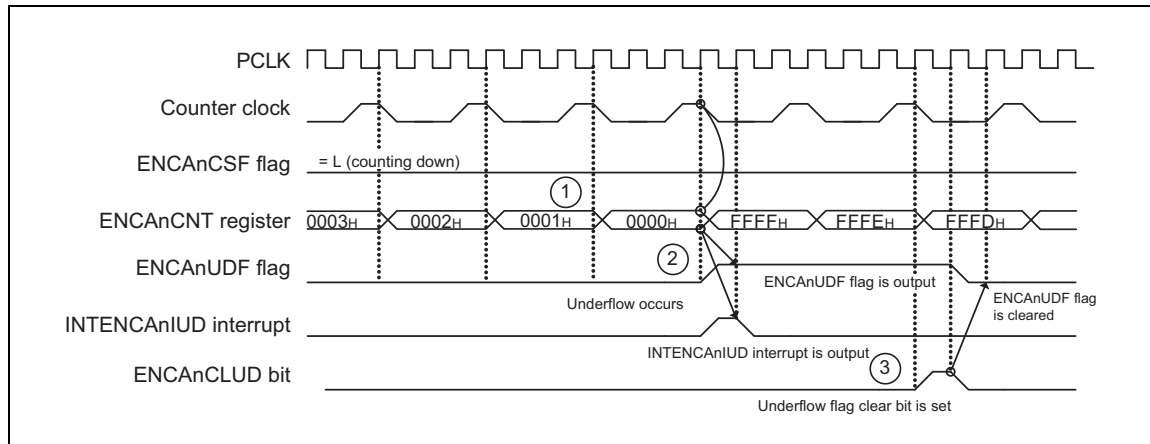

Figure 18-4 Generation of an Underflow and Settings to Clear the Underflow Flag

1. From label 1 in the figure, the counter value decreases from 0001_H to 0000_H .
2. From label 2, the counter underflows when its value changes from 0000_H to $FFFF_H$. At the same time, an underflow interrupt is output, setting the underflow flag to 1.
3. Label 3 indicates the method for clearing of the underflow flag; i.e. the underflow flag is cleared to 0 by setting ENCAncFGC.ENCAncCLUD to 1. Alternatively, the underflow flag may be cleared by setting ENCAncTS.ENCAncTS to 1 while ENCAncTE.ENCAncTE = 0, or by placing the signal input as ENCAncTSST (synchronous start trigger) at the high level.

(5) Timer Counter Stop

Writing "1" to the timer stop trigger bit (ENCAncTT.ENCAncTT) causes clearing of the timer status enable bit (ENCAncTE) to "0" and stops the counter. At this time, the timer counter is not reset to 0000_H but retains its value from before counting stopped.

18.4.2 Up/Down Control of Timer Counter

The setting of the ENCA_nCTL.ENCA_nUDS[1:0] bits and the phase of the encoder inputs (ENCA_nE0 and ENCA_nE1) control counting up and down by the timer.

(1) When ENCA_nCTL.ENCA_nUDS[1:0] = 00_B

ENCA _n UDS1	ENCA _n UDS0	Operation Description			
		Signal on the ENCA _n E0 Pin	Signal on the ENCA _n E1 Pin	Counting Operation	
0	0	Rising edge	High level	Counting down	
		Falling edge			
		Both edges			
		Rising edge	Low level		Counting up
		Falling edge			
		Both edges			

The valid edge specification for ENCA_nE0 is made by setting ENCA_nIOC1.ENCA_nEIS[1:0].

"Counting operation" indicates that counting up or down proceeds when the valid edges of the signals on ENCA_nE0 and ENCA_nE1 match.

The timing chart below shows counting operation when ENCA_nCTL.ENCA_nUDS[1:0] = 00_B.

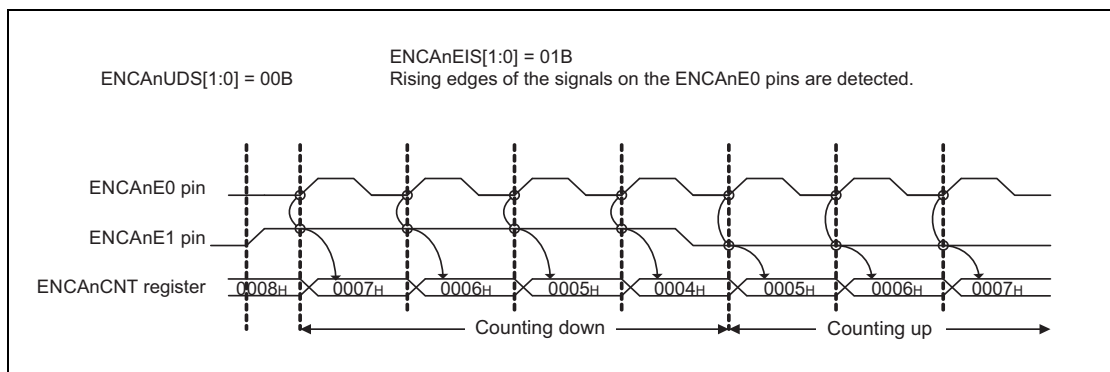

Figure 18-5 Counting Operation when ENCA_nCTL.ENCA_nUDS[1:0] = 00_B

(2) When ENCA_nCTL.ENCA_nUDS[1:0] = 01_B

ENCA _n UDS1	ENCA _n UDS0	Description of Operation					
		Signal on the ENCA _n E0 Pin	Signal on the ENCA _n E1 Pin	Counting Operation			
0	1	Low level	Rising edge	Counting down			
			Falling edge				
			Both edges				
		High level	Rising edge				
			Falling edge				
			Both edges				
		Rising edge	Low level	Both edges	Counting up		
						Falling edge	
						Both edges	
		Rising edge	High level	Both edges		Counting up	
							Falling edge
							Both edges
Simultaneous input			Retaining				

The valid edge specification for ENCA_nE0 and ENCA_nE1 is made by setting ENCA_nIOC1.ENCA_nEIS[1:0].

"Counting operation" indicates that counting up or down proceeds when the valid edges of the signals on ENCA_nE0 and ENCA_nE1 match. When valid edges coincide, the count is retained.

The timing chart below shows counting operation when ENCA_nCTL.ENCA_nUDS[1:0] = 01_B.

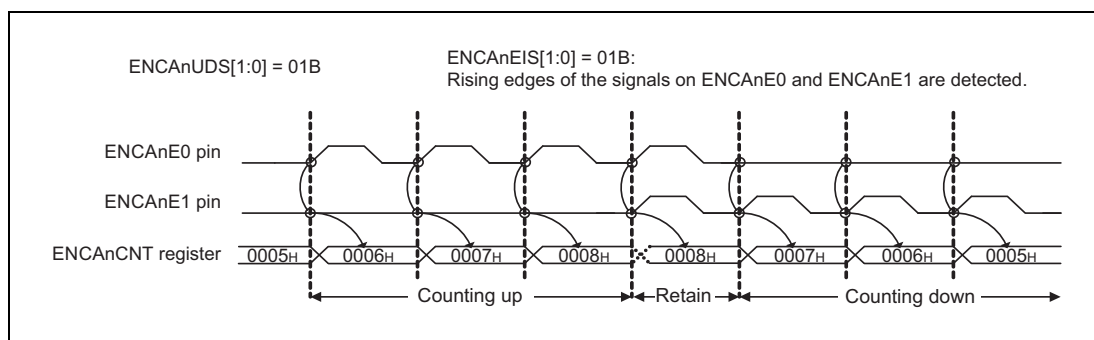

Figure 18-6 Counting Operation of ENCA_nCTL.ENCA_nUDS[1:0] = 01_B

(3) When ENCA_nCTL.ENCA_nUDS[1:0] = 10_B

ENCA _n UDS1	ENCA _n UDS0	Description of Operation		
		Signal on the ENCA _n E0 Pin	Signal on the ENCA _n E1 Pin	Counting Operation
1	0	Rising edge	Low level	Counting down
		Rising edge	Falling edge	
		Falling edge	Low level	Counting up
		Falling edge	Falling edge	
		Low level	Rising edge	Retaining
		Rising edge	Rising edge	
		High level	Rising edge	
		Falling edge	Rising edge	
		Low level	Falling edge	
		Rising edge	High level	
		High level	Falling edge	
		Falling edge	High level	

The valid edge specification for ENCA_nE0 and ENCA_nE1 (setting of ENCA_nIOC1.ENCA_nEIS[1:0] bits) is ineffective.

The timing chart below shows counting operation when ENCA_nCTL.ENCA_nUDS[1:0] = 10_B.

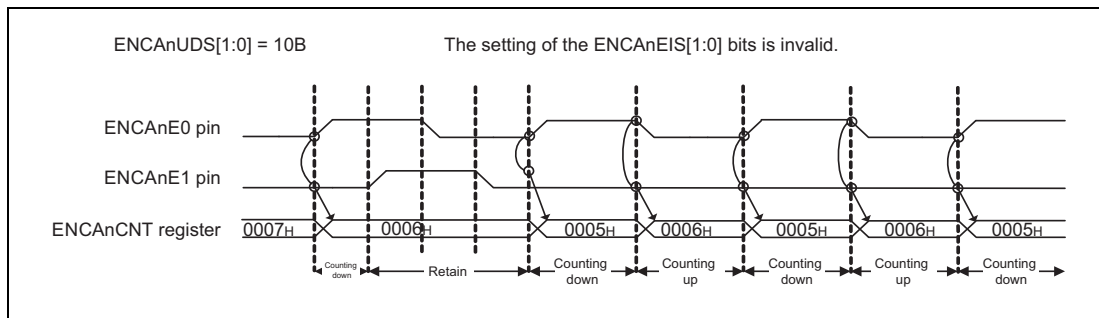

Figure 18-7 Counting Operation of ENCA_nCTL.ENCA_nUDS[1:0] = 10_B

(4) When ENCA_nCTL.ENCA_nUDS[1:0] = 11_B

ENCA _n UDS1	ENCA _n UDS0	Description of Operation		
		Signal on the ENCA _n E0 Pin	Signal on the ENCA _n E1 Pin	Counting Operation
1	1	Low level	Falling edge	Counting down
		Rising edge	Low level	
		High level	Rising edge	
		Falling edge	High level	
		Rising edge	High level	Counting up
		High level	Falling edge	
		Falling edge	Low level	
		Low level	Rising edge	
		Simultaneous input		

The valid edge specification for ENCA_nE0 and ENCA_nE1 (setting of ENCA_nIOC1.ENCA_nEIS[1:0] bits) is ineffective.

When the valid edges of the signals on ENCA_nE0 and ENCA_nE1 coincide, the count is retained.

The timing chart below shows counting operation when ENCA_nCTL.ENCA_nUDS[1:0] = 11_B.

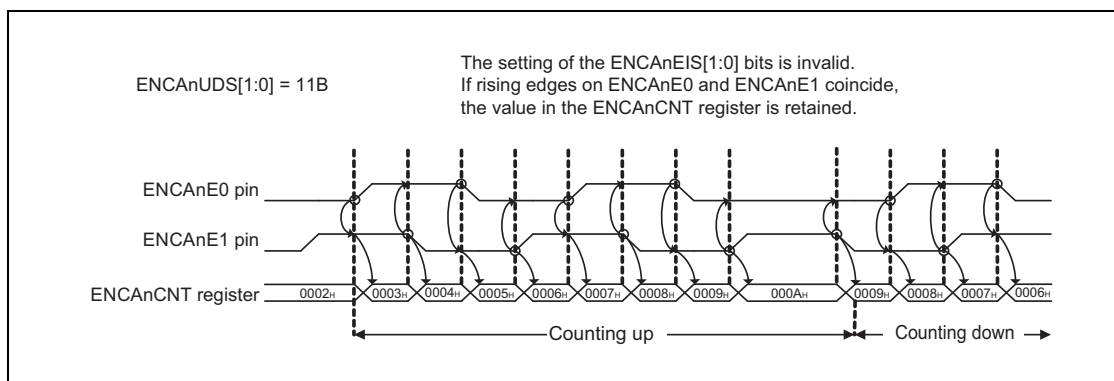

Figure 18-8 Counting Operation of ENCA_nCTL.ENCA_nUDS[1:0] = 11_B

18.4.3 Control of Timer Counter Clearing

Any of following condition leads to clearing of the timer counter.

Clearing condition (1): Detection of a valid edge of the encoder clearing input signal (signal on the ENCA_nEC pin)

Clearing condition (2): Level detection of the encoder input and encoder clearing input signals (signals on the ENCA_nE0, ENCA_nE1, and ENCA_nEC pins)

Select clearing condition by settings of the ENCA_nSCE, ENCA_nZCL, ENCA_nBCL, ENCA_nACL, ENCA_nECS1 and ENCA_nECS0 bits in the ENCA_nIOC1 register.

Condition for Clearing	ENCA _n SCE	ENCA _n ZCL	ENCA _n BCL	ENCA _n ACL	ENCA _n ECS1, ENCA _n ECS0
(1)	0	Invalid	Invalid	Invalid	Valid
(2)	1	Valid	Valid	Valid	Invalid

(1)-1 Clearing on Detection of a Valid Edge of the Encoder-Clearing Input Signal (when ENCA_nIOC1.ENCA_nSCE = 0).

- Upon detection of the valid edge of ENCA_nEC, the timer counter is cleared to 0000_H in synchronization with the operation clock.
- The valid edge of ENCA_nEC is specified by the setting of the ENCA_nECS1 and ENCA_nECS0 bits in the ENCA_nIOC1 register.
- The settings of the ENCA_nZCL, ENCA_nBCL, and ENCA_nACL bits in the ENCA_nIOC1 register are ineffective.
- A clear interrupt signal (INTENCA_nIEC) is output simultaneously with timer counter clearing.

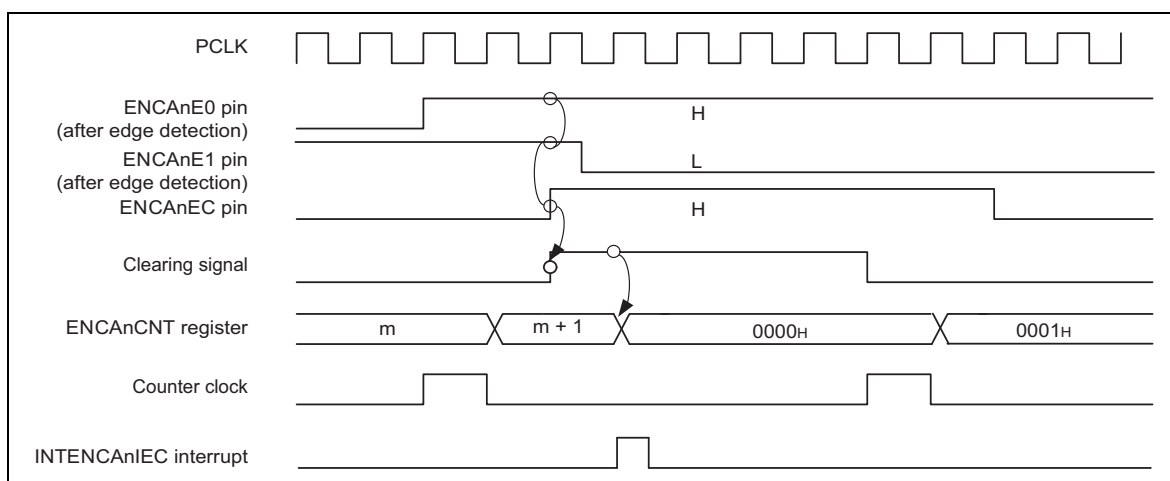

Figure 18-9 Operations to Clear the Counter in Response to Encoder Clearing Input (ENCA_nEC)

(1)-2 Operations for Counter Clearing and Capture in Response to Encoder Clearing Input (ENCA_nEC)

Figure 18-10 Timing of Counter Clearing and Capture Operations in Response to Encoder Clearing Input (ENCA_nEC)

<Setting condition>

ENCA_nCTL.ENCA_nCRM1 = 1: selects the ENCA_nCCR1 register for capture register.

ENCA_nCTL.ENCA_nCTS = 1: selects the ENCA_nEC pin input as capture trigger input.

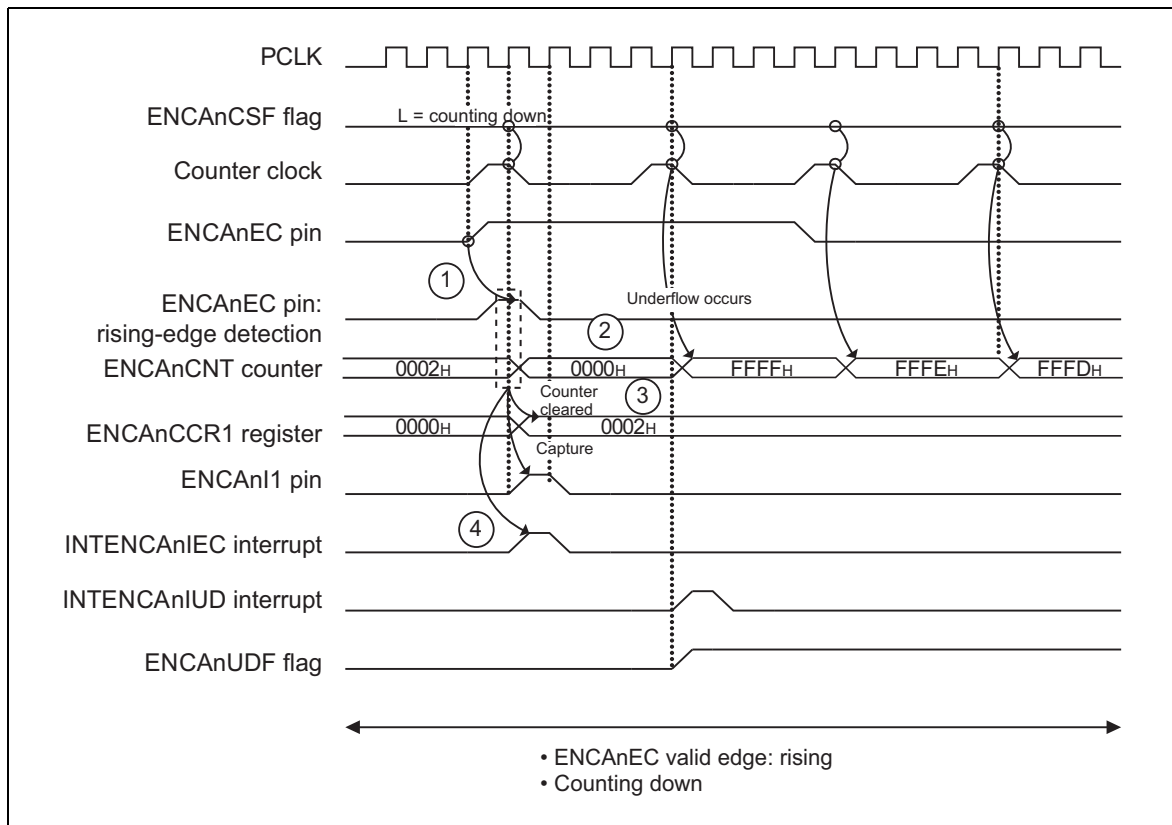
ENCA_nIOC1.ENCA_nECS[1:0] = 01B: selects detection of the rising edge on the ENCA_nEC pin input detection as the counter clear condition

1. Capture proceeds on the rising edge of the trigger signal input on the ENCA_nEC pin.
2. Clearing of the counter's value to 0000_H in response to the input on the ENCA_nEC pin proceeds.
3. The pre-clearing value from the counter (0002_H) is captured in the ENCA_nCCR1 register on the rising edge of the input signal on the ENCA_nEC pin.
4. The cleared interrupt (INTENCA_nIEC) and capture interrupt (INTENCA_nI1) in response to the input signal on the ENCA_nEC pin are output at the same time.

(2) Clearing in Response to Detection of the Input and Clearing Input Signals from the Encoder

Clearing is in accord with the settings of the ENCA_nSCE, ENCA_nZCL, ENCA_nBCL, ENCA_nACL, ENCA_nECS1 and ENCA_nECS0 bits in the ENCA_nIOC1 register (when ENCA_nIOC1.ENCA_nSCE = 1).

- Clearing levels on the ENCA_nEC, ENCA_nE1, and ENCA_nE0 pins as specified by the settings of the ENCA_nZCL, ENCA_nBCL, and ENCA_nACL bits in the ENCA_nIOC1 register are detected and the timer counter is cleared to 0000_H in synchronization with the operating clock.
- The setting of the ENCA_nIOC1.ENCA_nECS[1:0] bits is ineffective.
- The encoder cleared interrupt signal (INTENCA_nIEC) is output simultaneously with the timer counter clearing.

Conditions for clearing of the timer counter in accord with the setting of the ENCA_nZCL, ENCA_nBCL and ENCA_nACL bits in the ENCA_nIOC1 register are given in the table below.

Counter Clearing Condition Settings			Level Input on the Encoder Pin		
ENCA _n ZCL	ENCA _n BCL	ENCA _n ACL	ENCA _n EC	ENCA _n E1	ENCA _n E0
0	0	0	Low	Low	Low
0	0	1	Low	Low	High
0	1	0	Low	High	Low
0	1	1	Low	High	High
1	0	0	High	Low	Low
1	0	1	High	Low	High
1	1	0	High	High	Low
1	1	1	High	High	High

(a) When Input on the ENCA_nEC Pin Follows Input on the ENCA_nE1 Pin during Counting up (When ENCA_nIOC1.ENCA_nACL = 1, ENCA_nIOC1.ENCA_nBCL = 0, ENCA_nIOC1.ENCA_nZCL = 1, and ENCA_nCTL.ENCA_nUDS[1:0] = 11_B)

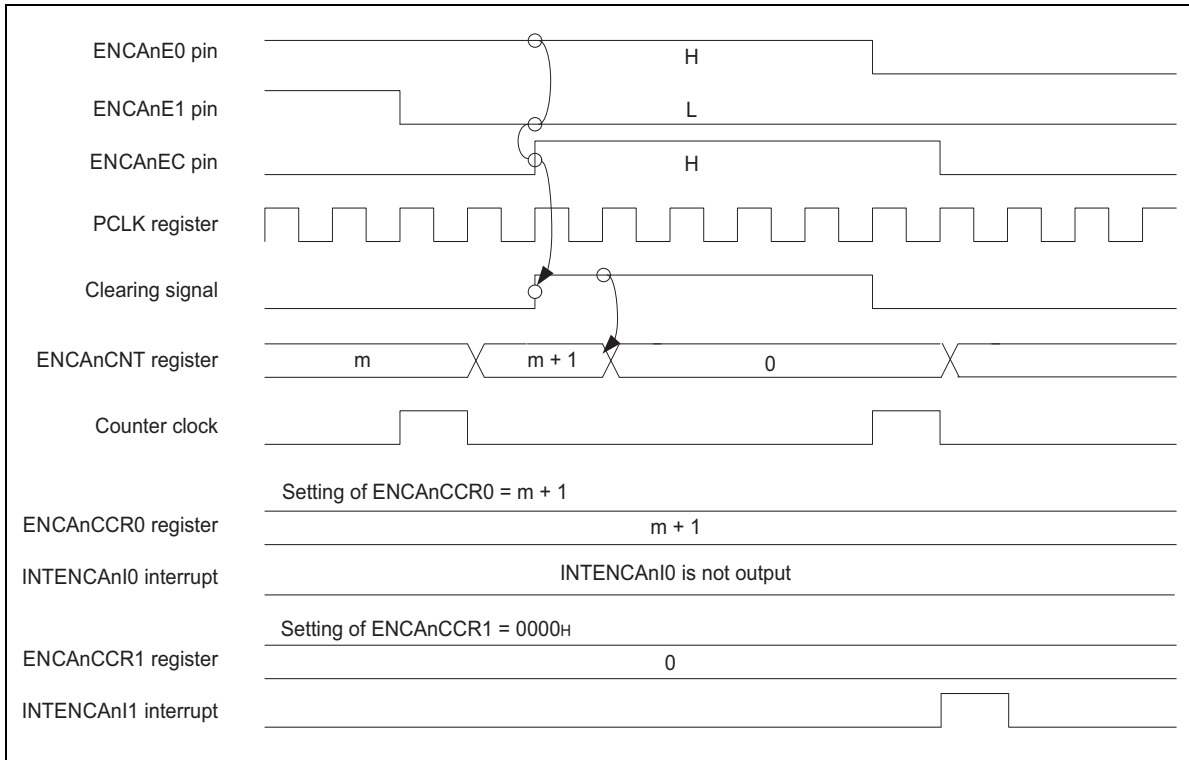

Figure 18-11 Timing of Clearing when Input on the ENCA_nEC Pin Follows Input on the ENCA_nE1 Pin during Counting up

- (b) When the Timing of Input on the ENCA_nEC and ENCA_nE1 Pins Coincides during Counting up (When ENCA_nIOC1.ENCA_nACL = 1, ENCA_nIOC1.ENCA_nBCL = 0, ENCA_nIOC1.ENCA_nZCL = 1, and ENCA_nCTL.ENCA_nUDS[1:0] = 11_B)

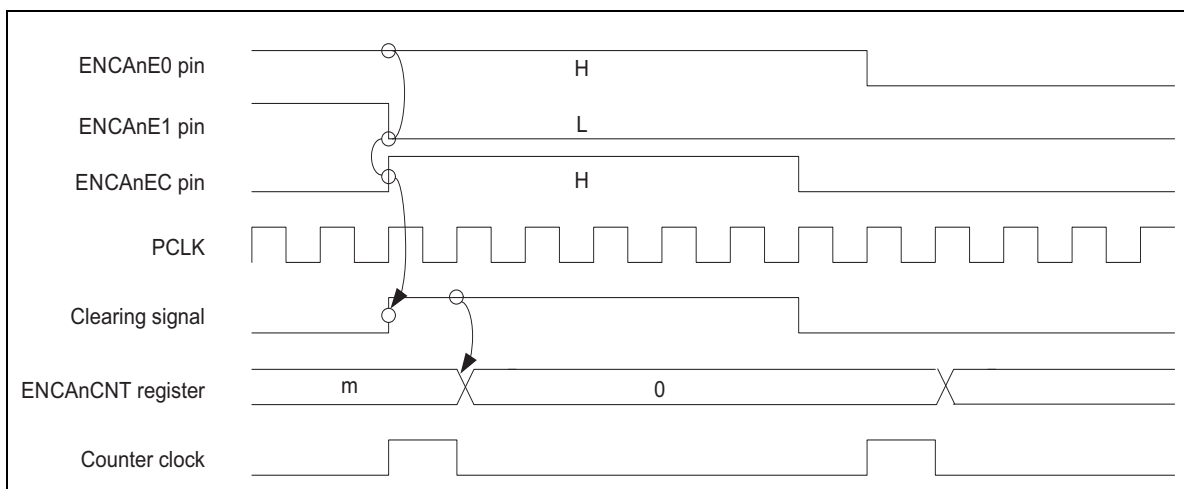

Figure 18-12 Timing of Clearing when Input on the ENCA_nEC and ENCA_nE1 Pins Coincides during Counting up

- (c) When Input on the ENCA_nEC Pin Precedes Input on the ENCA_nE1 Pin during Counting up (When ENCA_nIOC1.ENCA_nACL = 1, ENCA_nIOC1.ENCA_nBCL = 0, ENCA_nIOC1.ENCA_nZCL = 1, and ENCA_nCTL.ENCA_nUDS[1:0] = 11_B)

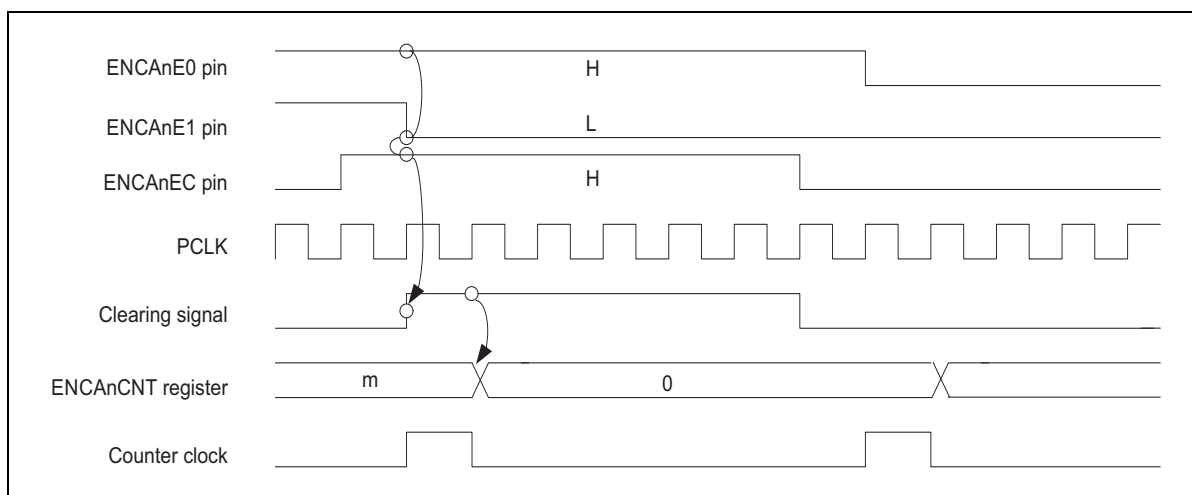

Figure 18-13 Timing of Clearing when Input on the ENCA_nEC Pin Precedes Input on the ENCA_nE1 Pin during Counting up

(d) When Input on the ENCA_nEC Pin Follows Input on the ENCA_nE1 Pin during Counting down (When ENCA_nIOC1.ENCA_nACL = 1, ENCA_nIOC1.ENCA_nBCL = 0, ENCA_nIOC1.ENCA_nZCL = 1, and ENCA_nCTL.ENCA_nUDS[1:0] = 11_B)

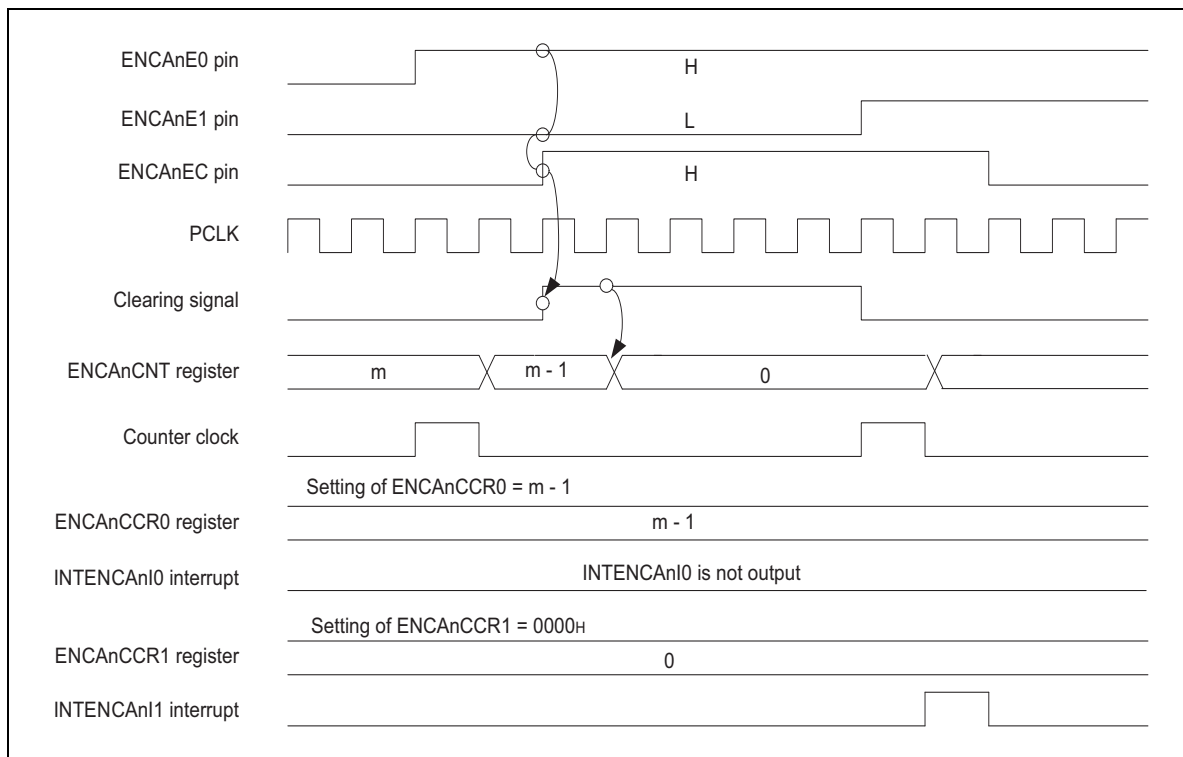

Figure 18-14 Timing of Clearing when Input on the ENCA_nEC Pin Follows Input on the ENCA_nE1 Pin during Counting down

18.4.4 Detailed Description of the ENCA_nCCR0 Register

(1) Compare Function

- When ENCA_nCTL.ENCA_nCRM0 = 0, the ENCA_nCCR0 register functions as a dedicated comparison register.
- A compare 0 match interrupt (INTENCA_nI0) is output when the values in the timer counter and the ENCA_nCCR0 register match.
- When ENCA_nCTL.ENCA_nECM0 = 1, the timer counter is cleared to 0000_H in synchronization with the operating clock (PCLK) upon a compare match if further counting is to be counting up.

ENCA _n CCR0 Function	Compare Match Clear Control	Next Counting Operation	Timer Counter Clearing Upon Compare Match with ENCA _n CCR0
ENCA _n CRM0	ENCA _n ECM0		
0 (Compare)	0	Counting up	Does not clear timer counter (continues counting operation).
		Counting down	
	1	Counting up	Clears timer counter to 0000 _H .
		Counting down	Does not clear timer counter (continues counting operation).

- When ENCA_nCTL.ENCA_nLDE = 1**
- Upon occurrence of an underflow, the setting value of the ENCA_nCCR0 register is loaded to the timer counter.
 - An underflow interrupt (INTENCA_nIUD) is output.

(2) Capture Function

- When ENCA_nCTL.ENCA_nCRM0 = 1, the ENCA_nCCR0 register functions as a dedicated capture register.
- On detection of the valid edge of capture trigger input 0 (ENCA_nI0), the value of the timer counter is stored in the ENCA_nCCR0 register.
- A capture 0 interrupt (INTENCA_nI0) is output during a capture operation.

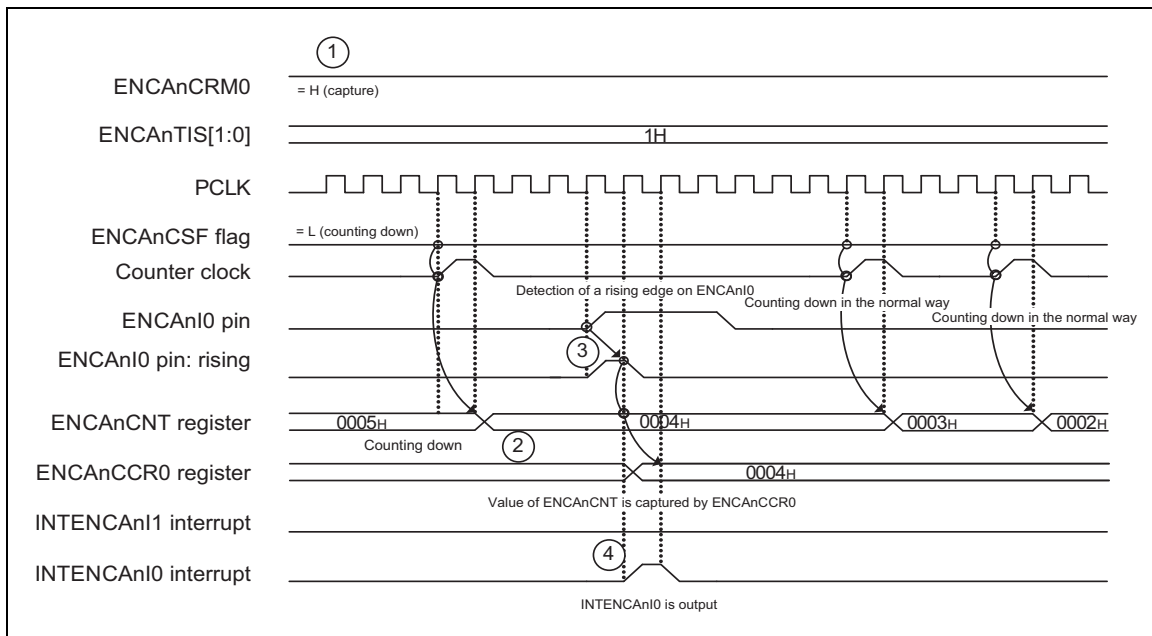

Figure 18-15 Capture Operation between Pulses of the Counter Clock (ENCA_nCCR0)

1. The following values are set at label 1: ENCA_nCRM0 = 1, ENCA_nTIS1 and ENCA_nTIS0 = 01_B.
2. Counting down proceeds at label 2.
3. At label 3, a rising edge of the input signal on the ENCA_nI0 pin is detected, and the value reached by the counter is captured in the ENCA_nCCR0 register.
4. At label 4, the interrupt signal (INTENCA_nI0) that corresponds to capture to the ENCA_nCCR0 register is output.

18.4.5 Detailed Description of the ENCA_nCCR1 Register

(1) Compare Function

- When ENCA_nCTL.ENCA_nCRM1 = 0, the ENCA_nCCR1 register functions as a dedicated comparison register.
- A compare 1 match interrupt (INTENCA_nI1) is output when the values in the timer counter and the ENCA_nCCR1 register match.
- When ENCA_nCTL.ENCA_nECM1 = 1, the timer counter is cleared to 0000_H in synchronization with the operating clock (PCLK) upon a compare match if further counting is to be counting down.

ENCA _n CCR1 Function	Compare Match Clear Control	Next Counting Operation	Timer Counter Clearing upon Compare Match with ENCA _n CCR1
ENCA _n CRM1	ENCA _n ECM1		
0 (Compare)	0	Counting up	Does not clear timer counter (continues count operation).
		Counting down	
	1	Counting up	Does not clear timer counter (continues count operation).
		Counting down	Clears timer counter to 0000 _H .

Compare match interrupt detection mask function

- When ENCA_nCTL.ENCA_nCME = 1, masking of compare 1 match interrupt detection is enabled. In this state, the compare 1 match interrupt is output upon the first match of the value of the timer counter and the ENCA_nCCR1 setting value, and interrupts are then masked for the second and subsequent compare matches.
- When ENCA_nCTL.ENCA_nMCS = 0, writing to the ENCA_nCCR1 register disables masking of compare 1 match interrupt detection.
- When ENCA_nCTL.ENCA_nMCS = 1, clearing of the timer counter due to input on the ENCA_nEC pin or a match between the value in the ENCA_nCCR0 register and the timer counter disables masking of compare 1 match interrupt detection.
- When ENCA_nCTL.ENCA_nMCS = 1 and ENCA_nCTL.ENCA_nLDE = 1, loading of the value from the ENCA_nCCR0 register to the timer counter upon detection of an underflow disables masking of compare 1 match interrupt detection.
- Setting ENCA_nCTL.ENCA_nECM1 = 1 is prohibited while compare 1 match interrupt detection masking is enabled.

ENCA _n CCR1 Function	Compare 1 Match Interrupt Masking	Interrupt Mask Cancel Trigger		Compare 1 Match Interrupt Output upon Compare Match with ENCA _n CCR1
ENCA _n CRM1	ENCA _n CME	ENCA _n MCS	Underflow Occurrence upon ENCA _n LDE = 0	
0 (Compare)	0 (Masking disabled)	— (Setting invalid)	—	Outputs compare 1 match interrupt upon each compare match.
	1 (Masking enabled)	0 (Writing to ENCA _n CCR1)	1 (Timer counter clearing)	Occurred (Loading of ENCA _n CCR0 to timer counter)

(2) Capture Function

- When ENCA_nCTL.ENCA_nCRM1 = 1, the ENCA_nCCR1 register functions as a dedicated capture register.

The capture operation to ENCA_nCCR1 is shown in the timing chart in Section 18.6, (4) Timing of Basic Encoder Operation 4 (Encoder Capture Mode).

Operations corresponding to the settings of ENCA_nCTL.ENCA_nCTS are listed in the table below.

ENCA _n CCR1 Function	Capture Trigger Selection	Capture Trigger Signal	Timer Counter Clearing	Interrupt Occurrence
ENCA _n CRM1	ENCA _n CTS			
1 (Capture)	0	Capture trigger 1 input (ENCA _n I1 pin)	Does not clear timer counter.	(1) Capture 1 interrupt (INTENCA _n I1)
	1	Encoder clearing input (ENCA _n EC pin)	Clears timer counter.	(1) Capture 1 interrupt (INTENCA _n I1) (2) Encoder clear interrupt (INTENCA _n IEC)

The basic operations of the capture function are described below.

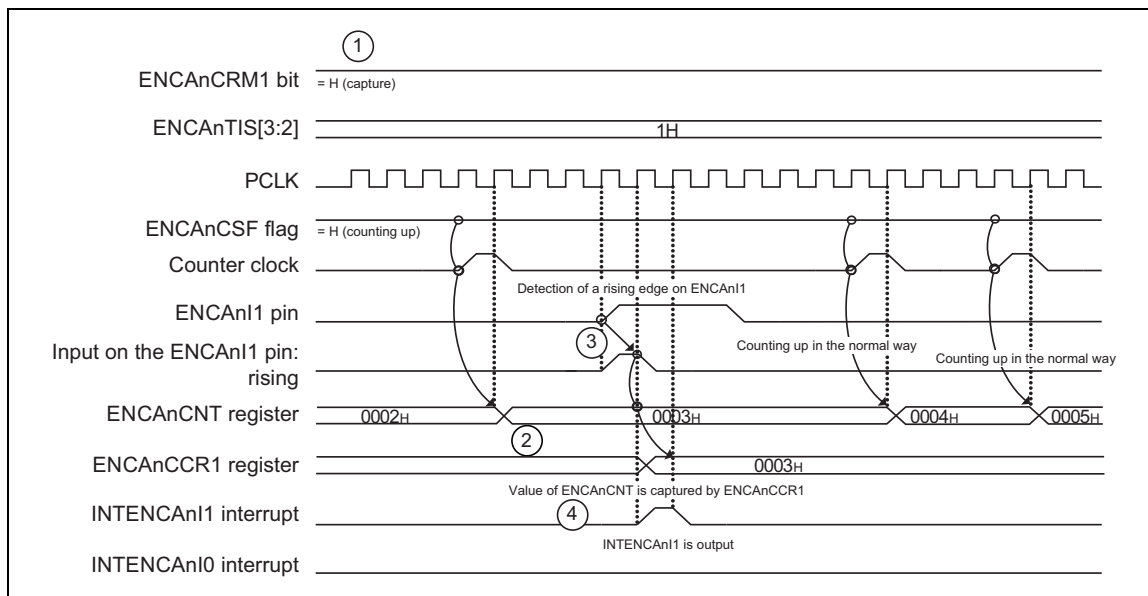

Figure 18-16 Capture between Pulses of the Counter Clock (ENCAAnCCR1)

1. The following values are set at label 1: ENCAAnCRM1 = 1, ENCAAnTIS3 and ENCAAnTIS2 = 01_B.
2. Counting up proceeds at label 2.
3. At label 3, a rising edge of the input signal on the ENCAAn1 pin is detected, and the value reached by the counter is captured in the ENCAAnCCR1 register.
4. At label 4, the interrupt signal (INTENCAAn1) that corresponds to capture to the ENCAAnCCR1 register is output.

(3) Timer Counter Clearing upon Comparison Register Match

Clearing of the timer counter upon a match between its value and the setting of ENCA_nCCR0/1, in accord with the settings of the ENCA_nECM1 and ENCA_nECM0 bits in the ENCA_nCTL register, is detailed in the following table.

ENCA _n ECM1 and ENCA _n ECM0	Next Counting Operation	Timer Counter Clearing upon Compare Match with ENCA _n CCR1	Timer Counter Clearing upon Compare Match with ENCA _n CCR0
00	Counting up	Does not clear timer counter (continues counting operation).	Does not clear timer counter (continues counting operation).
	Counting down	Does not clear timer counter (continues counting operation).	Does not clear timer counter (continues counting operation).
01	Counting up	Does not clear timer counter (continues counting operation).	Clears timer counter to 0000 _H .
	Counting down	Does not clear timer counter (continues counting operation).	Does not clear timer counter (continues counting operation).
10	Counting up	Does not clear timer counter (continues counting operation).	Does not clear timer counter (continues counting operation).
	Counting down	Clears timer counter to 0000 _H .	Does not clear timer counter (continues counting operation).
11	Counting up	Does not clear timer counter (continues counting operation).	Clears timer counter to 0000 _H .
	Counting down	Clears timer counter to 0000 _H .	Does not clear timer counter (continues counting operation).

18.4.6 Timer Counter Operation Start/Stop

(1) Starting the Timer in a Single Encoder-Timer Configuration

Operation can be started by setting `ENCAnTE.ENCAnTS = 1`.

(2) Stopping an Encoder Timer

The timer is stopped by setting `ENCAnTT.ENCAnTT = 1` and `ENCAnTE.ENCAnTE = 0`.

In a single encoder-timer configuration, setting the `ENCAnTT.ENCAnTT` bit to 1 changes the value of the `ENCAnTE` bit to 0 and thus stops the timer.

18.5 Setting Sequences

18.5.1 Encoder Timer Setting Procedure

The encoder timer setting procedure is described below.

	Action	State of Setting
Initial setting	Reset release	Power-on state, encoder-timer operation stopped state (writing to the individual registers is possible)
Initial settings of encoder timer	Perform the following initial settings. <ul style="list-style-type: none"> Setting for counter Setting for clearing counter Setting for ENCA_nCCR0 register Setting for ENCA_nCCR1 register 	Counting operations are stopped in this state. The value of the ENCA _n TE bit indicating the state of operation is 0.
	Perform the initial settings for counter. <ul style="list-style-type: none"> Set any 16-bit value to ENCA_nCNT register. (When, after setting this register, the ENCA_nTS bit is set to "1", the counter operation starts from the set count value.) 	The set value is set as the initial value of the counter register.
Operation start	Perform the counter operation start setting. <ul style="list-style-type: none"> Set the ENCA_nTS bit to "1". 	Counting is started in this state. The value of the ENCA _n TE bit indicating the state of operation is 1, and the counter clock is supplied to the internal circuit.
Operating	Only those registers whose setting can be changed during operation can be rewritten. <ul style="list-style-type: none"> ENCA_nCCR0 register setting ENCA_nCCR1 register setting ENCA_nIOC0 register setting 	Count proceeds from the initial setting, and is up or down in accord with the setting of the ENCA _n E0 and ENCA _n E1 pins.
Operation stop	Perform the counter operation stop setting during operation. <ul style="list-style-type: none"> Set the ENCA_nTT bit to "1". 	Counting operations are stopped in this state. The value of the ENCA _n TE bit indicating the state of operation is 0.
Encoder timer stop	Reset	The setting registers are initialized.

(1) Initial Settings for Counter

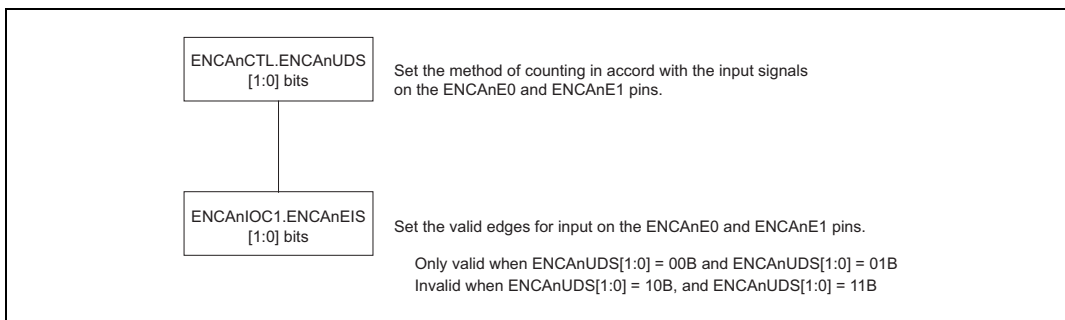

(2) Initial Settings for Counter Clearing

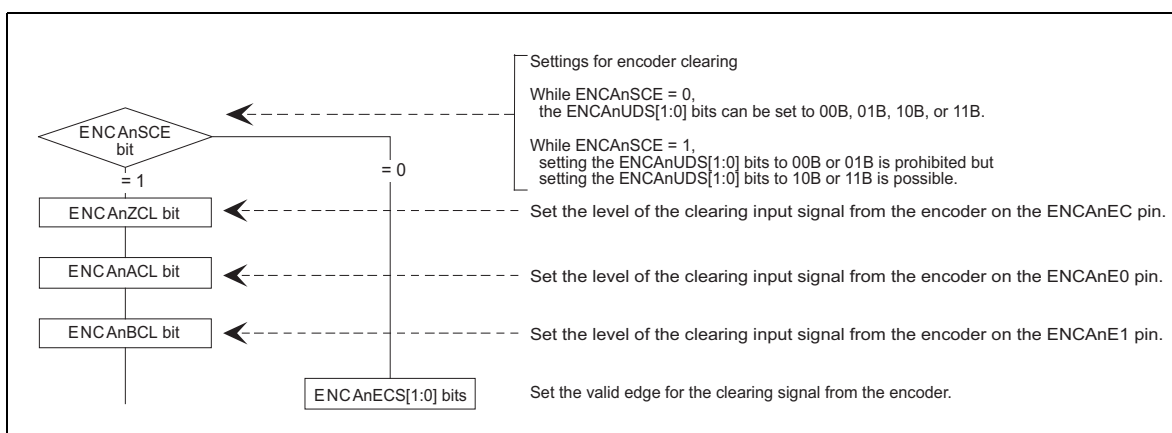

(3) Initial Settings for the ENCAAnCCR0 Register

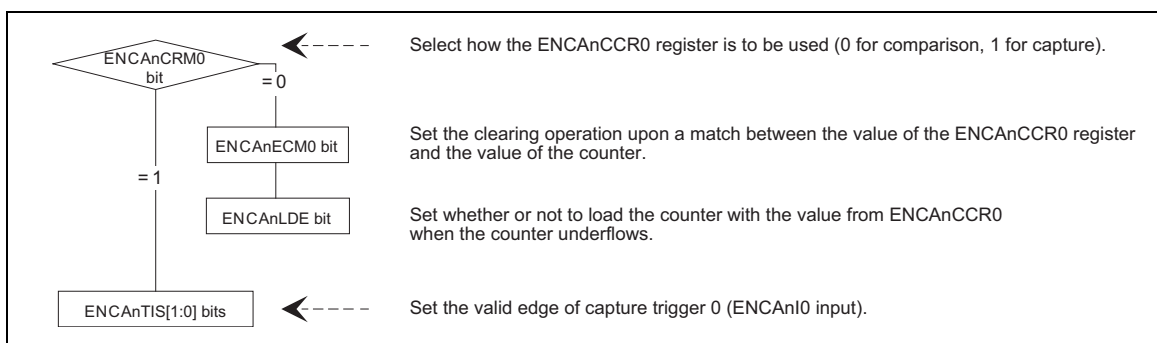

(4) Settings for the ENCA_nCCR1 Register

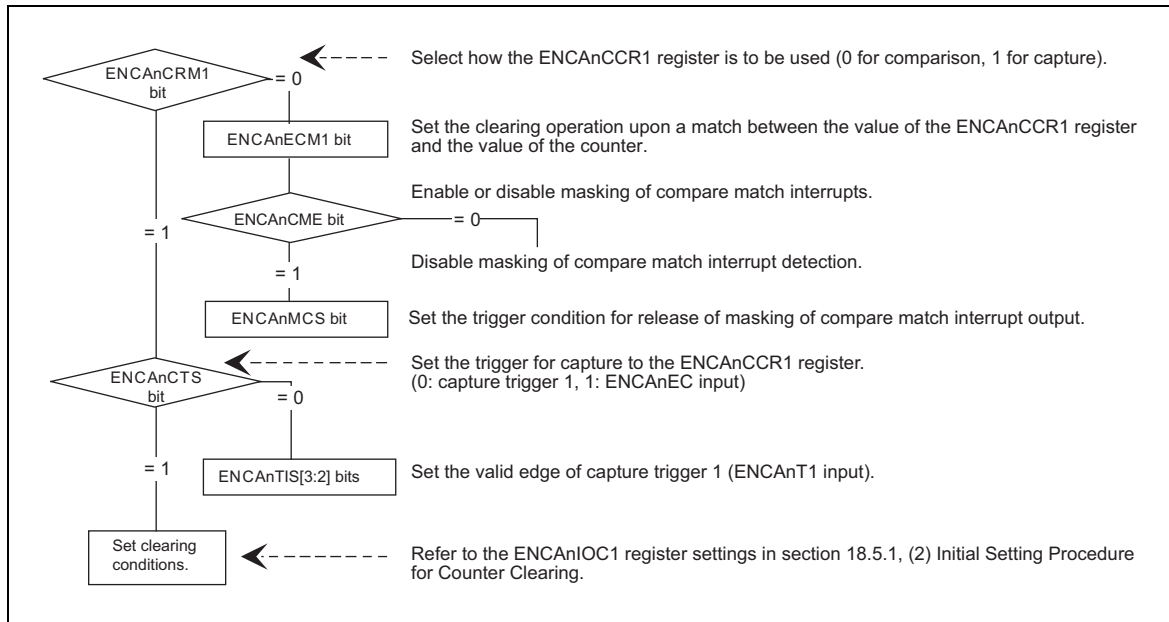

18.6 Timing Charts for Encoder Operations

(1) Timing of Basic Encoder Operation 1 (Encoder Comparison Mode 1)

<Setting condition>

- ENCA_nCTL.ENCA_nCRM[1:0] = 00_B:
Comparison is selected as the function of the ENCA_nCCR0 and ENCA_nCCR1 registers.
- ENCA_nCTL.ENCA_nECM[1:0] = 01_B:
If counting after a match between the values in the counter and the ENCA_nCCR0 register is upwards, the counter is cleared.
- ENCA_nCTL.ENCA_nLDE = 1:
When the counter underflows, it is loaded with the value from the ENCA_nCCR0 register.

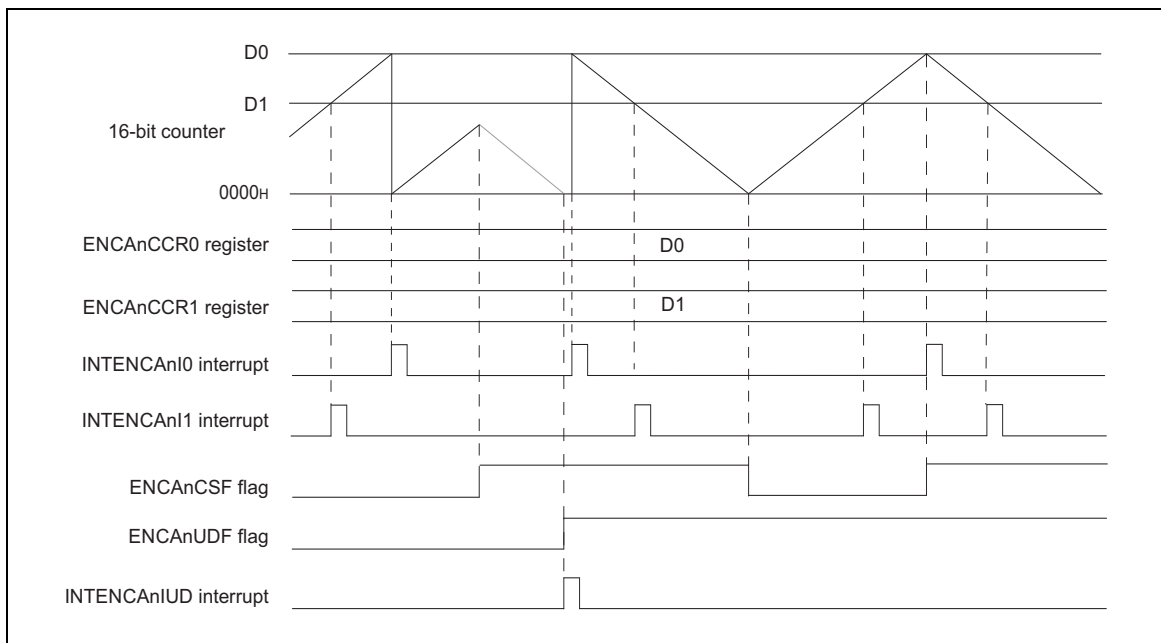

Figure 18-17 Timing of Basic Encoder Operation 1 (Encoder Comparison Mode 1)

A compare match interrupt (INTENCA_nI0) is generated when the values of the counter and register ENCA_nCCR0 (D0) match.
If further counting is upwards, the counter is cleared to 0000_H because ENCA_nECM0 = 1.

A compare match interrupt (INTENCA_nI1) is generated when the values of the counter and register ENCA_nCCR1 (D1) match.
Counter clearing due to a match with ENCA_nCCR1 does not proceed because ENCA_nECM1 = 0.

An underflow interrupt (INTENCA_nIUD) is generated when the counter underflows.
ENCA_nLDE = 1, so the counter is loaded with the value from the ENCA_nCCR0 register (D0) when the counter underflows.

ENCA_nLDE = 1 and ENCA_nECM[1:0] = 01_B, so counting is from 0000_H to the setting of the ENCA_nCCR0 register.

(2) Timing of Basic Encoder Operation 2 (Encoder Comparison Mode 2)

<Setting condition>

- ENCA_nCTL.ENCA_nCRM[1:0] = 00_B:
Comparison is selected as the function of the ENCA_nCCR0 and ENCA_nCCR1 registers.
- ENCA_nCTL.ENCA_nECM[1:0] = 00_B:
The counter is not cleared on a match between its value and that of the ENCA_nCCR0 register.
- ENCA_nCTL.ENCA_nLDE = 0:
The counter is not loaded with the value from the ENCA_nCCR0 register.

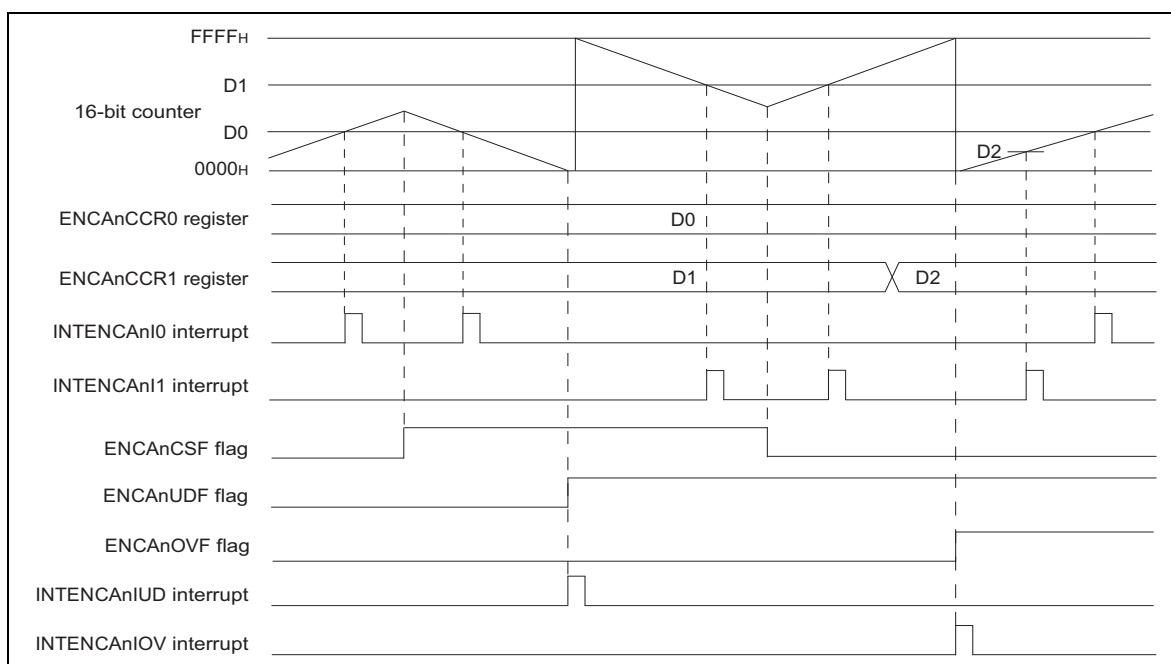

Figure 18-18 Timing of Basic Encoder Operation 2 (Encoder Comparison Mode 2)

A compare match interrupt (INTENCA_nI0) is generated when the values of the counter and register ENCA_nCCR0 (D0) match. Counter clearing due to matching with ENCA_nCCR0 does not proceed because ENCA_nECM0 = 0.

A compare match interrupt (INTENCA_nI1) is generated when the values of the counter and register ENCA_nCCR1 (D1 and D2) match. Counter clearing due to matching with ENCA_nCCR1 does not proceed because ENCA_nECM1 = 0.

Overflow interrupts (INTENCA_nIOV) or underflow interrupts (INTENCA_nIUD) are generated in response to overflows or underflows of the counter.

(3) Timing of Basic Encoder Operation 3 (Encoder Comparison Mode 3)

<Setting condition>

- ENCA_nCTL.ENCA_nCRM[1:0] = 00_B:
Comparison is selected as the function of the ENCA_nCCR0 and ENCA_nCCR1 registers.
- ENCA_nCTL.ENCA_nECM[1:0] = 11_B:
If counting after a match between the values in the counter and the ENCA_nCCR0 register is upwards, the counter is cleared.
If further counting after a match between the values in the counter and the ENCA_nCCR1 register is downwards, the counter is cleared.
- ENCA_nCTL.ENCA_nLDE = 0
The counter is not loaded with the value from the ENCA_nCCR0 register.

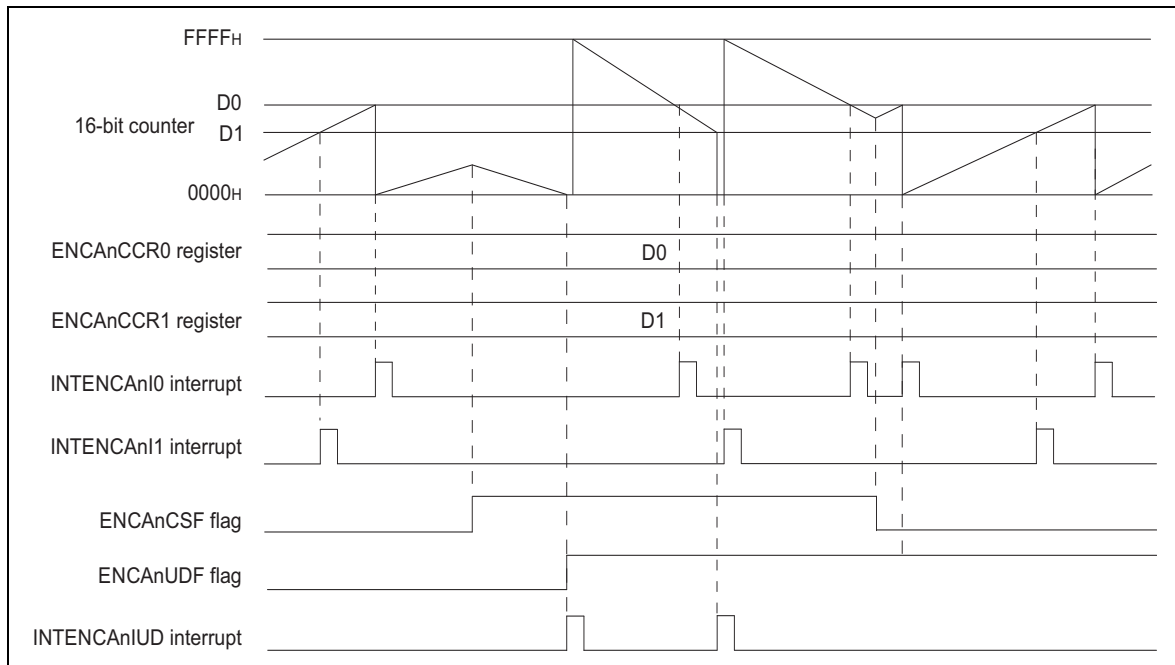

Figure 18-19 Timing of Basic Encoder Operation 3 (Encoder Comparison Mode 3)

A compare match interrupt (INTENCA_nI0) is generated when the values of the counter and register ENCA_nCCR0 (D0) match.

If further counting is upwards, the counter is cleared to 0000_H because ENCA_nECM0 = 1.

A compare match interrupt (INTENCA_nI1) is generated when the values of the counter and register ENCA_nCCR1 (D1) match.

If further counting is downwards, the counter is cleared to 0000_H because ENCA_nECM1 = 1.

(4) Timing of Basic Encoder Operation 4 (Encoder Capture Mode)

<Setting condition>

- ENCA_nCTL.ENCA_nCRM[1:0] = 11_B:
Capture is selected as the function of the ENCA_nCCR0 and ENCA_nCCR1 registers.
- ENCA_nCTL.ENCA_nECM[1:0] = 00_B:
The counter is not cleared on a match between its value and that of the ENCA_nCCR0 register.
- ENCA_nCTL.ENCA_nLDE = 0:
The setting from the ENCA_nCCR0 register is not loaded to the counter.
- ENCA_nIOC1.ENCA_nSCE = 0, ENCA_nECS[1:0] = 00_B:
Input on the ENCA_nEC pin does not lead to edge detection.
- ENCA_nIOC0.ENCA_nTIS[3:2] = 01_B:
Selects detection of rising edges of the signal on the ENCA_nI1 pin.
- ENCA_nIOC0.ENCA_nTIS[1:0] = 01_B:
Selects detection of rising edges of the signal on the ENCA_nI0 pin.

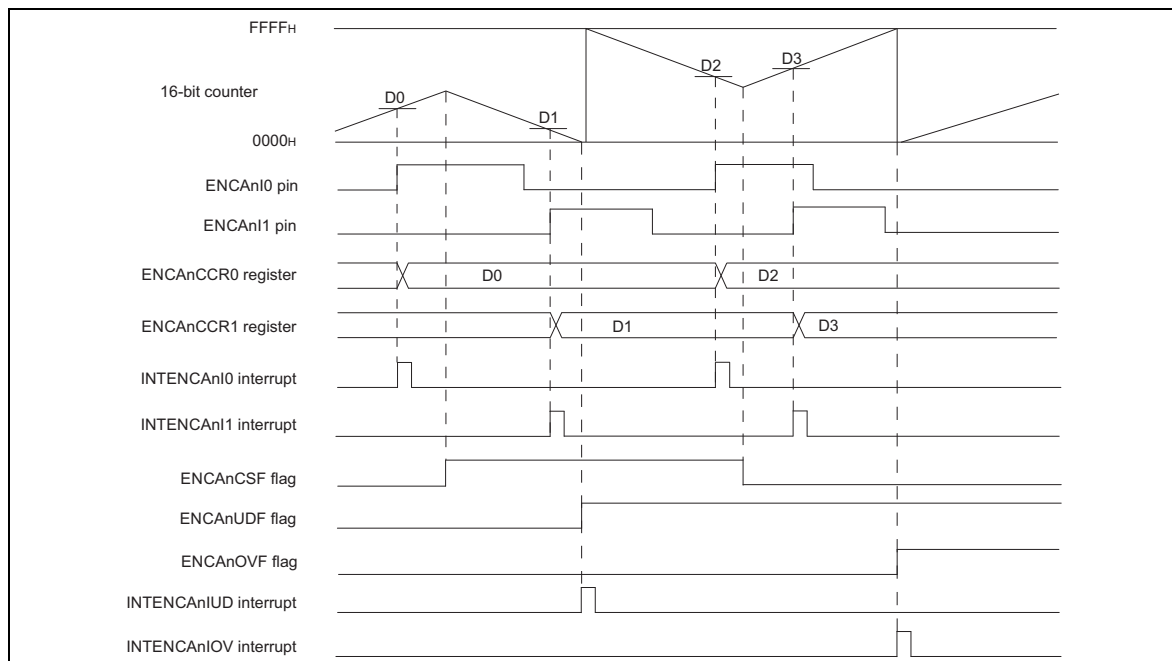

Figure 18-20 Timing of Basic Encoder Operation 4 (Encoder Capture Mode)

The detection of a rising edge on the ENCA_nI0 pin leads to storage of the counter value in the capture register (ENCA_nCCR0) and the generation of a capture interrupt (INTENCA_nI0).

The detection of a rising edge on the ENCA_nI1 pin leads to storage of the counter value in the capture register (ENCA_nCCR1) and the generation of a capture interrupt (INTENCA_nI1).

Overflow interrupts (INTENCA_nIOV) or underflow interrupts (INTENCA_nIUD) are generated in response to overflows or underflows of the counter.

**(5) Timing of Basic Encoder Operation 5
(Encoder Capture and Comparison Mode)**

<Setting condition>

- ENCA_nCTL.ENCA_nCRM[1:0] = 10_B:
Select the comparison function for the ENCA_nCCR0 register and the capture function for the ENCA_nCCR1 register.
- ENCA_nCTL.ENCA_nECM[1:0] = 01_B:
The counter is cleared when its value matches that of the ENCA_nCCR0 register.
- ENCA_nCTL.ENCA_nLDE = 1:
When the counter underflows, it is loaded with the value from the ENCA_nCCR0 register.
- ENCA_nIOC1.ENCA_nSCE = 0, ENCA_nECS[1:0] = 00_B
- ENCA_nIOC0.ENCA_nTIS[3:2] = 11_B
Selects detection of both edges of the signal on the ENCA_nI1 pin.

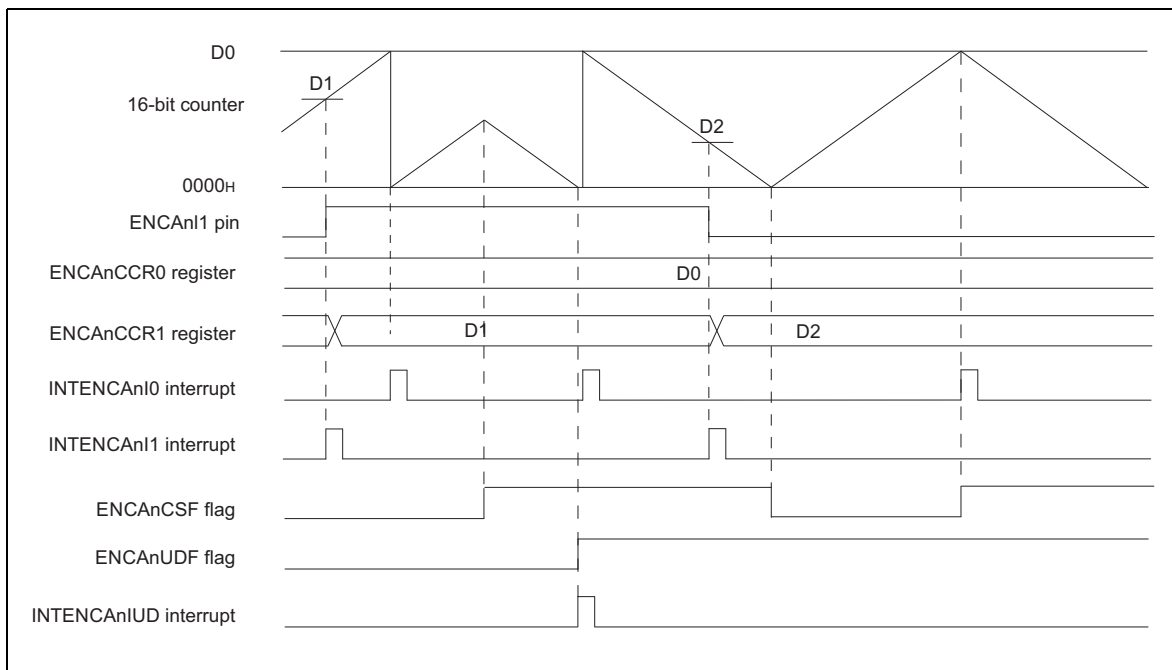

**Figure 18-21 Timing of Basic Encoder Operation 5
(Encoder Capture and Comparison Mode)**

A compare match interrupt (INTENCA_nI0) is generated when the values of the counter and register ENCA_nCCR0 (D0) match.

If further counting is upwards, the counter is cleared to 0000_H because ENCA_nECM0 = 1.

The detection of both edges on the ENCA_nI1 pin leads to storage of the counter value in the capture register (ENCA_nCCR1) and the generation of a capture interrupt (INTENCA_nI1).

An underflow interrupt (INTENCA_nIUD) is generated when the counter underflows.

ENCA_nLDE = 1, so the counter is loaded with the value from the ENCA_nCCR0 register (D0) when the counter underflows

ENCA_nLDE = 1 and ENCA_nECM[1:0] = 01_B, so counting is from 0000_H to the setting of the ENCA_nCCR0 register.

Section 19 Timer Option Module (TAPA)

The timer option module is described in this section.

19.1 Features of the Timer Option Module

Instances This product has the following number of instances of timer option modules.

Table 19-1 Instances of Timer Option Modules

Timer Option	
Instances	2
Name	TAPAn

Instances index n Throughout this section, the individual instances of the timer option function are identified by the index “n” (n = 0, 2). For example, TAPAnFLG indicates the TAPAn flag registers.

Register addresses All TAPAn register addresses are given as address offsets from the given base address, <TAPAn_base0> or <TAPAn_base1>. Each of the TAPAn base addresses is listed in the following table.

Table 19-2 Register Base Address

TAPAn	<TAPAn_base0> Address	<TAPAn_base1> Address
TAPA0	FF81 5000 _H	FFFF D400 _H
TAPA2	FF81 7000 _H	FFFF D600 _H

Clock supply The following clock signal is input to the timer option.

Table 19-3 TAPA Clock Supply

TAPAn	TAPAn Clock	Connected to
TAPA0	PCLK	Clock controller
TAPA2		

Interrupt The timer option module can generate the following interrupt requests.

Table 19-4 TAPAn Interrupt Requests

TAPAn Signals	Function	Connected to
TAPA0		
TAPA0TIPEK0	TAPA0 peak interrupt	INTTAPA0IPEK0 signal for the interrupt controller
TAPA0TIPEK1	TAPA0 peak interrupt	-
TAPA0TIVLY0	TAPA0 valley interrupt	INTTAPA0IVLY0 signal for the interrupt controller
TAPA0TIVLY1	TAPA0 valley interrupt	-
TAPA2		
TAPA2TIPEK0	TAPA2 peak interrupt	-
TAPA2TIPEK1	TAPA2 peak interrupt	-
TAPA2TIVLY0	TAPA2 valley interrupt	-
TAPA2TIVLY1	TAPA2 valley interrupt	-

Internal signals The internal signal connections of the timer option module are listed in the following table.

Table 19-5 TAPAn Internal Signal (1/2)

TAPAn Signals	Function	Connected to
TAPA0		
TAPA0THASIN	Asynchronous Hi-Z control input signal	PIC
TAPA0TSIM0	TAUB master channel 0 interrupt input signal	PIC
TAPA0TSIM1	TAUB master channel 0 interrupt input signal	-
TAPA0TUDCM0	TAUB master channel 0 up/down input signal	PIC
TAPA0TUDCM1	TAUB master channel 0 up/down input signal	-
TAPA0TCDENS0	TAUB slave channel 0 match detection input signal	PIC
TAPA0TCDENS1	TAUB slave channel 1 match detection input signal	PIC
TAPA0TCDENM0	TAUB master channel 0 cycle detection input signal	-
TAPA0TCDENM1	TAUB master channel 1 cycle detection input signal	-
TAPA0TOEM0	TAUB master channel 0 timer enabled input signal	-
TAPA0TOEM1	TAUB master channel 1 timer enabled input signal	-
TAPA0TADOUT0	A/D converter trigger output signal 0	ADCA0
TAPA0TADOUT1	A/D converter trigger output signal 1	ADCA0
TAPA2		
TAPA2THASIN	Asynchronous Hi-Z control input signal	PIC
TAPA2TSIM0	TAUB master channel 0 interrupt input signal	-
TAPA2TSIM1	TAUB master channel 0 interrupt input signal	-
TAPA2TUDCM0	TAUB master channel 0 up/down input signal	-
TAPA2TUDCM1	TAUB master channel 0 up/down input signal	-
TAPA2TCDENS0	TAUB slave channel 0 match detection input signal	-
TAPA2TCDENS1	TAUB slave channel 1 match detection input signal	-
TAPA2TCDENM0	TAUB master channel 0 cycle detection input signal	-
TAPA2TCDENM1	TAUB master channel 1 cycle detection input signal	-

Table 19-5 TAPAn Internal Signal (2/2)

TAPAn Signals	Function	Connected to
TAPA2TOEM0	TAUB master channel 0 timer enabled input signal	-
TAPA2TOEM1	TAUB master channel 1 timer enabled input signal	-
TAPA2TADOUT0	A/D converter trigger output signal 0	-
TAPA2TADOUT1	A/D converter trigger output signal 1	-

(a) Hi-Z Control Signal for TAPA0 (TAPA0THASIN)

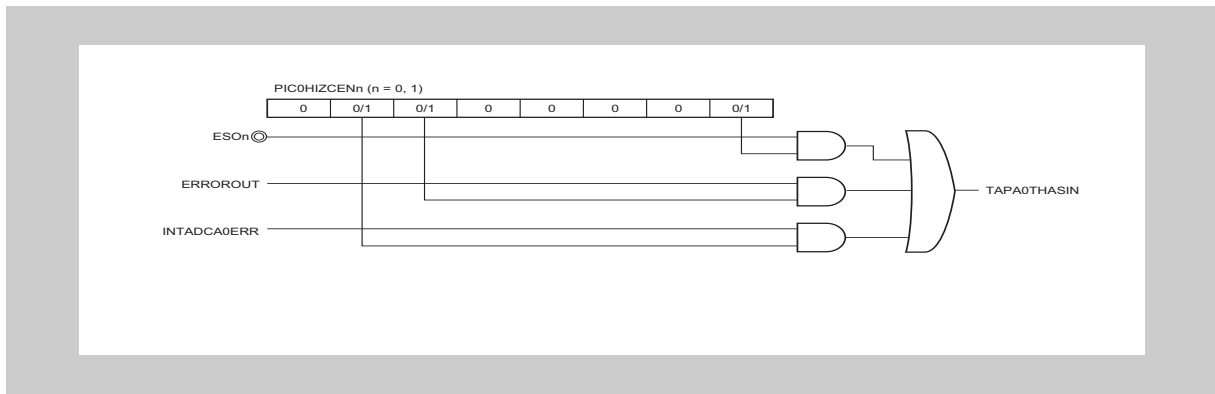

(b) Hi-Z Control Signal for TAPA2 (TAPA2THASIN)

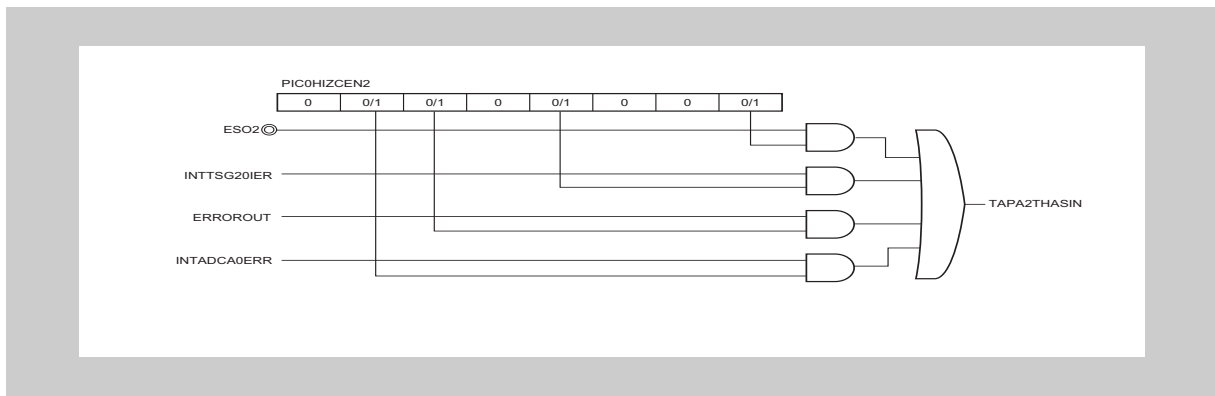

Figure 19-1 Hi-Z Control Signals for TAPA0 and TAPA2 (TAPAnTHASIN)

(1) Hi-Z Output Control Register 0 (PIC0HIZCEN0)

This register selects input signals to control Hi-Z output.

Access This register can be read/written in 8-bit units.

Address FF81 C080_H

Initial value 00_H

This register is initialized by a reset from any source.

7	6	5	4	3	2	1	0
0	PIC0HIZ CEN06	PIC0HIZ CEN05	0	0	0	0	PIC0HIZ CEN00
R	R/W	R/W	R	R	R	R	R/W

Table 19-6 Contents of the PIC0HIZCEN0 Register

Bit Position	Bit Name	Function
6	PIC0HIZCEN06	Enables and disables Hi-Z output control by the INTADCA0TERR interrupt signal. 0: Disabled 1: Enabled
5	PIC0HIZCEN05	Enables and disables Hi-Z output control by the ERROROUT signal. 0: Disabled 1: Enabled
0	PIC0HIZCEN00	Enables and disables Hi-Z output control by input to the ESO0 pin. 0: Disabled 1: Enabled

Caution 1. Set the PIC0HIZCEN0 register before enabling asynchronous Hi-Z control.

Caution 2. When the INTADCA0TERR interrupt signal and ERROROUT signal is selected, select the rising edge (TAPA0CTL0.TAPA0DCN, TAPA0DCP = 01) as the valid edge.

Note Set undefined bits in PIC0HIZCEN0 to 0.

(2) Hi-Z Output Control Register 2 (PIC0HIZCEN2)

This register selects input signals to control Hi-Z output.

Access This register can be read/written in 8-bit units.

Address FF81 C088_H

Initial value 00_H

This register is initialized by a reset from any source.

7	6	5	4	3	2	1	0
0	PIC0HIZ CEN26	PIC0HIZ CEN25	0	PIC0HIZ CEN23	0	0	PIC0HIZ CEN20
R	R/W	R/W	R	R/W	R	R	R/W

Table 19-7 Contents of the PIC0HIZCEN2 Register

Bit Position	Bit Name	Function
6	PIC0HIZCEN26	Enables and disables Hi-Z output control by the INTADCA0TERR interrupt signal. 0: Disabled 1: Enabled
5	PIC0HIZCEN25	Enables and disables Hi-Z output control by the ERROROUT signal. 0: Disabled 1: Enabled
3	PIC0HIZCEN23	Enables and disables Hi-Z output control by the INTTSG20IER interrupt signal. 0: Disabled 1: Enabled
0	PIC0HIZCEN20	Enables and disables Hi-Z output control by input to the ESO2 pin. 0: Disabled 1: Enabled

Caution 1. Set the PIC0HIZCEN2 register before enabling asynchronous Hi-Z control.

Caution 2. When the INTADCA0TERR interrupt signal , ERROROUT signal and INTTSG20IER interrupt signal is selected, select the rising edge (TAPA2CTL0.TAPA2DCN, TAPA2DCP = 01) as the valid edge.

Note Set the undefined bits in PIC0HIZCEN2 to 0.

I/O signals I/O signals for the timer option are listed in the following table.

Table 19-8 I/O Signals of TAPAn

TAPAn Signals	Function	Connected to
TAPA0		
TAPA0THZOUT0	Hi-Z control signal 0 (phase U)	Hi-Z control of phase U output signal from TAUB0 (TOUT10/TOUT11)
TAPA0THZOUT1	Hi-Z control signal 1 (phase V)	Hi-Z control of phase V output signal from TAUB0 (TOUT12/TOUT13)
TAPA0THZOUT2	Hi-Z control signal 2 (phase W)	Hi-Z control of phase W output signal from TAUB0 (TOUT14/TOUT15)
TAPA2		
TAPA2THZOUT0	Hi-Z control signal 0	Hi-Z control of TSG2001 to TSG2006 pins of TSG20

19.2 Functional Overview

Functional overview The timer option module (TAPA) is for use with the timer array unit B (TAUB) and TSG2 modules. It provides optional functions for the timers.

- Asynchronous Hi-Z control to deal with pin input
- Output of the INTn signal from the TAUB as a peak or valley interrupt is selectable.
- The INTn signal output by the TAUB provides the basis for the output of two conversion-trigger signals for the A/D converter.

19.2.1 Block Diagram

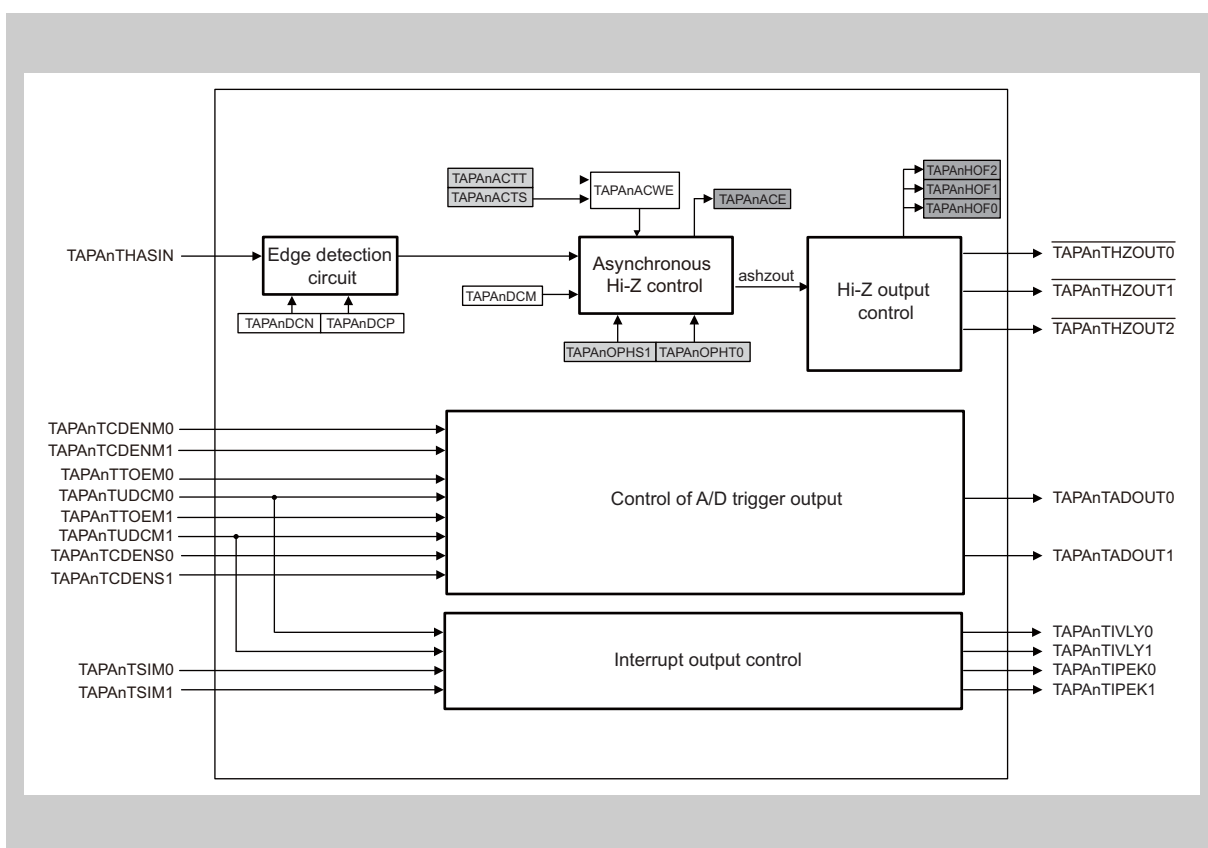

19.2.2 Peak and Valley of Timer Counter, and Peak and Valley Interrupts

In this document, the period from a TAUB down status (counting-down status) to generation of an interrupt by the master channel is defined as the valley period, and an interrupt generated to indicate this period is defined as a valley interrupt (INT-VLY). The period from a TAUB up status (counting-up status) to generation of an interrupt from the master channel is defined as the peak period, and an interrupt generated to indicate this period is defined as a peak interrupt (INT-PEK).

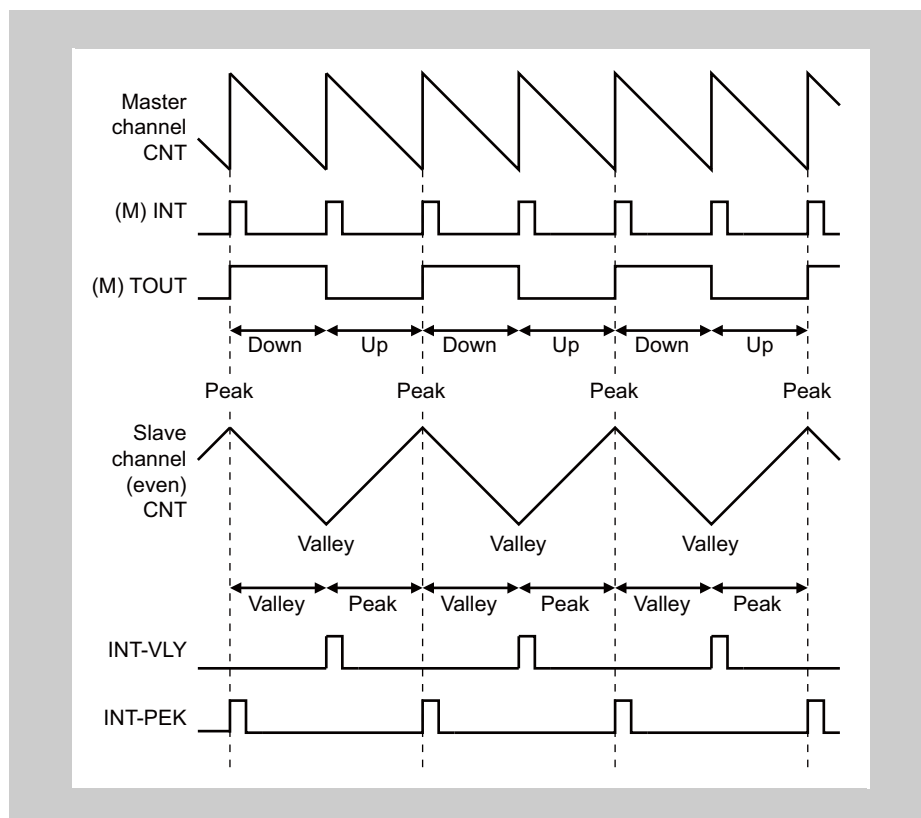

19.3 Registers

TAPAn is controlled and operated by means of the following registers.

19.3.1 Registers Overview

Table 19-9 List of Control Registers

Register Name	Symbol	Address
TAPAn control register 0	TAPAnCTL0	<TAPAn_base0> + 20 _H
TAPAn control register 1 (n = 0)*	TAPAnCTL1 (n = 0)*	<TAPAn_base0> + 24 _H (n = 0)*
TAPAn flag register	TAPAnFLG	<TAPAn_base1> + 00 _H
TAPAn asynchronous control write enable register	TAPAnACWE	<TAPAn_base1> + 04 _H
TAPAn asynchronous control start trigger register	TAPAnACTS	<TAPAn_base1> + 08 _H
TAPAn asynchronous control stop trigger register	TAPAnACTT	<TAPAn_base1> + 0C _H
TAPAn Hi-Z start trigger register	TAPAnOPHS	<TAPAn_base1> + 14 _H
TAPAn Hi-Z stop trigger register	TAPAnOPHT	<TAPAn_base1> + 18 _H

Note: * TAPA2 does not have TAPAn control register 1 (TAPAnCTL1) because their functions do not include A/D converter trigger selection.

<TAPAn_base> The base addresses <TAPAn_base> of the TAPAn are defined in the first part of this section under the heading “Register addresses”.

19.3.2 Registers Details

(1) TAPAnCTL0 - TAPAn Control Register 0

Control register 0 is used to control Hi-Z.

A value in this register can only be rewritten when TAPAnFLG.TAPAnACE = 0, and TAUBnTE of the corresponding master channel of TAUB = 0.

Access This register can be read/written in 16-bit units.

Address <TAPAn_base0> + 20_H

Initial value 0000_H

This register is initialized by a reset from any source.

15	14	13	12	11	10	9	8	7	6	5	4	3	2	1	0
0	0	0	0	0	0	0	0	0	0	0	TAPAnDCM	TAPAnDCN	TAPAnDCP	0	0
R	R	R	R	R	R	R	R	R	R	R	R/W	R/W	R/W	R	R

Table 19-10 Contents of the TAPAnCTL0 Register

Bit Position	Bit Name	Function															
4	TAPAnDCM	Clearing condition specification bit This control bit specifies the condition for clearing of the Hi-Z control outputs. 0: Manipulation of TAPAnOPHT0 is enabled regardless of the TAPAnTHASIN signal input level. 1: Manipulation of TAPAnOPHT0 is disabled when the TAPAnTHASIN signal input is at the active level. Manipulation of TAPAnOPHT0 is enabled when the TAPAnTHASIN signal input is inactive.															
3, 2	TAPAnDCN, TAPAnDCP	Hi-Z input edge selection bits These control bits specify the valid edge of TAPAnTHASIN. <table border="1" style="margin-left: 20px;"> <thead> <tr> <th>TAPAnDCN</th> <th>TAPAnDCP</th> <th>Description</th> </tr> </thead> <tbody> <tr> <td>0</td> <td>0</td> <td>Does not detect valid edges</td> </tr> <tr> <td>0</td> <td>1</td> <td>Detects a rising edge as the valid edge (active level = high)</td> </tr> <tr> <td>1</td> <td>0</td> <td>Detects a falling edge as the valid edge (active level = low)</td> </tr> <tr> <td>1</td> <td>1</td> <td>Setting prohibited</td> </tr> </tbody> </table>	TAPAnDCN	TAPAnDCP	Description	0	0	Does not detect valid edges	0	1	Detects a rising edge as the valid edge (active level = high)	1	0	Detects a falling edge as the valid edge (active level = low)	1	1	Setting prohibited
TAPAnDCN	TAPAnDCP	Description															
0	0	Does not detect valid edges															
0	1	Detects a rising edge as the valid edge (active level = high)															
1	0	Detects a falling edge as the valid edge (active level = low)															
1	1	Setting prohibited															

(2) TAPAnCTL1 - TAPAn Control Register 1

This register selects a trigger for the A/D converter.

Access This register can be read/written in 8-bit units.

Address <TAPAn_base0> + 24_H

Initial value 00_H

This register is initialized by a reset from any source.

7	6	5	4	3	2	1	0
0	0	0	0	TAPAn ATS3	TAPAn ATS2	TAPAn ATS1	TAPAn ATS0
R	R	R	R	R/W	R/W	R/W	R/W

Table 19-11 Contents of the TAPAnCTL1 Register

Bit Position	Bit Name	Function															
3, 2	TAPAn ATS[3:2]	<p>A/D converter trigger 1 select bits These control bits specify the signal for output as A/D converter conversion trigger output 1 (TAPAnTADOUT1).</p> <table border="1"> <thead> <tr> <th>TAPAn ATS3</th> <th>TAPAn ATS2</th> <th>Description</th> </tr> </thead> <tbody> <tr> <td>0</td> <td>0</td> <td>Outputs INT while the master channel is in the down state.</td> </tr> <tr> <td>0</td> <td>1</td> <td>Outputs INT while the master channel is in the up state.</td> </tr> <tr> <td>1</td> <td>0</td> <td>Outputs INT while the master channel is in the down/up state.</td> </tr> <tr> <td>1</td> <td>1</td> <td>Outputs INT and a valley interrupt of the master channel (TAPAnTIVLYn0) while the master channel is in the down/up state.</td> </tr> </tbody> </table>	TAPAn ATS3	TAPAn ATS2	Description	0	0	Outputs INT while the master channel is in the down state.	0	1	Outputs INT while the master channel is in the up state.	1	0	Outputs INT while the master channel is in the down/up state.	1	1	Outputs INT and a valley interrupt of the master channel (TAPAnTIVLYn0) while the master channel is in the down/up state.
TAPAn ATS3	TAPAn ATS2	Description															
0	0	Outputs INT while the master channel is in the down state.															
0	1	Outputs INT while the master channel is in the up state.															
1	0	Outputs INT while the master channel is in the down/up state.															
1	1	Outputs INT and a valley interrupt of the master channel (TAPAnTIVLYn0) while the master channel is in the down/up state.															
1, 0	TAPAn ATS[1:0]	<p>A/D converter trigger 0 select bits These control bits specify the signal for output as A/D converter conversion trigger output 0 (TAPAnTADOUT0).</p> <table border="1"> <thead> <tr> <th>TAPAn ATS1</th> <th>TAPAn ATS0</th> <th>Description</th> </tr> </thead> <tbody> <tr> <td>0</td> <td>0</td> <td>Outputs INT while the master channel is in the down state.</td> </tr> <tr> <td>0</td> <td>1</td> <td>Outputs INT while the master channel is in the up state.</td> </tr> <tr> <td>1</td> <td>0</td> <td>Outputs INT while the master channel is in the down/up state.</td> </tr> <tr> <td>1</td> <td>1</td> <td>Outputs INT and a valley interrupt of the master channel (TAPAnTIVLY0) while the master channel is in the down/up state.</td> </tr> </tbody> </table>	TAPAn ATS1	TAPAn ATS0	Description	0	0	Outputs INT while the master channel is in the down state.	0	1	Outputs INT while the master channel is in the up state.	1	0	Outputs INT while the master channel is in the down/up state.	1	1	Outputs INT and a valley interrupt of the master channel (TAPAnTIVLY0) while the master channel is in the down/up state.
TAPAn ATS1	TAPAn ATS0	Description															
0	0	Outputs INT while the master channel is in the down state.															
0	1	Outputs INT while the master channel is in the up state.															
1	0	Outputs INT while the master channel is in the down/up state.															
1	1	Outputs INT and a valley interrupt of the master channel (TAPAnTIVLY0) while the master channel is in the down/up state.															

(3) TAPAnFLG - TAPAn Flag Register

This flag register is used to control Hi-Z

Access This register can be read/written in 16-bit units.

Address <TAPAn_base1> + 00_H

Initial value 0000_H

This register is initialized by a reset from any source.

15	14	13	12	11	10	9	8	7	6	5	4	3	2	1	0
0	0	0	0	0	TAPAn HOF2	TAPAn HOF1	TAPAn HOF0	0	0	0	0	0	0	0	TAPAn ACE
R	R	R	R	R	R	R	R	R	R	R	R	R	R	R	R

Table 19-12 Contents of the TAPAnFLG Register

Bit Position	Bit Name	Function
10 to 8	TAPAn HOFm	TAPAnTHZOUTm output monitor bit (m = 0 to 2) This bit monitors the TAPAnTHZOUTm output. 0: The TAPAnTHZOUTm output is at the low level. 1: The TAPAnTHZOUTm output is at the high level.
0	TAPAn ACE	Asynchronous Hi-Z control enable bit This bit indicates the state of asynchronous Hi-Z control (TAPAnTHASIN). 0: Asynchronous Hi-Z control is stopped. 1: Asynchronous Hi-Z control is enabled. The conditions for setting and clearing this bit are as follows. Clearing condition: Writing 1 to TAPAnACTT while TAPAnACWE = 1. Setting condition: Writing 1 to TAPAnACTS while TAPAnACWE = 1.

(4) TAPAnACWE - TAPAn Asynchronous Control Write Enable Register

This register enables writing for asynchronous Hi-Z control.

Access This register can be read/written in 8-bit units.

Address <TAPAn_base1> + 04_H

Initial value 00_H

This register is initialized by a reset from any source.

7	6	5	4	3	2	1	0
0	0	0	0	0	0	0	TAPAn ACWE
R	R	R	R	R	R	R	R/W

Table 19-13 Contents of the TAPAnACWE Register

Bit Position	Bit Name	Function
0	TAPAn ACWE	Asynchronous control write enable bit This is a write-enable bit for asynchronous Hi-Z control. After 1 has been written to this bit, it is automatically cleared to 0 by writing 1 to TAPAnACTS and TAPAnACTT. 0: Disables writing to TAPAnACTS and TAPAnACTT. 1: Enables writing to TAPAnACTS and TAPAnACTT.

(5) TAPAnACTS - Asynchronous Control Start Trigger Register

This register enables the start trigger for asynchronous Hi-Z control.

Access This register can be read/written in 8-bit units.

Address <TAPAn_base1> + 08_H

Initial value 00_H

This register is initialized by a reset from any source.

7	6	5	4	3	2	1	0
0	0	0	0	0	0	0	TAPAn ACTS
R	R	R	R	R	R	R	W

Table 19-14 Contents of the TAPAnACTS Register

Bit Position	Bit Name	Function
0	TAPAn ACTS	Asynchronous control start trigger bit This bit enables the start trigger for asynchronous Hi-Z control. The setting of this bit is only valid when TAPAnACWE = 1. 0: Writing 0 to this bit is ignored (no function). 1: Enables asynchronous Hi-Z control if TAPAnACE = 1.

(6) TAPAnACTT - TAPAn Asynchronous Control Stop Trigger Register

This register enables the stop trigger for asynchronous Hi-Z control.

Access This register can be read/written in 8-bit units. This register is always read as 00_H.

Address <TAPAn_base1> + 0C_H

Initial value 00_H

This register is initialized by a reset from any source.

7	6	5	4	3	2	1	0
0	0	0	0	0	0	0	TAPAn ACTT
R	R	R	R	R	R	R	W

Table 19-15 Contents of the TAPAnACTT

Bit Position	Bit Name	Function
0	TAPAn ACTT	Asynchronous control stop trigger bit This bit enables the stop trigger for asynchronous Hi-Z control. The setting of this bit is only valid when TAPAnACWE = 1. 0: Writing 0 to this bit is ignored (no function). 1: Stops asynchronous Hi-Z control if TAPAnACE = 0.

(7) TAPAnOPHS - TAPAn Hi-Z Start Trigger Register

This register sets the start trigger for a Hi-Z control signal ($\overline{\text{TAPATHZOUT0}}$, $\overline{\text{TAPATHZOUT1}}$ or $\overline{\text{TAPATHZOUT2}}$).

Access This register can be read/written in 8-bit units. This register is always read as 00_H.

Address <TAPAn_base1> + 14_H

Initial value 00_H

This register is initialized by a reset from any source.

7	6	5	4	3	2	1	0
0	0	0	0	0	0	0	TAPAn OPHS0
R	R	R	R	R	R	R	W

Table 19-16 Contents of the TAPAnOPHS Register

Bit Position	Bit Name	Function
0	TAPAn OPHS0	Hi-Z control signal start trigger 0 bit This bit sets the start trigger for a Hi-Z control signal. 0: The read value is 0 and writing 0 to this bit is ignored (no function). 1: Sets the corresponding Hi-Z control signal ($\overline{\text{TAPAnTHZOUT0}}$, $\overline{\text{TAPAnTHZOUT1}}$ or $\overline{\text{TAPAnTHZOUT2}}$) to the low level.

(8) TAPAnOPHT - TAPAn Hi-Z Stop Trigger Register

This register sets the stop trigger for a Hi-Z control signal ($\overline{\text{TAPATHZOUT0}}$, $\overline{\text{TAPATHZOUT1}}$ or $\overline{\text{TAPATHZOUT2}}$).

Access This register can be read/written in 8-bit units. This register is always read as 00_H.

Address <TAPAn_base1> + 18_H

Initial value 00_H

This register is initialized by a reset from any source.

7	6	5	4	3	2	1	0
0	0	0	0	0	0	0	TAPAn OPHT0
R	R	R	R	R	R	R	W

Table 19-17 Contents of the TAPAnOPHT Register

Bit Position	Bit Name	Function
0	TAPAn OPHT0	Hi-Z control signal stop trigger 0 bit This bit sets the stop trigger for a Hi-Z control signal. 0: The read value is 0 and writing 0 to this bit is ignored (no function). 1: Sets a Hi-Z control signal ($\overline{\text{TAPAnTHZOUT0}}$, $\overline{\text{TAPAnTHZOUT1}}$ or $\overline{\text{TAPAnTHZOUT2}}$) to the high level.

19.4 Basic Functions

19.4.1 Hi-Z Control Functions

(1) Purpose of Hi-Z Control Function

Abnormal operation in timer motor-control under CPU control leads to rotation of the externally connected motor also becoming abnormal. In such a case, this function forcibly sets the motor control output to the Hi-Z state, independently of control by the CPU.

(2) Overview of Hi-Z Control Function

The following method is available for controlling Hi-Z states

- Asynchronous input Hi-Z control for pin inputs
 - Controls the Hi-Z control output signals $\overline{\text{TAPAnTHZOUT0}}$ (phase U), $\overline{\text{TAPAnTHZOUT1}}$ (phase V) and $\overline{\text{TAPAnTHZOUT2}}$ (phase W) asynchronously.

(3) Hi-Z Control and Its Operation

Function	Operation
Asynchronous Hi-Z control corresponding to pin input	This function detects analog inputs that are asynchronous and forcibly stops TOUTn output from the corresponding timer module (TAUB, TSG2) in response. Device outputs become Hi-Z while TAPAnTHASIN is active and until software sends a stop request.

19.4.2 Asynchronous Hi-Z Control for Pin Inputs

(1) An Example of System Configuration of Asynchronous Hi-Z Control for Pin Inputs

When an external error detection signal is received, an interrupt is generated and, at the same time, the motor-driving signal output is set to the Hi-Z state.

This module assumes that microcontroller operation may hang when an error occurs. To handle such situations, external error detection signals are continuously processed so that the motor-driving signal can be set to the Hi-Z state even if no clock signal is being supplied.

This module only detects an error as an edge of the error-detection signal. A fixed output level is not detected as an error (the signal has no edge).

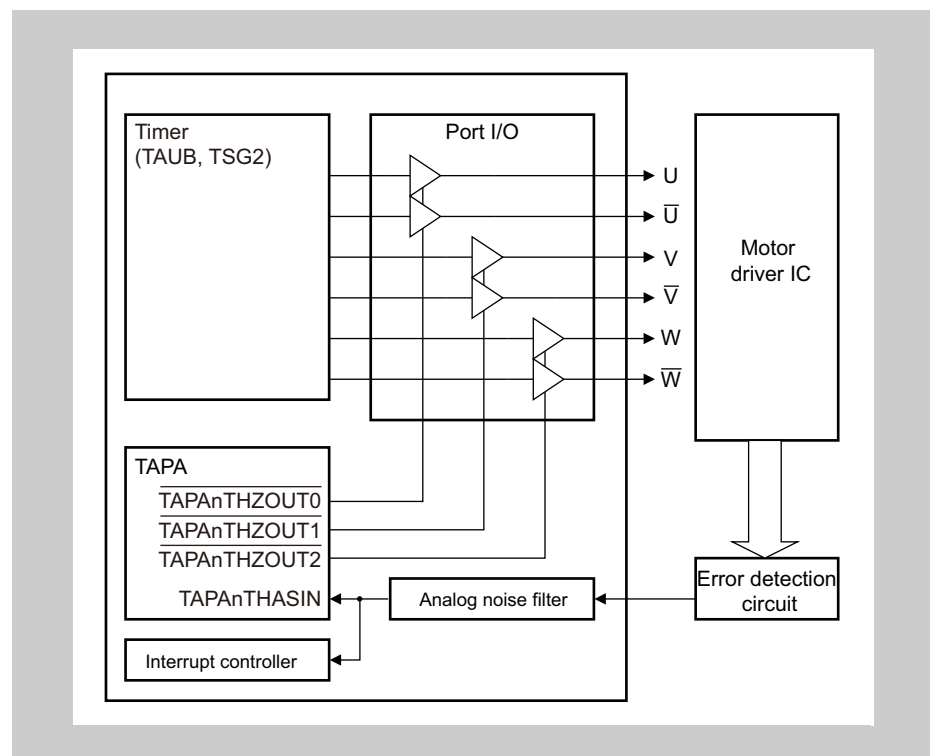

(2) Basic Operation in Hi-Z Control for Asynchronous Inputs**(a) Hi-Z Control when $TAPAnCTL0.TAPAnDCM = 0$, $TAPAnDCP = 1$, and $TAPAnDCN = 0$**

$\overline{TAPAnTHZOUT0}$ goes to the low level on detection of a valid edge of the asynchronous input ($TAPAnTHASIN$).

Output is forcibly stopped (by port control for Hi-Z output) as long as the $\overline{TAPAnTHZOUT0}$ output is at the low level.

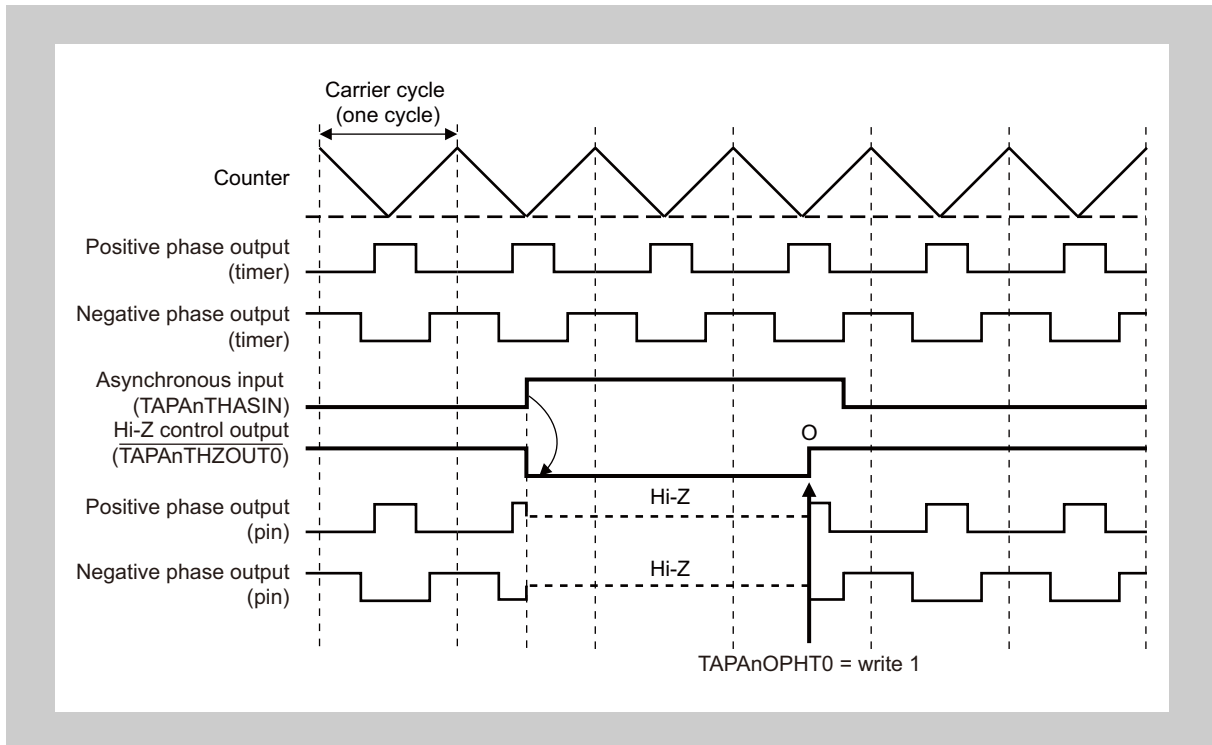

$\overline{TAPAnTHZOUT0}$ goes to the low level in response to detection of a rising edge of the asynchronous input ($TAPAnTHASIN$).

$\overline{TAPAnTHZOUT0}$ goes to the high level in response to writing 1 to Hi-Z stop trigger 0 ($TAPAnOPHT0$), regardless of the level of $TAPAnTHASIN$.

(b) Hi-Z Control when TAPAnCTL0.TAPAnDCM = 1, TAPAnDCP = 1, TAPAnDCN = 0

$\overline{\text{TAPAnTHZOUT0}}$ goes to the low level in response to detection of a valid edge of the asynchronous input signal (TAPAnTHASIN).

Output is forcibly stopped (by port control for Hi-Z output) as long as the $\overline{\text{TAPAnTHZOUT0}}$ output is at the low level.

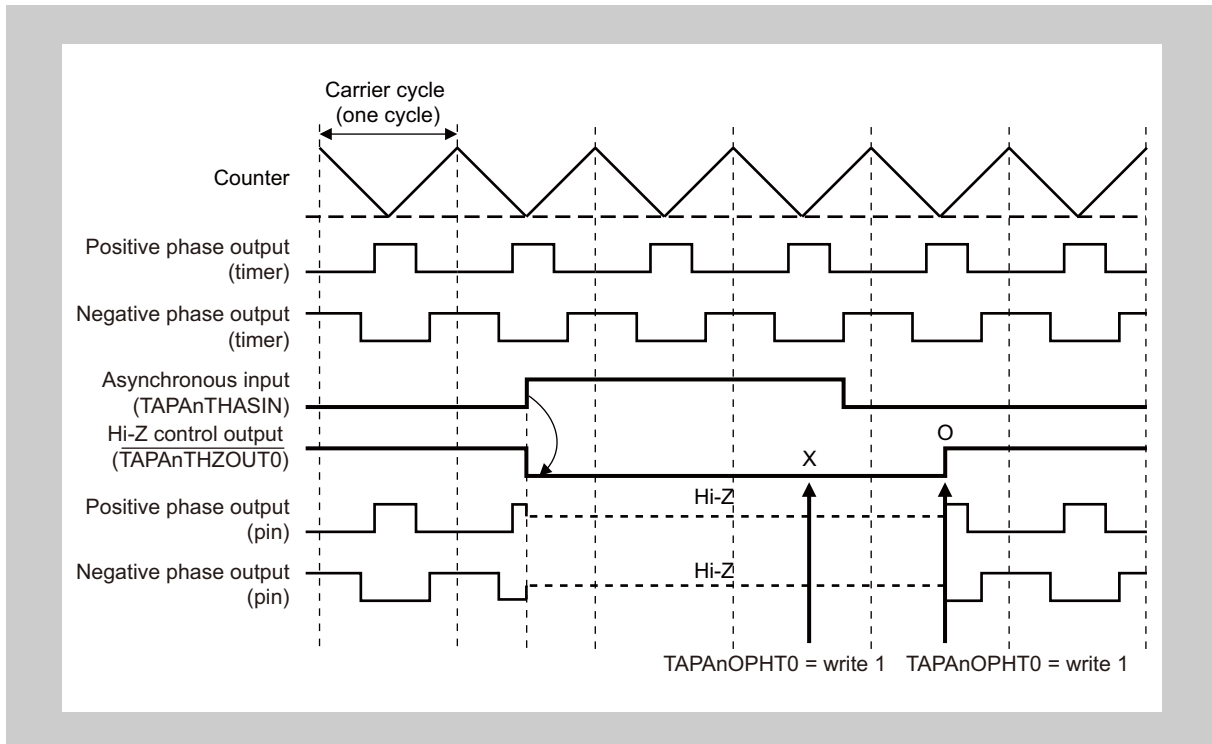

$\overline{\text{TAPAnTHZOUT0}}$ goes to the low level in response to detection of a rising edge of the asynchronous input signal (TAPAnTHASIN).

Writing of 1 to Hi-Z stop trigger 0 (TAPAnOPHT0) is ignored as long as the asynchronous input signal (TAPAnTHASIN) is at the active level (high because TAPAnDCP = 1).

After the asynchronous input signal (TAPAnTHASIN) is switched to the inactive level (low because TAPAnDCP = 1), $\overline{\text{TAPAnTHZOUT0}}$ goes to the high level when 1 is written to Hi-Z stop trigger 0 (TAPAnOPHT0).

(3) Software Operations for Asynchronous Input Hi-Z Control

This module allows software control of the output of Hi-Z control signals.

Hi-Z start trigger 0 (TAPAnOPHS0) and Hi-Z stop trigger 0 (TAPAnOPHT0) are used to control TAPAnTHZOUT0, TAPAnTHZOUT1, and TAPAnTHZOUT2.

(a) Operation of the Hi-Z Start Trigger (TAPAnOPHS)

TAPAn DCM	Operation
0/1	Writing 1 to the TAPAnOPHS0 bit places the TAPAnTHZOUT0, TAPAnTHZOUT1 and TAPAnTHZOUT2 signals at the low level.

(b) Operation of the Hi-Z Stop Trigger (TAPAnOPHT) during Hi-Z Control in Response to Asynchronous Input

The Hi-Z stop trigger operates as follows.

TAPAn DCM	Operation
0	Writing 1 to the TAPAnOPHT0 bit places the TAPAnTHZOUT0, TAPAnTHZOUT1 and TAPAnTHZOUT2 signals at the high level.
1	If TAPAnTHASIN is at the inactive level, writing 1 to the TAPAnOPHT0 bit places the TAPAnTHZOUT0, TAPAnTHZOUT1 and TAPAnTHZOUT2 signals at the high level. If TAPAnTHASIN is at the active level, writing of 1 to the TAPAnOPHT0 bit is ignored.

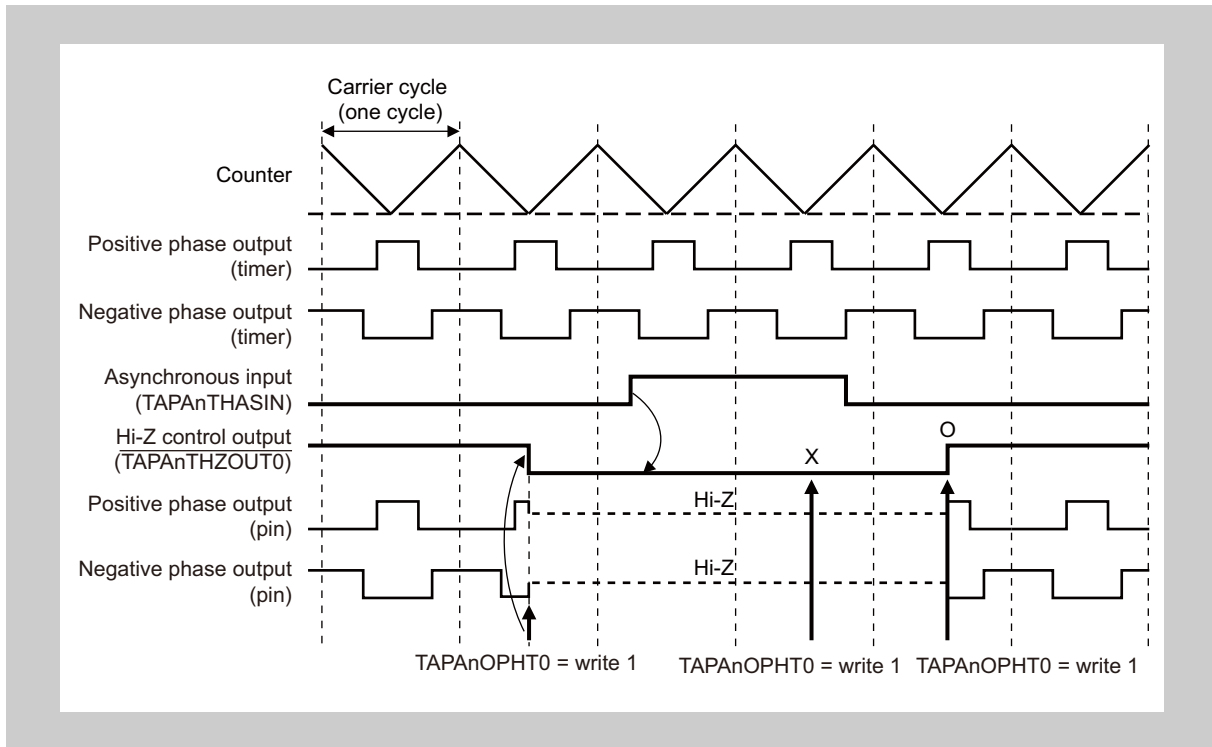

Figure 19-2 Operation of $\overline{\text{TAPAnTHZOUT0}}$ when $\text{TAPAnDCM} = 1$, $\text{TAPAnDCP} = 1$, and $\text{TAPAnDCN} = 0$

$\overline{\text{TAPAnTHZOUT0}}$ goes to the low level in response to the writing of 1 to TAPAnOPHT0 .

After that, $\overline{\text{TAPAnTHZOUT0}}$ remains at the low level even if a rising edge of TAPAnTHASIN is detected.

Writing to TAPAnOPHT0 is ignored as long as TAPAnTHASIN is at the active level (high when $\text{TAPAnDCN} = 0$ and $\text{TAPAnDCP} = 1$).

After a falling edge of TAPAnTHASIN is detected, $\overline{\text{TAPAnTHZOUT0}}$ goes to the high level when 1 is written to TAPAnOPHT0 while TAPAnTHASIN is at the inactive level (low when $\text{DCN} = 0$ and $\text{DCP} = 1$).

(4) Operating Procedure Example for Hi-Z Control in Response to Asynchronous Input

An example of the operating procedure for Hi-Z control in response to asynchronous input is as follows (the table only covers settings for the timer option module because this operation does not depend on timer operations).

	Operation	State of TAPA
Initial settings	Setting in the TAPAnCTL0 register. Set TAPAnDCP and TAPAnDCN (input edge selection). Set TAPAnDCM (clearing mode selection).	Hi-Z control in response to asynchronous input is stopped (TAPAnFLG.TAPAnACE = 0).
Starting operation	Setting in the TAPAnACWE register: Set the TAPAnACWE bit to 1. Setting in the TAPAnACTS register: Set the TAPAnACTS bit to 1.	Writing to the TAPAnACTS bit is enabled. TAPAnFLG.TAPAnACE = 1, enabling Hi-Z control in response to asynchronous input.
During operation	To start Hi-Z control of an output from the timer: - Control is by the TAPAnOPHS0 bit of TAPA - Control is by the Hi-Z input signal (TAPAnTHASIN) for TAPA To stop Hi-Z control of output from the timer: - Control is by the TAPAnOPHT0 bit of TAPA (if TAPAnDCM = 0) - TAPAnOPHT0 is used if the Hi-Z input signal for TAPA (TAPAnTHASIN) is at the inactive level (if TAPAnDCM = 1) The state of TAPA operations can be read from the TAPAnFLG register at all times.	On detection of input of the starting edge of the Hi-Z input signal (TAPAnTHASIN) or setting of the start trigger bit (TAPAnOPHS0 = 1), the Hi-Z controller switches the $\overline{\text{TAPAnTHZOUT0}}$, $\overline{\text{TAPAnTHZOUT1}}$ and $\overline{\text{TAPAnTHZOUT2}}$ pins to low-level output. In accord with the operating mode settings in TAPAnDCM, the Hi-Z controller switches the $\overline{\text{TAPAnTHZOUT0}}$, $\overline{\text{TAPAnTHZOUT1}}$ and $\overline{\text{TAPAnTHZOUT2}}$ pins to high-level outputs in response to setting of the stop trigger bit (TAPAnOPHT0 = 1).
Stopping operation	Setting in the TAPAnACWE register: Set the TAPAnACWE bit to 1. Setting in the TAPAnACTT register: Set the TAPAnACTT bit to 1.	Writing to the TAPAnACTT bit is enabled. TAPAnFLG.TAPAnACE = 0, stopping asynchronous Hi-Z control

Restart operation

19.4.3 Selection of INT Signal Output

(1) Configuration of INT Signal Output Selection

This function outputs peak or valley interrupts by using the INT signal (TAPAnTSIM0) and up/down input signals (TAPAnTUDCM0) output from the triangle-wave carrier-cycle generation channel (master) of the TAUB module.

An TAPAnTSIM0 signal from the master that arrives while the TAPAnTUDCM0 signal from the master channel of the TAUB is at the high level is regarded as a peak interrupt and leads to output of the TAPAnTIPEK0 signal.

An TAPAnTSIM0 signal from the master that arrives while the TAPAnTUDCM0 signal from the master channel of the TAUB is at the low level is regarded as a valley interrupt and leads to output of the TAPAnTIVLY0 signal.

The PIC0REG2n0 register is used to select channel 0, 2, or 8 for the TAPAnTSIM0 and TAPAnTUDCM0 signals.

Timer I/O control register 200 (PIC0REG200)

Access This register can be read/written in 32-bit units.

Address FF81 C0C0_H

Initial value 0000 0000_H

This register is initialized by a reset from any source.

31	30	29	28	27	26	25	24
0	0	0	0	0	0	PIC0REG 20025	PIC0REG 20024
R	R	R	R	R	R	R/W	R/W
23	22	21	20	19	18	17	16
0	0	0	0	0	0	0	0
R	R	R	R	R	R	R	R
15	14	13	12	11	10	9	8
0	0	0	0	0	0	0	0
R	R	R	R	R	R	R	R
7	6	5	4	3	2	1	0
0	0	0	0	0	0	0	0
R	R	R	R	R	R	R	R

Bit Position	Bit Name	Function
25, 24	PIC0REG 20025, PIC0REG 20024	Selects the TAUB channel to be used by TAPAnTSIM0 and TAPAnTUDCM0. 0 0: None 0 1: TAUBn channel 0 1 0: TAUBn channel 2 1 1: TAUBn channel 8

Caution The bit might be set to 0 by the PIC function (see section 24, Peripheral Interconnection (PIC)). In that case, apply the bit definition of the corresponding function.

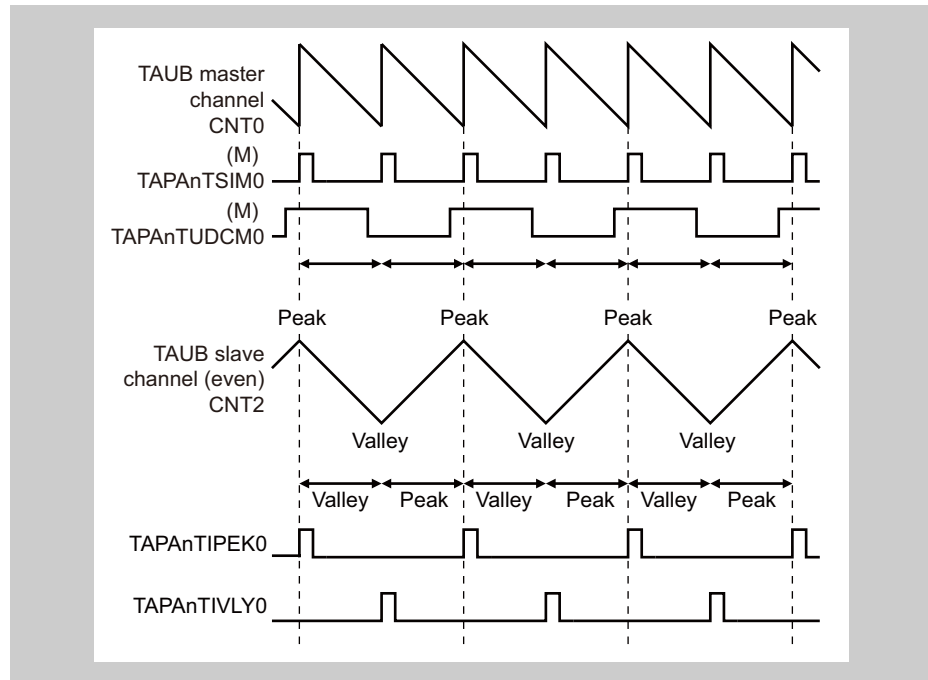

Figure 19-3 Example of Operations in Response to Master Channel 0 of TAUB

- TAUB**
- The master channel of TAUB generates a triangle-wave carrier-cycle. The TAUB module outputs TAPAnTSIM0 and toggles the up/down signal in accord with the setting of TAPAnTUDCM0 per half cycle of this carrier wave.
- TAPA**
- The TAPA module handles TAPAnTSIM0 arriving while TAPAnTUDCM0 is high as a peak interrupt and outputs the TAPAnTIPEK0 signal in response.
 - The TAPA module handles TAPAnTSIM0 arriving while TAPAnTUDCM0 is low as a valley interrupt and outputs the TAPAnTIVLY0 signal in response.

Caution Combined circuits handle output of the TAPAnTIPEK0/TAPAnTIVLY0 signals and operate regardless of the operating mode.

When the TAPAnTIPEK0/TAPAnTIVLY0 signals are not in use, they must be controlled by using the interrupt mask bits as described under Section 4 Interrupt Controller Control Registers.

(2) Operating Procedure for Selecting INT Signal Output

The procedure for selecting INT signal output is as follows.

	Operation	States of the TAUB and TAPA Modules	
 Restart operation	Initial settings	The TAPA module does not require initial settings. Initialize the TAUB module. Determine the timer operating mode.	TAUB and TAPA are stopped.
	Starting operation	Start the TAUB module.	TAUB starts counting.
	During operation	TAUB runs in accord with the settings for the various functions.	The INT signal output selector outputs a peak interrupt (TAPAnTIPEK0) or a valley interrupt (TAPAnTIVLY0) for control cycle 0. This is based on interrupt input (TAPAnTSIM0) and up/down input (TAPAnTUDCM0) from TAUB.
	Stopping operation	Stop the TAUB module.	TAUB stops counting.

19.4.4 Selecting a Trigger to Start Conversion by the A/D Converter

The TAPA is capable of producing triggers to start conversion by the A/D converter (TAPAnTADOUT0 and TAPAnTADOUT1). A trigger signal is produced from the INT and TOUT signals from the triangle-wave carrier-cycle generation channel (master) of the TAUB and the INT signal output from the channel selected for operation with the trigger to start conversion by the A/D converter.

(1) Configuration for Selecting the Triggers for Conversion by the A/D Converter

Table 19-18 Signals Used in Generating the TAPATADOUT Signals

Output Signal	Up/Down Input	Slave Match Detection Signal	Valley Interrupt Signal
TAPAnTADOUT0	TAPAnTUDCM0	TAPAnTCDENS0	TAPAnTIVLY0
TAPAnTADOUT1	TAPAnTUDCM0	TAPAnTCDENS1	TAPAnTIVLY0

- Note
- For the up/down input and valley signals, see section 19, Selection of INT Signal Output.
 - The slave channel is selected for the slave match detection signal by the following registers. For these registers, see section 24.4.2.3(1), A/D Converter Trigger Output Control Register 40j (PIC0ADTEN40j).
 - TAPAnCDENS0: PIC0ADTEN4n1
 - TAPAnCDENS1: PIC0ADTEN4n2

Table 19-19 Operation of TAPAnCTL1.TAPAnATS[1:0] and TAPAnTADOUT0

TAPAnATS1	TAPAnATS0	Description
0	0	The INT signal from slave 0 is output as TAPAnTADOUT0 while master 0 of the TAUB module is in the down state.
0	1	The INT signal from slave 0 is output as TAPAnTADOUT0 while master 0 of the TAUB module is in the up state.
1	0	The INT signal from slave 0 of TAUB is output as TAPAnTADOUT0.
1	1	The INT and TAPAnTIVLY0 (valley interrupt signal 0) signals from slave 0 of TAUB are output as TAPAnTADOUT0.

Table 19-20 Operation of TAPAnCTL1.TAPAnATS[3:2] and TAPAnTADOUT1

TAPAnATS3	TAPAnATS2	Description
0	0	The INT signal from slave 1 is output as TAPAnTADOUT1 while master 0 of the TAUB module is in the down state.
0	1	The INT signal from slave 1 is output as TAPAnTADOUT1 while master 0 of the TAUB module is in the up state.
1	0	The INT signal from slave 1 of TAUB is output as TAPAnTADOUT1.
1	1	The INT and TAPAnTIVLY0 (valley interrupt signal 0) signals from slave 1 of TAUB are output as TAPAnTADOUT1.

(2) Waveforms in Control of A/D Converter Trigger Output in Triangle-Wave PWM Mode

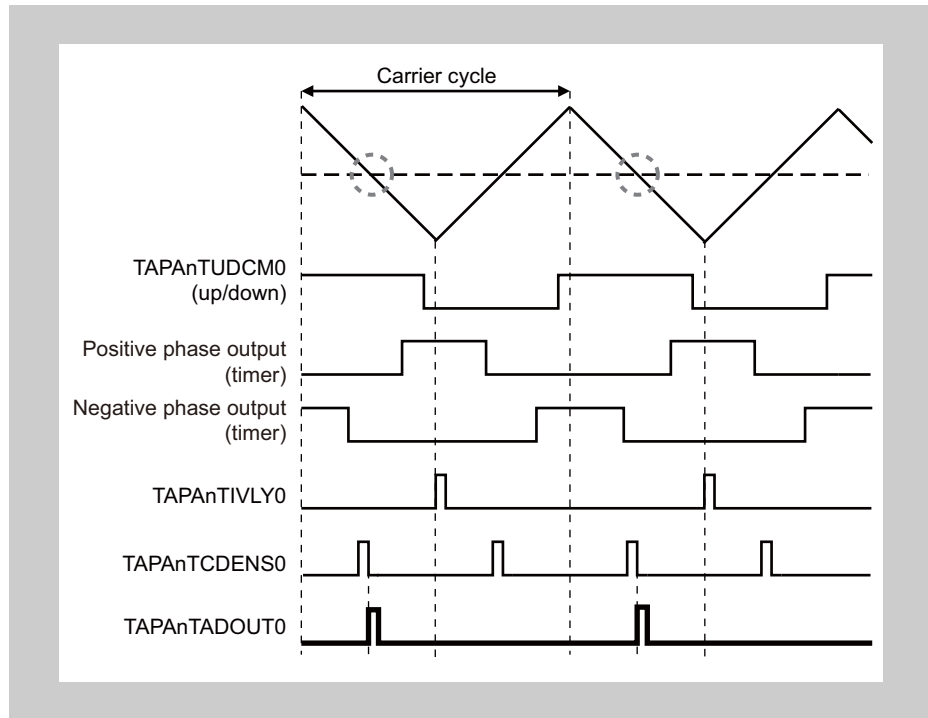

Figure 19-4 TAPAnATS = {0, 0}: INT Output while Master Channel is in the Down State

An INT signal from the slave while the master is in the down state is output as a trigger to start conversion by the A/D converter.

An INT signal from the slave while the master is in the up state is not output.

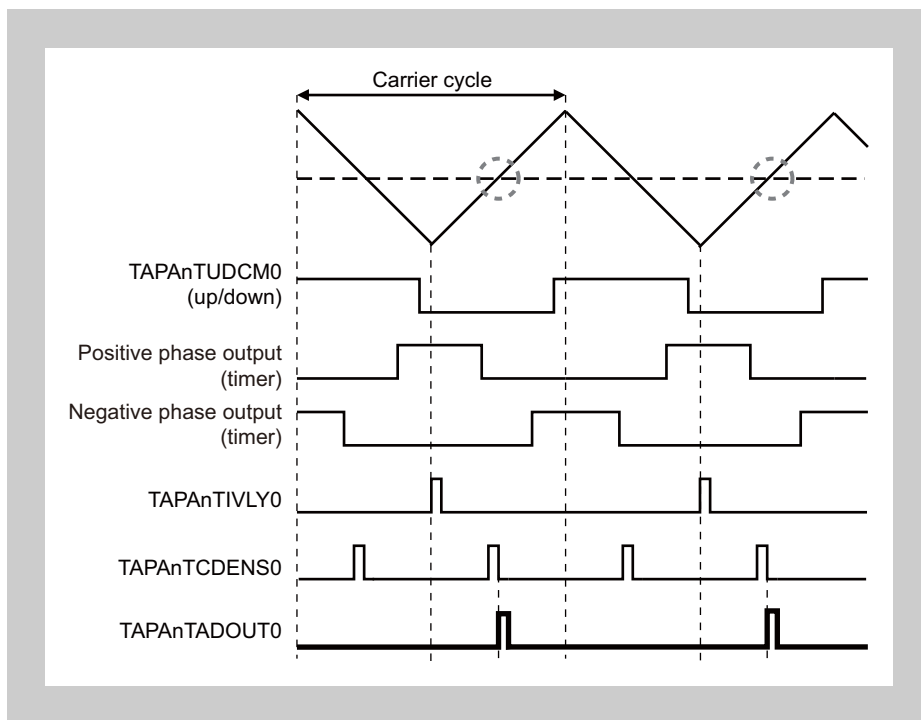

Figure 19-5 TAPAnATS = {0,1}: INT Output while Master Channel is in the Up State

An INT signal from the slave while the master is in the up state is output as a trigger to start conversion by the A/D converter.

An INT signal from the slave while the master is in the down state is not output.

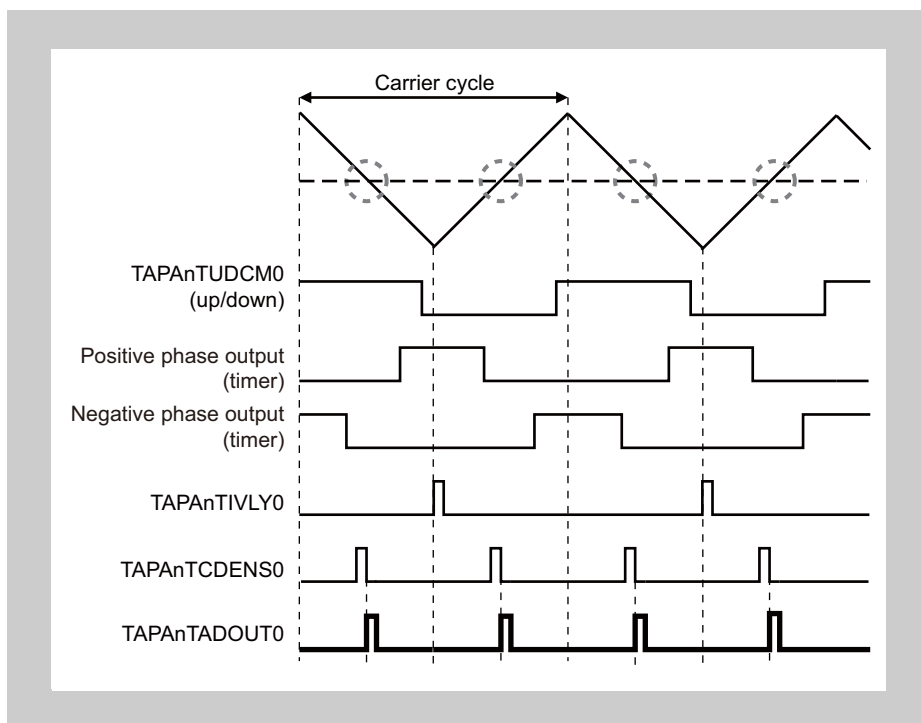

Figure 19-6 TAPAnATS = {1, 0}: INT Output while Master Channel is in either the Down or Up State

An INT signal from the slave at any time is output as a trigger to start conversion by the A/D converter.

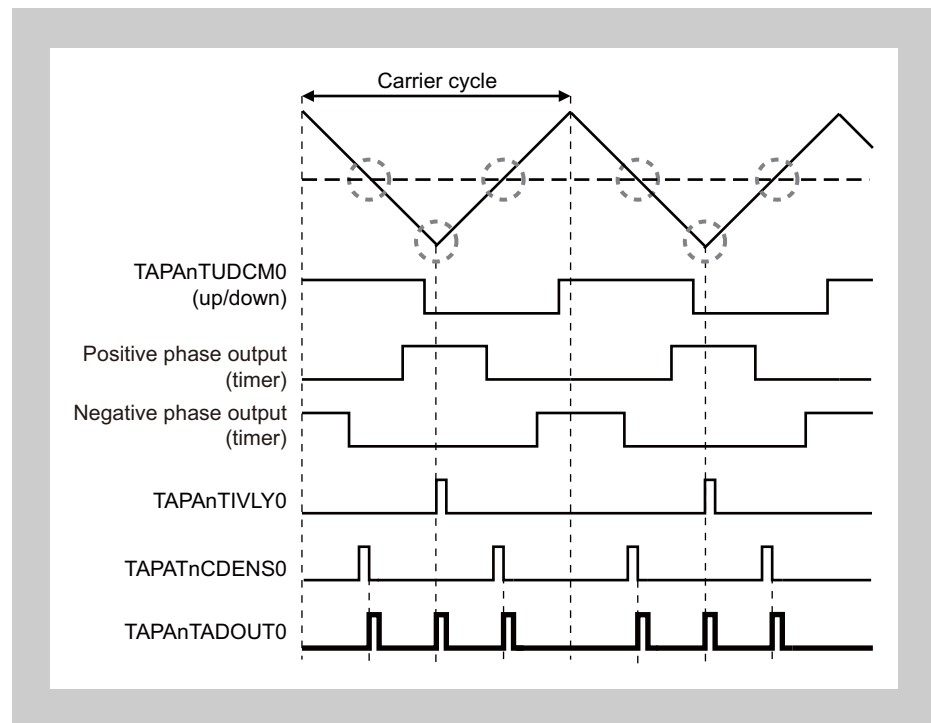
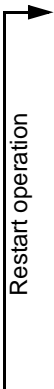

Figure 19-7 TAPAnATS = {1, 1}: Output of INT and Valley Interrupt while Master Channel is in either the Down or Up State

An INT signal or valley interrupt signal from the slave is output as a trigger to start conversion by the A/D converter.

(3) Operating Procedure for Setting a Trigger to Start Conversion by the A/D Converter

The operating procedure for setting a trigger to start conversion by the A/D converter is as follows.

	Operation	States of TAUB and TAPA
 Restart operation	Initial settings	Initialize TAUB. Determine the timer's operating mode.
		Setting in the TAPAnCTL1 register. Set TAPAnATS[1:0] bits (for TAPAnTADOUT0). Set TAPAnATS[3:2] (for TAPAnTADOUT1).
	Start operation	Start the TAUB module.
	During operation	TAUB runs in accord with the settings for the various functions.
		The A/D converter conversion trigger selector outputs TAPAnTADOUT0 in accord with the settings of TAPAnATS[1:0] or TAPAnTADOUT1 in accord with the settings of TAPAnATS[3:2], based on the slave match detection signal (TAPAnTCDENS1 or TAPAnTCDENS0) and up/down input (TAPAnTUDCM0) and the valley interrupt signal (TAPAnTIVLY0) generated by TAPA.
	Stopping operation	Stopping the TAUB module.
		TAUB stops counting.

Section 20 CAN Controller (FCN)

This product features on-chip CAN (Controller Area Network) controller that complies with the CAN protocol as standardized in ISO 11898.

This section contains a generic description of the CAN controller (FCN).

The first part describes instances, register base addresses, input/output signal names, etc.

20.1 FCN Features

Instances This product has 2 instances of the CAN controller.

Table 20-1 Instances of FCN

CAN Controller	
Instances	2
Name	FCN0, FCN1

Instances index n Throughout this section, the instance of a CAN controller is identified by the index “n” (n = 0, 1), for example, FCN0GMCLCTL for the FCN0 control register.

Table 20-2 Message Buffers of FCNn

FCNn Instance	Number m of Message Buffers
FCN0	32
FCN1	32

Message buffers index m Throughout this section, the FCN message buffer registers are identified by “m” (m: 000 to 031), for example FCNnMmDAT4B for FCN instance n, message data byte 4 of message buffer register m.

Register address All CAN controller register addresses are given as address offsets to the individual base address <FCNn_base>.

The <FCNn_base> address of each FCNn is given in Table 20-3.

Table 20-3 Register Base Addresses <FCNn_base>

FCNn Instance	<FCNn_base> Address
FCN0	FF48 0000 _H
FCN1	FF4A 0000 _H

Clock supply The following clock is input to the CAN controller.

Table 20-4 FCNn Cock Supply

FCNn	FCNn Reference Clock (f_{CAN})	Connected to
FCN0, FCN1	PCLK	Clock controller

Interrupts The interrupts of the CAN controllers are listed in Table 20-5.

Table 20-5 Interrupts of the CAN Controller

FCNn Signals	Function	Connected to
INT0ERR	FCN0 error detection	INTFCN0ERR
INT0REC	FCN0 reception completion	INTFCN0REC
INT0TRX	FCN0 transmission completion	INTFCN0TRX
INT1ERR	FCN1 error detection	INTFCN1ERR
INT1REC	FCN1 reception completion	INTFCN1REC
INT1TRX	FCN1 transmission completion	INTFCN1TRX
INT0WUP	FCN0 sleep wake-up/ transmission abortion	INTFCN0WUP
INT1WUP	FCN1 sleep wake-up/ transmission abortion	INTFCN1WUP

I/O signals The I/O signals of the CAN controllers are listed in the table below.

Table 20-6 I/O Signals of the CAN Controller

FCNn Signals	Function	Connected to
CANRXD0	FCN0 CAN bus receive input	Port FCN0RX
CANTXD0	FCN0 CAN bus transmit output	Port FCN0TX
CANRXD1	FCN1 CAN bus receive input	Port FCN1RX
CANTXD1	FCN1 CAN bus transmit output	Port FCN1TX

20.2 Features

- Compliant with ISO 11898
- Standard frame and extended frame transmission/reception enabled
- Transfer rate: 1 Mbps max.
- 32 message buffers per channel
- Receive/transmit history list function
(with enable flag for each message buffer individually)
- Automatic block transmission function
- Multi-buffer receive block function
- Mask setting of 8 patterns is possible for each channel, applicable for data and remote frames
- Data bit time, communication baud rate, and sample point can be controlled by FCN module bit-rate prescaler register (FCNnCMBRPRS) and bit-rate register (FCNnCMBTCTL)
 - As an example, the following sample-point configurations can be configured:
66.7%, 70.0%, 75.0%, 80.0%, 81.3%, 85.0%, 87.5%
 - Baud rates in the range of 10 kbps up to 1 Mbps can be configured.
- Enhanced features:
 - Each message buffer can be configured to operate as a transmit or a receive message buffer.
 - A transmission request can be aborted by clearing the dedicated transmit-request flag of the concerned message buffer. Supported by transmission abort interrupt, on successful abortion.
 - Automatic block transmission operating mode (ABT)
 - Time stamp function of FCN channels 0 and 1, collaborated with timers capture channels
 - Centralized global data new bit monitor register, collecting all data new flags to be read from one location

20.2.1 Overview of Functions

Table 20-7, Overview of Functions, presents an overview of the CAN controller functions.

Table 20-7 Overview of Functions

Function	Description
Protocol	CAN protocol ISO 11898 (standard and extended frame transmission/reception)
Baud rate	Maximum 1 Mbps (FCN's minimum reference clock input = 16 MHz)
Data storage	Storing messages in the CAN RAM
Number of messages	<ul style="list-style-type: none"> • 32 message buffers per channel • Each message buffer can be set to be either a transmit message buffer or a receive message buffer.
Message reception	<ul style="list-style-type: none"> • Unique ID can be set to each message buffer. • Mask setting of 8 patterns is possible for each channel, applicable for data and remote frames • A receive completion interrupt, which can be enabled or disabled for each message buffer, is generated every time a message is received and stored in a message buffer. • Two or more receive message buffers can be used as a FIFO receive buffer (multi-buffer receive block function). • Receive history list function, with enable flag for each message buffer individually • Centralized global data new bit monitor register
Message transmission	<ul style="list-style-type: none"> • Unique ID can be set to each message buffer. • Transmit completion interrupt can be enabled or disabled for each message buffer. • Transmission abort interrupt and transmission completion flag (only one transmission of any buffer can be aborted at a time) • Message buffer number 0 to 7 specified as the transmit message buffer can be set for automatic block transfer. Message transmission interval is programmable (automatic block transmission function (hereafter referred to as "ABT")). • Transmit history list function, with enable flag for each message buffer individually
Remote frame processing	<ul style="list-style-type: none"> • Remote frame processing by transmit message buffer • Remote frame processing by receive message buffer, when applying one of the 8 masks
Time stamp function	<ul style="list-style-type: none"> • The time stamp function can be set for a message reception when a 16-bit timer is used in combination. • Time stamp capture trigger can be selected (SOF or EOF in a CAN message frame can be detected).
Diagnostic function	<ul style="list-style-type: none"> • Readable error counters • "Valid protocol operation flag" for verification of bus connections • Receive-only mode • Single-shot mode • CAN protocol error type decoding • Self-test mode
Release from bus-off state	<ul style="list-style-type: none"> • Forced release from bus-off possible by software • No automatic release from bus-off (software must re-enable).
Power save mode	<ul style="list-style-type: none"> • CAN sleep mode (can be woken up by CAN bus) • CAN stop mode (cannot be woken up by CAN bus)

20.2.2 Configuration

The CAN controller is composed of the following four blocks.

- Peripheral bus interface
This functional block provides a peripheral bus interface and means of transmitting and receiving messages between the FCN module and the host CPU.
- MCM (Message Control Module)
This functional block controls access to the CAN protocol layer and to the CAN RAM within the FCN module.
- CAN protocol layer
This functional block is involved in the operation of the CAN protocol and its related settings.
- CAN RAM
This is the CAN memory functional block, which is used to store message IDs, message data, etc.

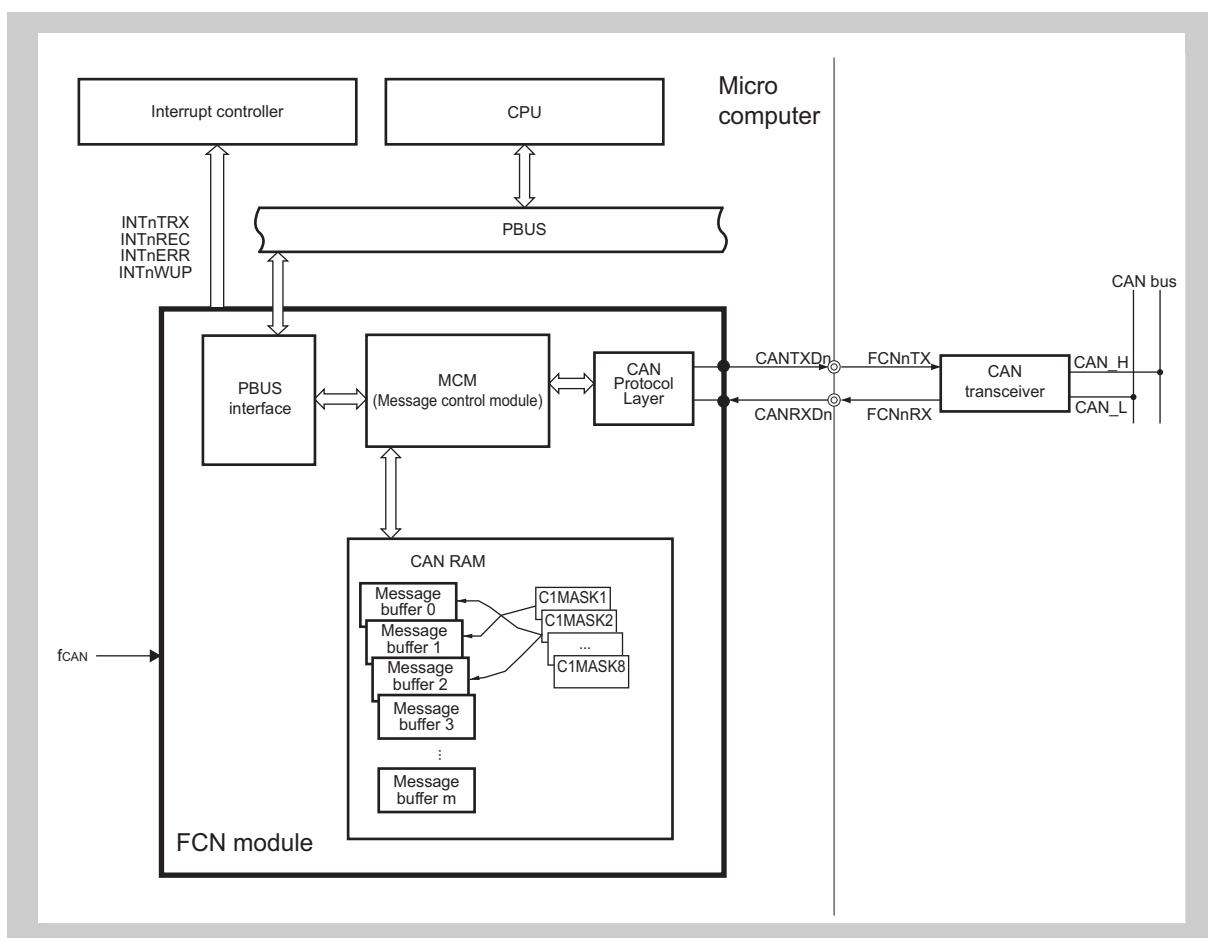

Figure 20-1 Block Diagram of the CAN Controller

20.3 Internal Registers of FCN

20.3.1 CAN Controller Configuration

Table 20-8 List of FCN Registers (1/2)

Item	Register Name
FCNn global registers	FCNn global control register (FCNnGMCLCTL)
	FCNn global clock selection register (FCNnGMCSPRE)
	FCNn global automatic block transmission control register (FCNnGMABCTL)
	FCNn global automatic block transmission delay setting register (FCNnGMADCTL)
	FCNn global data new bit monitor registers (FCNnDNBMRX0)
FCNn module registers	FCNn module mask 1 registers (FCNnCMMKCTL01H, FCNnCMMKCTL02H, FCNnCMMKCTL01W)
	FCNn module mask 2 registers (FCNnCMMKCTL03H, FCNnCMMKCTL04H, FCNnCMMKCTL03W)
	FCNn module mask 3 registers (FCNnCMMKCTL05H, FCNnCMMKCTL06H, FCNnCMMKCTL05W)
	FCNn module mask 4 registers (FCNnCMMKCTL07H, FCNnCMMKCTL08H, FCNnCMMKCTL07W)
	FCNn module mask 5 registers (FCNnCMMKCTL09H, FCNnCMMKCTL10H, FCNnCMMKCTL09W)
	FCNn module mask 6 registers (FCNnCMMKCTL11H, FCNnCMMKCTL12H, FCNnCMMKCTL11W)
	FCNn module mask 7 registers (FCNnCMMKCTL13H, FCNnCMMKCTL14H, FCNnCMMKCTL13W)
	FCNn module mask 8 registers (FCNnCMMKCTL15H, FCNnCMMKCTL16H, FCNnCMMKCTL15W)
	FCNn module control register (FCNnCMCLCTL)
	FCNn module last error information register (FCNnCMLCSTR)
	FCNn module information register (FCNnCMINSTR)
	FCNn module error counter register (FCNnCMERCNT)
	FCNn module interrupt enable register (FCNnCMIECTL)
	FCNn module interrupt status register (FCNnCMISCTL)
	FCNn module bit-rate prescaler register (FCNnCMBRPRS)
	FCNn module bit-rate register (FCNnCMBTCTL)
	FCNn module last in-pointer register (FCNnCMLISTR)
	FCNn module receive history list register (FCNnCMRGRX)
	FCNn module last out-pointer register (FCNnCMLOSTR)
	FCNn module transmit history list register (FCNnCMTGTGX)
FCNn module time stamp register (FCNnCMTSCTL)	

Table 20-8 List of FCN Registers (2/2)

Item	Register Name
FCNn message buffer registers	FCNn message data byte 0 to 3 registers m (FCNnMmDAT0W, FCNnMmDAT0H, FCNnMmDAT2H, FCNnMmDAT0B, FCNnMmDAT1B, FCNnMmDAT2B, FCNnMmDAT3B)
	FCNn message data byte 4 to 7 registers m (FCNnMmDAT4W, FCNnMmDAT4H, FCNnMmDAT6H, FCNnMmDAT4B, FCNnMmDAT5B, FCNnMmDAT6B, FCNnMmDAT7B)
	FCNn message data length register m (FCNnMmDTLGB)
	FCNn message configuration register m (FCNnMmSTRB)
	FCNn message ID registers m (FCNnMmMID0H, FCNnMmMID1H, FCNnMmMID0W)
	FCNn message control register m (FCNnMmCTL)

20.3.2 Overview of CAN Controller Registers

Note All register addresses are given as offsets to the base address <FCNn_base>. The <FCNn_base> addresses of the registers are defined in the first part of this section under the keyword "Register address".

(1) FCNn Global and Module Registers

Table 20-9 FCNn Global and Module Registers (1/2)

Address Offset	Register Name	Symbol	R/W	Access Bit	After Reset
0 0008 _H	FCNn global clock selection register	FCNnGMCSPRE	R/W	8	0F _H
0 0020 _H	FCNn global automatic block transmission delay register	FCNnGMADCTL	R/W	8	00 _H
0 8000 _H	FCNn global control register	FCNnGMCLCTL	R/W	16	00X0 _H * ¹
0 8018 _H	FCNn global automatic block transmission register	FCNnGMABCTL	R/W	16	0000 _H
1 00C0 _H	FCNn global data new bit monitor register 0	FCNnDNBMRX0	R	32	* ²
0 8300 _H	FCNn module mask 1 register	FCNnCMMKCTL01H	R/W	16	* ²
0 8308 _H		FCNnCMMKCTL02H			
1 0300 _H		FCNnCMMKCTL01W		32	
0 8310 _H	FCNn module mask 2 register	FCNnCMMKCTL03H	R/W	16	* ²
0 8318 _H		FCNnCMMKCTL04H			
1 0310 _H		FCNnCMMKCTL03W		32	
0 8320 _H	FCNn module mask 3 register	FCNnCMMKCTL05H	R/W	16	* ²
0 8328 _H		FCNnCMMKCTL06H			
1 0320 _H		FCNnCMMKCTL05W		32	
0 8330 _H	FCNn module mask 4 register	FCNnCMMKCTL07H	R/W	16	* ²
0 8338 _H		FCNnCMMKCTL08H			
1 0330 _H		FCNnCMMKCTL07W		32	
0 8340 _H	FCNn module mask 5 register	FCNnCMMKCTL09H	R/W	16	* ²
0 8348 _H		FCNnCMMKCTL10H			
1 0340 _H		FCNnCMMKCTL09W		32	

Table 20-9 FCNn Global and Module Registers (2/2)

Address Offset	Register Name	Symbol	R/W	Access Bit	After Reset
0 8350 _H	FCNn module mask 6 register	FCNnCMMKCTL11H	R/W	16	*2
0 8358 _H		FCNnCMMKCTL12H			
1 0350 _H		FCNnCMMKCTL11W		32	
0 8360 _H	FCNn module mask 7 register	FCNnCMMKCTL13H	R/W	16	*2
0 8368 _H		FCNnCMMKCTL14H			
1 0360 _H		FCNnCMMKCTL13W		32	
0 8370 _H	FCNn module mask 8 register	FCNnCMMKCTL15H	R/W	16	*2
0 8378 _H		FCNnCMMKCTL16H			
1 0370 _H		FCNnCMMKCTL15W		32	
0 0248 _H	FCNn module last error information register	FCNnCMLCSTR	R/W	8	00 _H
0 024C _H	FCNn module information register	FCNnCMINSTR	R	8	00 _H
0 0268 _H	FCNn module bit-rate prescaler register	FCNnCMBRPRS	R/W	8	FF _H
0 0278 _H	FCNn module last in-pointer register	FCNnCMLISTR	R	8	Undefined
0 0288 _H	FCNn module last out-pointer register	FCNnCMLOSTR	R	8	Undefined
0 8240 _H	FCNn module control register	FCNnCMLCTL	R/W	16	0000 _H
0 8250 _H	FCNn module error counter register	FCNnCMECNT	R	16	0000 _H
0 8258 _H	FCNn module interrupt enable register	FCNnCMICTL	R/W	16	0000 _H
0 8260 _H	FCNn module interrupt status register	FCNnCMICTL	R/W	16	0000 _H
0 8270 _H	FCNn module bit-rate register	FCNnCMBTCTL	R/W	16	370F _H
0 8280 _H	FCNn module receive history list register	FCNnCMTGRX	R/W	16	xx02 _H
0 8290 _H	FCNn module transmit history list register	FCNnCMTGTX	R/W	16	xx02 _H
0 8298 _H	FCNn module time stamp register	FCNnCMTSCTL	R/W	16	0000 _H

Note 1. The initial value depends on FCNnGMCLCTL.FCNnGMCLECCF, which indicates error detections when reading from message buffer RAM. For details, see the description on the FCNnGMCLCTL register.

Note 2. The value after a reset is 0000_H or 00000000_H.

20.3.3 Register Bit Configuration

Table 20-10 FCN Global Register Bit Configuration

Address Offset	Symbol	Bit 7/15/31/23	Bit 6/14/30/22	Bit 5/13/29/21	Bit 4/12/28/20	Bit 3/11/27/19	Bit 2/10/26/18	Bit 1/9/25/17	Bit 0/8/24/16
0 8000 _H	FCNnGMCLCTL (W)	0	0	FCNnGM CLCLMB	0	0	0	0	FCNnGMC LCLOM
		0	0	0	FCNnGM CLSESR	0	0	FCNnGM CLSEDE	FCNnGMC LSEOM
	FCNnGMCLCTL (R)	0	0	FCNnGM CLECCF	FCNnGM CLSORF	0	0	FCNnGM CLESDE	FCNnGMC LPWOM
		FCNnGM CLSSMO	0	0	0	0	0	0	0
0 0008 _H	FCNnGMCSPRE	0	0	0	0	FCNnGMCSPRSC[3:0]			
0 8018 _H	FCNnGMABCTL (W)	0	0	0	0	0	0	0	FCNnGMA BCLAT
		0	0	0	0	0	0	FCNnGM ABSEAC	FCNnGMA BSEAT
	FCNnGMABCTL (R)	0	0	0	0	0	0	FCNnGM ABCLRF	FCNnGMA BABTT
		0	0	0	0	0	0	0	0
0 0020 _H	FCNnGMADCTL	0	0	0	0	FCNnGMADSSAD[3:0]			
1 00C0 _H	FCNnDNBMRX0 (R)	FCNnDNBMSSDN[7:0]							
		FCNnDNBMSSDN[15:8]							
		FCNnDNBMSSDN[23:16]							
		FCNnDNBMSSDN[31:24]							

Table 20-11 FCN Module Mask Control 16-Bit Registers Bit Configuration (1/2)

Address Offset	Symbol	Bit 15	Bit 14	Bit 13	Bits 12 to 0
0 8300 _H	FCNnCMM KCTL01H	FCNnCMMKSSID[15:0]			
0 8308 _H	FCNnCMM KCTL02H	0	0	0	FCNnCMMKSSID[28:16]
0 8310 _H	FCNnCMM KCTL03H	FCNnCMMKSSID[15:0]			
0 8318 _H	FCNnCMM KCTL04H	0	0	0	FCNnCMMKSSID[28:16]
0 8320 _H	FCNnCMM KCTL05H	FCNnCMMKSSID[15:0]			
0 8328 _H	FCNnCMM KCTL06H	0	0	0	FCNnCMMKSSID[28:16]
0 8330 _H	FCNnCMM KCTL07H	FCNnCMMKSSID[15:0]			
0 8338 _H	FCNnCMM KCTL08H	0	0	0	FCNnCMMKSSID[28:16]
0 8340 _H	FCNnCMM KCTL09H	FCNnCMMKSSID[15:0]			
0 8348 _H	FCNnCMM KCTL10H	0	0	0	FCNnCMMKSSID[28:16]
0 8350 _H	FCNnCMM KCTL11H	FCNnCMMKSSID[15:0]			
0 8358 _H	FCNnCMM KCTL12H	0	0	0	FCNnCMMKSSID[28:16]

Table 20-11 FCN Module Mask Control 16-Bit Registers Bit Configuration (2/2)

Address Offset	Symbol	Bit 15	Bit 14	Bit 13	Bits 12 to 0
0 8360 _H	FCNnCMM KCTL13H	FCNnCMMKSSID[15:0]			
0 8368 _H	FCNnCMM KCTL14H	0	0	0	FCNnCMMKSSID[28:16]
0 8370 _H	FCNnCMM KCTL15H	FCNnCMMKSSID[15:0]			
0 8378 _H	FCNnCMM KCTL16H	0	0	0	FCNnCMMKSSID[28:16]

Table 20-12 FCN Module Mask Control 32-Bit Registers Bit Configuration

Address Offset	Symbol	Bit 31	Bit 30	Bit 29	Bits 28 to 0
1 0300 _H	FCNnCMM KCTL01W	0	0	0	FCNnCMMKSSID[28:0]
1 0310 _H	FCNnCMM KCTL03W	0	0	0	FCNnCMMKSSID[28:0]
1 0320 _H	FCNnCMM KCTL05W	0	0	0	FCNnCMMKSSID[28:0]
1 0330 _H	FCNnCMM KCTL07W	0	0	0	FCNnCMMKSSID[28:0]
1 0340 _H	FCNnCMM KCTL09W	0	0	0	FCNnCMMKSSID[28:0]
1 0350 _H	FCNnCMM KCTL11W	0	0	0	FCNnCMMKSSID[28:0]
1 0360 _H	FCNnCMM KCTL13W	0	0	0	FCNnCMMKSSID[28:0]
1 0370 _H	FCNnCMM KCTL15W	0	0	0	FCNnCMMKSSID[28:0]

Table 20-13 FCN Module Register Bit Configuration (1/2)

Address Offset	Symbol	Bit 7/15	Bit 6/14	Bit 5/13	Bit 4/12	Bit 3/11	Bit 2/10	Bit 1/9	Bit 0/8
0 8240 _H	FCNnCM CLCTL (W)	0	FCNnCM CLCLAL	FCNnCM CLCLVL	FCNnCMCLCLPS[1:0]		FCNnCMCLCLOP[2:0]		
		FCNnCM CLSERC	FCNnCM CLSEAL	0	FCNnCMCLSEPS[1:0]		FCNnCMCLSEOP[2:0]		
	FCNnCM CLCTL (R)	FCNnCM CLERCF	FCNnCM CLALBF	FCNnCM CLVALF	FCNnCMCLMDPF [1:0]		FCNnCMCLMDOF[2:0]		
		0	0	0	0	0	0	FCNnCM CLSSRS	FCNnCM CLSSTS
0 0248 _H	FCNnCM LCSTR (W)	0	0	0	0	0	0	0	0
	FCNnCM LCSTR (R)	0	0	0	0	0	FCNnCMCLSSL2[2:0]		
0 024CH	FCNnCM INSTR	0	0	0	FCNnCMI NBOFF	FCNnCMINSSTE[1:0]		FCNnCMINSSRE[1:0]	
0 8250 _H	FCNnCM ERCNT	FCNnCMERTECF[7:0]							
		FCNnCM ERRPSF	FCNnCMERRECF[6:0]						
0 8258 _H	FCNnCM IECTL (W)	0	FCNnCMIECLIE[6:0]						
		0	FCNnCMIESEIE[6:0]						
	FCNnCM IECTL (R)	0	FCNnCMIEINTF[6:0]						
		0	0	0	0	0	0	0	0
0 8260 _H	FCNnCM ISCTL (W)	0	FCNnCMISCLTS[6:0]						
		0	0	0	0	0	0	0	0
	FCNnCM ISCTL (R)	0	FCNnCMISITSF[6:0]						
		0	0	0	0	0	0	0	0
0 0268 _H	FCNnCM BRPRS	FCNnCMBRPRS[7:0]							
0 8270 _H	FCNnCM BTCTL	0	0	0	0	FCNnCMBTS1LG[3:0]			
		0	0	FCNnCMBTJWLG [1:0]		0	FCNnCMBTS2LG[2:0]		
0 0278 _H	FCNnCM LISTR	FCNnCMLISSLR[7:0]							
0 8280 _H	FCNnCM RGRX (W)	0	0	0	0	0	0	0	FCNnCM RGCLRV
		0	0	0	0	0	0	0	0
	FCNnCM RGRX (R)	0	0	0	0	0	0	FCNnCM RGSSPM	FCNnCM RGRVFF
		FCNnCMRDSSPT[7:0]							
0 0288 _H	FCNnCM LOSTR	FCNnCMLOSSLT[7:0]							
0 8290 _H	FCNnCM TGTX (W)	0	0	0	0	0	0	0	FCNnCM TGCLTV
		0	0	0	0	0	0	0	0
	FCNnCM TGTX (R)	0	0	0	0	0	0	FCNnCM TGSSPM	FCNnCM TGTVFF
		FCNnCMTGSSPT[7:0]							

Table 20-13 FCN Module Register Bit Configuration (2/2)

Address Offset	Symbol	Bit 7/15	Bit 6/14	Bit 5/13	Bit 4/12	Bit 3/11	Bit 2/10	Bit 1/9	Bit 0/8
0 8298 _H	FCNnCM TSCTL (W)	0	0	0	0	0	FCNnCM TSCLK	FCNnCM TSCLSL	FCNnCM TSCLTS
		0	0	0	0	0	FCNnCM TSSELK	FCNnCM TSSESL	FCNnCM TSSETS
	FCNnCM TSCTL (R)	0	0	0	0	0	FCNnCM TSLOKE	FCNnCM TSSELE	FCNnCM TSTSGE
		0	0	0	0	0	0	0	0

Table 20-14 FCN Message Buffer Register Bit Configuration (1/2)

Address Offset	Symbol	Bit 7/15/ 31/23	Bit 6/14/ 30/22	Bit 5/13/ 29/21	Bit 4/12/ 28/20	Bit 3/11/ 27/19	Bit 2/10/ 26/18	Bit 1/9/ 25/17	Bit 0/8/ 24/16	
1 1000 _H + m × 40 _H	FCNnMm DAT0W	FCNnMmSSD0[7:00]								
		FCNnMmSSD1[7:00]								
		FCNnMmSSD2[7:00]								
		FCNnMmSSD3[7:00]								
0 9000 _H + m × 40 _H	FCNnMm DAT0H	FCNnMmSSD0[7:00]								
		FCNnMmSSD1[7:00]								
0 1000 _H + m × 40 _H	FCNnMm DAT0B	FCNnMmSSD0[7:00]								
0 1004 _H + m × 40 _H	FCNnMm DAT1B	FCNnMmSSD1[7:00]								
		FCNnMmSSD2[7:00]								
0 9008 _H + m × 40 _H	FCNnMm DAT2H	FCNnMmSSD2[7:00]								
		FCNnMmSSD3[7:00]								
0 1008 _H + m × 40 _H	FCNnMm DAT2B	FCNnMmSSD2[7:00]								
0 100C _H + m × 40 _H	FCNnMm DAT3B	FCNnMmSSD3[7:00]								
1 1010 _H + m × 40 _H	FCNnMm DAT4W	FCNnMmSSD4[7:00]								
		FCNnMmSSD5[7:00]								
		FCNnMmSSD6[7:00]								
		FCNnMmSSD7[7:00]								
0 9010 _H + m × 40 _H	FCNnMm DAT4H	FCNnMmSSD4[7:00]								
		FCNnMmSSD5[7:00]								
0 1010 _H + m × 40 _H	FCNnMm DAT4B	FCNnMmSSD4[7:00]								
0 1014 _H + m × 40 _H	FCNnMm DAT5B	FCNnMmSSD5[7:00]								
0 9018 _H + m × 40 _H	FCNnMm DAT6H	FCNnMmSSD6[7:00]								
		FCNnMmSSD7[7:00]								
0 1018 _H + m × 40 _H	FCNnMm DAT6B	FCNnMmSSD6[7:00]								
0 101C _H + m × 40 _H	FCNnMm DAT7B	FCNnMmSSD7[7:00]								
0 1020 _H + m × 40 _H	FCNnMm DTLGB	0				FCNnMmDTLG[3:0]				
0 1024 _H + m × 40 _H	FCNnMm STRB	FCNnMm SSOW	FCNnMmSSMT[3:0]				FCNnMm SSRT	0	FCNnMm SSAM	

Table 20-14 FCN Message Buffer Register Bit Configuration (2/2)

Address Offset	Symbol	Bit 7/15/ 31/23	Bit 6/14/ 30/22	Bit 5/13/ 29/21	Bit 4/12/ 28/20	Bit 3/11/ 27/19	Bit 2/10/ 26/18	Bit 1/9/ 25/17	Bit 0/8/ 24/16
0 9028 _H + m × 40 _H	FCNnMm MID0H	FCNnMmSSID[7:0]							
		FCNnMmSSID[15:8]							
0 9030 _H + m × 40 _H	FCNnMm MID1H	FCNnMmSSID[23:16]							
		FCNnMm SSIE	0	0	FCNnMmSSID[28:24]				
1 1028 _H + m × 40 _H	FCNnMm MID0W	FCNnMmSSID[7:0]							
		FCNnMmSSID[15:8]							
		FCNnMmSSID[23:16]							
		FCNnMm SSIE	0	0	FCNnMmSSID[28:24]				
0 9038 _H + m × 40 _H	FCNnMmCTL (W)	0	FCNnMm CLNH	0	FCNnMm CLMW	FCNnMm CLIE	FCNnMm CLDN	FCNnMm CLTR	FCNnMm CLRY
		0	FCNnMm SENH	0	0	FCNnMm SEIE	0	FCNnMm CSETR	FCNnMm SERY
	FCNnMmCTL (R)	0	FCNnMm NHMF	0	FCNnMm MOWF	FCNnMm IENF	FCNnMm DTNF	FCNnMm TRQF	FCNnMm RDYF
		0	0	FCNnMm MUCF	0	0	0	FCNnMm TCPF	0

20.4 Bit Set/Clear Functions

The FCN control registers include registers whose bits can be set or cleared via the CPU and via the CAN controller. These register bits cannot be changed directly by the CPU by any bit manipulation instructions, such as SET1, CLR1, and NOT1. Instead, a special bit-set/bit-clear mechanism is used.

All registers where bit manipulation operations are prohibited are organized in such a way that all bits allowed for changing by the CPU are located in the lower byte (RWx in the register layout below), while in the upper byte either no or read-only information is located (ROx in the register layout below).

The registers can be read in the usual way getting all 16 data bits in their current setting, as described in the register description.

For setting or clearing any of the lower 8 bits, the following mechanism is implemented:

When writing 16-bit data to the register address,

- Bit clear**
- Each of the lower 8 data bits (CLx in the register layout below) indicates whether the corresponding register bit RWx should be
 - cleared, i.e. set to 0: if CLx = 1, the corresponding RWx is cleared to 0
 - remain unchanged: if CLx = 0, the corresponding RWx does not change
- Bit set**
- Each of the upper 8 data bits (SEx in the register layout below) indicates whether the corresponding register bit should be
 - set, i.e. set to 1: if SEx = 1, the corresponding RWx is set to 1
 - remain unchanged: if SEx = 0, the corresponding RWx does not change

Register layout for read access:

15	14	13	12	11	10	9	8	7	6	5	4	3	2	1	0
RO7	RO6	RO5	RO4	RO3	RO2	RO1	RO0	RW7	RW6	RW5	RW4	RW3	RW2	RW1	RW0
Changing by the CPU not possible								Bits for CPU manipulation via SE7 to SE0 and CL7 to CL0							

Register layout for write access:

15	14	13	12	11	10	9	8	7	6	5	4	3	2	1	0
SE7	SE6	SE5	SE4	SE3	SE2	SE1	SE0	CL7	CL6	CL5	CL4	CL3	CL2	CL1	CL0
SEx = 1 sets the corresponding RW7 to RW0								CLx = 1 clears the corresponding RW7 to RW0							

The following table denotes the operations applied to the RWx bits.

Table 20-15 Bit Set/Clear Operation

CLx	SEx	Operation on RWx
0	0	No change of RWx
0	1	RWx set to 1
1	0	RWx cleared to 0
1	1	No change of RWx

Example The following shows an example.

The register with the content 1883_H shall be changed so that

- bit 3 shall be set to 1: SE3 = 1
- bit 1 shall be cleared to 0: CL1 = 1

Register read before bit manipulations:

15	14	13	12	11	10	9	8	7	6	5	4	3	2	1	0
0	0	0	1	1	0	0	0	1	0	0	0	0	0	1	1
May hold any value, here 18 _H								RW7 to RW0: 83 _H							

Register write access:

15	14	13	12	11	10	9	8	7	6	5	4	3	2	1	0
0	0	0	0	1	0	0	0	0	0	0	0	0	0	1	0
SE3 = 1: 08 _H								CL1 = 1: 02 _H							

Register read after bit manipulations:

15	14	13	12	11	10	9	8	7	6	5	4	3	2	1	0
0	0	0	1	1	0	0	0	1	0	0	0	1	0	0	1
May hold any value, here 18 _H								RW7 to RW0: 89 _H							

20.5 Control Registers

20.5.1 FCN Global Registers

(1) FCNnGMCLCTL - FCNn Global Control Register

This register is used to control the operation of the FCN module.

Access This register can be read/written in 16-bit units.

Address <FCNn_base> + 0 8000_H

Initial value 00x0_H

This register is initialized by various types of reset.

(a) FCNnGMCLCTL Read

	15	14	13	12	11	10	9	8
FCNnGM CLSSMO	0	0	0	0	0	0	0	0
	7	6	5	4	3	2	1	0
0	0	FCNnGMC LECCF *1	FCNnGMC LSORF*1	0	0	FCNnGM CLESDE	FCNnGM CLPWOM	

Note 1. Initial values are as follows:

- No error detection after software reset: 0000_H
- No error detection during software reset: 0010_H
- Error detection after software reset: 0020_H
- Error detection during software reset: 0030_H

FCNnGMCLSSMO	Enabling Access to Message Buffer Register and Transmit/Receive History Registers of FCN Module
0	Write access and read access to the message buffer register and the transmit/receive history list registers is disabled.
1	Write access and read access to the message buffer register and the transmit/receive history list registers is enabled.

Caution 1. While FCNnGMCLCTL.FCNnGMCLSSMO is cleared to 0, software access to the message buffer registers (i.e. all registers with name prefix FCNnMm...), or registers related to transmit history or receive history (FCNnCMLOSTR, FCNnCMTGTX, FCNnCMLISTR, and FCNnCMRGRX) is disabled.

Caution 2. FCNnGMCLCTL.FCNnGMCLSSMO is read-only. Even if 1 is written while it is 0, its value does not change, and access to the message buffer registers, or registers related to transmit history or receive history remains disabled.

Note FCNnGMCLCTL.FCNnGMCLSSMO is cleared to 0 when the FCN module enters FCN sleep mode/FCN stop mode, or when FCNnGMCLCTL.FCNnGMCLPWOM is cleared to 0.

FCNnGMCLSSMO is set to 1 when FCN sleep mode/FCN stop mode is released, or when FCNnGMCLCTL.FCNnGMCLPWOM is set to 1.

FCNnGMCLECCF	Message Buffer RAM Read Error Detect
0	Not detect error for reading from message buffer RAM.
1	Detect error for reading from message buffer RAM.

Note 1. FCNnGMCLCTL.FCNnGMCLECCF is set to 1 in case of detecting a memory error when reading from the message buffer RAM during the software reset process. Once FCNnGMCLECCF is set to 1, it keeps the level until it is cleared to 0.

Note 2. Use this bit only to check a memory error after software reset.

Note 3. It is impossible to clear FCNnGMCLECCF to 0 while FCNnGMCLCTL.FCNnGMCLSORF is set to 1 (software reset is ongoing).

FCNnGMCLSORF	Software Reset Execution Status
0	No software reset
1	Software reset is ongoing

Note 1. While a software reset is ongoing (FCNnGMCLCTL.FCNnGMCLSORF is set to 1), it is impossible to set FCNnGMCLCTL.FCNnGMCLPWOM and FCNnGMCLCTL.FCNnGMCLESEDE.

It is possible to set start a software reset by setting FCNnGMCLCTL.FCNnGMCLSESR to 1 while FCNnGMCLCTL.FCNnGMCLPWOM is cleared to 0.

Note 2. When FCNnGMCLCTL.FCNnGMCLSORF is set to 1, the initialization of message buffer RAM starts. It is possible to detect error during initializing message buffer RAM, if FCNnGMCLCTL.FCNnGMCLECCF is cleared before setting FCNnGMCLSORF.

Note 3. When FCNnGMCLCTL.FCNnGMCLSORF is set to 1 again while it has been set to 1, the software reset procedure does not restart, but continues.

Note 4. After release of the hardware reset, FCNnGMCLCTL.FCNnGMCLSORF is automatically set to 1 and initialization of message buffer RAM starts.

Note 5. It is impossible that clearing FCNnGMCLCTL.FCNnGMCLPWOM to 0 and setting FCNnGMCLCTL.FCNnGMCLSORF to 1 are done at the same time.

Note 6. If a hardware reset occurs while FCNnGMCLCTL.FCNnGMCLSORF = 1, the software reset procedure is stopped (aborted), and the hardware reset starts.

FCNnGMCLESEDE	Enabling Forced Shut Down
0	Forced shut down disabled.
1	Forced shut down of FCNnGMCLCTL.FCNnGMCLPWOM bit = 0 enabled.

Caution To request a forced shut down, FCNnGMCLCTL.FCNnGMCLPWOM must be cleared to 0 in a sub-sequent, immediately following access after FCNnGMCLCTL.FCNnGMCLESEDE has been set to 1. If any access to another register (including reading the FCNnGMCLCTL register) is executed without clearing FCNnGMCLPWOM immediately after FCNnGMCLESEDE has been set to 1, FCNnGMCLESEDE is forcibly cleared to 0, and the forced shut down request is invalid.

FCNnGMCLPWOM	Global Operating Mode
0	FCN module is disabled to operate.
1	FCN module is enabled to operate.

Caution FCNnGMCLCTL.FCNnGMCLPWOM can be cleared only in initialization mode or immediately after FCNnGMCLCTL.FCNnGMCLESD is set (forced shut down).

(b) FCNnGMCLCTL Write

15	14	13	12	11	10	9	8
0	0	0	FCNnGM CLSESR	0	0	FCNnGM CLSESD	FCNnGM CLSEOM
7	6	5	4	3	2	1	0
0	0	FCNnGM CLCLMB	0	0	0	0	FCNnGM CLCLOM

FCNnGMCLSESR	Software Reset Start
0	No changes.
1	Start software reset.

FCNnGMCLSESD	FCNnGMCLSESD Setting
0	FCNnGMCLESD bit remains unchanged.
1	FCNnGMCLESD bit set to 1.

FCNnGMCLSEOM	FCNnGMCLCLOM	FCNnGMCLPWOM Setting
0	1	FCNnGMCLCTL.FCNnGMCLPWOM bit cleared to 0.
1	0	FCNnGMCLCTL.FCNnGMCLPWOM bit set to 1.
Other than the above		FCNnGMCLCTL.FCNnGMCLPWOM bit remains unchanged.

Caution Set FCNnGMCLCTL.FCNnGMCLPWOM and FCNnGMCLCTL.FCNnGMCLESD bits always separately.

FCNnGMCLCLMB	FCNnGMCLCTL.FCNnGMCLECCF Clear
0	No change in FCNnGMCLCTL.FCNnGMCLECCF bit.
1	FCNnGMCLCTL.FCNnGMCLECCF bit cleared to 0.

(2) FCNnGMCSPRE - FCNn Global Clock Selection Register

This register is used to select the FCN module system clock.

Access This register can be read/written in 8-bit units.

Address <FCNn_base> + 0008_H

Initial value 0F_H

This register is initialized by various types of reset.

7	6	5	4	3	2	1	0
0	0	0	0	FCNnGMCSPRSC[3:0]			

FCNnGMCSPRSC[3:0]	FCN Module System Clock (f_{CANMOD})
0000 _B	$f_{CAN}/1$
0001 _B	$f_{CAN}/2$
0010 _B	$f_{CAN}/3$
0011 _B	$f_{CAN}/4$
0100 _B	$f_{CAN}/5$
0101 _B	$f_{CAN}/6$
0110 _B	$f_{CAN}/7$
0111 _B	$f_{CAN}/8$
1000 _B	$f_{CAN}/9$
1001 _B	$f_{CAN}/10$
1010 _B	$f_{CAN}/11$
1011 _B	$f_{CAN}/12$
1100 _B	$f_{CAN}/13$
1101 _B	$f_{CAN}/14$
1110 _B	$f_{CAN}/15$
1111 _B	$f_{CAN}/16$ (default value)

Note f_{CAN} = FCN reference clock

(3) FCNnGMABCTL - FCNn Global Automatic Block Transmission Control Register

This register is used to control the automatic block transmission (ABT) operation.

Access This register can be read/written in 16-bit units.

Address <FCNn_base> + 0 8018_H

Initial value 0000_H

This register is initialized by various types of reset.

(a) FCNnGMABCTL Read

15	14	13	12	11	10	9	8
0	0	0	0	0	0	0	0
7	6	5	4	3	2	1	0
0	0	0	0	0	0	FCNnGM ABCLRF	FCNnGM ABABTT

FCNnGMABCLRF	Automatic Block Transmission Engine Clear Status
0	Clearing the automatic transmission engine is completed.
1	The automatic transmission engine is being cleared.

Note Start clearing the automatic transmission engine by setting FCNnGMABCTL.FCNnGMABSEAC to 1 while FCNnGMABCTL.FCNnGMABABTT is 0. The operation is not guaranteed if FCNnGMABCLRF is set to 1 while FCNnGMABABTT = 1.

FCNnGMABABTT	Automatic Block Transmission Status
0	Automatic block transmission is stopped.
1	Automatic block transmission is under execution.

(b) FCNnGMABCTL Write

15	14	13	12	11	10	9	8
0	0	0	0	0	0	FCNnGM ABSEAC	FCNnGM ABSEAT
7	6	5	4	3	2	1	0
0	0	0	0	0	0	0	FCNnGM ABCLAT

Note When the automatic block transmission engine is cleared by setting FCNnGMABCTL.FCNnGMABSEAC to 1, FCNnGMABCLRF is automatically set, and cleared to 0 as soon as the requested clearing processing is completed.

- Caution 1.** Before changing normal operating mode with ABT to initialization mode, be sure to set the FCNnGMABCTL register to the default value (0000_H) and confirm the FCNnGMABCTL register is surely initialized to the default value (0000_H).
- Caution 2.** Do not start automatic block transmission in initialization mode. If automatic block transmission is started in initialization mode, the operation is not guaranteed after the CAN controller has entered normal operating mode with ABT.
- Caution 3.** Do not start automatic block transmission while FCNnCMCLCTL.FCNnCMCLSSTS is set to 1 (transmission in progress). Confirm FCNnCMCLSSTS = 0 directly in advance before starting automatic block transmission.

FCNnGMABSEAC	Automatic Block Transmission Engine Clear Request
0	The automatic block transmission engine is in idle status or under operation.
1	Request to clear the automatic block transmission engine. After the automatic block transmission engine has been cleared, automatic block transmission is started from message buffer 0 by setting FCNnGMABCTL.FCNnGMABABTT to 1.

FCNnGMABSEAT	FCNnGMABCLAT	Automatic Block Transmission Start
0	1	Request to stop automatic block transmission.
1	0	Request to start automatic block transmission.
Other than the above		No change of FCNnGMABCTL.FCNnGMABABTT

(4) FCNnGMADCTL - FCNn Global Automatic Block Transmission Delay Register

This register is used to set the interval at which the data of the message buffer assigned to ABT is to be transmitted in normal operating mode with ABT.

Access This register can be read/written in 8-bit units.

Address <FCNn_base> + 0020_H

Initial value 00_H

This register is initialized by various types of reset.

7	6	5	4	3	2	1	0
0	0	0	0	FCNnGMADSSAD[3:0]			

FCNnGMADSSAD[3:0]	Data Frame Interval during Automatic Block Transmission in DBT Unit* ¹
0000 _B	0 DBT (default value)
0001 _B	2 ⁵ DBT
0010 _B	2 ⁶ DBT
0011 _B	2 ⁷ DBT
0100 _B	2 ⁸ DBT
0101 _B	2 ⁹ DBT
0110 _B	2 ¹⁰ DBT
0111 _B	2 ¹¹ DBT
1000 _B	2 ¹² DBT
Other than the above	Setting prohibited

Note 1. Unit: Data bit time (DBT)

-
- Caution 1. Do not change the contents of the FCNnGMADCTL register while FCNnGMABCTL.FCNnGMABCLRF = 1 (clearing of ABT in progress).
- Caution 2. The timing at which the ABT message is actually transmitted onto the CAN bus differs depending on the status of transmission from the other station or how a request to transmit a message other than an ABT message is made.
-

(5) FCNnDNBMRXk - FCNn Global Data New Bit Monitor Registers (k = 0, 1)

These registers are used to read data new flags globally for several message buffers at a time.

Access These registers can be read in 32-bit units.

Address FCNnDNBMRX0: <FCNn_base> + 1 00C0_H

Initial value 0000 0000_H

This register can be initialized by various reset operations.

(a) FCNnDNBMRX0

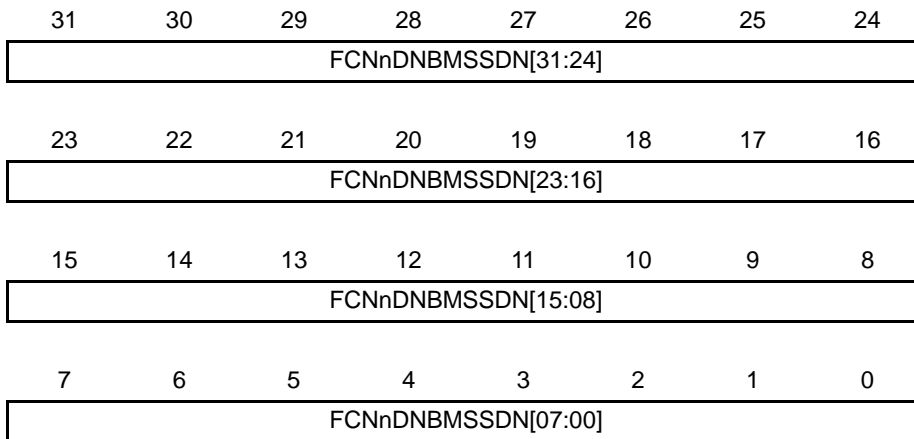

FCNnDNBMSSDN[31:0]	Message Buffer Data New
0	No remote or data frame has been stored into the message buffer.
1	A remote or data frame has been stored into the message buffer.

20.5.2 FCN Module Registers

(1) FCNnCMMKCTLaH - FCNn Module Mask Control Register

These registers are used to extend the number of receivable messages into the same message buffer by masking part of the identifier (ID) comparison of a message and invalidating the ID of the masked part.

Two 16-bit registers FCNnCMMKCTLaH (a = 01 to 16) can also be accessed via a single 32-bit access to the registers FCNnCMMKCTLaW (a = 01, 03, 05, 07, 09, 11, 13, 15).

Access The FCNnCMMKCTLaH registers can be read/written in 16-bit units.
The FCNnCMMKCTLaW registers can be read/written in 32-bit units.

Address FCNnCMMKCTL01H: <FCNn_base> + 0 8300_H
 FCNnCMMKCTL02H: <FCNn_base> + 0 8308_H
 FCNnCMMKCTL03H: <FCNn_base> + 0 8310_H
 FCNnCMMKCTL04H: <FCNn_base> + 0 8318_H
 FCNnCMMKCTL05H: <FCNn_base> + 0 8320_H
 FCNnCMMKCTL06H: <FCNn_base> + 0 8328_H
 FCNnCMMKCTL07H: <FCNn_base> + 0 8330_H
 FCNnCMMKCTL08H: <FCNn_base> + 0 8338_H
 FCNnCMMKCTL09H: <FCNn_base> + 0 8340_H
 FCNnCMMKCTL10H: <FCNn_base> + 0 8348_H
 FCNnCMMKCTL11H: <FCNn_base> + 0 8350_H
 FCNnCMMKCTL12H: <FCNn_base> + 0 8358_H
 FCNnCMMKCTL13H: <FCNn_base> + 0 8360_H
 FCNnCMMKCTL14H: <FCNn_base> + 0 8368_H
 FCNnCMMKCTL15H: <FCNn_base> + 0 8370_H
 FCNnCMMKCTL16H: <FCNn_base> + 0 8378_H

FCNnCMMKCTL01W: <FCNn_base> + 1 0300_H
 FCNnCMMKCTL03W: <FCNn_base> + 1 0310_H
 FCNnCMMKCTL05W: <FCNn_base> + 1 0320_H
 FCNnCMMKCTL07W: <FCNn_base> + 1 0330_H
 FCNnCMMKCTL09W: <FCNn_base> + 1 0340_H
 FCNnCMMKCTL11W: <FCNn_base> + 1 0350_H
 FCNnCMMKCTL13W: <FCNn_base> + 1 0360_H
 FCNnCMMKCTL15W: <FCNn_base> + 1 0370_H

Initial value FCNnCMMKCTLaH 0000_H
 FCNnCMMKCTLaW 0000 0000_H

This register can be initialized by various reset operations.

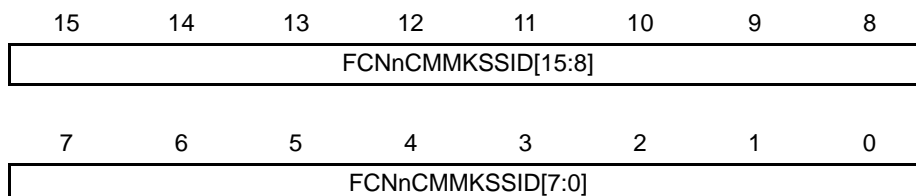

(a) FCNnCMMKCTLaH (a = 01, 03, 05, 07, 09, 11, 13, 15)

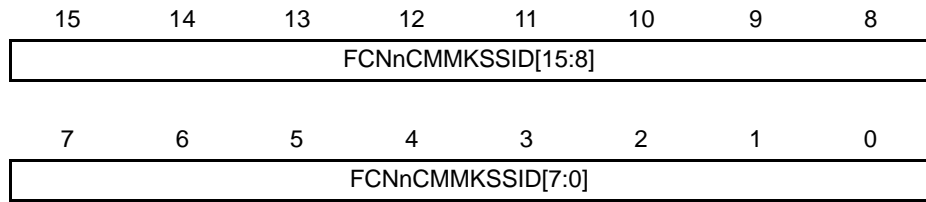

(b) FCNnCMMKCTLaH (a = 02, 04, 06, 08, 10, 12, 14, 16)

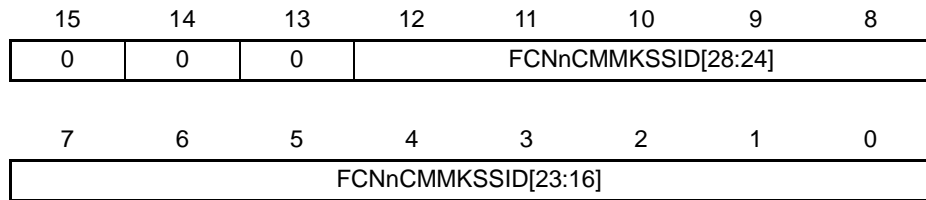

(c) FCNnCMMKCTLaW (a = 01, 03, 05, 07, 09, 11, 13, 15)

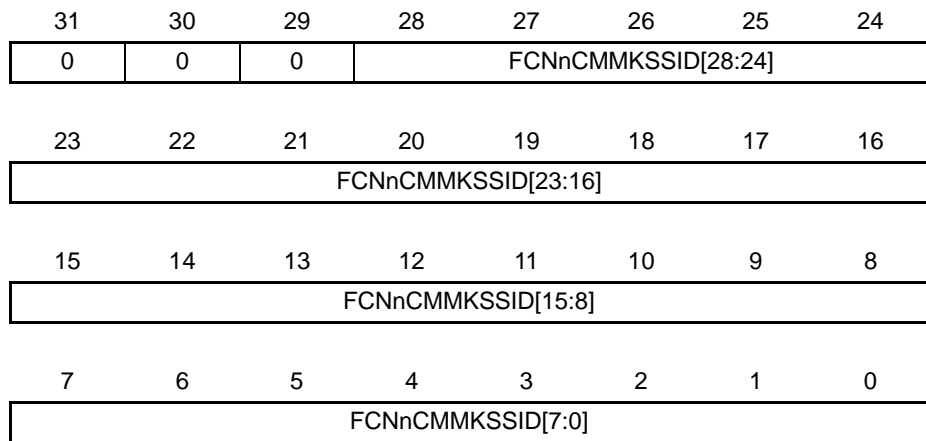

FCNnCMMKSSID[i] *1	Mask Pattern Setting of ID
0	The ID bit i of the message buffer m set by FCNnMmSSID[i] are compared with the ID bits of the received message frame.
1	The ID bit i of the message buffer m set by FCNnMmSSID[i] are not compared with the ID bits of the received message frame (they are masked).

Note 1. i = [28:0]

Note Masking is always defined by an ID length of 29 bits. If a mask is assigned to a message with a standard ID, FCNnCMMKSSID[17:0] are ignored. Therefore, only FCNnCMMKSSID[28:18] of the received ID are masked. The same mask can be used for both the standard and extended IDs.

(2) FCNnCMCLCTL - FCNn Module Control Register

This register is used to control operating mode of the FCN module.

Access This register can be read/written in 16-bit units.

Address <FCNn_base> + 0 8240_H

Initial value 0000_H

This register is initialized by various types of reset.

(a) FCNnCMCLCTL Read

15	14	13	12	11	10	9	8
0	0	0	0	0	0	FCNnCM CLSSRS	FCNnCM CLSSTS

7	6	5	4	3	2	1	0
FCNnCM CLERCF	FCNnCM CLALBF	FCNnCM CLVALF	FCNnCM CLMDPF[1:0]		FCNnCM CLMDOF[2:0]		

FCNnCMCLSSRS	Reception Status
0	Reception is stopped.
1	Reception is in progress.

Note 1. FCNnCMCLSSRS is set to 1 under the following conditions (timing).

- The SOF bit of a receive frame is detected
- On occurrence of arbitration loss during a transmit frame

Note 2. FCNnCMCLSSRS is cleared to 0 under the following conditions (timing).

- When a recessive level is detected at the second bit of the inter-frame space
- On transition to initialization mode at the first bit of the inter-frame space

FCNnCMCLSSTS	Transmission Status
0	Transmission is stopped.
1	Transmission is in progress.

Note 1. FCNnCMCLSSTS is set to 1 under the following condition (timing).

- The SOF bit of a transmit frame is detected

Note 2. FCNnCMCLSSTS is cleared to 0 under the following conditions (timing).

- During transition to bus-off state
- On occurrence of arbitration loss in transmit frame
- On detection of recessive level at the second bit of the inter-frame space
- On transition to initialization mode at the first bit of the inter-frame space

FCNnCMCLERCF	Error Counter Clear
0	The FCNnCMERCNT and FCNnCMINSTR registers are not cleared in initialization mode.
1	The FCNnCMERCNT and FCNnCMINSTR registers are cleared in initialization mode.

Caution The FCNnCMCLERCF bit is used to clear the error counter FCNnCMERCNT and information register FCNnCMINSTR for re-initialization or forced recovery from the bus-off state. The error counter and the information register can be cleared (by setting FCNnCMCLERCF to 1) under the following conditions.

- In initialization mode during bus-off period
- In initialization mode after the FCN module is started (by setting FCNnGMCLPWOM to 1 from the FCNnGMCLPWOM = 0 state)
- In initialization mode after all transmission requests are cleared according to the transmission abort processing in Figure 20-24 in operating mode (In normal operating mode with ABT, clear all transmission requests according to the transmission abort processing in Figure 20-25.)

- Note 1. When the FCNnCMERCNT and FCNnCMINSTR registers have been cleared, FCNnCMCLERCF is also cleared to 0 automatically.
- Note 2. FCNnCMCLERCF can be set to 1 at the same time as a request to change initialization mode to an operating mode is made.
- Note 3. FCNnCMCLERCF is read-only in FCN sleep mode or FCN stop mode.
- Note 4. The error counter is also cleared by normal shutdown or forced shutdown of the CAN controller.

FCNnCMCLALBF	Setting Operation in Case of Arbitration Loss
0	Re-transmission is not executed in case of an arbitration loss in single-shot mode.
1	Re-transmission is executed in case of an arbitration loss in single-shot mode.

Note FCNnCMCLALBF is valid only in single-shot mode.

FCNnCMCLVALF	Valid Receive Message Frame Detection
0	A valid message frame has not been received since FCNnCMCLVALF was last cleared to 0.
1	A valid message frame has been received since FCNnCMCLVALF was last cleared to 0.

- Note 1. Detection of a valid receive message frame is not dependent upon storage in the receive message buffer (data frame) or transmit message buffer (remote frame).
- Note 2. If only two CAN nodes are connected to the CAN bus with one transmitting a message frame in normal mode and the other in receive-only mode, FCNnCMCLVALF is not set to 1 before the transmitting node enters the error passive state, because in receive-only mode no acknowledge is generated.
- Note 3. To clear FCNnCMCLVALF, set FCNnCMCLLVL to 1 first and confirm that FCNnCMCLVALF is cleared. If it is not cleared, perform clearing processing again.

FCNnCMCLMDPF[1:0]	Power Save Mode
00 _B	No power save mode is selected.
01 _B	FCN sleep mode
10 _B	Setting prohibited
11 _B	FCN stop mode

- Caution 1. Transition to and from FCN stop mode must be made via FCN sleep mode. A request for direct transition to and from FCN stop mode is ignored.
- Caution 2. The FCNnGMCLSSMO flag of FCNnGMCLCTL must be checked after releasing a power save mode prior to access the message buffers again.
- Caution 3. FCN sleep mode requests are kept pending, until cancelled by software or entered on appropriate bus condition (bus idle). Software can check the actual status by reading FCNnCMCLMDPF[1:0].
- Caution 4. Do not use power save mode in combination with the operating mode change. Make these accesses in different steps.

Note When initialization mode transitions to any communication mode, the FCN module checks the CAN bus idle period and then participates in communication. The FCN module can transition to sleep mode before checking the idle period, but the wake-up condition is always a change from recessive level to dominant level.

FCNnCMCLMDOF[2:0]	Operating Mode
000 _B	No operating mode is selected (FCN module is in initialization mode).
001 _B	Normal operating mode
010 _B	Normal operating mode with automatic block transmission function (normal operating mode with ABT)
011 _B	Receive-only mode
100 _B	Single-shot mode
101 _B	Self-test mode
Other than above	Setting prohibited

- Caution 1. Transition to initialization mode or power save mode may take some time. Be sure to verify the success of mode change by reading the values, before proceeding.
- Caution 2. If initialization mode is set during reception in operating mode, the last reception in which the FCNnMmCTL.FCNnMmDTNF bit in the message buffer is set may occur. A transition back to operating mode also clears the receive history list. Therefore, confirm that initialization mode is reached by reading operating mode. Before restarting operating mode, clear all set FCNnMmCTL.FCNnMmDTNF bits in all valid receive message buffer.

Note FCNnCMCLMDOF[2:0] are read-only in FCN sleep mode or FCN stop mode.

(b) FCNnCMCLCTL Write

15	14	13	12	11	10	9	8
FCNnCM CLSERC	FCNnCM CLSEAL	0	FCNnCM CLSEPS[1:0]		FCNnCM CLSEOP[2:0]		

7	6	5	4	3	2	1	0
0	FCNnCM CLCLAL	FCNnCM CLCLVL	FCNnCM CLCLPS[1:0]		FCNnCM CLCLOP[2:0]		

FCNnCMCLSERC	Setting FCNnCMCLERCF
1	FCNnCMCLERCF is set to 1.
Other than above	FCNnCMCLERCF is not changed.

FCNnCMCLSEAL	FCNnCMCLCLAL	Setting FCNnCMCLALBF
0	1	FCNnCMCLALBF is cleared to 0.
1	0	FCNnCMCLALBF is set to 1.
Other than the above		FCNnCMCLALBF is not changed.

FCNnCMCLCLVL	Setting FCNnCMCLVALF
0	FCNnCMCLVALF is not changed.
1	FCNnCMCLVALF is cleared to 0.

FCNnCMCLSEPS0	FCNnCMCLCLPS0	Setting FCNnCMCLMDPF0
0	1	FCNnCMCLMDPF0 is cleared to 0.
1	0	FCNnCMCLMDPF0 is set to 1.
Other than the above		FCNnCMCLMDPF0 is not changed.

FCNnCMCLSEPS1	FCNnCMCLCLPS1	Setting FCNnCMCLMDPF1
0	1	FCNnCMCLMDPF1 is cleared to 0.
1	0	FCNnCMCLMDPF1 is set to 1.
Other than the above		FCNnCMCLMDPF1 is not changed.

FCNnCMCLSEOP0	FCNnCMCLCLOP0	Setting FCNnCMCLMDOF0
0	1	FCNnCMCLMDOF0 is cleared to 0.
1	0	FCNnCMCLMDOF0 is set to 1.
Other than the above		FCNnCMCLMDOF0 is not changed.

FCNnCMCLSEOP1	FCNnCMCLCLOP1	Setting FCNnCMCLMDOF1
0	1	FCNnCMCLMDOF1 is cleared to 0.
1	0	FCNnCMCLMDOF1 is set to 1.
Other than above		FCNnCMCLMDOF1 is not changed.

FCNnCMCLSEOP2	FCNnCMCLCLOP2	Setting FCNnCMCLMDOF2
0	1	FCNnCMCLMDOF2 is cleared to 0.
1	0	FCNnCMCLMDOF2 is set to 1.
Other than above		FCNnCMCLMDOF2 is not changed.

(3) FCNnCMCLCSTR - FCNn Module Last Error Information Register

This register provides the error information of the CAN protocol.

Access This register can be read/written in 8-bit units.

Address <FCNn_base> + 0 0248_H

Initial value 00_H

This register is initialized by various types of reset

7	6	5	4	3	2	1	0
0	0	0	0	0	FCNnCMCLCSSL[2:0]		

Note 1. The contents of the FCNnCMCLCSTR register are not cleared when the FCN module changes from an operating mode to initialization mode.

Note 2. If an attempt is made to write a value other than 00_H to the FCNnCMCLCSTR register by software, the access is ignored.

FCNnCMCLCSSL[2:0]	Last FCN Protocol Error Information
000 _B	No error
001 _B	Stuff error
010 _B	Form error
011 _B	ACK error
100 _B	Bit error (The FCN module tried to transmit a recessive-level bit as part of a transmit message (except the arbitration field), but the value on the CAN bus is a dominant-level bit.)
101 _B	Bit error (The FCN module tried to transmit a dominant-level bit as part of a transmit message, ACK bit, error frame, or overload frame, but the value on the CAN bus is a recessive-level bit.)
110 _B	CRC error
111 _B	Undefined

(4) FCNnCMINSTR - FCNn Module Information Register

This register indicates the status of the FCN module.

Access This register is read-only in 8-bit units.

Address <FCNn_base> + 0 024C_H

Initial value 00_H

This register is initialized by various types of reset.

7	6	5	4	3	2	1	0
0	0	0	FCNnCM INBOFF	FCNnCM INSSTE[1:0]	FCNnCM INSSRE[1:0]		

FCNnCMINBOFF	Bus-off State
0	Not bus-off state (transmit error counter is 255 or less). (The value of the transmit counter is less than 256.)
1	Bus-off state (transmit error counter is more than 255). (The value of the transmit counter is 256 or more.)

FCNnCMINSSTE[1:0]	Transmission Error Counter Status
00 _B	The value of the transmission error counter is less than that of the warning level (less than 96).
01 _B	The value of the transmission error counter is in the range of the warning level (96 to 127).
10 _B	Setting prohibited
11 _B	The value of the transmission error counter is in the range of the error passive or bus-off status (128 or more).

FCNnCMINSSRE[1:0]	Reception Error Counter Status
00 _B	The value of the reception error counter is less than that of the warning level (less than 96).
01 _B	The value of the reception error counter is in the range of the warning level (96 to 127).
10 _B	Setting prohibited
11 _B	The value of the reception error counter is in the range of the error passive status (128 or more).

(5) FCNnCMERCNT - FCNn Module Error Counter Register

This register indicates the count value of the transmission/reception error counter.

Access This register is read-only in 16-bit units.

Address <FCNn_base> + 0 8250_H

Initial value 0000_H

This register is initialized by various types of reset.

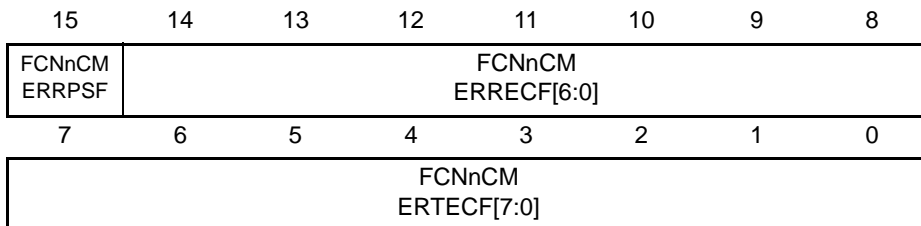

FCNnCMERRPSF	Reception Error Passive Status
0	The reception error counter is not in the error passive range (less than 128).
1	The reception error counter is in the error passive range (128 or more).

FCNnCMERRECF[6:0]	Reception Error Counter
0 to 127	Number of reception errors. These bits reflect the status of the reception error counter. The number of errors is defined by the CAN protocol.

Note FCNnCMERRECF[6:0] are invalid in the reception error passive state (FCNnCMINSTR.FCNnCMINSSRE[1:0] = 11_B).

FCNnCMERTECF[7:0]	Transmission Error Counter
0 to 255	Number of transmission errors. These bits reflect the status of the transmission error counter. The number of errors is defined by the CAN protocol.

Note FCNnCMERTECF[7:0] are invalid in the bus-off state (FCNnCMINSTR.FCNnCMINBOFF = 1).

(6) FCNnCMIECTL - FCNn Module Interrupt Enable Register

This register is used to enable or disable the interrupts of the FCN module.

Access This register can be read/written in 16-bit units.

Address <FCNn_base> + 0 8258_H

Initial value 0000_H

This register is initialized by various types of reset.

(a) FCNnCMIECTL Read

15	14	13	12	11	10	9	8
0	0	0	0	0	0	0	0

7	6	5	4	3	2	1	0
0	FCNnCMIEINTF[6:0]						

FCNnCMIEINTF[6:0]	FCN Module Interrupt Enable
0	Output of the interrupt corresponding to interrupt status register FCNnCMISCTL is disabled.
1	Output of the interrupt corresponding to interrupt status register FCNnCMISCTL is enabled.

(b) FCNnCMIECTL Write

15	14	13	12	11	10	9	8
0	FCNnCMIESEIE[6:0]						

7	6	5	4	3	2	1	0
0	FCNnCMIECLIE[6:0]						

FCNnCMIESEIE[6:0]	FCNnCMIECLIE[6:0]	Setting FCNnCMIEINTF[6:0]
0	1	FCNnCMIEINTF[6:0] bits are cleared to 0.
1	0	FCNnCMIEINTF[6:0] bits are set to 1.
Other than the above		FCNnCMIEINTF[6:0] bits are not changed.

(7) FCNnCMISCTL - FCNn Module Interrupt Status Register

This register indicates the interrupt status of the FCN module.

Access This register can be read/written in 16-bit units.

Address <FCNn_base> + 0 8260_H

Initial value 0000_H

This register is initialized by various types of reset.

(a) FCNnCMISCTL Read

15	14	13	12	11	10	9	8
0	0	0	0	0	0	0	0

7	6	5	4	3	2	1	0
0	FCNnCMISITSF[6:0]						

FCNnCMISITSF[6:0]	FCN Interrupt Status
0	No related interrupt source event is pending.
1	A related interrupt source event is pending.

Interrupt Status Bit	Related Interrupt Source Event
FCNnCMISITSF6	FCN module transmission abort interrupt status bit
FCNnCMISITSF5	Wake-up interrupt from FCN sleep mode* ¹
FCNnCMISITSF4	Arbitration loss interrupt
FCNnCMISITSF3	CAN protocol error interrupt
FCNnCMISITSF2	CAN error status interrupt
FCNnCMISITSF1	Interrupt on completion of reception of valid message frame to message buffer m
FCNnCMISITSF0	Interrupt on normal completion of transmission of message frame from message buffer m

Note 1. FCNnCMISITSF5 is set only when the FCN module is woken up from FCN sleep mode by a CAN bus operation. It is not set when FCN sleep mode has been released by software.

(b) FCNnCMISCTL Write

15	14	13	12	11	10	9	8
0	0	0	0	0	0	0	0
7	6	5	4	3	2	1	0
0	FCNnCMISCLTS[6:0]						

FCNnCMISCLTS[6:0]	Clearing FCNnCMISITSF[6:0]
0	FCNnCMISITSF[6:0] bits are not changed.
1	FCNnCMISITSF[6:0] bits are cleared to 0.

Caution Clear the status bits of this register by software, when the confirmation of each status is necessary in the interrupt processing because these bits are not cleared automatically.

(8) FCNnCMBRPRS - FCNn Module Bit-Rate Prescaler Register

This register is used to select the CAN protocol layer reference system clock (f_{TQ}). The communication baud rate is set according to the FCNnCMBTCTL register.

Access This register can be read/written in 8-bit units.

Address <FCNn_base> + 0 0268_H

Initial value FF_H

This register is initialized by various types of reset.

7	6	5	4	3	2	1	0
FCNnCMBRPRS[7:0]							

FCNnCMBRPRS [7:0]	CAN Protocol Layer Reference System Clock (f_{TQ})
0	$f_{CANMOD}/1$
1	$f_{CANMOD}/2$
n	$f_{CANMOD}/(n+1)$
:	:
255	$f_{CANMOD}/256$ (default value)

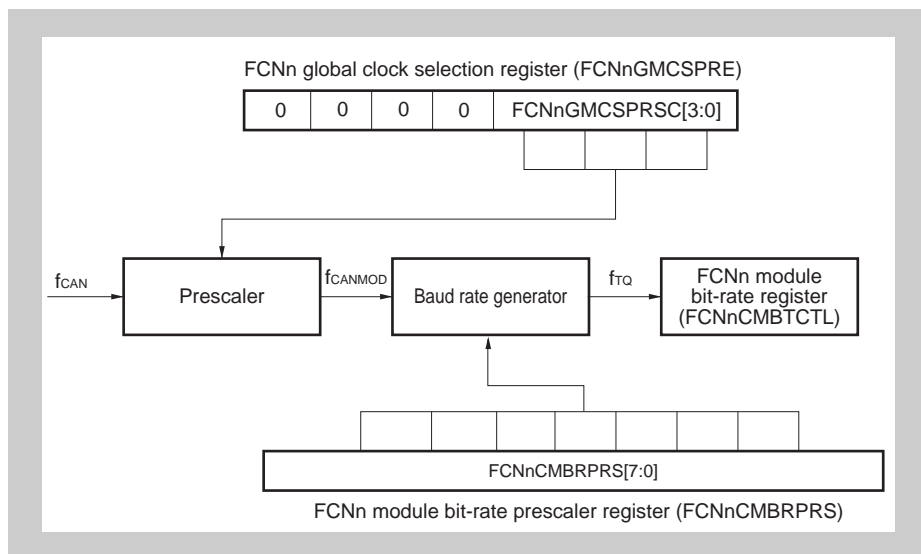

Figure 20-2 FCN Module Clock

- Note f_{CAN} : FCN reference clock
 f_{CANMOD} : FCN module system clock
 f_{TQ} : CAN protocol layer reference system clock

Caution FCNnCMBRPRS can be write-accessed only in initialization mode.

(9) FCNnCMBTCTL - FCNn Module Bit-Rate Register

This register is used to control the data bit time of the communication baud rate.

Access This register can be read/written in 16-bit units.

Address <FCNn_base> + 0 8270_H

Initial value 0370F_H

This register is initialized by various types of reset.

15	14	13	12	11	10	9	8
0	0	FCNnCM BTJWLJG[1:0]		0	FCNnCM BTS2LG[2:0]		
7	6	5	4	3	2	1	0
0	0	0	0	FCNnCMBTS1LG[3:0]			

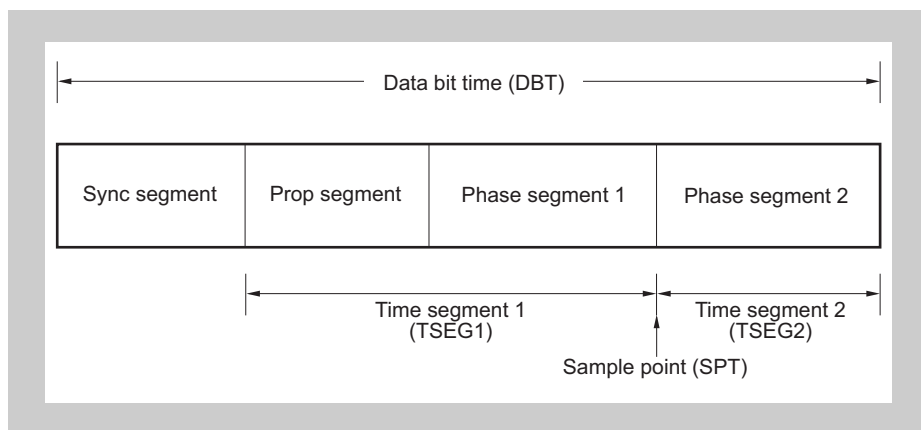

Figure 20-3 Data Bit Time

FCNnCMBTJWLJG[1:0]	Length of Synchronization Jump Width (SJW)
00 _B	1T _Q
01 _B	2T _Q
10 _B	3T _Q
11 _B	4T _Q (default value)

FCNnCMBTS2LG[2:0]	Length of Time Segment 2 (TSEG2)
000 _B	1T _Q
001 _B	2T _Q
010 _B	3T _Q
011 _B	4T _Q
100 _B	5T _Q
101 _B	6T _Q
110 _B	7T _Q
111 _B	8T _Q (default value)

FCNnCMBTS1LG[3:0]	Length of Time Segment 1 (TSEG1)
0000 _B	Setting prohibited
0001 _B	2T _Q * ¹
0010 _B	3T _Q * ¹
0011 _B	4T _Q
0100 _B	5T _Q
0101 _B	6T _Q
0110 _B	7T _Q
0111 _B	8T _Q
1000 _B	9T _Q
1001 _B	10T _Q
1010 _B	11T _Q
1011 _B	12T _Q
1100 _B	13T _Q
1101 _B	14T _Q
1110 _B	15T _Q
1111 _B	16T _Q (default value)

Note 1. This setting must not be made when the FCNnCMBRPRS register = 00_H.

Note T_Q = 1/f_{TQ} (f_{TQ}: CAN protocol layer reference system clock)

(10) FCNnCMLISTR - FCNn Module Last In-Pointer Register

This register indicates the number of the message buffer in which a data frame or a remote frame was last stored.

Access This register is read-only in 8-bit units.

Address <FCNn_base> + 0 0278_H

Initial value Undefined

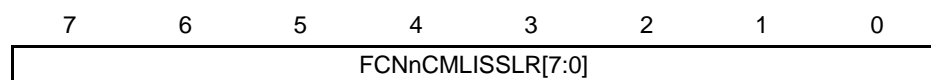

FCNnCMLISLR [7:0]	Last In-pointer Register of Receive History List
0 to 31	When the FCNnCMLISTR register is read, the contents of the element indexed by the last in-pointer (FCNnCMLISLR[7:0]) of the receive history list are read. These contents indicate the number of the message buffer in which a data frame or a remote frame was last stored.

Note The read value of FCNnCMLISTR is undefined if a data frame or a remote frame has never been stored in the message buffer. Therefore, if FCNnCMRGRX.FCNnCMRGSSPM is set to 1 after the FCN module has changed from initialization mode to an operating mode, the read value of FCNnCMLISTR is undefined.

(11) FCNnCMRGRX - FCNn Module Receive History List Register

This register is used to read the receive history list (RHL).

Access This register can be read/written in 16-bit units.

Address <FCNn_base> + 0 8280_H

Initial value xx02_H

This register is initialized by various types of reset.

(a) FCNnCMRGRX Read

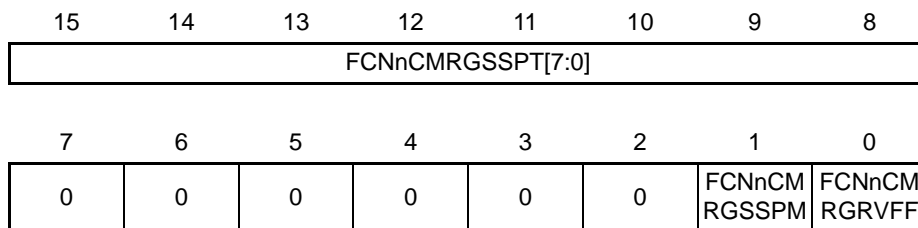

FCNnCMRGSSPT[7:0]	Receive History List Read Pointer
0 to 31	When FCNnCMRGRX is read, the contents of the element indexed by the read pointer (FCNnCMRGRX.FCNnCMRGSSPT) of the receive history list are read. These contents indicate the number of the message buffer in which a data frame or a remote frame has been stored.

FCNnCMRGSSPM*1	Receive History List Pointer
0	The receive history list has at least one message buffer number that has not been read.
1	The receive history list has no message buffer numbers that have not been read.

Note 1. The read value of FCNnCMRGSSPT[7:0] is invalid when FCNnCMRGSSPM = 1.

FCNnCMRGRVFF*1	Receive History List Overflow
0	All the message buffer numbers that have not been read are preserved. All the numbers of the message buffers in which a new data frame or remote frame has been received and stored are recorded to the receive history list (the receive history list has a vacant element).
1	At least 23 entries have been stored since the host processor has serviced the RHL last time (i.e. read FCNnCMRGRX). The first 22 entries are sequentially stored while the last entry can have been overwritten whenever newly received message is stored, because all message buffer numbers are stored at position 23, when FCNnCMRGRVFF is set. Thus, the sequence of receptions cannot be recovered completely now.

Note 1. If FCNnCMRGRVFF is set, FCNnCMRGSSPM is no longer cleared on message storage, but FCNnCMRGSSPM is still set if all entries of FCNnCMRGRX have been read by software.

(b) FCNnCMRGRX Write

15	14	13	12	11	10	9	8
0	0	0	0	0	0	0	0
7	6	5	4	3	2	1	0
0	0	0	0	0	0	0	FCNnCMRGCLR

FCNnCMRGCLR	Clearing FCNnCMRGRVFF
0	FCNnCMRGRVFF bit is not changed.
1	FCNnCMRGRVFF bit is cleared to 0.

(12) FCNnCMLOSTR - FCNn Module Last Out-Pointer Register

This register indicates the number of the message buffer, from which a data frame or a remote frame was transmitted last.

Access This register is read-only in 8-bit units.

Address <FCNn_base> + 0 0288_H

Initial value Undefined

7	6	5	4	3	2	1	0
FCNnCMLOSSLT[7:0]							

FCNnCMLOSSLT [7:0]	Last Out-pointer of Transmit History List
0 to 31	When FCNnCMLOSSLT is read, the contents of the element indexed by the last out-pointer (FCNnCMLOSTR[7:0]) of the transmit history list are read. These contents indicate the number of the message buffer to which a data frame or a remote frame was transmitted last.

Caution The value read from the FCNnCMLOSTR register is undefined if a data frame or remote frame has never been transmitted from the message buffer. Therefore when FCNnCMTGTX.FCNnCMTGSSPM is set at transition from initial mode to operation mode, read value of FCNnCMLOSTR is undefined.

(13) FCNnCMTGTX - FCNn Module Transmit History List Register

This register is used to read the transmit history list (THL).

Access This register can be read/written in 16-bit units.

Address <FCNn_base> + 0 8290_H

Initial value xx02_H

This register is initialized by various types of reset.

(a) FCNnCMTGTX Read

15	14	13	12	11	10	9	8
FCNnCMTGSSPT[7:0]							
7	6	5	4	3	2	1	0
0	0	0	0	0	0	FCNnCM TGSSPM	FCNnCM TGTVFF

FCNnCMTGSSPT[7:0]	Transmit History List Read Pointer
0 to 31	When FCNnCMTGTX is read, the contents of the element indexed by the read pointer (FCNnCMTGSSPT[7:0]) of the transmit history list are read. These contents indicate the number of the message buffer to which a data frame or a remote frame was transmitted last.

FCNnCMTGSSPM* ¹	Transmit History Pointer
0	The transmit history list has at least one message buffer number that has not been read.
1	The transmit history list has no message buffer numbers that have not been read.

Note 1. The read value of FCNnCMTGSSPT[7:0] is invalid when FCNnCMTGSSPM = 1.

FCNnCMTGTVFF * ¹	Transmit History List Overflow
0	All the message buffer numbers that have not been read are preserved. All the numbers of the message buffers to which a new data frame or remote frame has been transmitted are recorded to the transmit history list (the transmit history list has a vacant element).
1	At least 7 entries have been stored since the host processor has serviced the THL last time (e.g, read FCNnCMTGTX). The first 6 entries are sequentially stored while the last entry is overwritten whenever a new message is completed, because all message buffer numbers are stored at position 7, when FCNnCMTGTVFF is set. Thus, the sequence of transmission cannot be recovered completely.

Note 1. If FCNnCMTGTVFF is set, FCNnCMTGSSPM is no longer cleared on message transmission, but FCNnCMTGSSPM is still set, if all entries of FCNnCMTGTX are read by software.

Note Transmission from the following message buffers is not recorded to the transmit history list in normal operating mode with ABT.

- 0 to 16

(b) FCNnCMTGTX Write

15	14	13	12	11	10	9	8
0	0	0	0	0	0	0	0
7	6	5	4	3	2	1	0
0	0	0	0	0	0	0	FCNnCM TGCLTV

FCNnCMTGCLTV	Setting FCNnCMTGTVFF
0	FCNnCMTGTVFF bit is not changed.
1	FCNnCMTGTVFF bit is cleared to 0.

(14) FCNnCMTSCTL - FCNn Module Time Stamp Register

This register is used to control the time stamp function.

Access This register can be read/written in 16-bit units.

Address <FCNn_base> + 0 8298_H

Initial value 0000_H

This register is initialized by various types of reset.

(a) FCNnCMTSCTL Read

15	14	13	12	11	10	9	8
0	0	0	0	0	0	0	0
7	6	5	4	3	2	1	0
0	0	0	0	0	FCNnCM TSLOKE	FCNnCM TSSELE	FCNnCM TSTSGE

Note The lock function of the time stamp function must not be used when the FCN module is in normal operating mode with ABT.

FCNnCMTSLOKE	Time Stamp Lock Function Enable
0	Time stamp lock function stopped. The TSOUT signal is toggled each time the selected time stamp capture event occurs.
1	Time stamp lock function enabled. The TSOUT signal is toggled each time the selected time stamp capture event occurs. However, the TSOUT output signal is locked when a data frame has been correctly received to message buffer 0. *1

Note 1. FCNnCMTTSGE is automatically cleared to 0.

FCNnCMTSSELE	Time Stamp Capture Event Selection
0	The time capture event is SOF.
1	The time stamp capture event is the last bit of EOF.

FCNnCMTSTSGE	Setting TSOUT Operation
0	TSOUT toggle operation is disabled.
1	TSOUT toggle operation is enabled.

(b) FCNnCMTSCTL Write

15	14	13	12	11	10	9	8
0	0	0	0	0	FCNnCM TSSELK	FCNnCM TSSESL	FCNnCM TSSETS

7	6	5	4	3	2	1	0
0	0	0	0	0	FCNnCM TSCLKK	FCNnCM TSCLSL	FCNnCM TSCLTS

FCNnCMTSSELK	FCNnCMTSCLKK	Setting FCNnCMTSLOKE
0	1	FCNnCMTSLOKE is cleared to 0.
1	0	FCNnCMTSLOKE is set to 1.
Other than the above		FCNnCMTSLOKE is not changed.

FCNnCMTSSESL	FCNnCMTSCLSL	Setting FCNnCMTSSELE
0	1	FCNnCMTSSELE is cleared to 0.
1	0	FCNnCMTSSELE is set to 1.
Other than the above		FCNnCMTSSELE is not changed.

FCNnCMTSSETS	FCNnCMTSCLTS	Setting FCNnCMTSTSGE
0	1	FCNnCMTSTSGE is cleared to 0.
1	0	FCNnCMTSTSGE is set to 1.
Other than the above		FCNnCMTSTSGE is not changed.

20.5.3 FCN Message Buffer Registers

(1) FCNnMmDATxB/H/W - FCNn Message Data Byte Registers

These registers are used to store the data of transmit/receive messages.

Access The FCNnMmDATxW registers can be read/written in 32-bit units.
The FCNnMmDATxH registers can be read/written in 16-bit units.
The FCNnMmDATxB registers can be read/written in 8-bit units.

Address FCNnMmDAT0B: $\langle \text{FCNn_base} \rangle + 0\ 1000_{\text{H}} + m \times 40_{\text{H}}$
FCNnMmDAT1B: $\langle \text{FCNn_base} \rangle + 0\ 1004_{\text{H}} + m \times 40_{\text{H}}$
FCNnMmDAT2B: $\langle \text{FCNn_base} \rangle + 0\ 1008_{\text{H}} + m \times 40_{\text{H}}$
FCNnMmDAT3B: $\langle \text{FCNn_base} \rangle + 0\ 100\text{C}_{\text{H}} + m \times 40_{\text{H}}$
FCNnMmDAT4B: $\langle \text{FCNn_base} \rangle + 0\ 1010_{\text{H}} + m \times 40_{\text{H}}$
FCNnMmDAT5B: $\langle \text{FCNn_base} \rangle + 0\ 1014_{\text{H}} + m \times 40_{\text{H}}$
FCNnMmDAT6B: $\langle \text{FCNn_base} \rangle + 0\ 1018_{\text{H}} + m \times 40_{\text{H}}$
FCNnMmDAT7B: $\langle \text{FCNn_base} \rangle + 0\ 101\text{C}_{\text{H}} + m \times 40_{\text{H}}$

FCNnMmDAT0H: $\langle \text{FCNn_base} \rangle + 0\ 9000_{\text{H}} + m \times 40_{\text{H}}$
FCNnMmDAT2H: $\langle \text{FCNn_base} \rangle + 0\ 9008_{\text{H}} + m \times 40_{\text{H}}$
FCNnMmDAT4H: $\langle \text{FCNn_base} \rangle + 0\ 9010_{\text{H}} + m \times 40_{\text{H}}$
FCNnMmDAT6H: $\langle \text{FCNn_base} \rangle + 0\ 9018_{\text{H}} + m \times 40_{\text{H}}$

FCNnMmDAT0W: $\langle \text{FCNn_base} \rangle + 1\ 1000_{\text{H}} + m \times 40_{\text{H}}$
FCNnMmDAT4W: $\langle \text{FCNn_base} \rangle + 1\ 1010_{\text{H}} + m \times 40_{\text{H}}$

Initial value FCNnMmDATxB 00_H
FCNnMmDATyH 0000_H
FCNnMmDATzW 0000 0000_H

This register can be initialized by various reset operations.

(a) FCNnMmDATxB (x = 0 to 7)

7	6	5	4	3	2	1	0
FCNnMmSSDx0, FCNnMmSSDx1, FCNnMmSSDx2, FCNnMmSSDx3, FCNnMmSSDx4, FCNnMmSSDx5, FCNnMmSSDx6, FCNnMmSSDx7							

(b) FCNnMmDATyH (y = 0, 2, 4, 6)

15	14	13	12	11	10	9	8
FCNnMmSSD(y+1)0, FCNnMmSSD(y+1)1, FCNnMmSSD(y+1)2, FCNnMmSSD(y+1)3, FCNnMmSSD(y+1)4, FCNnMmSSD(y+1)5, FCNnMmSSD(y+1)6, FCNnMmSSD(y+1)7							

7	6	5	4	3	2	1	0
FCNnMmSSDy0, FCNnMmSSDy1, FCNnMmSSDy2, FCNnMmSSDy3, FCNnMmSSDy4, FCNnMmSSDy5, FCNnMmSSDy6, FCNnMmSSDy7							

(c) FCNnMmDATzW (z = 0, 4)

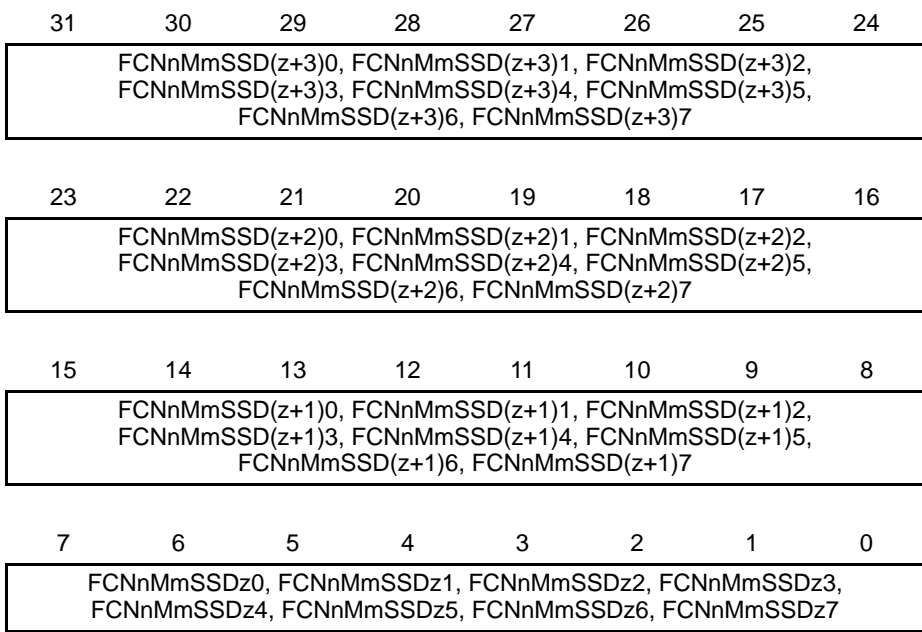

(2) FCNnMmDTLGB - FCNn Message Data Length Register m

This register is used to set the number of bytes of the data field of a message buffer.

Access This register can be read/written in 8-bit units.

Address <FCNn_base> + 0 1020_H + m × 40_H

Initial value 00_H

This register can be initialized by various reset operations.

7	6	5	4	3	2	1	0
0	0	0	0	FCNnMmDTLG[3:0]			

FCNnMmDTLG[3:0]	Data Length of Transmit/Receive Message
0000 _B	0 bytes
0001 _B	1 byte
0010 _B	2 bytes
0011 _B	3 bytes
0100 _B	4 bytes
0101 _B	5 bytes
0110 _B	6 bytes
0111 _B	7 bytes
1000 _B	8 bytes
1001 _B	Setting prohibited (If these bits are set during transmission, 8-byte data is transmitted regardless of the set FCNnMmDTLG[3:0] value when a data frame is transmitted. However, the DLC actually transmitted to the CAN bus is the DLC value set to this register.) *
1010 _B	
1011 _B	
1100 _B	
1101 _B	
1110 _B	
1111 _B	

Note: * The data and DLC value actually transmitted to CAN bus are as follows.

Type of Transmit Frame	Length of Transmit Data	DLC Transmitted
Data frame	Number of bytes specified by FCNnMmDTLG[3:0] (However, 8 bytes if the set value is 8 or more)	Set value of FCNnMmDTLGB.FC NnMmDTLG[3:0] bits
Remote frame	0 bytes	

- Caution 1. Be sure to set bits 7 to 4 to 0000_B.
- Caution 2. Receive data is stored in as many FCNnMmDATxB register as the number of bytes (however, the upper limit is 8) corresponding to DLC of the received frame. The FCNnMmDATxB register in which no data is stored is undefined.
- Caution 3. On reception, FCNnMmDTLGB is updated according to the received frame.

(3) FCNnMmSTRB - FCNn Message Configuration Register m

This register is used to specify the type of the message buffer and to set a mask.

Access This register can be read/written in 8-bit units.

Address <FCNn_base> + 0 1024_H + m × 40_H

Initial value 00_H

This register can be initialized by various reset operations.

7	6	5	4	3	2	1	0
FCNnMmSSOW	FCNnMmSSMT[3:0]			FCNnMmSSRT	0	FCNnMmSSAM	

FCNnMmSSOW	Overwrite Control
0	The message buffer that has already received a data frame* ¹ is not overwritten by a newly received data frame. The newly received data frame is discarded.
1	The message buffer that has already received a data frame* ¹ is overwritten by a newly received data frame.

Note 1. The “message buffer that has already received a data frame” is a receive message buffer whose FCNnMmCTL.FCNnMmDTNF bit has been set to 1.

Note Reception and storage of remote frames in the transmit message buffer do not depend on the settings of FCNnMmCTL.FCNnMmSSOW and FCNnMmCTL.FCNnMmDTNF. A remote frame that meets other conditions (matching of ID, FCNnMmSTRB.FCNnMmSSRT = 0, and FCNnMmCTL.FCNnMmTRQF = 0) is always received and stored in the corresponding message buffer (with interrupt generation, FCNnMmDTNF flag setting, FCNnMmDTLBG.FCNnMmDTLG[3:0] bits update, and receive history list recording).

FCNnMmSSRT	Remote Frame Request
0	Transmit or receive a data frame.
1	Transmit or receive a remote frame.

FCNnMmSTRB.FCNnMmSSRT specifies the type of message frame that is transmitted or received from/to a message buffer.

- Note 1. If the message buffer is defined as a transmit message buffer, and a remote frame shall be received into it, the FCNnMmSSRT bit must be cleared.
- Note 2. Even if a valid remote frame has been received in a transmit message buffer, the FCNnMmSSRT bit of the transmit message buffer that has received the frame remains cleared to 0.
- Note 3. Even if a remote frame whose ID matches has been received from the CAN bus, if the FCNnMmSSRT bit of a transmit message buffer is set to 1 (to transmit a remote frame), that remote frame is not stored in this transmit message buffer.
- Note 4. If the message buffer is defined as a receive message buffer, the FCNnMmSSRT bit must be set, in order to receive remote frames instead of data frames.

FCNnMmSSMT[3:0]	Message Buffer Type Setting
0000 _B	Transmit message buffer
0001 _B	Receive message buffer (no mask setting)
0010 _B	Receive message buffer (mask 1 set)
0011 _B	Receive message buffer (mask 2 set)
0100 _B	Receive message buffer (mask 3 set)
0101 _B	Receive message buffer (mask 4 set)
0110 _B	Receive message buffer (mask 5 set)
0111 _B	Receive message buffer (mask 6 set)
1000 _B	Receive message buffer (mask 7 set)
1001 _B	Receive message buffer (mask 8 set)
Other than the above	Setting prohibited

Note The setting of FCNnMmSSMT is also valid to select masks in conjunction with remote frame reception. To receive remote frames in receive message buffers, the FCNnMmSSRT flag of the message buffer must be set.

FCNnMmSSAM	Message Buffer Assignment
0	Message buffer not used.
1	Message buffer used.

Caution Be sure to write 0 to bit 1.

(4) FCNnMmMID0H, FCNnMmMID1H, FCNnMmMID0W - FCNn Message ID Register m

These registers are used to set an identifier (ID).

Access FCNnMmMID0H and FCNnMmMID1H can be read/written in 16-bit units.
FCNnMmMID0W can be read/written in 32-bit units.

Address FCNnMmMID0H: <FCNn_base> + 0 9028_H + m × 40_H
FCNnMmMID1H: <FCNn_base> + 0 9030_H + m × 40_H
FCNnMmMID0W: <FCNn_base> + 1 1028_H + m × 40_H

Initial value FCNnMmMID0H 0000_H
FCNnMmMID1H 0000_H
FCNnMmMID0W 0000 0000_H
This register can be initialized by various reset operations.

(a) FCNnMmMID0H

15	14	13	12	11	10	9	8
FCNnMmSSID[15:8]							
7	6	5	4	3	2	1	0
FCNnMmSSID[7:0]							

(b) FCNnMmMID1H

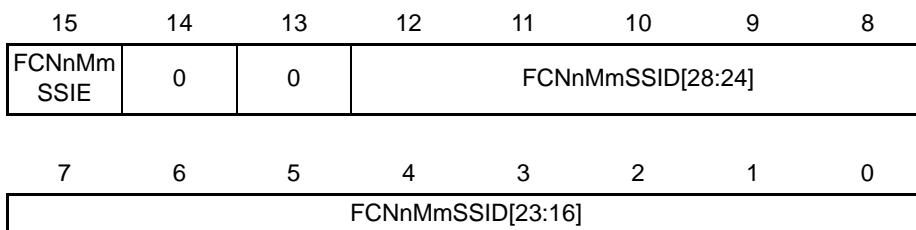

(c) FCNnMmMID0W

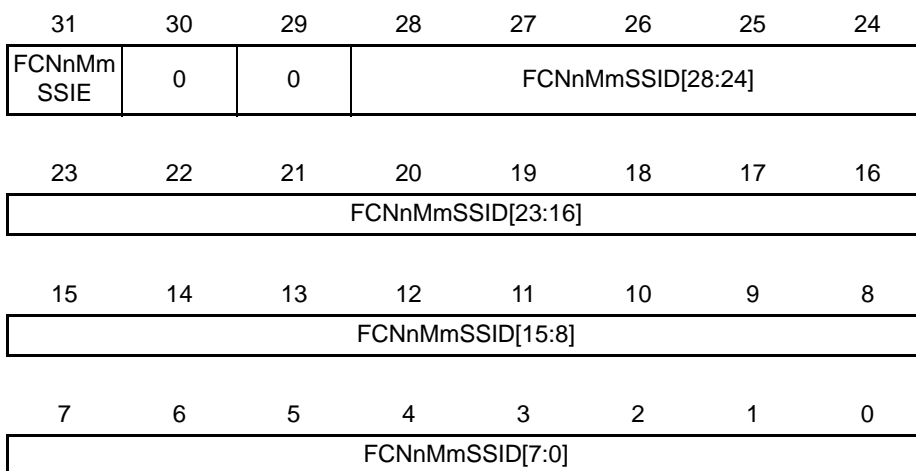

FCNnMmSSIE	Format Mode Specification
0	Standard format mode (FCNnMmSSID[28:18]: 11 bits, FCNnMmSSID[17:0] are not used)
1	Extended format mode (FCNnMmSSID[28:0]: 29 bits)

FCNnMmSSID[28:0]	Message ID
FCNnMmSSID[28:18]	Standard ID value of 11 bits (when FCNnMmSSIE = 0)
FCNnMmSSID[28:0]	Extended ID value of 29 bits (when FCNnMmSSIE = 1)

- Caution 1. Be sure to write 0 to bits 14 and 13 of FCNnMmMID1H, and bits 30 and 29 of FCNnMmMID0W register.
- Caution 2. Be sure to align the ID value with the specified bit position in this register. Note that for standard ID, the ID value must be shifted to fit into FCNnMmSSID[28:18] bit positions.

(5) FCNnMmCTL - FCNn Message Control Register m

This register is used to control the operation of the message buffer.

Access This register can be read/written in 16-bit units.

Address <FCNn_base> + 0 9038_H + m × 40_H

Initial value 0000_H

This register can be initialized by various reset operations.

(a) FCNnMmCTL Read

15	14	13	12	11	10	9	8
0	0	FCNnMm MUCF	0	0	0	FCNnMm TCPF	0
7	6	5	4	3	2	1	0
0	FCNnMm NHMF	0	FCNnMm MOWF	FCNnMm IENF	FCNnMm DTNF	FCNnMm TRQF	FCNnMm RDYF

FCNnMmMUCF	Message Buffer Data Being Updated
0	The FCN module is not updating (receiving and storing) the message buffer.
1	The FCN module is updating (receiving and storing) the message buffer.

FCNnMmTCPF* ¹	Transmission Completion Flag
0	Transmission failed.* ²
1	Transmission completed.

Note 1. FCNnMmTCPF is cleared if FCNnMmRDYF is changed or FCNnMmTRQF is set.

Note 2. This indicates a successful transmission abort, if this was requested by the application by clearing the FCNnMmTRQF flag.

FCNnMmNHMF	History Mask Flag * ¹
0	Update of receive/transmit history list registers FCNnCMRGRX/FCNnCMRGTX is not masked.
1	Update of receive/transmit history list registers FCNnCMRGRX/FCNnCMRGTX is masked.

Note 1. When masked, the history lists are not updated upon reception or transmission completion activity on this message buffer.

FCNnMmMOWF	Message Buffer Overwrite Status
0	The message buffer is not overwritten by a newly received data or remote frame.
1	The message buffer is overwritten by a newly received data or remote frame.

Note This bit is not set to 1 even if a remote frame is received and stored in the transmit message buffer of FCNnMmDTNF = 1.

FCNnMmIENF	Message Buffer Interrupt Request Enable
0	Receive message buffer: Valid message reception completion interrupt disabled. Transmit message buffer: Normal message transmission completion interrupt and abort interrupt disabled.
1	Receive message buffer: Valid message reception completion interrupt enabled. Transmit message buffer: Normal message transmission completion interrupt and abort interrupt enabled.

Caution Be sure to set FCNnMmIENF and FCNnMmRDYF separately.

FCNnMmDTNF	Message Buffer Data Update
0	No new data frame or remote frame has been stored in the message buffer.
1	A new data frame or remote frame has been stored in the message buffer.

Caution Do not set FCNnMmDTNF to 1 by software. Be sure to write 0 to bit 10.

FCNnMmTRQF	Message Buffer Transmission Request
0	No message frame transmitting request that is pending or being transmitted is in the message buffer.
1	The message buffer is holding transmission of a message frame pending or is transmitting a message frame.

Caution 1. Do not set FCNnMmTRQF and FCNnMmRDYF at the same time. Set FCNnMmRDYF = 1 and then set FCNnMmTRQF = 1.

Caution 2. Do not set FCNnMmTRQF to 1 for other than the transmit message buffer (buffer of FCNnMmSSMT[3:0] are not 4'b0000 or FCNnMmSSAM = 0).

FCNnMmRDYF	Message Buffer Ready
0	The message buffer can be written by software. The FCN module cannot write to the message buffer.
1	Writing the message buffer by software is ignored (except a write access to FCNnMmRDYF, FCNnMmTRQF, FCNnMmDTNF, and FCNnMmMOWF). The FCN module can write to the message buffer.

Caution 1. Be sure to set FCNnMmIENF and FCNnMmRDYF separately.

Caution 2. Do not set FCNnMmTRQF and FCNnMmRDYF to 1 at the same time. Set FCNnMmRDYF = 1 and then set FCNnMmTRQF = 1.

Caution 3. Do not clear FCNnMmRDYF to 0 during message transmission. To redefine the message buffer, perform the transmission abort processing to clear FCNnMmRDYF.

- Caution 4. Clearing of FCNnMmRDYF may take some time, depending on activity of the CAN controller. Repeat the clearing access until reading of FCNnMmRDYF confirms that the bit has been cleared.
- Caution 5. Make sure that FCNnMmRDYF is cleared before writing to another FCN message buffer registers by checking the status of FCNnMmRDYF.

(b) FCNnMmCTL Write

15	14	13	12	11	10	9	8
0	FCNnMm SENH	0	0	FCNnMm SEIE	0	FCNnMm SETR	FCNnMm SERY
7	6	5	4	3	2	1	0
0	FCNnMm CLNH	0	FCNnMm CLMW	FCNnMm CLIE	FCNnMm CLDN	FCNnMm CLTR	FCNnMm CLRY

FCNnMmSENH	FCNnMmCLNH	Setting FCNnMmNHMF
0	1	FCNnMmNHMF is cleared to 0.
1	0	FCNnMmNHMF is set to 1.
Other than above		FCNnMmNHMF is not changed.

FCNnMmCLMW	Setting FCNnMmMOWF
0	FCNnMmMOWF is not changed.
1	FCNnMmMOWF is cleared to 0.

FCNnMmSEIE	FCNnMmCLIE	Setting FCNnMmIENF
0	1	FCNnMmIENF is cleared to 0.
1	0	FCNnMmIENF is set to 1.
Other than the above		FCNnMmIENF is not changed.

Caution Be sure to set FCNnMmIENF and FCNnMmRDYF separately.

FCNnMmCLDN	Setting FCNnMmDTNF
0	FCNnMmDTNF is not changed.
1	FCNnMmDTNF is cleared to 0.

Note If FCNnMmDTNF is cleared by the completion of ID field receiving, the message buffer participates in the search to store the receiving frame.

Caution Do not set FCNnMmDTNF to 1 by software. Be sure to write 0 to bit 10.

FCNnMmSETR	FCNnMmCLTR	Setting FCNnMmTRQF
0	1	FCNnMmTRQF is cleared to 0.
1	0	FCNnMmTRQF is set to 1.
Other than the above		FCNnMmTRQF is not changed.

Caution Do not set FCNnMmTRQF and FCNnMmRDYF at the same time. Set FCNnMmRDYF = 1, and then set FCNnMmTRQF = 1.

FCNnMmSERY	FCNnMmCLRY	Setting FCNnMmRDYF
0	1	FCNnMmRDYF is cleared to 0.
1	0	FCNnMmRDYF is set to 1.
Other than the above		FCNnMmRDYF is not changed.

-
- Caution 1. Be sure to set FCNnMmIENF and FCNnMmRDYF separately.
- Caution 2. Do not set FCNnMmTRQF and FCNnMmRDYF to 1 at the same time. Set FCNnMmRDYF = 1, and then set FCNnMmTRQF = 1.
- Caution 3. Do not clear FCNnMmRDYF to 0 during message transmission. To redefine the message buffer, perform the transmission abort processing to clear FCNnMmRDYF.
- Caution 4. Clearing of FCNnMmRDYF may take some time, depending on activity of the CAN controller. Repeat the clearing access until reading of FCNnMmRDYF confirms that the bit has been cleared.
- Caution 5. Make sure that FCNnMmRDYF is cleared before writing to another message buffer register by checking the status of FCNnMmRDYF.
-

20.6 CAN Controller Initialization

20.6.1 Initialization of FCN Module

To enable FCN module operation, the FCN module system clock needs to be determined by setting FCNnGMCSPRE.FCNnGMCSPRSC[3:0] by software. Do not change the setting of the FCN module system clock after FCN module operation is enabled.

The FCN module is enabled by setting FCNnGMCLCTL.FCNnGMCLPWOM.

For the procedure of initializing the FCN module, see Section 20.14, Operation of the CAN Controller.

20.6.2 Redefinition of Message Buffer

Redefining a message buffer is to change the ID and control information of the message buffer while a message is being received or transmitted, without affecting other transmission/reception operations.

(1) Redefining Message Buffer in Initialization Mode

Place the FCN module in initialization mode once and then change the ID and control information of the message buffer in initialization mode. After the ID and control information are changed, set the FCN module to an operating mode.

(2) Redefining Message Buffer during Reception

Perform redefinition as shown in Figure 20-17, Message Buffer Redefinition during Reception.

(3) Redefining Message Buffer during Transmission

To rewrite the contents of a transmit message buffer to which a transmission request has been set, perform transmission abort processing (see the description in Section 20.8.4, (1) Transmission Abort Process except for in Normal Operating Mode with Automatic Block Transmission (ABT) and ((2) Transmission Abort Process in Normal Operating Mode with Automatic Block Transmission (ABT)). Confirm that transmission has been aborted or completed, and then redefine the message buffer. After the transmit message buffer is redefined, set a transmission request using the procedure described below.

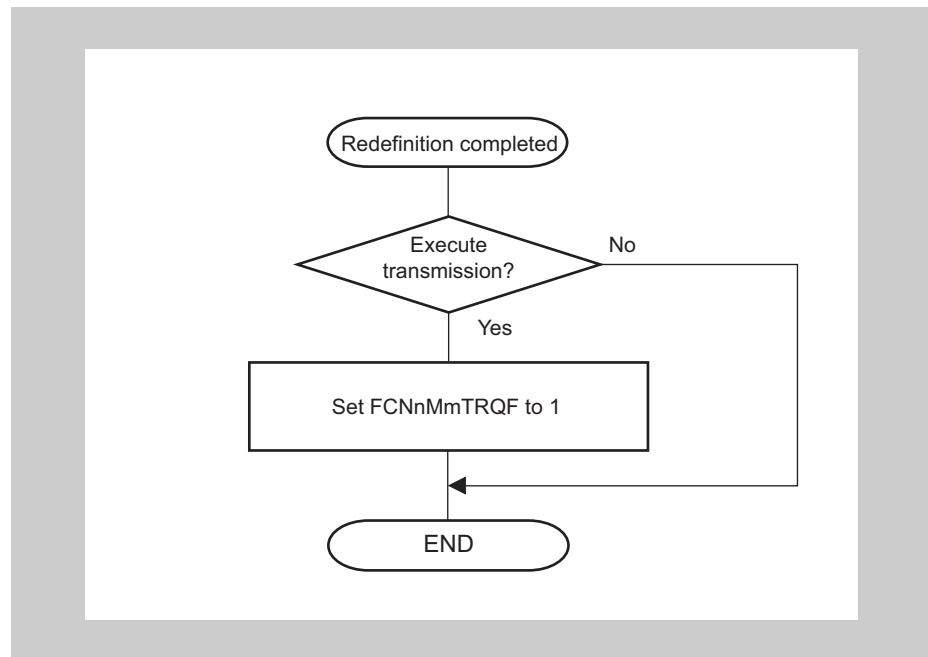

Figure 20-4 Setting Transmission Request (FCNnMmCTL.FCNnMmTRQF) to Transmit Message Buffer after Redefinition

- Caution 1. When a message is received, reception filtering is performed in accordance with the ID and mask set to each receive message buffer. If the procedure in Figure 20-17, Message Buffer Redefinition during Reception, is not observed, the contents of the message buffer after it has been redefined may contradict the result of reception (result of reception filtering). If this happens, check that the ID and IDE received first and stored in the message buffer following redefinition are those stored after the message buffer has been redefined. If no ID and IDE are stored after redefinition, redefine the message buffer again.
- Caution 2. When a message is transmitted, the transmission priority is checked in accordance with the ID, IDE, and FCNnMmSTRB.FCNnMmSSRT set to each transmit message buffer to which a transmission request was set. The transmit message buffer having the highest priority is selected for transmission. If the procedure in Figure 20-4, Setting Transmission Request (FCNnMmCTL.FCNnMmTRQF) to Transmit Message Buffer after Redefinition to Transmit Message Buffer after Redefinition, is not observed, a message with an ID having the highest priority may not be transmitted after redefinition.

20.6.3 Transition from Initialization Mode to Operating Mode

The FCN module can be switched to the following operating modes.

- Normal operating mode
- Normal operating mode with ABT
- Receive-only mode
- Single-shot mode
- Self-test mode

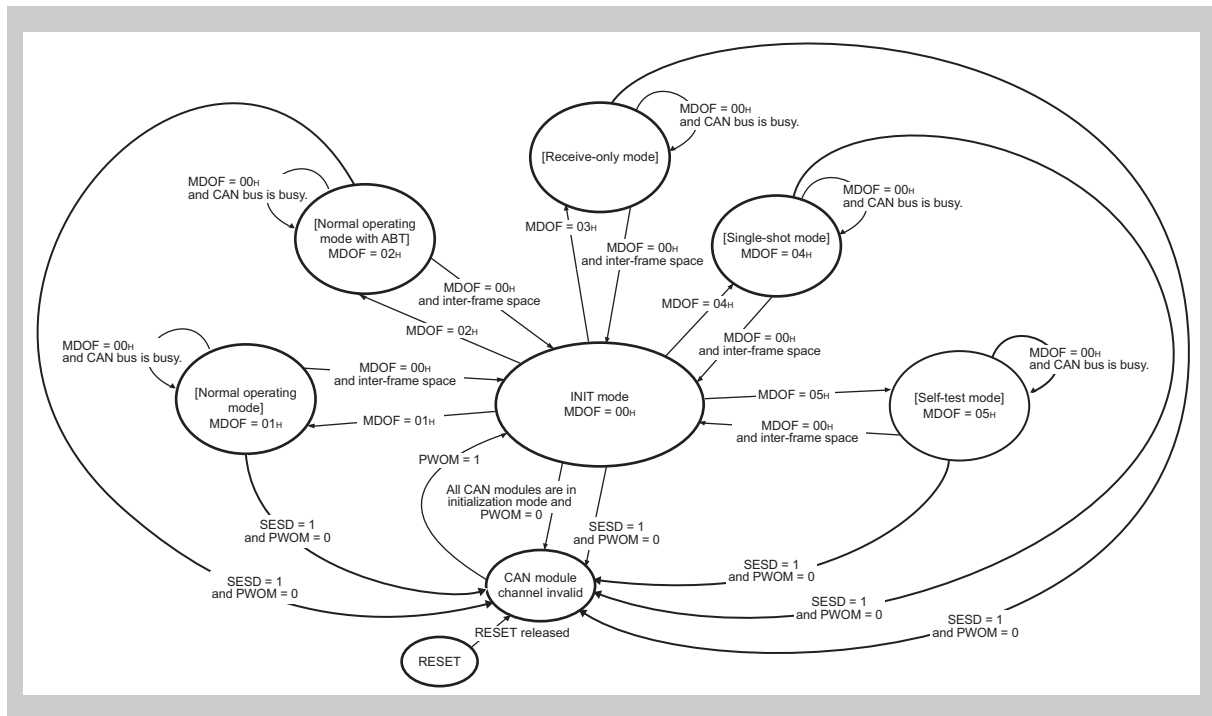

Figure 20-5 Transition to Operating Modes

Note The following abbreviations are used in the figure above.

- MDOF = FCNnCMCLCTL.FCNnCMCLMDOF[2:0]
- PWOM = FCNnGMCLCTL.FCNnGMCLPWOM
- SESD = FCNnGMCLCTL.FCNnGMCLSESD

The transition from initialization mode to an operating mode is controlled by FCNnCM.FCNnCMCLMDOF[2:0].

Changing from one operating mode to another requires shifting to initialization mode in between. Do not change one operating mode to another directly. Otherwise, the operation will not be guaranteed.

Requests for transition from an operating mode to initialization mode are held pending when the CAN bus is not in the inter-frame space (i.e., frame reception or transmission is in progress), and the FCN module enters initialization mode at the first bit in the inter-frame space (the values of FCNnCMCLCTL.FCNnCMCLMDOF[2:0] are changed to 000_B). After issuing a request to change the mode to initialization mode, read FCNnCMCLCTL.FCNnCMCLMDOF[2:0] until their values become 000_B to confirm that the module has entered initialization mode (see Figure 20-14, Re-initialization without Software Reset Function).

20.7 Reception of Message

20.7.1 Message Reception

In all operating modes, the entire message buffer area is analyzed to find a suitable buffer to store a newly received message. All message buffers satisfying the following conditions are included in that evaluation (RX-search process).

- Used as a message buffer
(FCNnMmSTRB.FCNnMmSSAM = 1)
- Set as a receive message buffer
(FCNnMmSTRB.FCNnMmSSMT[3:0] = 0001_B to 1001_B)
- Ready for reception
(FCNnMmCTL.FCNnMmRDYF = 1)

When two or more message buffers of the FCN module are able to receive a message, the message is stored according to the priority described below. The message is always stored in the message buffer with the highest priority, not in a message buffer with a low priority. For example, when an unmasked receive message buffer and a receive message buffer linked to mask 1 have the same ID, the received message is not stored in the message buffer linked to mask 1, even if that message buffer has not received a message and a message has already been received in the unmasked receive message buffer. In other words, when a condition has been set in two or more message buffers with different priorities, the message buffer with the highest priority always stores the message; the message is not stored in message buffers with a lower priority. This also applies when the message buffer with the highest priority is unable to store a message (i.e., when FCNnMmCTL.FCNnMmDTNF = 1 indicating that a message has already been received, but rewriting is disabled because FCNnMmSTRB.FCNnMmSSOW = 0). In this case, the message is not actually stored in the candidate message buffer with the highest priority, but neither is it stored in a message buffer with a lower priority.

Table 20-16 MBRB Priorities

Priority	Storing Condition if Same ID is Set	
1 (high)	Unmasked message buffer	FCNnMmDTNF = 0
		FCNnMmDTNF = 1 and FCNnMmSSOW = 1
2	Message buffer linked to mask 1	FCNnMmDTNF = 0
		FCNnMmDTNF = 1 and FCNnMmSSOW = 1
3	Message buffer linked to mask 2	FCNnMmDTNF = 0
		FCNnMmDTNF = 1 and FCNnMmSSOW = 1
...
9 (low)	Message buffer linked to mask 8	FCNnMmDTNF = 0
		FCNnMmDTNF = 1 and FCNnMmSSOW = 1

20.7.2 Receive Data Read

To keep data consistency when reading message buffers, read data according to the procedures in Figure 20-31, Reception via Interrupt (Using FCNnCMISTR Register), to Figure 20-34, Reception via Software Polling.

During message reception, the FCN module sets FCNnMmCTL.FCNnMmDTNF two times: at the beginning of the storage process of data to the message buffer, and again at the end of this storage process. During this storage process, FCNnMmCTL.FCNnMmMUCF of the message buffer is set (see Figure 20-6, Reception Timing).

The receive history list is also updated just before the storage process. In addition, during storage process (FCNnMmCTL.FCNnMmMUCF = 1), FCNnMmCTL.FCNnMmRDYF of the message buffer is locked to avoid any coincidental data write by the CPU. Note that the storage process may be disturbed (delayed) when the CPU accesses the message buffer.

Caution To securely store a message in the message buffer, the FCNnMmCTL.FCNnMmDTNF bit of the buffer must be cleared before the message search processing is started (before the frame ID is output to the bus). This is the 15th of CAN bits after EOF of the previous frame at shortest. To securely receive CAN frames that continuously appear on the bus, it is recommended that one more message buffers for frame reception be used.

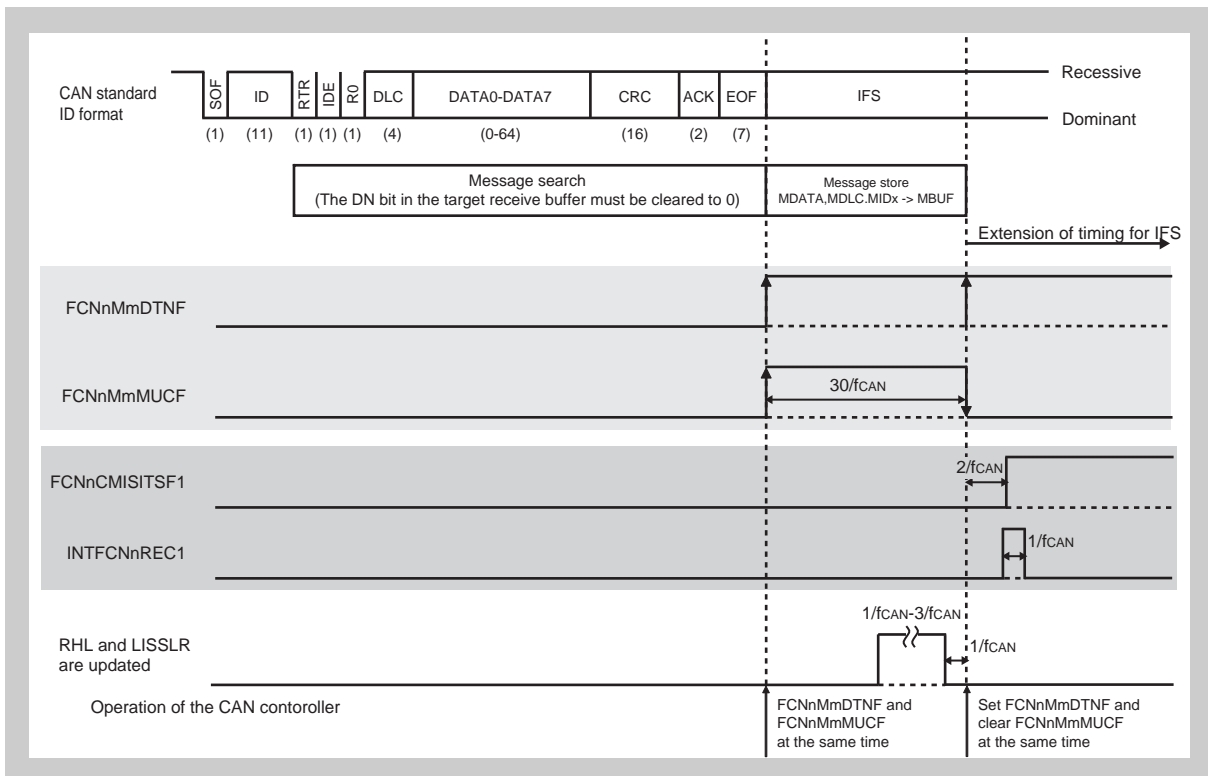

Figure 20-6 Reception Timing

20.7.3 Receive History List Function

The receive history list (RHL) function records in the receive history list the number of the receive message buffer in which each data frame or remote frame was received and stored. The RHL consists of storage elements equivalent to up to 23 messages, the last in-message pointer FCNnCMLISSLR[7:0] with the corresponding FCNnCMLISTR register and the receive history list get pointer FCNnCMRGSSPT with the corresponding FCNnCMRGRX register.

The RHL is undefined immediately after the transition of the FCN module from initialization mode to one of operating modes.

The FCNnCMLISTR register holds the contents of the RHL element indicated by the value of the FCNnCMLISTR.FCNnCMLISSLR[7:0] pointer minus 1. By reading the FCNnCMLISTR register, therefore, the number of the message buffer that received and stored a data frame or remote frame last can be checked. The FCNnCMLISSLR[7:0] pointer is used as a write pointer that indicates to what part of the RHL a message buffer number is recorded. Each time a data frame or remote frame is received and stored, the corresponding message buffer number is recorded to the RHL element indicated by the FCNnCMLISSLR[7:0] pointer. Each time recording to the RHL has been completed, the FCNnCMLISSLR[7:0] pointer is automatically incremented. In this way, the number of the message buffer that has received and stored a frame is chronologically recorded.

For message buffers where the FCNnMmCTL.FCNnMmNHMF flag is set, no entry in the receive history list is recorded.

The FCNnCMRGRX.FCNnCMRGSSPT pointer is used as a read pointer that reads a recorded message buffer number from the RHL. This pointer indicates the first RHL element that the CPU has not read yet. By reading the FCNnCMRGRX register by software, the number of a message buffer that has received and stored a data frame or remote frame can be read. Each time a message buffer number is read from the FCNnCMRGRX register, the FCNnCMRGSSPT pointer is automatically incremented.

If the FCNnCMRGRX.FCNnCMRGSSPT pointer value matches the FCNnCMLISTR.FCNnCMLISSLR[7:0] pointer value, FCNnCMRGRX.FCNnCMRGSSPM (receive history list pointer match) is set to 1. This indicates that no message buffer number that has not been read remains in the RHL. If a new message buffer number is recorded, the FCNnCMLISSLR[7:0] pointer is incremented and because its value no longer matches the FCNnCMRGSSPT pointer value, FCNnCMRGSSPM is cleared. In other words, the numbers of the unread message buffers exist in the RHL.

If the FCNnCMLISTR.FCNnCMLISSLR[7:0] pointer is incremented and matches the value of the FCNnCMRGRX.FCNnCMRGSSPT pointer minus 1, FCNnCMRGRX.FCNnCMRGRVFF (receive history list overflow) is set to 1. This indicates that the RHL is full of numbers of message buffers that have not been read. When further message reception and storing occur, the last recorded message buffer number is overwritten by the number of the message buffer that received and stored the newly received message. In this case, after FCNnCMRGRVFF has been set to 1, the recorded message buffer numbers in the RHL do not completely reflect the chronological order. However, messages are not lost and can be located by CPU search in message buffer memory with the help of FCNnMmCTL.FCNnMmDTNF, or by reading the FCN global registers FCNnDNBMRX0.

Caution Even if the receive history list is in the overflow state (FCNnCMRGRX.FCNnCMRGRVFF is set), the receive history list contents can still be read until the history list is empty (indicated by FCNnCMRGRX.FCNnCMRGSSPM flag set). Nevertheless, the receive history list remains in the overflow state, until FCNnCMRGRVFF is cleared by software. Unless FCNnCMRGRVFF is cleared, the FCNnCMRGSSPM flag is also not updated (cleared) upon a message storage of a newly received frame. This may lead to the situation that FCNnCMRGSSPM indicates an empty receive history list, although a reception has taken place, while the receive history list is in the overflow state (FCNnCMRGRVFF and FCNnCMRGSSPM are set).

As long as the RHL still has free entries, the sequence of reception is maintained. If more reception occurs before the RHL is read by the host processor, complete sequence of receptions cannot be recovered.

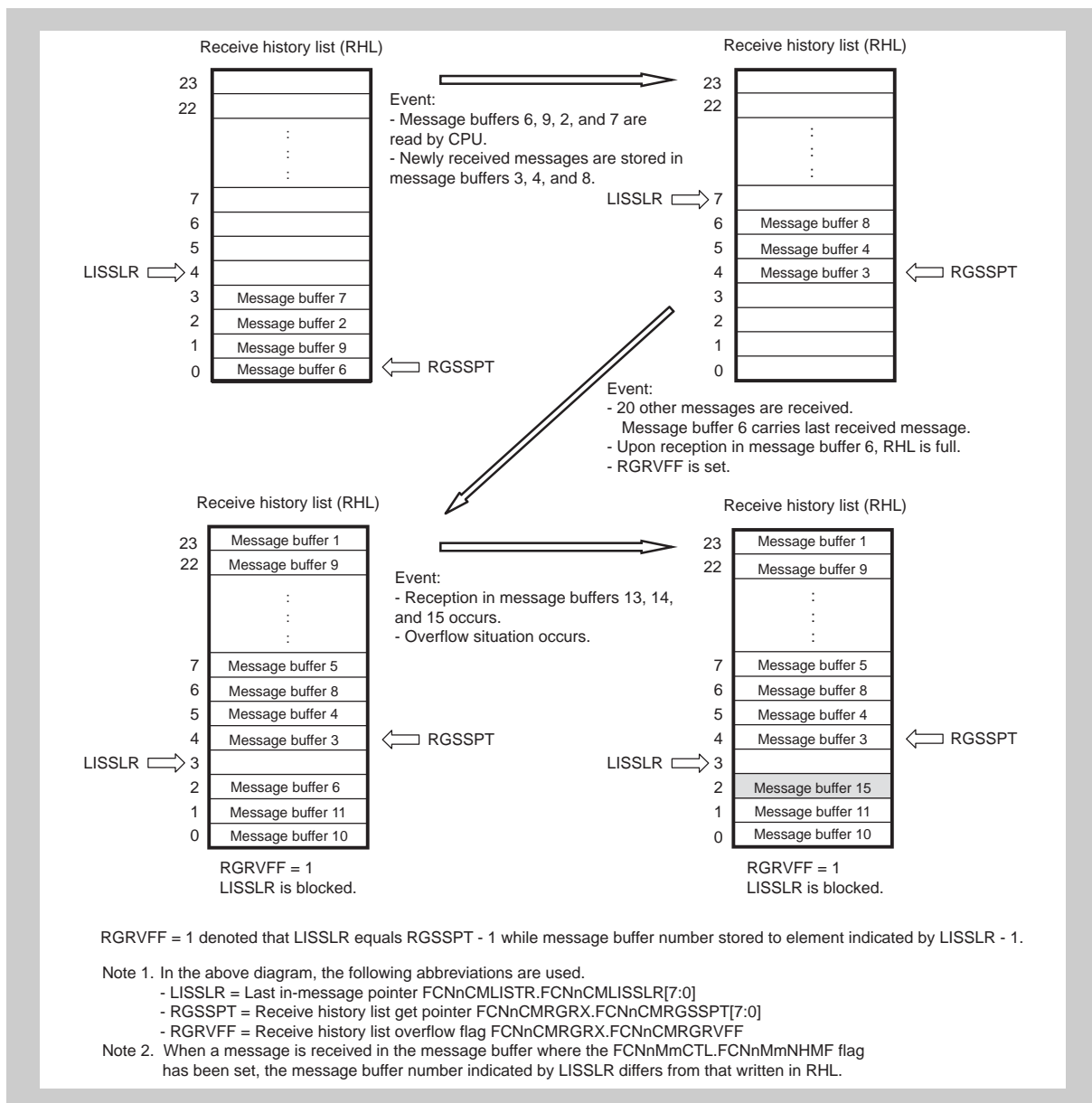

Figure 20-7 Receive History List

20.7.4 Mask Function

For any message buffer, which is used for reception, the assignment to one of eight global reception masks (or no mask) can be selected.

By using the mask function, the message ID comparison can be reduced by masked bits, herewith allowing the reception of several different IDs into one buffer.

While the mask function is enabled, an identifier bit that is defined to be 1 by a mask in the received message is not compared with the corresponding identifier bit in the message buffer.

However, this comparison is performed for any bit whose value is defined as 0 by the mask.

For example, let us assume that all messages that have a standard-format ID, in which bits ID27 to ID25 are 0 and bits ID24 and ID22 are 1, are to be stored in message buffer 14. The setting procedure for this example is shown below.

(1) Identifier to be Stored in Message Buffer

ID28	ID27	ID26	ID25	ID24	ID23	ID22	ID21	ID20	ID19	ID18
x	0	0	0	1	x	1	x	x	x	x

(2) Identifier to be Configured in Message Buffer 14 (Example) (Using FCN1M014MID0W Register)

ID28	ID27	ID26	ID25	ID24	ID23	ID22	ID21	ID20	ID19	ID18
x	0	0	0	1	x	1	x	x	x	x
ID17	ID16	ID15	ID14	ID13	ID12	ID11	ID10	ID9	ID8	ID7
x	x	x	x	x	x	x	x	x	x	x
ID6	ID5	ID4	ID3	ID2	ID1	ID0				
x	x	x	x	x	x	x				

Note 1. ID with the ID27 to ID25 bits cleared to 0 and the ID24 and ID22 bits set to 1 is registered (initialized) in message buffer 14.

Note 2. Message buffer 14 is set as a standard format identifier that is linked to mask 1 (FCN1M014STRB.FCN1M014SSMT[3:0] = 0010_B).

(3) FCN Module 1 Mask Setting (Mask 1)(Example) (Using FCN1 Module Mask 1 Register FCN1CMMKCTL01W)

FCN1CMMKSSID[..]										
ID28	ID27	ID26	ID25	ID24	ID23	ID22	ID21	ID20	ID19	ID18
1	0	0	0	0	1	0	1	1	1	1
ID17	ID16	ID15	ID14	ID13	ID12	ID11	ID10	ID9	ID8	ID7
1	1	1	1	1	1	1	1	1	1	1
ID6	ID5	ID4	ID3	ID2	ID1	ID0				
1	1	1	1	1	1	1				

1: Not compared (masked)

0: Compared

FCN1CMMKSSID[27:24] and FCN1CMMKSSID[22] are cleared to 0, and FCN1CMMKSSID[28], FCN1CMMKSSID[23], and FCN1CMMKSSID[21:0] are set to 1.

20.7.5 Multi Buffer Receive Block Function

The multi buffer receive block (MBRB) function is used to store a block of data in two or more message buffers sequentially with no CPU interaction, by setting the same ID to two or more message buffers with the same message buffer type. These message buffers can be allocated anywhere in the message buffer memory and need not be adjacent with each other.

Suppose, for example, the same message buffer type is set to 10 message buffers, message buffers 10 to 19, and the same ID is set to each message buffer. If the first message whose ID matches the ID of the message buffers is received, it is stored in message buffer 10. At this point, FCNnMmCTL.FCNnMmDTNF of message buffer 10 is set, prohibiting overwriting the message buffer when subsequent messages are received.

When the next message with a matching ID is received, it is received and stored in message buffer 11. Each time a message with a matching ID is received, it is sequentially (in the ascending order) stored in message buffers 12, 13, and so on. Even when a data block consisting of multiple messages is received, the messages can be stored and received without overwriting the previously received matching-ID data.

Whether a data block has been received and stored can be checked by setting FCNnMmCTL.FCNnMmIENF of each message buffer. For example, if a data block consists of k messages, k message buffers are initialized for reception of the data block. FCNnMmIENF in message buffers 0 to $(k-2)$ is cleared to 0 (interrupts disabled), and FCNnMmIENF in message buffer $k-1$ is set to 1 (interrupts enabled). In that case, a reception completion interrupt occurs when a message has been received and stored in message buffer $k-1$, indicating that MBRB has become full. Alternatively, by clearing FCNnMmIENF of message buffers 0 to $(k-3)$ and setting FCNnMmIENF of message buffer $k-2$, a warning that MBRB is about to overflow can be issued.

The basic conditions of storing receive data in each message buffer for the MBRB are the same as the conditions of storing data in a single message buffer.

-
- Caution 1. MBRB can be configured for each message buffer type. Therefore, even if a message buffer of another MBRB whose ID matches but whose message buffer type is different is empty, the received message is not stored in that message buffer, but instead discarded.
 - Caution 2. MBRB does not have a ring buffer structure. Therefore, after a message is stored in the message buffer having the highest number in the MBRB configuration, a newly received message will not be stored in the message buffer having the lowest message buffer number.
 - Caution 3. MBRB operates based on the reception and storage conditions. There are no settings dedicated to MBRB, such as function enable bits. By setting the same message buffer type and ID to two or more message buffers, MBRB is automatically configured.
 - Caution 4. Regarding MBRB, "matching ID" means "matching ID after mask". Even if the ID set to each message buffer is not the same, if the ID that is masked by the mask register matches, it is considered to be a matching ID and the buffer that has this ID is treated as the storage destination of a message.
 - Caution 5. For the priority between MBRBs, see Table 20-16, MBRB Priorities.
-

20.7.6 Remote Frame Reception

In all operating modes, when a remote frame is received, the message buffer that is to store the remote frame is searched from all the message buffers that meet the following conditions (1 and 2, condition 1 has priority on reception acceptance). If condition 1 is not met, the remaining message buffers are searched, whether condition 2 could be met.

- Condition 1:
Set as a transmit message buffer
(FCNnMmSTRB.FCNnMmSSMT[3:0] = 0000_B)
 - Used as a message buffer
(FCNnMmSTRB.FCNnMmSSAM = 1)
 - Ready for reception
(FCNnMmCTL.FCNnMmRDYF = 1)
 - Set for data frame message type
(FCNnMmSTRB.FCNnMmSSRT = 0)
 - Transmission request is not set.
(FCNnMmCTL.FCNnMmTRQF = 0)
- Condition 2:
Set as a receive message buffer
(FCNnMmSTRB.FCNnMmSSMT[3:0] = 0001_B ... 1001_B)
 - Used as a message buffer
(FCNnMmSTRB.FCNnMmSSAM = 1)
 - Ready for reception
(FCNnMmCTL.FCNnMmRDYF = 1)
 - Set for remote frame message type
(FCNnMmSTRB.FCNnMmSSRT = 1)
 - Buffer is ready to store a message.
(FCNnMmCTL.FCNnMmDTNF = 0, or FCNnMmSTRB.FCNnMmSSOW = 1 and FCNnMmCTL.FCNnMmDTNF = 1)

Upon reception of a remote frame, the following actions are executed if the ID of the received remote frame matches the ID of a message buffer that satisfies the above conditions.

- The FCNnMmDTLG[3:0] bits in the FCNnMmDTLGB register store the received DLC value.
- In reception to the transmit message buffer, the FCNnMmDAT0B to FCNnMmDAT7B registers in the data area are not updated (data before reception is saved).
- FCNnMmCTL.FCNnMmDTNF is set to 1.
- FCNnCMISCTL.FCNnCMISITSF1 is set to 1 (if FCNnMmCTL.FCNnMmIENF of the message buffer that receives and stores the frame is set to 1).
- The receive completion interrupt (INTCnREC) is output (if FCNnMmCTL.FCNnMmIENF of the message buffer that receives and stores the frame is set to 1 and if FCNnCMIECTL.FCNnCMIESEIE1 is set to 1).
- The message buffer number is recorded in the receive history list, if the FCNnMmCTL.FCNnMmNHMF flag is not set.

- Caution When a transmit message buffer is found for receiving and storing a remote frame, overwrite control by FCNnMmSTRB.FCNnMmSSOW of the message buffer and FCNnMmCTL.FCNnMmDTNF are not checked. The setting of FCNnMmSSOW is ignored, and FCNnMmDTNF is set in any case.
- Note 1. If two or more transmit message buffers have the same ID and the ID of the received remote frame matches that ID, the remote frame is stored in the transmit message buffer with the lowest message buffer number.
- Note 2. If transmit and receive message buffers are found, which can receive a remote frame matching with its ID, either masked or unmasked, the remote frame is stored in the transmit message buffer.
- Note 3. If there are receive message buffers that meet remote frame receiving conditions, the reception priority is identical to the data frame reception priority.
- Note 4. If a receive message buffer is found to match for a remote frame reception, and selected for storage, but this receive message buffer does not allow the storage, because FCNnMmDTNF is set and FCNnMmSSOW is not set, the remote frame is not stored at all.

20.8 Transmission of Message

20.8.1 Message Transmission

A message buffer with its FCNnMmCTL.FCNnMmTRQF bit set to 1 participates in the search for the most high-prioritized message when the following conditions are met. This processing is valid for all operating modes.

- Used as a message buffer
(FCNnMmSTRB.FCNnMmSSAM = 1)
- Set as a transmit message buffer
(FCNnMmSTRB.FCNnMmSSMT[3:0] = 0000_B)
- Ready for transmission
(FCNnMmCTL.FCNnMmRDYF = 1)

The CAN system is a multi-master communication system. In a system like this, the priority of message transmission is determined based on message identifiers (IDs). To facilitate transmission processing by software when there are several messages awaiting transmission, the FCN module uses hardware to check the ID of the message with the highest priority and automatically identifies that message. This eliminates the need for software-based priority control.

Transmission priority is controlled by the identifier (ID).

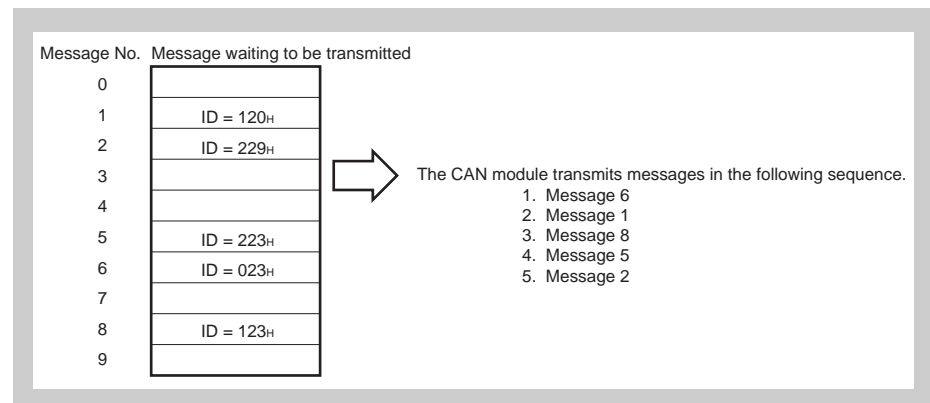

Figure 20-8 Example of Message Processing

After the transmit message search, the transmit message with the highest priority of the transmit message buffers that have a pending transmission request (message buffers with the FCNnMmCTL.FCNnMmTRQF bit set to 1 in advance) is transmitted.

If a new transmission request is set, the transmit message buffer with the new transmission request is compared with the transmit message buffer with a pending transmission request. If the new transmission request has a higher priority, it is transmitted, unless transmission of a message with a low priority has already started. If transmission of a message with a low priority has already started, however, the new transmission request is transmitted later. To solve this priority inversion problem, the software can perform a transmission abort request for the lower priority message. The priority order is determined according to the following rules.

Priority	Conditions	Description
1 (high)	Value of upper 11 bits of ID[ID28 to ID18]:	The message frame with the lowest value represented by the upper 11 bits of the ID is transmitted first. If the value of an 11-bit standard ID is equal to or smaller than the upper 11 bits of a 29-bit extended ID, the 11-bit standard ID has a higher priority than a message frame with a 29-bit extended ID.
2	Frame type	A data frame with an 11-bit standard ID (FCNnMmSTRB.FCNnMmSSRT cleared to 0) has a higher priority than a remote frame with a standard ID and a message frame with an extended ID.
3	ID type	A message frame with a standard ID (message buffer identifier register FCNnMmMID... bit FCNnMmSSIE is cleared to 0) has a higher priority than a message frame with an extended ID.
4	Value of lower 18 bits of ID[ID17 to ID0]:	If two or more transmission-pending extended ID message frames have equal values in the upper 11 bits of the ID and the same frame type (equal FCNnMmSTRB.FCNnMmSSRT bit values), the message frame with the lowest value in the lower 18 bits of its extended ID is transmitted first.
5 (low)	Message buffer number	If two or more message buffers request transmission of message frames with the same ID, the message from the message buffer with the lowest message buffer number is transmitted first.

Note 1. If the automatic block transmission request bit FCNnGMABCTL.FCNnGMABABTT is set to 1 in the normal operating mode with ABT, FCNnMmCTL.FCNnMmTRQF is set to 1 only for one message buffer in the ABT message buffer group.

If ABT mode is triggered by FCNnGMABCTL.FCNnGMABSEAT = 1, one FCNnMmCTL.FCNnMmTRQF is set to 1 in the ABT area (FCN: 0 to 7 of 32 message buffers). Beyond this transmit request, the application can request transmissions (set FCNnMmTRQF to 1) for other transmit message buffers that do not belong to the ABT area. In that case, an interval arbitration process (transmission search) evaluates all transmit message buffers with FCNnMmTRQF set to 1 and chooses the message buffer that contains the highest prioritized identifier for the next transmission. If there are two or more identifiers that have the highest priority (i.e. identical identifiers), the message located at the lowest message buffer number is transmitted first.

Upon successful transmission of a message frame, the following operations are performed.

- The FCNnMmCTL.FCNnMmTRQF flag of the corresponding transmit message buffer is automatically cleared to 0.
- The transmission completion status bit FCNnCMISCTL.FCNnCMISITSF0 is set to 1 (if the interrupt enable bit FCNnMmIENF of the corresponding transmit message buffer is set to 1).
- An interrupt request signal INTCnTRX is output (if FCNnCMIECTL.FCNnCMIESEIE0 is set to 1 and the interrupt enable bit FCNnMmIENF of the corresponding transmit message buffer is set to 1).

Note 2. When changing the contents of a transmit buffer, the FCNnMmCTL.FCNnMmRDYF flag of this buffer must be cleared before updating the buffer contents. Since the FCNnMmRDYF flag may be locked temporarily during internal transfer operation, the status of the FCNnMmRDYF flag must be checked by software after it is changed.

20.8.2 Transmit History List Function

The transmit history list (THL) function records in the transmit history list the number of the transmit message buffer from which data or remote frames have been sent. The THL consists of storage elements equivalent to up to 7 messages, the last out-message pointer FCNnCMLOSTR[7:0] with the corresponding FCNnCMLOSTR register, and the transmit history list get pointer FCNnCMTGSSPT[7:0] with the corresponding FCNnCMTGTX register.

The THL is undefined immediately after the transition of the FCN module from initialization mode to one of operating modes.

The FCNnCMLOSTR register holds the contents of the THL element indicated by the value of the FCNnCMLOSTR.FCNnCMLOSTR[7:0] pointer minus 1. By reading the FCNnCMLOSTR register, therefore, the number of the message buffer that transmitted a data frame or remote frame final can be checked. The FCNnCMLOSTR[7:0] pointer is utilized as a write pointer that indicates to what part of the THL a message buffer number is recorded. Any time a data frame or remote frame is transmitted, the corresponding message buffer number is recorded to the THL element indicated by the FCNnCMLOSTR[7:0] pointer. Each time recording to the THL has been completed, the FCNnCMLOSTR[7:0] pointer is automatically incremented. In this way, the number of the message buffer that has received and stored a frame will be recorded chronologically.

For message buffers where the FCNnMmCTL.FCNnMmNHMF flag is set, no entry in the history lists is recorded.

The FCNnCMTGTX.FCNnCMTGSSPT[7:0] pointer is used as a read pointer that reads a recorded message buffer number from the THL. This pointer indicates the first THL element that the CPU has not yet read. By reading the FCNnCMTGTX register by software, the number of a message buffer that has completed transmission can be read. Each time a message buffer number is read from the FCNnCMTGTX register, the FCNnCMTGSSPT[7:0] pointer is automatically incremented.

If the FCNnCMTGTX.FCNnCMTGSSPT[7:0] pointer value matches the FCNnCMLOSTR.FCNnCMLOSTR[7:0] pointer value, FCNnCMTGTX.FCNnCMTGSSPM (transmit history list pointer match) is set to 1. This indicates that no message buffer numbers that have not been read remain in the THL. If a new message buffer number is recorded, the FCNnCMLOSTR[7:0] pointer is incremented and because its value no longer matches the value of the FCNnCMTGSSPT[7:0] pointer, FCNnCMTGSSPM is cleared. In other words, the numbers of the unread message buffers exist in the THL.

If the FCNnCMLOSTR.FCNnCMLOSTR[7:0] pointer is incremented and matches the value of the FCNnCMTGTX.FCNnCMTGSSPT[7:0] pointer minus 1, FCNnCMTGTX.FCNnCMTGTVFF (transmit history list overflow) is set to 1. This indicates that the THL is full of message buffer numbers that have not been read. If a new message is received and stored, the message buffer number recorded last is overwritten by the message buffer number that transmitted its message afterwards. In that case, after FCNnCMTGTVFF has been set to 1, the recorded message buffer numbers in the THL do not completely reflect the chronological order. However, the CPU can identify the numbers of message buffers that have completed transmission by searching all transmit buffers (before re-setting transmission).

Regardless of the FCNnCMTGTX.FCNnCMTGTVFF value, 6 (32 message buffers), 14 (64 message buffers) or 30 (128 message buffers) transmit message buffer numbers are stored in the THL.

Caution If the transmit history list is in the overflow condition (FCNnCMTGTGX.FCNnCMTGTVFF is set), reading the transmit history list contents is still possible, until the history list is empty (indicated by FCNnCMTGTGX.FCNnCMTGSSPM flag set). Nevertheless, the transmit history list remains in the overflow condition until FCNnCMTGTVFF is cleared by software. If FCNnCMTGTVFF is not cleared, the FCNnCMTGTGX.FCNnCMTGSSPM flag is not updated (cleared) upon successful transmission of a new message. This may lead to the situation, that FCNnCMTGSSPM indicates an empty transmit history list, although a successful transmission has taken place, while the history list is in the overflow state (FCNnCMTGTVFF and FCNnCMTGSSPM are set).

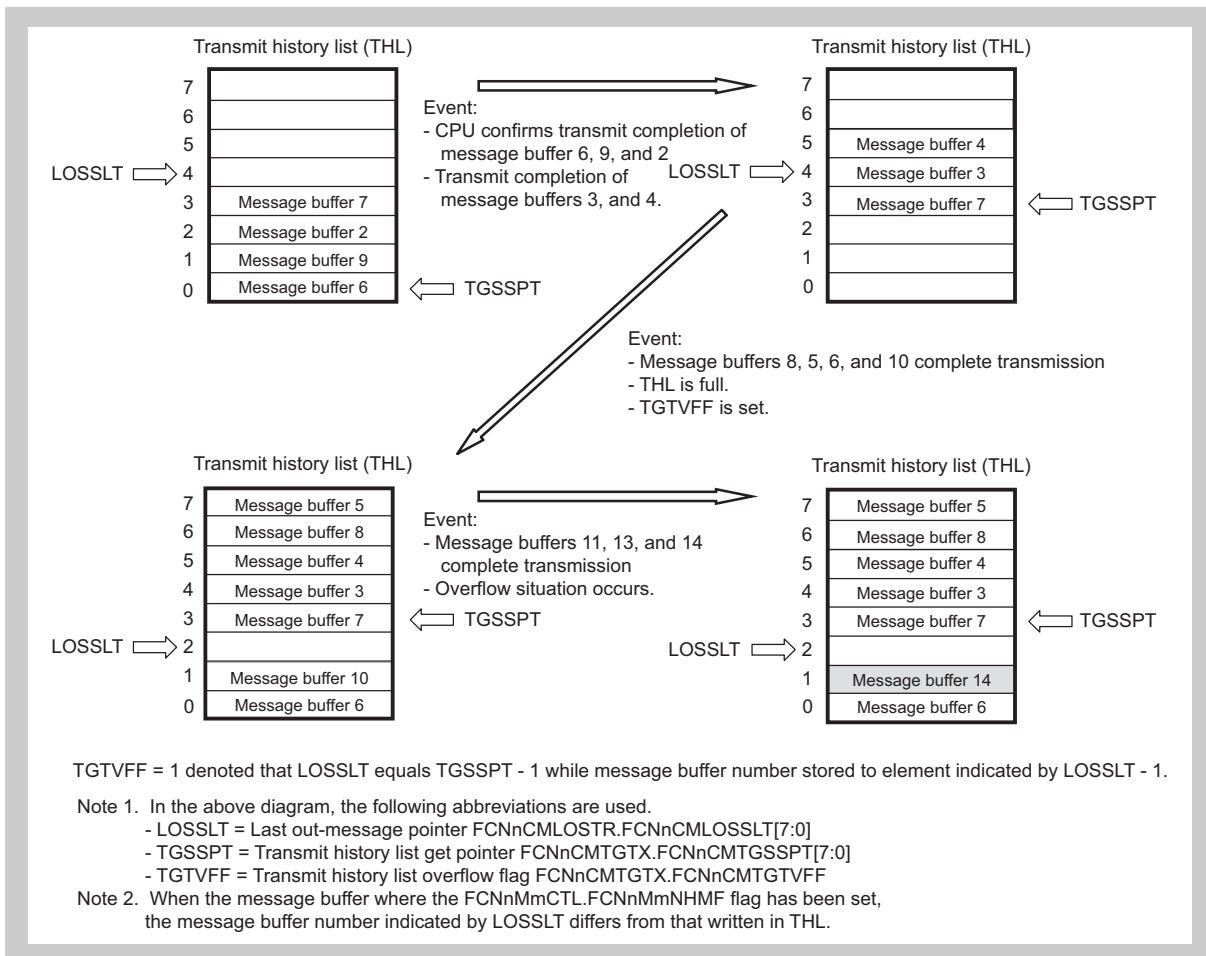

Figure 20-9 Transmit History List

20.8.3 Automatic Block Transmission (ABT)

The automatic block transmission (ABT) function is used to transmit two or more data frames successively with no CPU interaction. The maximum number of transmit message buffers assigned to the ABT function is 8. They are always assigned sequentially from the lowest message buffer number.

By setting FCNnCMCLCTL.FCNnCMCLMDOF[2:0] to 010_B, “normal operating mode with automatic block transmission function” (hereafter referred to as ABT mode) can be selected.

To issue an ABT transmission request, define the message buffers by software first. Set FCNnMmSTRB.FCNnMmSSAM to 1 in all the message buffers used for ABT, and define all the buffers as transmit message buffers by setting the FCNnMmSTRB.FCNnMmSSMT[3:0] bits to 0000_B. Be sure to set the same ID for the message buffers for ABT even when that ID is being used for all the message buffers. To use two or more IDs, set the ID of each message buffer by using the FCNnMmMID0H and FCNnMmMID1H or FCNnMmMID0W registers. Set the FCN message data byte registers before issuing a transmission request using the ABT function.

After initialization of message buffers for ABT is completed, FCNnMmCTL.FCNnMmRDYF needs to be set to 1. In ABT mode, FCNnMmCTL.FCNnMmTRQF does not have to be manipulated by software.

After the data for the ABT message buffers has been prepared, set FCNnGMABCTL.FCNnGMABSEAT to 1. Automatic block transmission is then started. When ABT is started, FCNnMmCTL.FCNnMmTRQF in the first message buffer (message buffer 0) is automatically set to 1. After transmission of the data of message buffer 0 is completed, the FCNnMmTRQF of the next message buffer, message buffer 1, is automatically set. In this way, transmission is performed successively.

A delay time can be inserted by the program in the interval in which the transmission request FCNnMmCTL.FCNnMmTRQF is automatically set while successive transmission is being executed. The delay time to be inserted is defined by the FCNnGMADCTL register. The unit of the delay time is DBT (data bit time). DBT depends on the settings of the FCNnCMBRPRS and FCNnCMBTCTL registers.

Among transmit objects in the ABT area, the priority of the transmission ID is not evaluated. The data of message buffers 0 to 7 are sequentially transmitted. When transmission of the data frame from the last message buffer has been completed, FCNnGMABCTL.FCNnGMABABTT is automatically cleared to 0 and the ABT operation is completed.

If there is a message buffer with the FCNnMmCTL.FCNnMmRDYF cleared in the ABT message buffer, during ABT, no data frame is transmitted from that buffer, ABT is suspended, and FCNnGMABCTL.FCNnGMABABTT is cleared. After that, transmission can be resumed from the message buffer where ABT stopped, by setting FCNnMmRDYF and FCNnGMABABTT to 1 by software. To not resume transmission from the message buffer where ABT stopped, set the FCNnGMABCTL.FCNnGMABCLRFB bit to 1 while ABT mode is stopped and FCNnGMABABTT is cleared to 0 to reset the internal ABT engine. In this case, transmission starts from message buffer 0 if FCNnGMABCTL.FCNnGMABSEAC is cleared to 0 and then FCNnGMABABTT is set to 1.

An interrupt can be used to check if data frames have been transmitted from all the message buffers for ABT. To do so, FCNnMmCTL.FCNnMmIENF of each message buffer except the last message buffer needs to be cleared to 0.

If a transmit message buffer other than those used by the ABT function is assigned to a transmit message buffer, the message to be transmitted next is determined by the priority of the transmission ID of the ABT message buffer whose transmission is currently held pending and the transmission ID of the message buffers that are not used by the ABT function.

Transmission of a data frame from an ABT message buffer is not recorded in the transmit history list (THL).

-
- Caution 1. Set FCNnGMABCTL.FCNnGMABSEAC to 1 while FCNnGMABCTL.FCNnGMABABTT is cleared to 0 in order to resume ABT operation at buffer No. 0. If FCNnGMABSEAC is set to 1 while FCNnGMABABTT is set to 1, the subsequent operation is not guaranteed.
- Caution 2. If the automatic block transmission engine is cleared by setting FCNnGMABCTL.FCNnGMABSEAC to 1, FCNnGMABSEAC is automatically cleared immediately after the processing of the clearing request is completed.
- Caution 3. Do not trigger automatic block transmission in initialization mode. If FCNnGMABCTL.FCNnGMABSEAC is set in initialization mode, the proper operation is not guaranteed after the mode is changed from initialization mode to ABT mode.
- Caution 4. Do not set FCNnMmCTL.FCNnMmTRQF of the ABT message buffers to 1 by software in normal operating mode with ABT. Otherwise, the operation is not guaranteed.
- Caution 5. The FCNnGMADCTL register is used to set the delay time that is inserted in the period from completion of the preceding ABT message to setting of FCNnMmCTL.FCNnMmTRQF for the next ABT message when the transmission requests are set in the order of message numbers for each message for ABT that is successively transmitted in ABT mode. The timing at which the messages are actually transmitted onto the CAN bus varies depending on the status of transmission from other stations and the status of the setting of the transmission request for messages other than ABT messages.
- Caution 6. If a transmission request is made for a message other than an ABT message and if no delay time is inserted in the interval in which transmission requests for ABT are automatically set (FCNnGMADCTL = 00_H), messages other than ABT messages may be transmitted regardless of the difference in priority from the ABT message.
- Caution 7. Do not clear FCNnMmCTL.FCNnMmRDYF to 0 when FCNnGMABCTL.FCNnGMABABTT = 1.
- Caution 8. If a message is received from another node while normal operating mode with ABT is active, the transmit message from the ABT area may be transmitted with a delay of one frame although the FCNnGMADCTL register is set to 00_H.
-

20.8.4 Transmission Abort Process

(1) Transmission Abort Process except for in Normal Operating Mode with Automatic Block Transmission (ABT)

The user can clear FCNnMmCTL.FCNnMmTRQF to 0 to abort a transmission request. FCNnMmTRQF will be cleared immediately when the abort is successful. Whether the transmission was successfully aborted or not can be checked by using FCNnCMCLCTL.FCNnCMCLSSTS and the FCNnCMTGTX register or the FCNnMmCTL.FCNnMmTCPF flag, which indicate the transmission status on the CAN bus (for details, see the procedure in Figure 20-24, Transmission Abort Processing (Except Normal Operating Mode with ABT)).

(2) Transmission Abort Process in Normal Operating Mode with Automatic Block Transmission (ABT)

To abort ABT that is already started, clear FCNnGMABCTL.FCNnGMABCLAT to 0. In this case, FCNnGMABCTL.FCNnGMABABTT remains 1 until the transmission is completed (successfully or not) if an ABT message is currently being transmitted, and is cleared to 0 as soon as transmission is completed. This aborts ABT.

If the last transmission (before ABT is aborted) is successful, the internal ABT pointer of the normal operating mode with ABT points to the next message buffer to be transmitted.

In the case of a failure in transmission, the position of the internal ABT pointer depends on the status of FCNnMmCTL.FCNnMmTRQF in the last transmitted message buffer. If FCNnMmTRQF is set to 1 when clearing FCNnGMABCTL.FCNnGMABABTT is requested, the internal ABT pointer points to the last transmitted message buffer. If FCNnMmTRQF is cleared to 0 when clearing FCNnGMABCTL.FCNnGMABABTT is requested, the internal ABT pointer is incremented (+1) and points to the next message buffer in the ABT area. (For details, see the procedure in Figure 20-27, ABT Transmission Request Abort Processing (Normal Operating Mode with ABT) (2)).

Caution Be sure to abort ABT by clearing FCNnGMABCTL.FCNnGMABABTT to 0. The operation is not guaranteed if aborting transmission is requested by clearing FCNnMmCTL.FCNnMmRDYF.

When normal operating mode with ABT is resumed after ABT has been aborted and FCNnGMABCTL.FCNnGMABSEAT is set to 1, the ABT message buffer to be transmitted next is determined from the following table.

Status of FCNnMmCTL.FCNnMmTR QF of ABT Message Buffer	Abort of ABT after Successful Transmission	Abort of ABT after Erroneous Transmission
Set to 1	Next message buffer in the ABT area *1	Same message buffer in the ABT area
Cleared to 0	Next message buffer in the ABT area *1	Next message buffer in the ABT area *1

Note 1. The above resumption operation can be performed only if a message buffer ready for ABT exists in the ABT area. For example, an abort request that is issued while ABT of highest ABT message buffer is in progress is regarded as completion of ABT, rather than abort, if transmission of this message buffer has been successfully completed, even if FCNnGMABCTL.FCNnGMABABTT is cleared to 0. If FCNnMmCTL.FCNnMmRDYF in the next message buffer in the ABT area is cleared to 0, the internal ABT pointer is retained, but the resumption operation is not performed even if FCNnGMABABTT is set to 1, and ABT ends immediately.

20.8.5 Remote Frame Transmission

Remote frames can be transmitted only from transmit message buffers. Set whether a data frame or remote frame is transmitted by using FCNnMmSTRB.FCNnMmSSRT. Setting FCNnMmSSRT to 1 sets remote frame transmission.

20.9 Power Save Modes

20.9.1 FCN Sleep Mode

FCN sleep mode can be used to set the CAN controller to standby mode in order to reduce power consumption. The FCN module can enter FCN sleep mode from all operating modes. Release of FCN sleep mode returns the FCN module to exactly the same operating mode from which FCN sleep mode was entered.

In FCN sleep mode, the FCN module does not transmit messages, even when transmission requests are issued or pending.

(1) Entering FCN Sleep Mode

The CPU issues an FCN sleep mode transition request by setting $\text{FCNnCMCLCTL.FCNnCMCLMDPF}[1:0] = 01_{\text{B}}$.

This transition request is acknowledged only under the following conditions.

1. The FCN module is already in one of the following operating modes.
 - Normal operating mode
 - Normal operating mode with ABT
 - Receive-only mode
 - Single-shot mode
 - Self-test mode
 - FCN stop mode in all above operating modes
2. The CAN bus state is bus idle (the fourth bit in the inter-frame space is recessive).
If the CAN bus is fixed to dominant, the request for transition to FCN sleep mode is held pending. Also the transition from FCN stop mode to FCN sleep mode is independent of the CAN bus state.
3. No transmission request is pending.
4. Do not use power save mode in combination with the operating mode change. Make these accesses in different steps.

Note If a sleep mode request is pending and at the same time a message is received in a message box, the sleep mode request is not cancelled, but is executed right after message storage has been completed. This may cause the FCN to enter sleep mode while the CPU is executing the reception interrupt routine. Therefore, the interrupt routine must check the access to the message buffers as well as receive history list registers by using the FCNnGMCLSSMO flag, if sleep mode is used.

If none of the above conditions is met, the FCN module will operate as follows.

- If FCN sleep mode is requested from initialization mode, the FCN sleep mode transition request is ignored and the FCN module remains in initialization mode.

- If the CAN bus state is not bus idle (i.e., the CAN bus state is either transmitting or receiving) when a transition to FCN sleep mode is requested from one of operating modes, immediate transition to FCN sleep mode is not possible. In this case, FCN sleep mode transition request is held pending until the CAN bus state becomes bus idle (the fourth bit in the inter-frame space is recessive). During the time period from the FCN sleep mode request to successful transition, FCNnCMCLCTL.FCNnCMCLMDPF[1:0] remain 00_B. When the module has entered FCN sleep mode, the FCNnCMCLMDPF[1:0] bits are set to 01_B.
- If a request for transition to initialization mode and a request for transition to FCN sleep mode are made at the same time while the FCN module is in one of operating modes, the request for initialization mode is enabled. The FCN module enters initialization mode at a predetermined timing. At this time, the FCN sleep mode request is not held pending and is ignored.
- Even when initialization mode and sleep mode are not requested simultaneously (i.e the first request has not been granted while the second request is made), the request for transition to initialization mode has priority over the sleep mode request. The sleep mode request is cancelled when the transition to initialization mode is requested. While a request for transition to initialization mode is pending, a subsequent request for sleep mode request is cancelled right at the point in time where it was issued.

(2) FCN Sleep Mode Status

The FCN module is in the following state after it enters FCN sleep mode.

- The internal operating clock stops and the power consumption is minimized.
- The function to detect the falling edge of the FCN reception pin (FCNnRX) remains in effect to wake up the FCN module from the CAN bus.
- To wake up the FCN module from the CPU, data can be set for FCNnCMCLCTL.FCNnCMCLMDPF[1:0], but nothing can be written to other FCN module registers or bits.
- FCN module registers can be read, except for the FCNnCMLISTR, FCNnCMRGRX, FCNnCMLOSTR, and FCNnCMTGTX registers.
- FCN message buffer registers cannot be written or read.
- FCNnGMCLCTL.FCNnGMCLSSMO is cleared.
- FCNnDNBMRX registers cannot be read.
- A request for transition to initialization mode is not acknowledged and is ignored.

(3) Releasing FCN Sleep Mode

FCN sleep mode is released by the following events.

- Setting FCNnCMCLCTL.FCNnCMCLMDPF[1:0] to 00_B by the CPU
- A falling edge of the FCN reception pin FCNnRX (i.e. the CAN bus level shifts from recessive to dominant)

Caution Even if the falling edge belongs to the SOF of a receive message, this message will not be received or stored. If the CPU stops supplying the clock to the FCN module while the FCN module is in sleep mode, FCN sleep mode will not be released and FCNnCMCLMDPF[1:0] will remain 01_B unless the clock to the FCN module is supplied again. In addition to this, the receive message will not be received after that.

After releasing sleep mode, the FCN module returns operating mode from which FCN sleep mode was requested. After that, FCNnCMCLCTL.FCNnCMCLCTL[1:0] must be reset to 00_B by software. If FCN sleep mode is released by a change in the CAN bus state, FCNnCMISCTL.FCNnCMISITSF5 is set to 1 regardless of FCNnCMIECTL.FCNnCMIEINTF[6:0]. After the FCN module is released from FCN sleep mode, it participates in the CAN bus communication again by automatically detecting 11 consecutive recessive-level bits on the CAN bus. The user application has to wait until FCNnGMCLCTL.FCNnGMCLSSMO = 1, before accessing message buffers again.

When a request for transition to initialization mode is made while the FCN module is in FCN sleep mode, the request is ignored. The FCN module has to be released from sleep mode first by software before entering initialization mode.

-
- Caution 1.** Note that the release of FCN sleep mode by CAN bus event, and thus the wake-up interrupt may happen at any time, even right after requesting transition to sleep mode, if a CAN bus event occurs.
- Caution 2.** Always reset the FCNnCMCLCTL.FCNnCMCLMDPF[1:0] bits to 00_B, when waking up from FCN sleep mode before accessing any other registers of the FCN module.
- Caution 3.** Always clear the interrupt flag FCNnCMISCTL.FCNnCMISITSF5, when waking up from FCN sleep mode.
-

20.9.2 FCN Stop Mode

FCN stop mode can be used to set the CAN controller to stand-by mode to reduce power consumption. The FCN module can enter FCN stop mode only from FCN sleep mode. Releasing FCN stop mode causes the FCN module to enter FCN sleep mode.

FCN stop mode can be released (entering FCN sleep mode) only by setting FCNnCMCLCTL.FCNnCMCLMDPF[1:0] to 01_B. FCN stop mode cannot be released by a change in the CAN bus state. No message is transmitted even when transmission requests are issued or pending.

(1) Entering FCN Stop Mode

A FCN stop mode transition request is issued by setting FCNnCMCLCTL.FCNnCMCLMDPF[1:0] to 11_B.

A FCN stop mode transition request is only acknowledged while the FCN module is in FCN sleep mode. In all other modes, the request is ignored.

Caution To set the FCN module to FCN stop mode, the module must be in FCN sleep mode. To confirm that the module is in sleep mode, check that the FCNnCMCLCTL.FCNnCMCLMDPF[1:0] = 01_B, and then request transition to FCN stop mode. If a bus change occurs at the FCN reception pin FCNnRX while this process is being performed, FCN sleep mode is automatically released. In this case, the FCN stop mode transition request is not acknowledged.

(2) FCN Stop Mode Status

The FCN module is in the following state after it enters FCN stop mode.

- The internal operating clock stops and the power consumption is minimized.
- To wake up the FCN module from the CPU, data can be set to FCNnCMCLCTL.FCNnCMCLMDPF[1:0], but nothing can be written to other FCN module registers or bits.
- FCN module registers can be read, except for the FCNnCMLISTR, FCNnCMRGRX, FCNnCMLOSTR, and FCNnCMTGTX registers.
- FCN message buffer registers cannot be written or read.
- FCNnGMCLCTL.FCNnGMCLSSMO is cleared.
- FCNnDNBMRX registers cannot be read.
- An initialization mode transition request is not acknowledged and is ignored.

(3) Releasing FCN Stop Mode

FCN stop mode can be released only by writing 01_B to FCNnCMCLCTL.FCNnCMCLMDPF[1:0]. After releasing FCN stop mode, the FCN module enters FCN sleep mode.

When transition to initialization mode is requested while the FCN module is in FCN stop mode, the request is ignored. The CPU has to release stop mode and then release the FCN sleep mode before entering initialization mode. It is impossible to enter another operating mode directly from FCN stop mode not entering FCN sleep mode. Such request is ignored.

20.9.3 Example of Using Power Save Modes

In some application systems, it may be necessary to place the CPU in a power save mode to reduce power consumption. By using power save mode specific to the FCN module and power save mode specific to the CPU in combination, the CPU can be woken up from the power save status by the CAN bus.

The following shows an example for using power save modes.

- First, put the FCN module in FCN sleep mode (FCNnCMCLCTL.FCNnCMCLMDPF[1:0] = 01_B).
After successfully confirming this state by reading the sleep mode status, put the CPU in power save mode. Disable interrupts to the CPU, while processing additional tasks after the FCN module has entered sleep mode to avoid the FCN wake-up interrupt from being acknowledged.
If an edge transition from recessive to dominant is detected at the FCN reception pin FCNnRX in this state, FCNnCMISCTL.FCNnCMISITSF5 in the FCN module is set to 1. When FCNnCMIECTL.FCNnCMIEINT5 is set to 1, a wake-up interrupt (INTnWUP) is generated.
The FCN module is automatically released from FCN sleep mode (FCNnCMCLMDPF[1:0] = 00_B) and returns to normal operating mode.
- The CPU, in response to INTnWUP, can release its own power save mode and return to normal operating mode.

To further reduce the power consumption of the CPU, the internal clock - including that of the FCN module - may be stopped. In this case, the operating clock supplied to the FCN module stops after the FCN module has entered FCN sleep mode. Then, the CPU enters a power save mode in which the clock supplied to the CPU is stopped.
- If an edge transition from recessive to dominant is detected at the FCN reception pin FCNnRX in this state, the FCN module can set FCNnCMISCTL.FCNnCMISITSF5 to 1 and generate a wake-up interrupt INTnWUP even if it is not supplied with the clock.
- However, other functions do not operate because clock supply to the FCN module is stopped, and the module remains in FCN sleep mode.
- The CPU, in response to INTnWUP,
 - releases its power save mode,
 - resumes supply of the internal clocks - including the clock to the FCN module - after the oscillation stabilization time has elapsed, and
 - starts instruction execution.
- When clock supply is resumed, the FCN module is immediately released from FCN sleep mode and returns to normal operating mode (FCNnCMCLCTL.FCNnCMCLMDPF[1:0] = 00_B).

20.10 Interrupt Function

The FCN module provides seven different interrupt sources.

The occurrence of these interrupt sources is stored in the interrupt status register. Four separate interrupt request signals are generated from the seven interrupt sources. When an interrupt request signal that corresponds to two or more interrupt sources is generated, the interrupt sources can be identified by using the interrupt status register. After an interrupt source has occurred, the corresponding interrupt status bit must be cleared to 0 by software.

Table 20-17 List of FCN Module Interrupt Sources

No.	Interrupt Status FCNnCMISCTL.	Interrupt Enable FCNnCMIESEIE.* ¹	Interrupt Request Signal	Description of Interrupt Source
1	FCNnCMISITSF0	FCNnCMIESEIE0	INTnTRX	Message frame successfully transmitted from message buffer m
2	FCNnCMISITSF1	FCNnCMIESEIE1	INTnREC	Valid message frame reception in message buffer m
3	FCNnCMISITSF2	FCNnCMIESEIE2	INTnERR	FCN module error state interrupt <ul style="list-style-type: none"> This interrupt is generated when the transmission/reception error counter is at the warning level, or in the error passive or bus-off state.
4	FCNnCMISITSF3	FCNnCMIESEIE3		FCN module protocol error interrupt <ul style="list-style-type: none"> This interrupt is generated when a stuff error, form error, ACK error, bit error, or CRC error occurs.
5	FCNnCMISITSF4	FCNnCMIESEIE4		FCN module arbitration loss interrupt
6	FCNnCMISITSF5	FCNnCMIESEIE5	INTnWUP	FCN module wake-up interrupt from FCN sleep mode <ul style="list-style-type: none"> This interrupt is generated when the FCN module is woken up from FCN sleep mode because a falling edge is detected at the FCN reception pin (CAN bus transition from recessive to dominant).
7	FCNnCMISITSF6	FCNnCMIESEIE6		FCN module transmission abort interrupt status <ul style="list-style-type: none"> This interrupt is generated when transmission was successfully aborted (aborted message was not sent).

Note 1. The message buffer interrupt enable bit FCNnMmCTL.FCNnMmiENF of the corresponding message buffer must be set to 1 for that message buffer to participate in the interrupt generation process.

20.11 Diagnosis Functions and Special Operating Modes

The FCN module provides a receive-only mode, single-shot mode, and self-test mode to support CAN bus diagnosis functions or the operation of special CAN communication methods.

20.11.1 Receive-only Mode

Receive-only mode is used to monitor receive messages without causing any interference on the CAN bus and can be used for CAN bus analysis nodes.

For example, this mode can be used for automatic baud-rate detection. The baud rate of the FCN module changes until “valid reception” is detected, so that the baud rates in the module match (“valid reception” means that a message frame has been received in the CAN protocol layer without occurrence of an error and with an appropriate ACK between nodes connected to the CAN bus). A valid reception does not require message frames to be stored in a receive message buffer (data frames) or transmit message buffer (remote frames). A valid reception event is indicated and confirmed by setting FCNnCMCLCTL.FCNnCMCLVALF to 1.

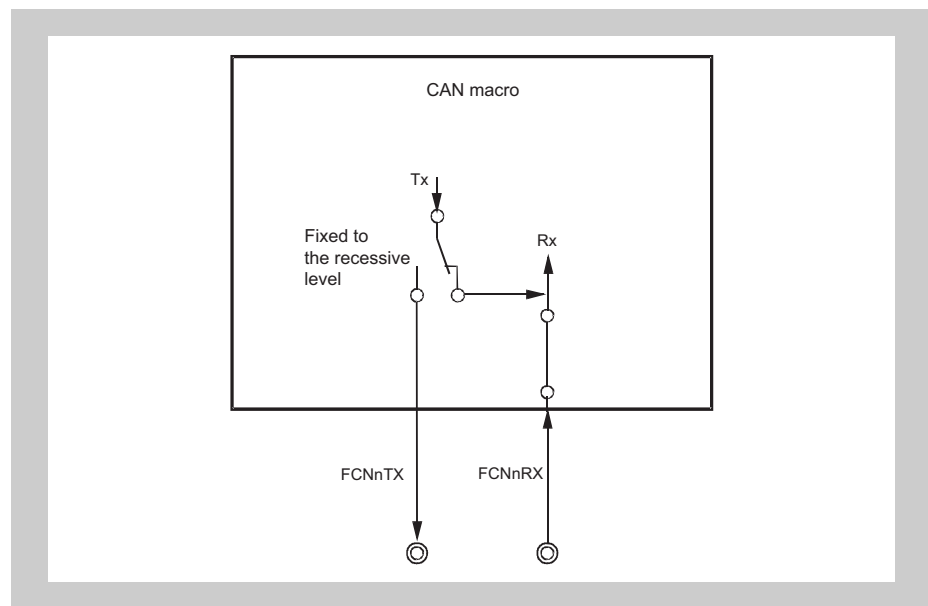

Figure 20-10 FCN Module Pin Connection in Receive-only Mode

In receive-only mode, no message frames can be transmitted from the FCN module to the CAN bus. Transmit requests issued to message buffers defined as transmit message buffers are held pending.

In receive-only mode, the FCN transmission pin FCNnTX of the FCN module is fixed to the recessive level. Therefore, no active error flag can be transmitted from the FCN module to the CAN bus even when a CAN bus error is detected while receiving a message frame. Since the FCN module cannot send data, the transmission error counter the FCNnCMERCNT.TEC7 to FCNnCMERCNT.TEC0 bits are never updated. Therefore, the FCN module in receive-only mode does not enter the bus-off state.

Furthermore, in receive-only mode, ACK is not returned to the CAN bus upon the valid reception of a message frame. Internally, the local node recognizes that it has transmitted ACK. No overload frame can be transmitted to the CAN bus.

Caution If only two CAN nodes are connected to the CAN bus and one of them is operating in receive-only mode, no ACK is transmitted to the CAN bus. Due to the missing ACK, the transmitting node transmits an active error flag and repeat transmitting a message frame. The transmitting node becomes error passive after transmitting the message frame 16 times (assuming that the error counter was 0 in the beginning and no other errors have occurred). After the 17th message frame is transmitted, the transmitting node generates a passive error flag. The receiving node in receive-only mode detects a valid message frame for the first time at this point, and the FCNnCMCLCTL.FCNnCMCLVALF bit is set to 1 for the first time.

20.11.2 Single-shot Mode

In single-shot mode, automatic re-transmission as defined in the CAN protocol is switched off. (According to the CAN protocol, a message frame transmission that has been aborted by either arbitration loss or error occurrence has to be repeated without control by software.) All other operations of single shot-mode are identical to normal operating mode. Features of single-shot mode cannot be used in combination with normal operating mode with ABT.

Single-shot mode disables the re-transmission of an aborted message frame according to the setting of FCNnCMCLCTL.FCNnCMCLALBF. When FCNnCMCLALBF is cleared to 0, re-transmission upon arbitration loss and upon error occurrence is disabled. If FCNnCMCLALBF is set to 1, re-transmission upon error occurrence is disabled, but re-transmission upon arbitration loss is enabled. As a consequence, FCNnMmCTL.FCNnMmTRQF in a message buffer defined as a transmit message buffer is cleared to 0 by the following events.

- Successful transmission of the message frame
- Arbitration loss while sending a message frame
- Error occurrence while sending a message frame

Arbitration loss and error occurrence events can be distinguished by checking FCNnCMISCTL.FCNnCMISITSF4 and FCNnCMISCTL.FCNnCMISITSF3 respectively, and the type of the error can be identified by reading FCNnCMLCSTR.FCNnCMCSSL[2:0].

Upon successful transmission of a message frame, the transmit completion interrupt bit FCNnCMISCTL.FCNnCMISITSF0 is set to 1. When FCNnCMIECTL.FCNnCMIEINTF0 is set to 1 at this time, an interrupt request signal is output.

Single-shot mode can be used for emulating time-triggered communication methods (e.g. TTCAN level 1).

Caution FCNnCMCLCTL.FCNnCMCLALBF is only valid in single-shot mode. It does not affect the re-transmission upon occurrence of arbitration loss in other operating modes.

20.11.3 Self-test Mode

In self-test mode, message frame transmission and reception can be tested without connecting the CAN node to the CAN bus or without affecting the CAN bus.

In self-test mode, the FCN module is completely disconnected from the CAN bus and transmission and reception are internally looped back. The FCN transmission pin FCNnTX is fixed to the recessive level.

If the falling edge on the FCN reception pin FCNnRX is detected after the FCN module has entered FCN sleep mode from self-test mode, however, the module is released from the FCN sleep mode in the same manner as the other operating modes. To keep the module in FCN sleep mode, use the FCN reception pin FCNnRX as a port pin.

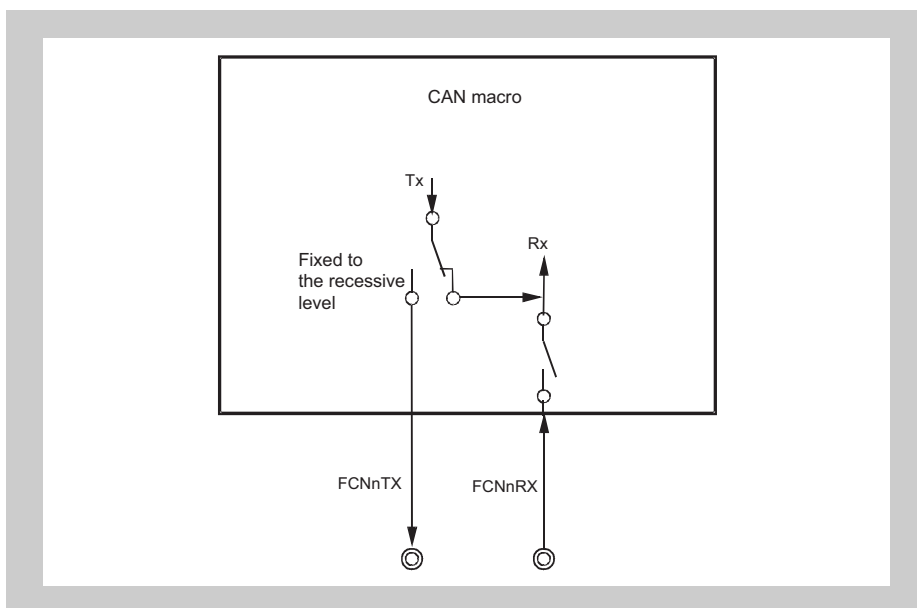

Figure 20-11 FCN Module Pin Connection in Self-test Mode

20.11.4 Receive/Transmit Operations in Each Operating Mode

The following table shows outline of the receive/transmit operations in each operating mode.

Table 20-18 Outline of Receive/Transmit Operations in Each Operating Mode

Operating Mode	Transmission of Data/Remote Frame	Transmission of ACK	Transmission of Error/Overload Frame	Transmission Retry	Automatic Block Transmission (ABT)	FCNnCMCLVALF Setting	Store Data to Message Buffer
Initialization mode	Disabled	Disabled	Disabled	Disabled	Disabled	Disabled	Disabled
Normal operating mode	Enabled	Enabled	Enabled	Enabled	Disabled	Enabled	Enabled
Normal operating mode with ABT	Enabled	Enabled	Enabled	Enabled	Enabled	Enabled	Enabled
Receive-only mode	Disabled	Disabled	Disabled	Disabled	Disabled	Enabled	Enabled
Single-shot mode	Enabled	Enabled	Enabled	Disabled *1	Disabled	Enabled	Enabled
Self-test mode	Enabled *2	Enabled *2	Enabled *2	Enabled*2	Disabled	Enabled *2	Enabled *2

Note 1. When the arbitration loss occurs, control of re-transmission is possible by FCNnCMCLCTL.FCNnCMCLALBF.

Note 2. Signals to be generated are not output to outside, but remain in the FCN module.

20.12 Time Stamp Function

CAN is an asynchronous serial protocol. All nodes connected to the CAN bus have a local, autonomous clock. As a consequence, the clocks of nodes have no relation (i.e., the clocks are asynchronous and may have different frequencies depending on nodes).

In some applications, however, a common time base over the network (= global time base) is needed. In order to build up a global time base, a time stamp function is used. The essential mechanism of a time stamp function is the capture of timer values triggered by signals on the CAN bus.

20.12.1 Time Stamp Function

The CAN controller supports the capturing of timer values triggered by a specific frame. This product uses the CAN controller and 8ch and 9ch of TAUB0 in combination. (For details, see Section 24.4.9, CAN Time Stamp Function.)

The 8ch and 9ch of TAUB0 capture timer values according to the capturing trigger signal (TSOUT) that is output when a data frame from the CAN controller is received. The CPU can retrieve the time of occurrence of the capture event, i.e., the time stamp of the message received from the CAN bus, by reading the captured value. The TSOUT signal can be selected from the following two event sources and is specified by FCNnCMTSCTL.FCNnCMTSSELE.

- SOF event (start of frame)
(FCNnCMTSCTL.FCNnCMTSSELE = 0)
- EOF event (last bit of end of frame)
(FCNnCMTSCTL.FCNnCMTSSELE = 1)

The TSOUT signal is enabled by setting FCNnCMTSCTL.FCNnCMTSTSGE to 1.

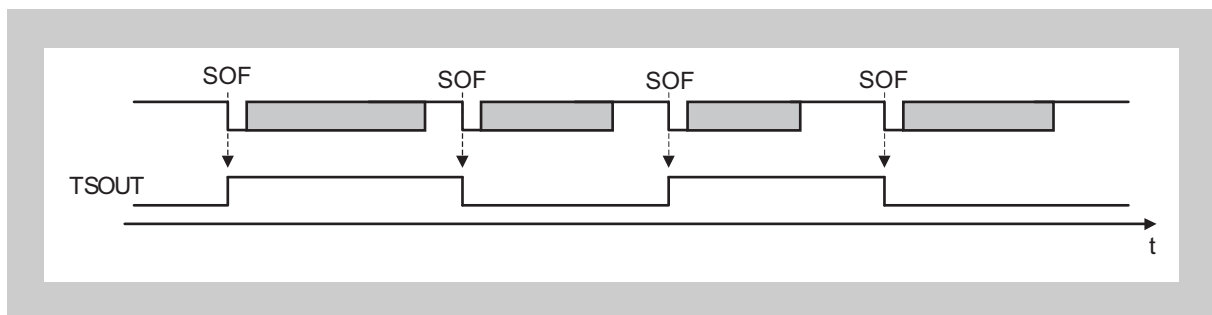

Figure 20-12 Timing Chart of Capture Signal TSOUT

The TSOUT signal toggles its level upon occurrence of the selected event during data frame reception (in Figure 20-12, Timing Chart of Capture Signal TSOUT, the SOF is used as the trigger event source). To capture a timer value by using the TSOUT signal, the capture timer unit must detect the capture signal at both the rising edge and falling edge.

This time stamp function is controlled by the FCNnCMTSLOKE bit of the FCNnCMTSCTL register. When FCNnCMTSLOKE is cleared to 0, the TSOUT signal toggles upon occurrence of the selected event. When FCNnCMTSLOKE is set to 1, the TSOUT signal toggles upon occurrence of the selected event, but the toggle stops as FCNnCMTSCTL.FCNnCMTSTSGE is automatically cleared to 0 as soon as the message storing to the message buffer 0 starts. This suppresses the subsequent toggle occurrence by the TSOUT signal, so that the time stamp value toggled last (= captured last) can be saved as the time stamp value of the time at which the data frame was received in message buffer 0.

Caution The time stamp function using the FCNnCMTSLOKE bit stops toggle of the TSOUT signal by receiving a data frame in message buffer 0. Toggle of the TSOUT signal does not stop when a data frame is received in a message buffer other than message buffer 0.

A data frame cannot be received in message buffer 0 when the FCN module is in normal operating mode with ABT, because message buffer 0 must be set as a transmit message buffer.

In this operating mode, therefore, the function to stop toggle of the TSOUT signal by the FCNnCMTSLOKE bit cannot be used.

20.13 Baud Rate Settings

20.13.1 Baud Rate Setting Conditions

Make sure that the settings are within the range of limit values shown below for ensuring correct operation of the CAN controller.

- $5 TQ \leq SPT$ (sampling point) $\leq 17 TQ$
 $SPT = TSEG1 + 1$
- $8 TQ \leq DBT$ (data bit time) $\leq 25 TQ$
 $DBT = TSEG1 + TSEG2 + 1 TQ = TSEG2 + SPT$
- $1 TQ \leq SJW$ (synchronization jump width) $\leq 4 TQ$
 $SJW \leq DBT - SPT$
- $4 \leq TSEG1 \leq 16$
- $1 \leq TSEG2 \leq 8$

Note 1. $TQ = 1/f_{TQ}$ (f_{TQ} : CAN protocol layer reference system clock)

Note 2. The values TSEG1, TSEG2, and SJW are defined by the following register bits.

$$TSEG1 = FCNnCBMCTL.FCnCBMBS1LG[3:0] + 1$$

$$TSEG2 = FCNnCBMCTL.FCnCBMBS2LG[2:0] + 1$$

$$SJW = FCNnCBMCTL.FCnCBMTJWL[1:0] + 1$$

Table 20-19, Settable Bit-Rate Combinations, shows combinations of bit rates that meet the above conditions.

Table 20-19 Settable Bit-Rate Combinations (1/3)

Valid Bit-Rate Setting					FCNnCBMCTL Setting Value		Sampling Point (Unit: %)
DBT Length	SYNC SEGMENT	PROP SEGMENT	PHASE SEGMENT 1	PHASE SEGMENT 2	FCNnCBMBS1LG [3:0]	FCNnCBMBS2LG [2:0]	
25	1	8	8	8	1111	111	68.0
24	1	7	8	8	1110	111	66.7
24	1	9	7	7	1111	110	70.8
23	1	6	8	8	1101	111	65.2
23	1	8	7	7	1110	110	69.6
23	1	10	6	6	1111	101	73.9
22	1	5	8	8	1100	111	63.6
22	1	7	7	7	1101	110	68.2
22	1	9	6	6	1110	101	72.7
22	1	11	5	5	1111	100	77.3
21	1	4	8	8	1011	111	61.9
21	1	6	7	7	1100	110	66.7
21	1	8	6	6	1101	101	71.4
21	1	10	5	5	1110	100	76.2
21	1	12	4	4	1111	011	81.0
20	1	3	8	8	1010	111	60.0

Table 20-19 Settable Bit-Rate Combinations (2/3)

Valid Bit-Rate Setting					FCNnCMBTCTL Setting Value		Sampling Point (Unit: %)
DBT Length	SYNC SEGMENT	PROP SEGMENT	PHASE SEGMENT 1	PHASE SEGMENT 2	FCNnCMBTS1LG [3:0]	FCNnCMBTS2LG [2:0]	
20	1	5	7	7	1011	110	65.0
20	1	7	6	6	1100	101	70.0
20	1	9	5	5	1101	100	75.0
20	1	11	4	4	1110	011	80.0
20	1	13	3	3	1111	010	85.0
19	1	2	8	8	1001	111	57.9
19	1	4	7	7	1010	110	63.2
19	1	6	6	6	1011	101	68.4
19	1	8	5	5	1100	100	73.7
19	1	10	4	4	1101	011	78.9
19	1	12	3	3	1110	010	84.2
19	1	14	2	2	1111	001	89.5
18	1	1	8	8	1000	111	55.6
18	1	3	7	7	1001	110	61.1
18	1	5	6	6	1010	101	66.7
18	1	7	5	5	1011	100	72.2
18	1	9	4	4	1100	011	77.8
18	1	11	3	3	1101	010	83.3
18	1	13	2	2	1110	001	88.9
18	1	15	1	1	1111	000	94.4
17	1	2	7	7	1000	110	58.8
17	1	4	6	6	1001	101	64.7
17	1	6	5	5	1010	100	70.6
17	1	8	4	4	1011	011	76.5
17	1	10	3	3	1100	010	82.4
17	1	12	2	2	1101	001	88.2
17	1	14	1	1	1110	000	94.1
16	1	1	7	7	0111	110	56.3
16	1	3	6	6	1000	101	62.5
16	1	5	5	5	1001	100	68.8
16	1	7	4	4	1010	011	75.0
16	1	9	3	3	1011	010	81.3
16	1	11	2	2	1100	001	87.5
16	1	13	1	1	1101	000	93.8
15	1	2	6	6	0111	101	60.0
15	1	4	5	5	1000	100	66.7
15	1	6	4	4	1001	011	73.3
15	1	8	3	3	1010	010	80.0
15	1	10	2	2	1011	001	86.7
15	1	12	1	1	1100	000	93.3
14	1	1	6	6	0110	101	57.1
14	1	3	5	5	0111	100	64.3
14	1	5	4	4	1000	011	71.4

Table 20-19 Settable Bit-Rate Combinations (3/3)

Valid Bit-Rate Setting					FCNnCMBTCTL Setting Value		Sampling Point (Unit: %)
DBT Length	SYNC SEGMENT	PROP SEGMENT	PHASE SEGMENT 1	PHASE SEGMENT 2	FCNnCMBTS1LG [3:0]	FCNnCMBTS2LG [2:0]	
14	1	7	3	3	1001	010	78.6
14	1	9	2	2	1010	001	85.7
14	1	11	1	1	1011	000	92.9
13	1	2	5	5	0110	100	61.5
13	1	4	4	4	0111	011	69.2
13	1	6	3	3	1000	010	76.9
13	1	8	2	2	1001	001	84.6
13	1	10	1	1	1010	000	92.3
12	1	1	5	5	0101	100	58.3
12	1	3	4	4	0110	011	66.7
12	1	5	3	3	0111	010	75.0
12	1	7	2	2	1000	001	83.3
12	1	9	1	1	1001	000	91.7
11	1	2	4	4	0101	011	63.6
11	1	4	3	3	0110	010	72.7
11	1	6	2	2	0111	001	81.8
11	1	8	1	1	1000	000	90.9
10	1	1	4	4	0100	011	60.0
10	1	3	3	3	0101	010	70.0
10	1	5	2	2	0110	001	80.0
10	1	7	1	1	0111	000	90.0
9	1	2	3	3	0100	010	66.7
9	1	4	2	2	0101	001	77.8
9	1	6	1	1	0110	000	88.9
8	1	1	3	3	0011	010	62.5
8	1	3	2	2	0100	001	75.0
8	1	5	1	1	0101	000	87.5
7*1	1	2	2	2	0011	001	71.4
7*1	1	4	1	1	0100	000	85.7
6*1	1	1	2	2	0010	001	66.7
6*1	1	3	1	1	0011	000	83.3
5*1	1	2	1	1	0010	000	80.0
4*1	1	1	1	1	0001	000	75.0

Note 1. Setting with a DBT value of 7 or less is valid only when the FCNnCMBRPRS register value is not 00_H.

Caution The values in Table 20-19, Settable Bit-Rate Combinations, do not guarantee the operation of the network system. Thoroughly check the effects of set values on the network system, considering oscillation errors and delays of the CAN bus and CAN transceiver.

20.13.2 Typical Examples of Baud Rate Settings

Table 20-20, Typical Examples of Baud Rate Settings ($f_{CANMOD} = 8 \text{ MHz}$), and Table 20-21, Typical Examples of Baud Rate Settings ($f_{CANMOD} = 16 \text{ MHz}$), show typical examples of baud rate settings.

Table 20-20 Typical Examples of Baud Rate Settings ($f_{CANMOD} = 8 \text{ MHz}$) (1/2)

Baud Rate Setting Value (unit: kbps)	Division Ratio of FCNnCM BRPRS	FCNnCM BRPRS Setting Value	Valid Bit-Rate Setting (Unit: TQ)					FCNnCM BTCTL Setting Value		Sampling Point (Unit: %)
			DBT Length	SYNC SEGMENT	PROP SEGMENT	PHASE SEGMENT 1	PHASE SEGMENT 2	FCNnCM BTS1LG [3:0]	FCNnCM BTS2LG [2:0]	
500	1	00000000	16	1	1	7	7	0111	110	56.3
500	1	00000000	16	1	3	6	6	1000	101	62.5
500	1	00000000	16	1	5	5	5	1001	100	68.8
500	1	00000000	16	1	7	4	4	1010	011	75.0
500	1	00000000	16	1	9	3	3	1011	010	81.3
500	1	00000000	16	1	11	2	2	1100	001	87.5
500	1	00000000	16	1	13	1	1	1101	000	93.8
500	2	00000001	8	1	1	3	3	0011	010	62.5
500	2	00000001	8	1	3	2	2	0100	001	75.0
500	2	00000001	8	1	5	1	1	0101	000	87.5
250	2	00000001	16	1	1	7	7	0111	110	56.3
250	2	00000001	16	1	3	6	6	1000	101	62.5
250	2	00000001	16	1	5	5	5	1001	100	68.8
250	2	00000001	16	1	7	4	4	1010	011	75.0
250	2	00000001	16	1	9	3	3	1011	010	81.3
250	2	00000001	16	1	11	2	2	1100	001	87.5
250	2	00000001	16	1	13	1	1	1101	000	93.8
250	4	00000011	8	1	3	2	2	0100	001	75.0
250	4	00000011	8	1	5	1	1	0101	000	87.5
125	4	00000011	16	1	1	7	7	0111	110	56.3
125	4	00000011	16	1	3	6	6	1000	101	62.5
125	4	00000011	16	1	5	5	5	1001	100	68.8
125	4	00000011	16	1	7	4	4	1010	011	75.0
125	4	00000011	16	1	9	3	3	1011	010	81.3
125	4	00000011	16	1	11	2	2	1100	001	87.5
125	4	00000011	16	1	13	1	1	1101	000	93.8
125	8	00000111	8	1	3	2	2	0100	001	75.0
125	8	00000111	8	1	5	1	1	0101	000	87.5
100	4	00000011	20	1	7	6	6	1100	101	70.0
100	4	00000011	20	1	9	5	5	1101	100	75.0
100	5	00000100	16	1	7	4	4	1010	011	75.0
100	5	00000100	16	1	9	3	3	1011	010	81.3
100	8	00000111	10	1	3	3	3	0101	010	70.0
100	8	00000111	10	1	5	2	2	0110	001	80.0
100	10	00001001	8	1	3	2	2	0100	001	75.0
100	10	00001001	8	1	5	1	1	0101	000	87.5
83.3	4	00000011	24	1	7	8	8	1110	111	66.7
83.3	4	00000011	24	1	9	7	7	1111	110	70.8
83.3	6	00000101	16	1	5	5	5	1001	100	68.8

Table 20-20 Typical Examples of Baud Rate Settings ($f_{CANMOD} = 8 \text{ MHz}$) (2/2)

Baud Rate Setting Value (unit: kbps)	Division Ratio of FCNnCM BRPRS	FCNnCM BRPRS Setting Value	Valid Bit-Rate Setting (Unit: TQ)					FCNnCM BTCTL Setting Value		Sampling Point (Unit: %)
			DBT Length	SYNC SEGMENT	PROP SEGMENT	PHASE SEGMENT 1	PHASE SEGMENT 2	FCNnCM BTS1LG [3:0]	FCNnCM BTS2LG [2:0]	
83.3	6	00000101	16	1	7	4	4	1010	011	75.0
83.3	6	00000101	16	1	9	3	3	1011	010	81.3
83.3	6	00000101	16	1	11	2	2	1100	001	87.5
83.3	8	00000111	12	1	5	3	3	0111	010	75.0
83.3	8	00000111	12	1	7	2	2	1000	001	83.3
83.3	12	00001011	8	1	3	2	2	0100	001	75.0
83.3	12	00001011	8	1	5	1	1	0101	000	87.5
33.3	10	00001001	24	1	7	8	8	1110	111	66.7
33.3	10	00001001	24	1	9	7	7	1111	110	70.8
33.3	12	00001011	20	1	7	6	6	1100	101	70.0
33.3	12	00001011	20	1	9	5	5	1101	100	75.0
33.3	15	00001110	16	1	7	4	4	1010	011	75.0
33.3	15	00001110	16	1	9	3	3	1011	010	81.3
33.3	16	00001111	15	1	6	4	4	1001	011	73.3
33.3	16	00001111	15	1	8	3	3	1010	010	80.0
33.3	20	00010011	12	1	5	3	3	0111	010	75.0
33.3	20	00010011	12	1	7	2	2	1000	001	83.3
33.3	24	00010111	10	1	3	3	3	0101	010	70.0
33.3	24	00010111	10	1	5	2	2	0110	001	80.0
33.3	30	00011101	8	1	3	2	2	0100	001	75.0
33.3	30	00011101	8	1	5	1	1	0101	000	87.5

- Caution 1. The values in Table 20-21, Typical Examples of Baud Rate Settings ($f_{CANMOD} = 16 \text{ MHz}$), do not guarantee the operation of the network system. Thoroughly check the effects of set values on the network system, considering oscillation errors and delays of the CAN bus and CAN transceiver.
- Caution 2. Baud rates higher than 500 kbit/s are not allowed when f_{CANMOD} is 8 MHz or less.

Table 20-21 Typical Examples of Baud Rate Settings ($f_{CANMOD} = 16 \text{ MHz}$) (1/2)

Baud Rate Setting Value (unit: kbps)	Division Ratio of FCNnCM BRPRS	FCNnCM BR PRS Setting Value	Valid Bit-Rate Setting (Unit: TQ)					FCNnCM BTCTL Setting Value		Sampling Point (Unit: %)
			DBT Length	SYNC SEGMENT	PROP SEGMENT	PHASE SEGMENT 1	PHASE SEGMENT 2	FCNnCM BTS1LG [3:0]	FCNnCM BTS2LG [2:0]	
1000	1	00000000	16	1	1	7	7	0111	110	56.3
1000	1	00000000	16	1	3	6	6	1000	101	62.5
1000	1	00000000	16	1	5	5	5	1001	100	68.8
1000	1	00000000	16	1	7	4	4	1010	011	75.0
1000	1	00000000	16	1	9	3	3	1011	010	81.3
1000	1	00000000	16	1	11	2	2	1100	001	87.5
1000	1	00000000	16	1	13	1	1	1101	000	93.8
1000	2	00000001	8	1	3	2	2	0100	001	75.0
1000	2	00000001	8	1	5	1	1	0101	000	87.5
500	2	00000001	16	1	1	7	7	0111	110	56.3
500	2	00000001	16	1	3	6	6	1000	101	62.5
500	2	00000001	16	1	5	5	5	1001	100	68.8
500	2	00000001	16	1	7	4	4	1010	011	75.0
500	2	00000001	16	1	9	3	3	1011	010	81.3
500	2	00000001	16	1	11	2	2	1100	001	87.5
500	2	00000001	16	1	13	1	1	1101	000	93.8
500	4	00000011	8	1	3	2	2	0100	001	75.0
500	4	00000011	8	1	5	1	1	0101	000	87.5
250	4	00000011	16	1	3	6	6	1000	101	62.5
250	4	00000011	16	1	5	5	5	1001	100	68.8
250	4	00000011	16	1	7	4	4	1010	011	75.0
250	4	00000011	16	1	9	3	3	1011	010	81.3
250	4	00000011	16	1	11	2	2	1100	001	87.5
250	8	00000111	8	1	3	2	2	0100	001	75.0
250	8	00000111	8	1	5	1	1	0101	000	87.5
125	8	00000111	16	1	3	6	6	1000	101	62.5
125	8	00000111	16	1	7	4	4	1010	011	75.0
125	8	00000111	16	1	9	3	3	1011	010	81.3
125	8	00000111	16	1	11	2	2	1100	001	87.5
125	16	00001111	8	1	3	2	2	0100	001	75.0
125	16	00001111	8	1	5	1	1	0101	000	87.5
100	8	00000111	20	1	9	5	5	1101	100	75.0
100	8	00000111	20	1	11	4	4	1110	011	80.0
100	10	00001001	16	1	7	4	4	1010	011	75.0
100	10	00001001	16	1	9	3	3	1011	010	81.3
100	16	00001111	10	1	3	3	3	0101	010	70.0
100	16	00001111	10	1	5	2	2	0110	001	80.0
100	20	00010011	8	1	3	2	2	0100	001	75.0
83.3	8	00000111	24	1	7	8	8	1110	111	66.7

Table 20-21 Typical Examples of Baud Rate Settings ($f_{CANMOD} = 16 \text{ MHz}$) (2/2)

Baud Rate Setting Value (unit: kbps)	Division Ratio of FCNnCM BRPRS	FCNnCM BR PRS Setting Value	Valid Bit-Rate Setting (Unit: TQ)					FCNnCM BTCTL Setting Value		Sampling Point (Unit: %)
			DBT Length	SYNC SEGMENT	PROP SEGMENT	PHASE SEGMENT 1	PHASE SEGMENT 2	FCNnCM BTS1LG [3:0]	FCNnCM BTS2LG [2:0]	
83.3	8	00001111	24	1	9	7	7	1111	110	70.8
83.3	12	00001011	16	1	7	4	4	1010	011	75.0
83.3	12	00001011	16	1	9	3	3	1011	010	81.3
83.3	12	00001011	16	1	11	2	2	1100	001	87.5
83.3	16	00001111	12	1	5	3	3	0111	010	75.0
83.3	16	00001111	12	1	7	2	2	1000	001	83.3
83.3	24	00010111	8	1	3	2	2	0100	001	75.0
83.3	24	00010111	8	1	5	1	1	0101	000	87.5
33.3	30	00011101	24	1	7	8	8	1110	111	66.7
33.3	30	00011101	24	1	9	7	7	1111	110	70.8
33.3	24	00010111	20	1	9	5	5	1101	100	75.0
33.3	24	00010111	20	1	11	4	4	1110	011	80.0
33.3	30	00011101	16	1	7	4	4	1010	011	75.0
33.3	30	00011101	16	1	9	3	3	1011	010	81.3
33.3	32	00011111	15	1	8	3	3	1010	010	80.0
33.3	32	00011111	15	1	10	2	2	1011	001	86.7
33.3	37	00100100	13	1	6	3	3	1000	010	76.9
33.3	37	00100100	13	1	8	2	2	1001	001	84.6
33.3	40	00100111	12	1	5	3	3	0111	010	75.0
33.3	40	00100111	12	1	7	2	2	1000	001	83.3
33.3	48	00101111	10	1	3	3	3	0101	010	70.0
33.3	48	00101111	10	1	5	2	2	0110	001	80.0
33.3	60	00111011	8	1	3	2	2	0100	001	75.0
33.3	60	00111011	8	1	5	1	1	0101	000	87.5

Caution The values in Table 20-21, Typical Examples of Baud Rate Settings ($f_{CANMOD} = 16 \text{ MHz}$), do not guarantee the operation of the network system. Thoroughly check the effects of set values on the network system, considering oscillation errors and delays of the CAN bus and CAN transceiver.

20.14 Operation of the CAN Controller

This section provides recommended processing procedures required to operate the FCN. Develop a program referring to recommended processing procedures in this section.

20.14.1 Initialization

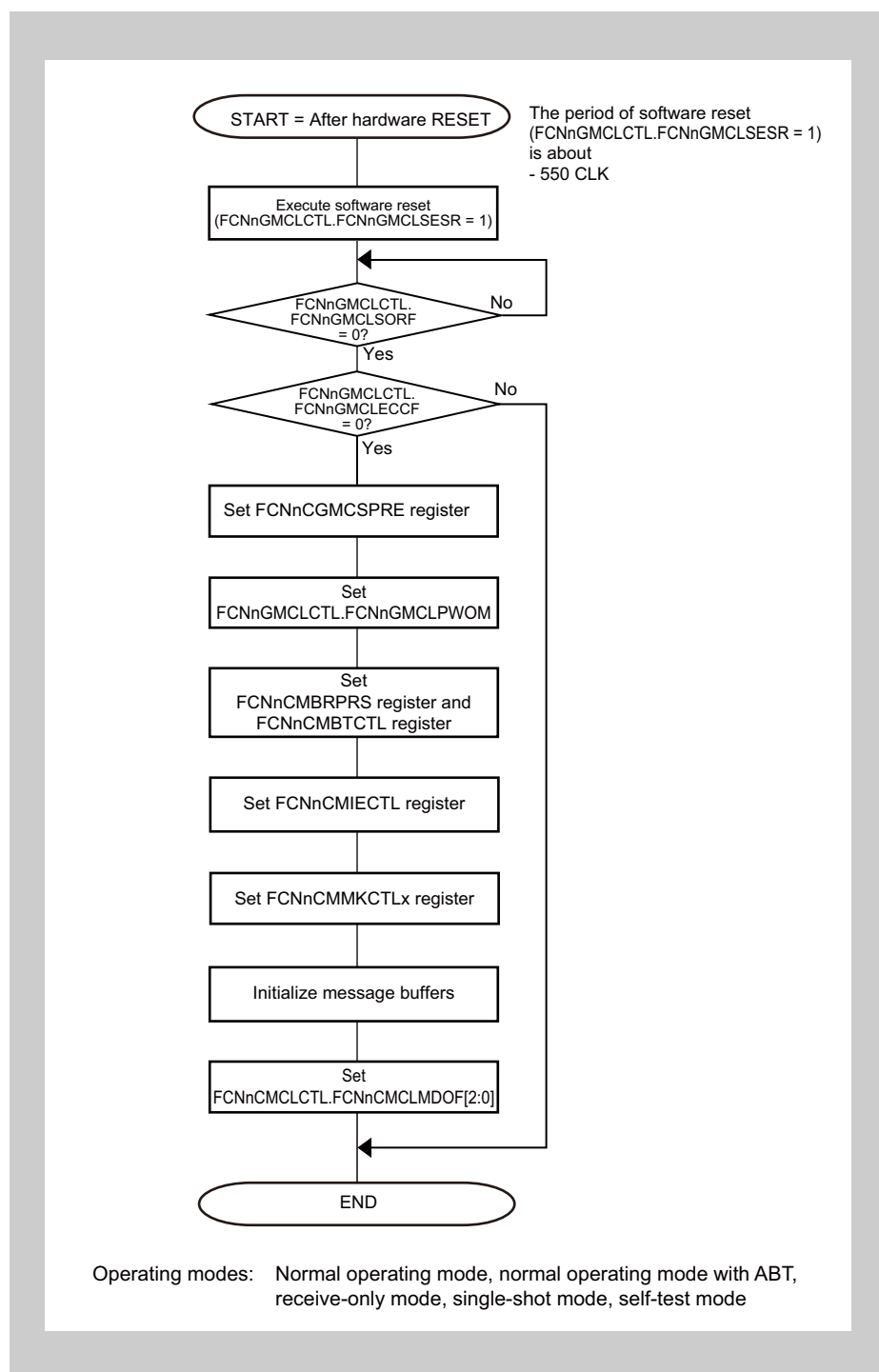

Figure 20-13 Initialization

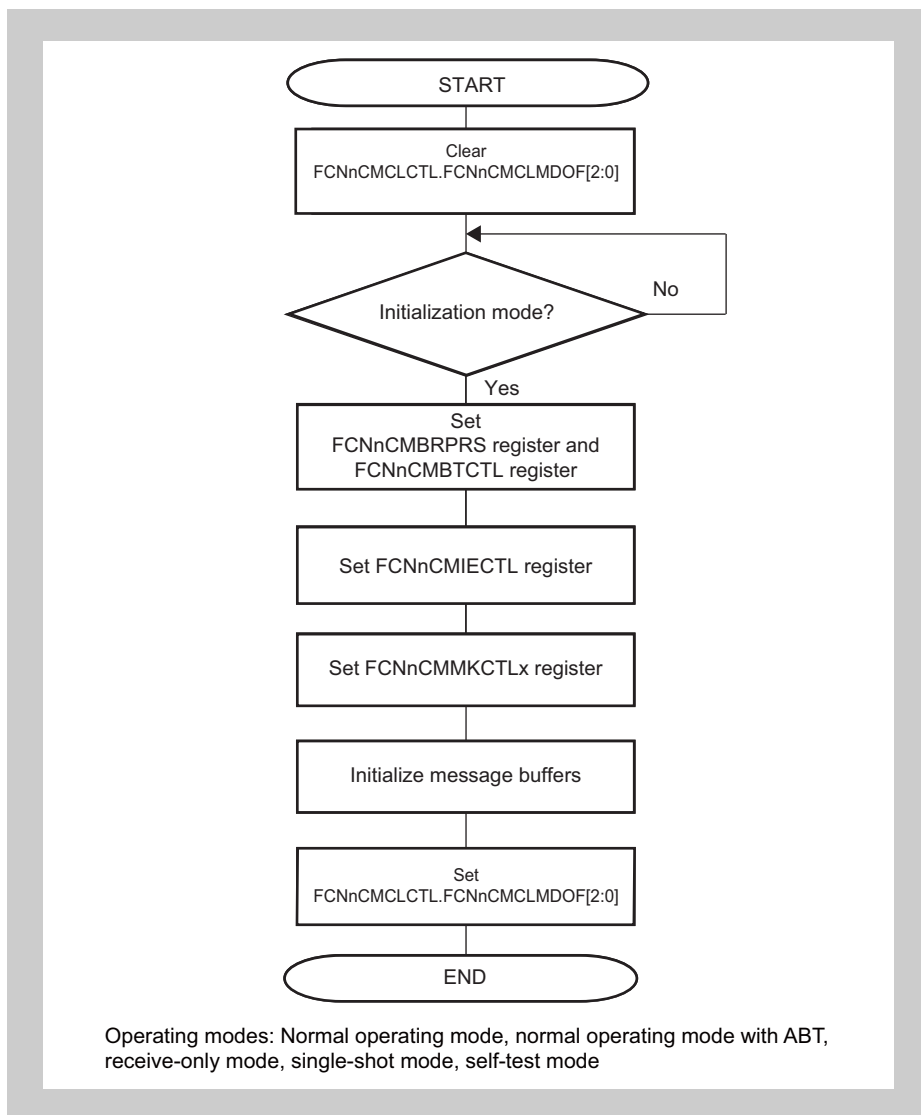

Figure 20-14 Re-initialization without Software Reset Function

- Caution** When clearing the error counter (setting CNnCMCLERCF) during re-initialization, clear it in either of the following states.
- In initialization mode after the FCN module has started (setting FCNnGMCLPWOM from FCNnGMCLPWOM = 0)
 - In initialization mode after all transmit requests have been cleared according to the transmission abort processing in Figure 20-24 in operating mode (In normal operating mode with ABT, clear all transmit requests according to the transmission abort processing in Figure 20-25.)

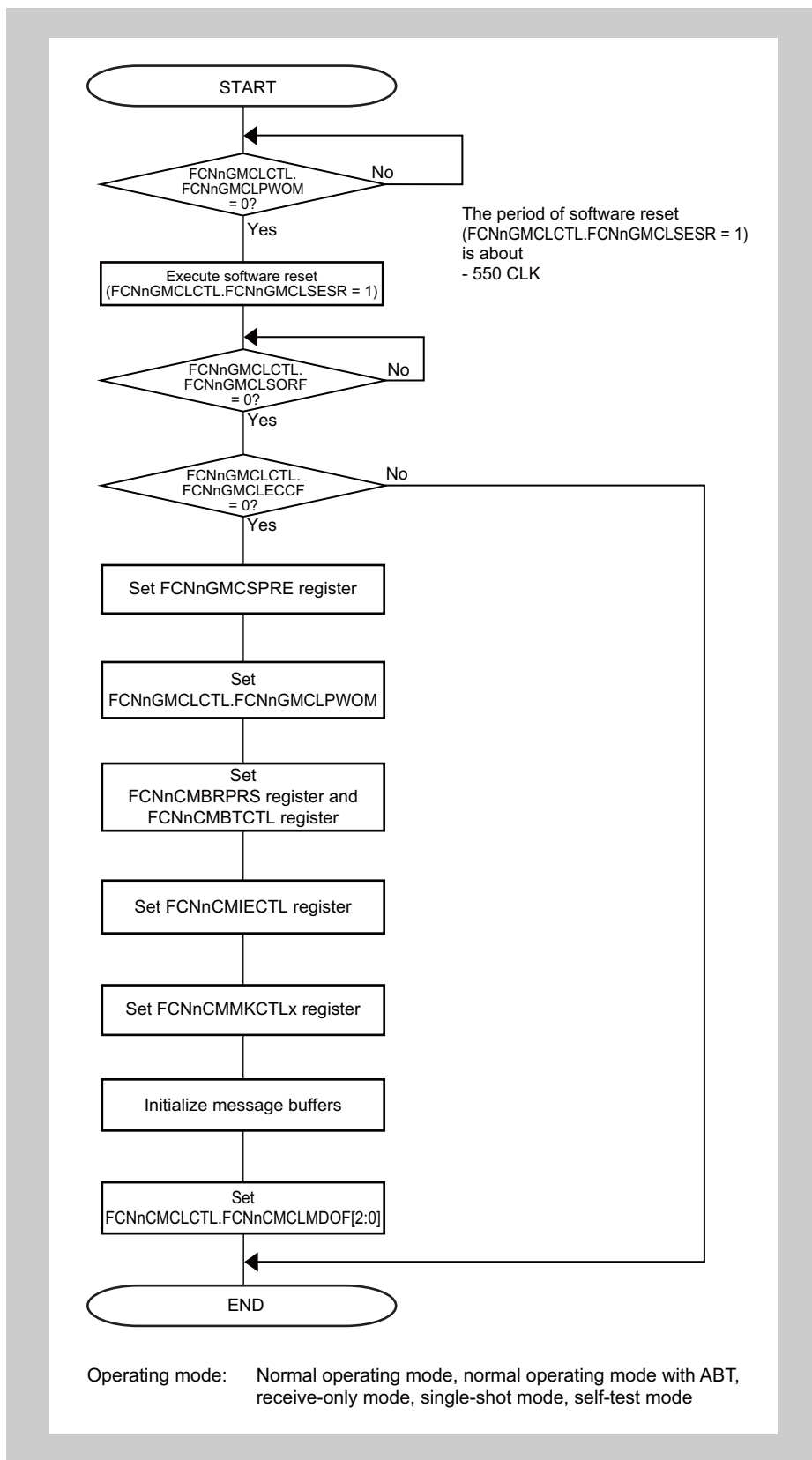

Figure 20-15 Re-initialization with Software Reset Function

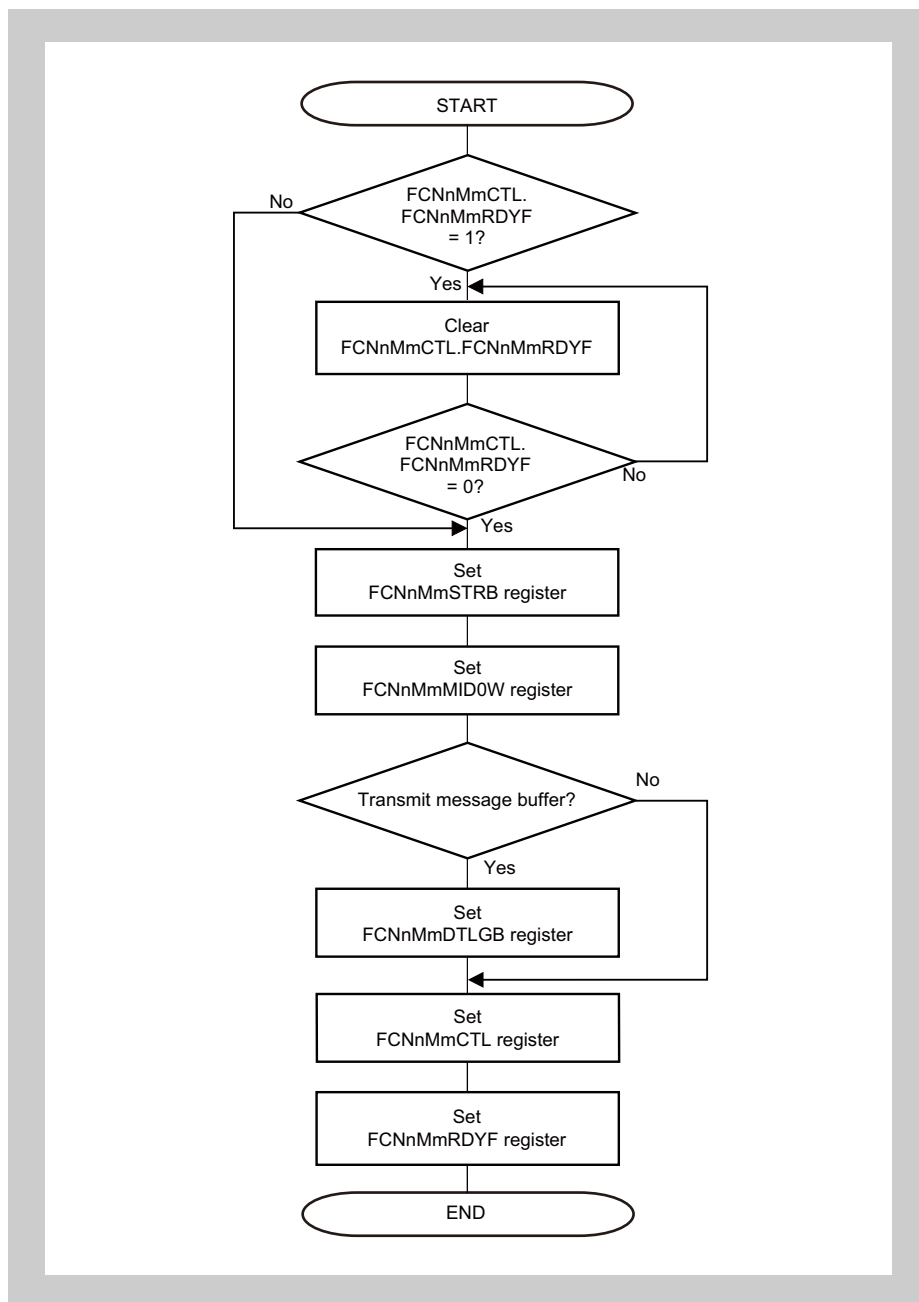

Figure 20-16 Message Buffer Initialization

- Caution 1. Before a message buffer is initialized, FCNnMmCTL.FCNnMmRDYF must be cleared.
- Caution 2. Make the following settings for message buffers not used by the application.
- Clear the FCNnMmRDYF, FCNnMmTRQF, and FCNnMmDTNF bits of the FCNnMmCTL register to 0.
 - Clear FCNnMmSTRB.FCNnMmSSAM to 0.

Figure 20-17, Message Buffer Redefinition during Reception, shows the processing for a receive message buffer (FCNnMmSTRB.FCNnMmSSMT[3:0] = 0001_B to 1000_B).

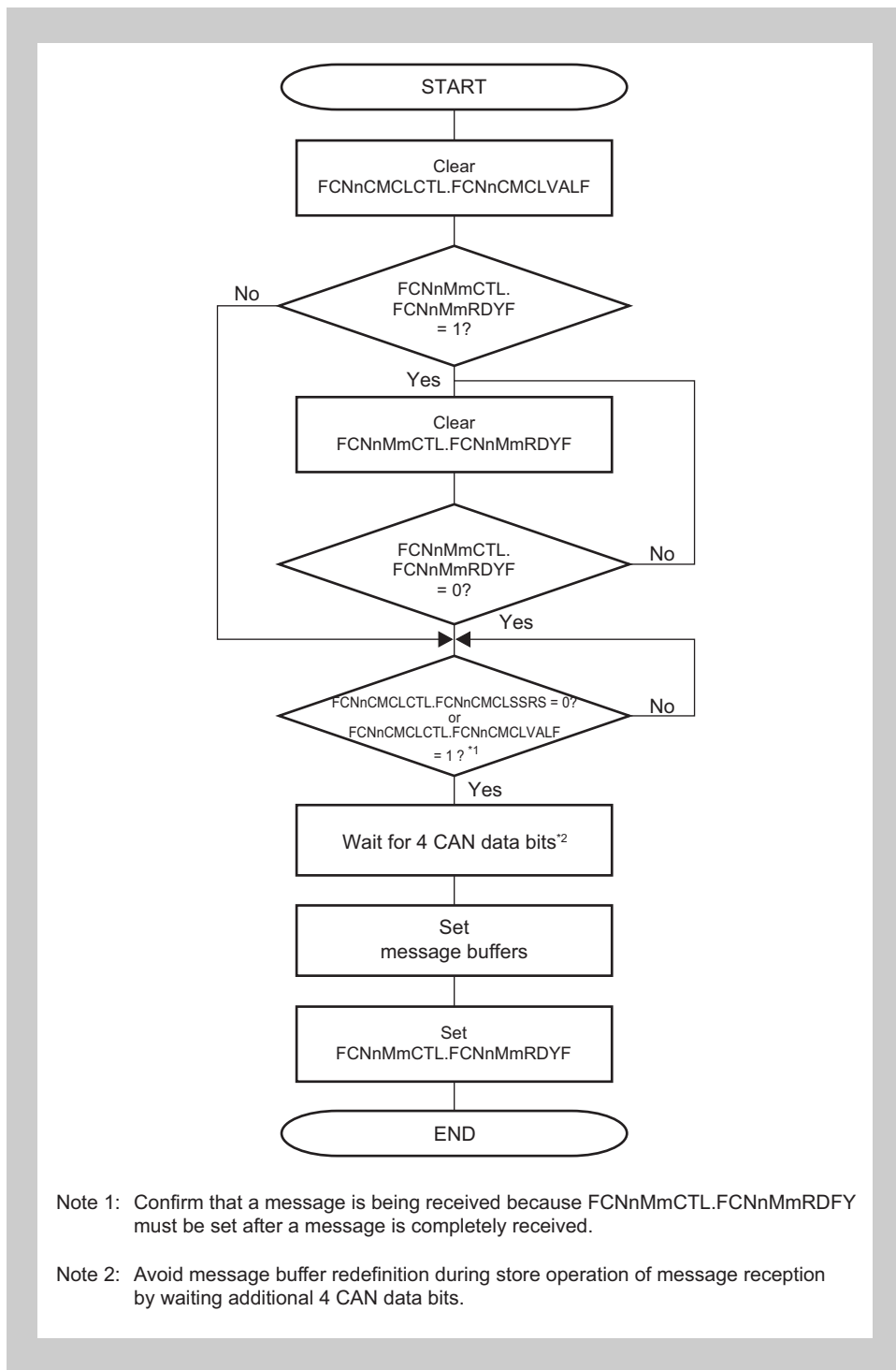

Figure 20-17 Message Buffer Redefinition during Reception

Figure 20-18, Message Buffer Redefinition during Transmission, shows the processing for a transmit message buffer during transmission (FCNnMmSTRB.FCNnMmSSMT[3:0] = 0000_B).

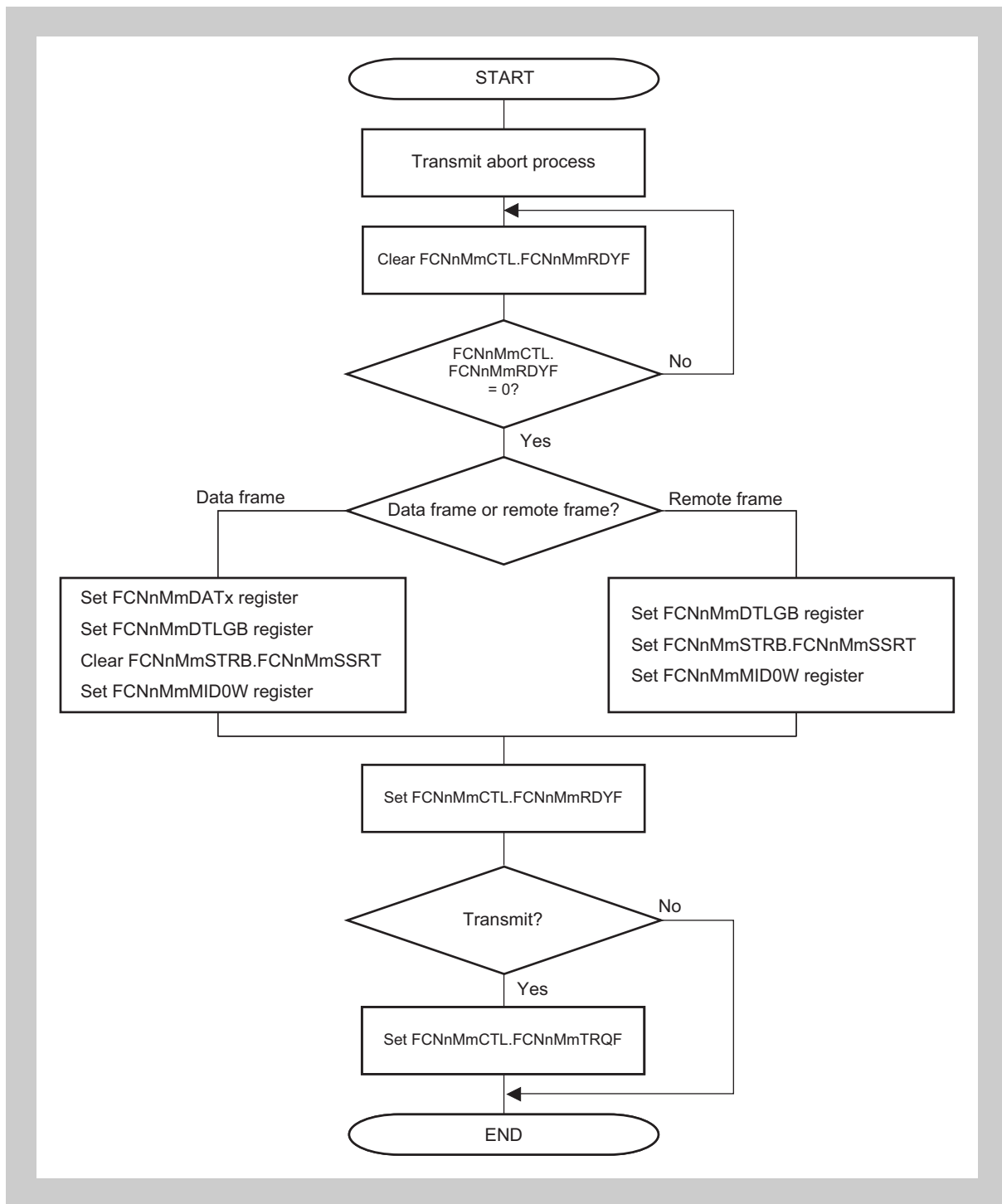

Figure 20-18 Message Buffer Redefinition during Transmission

20.14.2 Message Transmission

Figure 20-19, Message Transmit Processing, shows the processing for a transmit message buffer (FCNnMmSTRB.FCNnMmSSMT[3:0] = 0000_B).

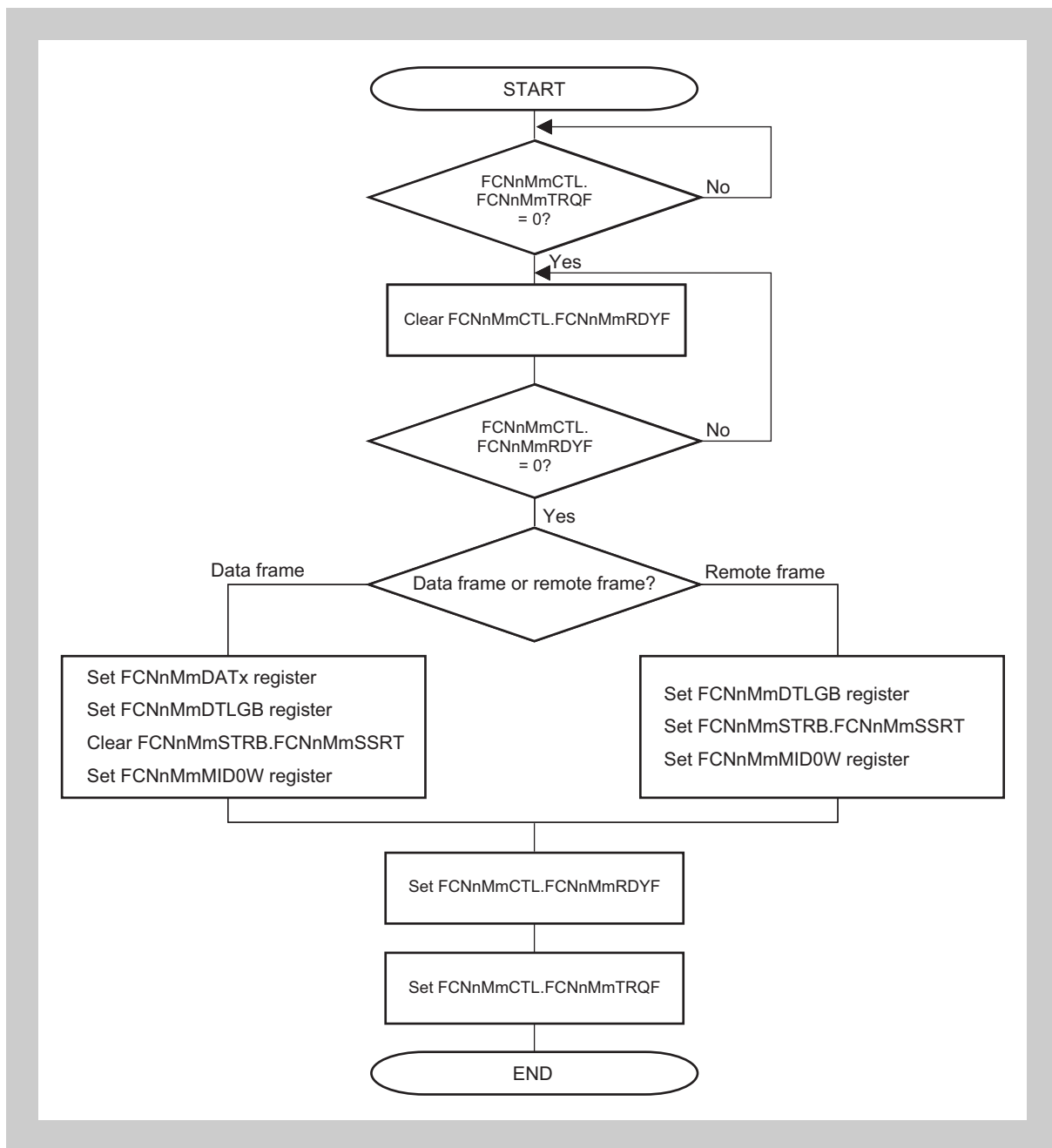

Figure 20-19 Message Transmit Processing

-
- Caution 1. FCNnMmCTL.FCNnMmRDYF must be set before setting FCNnMmCTL.FCNnMmTRQF.
 - Caution 2. Do not set FCNnMmCTL.FCNnMmRDYF and FCNnMmCTL.FCNnMmTRQF at the same time.
-

Figure 20-20, ABT Message Transmit Processing, shows the processing for a transmit message buffer (FCNnMmSTRB.FCNnMmSSMT[3:0] = 0000_B).

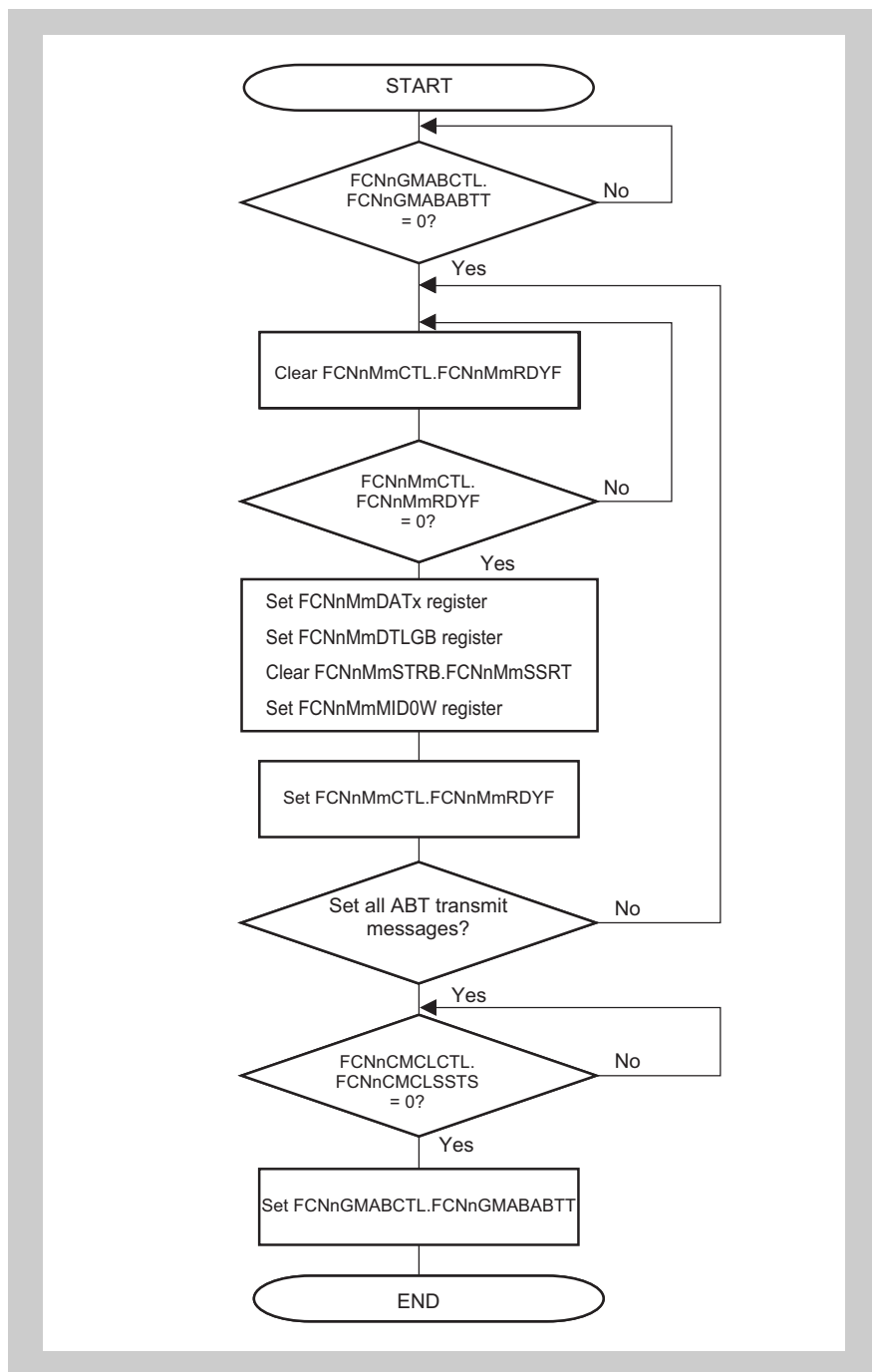

Figure 20-20 ABT Message Transmit Processing

Note This processing (normal operating mode with ABT) can only be applied to message buffers usable with ABT mode. For message buffers other than ABT message buffers, see Figure 20-19, Message Transmit Processing.

Caution FCNnCMCLCTL.FCNnCMCLSSTS must be cleared to 0 before setting FCNnGMABCTL.FCNnGMABABTT to 1. FCNnCMCLCTL.FCNnCMCLSSTS must be checked first and then FCNnGMABCTL.FCNnGMABABTT must be set to 1.

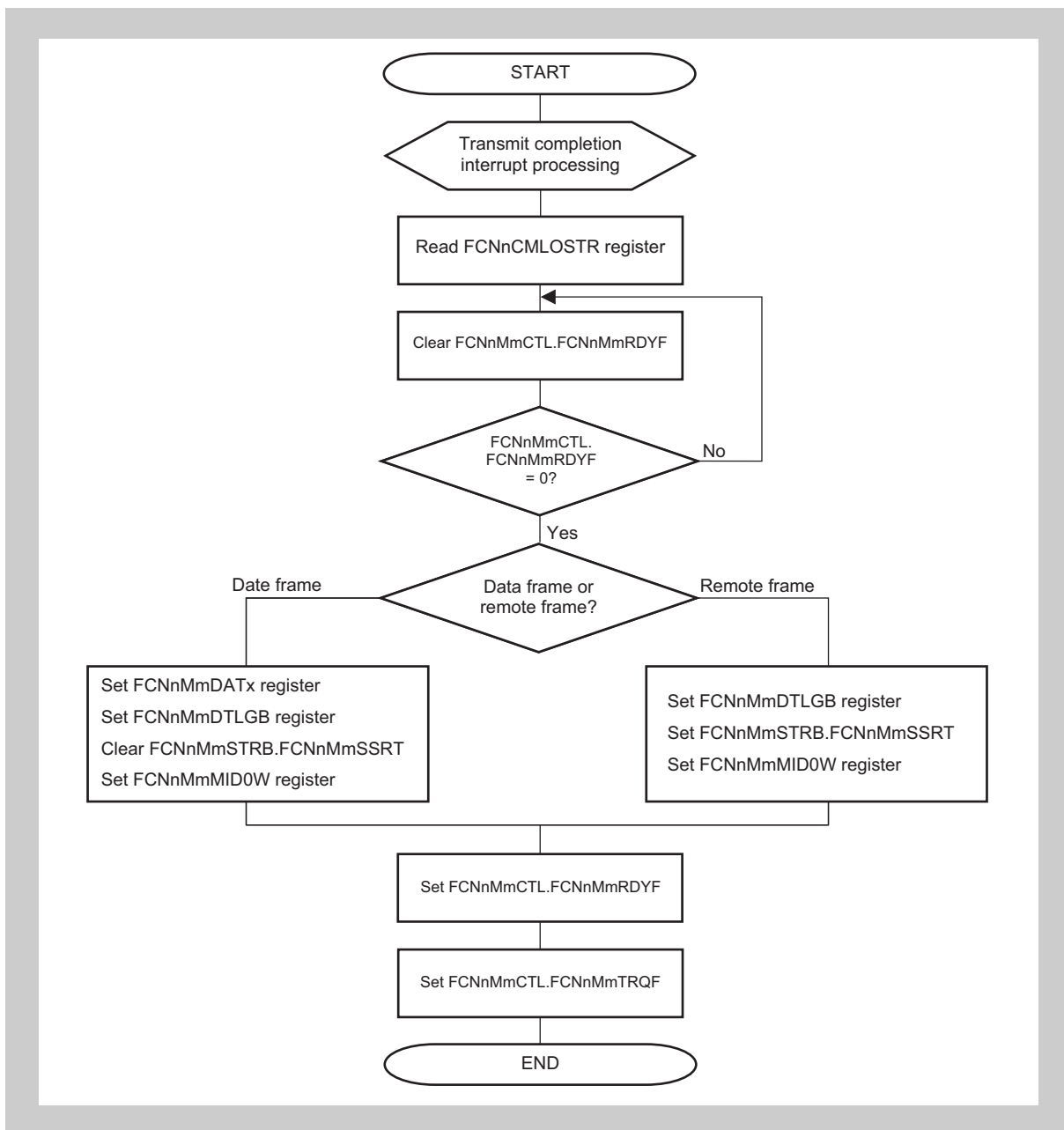

Figure 20-21 Transmission via Interrupt (Using FCNnCMLOSTR Register)

-
- Caution 1. FCNnMmCTL.FCNnMmRDYF must be set before setting FCNnMmCTL.FCNnMmTRQF.
 - Caution 2. Do not set FCNnMmCTL.FCNnMmRDYF and FCNnMmCTL.FCNnMmTRQF at the same time.
-

Note Also check the FCNnGMCLSSMO flag at the beginning and at the end of the interrupt routine, in order to check the access to the message buffers as well as transmit history list registers of the FCN module, in case a pending sleep mode had been executed. If FCNnGMCLSSMO is detected to be cleared at

any check, re-set FCNnGMCLSSMO, discard actions and results of the processing, and then perform processing again.
 It is recommended that all sleep mode requests be cancelled before processing transmission interrupts.

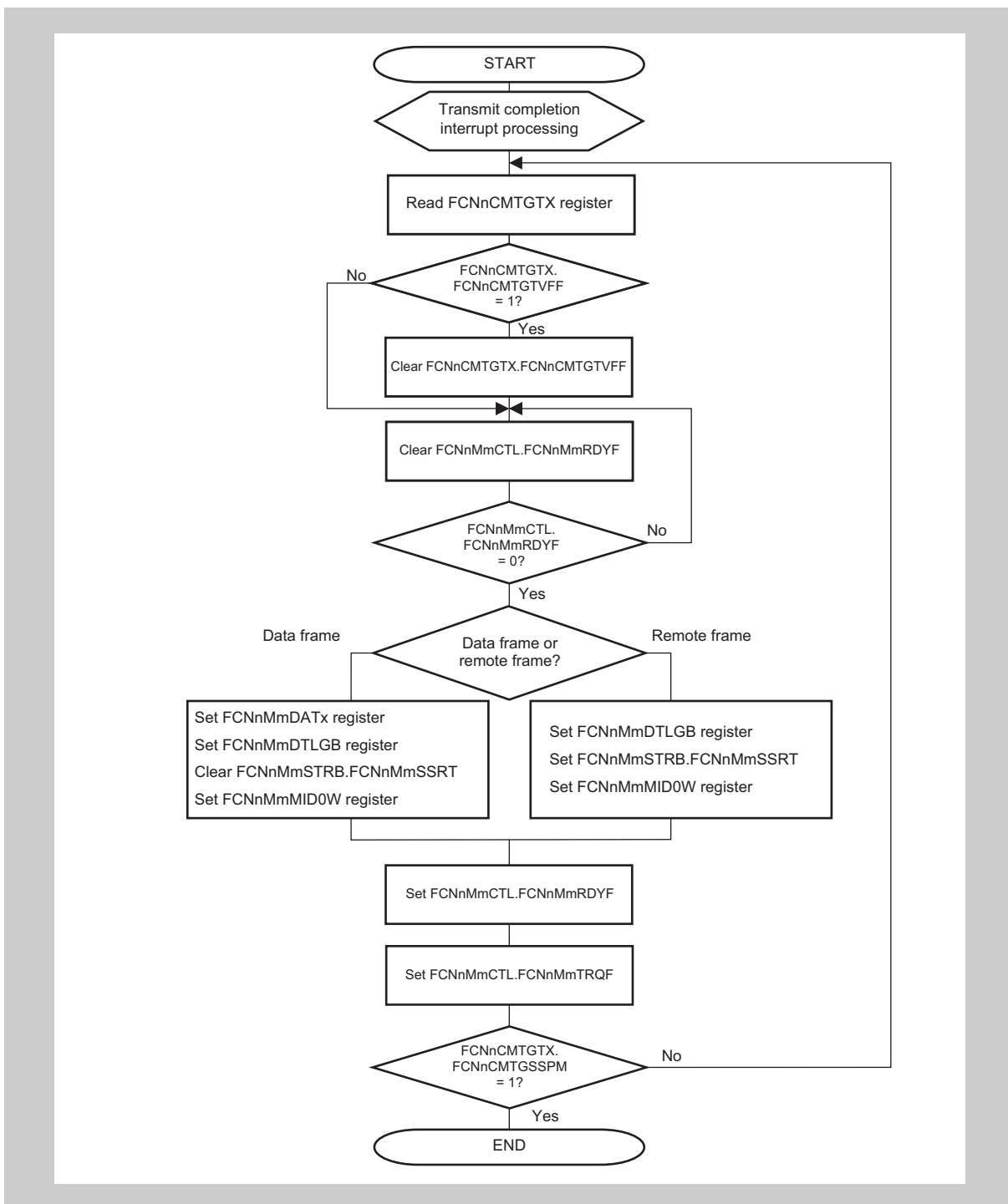

Figure 20-22 Transmission via Interrupt (Using FCNnCMTGTX Register)

- Caution 1. FCNnMmCTL.FCNnMmRDYF must be set before setting FCNnMmCTL.FCNnMmTRQF.
- Caution 2. Do not set FCNnMmCTL.FCNnMmRDYF and FCNnMmCTL.FCNnMmTRQF at the same time.
-

- Note 1. Also check the FCNnGMCLSSMO flag at the beginning and at the end of the interrupt routine, in order to check the access to the message buffers as well as transmit history list registers of the FCN module, in case a pending sleep mode had been executed. If FCNnGMCLSSMO is detected to be cleared at any check, re-set FCNnGMCLSSMO, discard actions and results of the processing, and then perform processing again.
It is recommended that all sleep mode requests be cancelled before processing transmission interrupts.
- Note 2. Once FCNnCMTGTX.FCNnCMTGTVFF is set, the transmit history list is inconsistent. Consider to examine all configured transmit buffers to check completed transmissions.

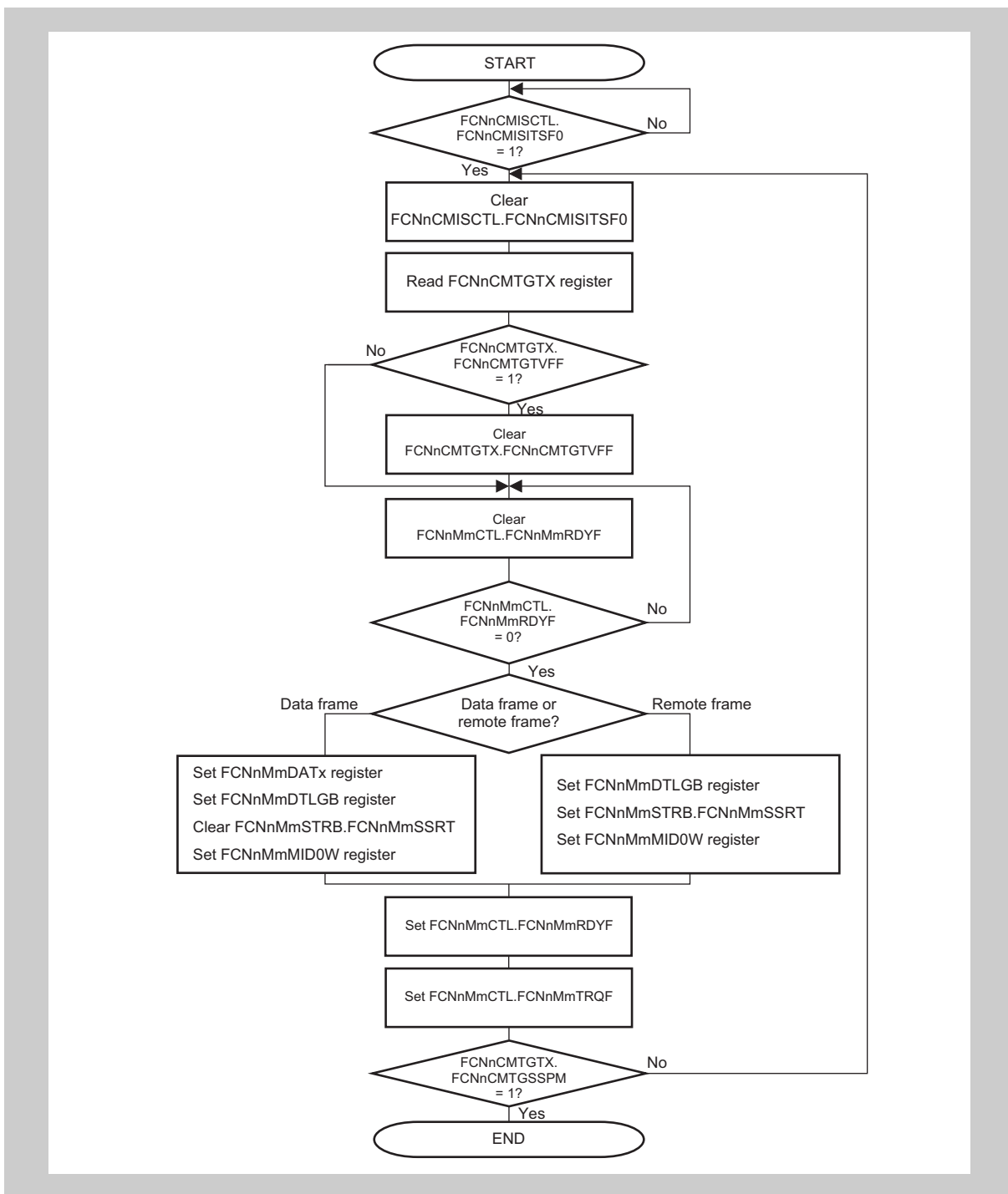

Figure 20-23 Transmission via Software Polling

- Caution 1. FCNnMmCTL.FCNnMmRDYF must be set before setting FCNnMmCTL.FCNnMmTRQF.
- Caution 2. Do not set FCNnMmCTL.FCNnMmRDYF and FCNnMmCTL.FCNnMmTRQF at the same time.

- Note 1. Also check the FCNnGMCLSSMO flag at the beginning and at the end of the polling routine, in order to check the access to the message buffers as well as transmit history list registers of the FCN module, in case a pending sleep mode had been executed. If FCNnGMCLSSMO is detected to be cleared at any check, re-set FCNnGMCLSSMO, discard actions and results of the processing, and then perform processing again. It is recommended that all sleep mode requests be cancelled before processing transmission interrupts.
- Note 2. Once FCNnCMTGTX.FCNnCMTGTVFF is set, the transmit history list is inconsistent. Consider to examine all configured transmit buffers to check completed transmissions.

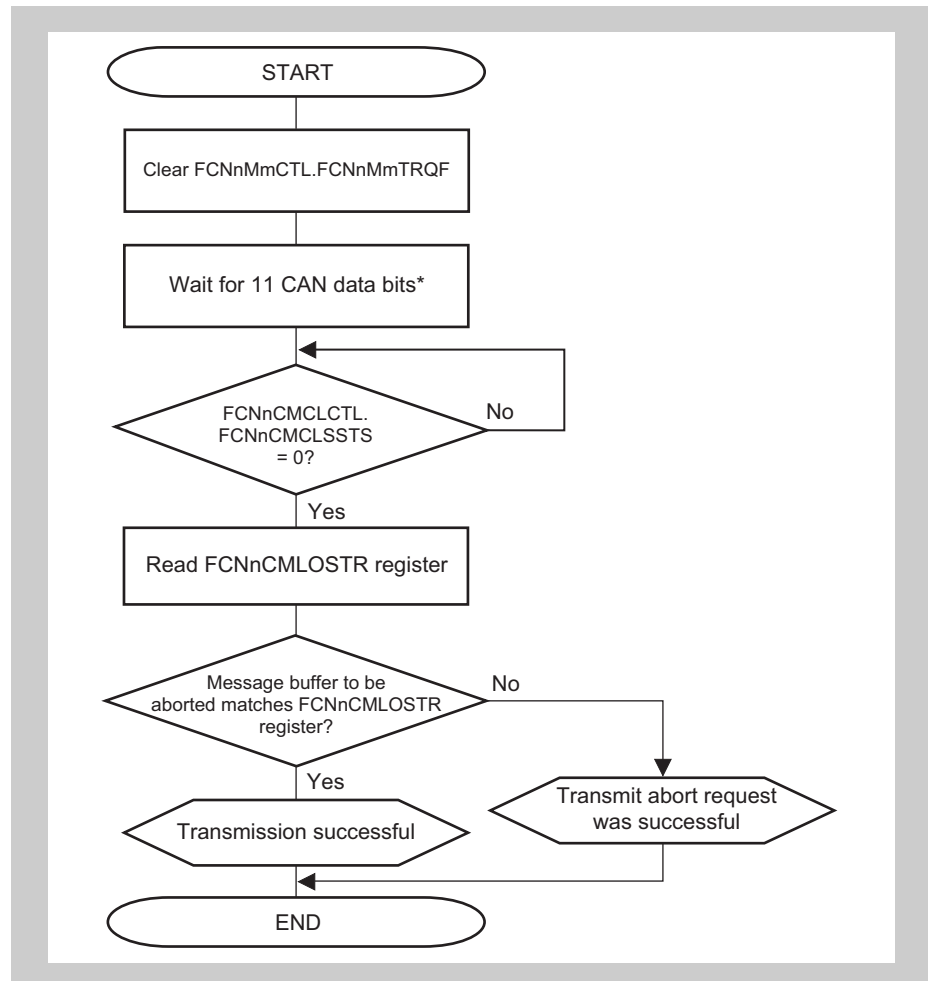

Figure 20-24 Transmission Abort Processing (Except Normal Operating Mode with ABT)

Note * A transmission request to the protocol layer may have been acknowledged during a period of 11 bits (3-bit next inter-frame space + 8-bit transmission abort processing). Therefore, transmission may not be aborted and started even if FCNnMmCTL.FCNnMmTRQF is cleared.

- Caution 1. To request for aborting transmission, clear FCNnMmCTL.FCNnMmTRQF, but not FCNnMmCTL.FCNnMmRDYF.
- Caution 2. Before making a sleep mode transition request, confirm that no transmission request that uses this processing is remaining.
- Caution 3. FCNnCMCLCTL.FCNnCMCLSSTS can be periodically checked by a user application or can be checked after the transmit completion interrupt.
- Caution 4. Do not execute any new transmission request including transmission in other message buffers while transmission abort processing is in progress.

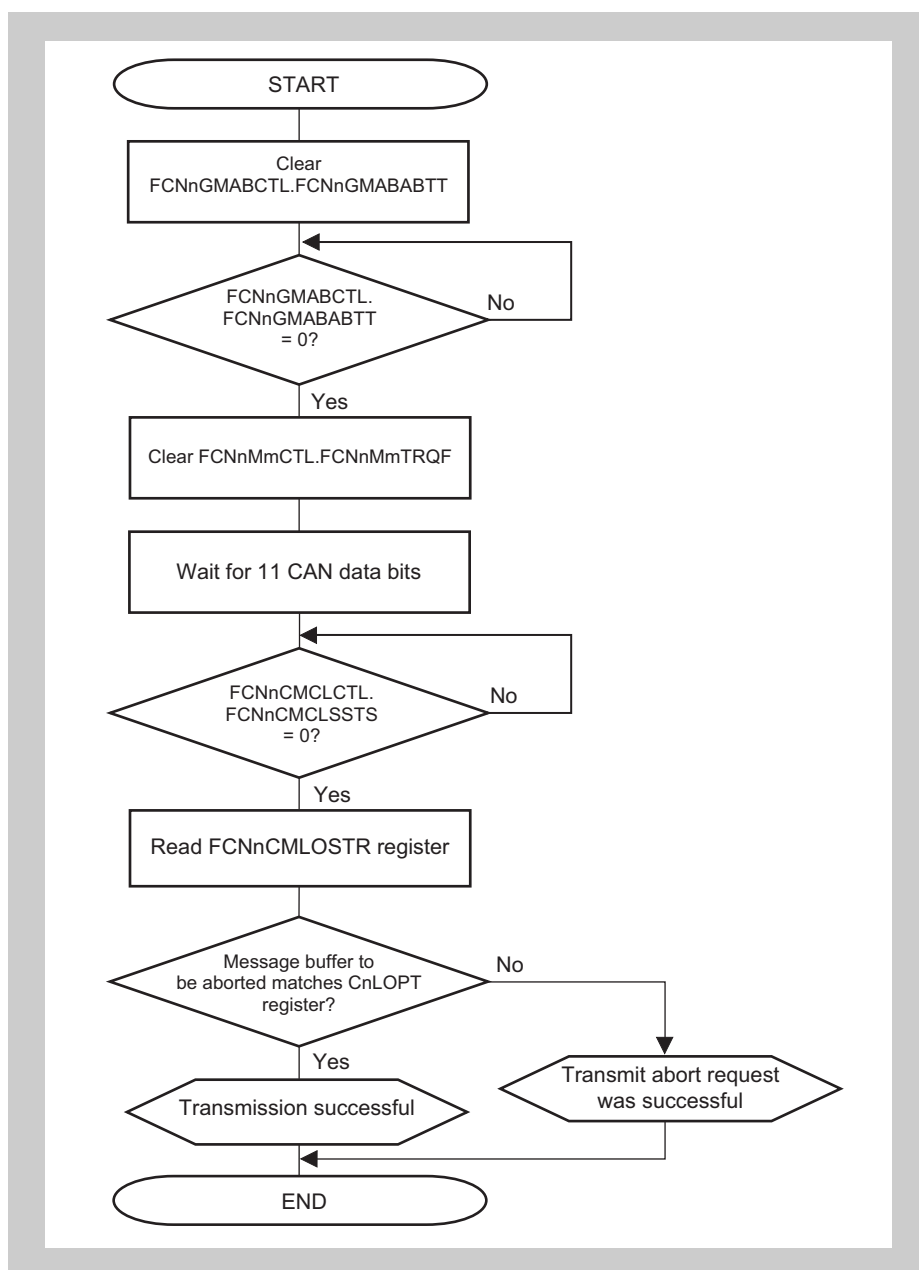

Figure 20-25 Transmission Abort Processing other than the ABT transmission (Normal Operating Mode with ABT)

- Caution 1. To request for aborting transmission, clear FCNnMmCTL.FCNnMmTRQF, but not FCNnMmCTL.FCNnMmRDYF.
- Caution 2. Before making a sleep mode transition request, confirm that no transmission request that uses this processing is remaining.
- Caution 3. FCNnCMCLCTL.FCNnCMCLSSTS can be periodically checked by a user application or can be checked after the transmit completion interrupt.
- Caution 4. Do not execute any new transmission request including transmission in other message buffers while transmission abort processing is in progress.

Note Since the transmission request to the protocol layer has already been acknowledged, transmission may be started during a period of 11 bits (3-bit next inter-frame space plus 8-bit transmission abort processing) even if the FCNnMmCTL.FCNnMmTRQF bit is cleared.

Figure 20-26, ABT Transmission Request Abort Processing (Normal Operating Mode with ABT) (1), shows the processing not to skip resumption of transmitting a message that was stopped when transmission of an ABT message buffer was aborted.

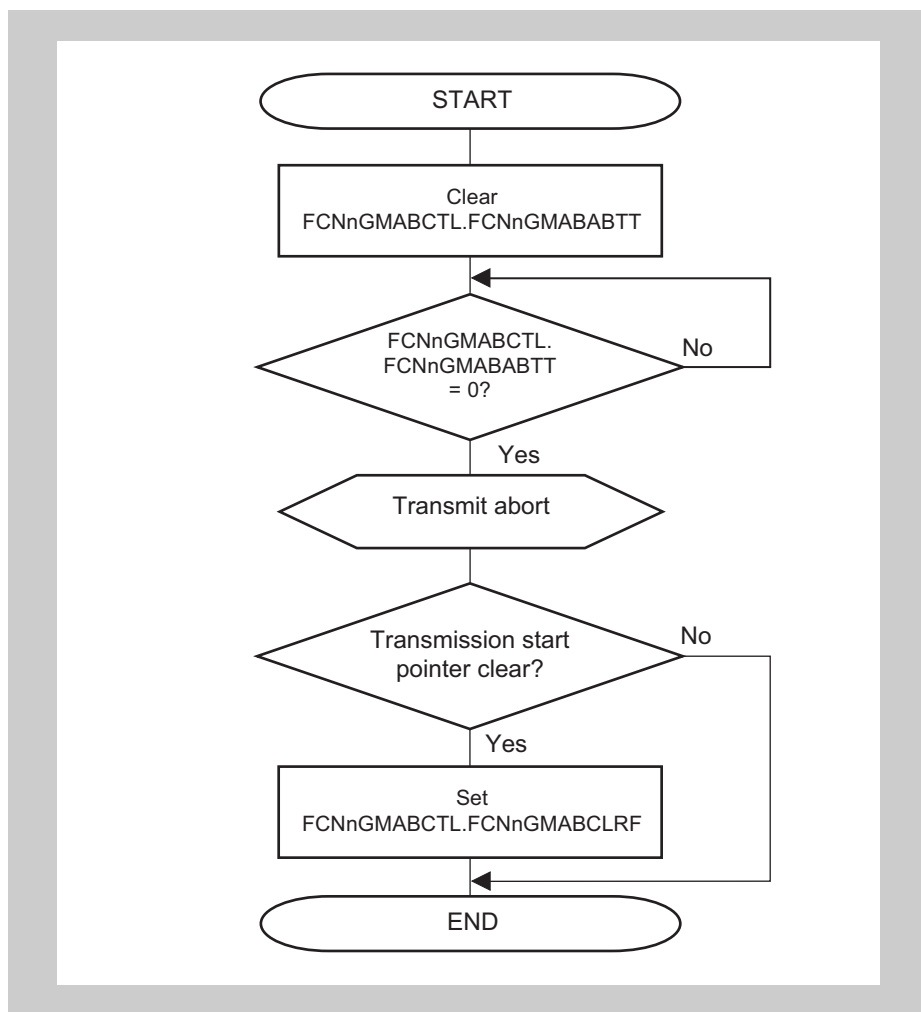

Figure 20-26 ABT Transmission Request Abort Processing (Normal Operating Mode with ABT) (1)

- Caution 1. Do not set any transmission request while ABT transmission abort processing is in progress.
- Caution 2. Make a FCN sleep mode/FCN stop mode transition request after FCNnGMABCTL.FCNnGMABABTT is cleared (after ABT mode is aborted) following the procedure shown in Figure 20-26, ABT Transmission Request Abort Processing (Normal Operating Mode with ABT) (1), or Figure 20-27, ABT Transmission Request Abort Processing (Normal Operating Mode with ABT) (2) with Transmission Abort Interrupt Flag. When clearing a transmission request in an area other than the ABT area, follow the procedure shown in Figure 20-24, Transmission Abort Processing (Except Normal Operating Mode with ABT).
-

Figure 20-27 ABT Transmission Request Abort Processing (Normal Operating Mode with ABT) (2), shows the processing to skip resumption of transmitting a message that was stopped when transmission of an ABT message buffer was aborted.

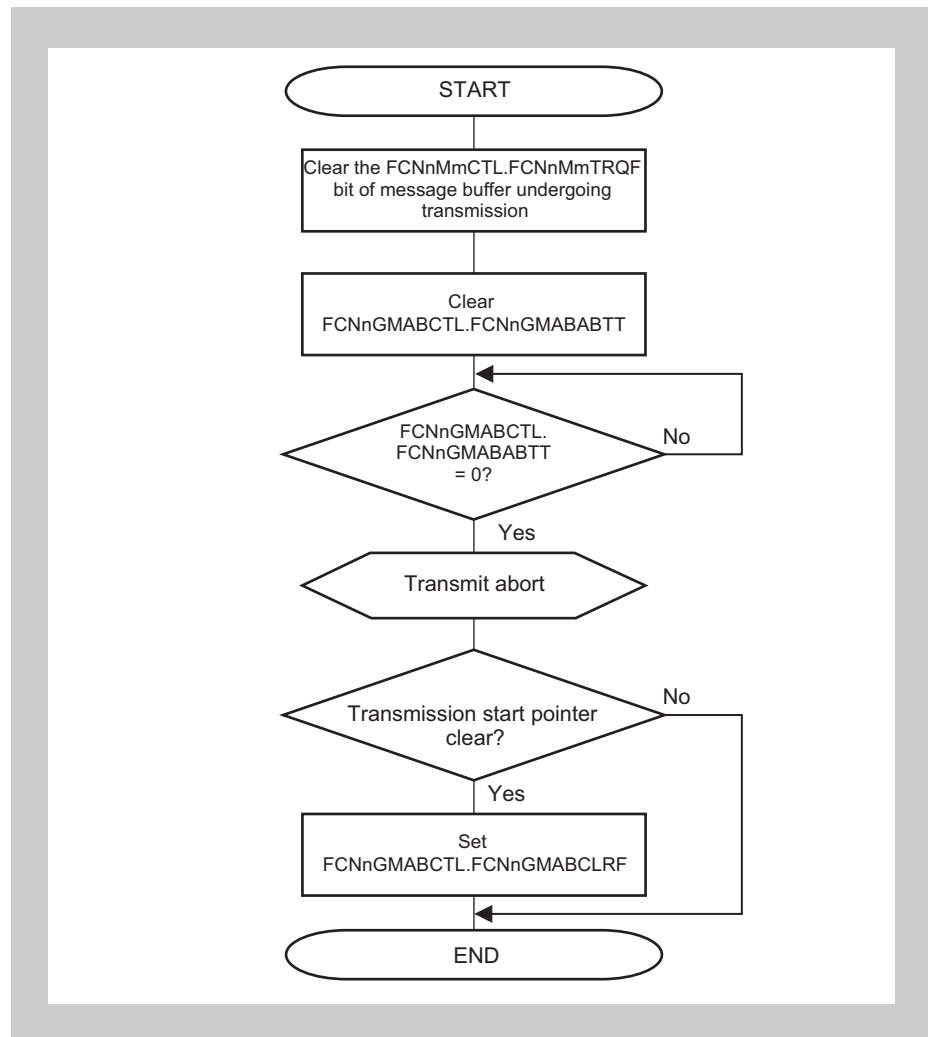

Figure 20-27 ABT Transmission Request Abort Processing (Normal Operating Mode with ABT) (2)

- Caution 1. Do not set any transmission request while ABT transmission abort processing is in progress.
- Caution 2. Make a FCN sleep mode/FCN stop mode transition request after FCnGMABCTL.FCnGMABABTT is cleared (after ABT mode is aborted) following the procedure shown in Figure 20-26, ABT Transmission Request Abort Processing (Normal Operating Mode with ABT) (1), or Figure 20-27, ABT Transmission Request Abort Processing (Normal Operating Mode with ABT) (2). When clearing a transmission request in an area other than the ABT area, follow the procedure shown in Figure 20-24, Transmission Abort Processing (Except Normal Operating Mode with ABT)).

Figure20-28 ABT Transmission Request Abort Processing with Transmission Completion Flag (Normal Operating Mode with ABT), shows the processing in ABT mode using the transmission abort function (transmission completion flag). The step “Transmission abort success” indicates that the transmission was successfully aborted, which was checked by using the FCNnMmTCPF flag in the ABT message buffer.

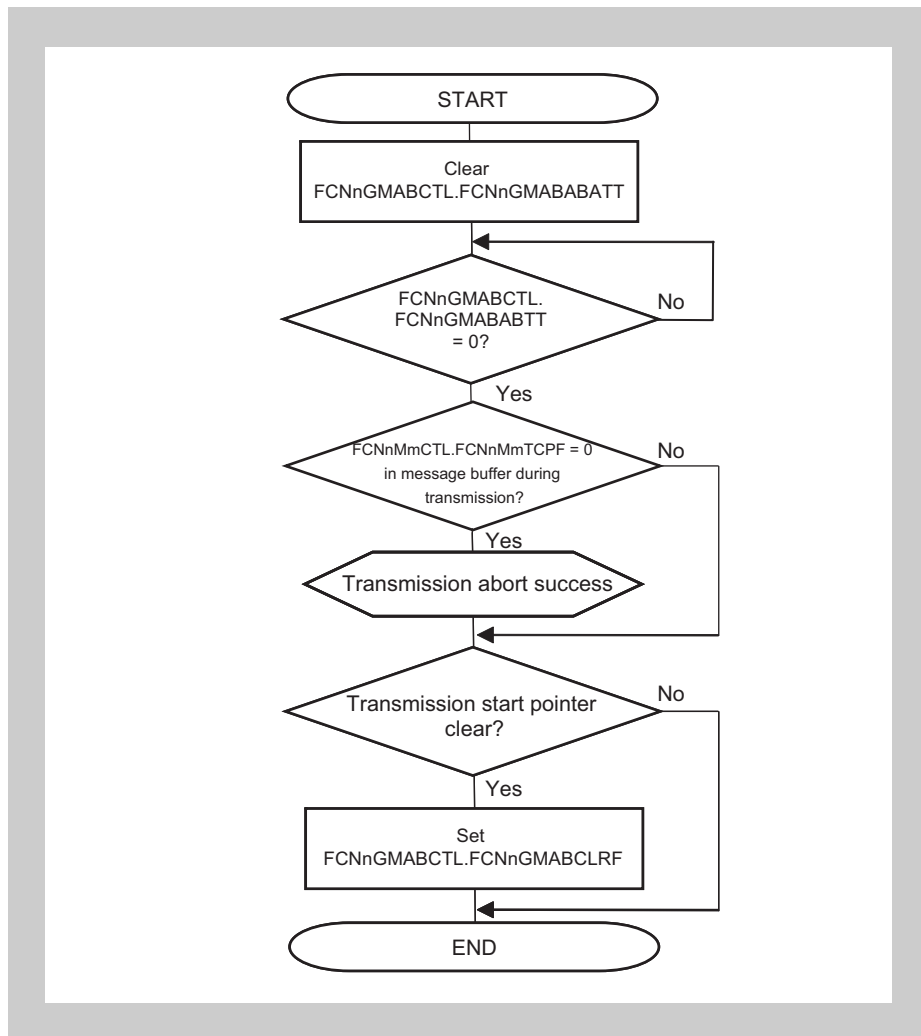

Figure 20-28 ABT Transmission Request Abort Processing with Transmission Completion Flag (Normal Operating Mode with ABT)

- Caution 1. Do not set any transmission request while ABT transmission abort processing is in progress.
- Caution 2. Make a FCN sleep mode/FCN stop mode transition request after FCNnGMABCTL.FCNnGMABABTT is cleared (after ABT mode is aborted) following the procedure shown in Figure 20-26, ABT Transmission Request Abort Processing (Normal Operating Mode with ABT) (1), or Figure 20-27, ABT Transmission Request Abort Processing (Normal Operating Mode with ABT) (2). When clearing a transmission request in an area other than the ABT area, follow the procedure shown in Figure 20-24, Transmission Abort Processing (Except Normal Operating Mode with ABT).
-

Note There is the case that all ABT is transmitted completely even if transmission abort interrupt is generated. Then, it is possible to know which message is finished transmission.

Figure 20-29, Transmission Abort Processing with Transmission Abort Interrupt and Transmission Completion Flag and Transmission Completion Flag, shows the processing using the transmission abort function (transmission completion flag).

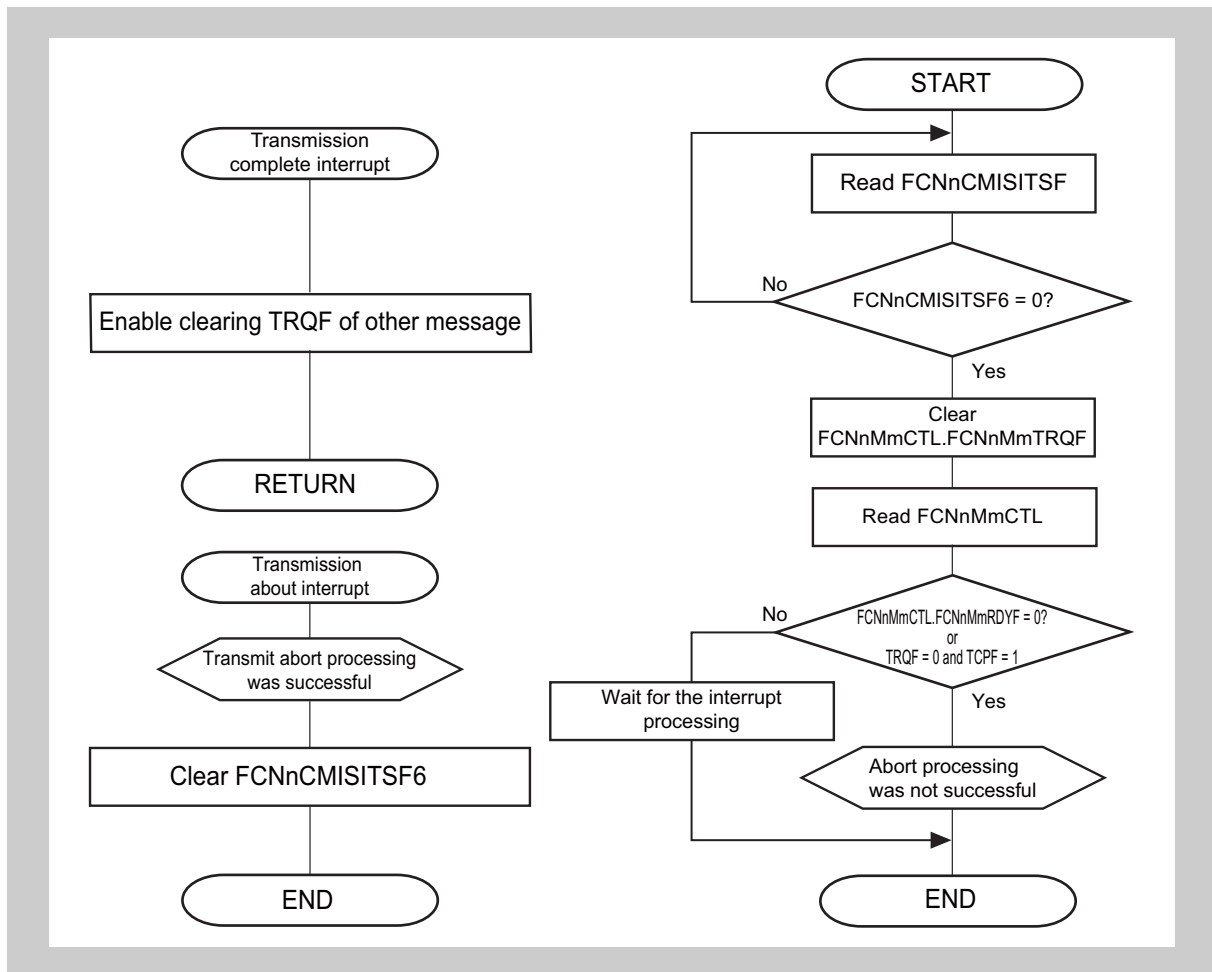

Figure 20-29 Transmission Abort Processing with Transmission Abort Interrupt and Transmission Completion Flag

Note Decision of $FCNnMmRDYF = 0$ is based on that $FCNnMmRDYF$ is cleared during transmission completion processing triggered by an interrupt.

- Caution 1. Perform transmission abort processing by clearing $FCNnMmTRQF$, not by clearing $FCNnMmRDYF$.
- Caution 2. Before making a sleep mode transition request, confirm that there is no transmission request left using this flowchart.
- Caution 3. Avoid the target message from being updated (setting $FCNnMmRDYF$ and $FCNnMmTRQF$) while transmission abort processing is in progress due to the transmission completion processing.
- Caution 4. Do not clear $FCNnMmTRQF$ of other message buffers while transmission abort processing is in progress.
- Caution 5. When setting an ID with lower priority than the previous ID after transmission abort processing, clear $FCNnMmTRQF$ and then make a transmission request with a delay of at least one-frame time period.
- Caution 6. Be sure to read $FCNnMmTRQF$ and $FCNnMmTCPF$ at the same time.

Figure 20-30, Transmission Abort Processing with Transmission Completion Flag, shows the processing using the transmission abort function (transmission completion flag FCNnMmTCPF).

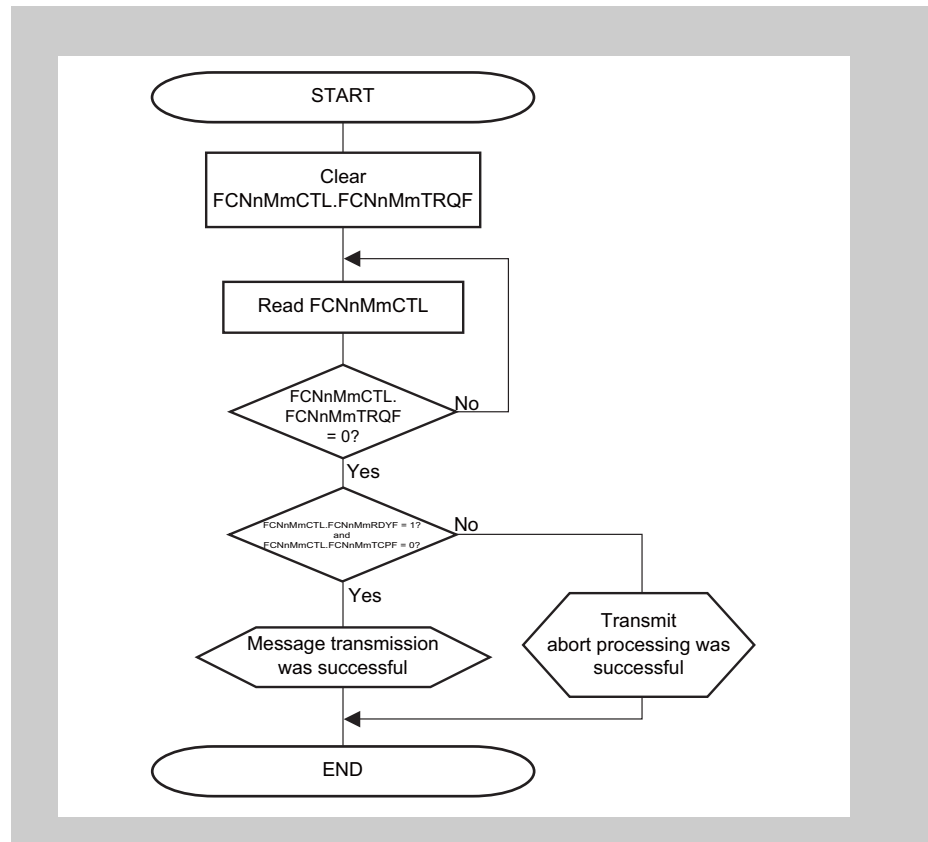

Figure 20-30 Transmission Abort Processing with Transmission Completion Flag

Note Decision of FCNnMmRDYF=1 is based on that FCNnMmRDYF is cleared during transmission completion processing triggered by an interrupt.

-
- Caution 1. Perform transmission abort processing by clearing FCNnMmTRQF, not by clearing FCNnMmRDYF.
 - Caution 2. Before making a sleep mode transition request, confirm that there is no transmission request left using this flowchart.
 - Caution 3. Avoid the target message from being updated (setting FCNnMmRDYF and FCNnMmTRQF) while transmission abort processing is in progress due to the transmission completion processing.
 - Caution 4. When setting an ID with lower priority than the previous ID after transmission abort processing, clear FCNnMmTRQF and then make a transmission request with a delay of at least one-frame time period.
 - Caution 5. Be sure to read FCNnMmTRQF and FCNnMmTCPF at the same time.
-

20.14.3 Message Reception

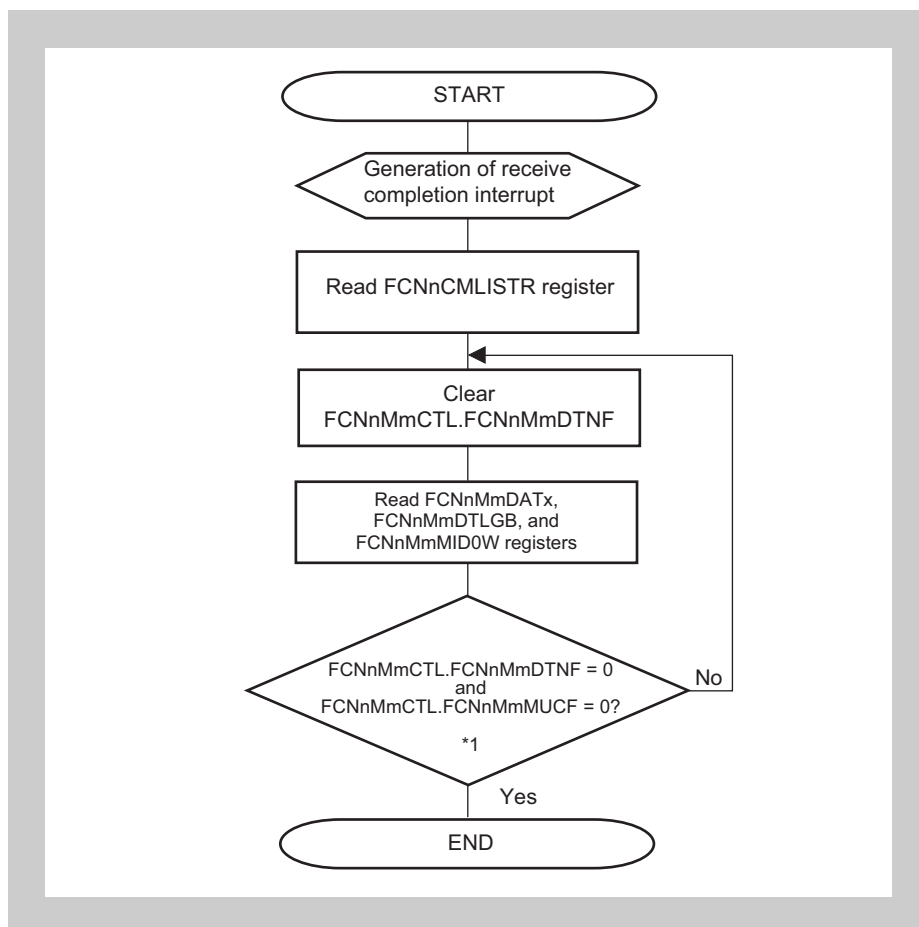

Figure 20-31 Reception via Interrupt (Using FCNnCMLISTR Register)

- Note 1. Check FCNnMmCTL.FCNnMmMUCF and FCNnMmCTL.FCNnMmDTNF bits in one read access.
- Note 2. Also check the FCNnGMCLSSMO flag at the beginning and at the end of the interrupt routine, in order to check the access to the message buffers as well as receive history list registers of the FCN module, in case a pending sleep mode had been executed. If FCNnGMCLSSMO is detected to be cleared at any check, re-set FCNnGMCLSSMO, discard actions and results of the processing, and then perform processing again. It is recommended that all sleep mode requests be cancelled before processing reception interrupts.

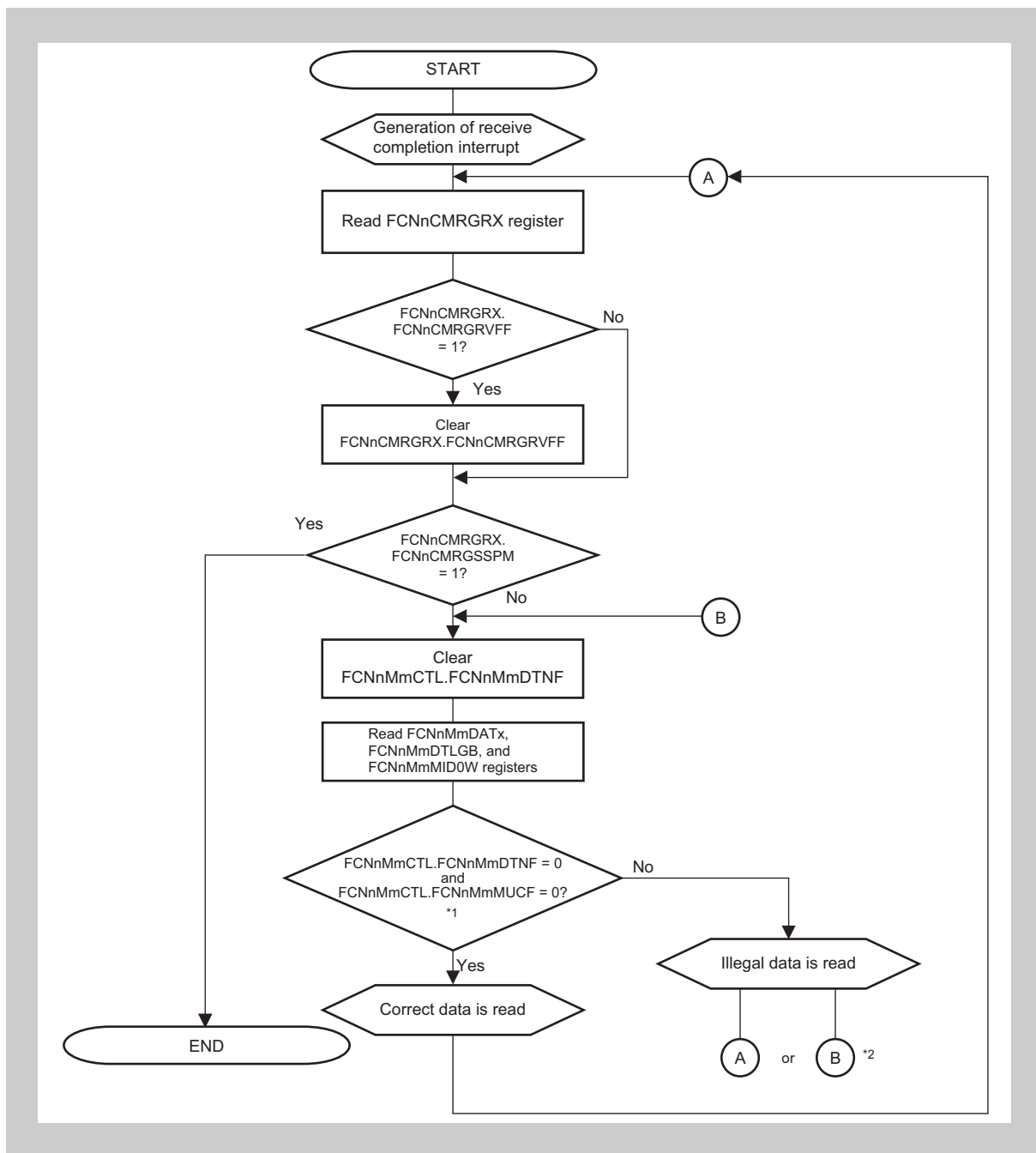

Figure 20-32 Reception via Interrupt (Using FCNnCMRGRX Register)

- Note 1. Check FCNnMmCTL.FCNnMmMUCF and FCNnMmCTL.FCNnMmDTNF bits in one read access.
- Note 2. Depending of the processing target of the application, two ways are possible:
- Way A: The message is not processed within this pass, but with the next pass, depending on the latest timing at which the message is processed with the next reception interrupt. Other messages are processed earlier.
 - Way B: The message is processed within this pass, and the loop enters the waiting state with this message. Other messages are processed later.
- Note 3. Also check the FCNnGMCLSSMO flag at the beginning and at the end of the interrupt routine, in order to check the access to the message buffers as well as receive history list registers of the FCN module, in case a pending sleep mode had been executed. If FCNnGMCLSSMO is detected to be cleared at any check, re-set FCNnGMCLSSMO, discard actions and results of the processing, and then perform processing again.
It is recommended that all sleep mode requests be cancelled before processing reception interrupts.
- Note 4. Once FCNnCMRGRX.FCNnCMRGRVFF is set, the receive history list is inconsistent. Consider to examine all configured receive buffers to check reception.
- Note 5. Figure 20-33, Reception via Interrupt (Using FCNnCMRGRX Register), Alternative Way, Alternative Way, is available as an alternative of Figure 20-32, Reception via Interrupt (Using FCNnCMRGRX Register).

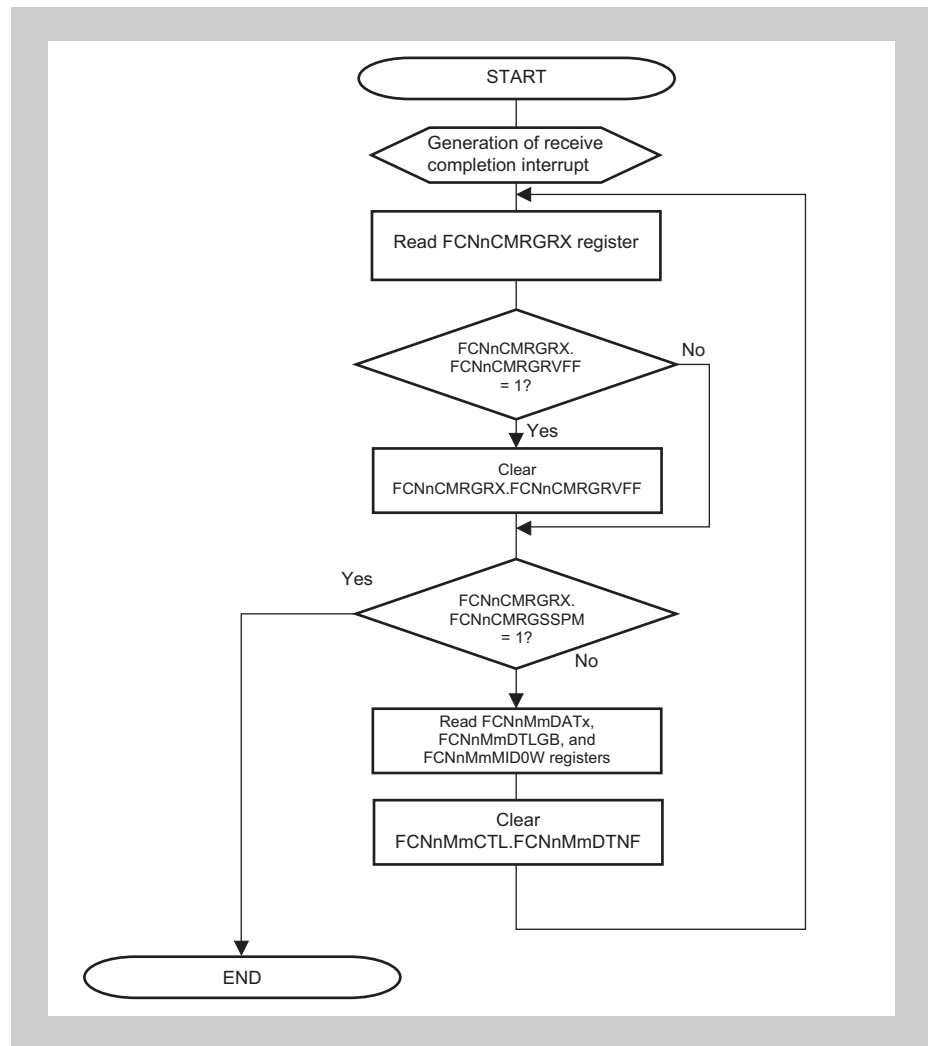

Figure 20-33 Reception via Interrupt (Using FCNnCMRGRX Register), Alternative Way

- Note 1. Also check the FCNnGMCLSSMO flag at the beginning and at the end of the interrupt routine, in order to check the access to the message buffers as well as receive history list registers of the FCN module, in case a pending sleep mode had been executed. If FCNnGMCLSSMO is detected to be cleared at any check, re-set FCNnGMCLSSMO, discard actions and results of the processing, and then perform processing again. It is recommended that all sleep mode requests be cancelled before processing reception interrupts.
- Note 2. Once FCNnCMRGRX.FCNnCMRGRVFF is set, the receive history list is inconsistent. Consider to examine all configured receive buffers to check reception.
- Note 3. This flow will not provide most recently received data for the application. However, interrupt load is reduced because of less processing amount.
- Note 4. The overwrite function (FCNnMmSTRB.FCNnMmSSOW = 1) must not be used in this flow. Using this function may lose data consistency.

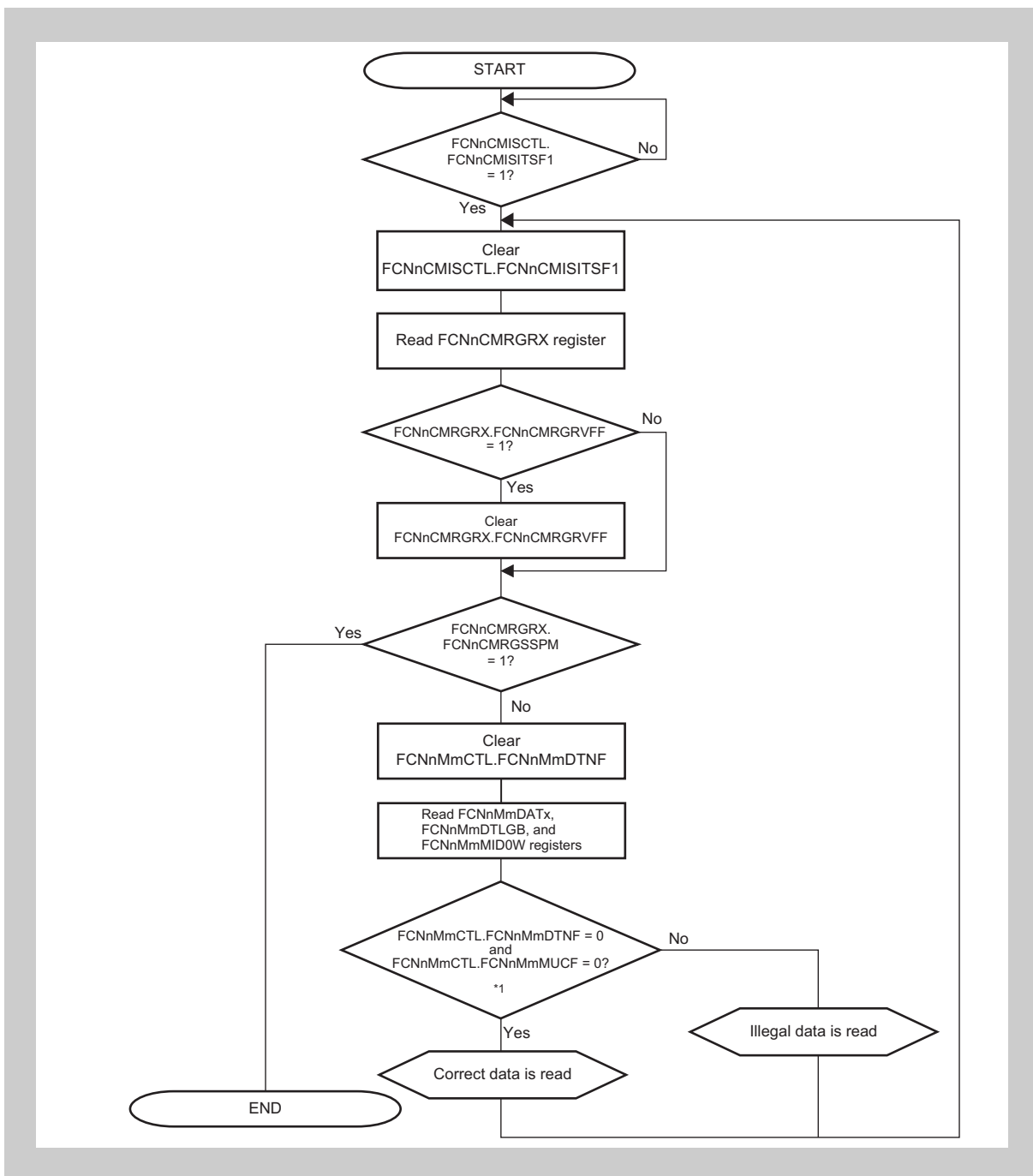

Figure 20-34 Reception via Software Polling

- Note 1. Check FCNnMmCTL.FCNnMmMUCF and FCNnMmCTL.FCNnMmDTNF bits using one read access.
- Note 2. Also check the FCNnGMCLSSMO flag at the beginning and at the end of the polling routine, in order to check the access to the message buffers as well as receive history list registers of the FCN module, in case a pending sleep mode had been executed. If FCNnGMCLSSMO is detected to be cleared at any check, re-set FCNnGMCLSSMO, discard actions and results of the processing, and then perform processing again.
- Note 3. Once FCNnCMRGRX.FCNnCMRGRVFF is set, the receive history list is inconsistent. Consider to examine all configured receive buffers to check reception.

20.14.4 Power Save Modes

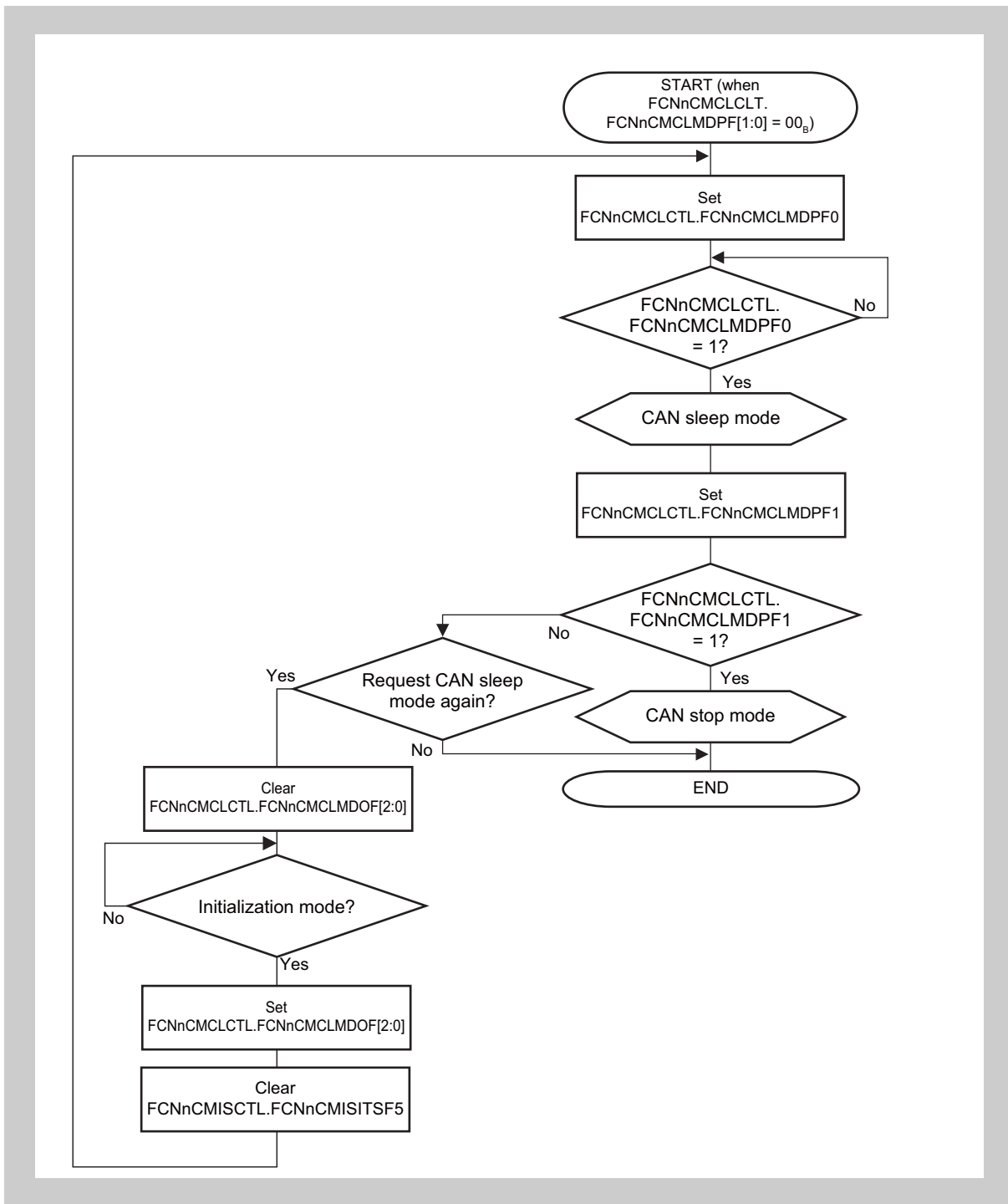

Figure 20-35 Setting FCN Sleep Mode and Stop Mode

Caution To abort transmission before making a request for transition to FCN sleep mode, perform transmission abort processing according to previously given flowcharts.

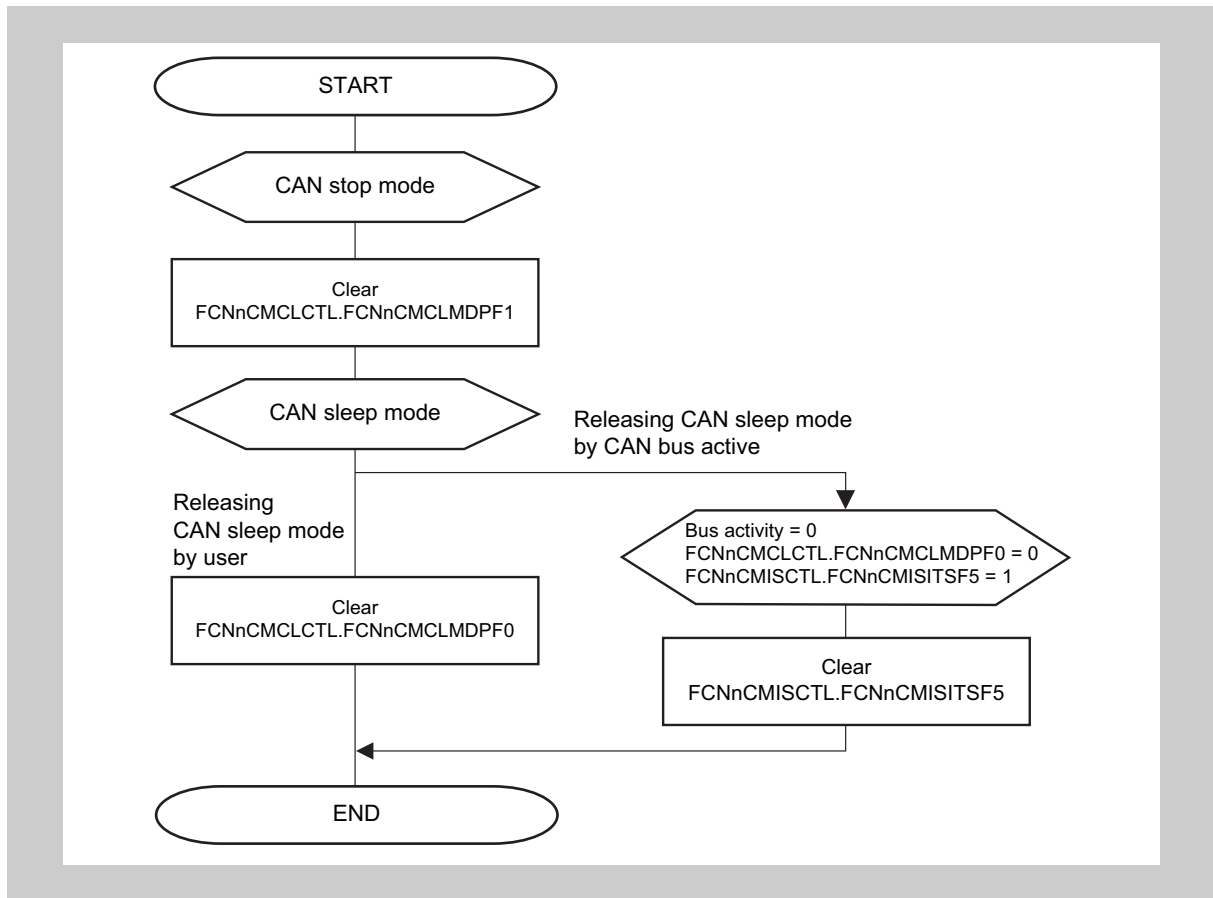

Figure 20-36 Releasing FCN Sleep Mode and Stop Mode

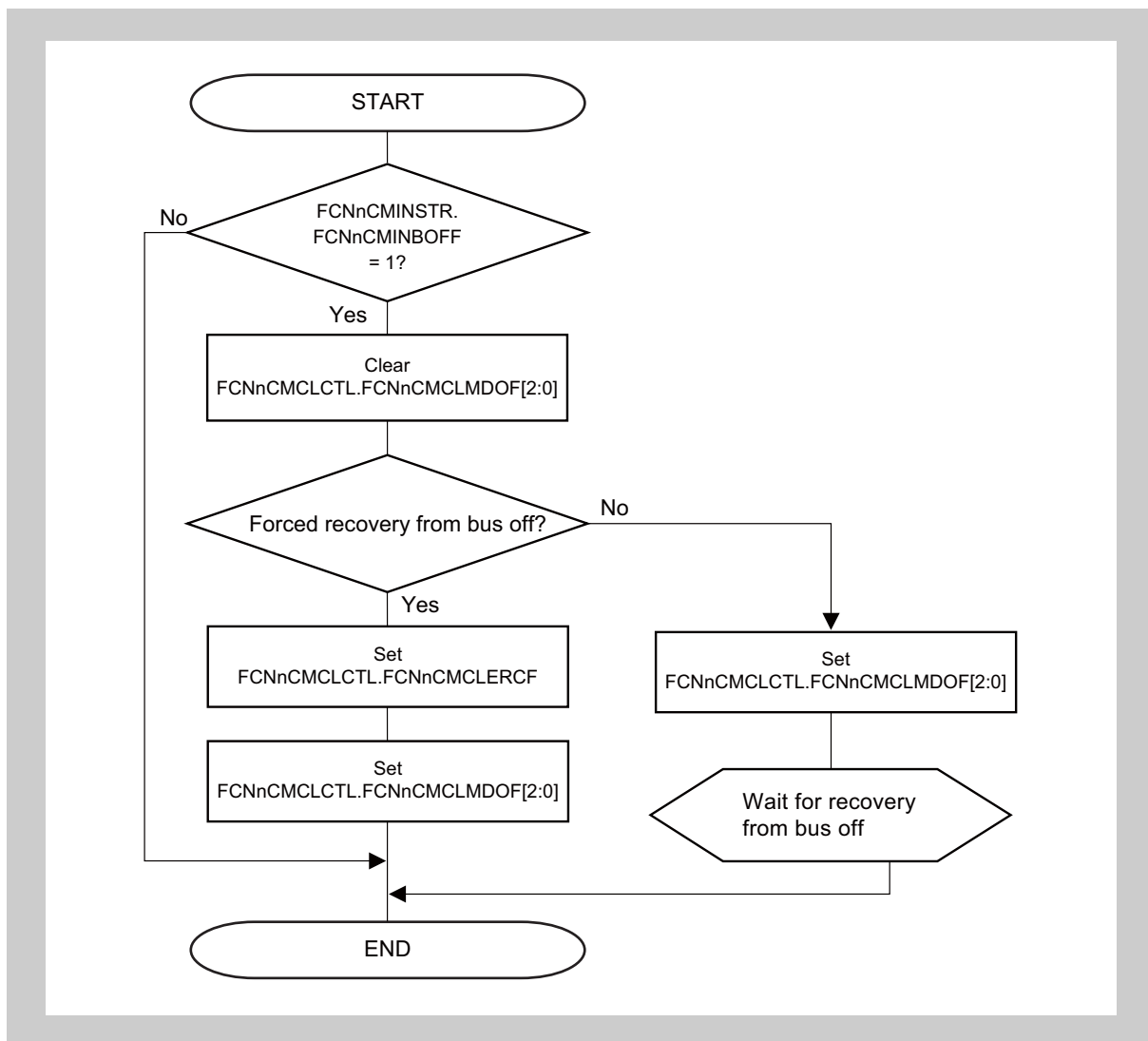

Figure 20-37 Recovery from Bus-off

Caution When the transmission from initialization mode to any operating mode is requested in the bus-off recovery sequence and bus-off recovery sequence is re-executed, the reception error counter is cleared. Therefore, it is necessary to detect 11 consecutive recessive-level bits 128 times again on the bus.

Note Operating mode: Normal operating mode, normal operating mode with ABT, receive-only mode, single-shot mode, self-test mode

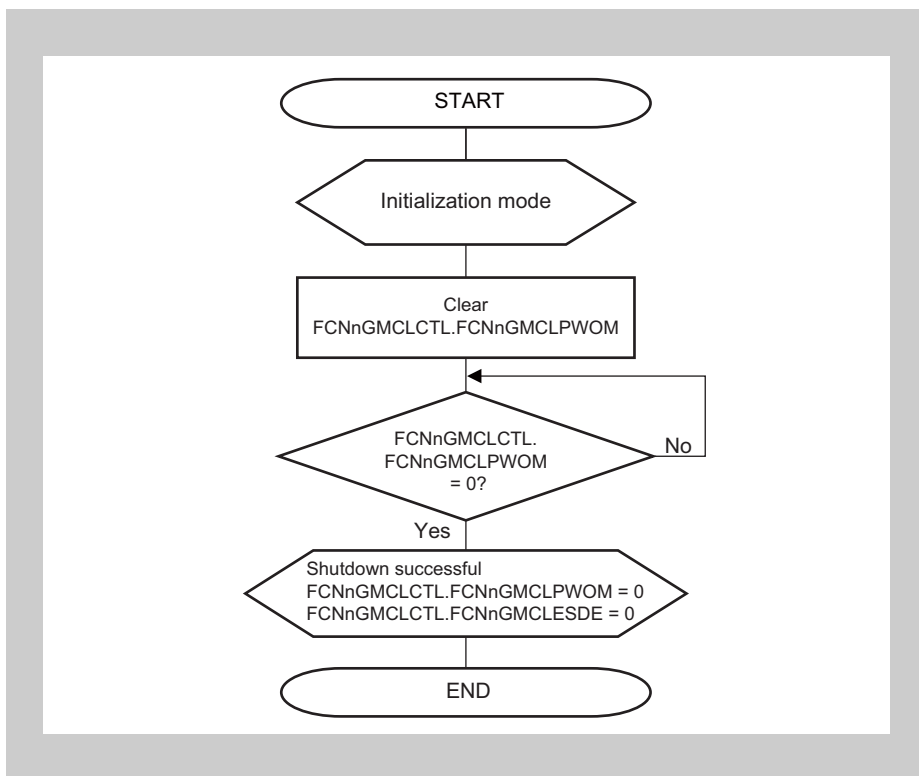

Figure 20-38 Normal Shutdown Processing

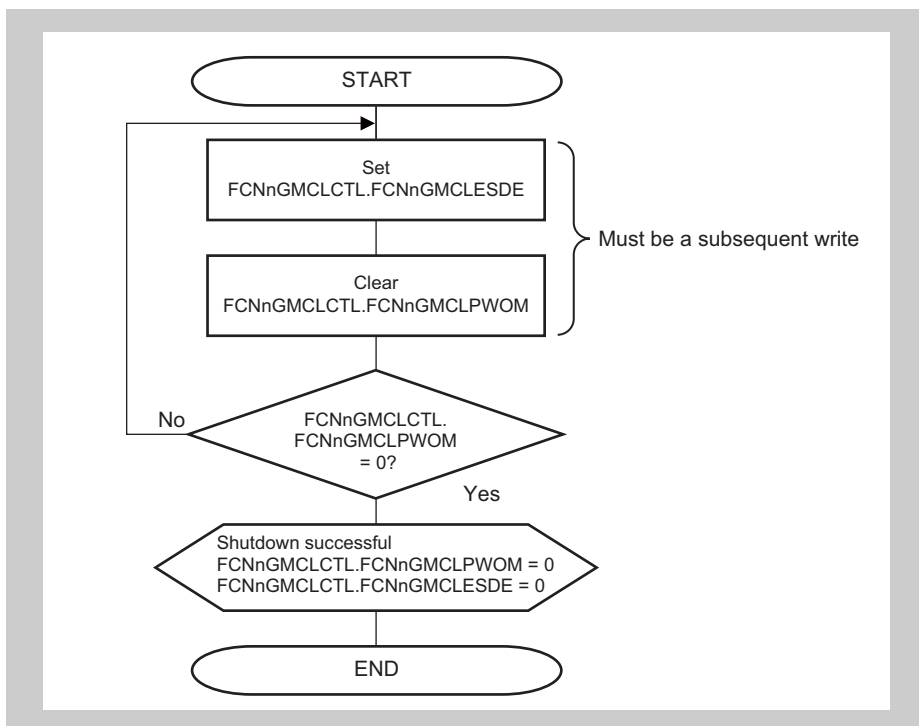

Figure 20-39 Forced Shutdown Processing

Caution Do not make read access or write access to any registers by software during a time period from the setting of the FCNnGMCLSEDE bit until clearing of the FCNnGMCLPWOM bit.

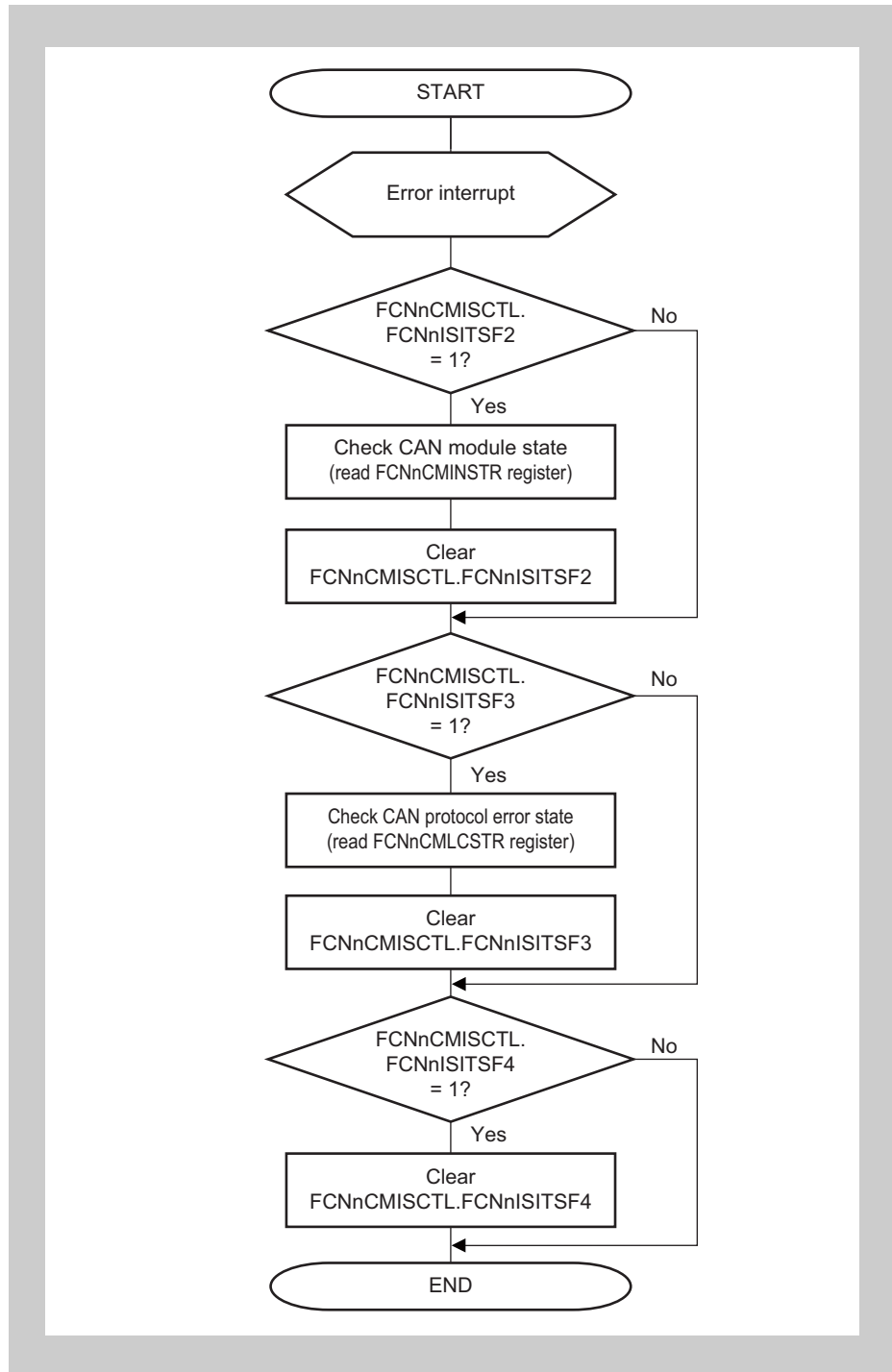

Figure 20-40 Error Handling

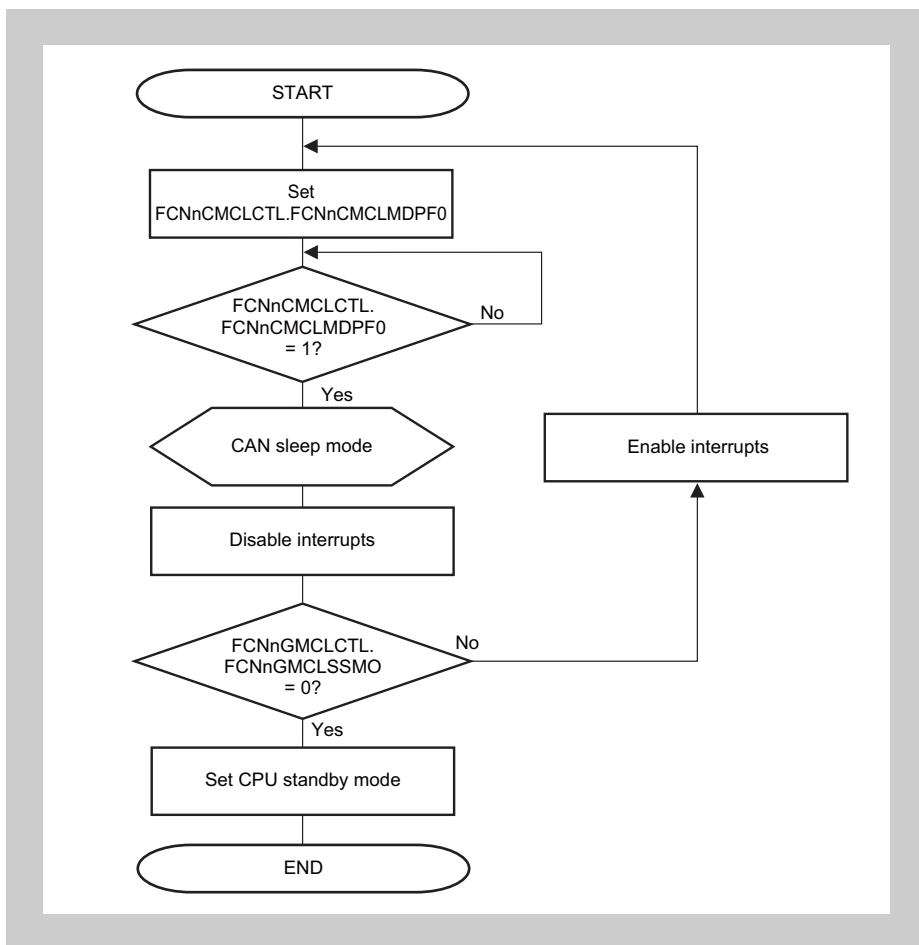

Figure 20-41 Setting CPU Standby (from FCN Sleep Mode)

- Note 1. Before setting the CPU to CPU standby mode, check whether the CPU is in FCN sleep mode.
However, after FCN sleep mode is checked, FCN sleep mode may be cancelled by wake-up from the CAN bus until the CPU is set to CPU standby mode.
- Note 2. A wake-up condition may occur on the CAN bus during a time period from checking of FCNnGMCLSSMO = 0 until CPU standby mode is set. In that case, the CAN module releases sleep mode, the FCNnCMISITSF5 bit is set, and a wake-up interrupt is generated if it is enabled.

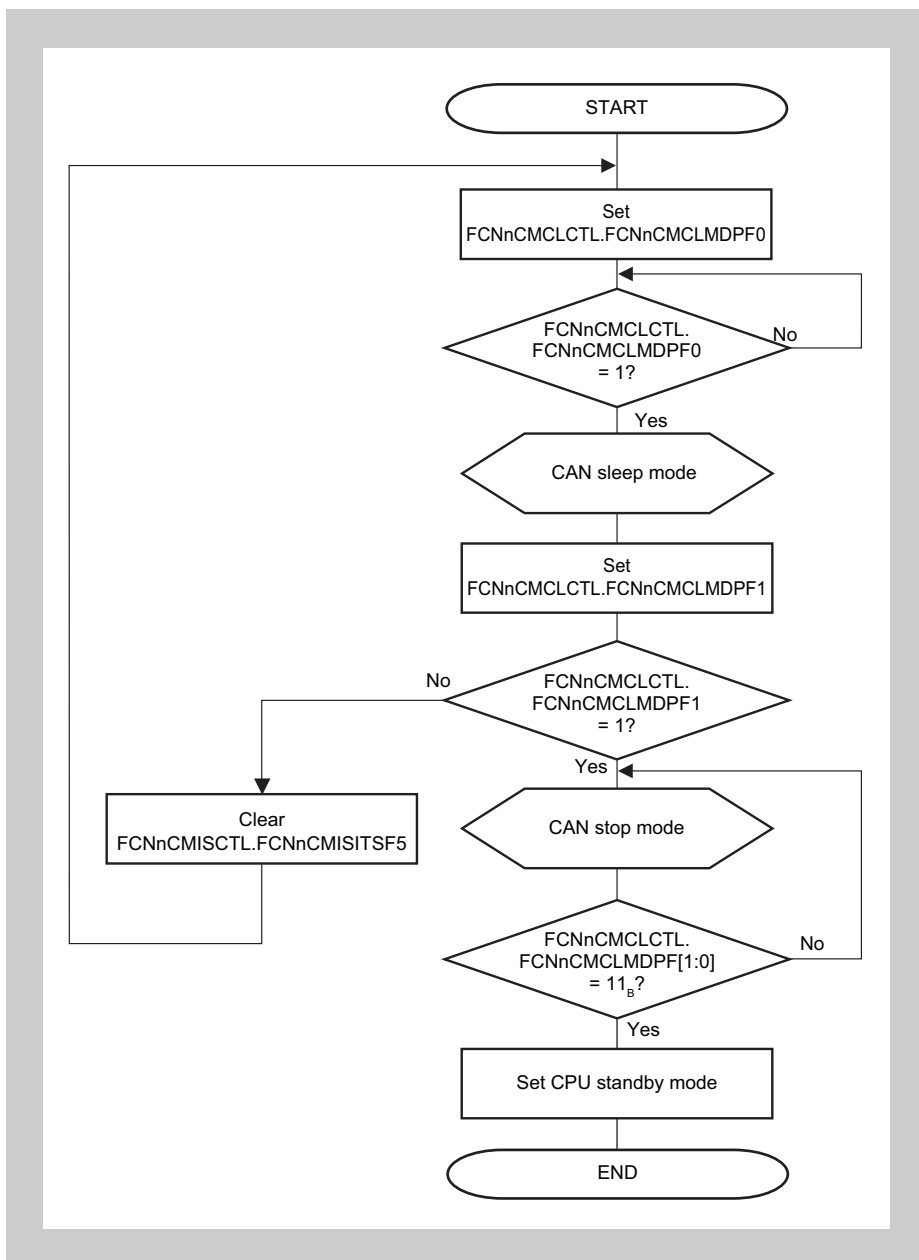

Figure 20-42 Setting CPU Standby (from FCN Stop Mode)

Caution FCN stop mode can be released only by setting FCNnCMCLCTL.FCnCMCLMDPF[1:0] to 01_B, and is not released by a change in the FCN bus state.

Section 21 Clocked Serial Interface G (CSIG)

This section contains a general description of the clocked serial interface G (CSIG).

21.1 CSIG Features

Instances This product has 2 instances of the clocked serial interface G blocks.

Table 21-1 Instances of CSIG

Clocked Serial Interface G	
Instances	2
Name	CSIG0, CSIG1

Instances index n Throughout this section, the individual instances of a clocked serial interface G is identified by the index “n” (n = 0, 1), for example, CSIGNCTL0 for the CSIGN control register 0.

Register addresses All CSIGN register addresses are given as address offsets to the individual base addresses <CSIGN_base0> and <CSIGN_base1>.

The base address <CSIGN_base> of each CSIGN is listed in the following table:

Table 21-2 Register Base Addresses <CSIGN_base0> and <CSIGN_base1>

CSIGN Instance	<CSIGN_base0> Address	<CSIGN_base1> Address
CSIG0	FF70 0000 _H	FFFF E400 _H
CSIG1	FF71 0000 _H	FFFF E500 _H

Clock supply The following clock is input on CSIGN.

Table 21-3 CSIGN Clock Supply

Channel of CSIGN	CSIGN Clock	Connected to
CSIG0, CSIG1	PCLK	Clock controller

Interrupt The clocked serial interface G can generate the following interrupt requests:

Table 21-4 CSIGn Interrupt Requests

CSIGn Signals	Function	Connected to
CSIGnTIC	Communication status interrupt	Interrupt controller INTCSIGnIC DMA
CSIGnTIR	Reception status interrupt	Interrupt controller INTCSIGnIR DMA
CSIGnTIRE	Reception error interrupt	Interrupt controller INTCSIGnIRE

I/O signals The I/O signals of the clocked serial interface G are listed in the following table.

Table 21-5 CSIGn I/O Signals

CSIGn Signals	Function	Connected to
CSIGnTSCK	Serial clock signal	Port CSIGnSC
CSIGnTSI	Serial data input signal	Port CSIGnSI
CSIGnTSO	Serial data output signal	Port CSIGnSO
CSIGnTRYI	Handshake input signal	Port CSIGnRYI
CSIGnTRYO	Handshake output signal	Port CSIGnRYO

Port Use CSIGn pins from the groups listed below.

Table 21-6 Port Groups for CSIGn

CSIGn Channel	Pin Name	Group	
		1	2
CSIG0	CSIG0SC	P1_9	—
	CSIG0SO	P1_8	—
	CSIG0SI	P1_7	—
	CSIG0RYI	P2_0	—
	CSIG0RYO	P4_4	—
CSIG1	CSIG1SC	P3_4	P4_4
	CSIG1SO	P3_3	P4_3
	CSIG1SI	P3_2	P4_2
	CSIG1RYI	P2_1	—
	CSIG1RYO	P4_5	—

21.2 Functional Overview

- Features summary**
- Three-line clock-synchronous serial communications
 - Master mode and slave mode selectable
 - Built-in baud rate generator
 - Maximum transmission speed:
 - In master mode: 8 Mbps
 - In slave mode: 6.6 Mbps (but no more than PCLK/6 Mbps)
 - Phase of clock and data selectable
 - Data transfer with MSB or LSB first selectable
 - Transfer data length selectable from 7 to 16 bits in 1-bit units
 - EDL (extended data length) function for transferring data with more than 16 bits
 - Three selectable transfer modes:
 - Transmit-only mode
 - Receive-only mode
 - Transmit/receive mode
 - Built-in handshake function
 - Separate transmit and receive buffers (two 16-bit registers)
 - Error detection (data consistency check, parity, overrun)
 - Three different interrupt request signals (CSIGNTIC, CSIGNTIR, CSIGNTIRE)
 - LBM (loop-back mode) function for self test

The block diagram shows the main components of the CSIG.

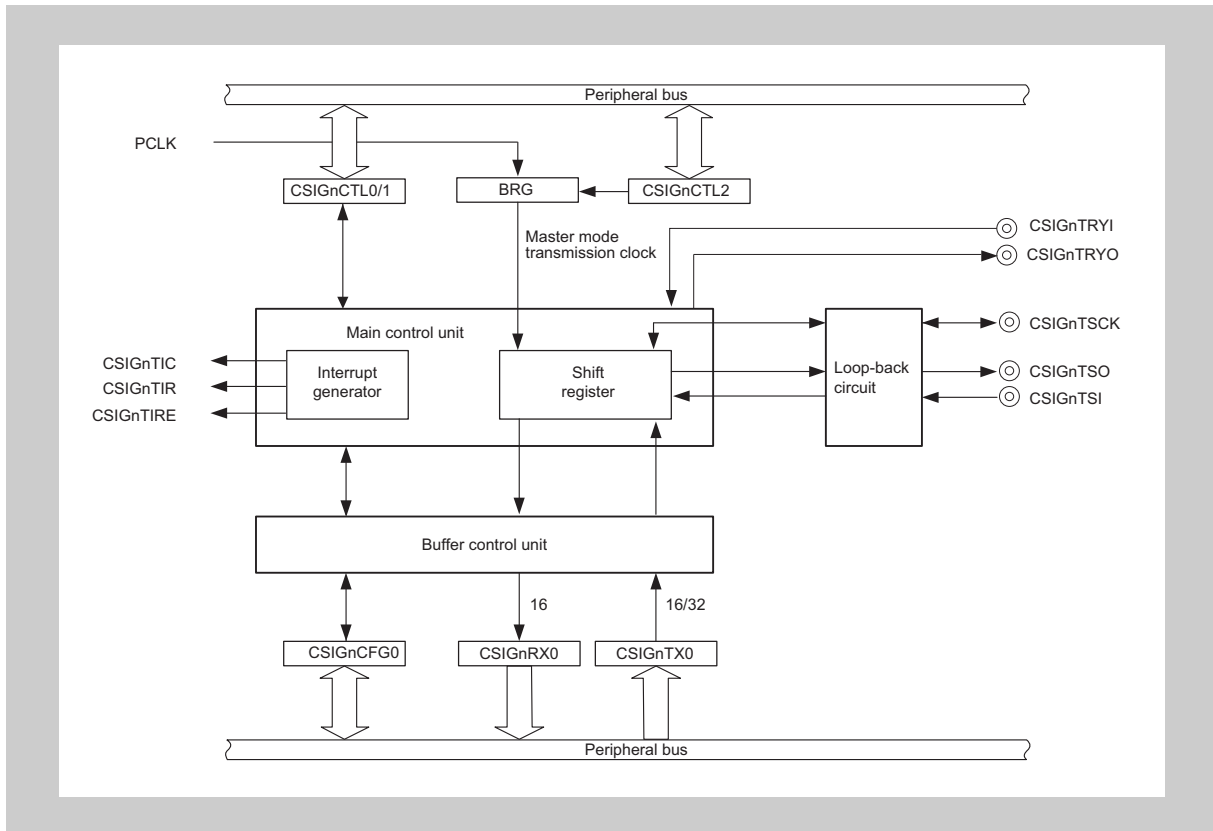

Figure 21-1 CSIG Block Diagram

In master mode, the serial communications clock (CSIGnTSCK) is generated by the internal baud rate generator (BRG). In slave mode, the module supplies the serial communications clock through CSIGnTSCK.

21.3 Functional Description

The clocked serial interface G module uses three signals for communication.

- Serial communications clock CSIGnTSCK (output in master mode, and input in slave mode)
- Data output signal CSIGnTSO
- Data input signal CSIGnTSI

Data transmission is bit-wise and serial and synchronous to the transmission clock.

The registers used for CSIG settings are listed in the following table.

Register	Function
CSIGnCTL0	Supplies or stops supply of the operating clock signal and enables or disables data transmission and reception.
CSIGnCTL1	Controls options like interrupt timing, extended data length, data consistency check, loop-back mode, handshake, etc.
CSIGnCTL2	Selects master or slave mode. In master mode, this also selects the rate of the signal produced by the baud rate generator.
CSIGnCFG0	Configures the communication protocol

21.3.1 Master/Slave Mode

CSIG operation in master mode or in slave mode depends on the setting of CSIGnCTL2.CSIGnPRS[2:0].

(1) Master Mode

In master mode, the serial communications clock is generated by the internal baud rate generator (BRG) and provided by signal CSIGnTSCK.

Setting a value other than 111_B in CSIGnCTL2.CSIGnPRS[2:0] and a value other than 0 in CSIGnCTL2.CSIGnBRG[11:0] makes the settings for the BRG effective.

The default level of CSIGnTSCK depends on the clock phase selection bit: it is high when CSIGnCTL1.CSIGnCKR = 0, and is low when CSIGnCTL1.CSIGnCKR = 1.

The example below shows the communication in master mode for 8 data bits, CSIGnCTL1.CSIGnCKR = 0, CSIGnCFG0.CSIGnDAP = 0, and MSB first.

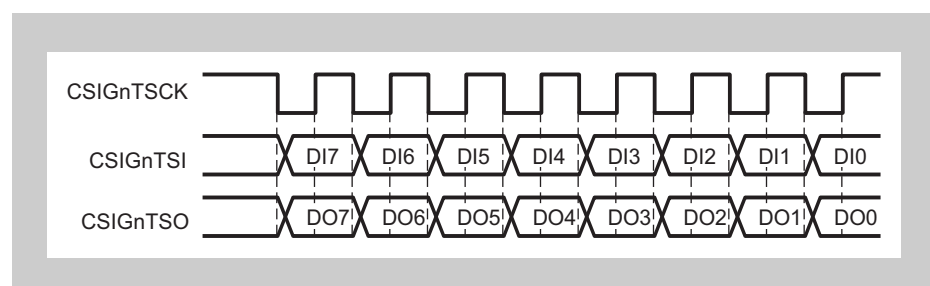

Figure 21-2 Transmit/Receive in Master Mode

(2) Slave Mode

In slave mode, another device is the communication master. The external clock is received by signal CSIGNTSCK. Transmit/receive operation starts as soon as a clock signal is detected.

Slave mode is selected by setting CSIGNCTL2.CSIGNPRS[2:0] to 111_B.

Note When using slave mode, disable the baud rate generator (BRG) by clearing bits CSIGNCTL2.CSIGNBRS[11:0].

The example below shows the communication in slave mode for 8 data bits, CSIGNCTL1.CSIGNCKR = 0, CSIGNCFG0.CSIGNDAP = 0, and MSB first:

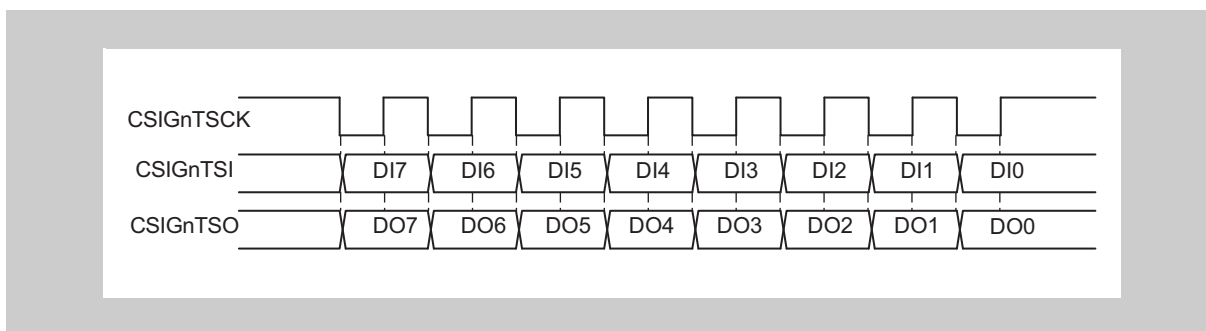

Figure 21-3 Transmit/Receive in Slave Mode

21.3.2 Master/Slave Connections

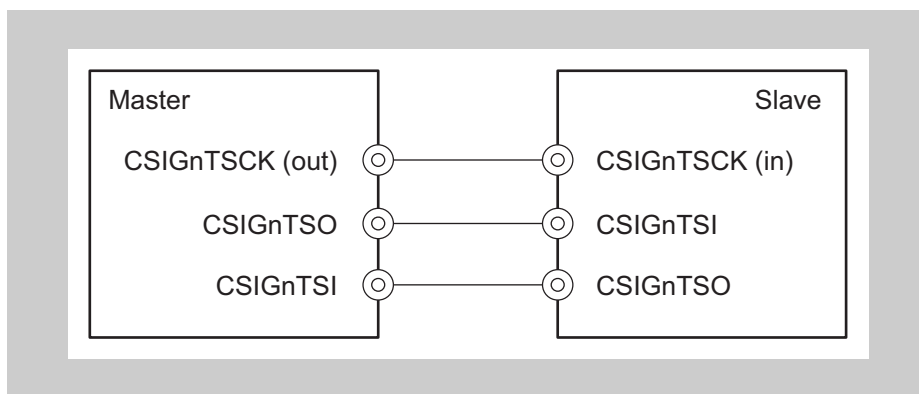

Figure 21-4 Simple Master/Slave Connection

21.3.3 Selection of Serial Communications Clock

In master mode, the baud rate for the serial communications clock is set by the CSIGNPRS[2:0] and CSIGNBRS[11:0] bits in the CSIGNCTL2 register.

The following figure shows a block diagram of the BRG.

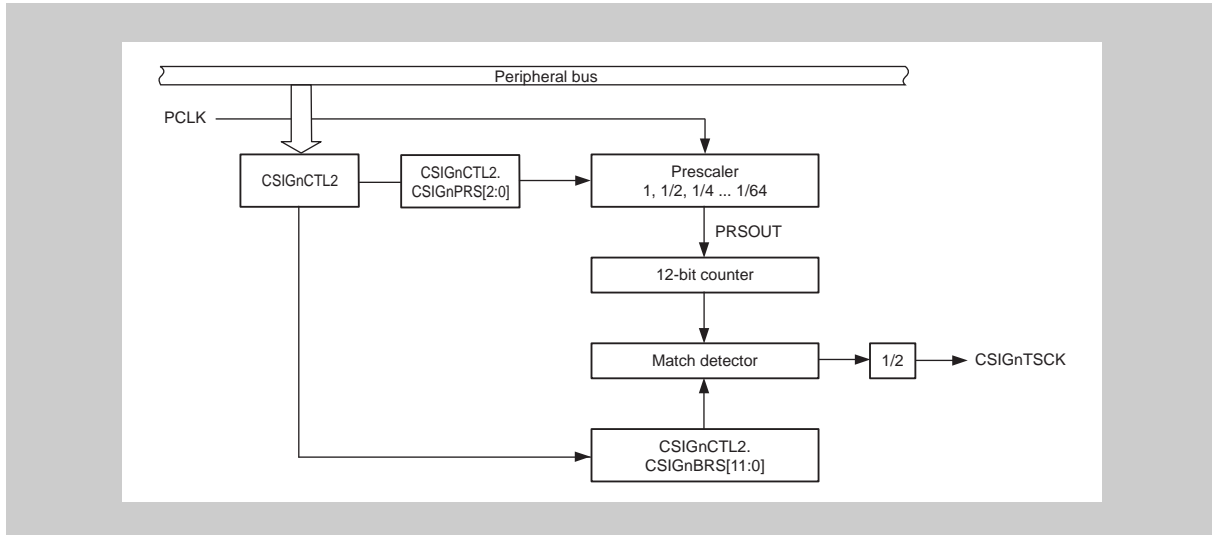

Figure 21-5 BRG Block Diagram

Clearing CSIGNCTL2.CSIGNBRS[11:0] disables the BRG.

Baud rate calculation The baud rate is calculated as follows:

$$\text{CSIGNTSCK} = \text{PCLK} / (2^m \times k \times 2)$$

Where,

$$m = \text{CSIGNCTL2.CSIGNPRS}[2:0] = 0 \text{ to } 6$$

$$k = \text{CSIGNCTL2.CSIGNBRS}[11:0] = 1 \text{ to } 4095$$

Baud rate upper/lower limits When setting the baud rate, note the following points.

- The baud rate must be no greater than 8.0 Mbps in master mode.
- The baud rate must be no greater than 6.6 Mbps in slave mode (and no greater than PCLK/6 Mbps). For operation with an external master, check that the baud rate from the master is in this range.
- Minimum baud rate in both modes is PCLK/524160.

21.3.4 Data Transfer Modes

(1) Transmit-Only Mode

Setting CSIGNCTL0.CSIGNTXE = 1 and CSIGNCTL0.CSIGNRXE = 0 puts the CSIG in transmit-only mode. After setting CSIGNCTL0.CSIGNTXE = 1, transmission starts when transmit data is written in the CSIGNTX0W or CSIGNTX0H register.

In master mode, transmission starts when transmit data is written in the CSIGNTX0W or CSIGNTX0H register.

In slave mode, transmission starts on clock input to CSIGNTSCK after the settings indicated above.

Caution In case transmit-only mode has been entered after any reception mode, the data in the CSIGNRX0 buffer becomes undefined after completion of the first transmission. Consequently the reception register CSIGNRX0 has to be read before changing to transmit-only mode.

(2) Receive-Only Mode

Setting CSIGNCTL0.CSIGNTXE = 0 and CSIGNCTL0.CSIGNRXE = 1 puts the CSIG in receive-only mode.

In master mode, once the CSIGNCTL0.CSIGNRXE is set to 1, reading from the CSIGNRX0 register causes transfer to start. As long as CSIGNBCTL0.CSIGNSCE = 1, reading from the receive data register (CSIGNRX0) triggers further reception.

In slave mode, reception starts when the communication clock CSIGNTSCK from the master is received.

Note In receive-only mode, avoid overwriting of data by reading previously received data from the reception register (CSIGNRX0) before new data arrive.

Moreover, the communication start bit CSIGNBCTL0.CSIGNSCE has to be set to 1 and then set back to 0 before reading the last received data from CSIGNRX0.

The recommended procedure is:

1. Before starting the first receive operation, read CSIGNRX0 (dummy data) with CSIGNBCTL0.CSIGNSCE = 1.
2. Wait for the reception interrupt CSIGNTIR.
3. Read CSIGNRX0 (received data).
If further data reception is to continue from step 2, continue to read all received data every time reception is completed.
Before reading the last of the received data from CSIGNRX0, set CSIGNBCTL0.CSIGNSCE = 0. For details, refer to Section 21.4 (6), CSIGNBCTL0 - CSIG Receive-Only Mode Control Register 0.

(3) Transmit/Receive Mode

Setting CSIGNCTL0.CSIGNTXE = 1 and CSIGNCTL0.CSIGNRXE = 1 puts the CSIG in transmit/receive mode.

Data transfer (transmission and reception) starts when transmit data is written to the CSIGNTX0W or CSIGNTX0H register.

21.3.5 Data Length Selection

(1) Data Length from 7 to 16 Bits

Transmission data length is selectable from 7 to 16 bits using the CSIGNDLS[3:0] bits in the CSIGNCFG0 register. The examples below show the communication with MSB first (CSIGNCFG0.CSIGNDIR = 0):

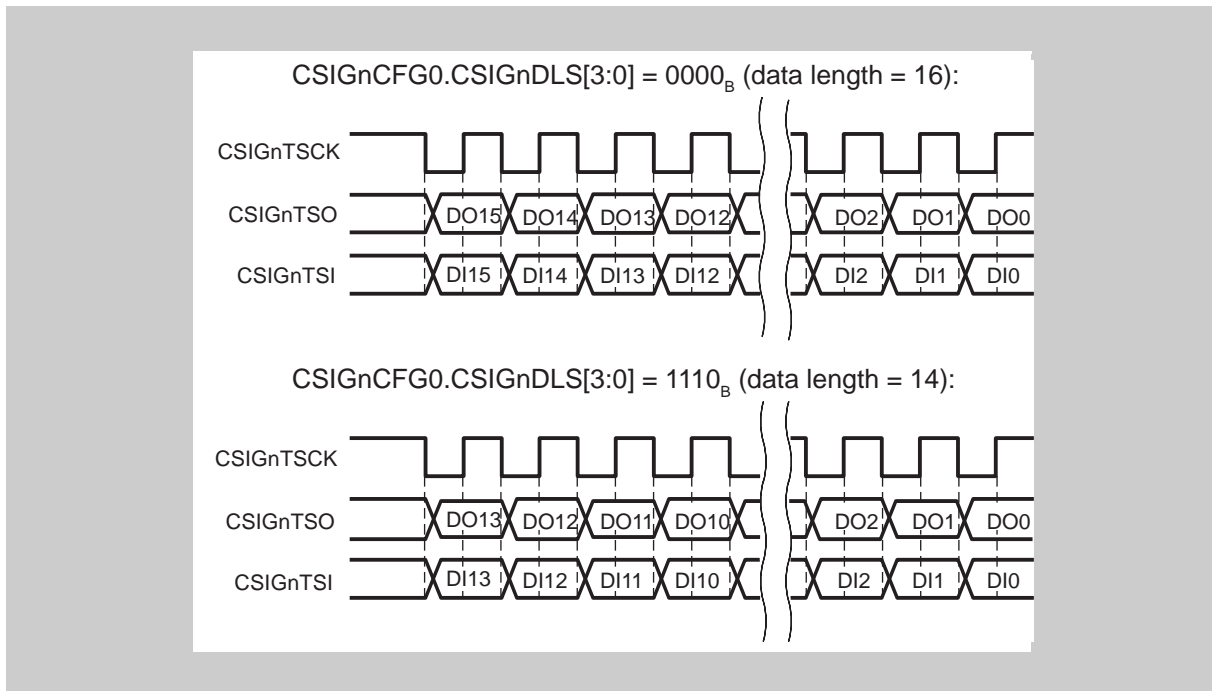

Figure 21-6 Data Length Select Function

(2) Data Length Greater than 16 Bits.

If the data to be transmitted/received exceed 16 bits, the extended data length (EDL) feature can be used.

The EDL function is enabled by setting the CSIGNCTL1.CSIGNEDLE bit to 1.

The EDL function works as follows:

- The data has to be broken into 16-bit blocks plus remainder. For example, a string of 42 bits would be broken into two 16-bit blocks plus 10 bits.
- The remainder defines the "data length" that has to be specified in the CSIGNCFG0.CSIGNDLS[3:0] bits.
- If a 16-bit block is to be transmitted, CSIGNTX0W.CSIGNEDL must be set to 1. In this case, data written to CSIGNTX0W are transmitted as 16-bit data regardless of setting of the CSIGNCFG0.CSIGNDLS[3:0] bits.
- The transfer is complete after the data with the specified data length (the remainder with CSIGNTX0W.CSIGNEDL = 0) has been sent.

Example Example for sending 40-bit data, for example the string 123456789A_H:

40 bits are split into 2 × 16 bits plus 8 bits.

- Initialize CSIGNCFG0.CSIGNDLS[3:0] = 8_D.
- To send the string 123456789A_H with MSB first, write the following sequence to CSIGNTX0W:
 - 2000 1234_H (CSIGNTX0W.CSIGNEDL = 1)
 - 2000 5678_H (CSIGNTX0W.CSIGNEDL = 1)
 - 0000 009A_H (CSIGNTX0W.CSIGNEDL = 0)

The following figure shows the timing.

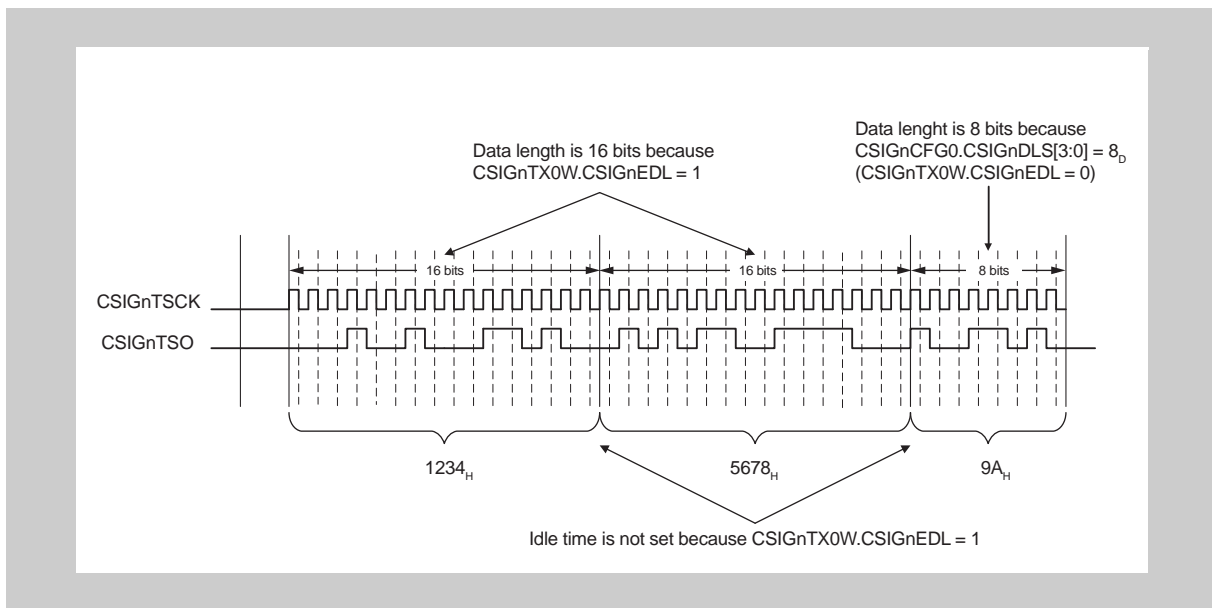

Figure 21-7 EDL Timing Diagram

- Note 1. It is not possible to send two consecutive data with a data length of less than 7 bits.
- Note 2. If parity is enabled, the parity bit is added after the last bit.
- Note 3. When sending data in LSB first mode/MSB first mode, write to the CSIGNTX0W register according to the relevant sequence below (when transmission data is 123456_H).
- CSIGNCFG0.CSIGNDIR = 1: LSB first
CSIGNTX0W = 2000 3456_H (CSIGNEDL = 1)
CSIGNTX0W = 0000 0012_H (CSIGNEDL = 0)
 - CSIGNCFG0.CSIGNDIR = 0: MSB first
CSIGNTX0W = 2000 1234_H (CSIGNEDL = 1)
CSIGNTX0W = 0000 0056_H (CSIGNEDL = 0)
- Note 4. Use of the EDL function in receive-only mode during slave operation is prohibited.
- Note 5. Setting a data length of less than 7 bits is only possible with the EDL function is in use.

21.3.6 Serial Data Direction Selection

The serial data direction is selectable using the CSIGNDIR bit in the CSIGNCFG0 register. The examples below show the communication for 8-bit data (CSIGNCFG0.CSIGNDLS[3:0] = 1000_B):

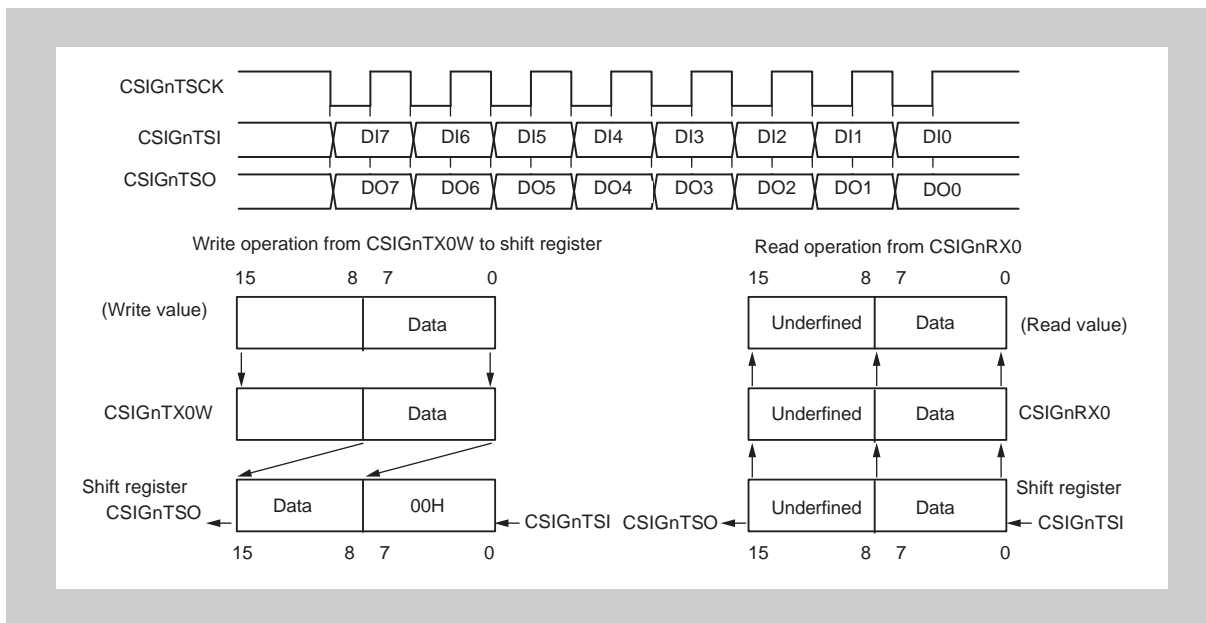

Figure 21-8 Serial Data Direction Select Function - MSB First (CSIGNCFG0.CSIGNDIR = 0)

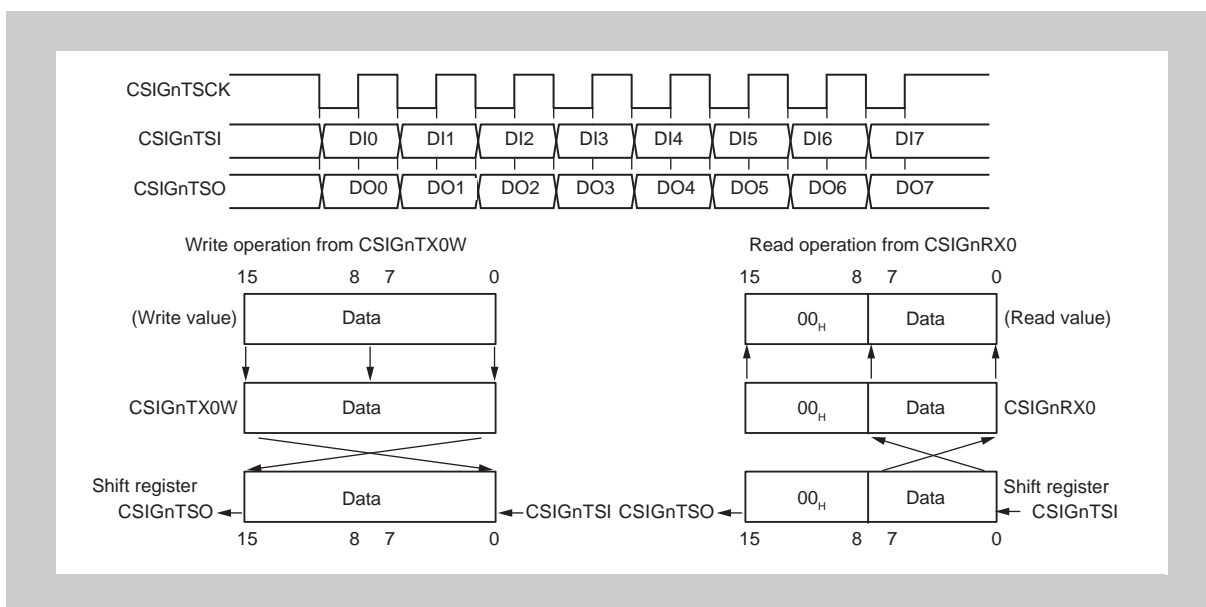

Figure 21-9 Serial Data Direction Select Function - LSB First (CSIGNCFG0.CSIGNDIR = 1)

21.3.7 Communication in Slave Mode

The following figure shows the communication signals and timings in slave mode.

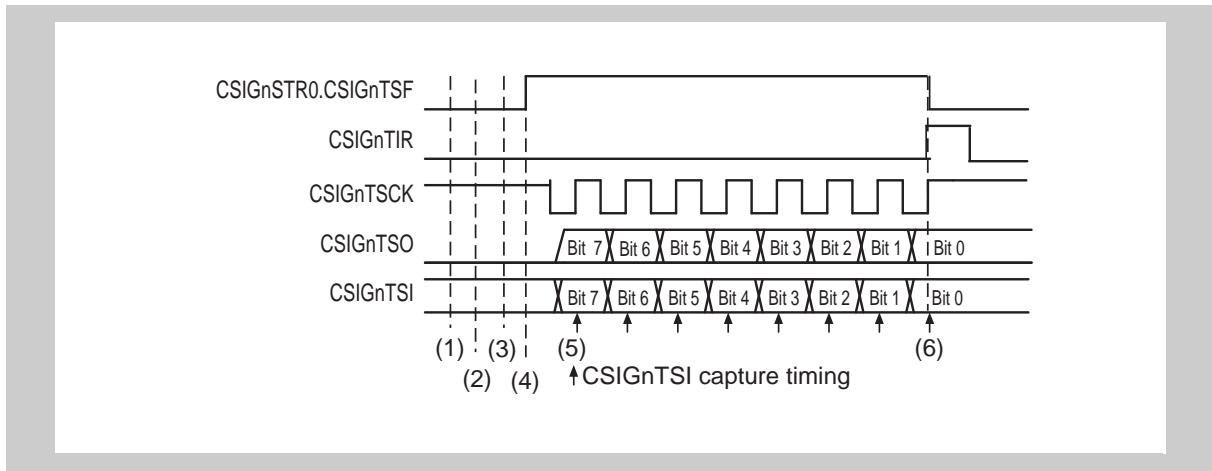

Figure 21-10 Receive/Transmit Communication Timing in Slave Mode

1. CSIG is put into slave mode by setting CSIGnCTL2.CSIGnPRS[2:0] = 111_B.
2. CSIGnCTL1.CSIGnCKR and CSIGnCFG0.CSIGnDAP are 0. Data length is 8 bits (CSIGnCFG0.CSIGnDLS[3:0] = 1000_B). Data direction is MSB first (CSIGnCFG0.CSIGnDIR = 0).
3. When CSIG is set to transmit/receive mode (CSIGnCTL0.CSIGnPWR = 1, CSIGnCTL0.CSIGnTXE = 1, and CSIGnCTL0.CSIGnRXE = 1), communication start is enabled.
4. The transfer status flag (CSIGnSTR0.CSIGnTSF) is automatically set when data for transfer are written to the transmission register (CSIGnTX0W or CSIGnTX0H).
5. When an external clock signal is detected as the CSIGnTSCK signal, the slave immediately starts transferring data through the CSIGnTSO pin and capturing data from the CSIGnTSI pin.
6. Reception of the last of the data is complete.
7. Received data are read.

21.3.8 CSIG Interrupts

CSIG can generate the following interrupts:

- CSIGnTIC
- CSIGnTIR
- CSIGnTIRE

(1) CSIGnTIC (Communication Interrupt)

This interrupt is normally generated after every data transfer. It can be used to trigger a DMA for writing new transmission data to register CSIGnTX0W or CSIGnTX0H.

The following example assumes master mode and a setting of CSIGnCTL1.CSIGnSIT = 0 (no interrupt delay), CSIGnCTL1.CSIGnCKR = 0, CSIGnCFG0.CSIGnDAP = 0 (normal clock and data phase), CSIGnCFG0.CSIGnDLS[3:0] = 1000_B (8-bit data length), and CSIGnCTL1.CSIGnSLIT = 0 (normal interrupt timing).

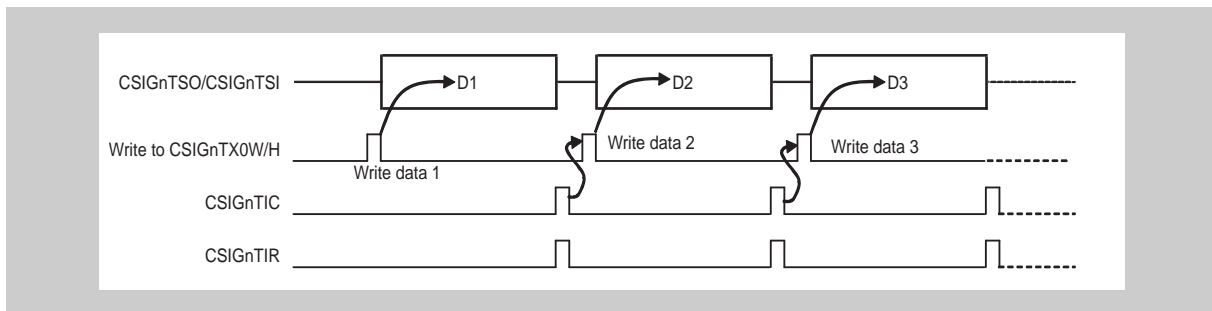

Figure 21-11 Generation of CSIGnTIC after Communication (CSIGnCTL1.CSIGnSLIT = 0)

However, CSIGnTIC can also be set up to occur when the CSIGnTX0 or CSIGnTX0H register is free for the next data. This is specified by setting CSIGnCTL1.CSIGnSLIT = 1.

This mode allows more efficient data transfers.

The effect is illustrated in the figure below.

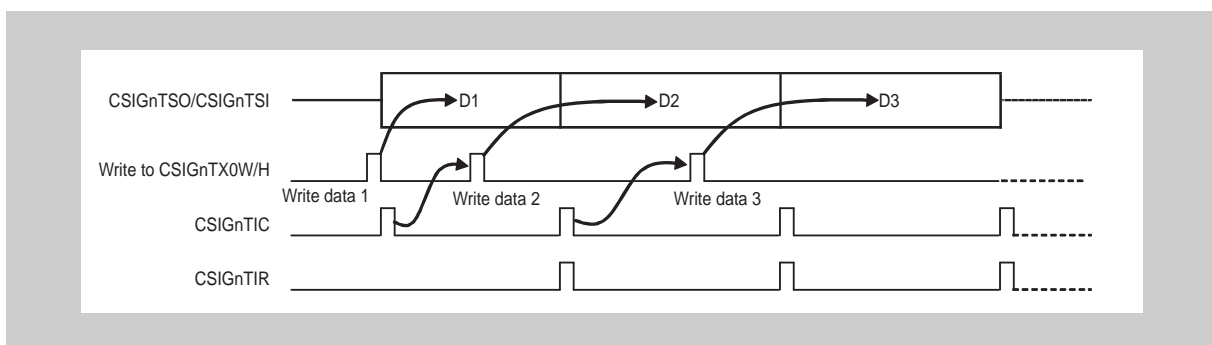

Figure 21-12 Generation of CSIGnTIC at the Beginning of Communication

(2) CSIGNTIR (Reception Interrupt)

This interrupt is generated in receive-only mode or transmit/receive mode after data has been received and is available in the reception register.

The following example assumes master mode and a setting of CSIGNCTL1.CSIGNSIT = 0 (no interrupt delay), CSIGNCTL1.CSIGNCKR = 0, CSIGNCFG0.CSIGNDAP = 0 (normal clock and data phase), and CSIGNCFG0.CSIGNDLS[3:0] = 1000_B (8-bit data length).

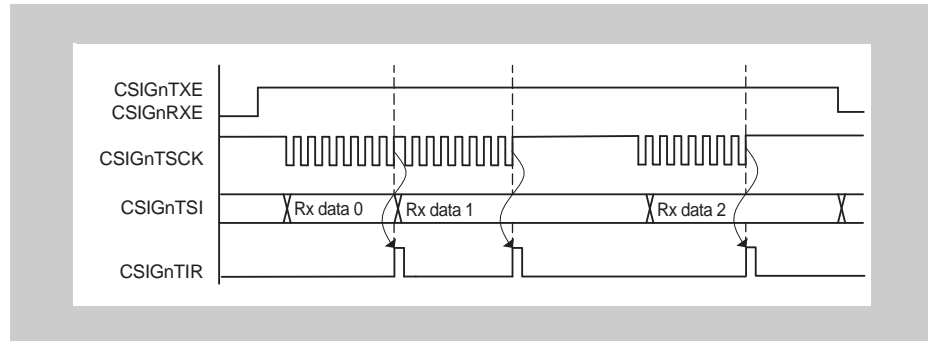

Figure 21-13 Generation of CSIGNTIR

(3) CSIGNTIRE (Reception Error Interrupt)

This interrupt is generated whenever the following errors are detected.

- Parity error
- Data consistency error
- Overrun error

Table 21-7 Data Error Types

Error Type	Communication Status after Error Interrupt
Parity error	Interrupt is generated and communication continues
Data consistency error	Interrupt is generated and communication continues
Overrun error	Interrupt is generated and communication is stopped

The type of error that caused the generation of CSIGNTIRE is indicated in register CSIGNSTR0.

For details on the various error types, refer to Section 21.3.11, Error Detection.

(4) All Interrupts Delay

In master mode, delaying all interrupts from the master by half a cycle of the transmission clock (CSIGNTSCK) is possible. This function is not available in slave mode.

Set the CSIGNCTL1.CSIGNSIT bit to 1 to specify this delay.

The following settings are assumed in the figure below showing an example of using the interrupt delay: CSIGNCTL1.CSIGNSIT = 1 (enabling interrupt delay), CSIGNCTL1.CSIGNCKR = 0, CSIGNCFG0.CSIGNDAP = 0 (normal clock and data phases), and CSIGNCFG0.CSIGNDLS[3:0] = 1000_B (8-bit data length).

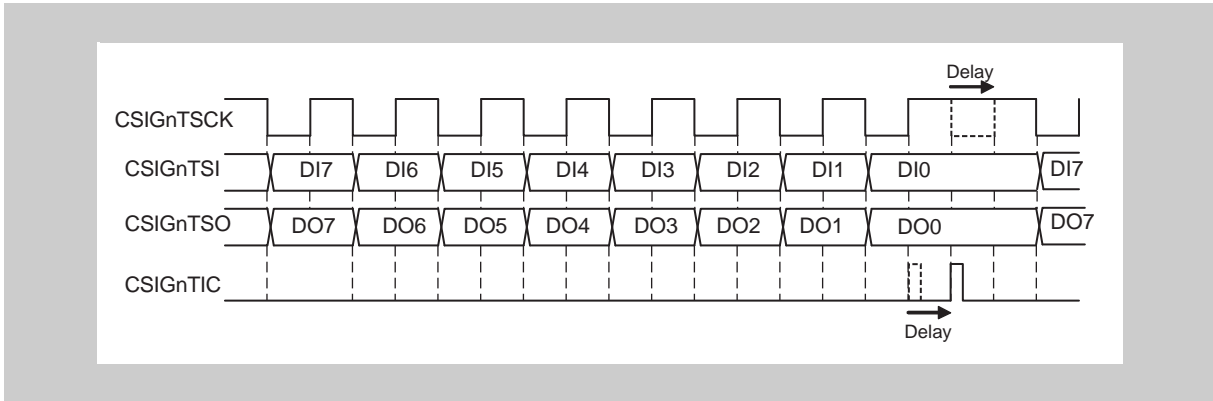

Figure 21-14 Interrupt Delay Function (CSIGnCTL1.CSIGnSIT = 1)

21.3.9 Handshake Function

CSIG features a handshake function to synchronize the master and the slave devices. This function can be enabled/disabled by bit CSIGnCTL1.CSIGnHSE.

For handshake, the signals CSIGnTRYI/CSIGnTRYO are used.

The timing depends on the data phase selection bit CSIGnCFG0.CSIGnDAP.

(1) Slave Mode

When CSIGnCTL1.CSIGnHSE = 1, the slave outputs CSIGnTRYO = 0 when it is busy. This happens when previously received data is still in the CSIGnRX0 register, and new data cannot be copied from the shift register to CSIGnRX0 (CSIGnRX0 full condition).

The following examples assume 8-bit data length.

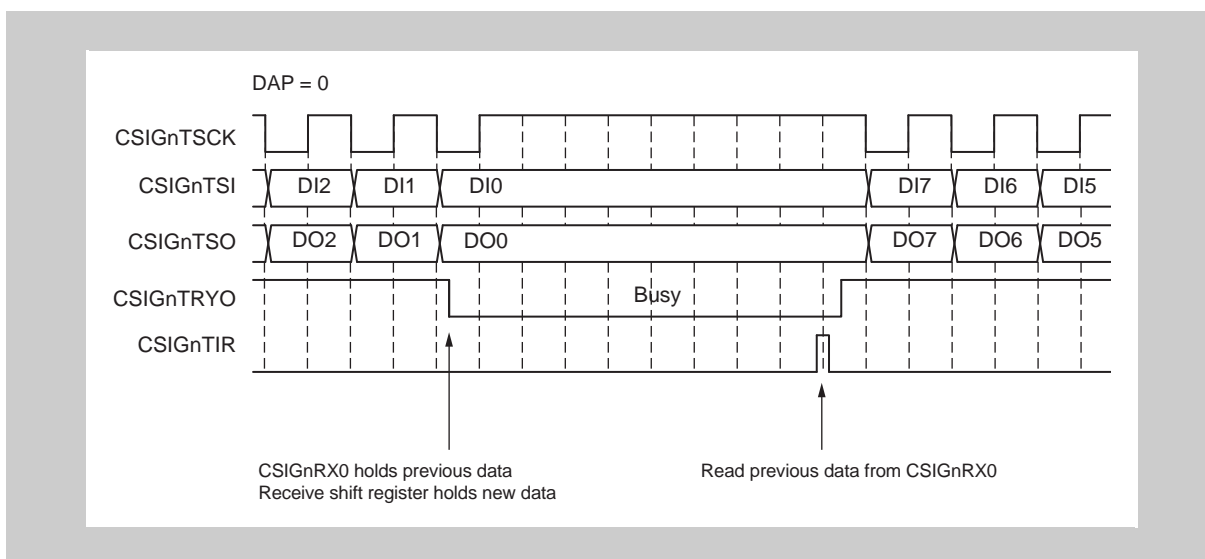

Figure 21-15 Ready/Busy Signal from Slave (CSIGnCFG0.CSIGnDAP = 0)

As long as the slave is busy, the master has to wait (i.e. suspend the transmission clock). The slave sets CSIGnTRYO to high (“ready”) as soon as the reception register CSIGnRX0 has been read.

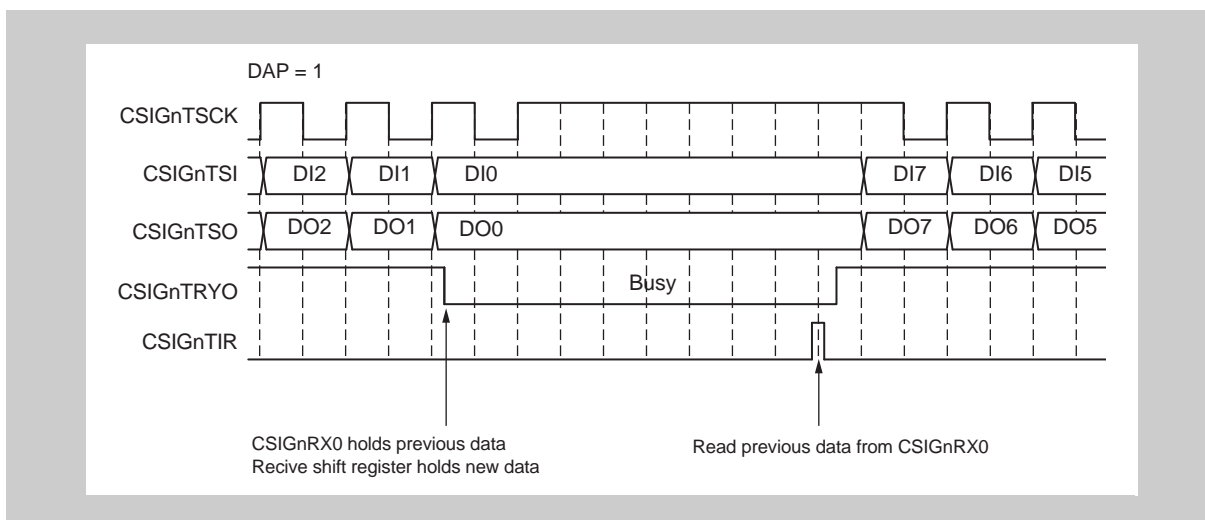

Figure 21-16 Ready/Busy Signal from Slave (CSIGnCFG0.CSIGnDAP = 1)

(2) Master Mode

When the master detects CSIGNTRYI = 0, the following transfer is put on hold, and the master goes into wait status. It suspends the clock at CSIGNTSCK.

The CSIGNTRYI level is checked at each half clock cycle of CSIGNTSCK.

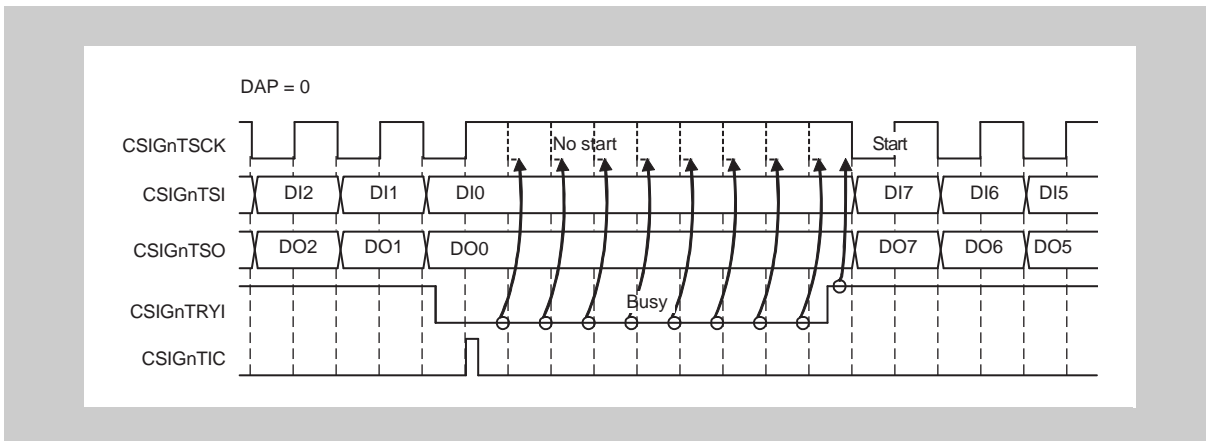

Figure 21-17 Master's Response to CSIGNTRYO Signal from Slave (CSIGNCFG0.CSIGNDAP = 0)

A low level from the slave on the CSIGNTRYI pin of the master while data transfer is in progress causes the master to suspend generation of the serial clock after the current transfer is complete.

The master resumes the transfer as soon as the level on the CSIGNTRYI is high (indicating that the slave is "ready").

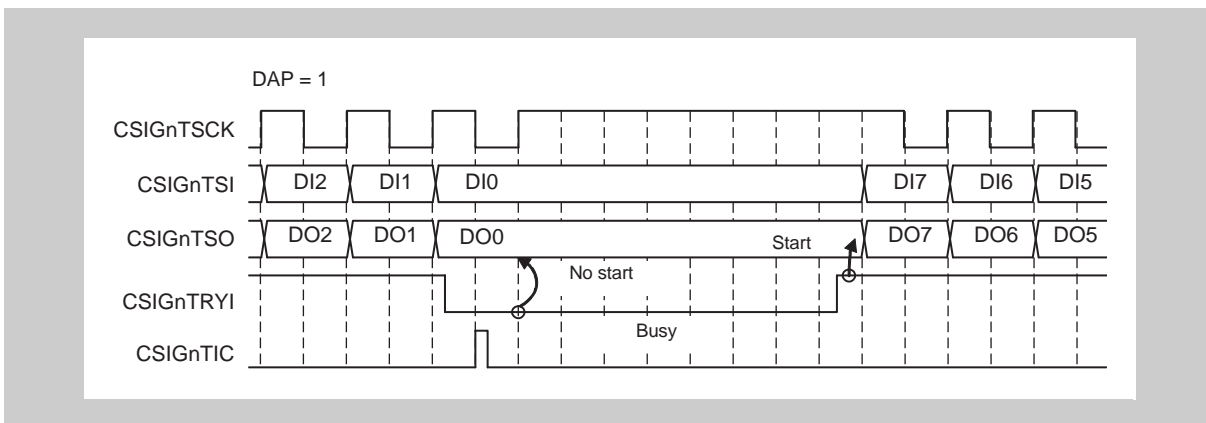

Figure 21-18 Master's Response to CSIGNTRYO Signal from Slave (CSIGNCFG0.CSIGNDAP = 1)

Caution CSIGNTRYI must be pulled down by the slave before the next transfer starts. Even if the signal is pulled down by the slave during the transfer, the transfer will be finished.

21.3.10 Loop-Back Mode

Loop-back mode is a special mode for self-testing. This feature is only available in master mode.

During operation in this mode, the transmission and reception signal lines are internally connected, as shown in the figures below. The CSIGnTSCK, CSIGnTSO, and CSIGnTSI signals are disconnected from the port pins. In addition, the CSIGnTSO output is fixed to the low level, and CSIGnTSCK is set to the inactive state. The rest of CSIG works as in normal operation.

In order to test the CSIG, set the CSIGnCTL1.CSIGnLBM bit to 1, carry out normal transfer operations, and then check that the received data is the same as the transmitted data.

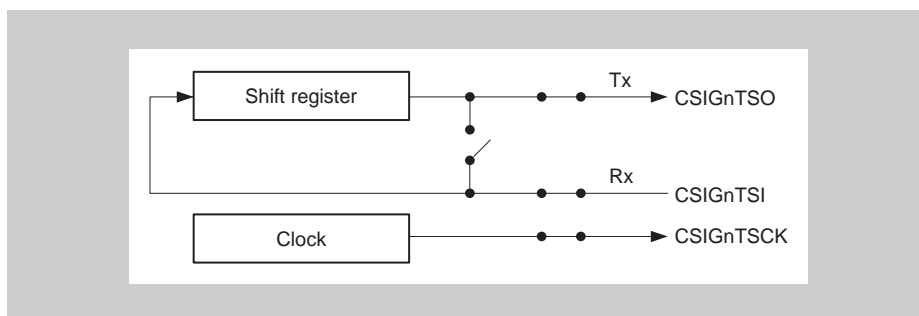

Figure 21-19 Normal Operation

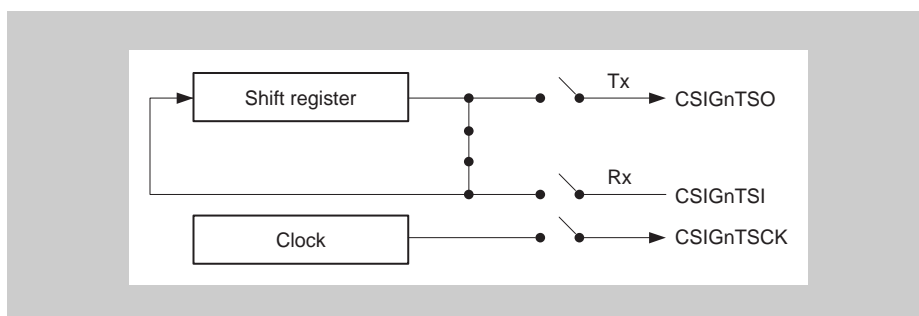

Figure 21-20 Operation in Loop-Back Mode

21.3.11 Error Detection

CSIG can detect three error types:

- Data consistency error (transmission data)
- Parity error (received data)
- Overrun error

Error checking can be individually enabled/disabled for each type.

If one of these errors is detected, the CSIGNTIRE interrupt signal is generated and the flag corresponding to the detected error is set.

(1) Data Consistency Check

The purpose of the data consistency check is to ensure that the data physically sent to the output pin is identical to the original data that was copied to the shift register.

The data consistency check can be enabled/disabled by the CSIGNCTL1.CSIGNDCS bit. It is not active if data transmission is disabled (CSIGNCTL0.CSIGNTXE = 0).

When data consistency checking is being applied, data transferred from the CSIGNTX0W or CSIGNTX0H register to the shift register are also copied to a separate register. In addition, the physical levels on CSIGNTSO are written into their own shift register.

After completion of the transmission, the transmitted data is compared with the original transmission data.

A mismatch is considered a data consistency error, in which case the following steps proceed:

- The CSIGNTIRE interrupt signal is generated.
- The data consistency error flag (CSIGNSTR0.CSIGNDCE) is set.

Caution For data consistency checking, set the bit in the PIPCn register to which the CSIGNTSO pin is assigned to 0, and set the relevant bit in the PBDCn register to 1.

The function is illustrated in the following block diagram.

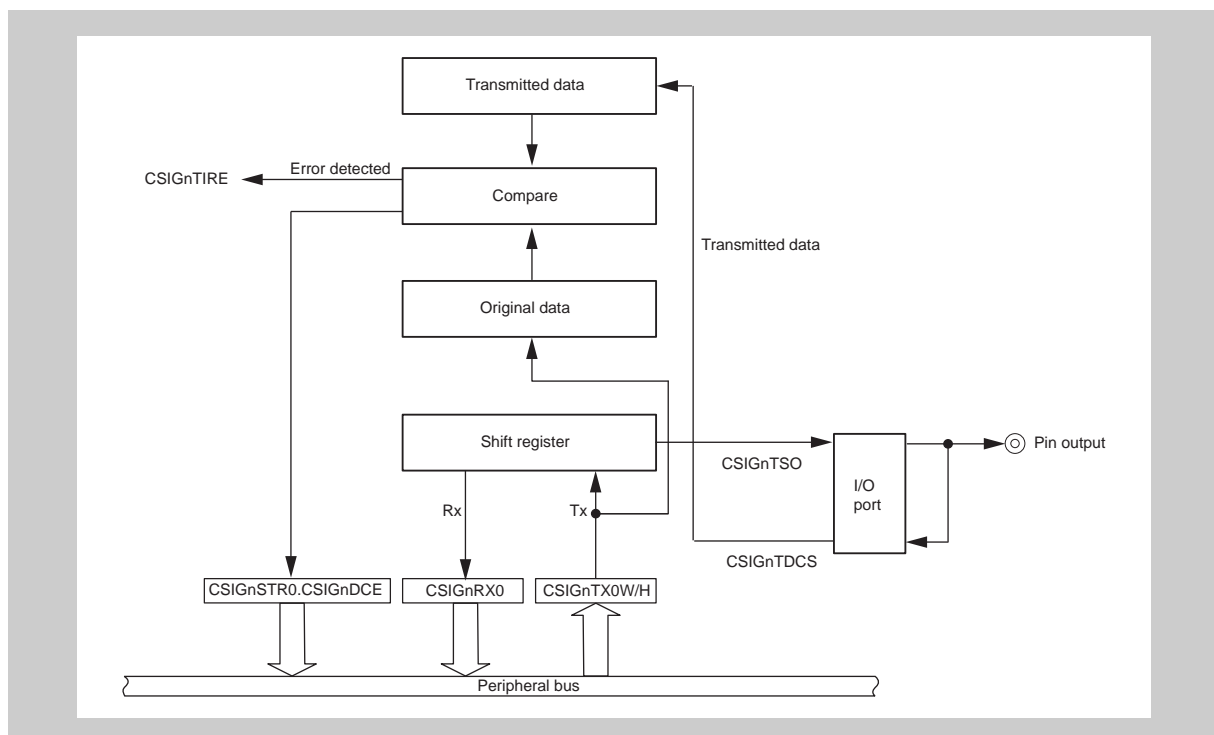

Figure 21-21 Functional Block Diagram of the Data Consistency Check

(2) Parity Check

CSIG can append a parity bit to the last data bit (even if extended data length is used).

The use and type of parity is specified in CSIGNCFG0.CSIGNPS[1:0].

Parity check is enabled if CSIGNCFG0.CSIGNPS[1] = 1.

The parity bit is checked after reception is complete. If a parity error occurs:

- Interrupt CSIGNTIRE is generated.
- The parity error flag (CSIGNSTR0.CSIGNPE) is set.

The following figure shows an example.

Data length is 8 bits. The data transmitted is 05_H and 35_H. Parity type is odd.

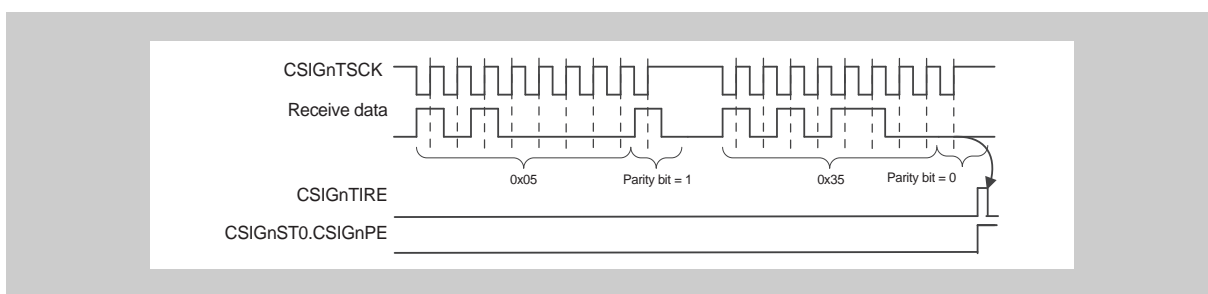

Figure 21-22 Parity Check Example

The parity bit for the first of the data to be received is 1. There is no parity error, because the total number of ones (including the parity bit) is odd.

The parity bit for the subsequently received data is 0. This is detected as a parity error, because the total number of ones (including the parity bit) is even.

(3) Overrun Error

This error occurs when new data are received in the reception register (CSIGNRX0) but previously received data have not been read.

The overrun error is not generated if data reception is disabled (CSIGNCTL0.CSIGNRXE = 0) or in master mode.

If overrun occurs:

- Interrupt CSIGNTIRE is generated
- The overrun error flag (CSIGNSTR0.CSIGNOVE) is set.
- Communication is stopped

The following figure illustrates the function.

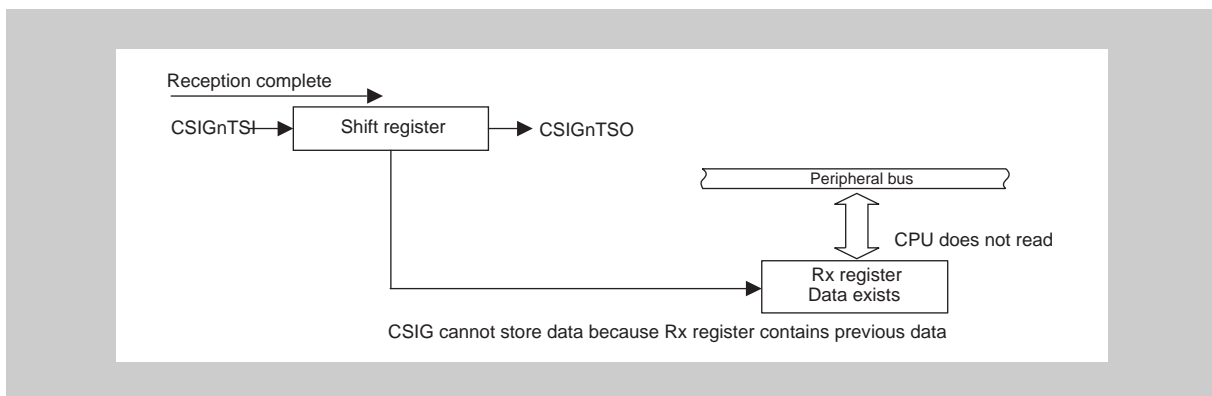

Figure 21-23 Overrun Error Detection

The following figure illustrates an example where:

- Rx data 3 was not read
- Rx data 4 was received, but cannot be stored

Thus an overrun error occurs.

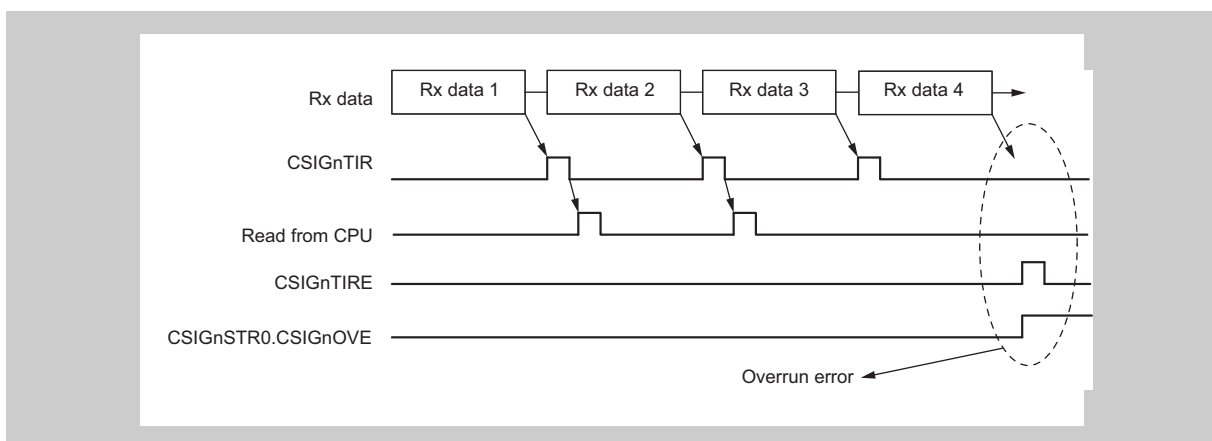

Figure 21-24 Overrun Error Detection - Example

Note Overrun errors from trying to overwrite received data in slave mode can be avoided through handshaking.

When handshake is used in slave mode, the receiver (slave) signals to the transmitter (master) that it is busy. The transmitter then waits until the receiver has read its reception register and is ready again.

Refer to Section 21.3.9, Handshake Function for details.

21.4 CSIG Control Registers

The CSIGn is controlled and operated by means of the following registers.

Table 21-8 CSIGn Register Overview

Register name	Symbol	Address
Control register 0	CSIGnCTL0	<CSIGn_base1> + 00 _H
Control register 1	CSIGnCTL1	<CSIGn_base0> + 10 _H
Control register 2	CSIGnCTL2	<CSIGn_base0> + 14 _H
Status register 0	CSIGnSTR0	<CSIGn_base1> + 04 _H
Status clear register 0	CSIGnSTCR0	<CSIGn_base1> + 08 _H
Receive-only mode control register 0	CSIGnBCTL0	<CSIGn_base1> + 80 _H
Configuration register 0	CSIGnCFG0	<CSIGn_base0> + 1010 _H
Transmission register 0 for word access	CSIGnTX0W	<CSIGn_base1> + 84 _H
Transmission register 0 for half word access	CSIGnTX0H	<CSIGn_base1> + 88 _H
Reception register 0	CSIGnRX0	<CSIGn_base1> + 8C _H

<CSIGn_base> The base addresses <CSIGn_base0> and <CSIGn_base1> of the CSIGn are defined in Section 21.1 under the key word "Register addresses".

(1) CSIGNCTL0 - CSIG Control Register 0

This register controls the operation clock and enables/disables transmission and reception.

Access This register can be read/written in 1-bit and 8-bit units.

Address <CSIGN_base1> + 00_H

Initial value 00_H

This register is initialized by a reset from any source.

7	6	5	4	3	2	1	0
CSIGN PWR	CSIGN TXE	CSIGN RXE	0	0	0	0	CSIGN MBS
R/W	R/W	R/W	R	R	R	R	R/W

Table 21-9 CSIGNCTL0 Register Contents

Bit Position	Bit Name	Function
7	CSIGNPWR	Controls operation clock: 0: Stop operation clock 1: Provide operation clock Clearing CSIGNPWR to 0 resets the internal circuits, stops operation, and sets the CSIG to standby state. No clock is provided to internal circuits. If CSIGNPWR is cleared during communication, ongoing communication is aborted. A restart of the communication is then required.
6	CSIGNTXE	Enables/disables transmission: 0: Transmission disabled 1: Transmission enabled
5	CSIGNRXE	Enables/disables reception: 0: Reception disabled 1: Reception enabled
0	CSIGNMBS	Be sure to set this bit to 1 (the initial value is 0).

-
- Caution 1. Do not modify CSIGNRXE or CSIGNTXE while CSIGNPWR = 0. However, both bits can be modified in the same write operation when setting CSIGNPWR = 1.
- Caution 2. Do not modify CSIGNRXE or CSIGNTXE while a data transmission is pending or ongoing, i.e. if CSIGNSTR0.CSIGNTSF = 1.
-

(2) CSIGNCTL1 - CSIG Control Register 1

This register specifies the interrupt timing and the interrupt delay mode. It enables/disables extended data length control, data consistency check, loop-back mode, and handshake function.

Access This register can be read/written in 32-bit units.

Address <CSIGN_base0> + 10_H

Initial value 0000 0000_H

This register is initialized by a reset from any source.

31	30	29	28	27	26	25	24	23	22	21	20	19	18	17	16
0	0	0	0	0	0	0	0	0	0	0	0	0	0	CSIGNCKR	CSIGNSLIT
R	R	R	R	R	R	R	R	R	R	R	R	R	R	R/W	R/W
15	14	13	12	11	10	9	8	7	6	5	4	3	2	1	0
0	0	0	0	0	0	0	0	CSIGNEDLE	0	CSIGNDCS	0	CSIGNLBM	CSIGNSIT	CSIGNHSE	0
R	R	R	R	R	R	R	R	R/W	R	R/W	R	R/W	R/W	R/W	R

Caution Changing the contents of this register is only permitted when CSIGNCTL0.CSIGNPWR = 0.

Table 21-10 CSIGNCTL1 Register Contents (1/2)

Bit Position	Bit Name	Function
17	CSIGNCKR	Selects the phase of the CSIGNTSCK clock signal. 0: Default level of CSIGNTSCK is high 1: Default level of CSIGNTSCK is low For the setting example, refer to the CSIGNDAP bit in Table 21-15, CSIGNCFG0 Register Contents.
16	CSIGNSLIT	Selects the timing of interrupt CSIGNTIC: 0: Normal interrupt timing (interrupt is generated after the transfer) 1: Interrupt is generated when CSIGNTX0W or CSIGNTX0H is free for further data. For details, refer to Section 21.3.8 (1), CSIGNTIC (Communication Interrupt).
7	CSIGNEDLE	Enables/disables extended data length (EDL) mode: 0: Extended data length mode disabled 1: Extended data length mode enabled For details, refer to Section 21.3.5 (2), Data Length Greater than 16 Bits..
5	CSIGNDCS	Enables/disables data consistency check: 0: Data consistency check disabled 1: Data consistency check enabled For details, refer to Section 21.3.11 (1), Data Consistency Check.

Table 21-10 CSIGNCTL1 Register Contents (2/2)

Bit Position	Bit Name	Function
3	CSIGNLBM	Controls loop-back mode (LBM): 0: Loop-back mode deactivated 1: Loop-back mode activated For details, refer to Section 21.3.10, Loop-Back Mode. Caution: Set the bit to 0 in slave mode.
2	CSIGNSIT	Selects interrupt delay mode: 0: No delay 1: Half clock delay for all interrupts This bit is only valid in master mode. In slave mode, no delay is generated. For details, refer to Section 21.3.8, CSIG Interrupts.
1	CSIGNHSE	Enables/disables handshake mode: 0: Handshake function disabled 1: Handshake function enabled For details, refer to Section 21.3.9, Handshake Function.

(3) CSIGNCTL2 - CSIG Control Register 2

This register selects the communication clock.

Access This register can be read/written in 16-bit units.

Address <CSIGN_base0> + 14_H

Initial value E000_H

This register is initialized by a reset from any source.

15	14	13	12	11	10	9	8	7	6	5	4	3	2	1	0
CSIGN PRS[2:0]			0	CSIGN BRS[11:0]											
R/W	R/W	R/W	R	R/W	R/W	R/W	R/W	R/W	R/W	R/W	R/W	R/W	R/W	R/W	R/W

Caution Changing the contents of this register is only permitted when CSIGNCTL0.CSIGNPWR = 0.

Table 21-11 CSIGNCTL2 Register Contents

Bit Position	Bit Name	Function																																				
15 to 13	CSIGNPRS [2:0]	Selects the value of the prescaler: <table border="1" style="margin-top: 10px;"> <thead> <tr> <th>CSIGN PRS2</th> <th>CSIGN PRS1</th> <th>CSIGN PRS0</th> <th>Prescaler Output (PRSOUT)</th> </tr> </thead> <tbody> <tr><td>0</td><td>0</td><td>0</td><td>PCLK (master mode)</td></tr> <tr><td>0</td><td>0</td><td>1</td><td>PCLK/2 (master mode)</td></tr> <tr><td>0</td><td>1</td><td>0</td><td>PCLK/4 (master mode)</td></tr> <tr><td>0</td><td>1</td><td>1</td><td>PCLK/8 (master mode)</td></tr> <tr><td>1</td><td>0</td><td>0</td><td>PCLK/16 (master mode)</td></tr> <tr><td>1</td><td>0</td><td>1</td><td>PCLK/32 (master mode)</td></tr> <tr><td>1</td><td>1</td><td>0</td><td>PCLK/64 (master mode)</td></tr> <tr><td>1</td><td>1</td><td>1</td><td>External clock via CSIGNTSCK (slave mode)</td></tr> </tbody> </table>	CSIGN PRS2	CSIGN PRS1	CSIGN PRS0	Prescaler Output (PRSOUT)	0	0	0	PCLK (master mode)	0	0	1	PCLK/2 (master mode)	0	1	0	PCLK/4 (master mode)	0	1	1	PCLK/8 (master mode)	1	0	0	PCLK/16 (master mode)	1	0	1	PCLK/32 (master mode)	1	1	0	PCLK/64 (master mode)	1	1	1	External clock via CSIGNTSCK (slave mode)
CSIGN PRS2	CSIGN PRS1	CSIGN PRS0	Prescaler Output (PRSOUT)																																			
0	0	0	PCLK (master mode)																																			
0	0	1	PCLK/2 (master mode)																																			
0	1	0	PCLK/4 (master mode)																																			
0	1	1	PCLK/8 (master mode)																																			
1	0	0	PCLK/16 (master mode)																																			
1	0	1	PCLK/32 (master mode)																																			
1	1	0	PCLK/64 (master mode)																																			
1	1	1	External clock via CSIGNTSCK (slave mode)																																			
11 to 0	CSIGNBRS [11:0]	Selects the baud rate: <table border="1" style="margin-top: 10px;"> <thead> <tr> <th>CSIGNBRS[11:0]</th> <th>Baud Rate at CSIGNTSCK</th> </tr> </thead> <tbody> <tr><td>0</td><td>BRG is stopped</td></tr> <tr><td>1</td><td>PCLK/(2^m × 1 × 2)</td></tr> <tr><td>2</td><td>PCLK/(2^m × 2 × 2)</td></tr> <tr><td>3</td><td>PCLK/(2^m × 3 × 2)</td></tr> <tr><td>4</td><td>PCLK/(2^m × 4 × 2)</td></tr> <tr><td>...</td><td>...</td></tr> <tr><td>4095</td><td>PCLK/(2^m × 4095 × 2)</td></tr> </tbody> </table> <p>m = CSIGNPRS[2:0] = 0 to 6 The setting is enabled in master mode.</p>	CSIGNBRS[11:0]	Baud Rate at CSIGNTSCK	0	BRG is stopped	1	PCLK/(2 ^m × 1 × 2)	2	PCLK/(2 ^m × 2 × 2)	3	PCLK/(2 ^m × 3 × 2)	4	PCLK/(2 ^m × 4 × 2)	4095	PCLK/(2 ^m × 4095 × 2)																				
CSIGNBRS[11:0]	Baud Rate at CSIGNTSCK																																					
0	BRG is stopped																																					
1	PCLK/(2 ^m × 1 × 2)																																					
2	PCLK/(2 ^m × 2 × 2)																																					
3	PCLK/(2 ^m × 3 × 2)																																					
4	PCLK/(2 ^m × 4 × 2)																																					
...	...																																					
4095	PCLK/(2 ^m × 4095 × 2)																																					

(4) CSIGNSTR0 - CSIG Status Register 0

This register indicates the status of the CSIG.

Access This register can be read in 32-bit units.

However, the CSIGNDCE, CSIGNPE and CSIGNOVE bits are writable when CSIGNCTL0.PWR is 0.

Address <CSIGN_base1> + 04_H

Initial value 0000 0010_H

This register is initialized by a reset from any source.

31	30	29	28	27	26	25	24	23	22	21	20	19	18	17	16
0	0	0	0	0	0	0	0	0	0	0	0	0	0	0	0
R	R	R	R	R	R	R	R	R	R	R	R	R	R	R	R
15	14	13	12	11	10	9	8	7	6	5	4	3	2	1	0
0	0	0	0	0	0	0	0	CSIGN TSF	0	0	1	CSIGN DCE	0	CSIGN PE	CSIGN OVE
R	R	R	R	R	R	R	R	R	R	R	R	R	R	R	R

Table 21-12 CSIGNSTR0 Register Contents (1/2)

Bit Position	Bit Name	Function																		
7	CSIGNTSF	Transfer status flag: 0: Idle state 1: Transmission is in progress or being prepared Conditions for setting and clearing the bit are as follows: <table border="1" style="margin-top: 10px;"> <thead> <tr> <th>Master Mode</th> <th>Set by</th> <th>Cleared by</th> </tr> </thead> <tbody> <tr> <td>Transmit-only mode</td> <td rowspan="2">Writing to the CSIGNTX0W or CSIGNTX0H register</td> <td rowspan="3">Within 0.5 clock from the last edge of CSIGNTSCK</td> </tr> <tr> <td>Transmit/Receive mode</td> </tr> <tr> <td>Receive-only mode</td> <td>Reading from the CSIGNRX0 register</td> </tr> </tbody> </table> <table border="1" style="margin-top: 10px;"> <thead> <tr> <th>Slave Mode</th> <th>Set by</th> <th>Cleared by</th> </tr> </thead> <tbody> <tr> <td>Transmit-only mode</td> <td rowspan="2">Writing to the CSIGNTX0W or CSIGNTX0H register</td> <td rowspan="3">Within 0.5 clock from the last edge of CSIGNTSCK</td> </tr> <tr> <td>Transmit/Receive mode</td> </tr> <tr> <td>Receive-only mode</td> <td>Input clock on the CSIGNTSCK pin</td> </tr> </tbody> </table>	Master Mode	Set by	Cleared by	Transmit-only mode	Writing to the CSIGNTX0W or CSIGNTX0H register	Within 0.5 clock from the last edge of CSIGNTSCK	Transmit/Receive mode	Receive-only mode	Reading from the CSIGNRX0 register	Slave Mode	Set by	Cleared by	Transmit-only mode	Writing to the CSIGNTX0W or CSIGNTX0H register	Within 0.5 clock from the last edge of CSIGNTSCK	Transmit/Receive mode	Receive-only mode	Input clock on the CSIGNTSCK pin
Master Mode	Set by	Cleared by																		
Transmit-only mode	Writing to the CSIGNTX0W or CSIGNTX0H register	Within 0.5 clock from the last edge of CSIGNTSCK																		
Transmit/Receive mode																				
Receive-only mode	Reading from the CSIGNRX0 register																			
Slave Mode	Set by	Cleared by																		
Transmit-only mode	Writing to the CSIGNTX0W or CSIGNTX0H register	Within 0.5 clock from the last edge of CSIGNTSCK																		
Transmit/Receive mode																				
Receive-only mode	Input clock on the CSIGNTSCK pin																			

Table 21-12 CSIGNSTR0 Register Contents (2/2)

Bit Position	Bit Name	Function
3	CSIGNDCE	<p>Data consistency check error flag:</p> <p>0: No data consistency error detected 1: Data consistency error detected</p> <p>This bit is cleared by writing 1 to CSIGNSTCR0.CSIGNDCEC. This bit is writable when CSIGNCTL0.CSIGNPWR is 0. This bit is initialized when CSIGNCTL0.CSIGNPWR changes from 0 to 1 or from 1 to 0.</p> <p>When setting to 1 due to data consistency error detection and clearing to 0 by CSIGNSTCR0.CSIGNDCEC occur simultaneously, setting to 1 due to data consistency error detection takes precedence over clearing.</p>
1	CSIGNPE	<p>Parity error flag:</p> <p>0: No parity error detected 1: Parity error detected</p> <p>This bit is cleared by writing 1 to CSIGNSTCR0.CSIGNPEC. This bit is writable when CSIGNCTL0.CSIGNPWR is 0. This bit is initialized when CSIGNCTL0.CSIGNPWR changes from 0 to 1 or from 1 to 0.</p> <p>When setting to 1 due to parity error detection and clearing to 0 by writing to CSIGNSTCR0.CSIGNPEC occur simultaneously, setting to 1 due to parity error detection takes precedence over clearing.</p>
0	CSIGNOVE	<p>Overrun error flag:</p> <p>0: No overrun error detected 1: Overrun error detected</p> <p>This bit is cleared by writing 1 to CSIGNSTCR0.CSIGNOVEC. This bit is writable when CSIGNCTL0.CSIGNPWR is 0. This bit is initialized when CSIGNCTL0.CSIGNPWR changes from 0 to 1 or from 1 to 0.</p> <p>When setting to 1 due to overrun error detection and clearing to 0 by writing to CSIGNSTCR0.CSIGNOVEC occur simultaneously, setting to 1 due to overrun error detection takes precedence over clearing.</p>

(5) CSIGNSTCR0 - CSIG Status Clear Register 0

This register clears the status flags of the CSIGNSTR0 status register.

Access This register can be read/written in 16-bit units. The value is always read as 0000_H.

Address <CSIGN_base1> + 08_H

Initial value 0000_H

This register is initialized by a reset from any source.

15	14	13	12	11	10	9	8	7	6	5	4	3	2	1	0
0	0	0	0	0	0	0	0	0	0	0	0	CSIGN DCEC	0	CSIGN PEC	CSIGN OVEC
R	R	R	R	R	R	R	R	R	R	R	R	W	R	W	W

Table 21-13 CSIGNSTCR0 Register Contents

Bit Position	Bit Name	Function
3	CSIGNDCEC	Controls the operation of clearing the data consistency check error flag (CSIGNSTR0.CSIGNDCE) 0: No operation. Read value is always 0. 1: Clear data consistency error flag (CSIGNSTR0.CSIGNDCE).
1	CSIGNPEC	Controls the operation of clearing the parity error flag (CSIGNSTR0.CSIGNPE). 0: No operation. Read value is always 0. 1: Clear parity error flag (CSIGNSTR0.CSIGNPE).
0	CSIGNOVEC	Controls the operation of clearing the overrun error flag (CSIGNSTR0.CSIGNOVE). 0: No operation. Read value is always 0. 1: Clear overrun error flag (CSIGNSTR0.CSIGNOVE).

(6) CSIGNBCTL0 - CSIG Receive-Only Mode Control Register 0

This register enables/disables the data transfer in receive-only mode.

Access This register can be read/written in 1-bit and 8-bit units.

Address <CSIGN_base1> + 80_H

Initial value 01_H

This register is initialized by a reset from any source.

7	6	5	4	3	2	1	0
0	0	0	0	0	0	0	CSIGN SCE
R	R	R	R	R	R	R	R/W

Table 21-14 CSIGNBCTL0 Register Contents

Bit Position	Bit Name	Function
0	CSIGNSCE	Disables/enables next data reception start by reading CSIGNRX0: 0: Next reception disabled 1: Next reception enabled For details, refer to Section 21.3.4 (2), Receive-Only Mode.

Note Setting of the CSIGNSCE bit is ineffective in transmit-only and transmit/receive modes.

Caution To stop subsequent reception, the CSIGNSCE bit has to be controlled as follows.

- If CSIGNSLIT is 0, clear the bit before the last data reception (reading from the CSIGNRX0 register).
- If CSIGNSLIT is 1, clear the bit immediately after reception of all but the last of the data (reading from the CSIGNRX0 register) and at least one clock cycle of CSIGNTSCK before generation of the CSIGNTIR interrupt for completion of the last reception.

(7) CSIGNCFG0 - CSIG Configuration Register 0

This register configures the communication protocol - data length, parity, transfer direction, clock phase, and data phase.

Access This register can be read/written in 32-bit units.

Address <CSIGN_base0> + 1010_H

Initial value 0000 0000_H

This register is initialized by a reset from any source.

31	30	29	28	27	26	25	24	23	22	21	20	19	18	17	16
0	0	CSIGN PS[1:0]		CSIGN DLS[3:0]				0	0	0	0	0	CSIGN DIR	0	CSIGN DAP
R	R	R/W	R/W	R/W	R/W	R/W	R/W	R	R	R	R	R	R/W	R	R/W
15	14	13	12	11	10	9	8	7	6	5	4	3	2	1	0
0	0	0	0	0	0	0	0	0	0	0	0	0	0	0	0
R	R	R	R	R	R	R	R	R	R	R	R	R	R	R	R

Caution Changing the contents of this register is only permitted when CSIGNCTL0.CSIGNPWR = 0.

Table 21-15 CSIGNCFG0 Register Contents (1/2)

Bit Position	Bit Name	Function																				
29 to 28	CSIGNPS [1:0]	Specifies parity: <table border="1" data-bbox="584 360 1385 656"> <thead> <tr> <th>CSIGNPS1</th> <th>CSIGNPS0</th> <th>Transmission</th> <th>Reception</th> </tr> </thead> <tbody> <tr> <td>0</td> <td>0</td> <td>No parity transmitted</td> <td>No parity judged.</td> </tr> <tr> <td>0</td> <td>1</td> <td>Add parity bit fixed to 0</td> <td>Parity bit is received but not judged.</td> </tr> <tr> <td>1</td> <td>0</td> <td>Add odd parity</td> <td>Odd parity judged.</td> </tr> <tr> <td>1</td> <td>1</td> <td>Add even parity</td> <td>Even parity judged.</td> </tr> </tbody> </table>	CSIGNPS1	CSIGNPS0	Transmission	Reception	0	0	No parity transmitted	No parity judged.	0	1	Add parity bit fixed to 0	Parity bit is received but not judged.	1	0	Add odd parity	Odd parity judged.	1	1	Add even parity	Even parity judged.
CSIGNPS1	CSIGNPS0	Transmission	Reception																			
0	0	No parity transmitted	No parity judged.																			
0	1	Add parity bit fixed to 0	Parity bit is received but not judged.																			
1	0	Add odd parity	Odd parity judged.																			
1	1	Add even parity	Even parity judged.																			
27 to 24	CSIGNDLS [3:0]	Specifies data length: 0: Data length is 16 bits 1: Data length is 1 bit 2: Data length is 2 bits ... 15: Data length is 15 bits Caution: The extended data length (EDL) function has to be used to set data lengths from 1 to 6 bits (refer to Section 21.3.5 (2), Data Length Greater than 16 Bits. Transmitting twice consecutively with a data length of less than 7 bits is forbidden.																				
18	CSIGNDIR	Selects the orientation of transferred data: 0: Data is transmitted/received with MSB first 1: Data is transmitted/received with LSB first																				

Table 21-15 CSIGNCFG0 Register Contents (2/2)

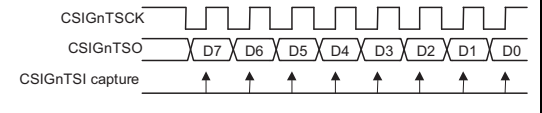
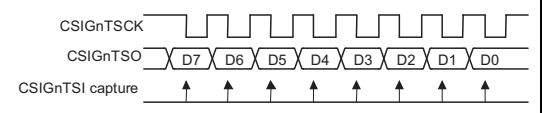
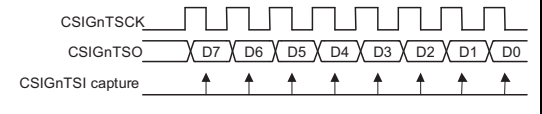
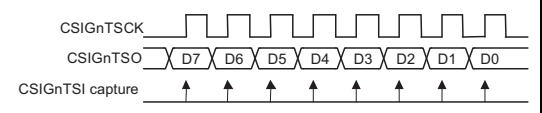
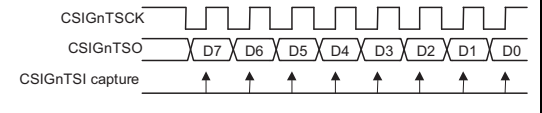
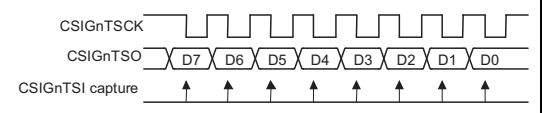
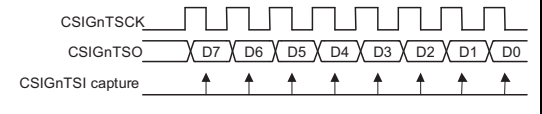
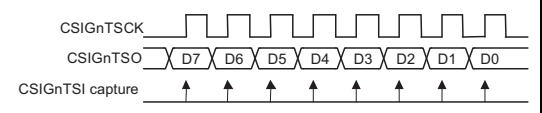
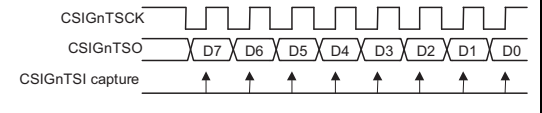
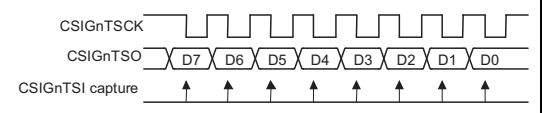
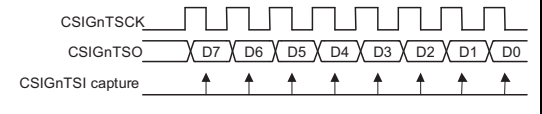
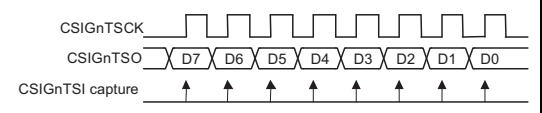
Bit Position	Bit Name	Function												
16	CSIGNDAP	<p>Data phase selection bit</p> <p>The timing of data transmission and reception according to the combination of CSIGNCTL1.CSIGNCKR and this bit is as follows.</p> <ul style="list-style-type: none"> CSIGNCTL1.CSIGNCKR = 0 <table border="1" data-bbox="707 495 1385 831"> <thead> <tr> <th>CSIGN DAP</th> <th>Clock and Data Phase Selection</th> </tr> </thead> <tbody> <tr> <td>0</td> <td>  </td> </tr> <tr> <td>1</td> <td>  </td> </tr> </tbody> </table> CSIGNCTL1.CSIGNCKR = 1 <table border="1" data-bbox="707 913 1385 1249"> <thead> <tr> <th>CSIGN DAP</th> <th>Clock and Data Phase Selection</th> </tr> </thead> <tbody> <tr> <td>0</td> <td>  </td> </tr> <tr> <td>1</td> <td>  </td> </tr> </tbody> </table> 	CSIGN DAP	Clock and Data Phase Selection	0		1		CSIGN DAP	Clock and Data Phase Selection	0		1	
CSIGN DAP	Clock and Data Phase Selection													
0														
1														
CSIGN DAP	Clock and Data Phase Selection													
0														
1														

(8) CSIGNTX0W - CSIG Transmission Register 0 for Word Access

This register stores the transmission data. It has to be used when the extended data length function is enabled (CSIGNCTL1.CSIGNEDLE = 1).

Access This register can be read/written in 32-bit units.

Address <CSIGN_base1> + 84_H

Initial value 0000 0000_H

This register is initialized by a reset from any source.

31	30	29	28	27	26	25	24	23	22	21	20	19	18	17	16
0	0	CSIGNEDL	0	0	0	0	0	0	0	0	0	0	0	0	0
R	R	R/W	R	R	R	R	R	R	R	R	R	R	R	R	R
15	14	13	12	11	10	9	8	7	6	5	4	3	2	1	0
CSIGNTX[15:0]															
R/W	R/W	R/W	R/W	R/W	R/W	R/W	R/W	R/W	R/W	R/W	R/W	R/W	R/W	R/W	R/W

Caution Writing to this register is forbidden when CSIGNCTL0.CSIGNTXE = 0 and CSIGNCTL0.CSIGNRXE = 0.

Table 21-16 CSIGNTX0W Register Contents

Bit Position	Bit Name	Function
29	CSIGNEDL	Specifies the extended data length configuration: 0: Normal operation 1: Extended data length activated The data is transmitted as 16-bit data. Caution: This bit can only be set if CSIGNCTL1.CSIGNEDLE = 1. It is automatically cleared if CSIGNCTL1.CSIGNEDLE is cleared.
15 to 0	CSIGNTX[15:0]	Data to be transmitted

(9) CSIGnTX0H - CSIG Transmission Register 0 for Half Word Access

This register stores the transmission data. It can be used when the extended data length function is disabled (CSIGnCTL1.CSIGnEDLE = 0).

Access This register can be read/written in 16-bit units.

Address <CSIGn_base1> + 88_H

Initial value 0000_H

This register is initialized by a reset from any source.

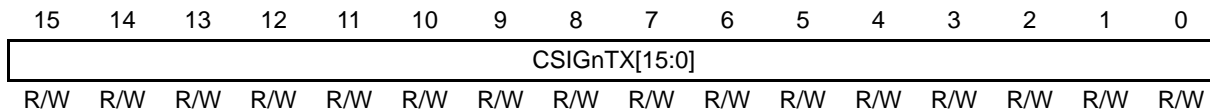

Caution Writing to this register is forbidden when CSIGnCTL0.CSIGnTXE = 0 and CSIGnCTL0.CSIGnRXE = 0.

Table 21-17 CSIGnTX0H Register Contents

Bit Position	Bit Name	Function
15 to 0	CSIGnTX [15:0]	Data to be transmitted

(10) CSIGNRX0 - CSIG reception register 0

This register stores the received data.

Access This register can be read in 16-bit units.

Address <CSIGN_base1> + 8C_H

Initial value 0000_H

This register is initialized by a reset from any source.

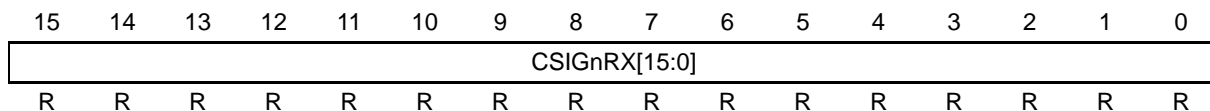

-
- Caution 1. This register is initialized when CSIGNCTL0.CSIGNPWR changes from 0 to 1 or from 1 to 0.
 - Caution 2. Reading from this register is forbidden when CSIGNCTL0.CSIGNTXE = 0 and CSIGNCTL0.CSIGNRXE = 0. Values read from the register while settings are as follows are undefined.
 - CSIGNPWR = 0, CSIGNTXE = 1, CSIGNRXE = 1
 - CSIGNPWR = 1, CSIGNTXE = 0, CSIGNRXE = 0
 - Caution 3. Reading from this register is possible when CSIGNCTL0.CSIGNPWR = 1
 - Caution 4. Writing to this register is possible when CSIGNCTL0.CSIGNPWR = 0.
-

Table 21-18 CSIGNRX0 Register Contents

Bit Position	Bit Name	Function
15 to 0	CSIGNRX [15:0]	Received data

21.5 Operating Procedure Example

A transmit/receive example in master mode is described in this section. The following instructions are based on the assumption that:

- Transmission data length is 8 bits (CSIGNCFG0.CSIGNDLS[3:0] = 1000_B)
- MSB is transmitted first (CSIGNCFG0.CSIGNDIR = 0)
- CSIGNnTIC interrupt is generated at the end of the transfer (CSIGNnCTL1.CSIGNSLIT = 0)
- Normal clock and data phase: CSIGNnCTL1.CSIGNCKR = 0, CSIGNCFG0.CSIGNDAP = 0
- The number of data packets is 10 (0 to 9)

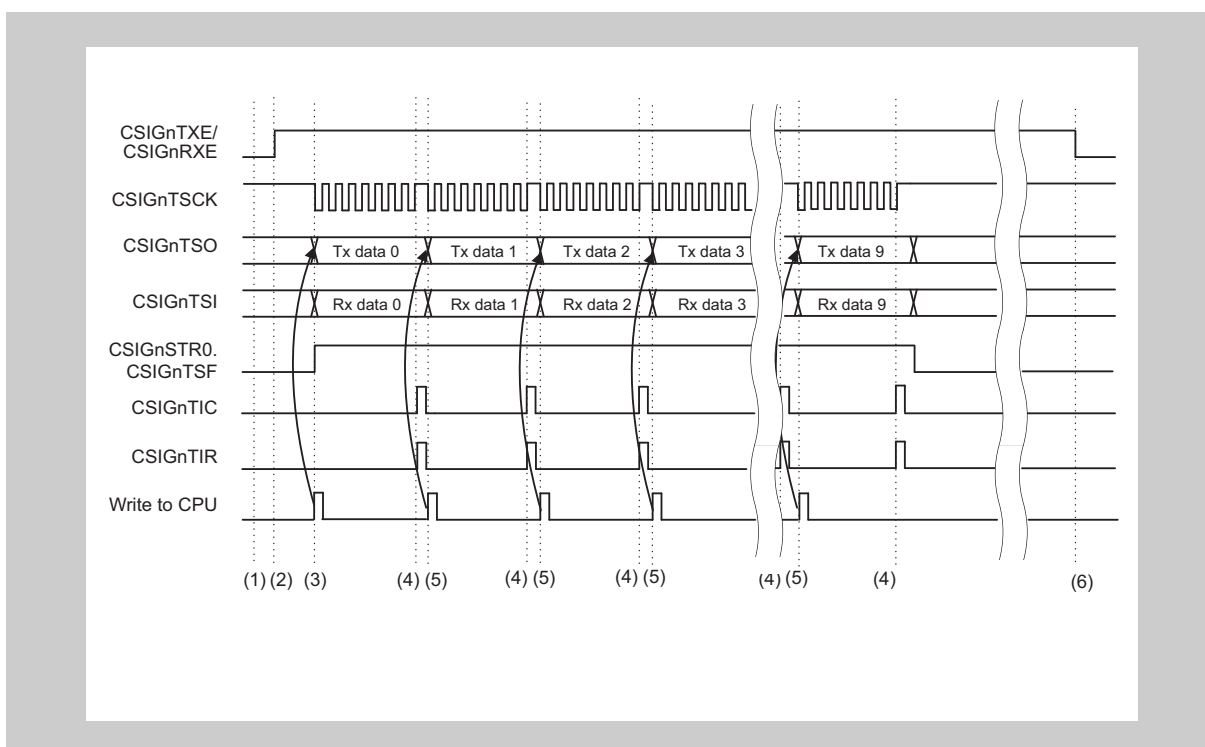

Figure 21-25 Communication in Master Mode

Procedure:

1. Configure each function in the CSIGNCTL1 register, communication speed in the CSIGNCTL2 register, and communication protocol in the CSIGNCFG0 register, respectively.
2. In the CSIGNCTL0 register, set bits CSIGNPWR = 1 (enabling the clock), CSIGNTXE = 1 (enabling transmission), and CSIGNRXE = 1 (enabling reception). The data output pin CSIGNTSO is now enabled.
3. Write the first packet of data to be sent to the transmission register (CSIGNTX0W or CSIGNTX0H). Transmission starts automatically.
4. After every packet that has been transmitted, the interrupts CSIGNTIC and CSIGNTIR are generated. CSIGNTIC indicates that the next packet can be written to CSIGNTX0W or CSIGNTX0H. CSIGNTIR indicates that the reception register CSIGNRX0 must be read.

In this example, CPU write and DMA write are equivalent.

5. Write the next data to CSIGNTX0W or CSIGNTX0H.
6. No more write action is required after completion of packet 9.
7. To finally disable the transmit/receive operation, clear CSIGNCTL0.CSIGNTXE and CSIGNCTL0.CSIGNRXE.

Section 22 Synchronous/Asynchronous Serial Interface H (UARTH)

22.1 UARTHn Features

Instances This product has 2 instances of the synchronous/asynchronous serial interface H (UARTHn).

Table 22-1 Instances of UARTHn

Synchronous/Asynchronous Serial Interface H	
Instances	2
Name	UARTHn

Instances index n Throughout this section, the instance of a synchronous/asynchronous serial interface H is identified by the index "n" (n = 0, 1), for example, URTHnCTL0 for the UARTHn control register 0.

Register addresses All UARTHn register addresses are given as offsets from the individual base addresses, <URTHn_base0> and <URTHn_base1>.

The <URTHn_base0> and <URTHn_base1> addresses of each UARTHn are listed in the following table.

Table 22-2 UARTHn Register Base Addresses <URTHn_base0> and <URTHn_base1>

UARTHn	<URTHn_base0> Address	<URTHn_base1> Address
UARTH0	FF5C0000 _H	FFFFEA00 _H
UARTH1	FF5D0000 _H	FFFFEB00 _H

Clock supply A single clock signal is input to each UARTHn as follows.

Table 22-3 UARTHn Clock Supply

UARTHn	UARTHn Clock	Connected to
UARTH0	PCLK	Clock controller
UARTH1		

I/O signals The I/O signals of the UARTHn are listed in the table below.

Table 22-4 UARTH I/O Signals

UARTHn Signals	Function	Connected to
URTHnTXD	Transmit data output	Port URTHnTXD
URTHnRXD	Receive data input	Port URTHnRXD
URTHnSC	Synchronizing clock input/output	Port URTHnSC
URTHnRTS	Handshake signal output	Port URTHnRTS
URTHnCTS	Handshake signal input	Port URTHnCTS

Interrupts Interrupts of UARTHn are listed in the table below.

Table 22-5 UARTHn Interrupts

UARTHn Signals	Function	Connected to
URTHnTIT	Transmission interrupt	Interrupt controller INTURTHnIT DMA
URTHnTIR	Reception interrupt	Interrupt controller INTURTHnIR DMA
URTHnTIS	Status interrupt	Interrupt controller INTURTHnIS DMA

Port Use UARTHn pins from the groups listed below.

Table 22-6 Port Groups for UARTHn

UARTHn Channel	Pin Name	Group		
		1	2	3
UARTH0	URTH0SC	P0_2	P1_9	P5_2
	URTH0TXD	P0_1	P1_8	P5_1
	URTH0RXD	P0_0	P1_7	P5_0
	URTH0CTS	P0_3	—	P5_3
	URTH0RTS	—	—	—
UARTH1	URTH1SC	P2_0	—	—
	URTH1TXD	P3_1	P4_1	—
	URTH1RXD	P3_0	P4_0	—
	URTH1CTS	P4_3	—	—
	URTH1RTS	P4_4	—	—

22.2 Features

- Synchronous and asynchronous mode selectable
- Full-duplex communication:
 - Internal UARTHn receive data register n (URTHnRX)
 - Internal UARTHn transmit data register n (URTHnTX)
- 2-pin configuration:
 - URTHnTXD: Transmit data output pin
 - URTHnRXD: Receive data input pin
- Reception error and status output function
 - Parity error
 - Framing error
 - Overrun error
 - Data consistency error
- Interrupt sources: 3
 - Transmission interrupt URTHnTIT
 - Reception interrupt URTHnTIR
 - Status interrupt URTHnTIS
- Character length: 7, 8, or 9 bits (with the extension bit)
- Parity function: odd, even, 0, or none
- Transmission stop bit(s): 1 or 2
- MSB-/LSB-first transfer selectable
- Inversion of data for transmission and received data is available
- 13 to 20 bits selectable for the BF (break field) in the LIN (local interconnect network) communication format
 - Recognition of 11 bits or more possible for BF reception in LIN communication format
 - BF reception flag provided
- BF reception can be detected during data communication.
- Bus monitor function to keep data consistency of the transmit data
- Handshake mode (URTHnCTS pin, URTHnRTS pin: active level selectable)
- Transmission of 1 frame or 2 frames in succession
- Extension bit detection interrupt setting is available.
- Noise canceling function (for the URTHnRXD, URTHnCTS, and URTHnSC pins)
- Delayed sampling mode (in clock-synchronous mode)
- Baud-rate detection in operation as a slave device for LIN communications

22.3 Configuration

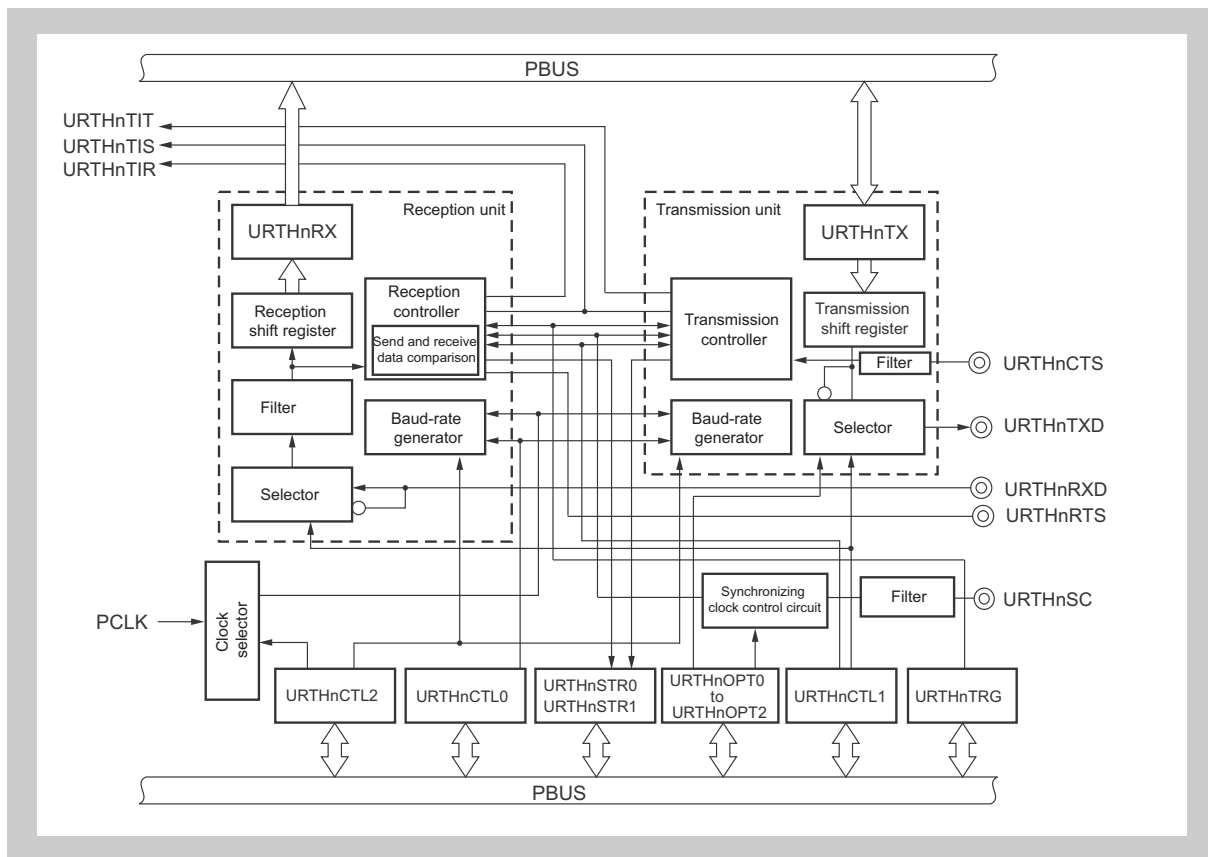

Figure 22-1 Block Diagram of Synchronous/Asynchronous Serial Interface (UARTHn)

22.4 UARTHn Registers

The UARTHn is controlled and operated by means of the following registers.

Table 22-7 UARTHn Registers

Register Function	Name	Address
Control register 0	URTHnCTL0	<URTHn_base1> + 00 _H
Control register 1	URTHnCTL1	<URTHn_base0> + 40 _H
Control register 2	URTHnCTL2	<URTHn_base0> + 44 _H
Trigger register	URTHnTRG	<URTHn_base1> + 0C _H
Status register 0	URTHnSTR0	<URTHn_base1> + 10 _H
Status register 1	URTHnSTR1	<URTHn_base1> + 14 _H
Status clear register	URTHnSTC	<URTHn_base1> + 18 _H
Option register 0	URTHnOPT0	<URTHn_base0> + 48 _H
Option register 1	URTHnOPT1	<URTHn_base1> + 04 _H
Option register 2	URTHnOPT2	<URTHn_base1> + 08 _H
Receive data register	URTHnRX	<URTHn_base1> + 1C _H
Receive data register HL	URTHnRXHL	<URTHn_base1> + 20 _H
Extension bit receive data register	URTHnERX	<URTHn_base1> + 24 _H
Extension bit receive word data register	URTHnERXW	<URTHn_base1> + 28 _H
Transmit data register	URTHnTX	<URTHn_base1> + 2C _H
Transmit data register HL	URTHnTXHL	<URTHn_base1> + 30 _H
Extension bit transmit data register	URTHnETX	<URTHn_base1> + 34 _H
Extension bit transmit word data register	URTHnETXW	<URTHn_base1> + 38 _H
LIN communications slave operation baud-rate detection register 0	IC0REG0	FFFFFFE0 _H

<URTHn_base> For the base addresses of the UARTHn registers, i.e. <URTHn_base0> and <URTHn_base1>, refer to Table 22-2, UARTHn Register Base Addresses <URTHn_base0> and <URTHn_base1>.

(1) URTHnCTL0 – UARTHn Control Register 0

This register controls the basic serial-transfer operations of the UARTHn.

Access This register can be read/written in 8- or 1-bit units.

Address <URTHn_base1> + 00_H

Initial value 00_H

This register is initialized by a reset from any source.

7	6	5	4	3	2	1	0
URTHn PW	URTHn TXE	URTHn RXE	0	0	0	0	URTHn SLDC
R/W	R/W	R/W	R	R	R	R	R/W

Table 22-8 URTHnCTL0 Register Contents

Bit Position	Bit Name	Function
7	URTHnPW	UARTHn enable 0: Disable UARTHn operation 1: Enable UARTHn operation Changing this bit initializes all transmission and reception units.
6	URTHnTXE	Transmission operation enable 0: Disable transmission operation 1: Enable transmission operation <ul style="list-style-type: none"> To start transmission, set URTHnPW to 1 and then set URTHnTXE to 1. To stop transmission, clear URTHnTXE to 0 and then URTHnPW to 0. Alternatively, clear URTHnPW and URTHnTXE simultaneously. To initialize the transmission unit, clear URTHnTXE to 0, wait for 2 cycles of the PRSCLK clock, and then set URTHnTXE to 1 again.
5	URTHnRXE	Reception operation enable 0: Disable reception operation 1: Enable reception operation <ul style="list-style-type: none"> To enable reception, set URTHnPW to 1 and then set URTHnRXE to 1. To disable reception, clear URTHnRXE to 0, or clear URTHnPW and URTHnRXE simultaneously. To initialize the reception unit, clear URTHnRXE to 0, wait for 2 cycles of the PRSCLK clock, and then set URTHnRXE to 1 again. Setting URTHnRXE to 1 enables reception after 2 cycles of the PRSCLK clock have elapsed. 4 cycles of the base clock elapse from setting of URTHnRXE to 1 until the detection of edges on the URTHnRXD pin is enabled.
0	URTHnSLDC	Data consistency check enable/disable 0: Disable data consistency check 1: Enable data consistency check This bit selects the handling of checking for data consistency errors in data for transmission. When this bit is set to 1, the transmitted and received data are compared. If the two do not match, the URTHnSTR1.URTHnDCE flag is set to 1 and a status interrupt request (URTHnTIS) is issued. This bit is for access only when transmission is to be started. Consequently, if the value of this bit is changed during processing for transmission, the processing for transmission will continue with the same value as was set at the start of processing.

Caution 1. If UARTHn is in the following states:

- reception and transmission are enabled (URTHnPW = URTHnRXE = URTHnTXE = 1),
- data consistency checking is enabled (URTHnSLDC = 1), and
- transmission is ongoing or completed

Transmission shall be disabled while enabling of reception is maintained; in this case, follow the procedure below.

- Check that transmission has not been executed (URTHnSTR0.URTHnSSBT = URTHnSTR0.URTHnSST = 0).
- Disable transmission by setting URTHnCTL0.URTHnTXE = 0.

This procedure is required because the data consistency error flag URTHnSTR1.URTHnDCE is cleared to 0 in response to clearing of URTHnTXE to 0. Thus a data consistency error would not be reported if it occurred in a case where transmission is disabled during transfer or after its completion.

Caution 2. If UARTHn is in the following states:

- reception and transmission are enabled (URTHnPW = URTHnRXE = URTHnTXE = 1),
- data consistency checking is enabled (URTHnSLDC = 1), and
- transmission is ongoing or completed

Reception shall be disabled while enabling of transmission is maintained; in this case, follow the procedure below.

- Check that transmission has not been executed (URTHnSTR0.URTHnSSBT = URTHnSTR0.URTHnSST = 0).
- Disable reception by setting URTHnCTL0.URTHnRXE = 0.

The reason for this procedure is that the data consistency error flag URTHnSTR1.URTHnDCE is cleared to 0 and becomes invalid in response to the clearing of URTHnRXE to 0. Following the procedure above leads to non-reporting of data consistency errors in data that have already been transmitted.

Caution 3. Don't start any data transmission if:

- data consistency checking is enabled (URTHnSLDC = 1),
- BF reception is enabled (URTHnSTR0.URTHnSSBR = 1), and
- detection of a BF during reception is not enabled (URTHnCTL1.URTHnSLBM = 0)

Under the above conditions, a data-consistency error will occur on completion of BF reception. The status interrupt signal (URTHnTIS) will be asserted and the completion of BF reception will not be reported (the URTHnSTR1.URTHnBSF flag remains 0). Consequently, the completion of BF reception will not be recognized.

(2) URTHnCTL1 – UARTHn Control Register 1

This register defines the data frame properties of the UARTHn serial data transfers.

Access This register can be read/written in 16-bit units.

Address <URTHn_base0> + 40_H

Initial value 5002_H

This register is initialized by a reset from any source.

15	14	13	12	11	10	9	8
URTHnSLBM	URTHnBLG[2:0]			0	0	0	URTHnCLG
R/W	R/W	R/W	R/W	R	R	R	R/W
7	6	5	4	3	2	1	0
URTHnSLP[1:0]		URTHnTDL	URTHnRDL	URTHnLPM	URTHnSLG	URTHnSLD	URTHnSLIT
R/W	R/W	R/W	R/W	R/W	R/W	R/W	R/W

Table 22-9 URTHnCTL1 Register Contents (1/3)

Bit Position	Bit Name	Function																																				
15	URTHnSLBM	BF reception mode selection 0: BF reception during data reception disabled. 1: BF reception during data reception enabled. <ul style="list-style-type: none"> Changing this bit is only allowed while reception is disabled (URTHnCTL0.URTHnPW = 0 or URTHnCTL0.URTHnRXE = 0). 																																				
14 to 12	URTHnBLG [2:0]	BF bit length during transmission <table border="1"> <thead> <tr> <th>URTHnBLG2</th><th>URTHnBLG1</th><th>URTHnBLG0</th><th>BF Length</th></tr> </thead> <tbody> <tr><td>1</td><td>0</td><td>1</td><td>13 bits</td></tr> <tr><td>1</td><td>1</td><td>0</td><td>14 bits</td></tr> <tr><td>1</td><td>1</td><td>1</td><td>15 bits</td></tr> <tr><td>0</td><td>0</td><td>0</td><td>16 bits</td></tr> <tr><td>0</td><td>0</td><td>1</td><td>17 bits</td></tr> <tr><td>0</td><td>1</td><td>0</td><td>18 bits</td></tr> <tr><td>0</td><td>1</td><td>1</td><td>19 bits</td></tr> <tr><td>1</td><td>0</td><td>0</td><td>20 bits</td></tr> </tbody> </table> <p>Changing these bits is only allowed while transmission is disabled (URTHnCTL0.URTHnPW = 0 or URTHnCTL0.URTHnTXE = 0).</p>	URTHnBLG2	URTHnBLG1	URTHnBLG0	BF Length	1	0	1	13 bits	1	1	0	14 bits	1	1	1	15 bits	0	0	0	16 bits	0	0	1	17 bits	0	1	0	18 bits	0	1	1	19 bits	1	0	0	20 bits
URTHnBLG2	URTHnBLG1	URTHnBLG0	BF Length																																			
1	0	1	13 bits																																			
1	1	0	14 bits																																			
1	1	1	15 bits																																			
0	0	0	16 bits																																			
0	0	1	17 bits																																			
0	1	0	18 bits																																			
0	1	1	19 bits																																			
1	0	0	20 bits																																			
8	URTHnCLG	Bit length of transmit/receive data 0: 7 bits 1: 8 bits or 9 bits (extension bit) <ul style="list-style-type: none"> When the transmission/reception is performed in the LIN format, set URTHnCTL1.URTHnCLG to 1. Changing this bit is only allowed while reception and transmission are disabled (URTHnCTL0.URTHnPW = 0 or URTHnCTL0.URTHnRXE = URTHnCTL0.URTHnTXE = 0). 																																				

Table 22-9 URTHnCTL1 Register Contents (2/3)

Bit Position	Bit Name	Function																						
7, 6	URTHnSLP [1:0]	<p>Parity bit selection</p> <table border="1"> <thead> <tr> <th rowspan="2">URTHnSLP1</th> <th rowspan="2">URTHnSLP0</th> <th colspan="2">Operation</th> </tr> <tr> <th>Transmission</th> <th>Reception</th> </tr> </thead> <tbody> <tr> <td>0</td> <td>0</td> <td>Output without parity bit</td> <td>Reception with no parity judgment</td> </tr> <tr> <td>0</td> <td>1</td> <td>Parity bit output is for zero parity (the setting is fixed to 0).</td> <td>No parity judgment</td> </tr> <tr> <td>1</td> <td>0</td> <td>Output with odd parity</td> <td>Judged as odd parity</td> </tr> <tr> <td>1</td> <td>1</td> <td>Output with even parity</td> <td>Judged as even parity</td> </tr> </tbody> </table> <ul style="list-style-type: none"> If "Reception with no parity judgment" is selected during reception, a parity check is not performed. Consequently, the URTHnSTR1.URTHnPE bit will not be set, so an error interrupt will not be output. When the transmission/reception is performed in the LIN format, set URTHnSLP[1:0] to 00_B. Changing these bits is only allowed while reception and transmission are disabled (URTHnCTL0.URTHnPW = 0 or URTHnCTL0.URTHnRXE = URTHnCTL0.URTHnTXE = 0). 	URTHnSLP1	URTHnSLP0	Operation		Transmission	Reception	0	0	Output without parity bit	Reception with no parity judgment	0	1	Parity bit output is for zero parity (the setting is fixed to 0).	No parity judgment	1	0	Output with odd parity	Judged as odd parity	1	1	Output with even parity	Judged as even parity
URTHnSLP1	URTHnSLP0	Operation																						
		Transmission	Reception																					
0	0	Output without parity bit	Reception with no parity judgment																					
0	1	Parity bit output is for zero parity (the setting is fixed to 0).	No parity judgment																					
1	0	Output with odd parity	Judged as odd parity																					
1	1	Output with even parity	Judged as even parity																					
5	URTHnTDL	<p>Transmit data level control</p> <p>0: No inverted output of transmit data 1: Inverted output of transmit data</p> <ul style="list-style-type: none"> This bit can be used to invert the levels output on the URTHnTXD pin. Changing the bit inverts the URTHnTXD output level immediately, regardless of the values of URTHnCTL0.URTHnPW and URTHnCTL0.URTHnTXE. Therefore, if URTHnTDL is set to 1 while operations are disabled, the URTHnTXD outputs low level. Changing this bit is only allowed while transmission is disabled (URTHnCTL0.URTHnPW = 0 or URTHnCTL0.URTHnTXE = 0). 																						
4	URTHnRDL	<p>Received data level control</p> <p>0: No inverted input of received data 1: Inverted input of received data</p> <ul style="list-style-type: none"> The input level of the URTHnRXD pin can be inverted using this bit. It inverts the URTHnRXD input level immediately, regardless of the values of URTHnCTL0.URTHnPW and URTHnCTL0.URTHnRXE. Therefore, if URTHnRDL is set to 1 while the operations are disabled, the URTHnRXD inputs low level. Changing this bit is only allowed while reception is disabled (URTHnCTL0.URTHnPW = 0 or URTHnCTL0.URTHnRXE = 0). 																						
3	URTHnLPM	<p>Loop back mode control</p> <p>0: Loop back of transmit data disabled 1: Loop back of transmit data enabled</p> <ul style="list-style-type: none"> This bit can be used to connect the URTHnTXD output to the URTHnRXD input. When this is done, the URTHnTXD output is fixed to "H" if URTHn0TDL = 0 and to "L" if URTHn0TDL = 1. If URTHnLPM = 1, disable handshake mode (URTHnOPT0.URTHnHS = 0). Changing this bit is only allowed while UARTHn operation is disabled (URTHnCTL0.URTHnPW = 0). 																						

Table 22-9 URTHnCTL1 Register Contents (3/3)

Bit Position	Bit Name	Function
2	URTHnSLG	<p>Stop bit number selection for transmit data</p> <p>0: 1 bit 1: 2 bits</p> <ul style="list-style-type: none"> The stop bit length during data or BF reception is always handled as "1". To use this register with data consistency checking enabled (URTHnCTL0.URTHnSLDC = 1) during slave operation, set URTHnSLG = 1. Changing this bit is only allowed while transmission is disabled (URTHnCTL0.URTHnPW = 0 or URTHnCTL0.URTHnTXE = 0).
1	URTHnSLD	<p>Transfer direction selection</p> <p>0: MSB-first transfer 1: LSB-first transfer</p> <ul style="list-style-type: none"> When the transmission/reception is performed in the LIN format, set URTHnSLD to 1. Changing this bit is only allowed while transmission and reception are disabled (URTHnCTL0.URTHnPW = 0 or URTHnCTL0.URTHnRXE, URTHnCTL0.URTHnTXE = 0).
0	URTHnSLIT	<p>Transmission interrupt request (URTHnTIT) timing selection</p> <p>0: URTHnTIT is generated when transmission starts after the data for transmission have been stored in the transmission shift register. 1: URTHnTIT is generated at transmission completion.</p> <ul style="list-style-type: none"> Changing this bit is only allowed while transmission is disabled (URTHnCTL0.URTHnPW = 0 or URTHnCTL0.URTHnTXE = 0).

(3) URTHnCTL2 – UARTHn Control Register 2

This register defines the baud rate for serial data transfer by UARTHn.

Access This register can be read/written in 16-bit units.

Address <URTHn_base0> + 44_H

Initial value EFFF_H

This register is initialized by a reset from any source.

15	14	13	12	11	10	9	8
URTHnPRS[2:0]			0	URTHnBRS[11:8]			
R/W	R/W	R/W	R	R/W	R/W	R/W	R/W
7	6	5	4	3	2	1	0
URTHnBRS[7:0]							
R/W	R/W	R/W	R/W	R/W	R/W	R/W	R/W

Table 22-10 URTHnCTL2 Register Contents

Bit Position	Bit Name	Function																												
15 to 13	URTHnPRS [2:0]	Prescaler clock (PRCLK) division value 0: PRCLK = PCLK/2 ⁰ 1: PRCLK = PCLK/2 ¹ 2: PRCLK = PCLK/2 ² 3: PRCLK = PCLK/2 ³ 4: PRCLK = PCLK/2 ⁴ 5: PRCLK = PCLK/2 ⁵ 6: PRCLK = PCLK/2 ⁶ 7: PRCLK = PCLK/2 ⁷																												
11 to 0	URTHnBRS [11:0]	Baud-rate clock (BRCLK) division value <table border="1" style="width: 100%; border-collapse: collapse;"> <thead> <tr> <th style="text-align: left;">URTHn BRS[11:0]</th> <th style="text-align: left;">Transmit/Receive BRCLK</th> <th style="text-align: left;">BF Receive Clock</th> </tr> </thead> <tbody> <tr> <td>000_H</td> <td>PRCLK/(2 × 2)</td> <td>PRCLK/2</td> </tr> <tr> <td>001_H</td> <td rowspan="3"></td> <td rowspan="3"></td> </tr> <tr> <td>002_H</td> </tr> <tr> <td>003_H</td> <td>PRCLK/(2 × 3)</td> <td>PRCLK/3</td> </tr> <tr> <td>004_H</td> <td>PRCLK/(2 × 4)</td> <td>PRCLK/4</td> </tr> <tr> <td>005_H</td> <td>PRCLK/(2 × 5)</td> <td>PRCLK/5</td> </tr> <tr> <td>...</td> <td>PRCLK/(2 × URTHnBRS[11:0])</td> <td>PRCLK/URTHnBRS[11:0]</td> </tr> <tr> <td>FFE_H</td> <td>PRCLK/(2 × 4094)</td> <td>PRCLK/4094</td> </tr> <tr> <td>FFF_H</td> <td>PRCLK/(2 × 4095)</td> <td>PRCLK/4095</td> </tr> </tbody> </table>	URTHn BRS[11:0]	Transmit/Receive BRCLK	BF Receive Clock	000 _H	PRCLK/(2 × 2)	PRCLK/2	001 _H			002 _H	003 _H	PRCLK/(2 × 3)	PRCLK/3	004 _H	PRCLK/(2 × 4)	PRCLK/4	005 _H	PRCLK/(2 × 5)	PRCLK/5	...	PRCLK/(2 × URTHnBRS[11:0])	PRCLK/URTHnBRS[11:0]	FFE _H	PRCLK/(2 × 4094)	PRCLK/4094	FFF _H	PRCLK/(2 × 4095)	PRCLK/4095
URTHn BRS[11:0]	Transmit/Receive BRCLK	BF Receive Clock																												
000 _H	PRCLK/(2 × 2)	PRCLK/2																												
001 _H																														
002 _H																														
003 _H			PRCLK/(2 × 3)	PRCLK/3																										
004 _H	PRCLK/(2 × 4)	PRCLK/4																												
005 _H	PRCLK/(2 × 5)	PRCLK/5																												
...	PRCLK/(2 × URTHnBRS[11:0])	PRCLK/URTHnBRS[11:0]																												
FFE _H	PRCLK/(2 × 4094)	PRCLK/4094																												
FFF _H	PRCLK/(2 × 4095)	PRCLK/4095																												

Caution Writing to this register is only allowed while the operation of UARTHn is disabled (URTHnCTL0.URTHnPW = 0).

Clock supply The value of the UARTHn input clock is defined in Table 22-3, UARTHn Clock Supply.

(4) URTHnTRG – UARTHn Trigger Register

This register controls use of the BF as a trigger for transmission or reception by UARTHn.

Access This register can be read/written in 8- or 1-bit units.

Address <URTHn_base1> + 0C_H

Initial value 00_H

This register is initialized by a reset from any source.

7	6	5	4	3	2	1	0
0	URTHn BRT	URTHn BTT	0	0	0	0	0
R	R/W	R/W	R	R	R	R	R

Table 22-11 URTHnTRG Register Contents (1/2)

Bit Position	Bit Name	Function
6	URTHnBRT	<p>BF reception trigger</p> <p>0: The value read is always 0. Writing 0 is ignored.</p> <p>1: Enables BF reception.</p> <ul style="list-style-type: none"> When reception is enabled, writing 1 to this bit enables BF reception (URTHnSTR0.URTHnSSBR = 1) and BF reception processing begins when the falling edge of the receive serial signal is detected. If 1 is written to this bit during reception processing, the current reception processing is terminated. Consequently, the received value is not stored, the framing, parity and overflow error bits are not updated on the basis of the received data, and no interrupts are generated. Meanwhile, the value of the BF counter stays in continuous use. After BF reception, the reception status is set according to the URTHnCTL1.URTHnSLBM setting. Setting this bit to 1 is only allowed while reception is enabled (URTHnCTL0.URTHnPW = URTHnCTL0.URTHnRXE = 1). <p>After URTHnBRT is set to 1, completion of BF reception is reported by either of the following 2 methods, based on the URTHnCTL1.URTHnSLBM setting: After setting the URTHnBRT bit to 1, do not write 1 to the URTHnBRT bit again until a reception-complete interrupt is generated.</p> <ul style="list-style-type: none"> If URTHnCTL1.URTHnSLBM = 0, a reception interrupt request URTHnTIR is output on completion of BF reception. If URTHnCTL1.URTHnSLBM = 1, when BF reception is complete, URTHnSTR1.URTHnBSF is set to 1 and a status interrupt request (URTHnTIS) is output on completion of BF reception.

Table 22-11 URTHnTRG Register Contents (2/2)

Bit Position	Bit Name	Function
5	URTHnBTT	<p>BF transmission trigger</p> <p>0: The value read is always 0. Writing 0 is ignored.</p> <p>1: Triggers BF transmission.</p> <ul style="list-style-type: none"> • Writing 1 to this bit while URTHnSTR0.URTHnSSBT = 0 and transmission is enabled (URTHnSTR1.URTHnDCE = 0) causes a BF transmission request to be issued and URTHnSTR0.URTHnSSBT to be set to 1. • Writing 1 to this bit during data transmission leads to the transmission of a BF after the transmission in progress is completed. Even if 1 is again written to this bit before BF transmission is completed, the BF will only be transmitted once. • When transmission is enabled (URTHnCTL0.URTHnPW = URTHnCTL0.URTHnTXE = 1), writing 1 to this bit clears all previously set data transmission requests (for which the data have not been transmitted), leaving only any BF transmission request. If a new value is written to the URTHnTX.URTHnTX[7:0] bits after 1 is written to this bit, the data are transmitted after the BF. • If both a BF transmit request and a data transmit request have been set when a transmission starts, the BF transmission takes priority. • When URTHnSTR1.URTHnDCE = 1, writing 1 to this bit is ignored. • Setting this bit is only allowed when transmission is enabled (URTHnCTL0.URTHnPW = 1, URTHnCTL0.URTHnTXE = 1).

(5) URTHnSTR0 – UARTHn Status Register 0

This register indicates the current status of serial data transmissions.

Access This register can be read in 8- or 1-bit units. This register is writable if UARTHn operation is disabled (URTHnCTL0.URTHnPW = 0). If this is enabled (URTHnCTL0.URTHnPW = 1), any written values are disregarded and the register takes on its initial value.

Address <URTHn_base1> + 10_H

Initial value 00_H

A reset from any source or, when UARTHn operation is enabled, setting URTHnCTL0.URTHnPW 0 to 1 or 1 to 0, will initialize the bits.

7	6	5	4	3	2	1	0
0	URTHn SSBR*1	URTHn SSBT*2	0	0	0	URTHn SSR*1	URTHn SST*2
R	R	R	R	R	R	R	R

Note 1. These bits are also initialized if reception is disabled by URTHnCTL0.URTHnRXE = 0.

Note 2. These bits are also initialized if transmission is disabled by URTHnCTL0.URTHnTXE = 0.

Table 22-12 URTHnSTR0 Register Contents

Bit Position	Bit Name	Function
6	URTHnSSBR	BF reception enable/disable status indication 0: BF reception disabled 1: BF reception has been enabled by setting URTHnTRG.URTHnBRT to 1 (BF reception standby mode or BF reception busy).
5	URTHnSSBT	BF transmission enable/disable status indication 0: BF transmission disabled 1: BF transmission has been enabled by setting URTHnTRG.URTHnBTT to 1 (BF transmission standby mode or BF transmission busy).
1	URTHnSSR	Data reception state 0: Data reception is not in progress. 1: Data reception is in progress (data reception busy)
0	URTHnSST	Data transmission state 0: No transmission is pending or ongoing 1: Transfer of data in URTHnTX.URTHnTX[7:0] is pending or transmission is in progress

(6) URTHnSTR1 – UARTHn Status Register 1

This register indicates results of serial data transmissions.

Access This register can be read in 8- or 1-bit units. This register is writable if UARTHn operation is disabled (URTHnCTL0.URTHnPW = 0). If this is enabled (URTHnCTL0.URTHnPW = 1), any written values are disregarded and the register takes on its initial value.

Address <URTHn_base1> + 14_H

Initial value 00_H

A reset from any source or, when UARTHn operation is enabled, setting URTHnCTL0.URTHnPW 0 to 1 or 1 to 0, will initialize the bits.

	7	6	5	4	3	2	1	0
	0	URTHn IDM* ¹	URTHn EBD* ¹	URTHn BSF* ¹	URTHn DCE* ²	URTHn PE* ¹	URTHn FE* ¹	URTHn OVE* ¹
	R	R	R	R	R	R	R	R

Note 1. These bits are also initialized if reception is disabled by URTHnCTL0.URTHnRXE = 0.

Note 2. This bit is also initialized if transmission is disabled by URTHnCTL0.URTHnTXE = 0.

Table 22-13 URTHnSTR1 Register Contents (1/2)

Bit Position	Bit Name	Function
6	URTHnIDM	ID value match detection flag 0: ID value match with received data is not detected 1: ID value match with received data is detected <ul style="list-style-type: none"> This bit is set to 1 if ID value matched when ID comparison is enabled (URTHnOPT1.URTHnIDCN = 1) by transfer of extension bit (9th bit), and the extension bit detection interrupt is enabled (URTHnOPT0.URTHnEGE = 1). For details on ID match detection, refer to Section 22.6.5, Extension bit Detection/ID Compare-Match Detection.
5	URTHnEBD	Extension bit detection flag 0: Extension bit of received data is not detected 1: Extension bit of received data is detected <ul style="list-style-type: none"> When the transmission of the extension bit (9th bit) is enabled (URTHnOPT0.URTHnEBE = 1) and the extension bit detection interrupt is enabled (URTHnOPT0.URTHnEGE = 1), this bit is set to 1 if an extension bit is detected. For details on extension bit detection, refer to Section 22.6.5, Extension bit Detection/ID Compare-Match Detection.
4	URTHnBSF	BF reception successful flag 0: BF reception is not detected when URTHnSLBM = 1 1: BF reception is detected when URTHnSLBM = 1 When the BF reception mode selection bit (URTHnCTL1.URTHnSLBM) is set in LIN communication mode, it is necessary to read this bit by the status interrupt processing and to confirm the beginning of a new frame slot.
3	URTHnDCE	Data consistency error flag 0: Error in consistency between transmitted and received data (or a transmitted and received BF) is not detected 1: Error in consistency between transmitted and received data (or a transmitted and received BF) is detected

Table 22-13 URTHnSTR1 Register Contents (2/2)

Bit Position	Bit Name	Function
2	URTHnPE	Parity error flag 0: Parity error is not detected in received data 1: Parity error is detected in received data The operation of URTHnSTR.URTHnPE is controlled by the settings of the URTHnCTL1.URTHnSLP[1:0]. Note: In consecutive two-frame reception mode, this reflects the state of reception of 2 frames being completed.
1	URTHnFE	Framing error flag 0: Framing error is not detected in received data 1: Framing error is detected in received data Note: In consecutive two-frame reception mode, this reflects the state of reception of the two frames being completed.
0	URTHnOVE	Overrun error flag 0: Overrun error is not detected in received data 1: Overrun error is detected in received data When an overrun error occurs, the data are discarded, and the next received data are not written to the receive data register (URTHnRX).

Note If the bits of this register are set (1) and cleared (0) at the same time, setting takes priority over clearing.

Caution For details on error detection, see Section 22.6.9, Transmission Data Consistency Check, and Section 22.6.13, Reception Errors. In case reception and transmission are enabled and data consistency checking reveals an error (URTHnSTR1.URTHnDCE = 1), follow the procedure below before transmitting further data:

- Disable transmission by setting URTHnCTL0.URTHnTXE = 0.
- Enable transmission by setting URTHnCTL0.URTHnTXE = 1.
- Initiate transmission by setting URTHnTRG.URTHnBTT (BF Transmission trigger) or writing any value to URTHnTX.

Further transmission can now proceed.

(7) URTHnSTC – UARTHn Status Clear Register

This register is used to clear the status bits of the status register 1 (URTHnSTR1).

Access This register can be read/written in 8-bit units.

Reading this register always returns 00_H.

Address <URTHn_base1> +18_H

Initial value 00_H

This register is initialized by a reset from any source.

	7	6	5	4	3	2	1	0
	0	URTHn CLIM	URTHn CLEB	URTHn CLBS	URTHn CLDC	URTHn CLP	URTHn CLF	URTHn CLOV
	R	R/W	R/W	R/W	R/W	R/W	R/W	R/W

Table 22-14 URTHnSTC Register Contents

Bit Position	Bit Name	Function
6	URTHnCLIM	Controls clearing of the ID value match detection flag (URTHnSTR1.URTHnIDM bit). 0: Writing 0 is ignored. 1: Writing 1 clears URTHnSTR1.URTHnIDM.
5	URTHnCLEB	Controls clearing of the extension bit detection flag (URTHnSTR1.URTHnEBD bit). 0: Writing 0 is ignored. 1: Writing 1 clears URTHnSTR1.URTHnEBD.
4	URTHnCLBS	Controls clearing of the BF reception successful flag (URTHnSTR1.URTHnBSF bit). 0: Writing 0 is ignored. 1: Writing 1 clears URTHnSTR1.URTHnBSF.
3	URTHnCLDC	Controls clearing of the data consistency error flag (URTHnSTR1.URTHnDCE bit). 0: Writing 0 is ignored. 1: Writing 1 clears URTHnSTR1.URTHnDCE. Clearing URTHnSTR1.URTHnDCE by setting this bit to 1 will initiate the next transmission. Accordingly, take care when using this in LIN communications.
2	URTHnCLP	Controls clearing of the parity error flag (URTHnSTR1.URTHnPE bit). 0: Writing 0 is ignored. 1: Writing 1 clears URTHnSTR1.URTHnPE.
1	URTHnCLF	Controls clearing of the framing error flag (URTHnSTR1.URTHnFE bit). 0: Writing 0 is ignored. 1: Writing 1 clears URTHnSTR1.URTHnFE.
0	URTHnCLOV	Controls clearing of the overrun error flag (URTHnSTR1.URTHnOVE bit). 0: Writing 0 is ignored. 1: Writing 1 clears URTHnSTR1.URTHnOVE.

(8) URTHnOPT0 – UARTHn Option Register 0

This register specifies the optional features for use in serial transfer by the UARTHn interface.

Access This register can be read/written in 16-bit units.

Address <URTHn_base0> + 48_H

Initial value 0000_H

This register is initialized by a reset from any source.

15	14	13	12	11	10	9	8
URTHn EBE	URTHn EGE	URTHn EJL	URTHn SCFR	URTHn RSFR	URTHn RXFR	URTHn RTSL	URTHn CTSL
R/W	R/W	R/W	R/W	R/W	R/W	R/W	R/W
7	6	5	4	3	2	1	0
0	URTHn HS	URTHn DM	URTHn MSS	URTHn SAS	URTHn F2R	URTHn F2T	0
R	R/W	R/W	R/W	R/W	R/W	R/W	R

Table 22-15 URTHnOPT0 Register Contents (1/3)

Bit Position	Bit Name	Function
15	URTHnEBE	<p>Enables and disables operation with the extension bit</p> <p>0: Disables extension bit operation The bit length set for transmission and reception (URTHnCTL1.URTHnCLG) is used in transmitting and receiving data.</p> <p>1: Enables extension bit operation The character length used in transmitting and receiving data is 9 bits (an extension bit is appended to each 8-bit character for transmission and reception).</p> <ul style="list-style-type: none"> The setting of this bit is only valid when the setting of the bit length for transmission and reception is 8 bits (URTHnCTL1.URTHnCLG = 1). The setting becomes invalid when the length is 7 bits (URTHnCTL1.URTHnCLG = 0), in which case data are transmitted and received with a character length of 7 bits. When the transmission/reception is performed in the LIN format, set URTHnEBE to 0. Changing this bit is only allowed while the UARTHn operation is disabled (URTHnCTL0.URTHnPW = 0). For details on extension bit detection, refer to Section 22.6.5, Extension bit Detection/ID Compare-Match Detection.

Table 22-15 URTHnOPT0 Register Contents (2/3)

Bit Position	Bit Name	Function
14	URTHnEGE	<p>Enables and disables the extension bit detection interrupts.</p> <p>0: Disables extension bit detection interrupts Detection of an extension bit under the condition set by URTHnEJL does not change the extension bit detection flag (URTHnSTR1.URTHnEBD), and an extension bit detection interrupt will not be generated.</p> <p>1: Enables extension bit detection interrupts Detection of an extension bit under the condition set by URTHnEJL leads to setting of the extension bit detection flag (URTHnSTR1.URTHnEBD) and generation of an extension bit detection interrupt.</p> <ul style="list-style-type: none"> • This setting becomes valid when the setting of the bit length for transmission and reception is 8 bits (URTHnCTL1.URTHnCLG = 1) and operation with the extension bit is enabled (URTHnEBE = 1). • Changing this bit is only allowed while operation of UARTHn is disabled (URTHnCTL0.URTHnPW = 0). • For details on extension bit detection, refer to Section 22.6.5, Extension bit Detection/ID Compare-Match Detection.
13	URTHnEJL	<p>Selects the condition for detecting the extension bit.</p> <p>0: The value zero is the condition for detecting the extension bit. 1: The value one is the condition for detecting the extension bit.</p> <ul style="list-style-type: none"> • As condition for extension bit detection, this setting selects a level of the extension bit (0 or 1) after control of the reception data level (URTHnCTL1.URTHnRDL). • While ID comparison is enabled (URTHnOPT1.URTHnIDCN = 1), a match in ID comparison after detection of the extension bit produces an extension bit detection interrupt. • Changing this bit is only allowed while the UARTHn operation is disabled (URTHnCTL0.URTHnPW = 0). • For details on extension bit detection, refer to Section 22.6.5, Extension bit Detection/ID Compare-Match Detection.
12	URTHnSCFR	<p>Enables and disables the noise filter for the synchronizing clock input.</p> <p>0: Enables noise filter 1: Disables noise filter</p> <ul style="list-style-type: none"> • If slave mode and data consistency checking are enabled (i.e. if URTHnCTL0.URTHnSLDC = 1), set this register to the same value as URTHnRXFR. • Changing this bit is only allowed while UARTHn operation is disabled (URTHnCTL0.URTHnPW = 0).
11	URTHnRSFR	<p>Enables and disables the noise filter for the handshake signal input.</p> <p>0: Enables noise filter 1: Disables noise filter</p> <ul style="list-style-type: none"> • Changing this bit is only allowed while UARTHn operation is disabled (URTHnCTL0.URTHnPW = 0).
10	URTHnRXFR	<p>Enables and disables the noise filter for received data.</p> <p>0: Enables noise filter 1: Disables noise filter</p> <ul style="list-style-type: none"> • When operation is as a slave in synchronous mode and data consistency checking is enabled (URTHnCTL0.URTHnSLDC = 1), set this bit to the same value as URTHnSCFR. • Changing this bit is only allowed while UARTHn operation is disabled (URTHnCTL0.URTHnPW = 0).
9	URTHnRTSL	<p>Selects the active level of the output signal for handshaking.</p> <p>0: Low is the active level. 1: High is the active level.</p> <ul style="list-style-type: none"> • Changing this bit is only allowed while UARTHn operation is disabled (URTHnCTL0.URTHnPW = 0).

Table 22-15 URTHnOPT0 Register Contents (3/3)

Bit Position	Bit Name	Function
8	URTHnCTSL	<p>Selects the active level of the input signal for handshaking.</p> <p>0: Low is the active level. 1: High is the active level.</p> <ul style="list-style-type: none"> Changing this bit is only allowed while UARTHn operation is disabled (URTHnCTL0.URTHnPW = 0).
6	URTHnHS	<p>Enables and disables handshaking.</p> <p>0: Disables handshaking 1: Enables handshaking</p> <ul style="list-style-type: none"> Disable loop-back control (URTHnCTL1.URTHnLPM = 0) if the setting of the URTHnHS bit is 1. Changing this bit is only allowed while UARTHn operation is disabled (URTHnCTL0.URTHnPW = 0).
5	URTHnDM	<p>Selects the timing of sampling for data reception in clock synchronous mode.</p> <p>0: Received data are sampled on rising edges of the synchronizing clock (normal sampling). 1: Received data are sampled on falling edges of the synchronizing clock (delayed sampling).</p> <ul style="list-style-type: none"> Changes to this bit only become effective when clock synchronous mode is selected (URTHnSAS = 1). Changing this bit is only allowed while UARTHn operation is disabled (URTHnCTL0.URTHnPW = 0).
4	URTHnMSS	<p>Selects master or slave operation in clock synchronous mode.</p> <p>0: Master The master outputs the synchronizing clock for use in transmission and reception. 1: Slave The synchronizing clock supplied by the master is used in transmission and reception.</p> <ul style="list-style-type: none"> Changes to this bit only become effective when clock synchronous mode is selected (URTHnSAS = 1). Changing this bit is only allowed while UARTHn operation is disabled (URTHnCTL0.URTHnPW = 0).
3	URTHnSAS	<p>Selects the operating mode for UARTHn.</p> <p>0: Asynchronous mode 1: Synchronous mode</p> <ul style="list-style-type: none"> Changing this bit is only allowed while UARTHn operation is disabled (URTHnCTL0.URTHnPW = 0). Only use the interface in asynchronous mode after disabling the clock pin (URTH0SC).
2	URTHnF2R	<p>Selects the length of data for reception as 1 frame or 2 frames.</p> <p>0: Selects reception of 1 frame 1: Selects reception of 2 frames</p> <ul style="list-style-type: none"> Set this bit (URTHnOPT0.URTHnF2R) to 0 when data consistency checking is enabled (URTHnCTL0.URTHnSLDC = 1) or ID value compare-match detection is enabled (URTHnOPT1.URTHnIDCN = 1). Changing this bit is only allowed while UARTHn operation is disabled (URTHnCTL0.URTHnPW = 0).
1	URTHnF2T	<p>Selects the length of data for transmission as 1 frame or 2 frames.</p> <p>0: Selects transmission of 1 frame 1: Selects transmission of 2 frames</p> <ul style="list-style-type: none"> Changing this bit is only allowed while UARTHn operation is disabled (URTHnCTL0.URTHnPW = 0).

(9) URTHnOPT1 – UARTHn Option Register 1

This register specifies the optional features for use in serial transfer by the UARTHn interface.

Access This register can be read/written in 8- or 1-bit units.
Reading this register always returns 00_H.

Address <URTHn_base1> +04_H

Initial value 00_H

This register is initialized by a reset from any source.

	7	6	5	4	3	2	1	0
URTHn IDCN	0	0	0	0	0	0	0	0
	R/W	R	R	R	R	R	R	R

Table 22-16 URTHnOPT1 Register Contents

Bit Position	Bit Name	Function
7	URTHnIDCN	Enables and disables ID match detection. 0: ID match detection at the time of transfer of an extension bit (9th bit) is disabled. 1: ID match detection at the time of transfer of an extension bit (9th bit) is enabled. <ul style="list-style-type: none"> • The setting of this bit is not effective when the unit of transfer is 7 or 8 bits. • Clear this bit (to 0) if the current setting is for two-frame data reception (URTHnOPT0.URTHnF2R = 0) or handshaking (URTHnOPT0.URTHnHS = 1). • For details on ID match detection, refer to Section 22.6.5, Extension bit Detection/ID Compare-Match Detection.

(10) URTHnOPT2 – UARTHn Option Register 2

This register specifies the optional features for use in serial transfer by the UARTHn interface.

Access This register can be read/written in 16-bit units.

Address <URTHn_base1> + 08_H

Initial value 0000_H

This register is initialized by a reset from any source.

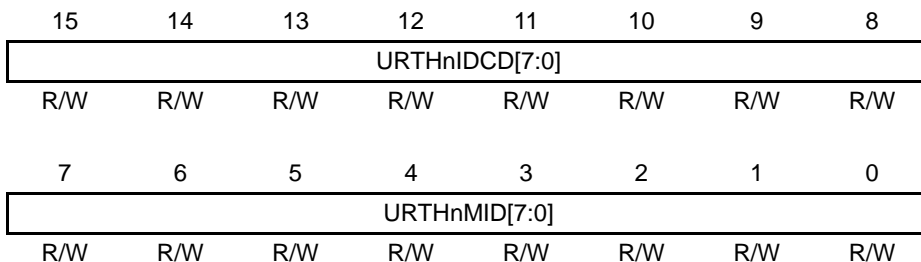

Table 22-17 URTHnOPT2 Register Contents

Bit Position	Bit Name	Function
15 to 8	URTHnIDCD [7:0]	Sets the ID value for comparison at the time the extension bit (9th bit) is transferred. <ul style="list-style-type: none"> For details on extension bit detection, refer to Section 22.6.5, Extension bit Detection/ID Compare-Match Detection.
7 to 0	URTHnMID [7:0]	Specifies which bits of the ID values are compared. <ul style="list-style-type: none"> 0: The corresponding bit is compared at the time the extension bit (9th bit) is transferred. 1: The corresponding bit is not compared at the time the extension bit (9th bit) is transferred. <ul style="list-style-type: none"> For details on ID match detection, refer to Section 22.6.5, Extension bit Detection/ID Compare-Match Detection.

(11) URTHnRX – UARTHn Receive Data Register

This register stores received data.

The data stored in the reception shift register are transferred to the URTHnRX register upon completion of the reception of one frame containing 7 or 8 bits of data.

This register corresponds to the bits 7 to 0 in the URTHnERXW register.

7-bit transfers If the data length has been specified as 7 bits (URTHnCTL1.URTHnCLG = 0), the received data stored in this register are transferred in accord with the specified direction for transfer (MSB-first/LSB-first) as described below.

- With LSB-first reception (URTHnCTL1.URTHnSLD = 1), the received data are transferred to URTHnRX[6:0] and the MSB (URTHnRX[7]) always becomes 0.
- With MSB-first reception (URTHnCTL1.URTHnSLD = 0), the received data are transferred to URTHnRX[7:1] and the LSB (URTHnRX[0]) bit always becomes 0.
- For details on data formats, refer to Section 22.6.1, Data Formats.

Overrun error When an overrun error (URTHnSTR1.URTHnOVE = 1) occurs, data received at the time are not transferred to URTHnRX but are discarded.

When processing for reception ends and data reception is confirmed without any overrun errors, the received data are stored in the URTHnRX register in the specified storage format.

This register is writable if UARTHn operation is disabled (URTHnCTL0.URTHnPW = 0). If this is enabled (URTHnCTL0.URTHnPW = 1), any written values are disregarded and the register takes on its initial value.

Access This register can be read in 8-bit units.

Address <URTHn_base1> + 1C_H

Initial value FF_H

A reset from any source or, when UARTHn operation is enabled, changing the value of URTHnCTL0.URTHnPW from 0 to 1, will initialize the bits.

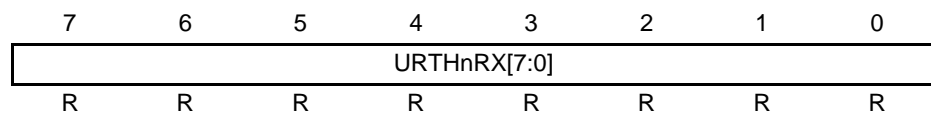

Table 22-18 URTHnRX Register Contents

Bit Position	Bit Name	Function
7 to 0	URTHnRX [7:0]	UARTHn receive data (See Table 22-22, Accesses according to Reception Modes.)

Caution In the consecutive two-frame transfer, the receive data register is only accessible in 16-bit units (URTHnRXHL). Do not write to this register in 8-bit units.

(12) URTHnRXHL – UARTHn Receive Data Register HL

This register stores received data.

The value stored in the reception shift register is transferred to the URTHnRXHL register upon completion of reception of data containing one frame with 9 bits of data.

This register corresponds to bits 15 to 0 in the URTHnERXW register.

Access This register can be read in 16-bit units.

Address <URTHn_base1> + 20_H

Initial value FFFF_H

A reset from any source or, when UARTHn operation is enabled, setting URTHnCTL0.URTHnPW = 1, will initialize the bits.

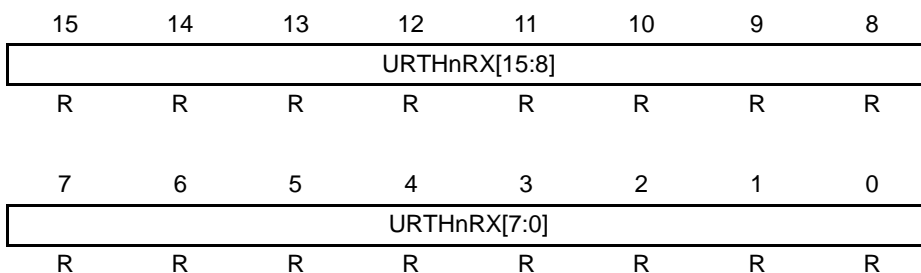

Table 22-19 URTHnRXHL Register Contents

Bit Position	Bit Name	Function
15 to 0	URTHnRX [15:0]	UARTHn receive data (See Table 22-22, Accesses according to Reception Modes.)

(13) URTHnERX – UARTHn Extension bit Receive Data Register

This register stores received data.

The extension bit data stored in the reception shift register is transferred to the URTHnERX register upon completion of reception of data.

This register corresponds to the bits 23 to 16 in the URTHnERXW register.

Access This register can be read in 8-bit units.

Address <URTHn_base1> + 24_H

Initial value 11_H

A reset from any source or, when UARTHn operation is enabled, setting URTHnCTL0.URTHnPW = 1, will initialize the bits.

7	6	5	4	3	2	1	0
0	0	0	URTHn ERXH8	0	0	0	URTHn ERXL8
R	R	R	R	R	R	R	R

Table 22-20 URTHnERX Register Contents

Bit Position	Bit Name	Function
4	URTHn ERXH8	Extension bit of UARTHn received data (See Table 22-22, Accesses according to Reception Modes.)
0	URTHn ERXL8	Extension bit of UARTHn received data (See Table 22-22, Accesses according to Reception Modes.)

(14) URTHnERXW – UARTHn Extension bit Receive Word Data Register

This register stores received data.

The data stored in the reception shift register is transferred to the URTHnERXW register upon completion of reception of data.

Access This register can be read in 32-bit units.

Address <URTHn_base1> + 28_H

Initial value 0011FFFF_H

A reset from any source or, when UARTHn operation is enabled, setting URTHnCTL0.URTHnPW = 1, will initialize the bits.

31	30	29	28	27	26	25	24
0	0	0	0	0	0	0	0
R	R	R	R	R	R	R	R
23	22	21	20	19	18	17	16
0	0	0	URTHn ERXH8	0	0	0	URTHn ERXL8
R	R	R	R	R	R	R	R
15	14	13	12	11	10	9	8
URTHnRX[15:8]							
R	R	R	R	R	R	R	R
7	6	5	4	3	2	1	0
URTHnRX[7:0]							
R	R	R	R	R	R	R	R

Table 22-21 URTHnERXW Register Contents

Bit Position	Bit Name	Function
20	URTHn ERXH8	Extension bit of UARTHn received data
16	URTHn ERXL8	Extension bit of UARTHn received data
15 to 0	URTHn RX[15:0]	UARTHn received data

Table 22-22 Accesses according to Reception Modes

Reception Mode	Data	Extension Bit
1-frame 8-bit data transfer	URTHnRX[7:0]	
1-frame 7-bit data transfer (MSB first)	URTHnRX[7:1]	
1-frame 7-bit data transfer (LSB first)	URTHnRX[6:0]	
1-frame extension bit transfer	URTHnRX[7:0]	URTHnRX8 or URTHnERXL8
2-frame 8-bit data transfer	1st frame: URTHnRX[15:8] 2nd frame: URTHnRX[7:0]	
2-frame 7-bit data transfer (MSB first)	1st frame: URTHnRX[15:9] 2nd frame: URTHnRX[7:1]	
2-frame 7-bit data transfer (LSB first)	1st frame: URTHnRX[14:8] 2nd frame: URTHnRX[6:0]	
2-frame extension bit transfer	1st frame: URTHnRX[15:8] 2nd frame: URTHnRX[7:0]	1st frame: URTHnERXH8 2nd frame: URTHnERXL8

Caution If data and the extension bit are read using different registers, the extension bit (URTHnERX) should be read first.

(15) URTHnTX – UARTHn Transmit Data Register

This register is used to store data to be transmitted.

Data for transmission in the URTHnTX register are stored in the transmission shift register in the data format specified for transmission.

This register corresponds to bits 7 to 0 in the URTHnETXW register.

7-bit transfers If the data length has been specified as 7 bits (URTHnCTL1.URTHnCLG = 0), the transmitted data stored in this register are transferred in accord with the specified direction for transfer (MSB-first/LSB-first) as described below.

- If transmission is LSB-first (URTHnCTL1.URTHnSLD = 1), URTHnTX[6:0] is transferred to the shift register.
- If transmission is MSB-first (URTHnCTL1.URTHnSLD = 0), URTHnTX[7:1] is transferred to the shift register.

For details on data formats, refer to Section 22.6.1, Data Formats.

Access This register can be read/written in 8-bit units.

Address <URTHn_base1> + 2C_H

Initial value FF_H

This register is initialized by a reset from any source.

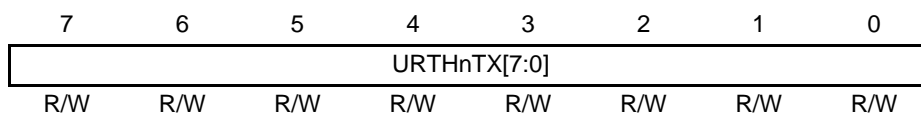

Table 22-23 URTHnTX Register Contents

Bit Position	Bit Name	Function
7 to 0	URTHnTX [7:0]	UARTHn transmit data (See Table 22-27, Accesses according to Transmission Modes.)

When transmission and reception are enabled (URTHnCTL0.URTHnPW = URTHnTXE = 1), writing to this register triggers the start of transmission.

Note If the next data are written to this register before ongoing transmission is completed, the interface will wait until the ongoing transmission is completed and then transmit the next data. Continuous transmission is thus possible.

Caution In the consecutive two-frame transfer, the receive data register is only accessible in 16-bit units (URTHnTXHL). Do not write to this register in 8-bit units.

(16) URTHnTXHL – UARTHn Transmit Data Register HL

This register is used to store data for transmission.

Data for transmission in the URTHnTXHL register are stored in the transmission shift register in accord with the data format specifications for transmission.

This register corresponds to bits 15 to 0 in the URTHnETXW register.

Access This register can be read/written in 16-bit units.

Address <URTHn_base1> + 30_H

Initial value FFFF_H

A reset from any source or, when UARTHn operation is enabled, setting URTHnCTL0.URTHnPW = 1, will initialize the bits.

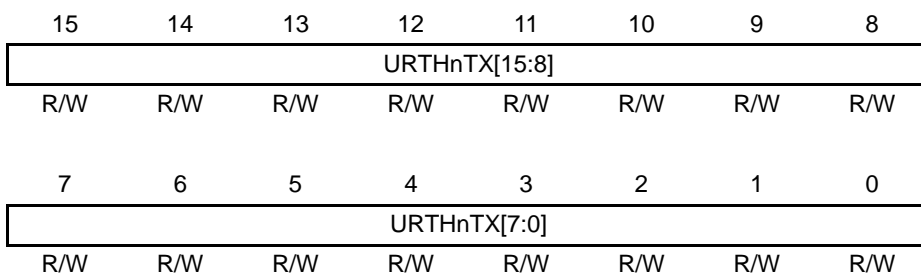

Table 22-24 URTHnTXHL Register Contents

Bit Position	Bit Name	Function
15 to 0	URTHnTX [15:0]	UARTHn transmit data (See Table 22-27, Accesses according to Transmission Modes.)

(17) URTHnETX – UARTHn Extension bit Transmit Data Register

This register is used to store data for transmission.

Data for transmission in the URTHnETX register are stored in the transmission shift register in accord with the data format specifications for transmission.

This register corresponds to the bits 23 to 16 in the URTHnETXW register.

Access This register can be read/written in 8-bit units.

Address <URTHn_base1> + 34_H

Initial value 11_H

A reset from any source or, when UARTHn operation is enabled, setting URTHnCTL0.URTHnPW = 1, will initialize the bits.

7	6	5	4	3	2	1	0
0	0	0	URTHn ETXH8	0	0	0	URTHn ETXL8
R	R	R	R/W	R	R	R	R/W

Table 22-25 URTHnETX Register Contents

Bit Position	Bit Name	Function
4	URTHn ETXH8	Extension bit of transmit data (See Table 22-27, Accesses according to Transmission Modes.)
0	URTHn ETXL8	Extension bit of transmit data (See Table 22-27, Accesses according to Transmission Modes.)

(18) URTHnETXW – UARTHn Extension bit Transmit Word Data Register

This register is used to store data for transmission.

Data for transmission in the URTHnETXW register are stored in the transmission shift register in accord with the data format specifications for transmission.

Access This register can be read/written in 32-bit units.

Address <URTHn_base1> + 38_H

Initial value 0011FFFF_H

A reset from any source or, when UARTHn operation is enabled, setting URTHnCTL0.URTHnPW = 1, will initialize the bits.

31	30	29	28	27	26	25	24
0	0	0	0	0	0	0	0
R	R	R	R	R	R	R	R
23	22	21	20	19	18	17	16
0	0	0	URTHn ETXH8	0	0	0	URTHn ETXL8
R	R	R	R/W	R	R	R	R/W
15	14	13	12	11	10	9	8
URTHnTX[15:8]							
R/W	R/W	R/W	R/W	R/W	R/W	R/W	R/W
7	6	5	4	3	2	1	0
URTHnTX[7:0]							
R/W	R/W	R/W	R/W	R/W	R/W	R/W	R/W

Table 22-26 URTHnETXW Register Contents

Bit Position	Bit Name	Function
20	URTHn ETXH8	Extension bit of UARTHn transmit data
16	URTHn ETXL8	Extension bit of UARTHn transmit data
15 to 0	URTHnTX [15:0]	UARTHn transmit data

Table 22-27 Accesses according to Transmission Modes

Transmission Mode	Data	Extension Bit
1-frame 8-bit data transfer	URTHnTX[7:0]	
1-frame 7-bit data transfer (MSB first)	URTHnTX[7:1]	
1-frame 7-bit data transfer (LSB first)	URTHnTX[6:0]	
1-frame extension bit transfer	URTHnTX[7:0]	URTHnTX8 or URTHnETXL8
2-frame 8-bit data transfer	First frame: URTHnTX[15:8] Second frame: URTHnTX[7:0]	
2-frame 7-bit data transfer (MSB first)	1st frame: URTHnTX[15:9] 2nd frame: URTHnTX[7:1]	
2-frame 7-bit data transfer (LSB first)	1st frame: URTHnTX[14:8] 2nd frame: URTHnTX[6:0]	
2-frame extension bit transfer	1st frame: URTHnTX[15:8] 2nd frame: URTHnTX[7:0]	1st frame: URTHnETXH8 2nd frame: URTHnETXL8

Caution If data and the extension bit are set in different registers, the extension bit (URTHnETX) should be set first.

(19) IC0REG0 – LIN Communications Slave Operation Baud-Rate Detection Register 0

LIN communications slave operation baud-rate detection register 0 is described below.

Access This register can be read/written in 32-bit units.

Address FFFFE00_H

Initial value 00000000_H

This register is initialized by a reset from any source.

31	30	29	28	27	26	25	24
IC0REG0 0151	IC0REG0 0150	IC0REG0 0141	IC0REG0 0140	IC0REG0 0131	IC0REG0 0130	IC0REG0 0121	IC0REG0 0120
R/W	R/W	R/W	R/W	R/W	R/W	R/W	R/W
23	22	21	20	19	18	17	16
IC0REG0 0111	IC0REG0 0110	IC0REG0 0101	IC0REG0 0100	IC0REG0 0091	IC0REG0 0090	IC0REG0 0081	IC0REG0 0080
R/W	R/W	R/W	R/W	R/W	R/W	R/W	R/W
15	14	13	12	11	10	9	8
IC0REG0 0071	IC0REG0 0070	IC0REG0 0061	IC0REG0 0060	IC0REG0 0051	IC0REG0 0050	IC0REG0 0041	IC0REG0 0040
R/W	R/W	R/W	R/W	R/W	R/W	R/W	R/W
7	6	5	4	3	2	1	0
IC0REG0 0031	IC0REG0 0030	IC0REG0 0021	IC0REG0 0020	IC0REG0 0011	IC0REG0 0010	IC0REG0 0001	IC0REG0 0000
R/W	R/W	R/W	R/W	R/W	R/W	R/W	R/W

Table 22-28 IC0REG0 Register Contents

Bit Position	Bit Name	Function															
31 to 0	IC0REG00m0, IC0REG00m1	Selects the signal to be input to TAUB0 ch (m). (m = 00 to 15) <table border="1" style="margin-top: 10px;"> <thead> <tr> <th>IC0REG0 0m1</th> <th>IC0REG0 0m0</th> <th>Description</th> </tr> </thead> <tbody> <tr> <td>0</td> <td>0</td> <td>Input TAUB0Im to timer input of TAUB0 ch (m).</td> </tr> <tr> <td>0</td> <td>1</td> <td>Input URTH0RXD to timer input of TAUB0 ch (m).</td> </tr> <tr> <td>1</td> <td>0</td> <td>Input URTH1RXD to timer input of TAUB0 ch (m).</td> </tr> <tr> <td>1</td> <td>1</td> <td>Setting prohibited</td> </tr> </tbody> </table>	IC0REG0 0m1	IC0REG0 0m0	Description	0	0	Input TAUB0Im to timer input of TAUB0 ch (m).	0	1	Input URTH0RXD to timer input of TAUB0 ch (m).	1	0	Input URTH1RXD to timer input of TAUB0 ch (m).	1	1	Setting prohibited
IC0REG0 0m1	IC0REG0 0m0	Description															
0	0	Input TAUB0Im to timer input of TAUB0 ch (m).															
0	1	Input URTH0RXD to timer input of TAUB0 ch (m).															
1	0	Input URTH1RXD to timer input of TAUB0 ch (m).															
1	1	Setting prohibited															

- Caution 1. Do not change the setting of this register while TAUB0 is operating.
- Caution 2. Do not connect a serial data input pin to TAUB0 unless it is for use in baud-rate detection.

22.5 Interrupt Request Signals

The following 3 interrupt request signals are generated by UARTHn.

- Transmission interrupt request URTHnTIT
- Reception interrupt request URTHnTIR
- Status interrupt request URTHnTIS

22.5.1 Transmission Interrupt Request URTHnTIT

When data for transmission are transferred from the URTHnTX register to the transmission shift register while transmission is enabled, a transmission interrupt request (URTHnTIT) will be generated.

The condition for generation of a transmission interrupt request depends on the setting of the URTHnCTL1.URTHnSLIT.

- At the start of transmission processing: URTHnCTL1.URTHnSLIT = 0.

A transmission interrupt request is issued when transmission of the first bit starts (the start bit in data transmission or the first bit of the BF in BF transmission). During data transmission, a transmission interrupt request is issued when data for transmission in the URTHnTX register are transferred to the transmission shift register.

- At the end of transmission processing: URTHnCTL1.URTHnSLIT = 1.

A transmission interrupt request is issued on completion of transmission of the last bit (the stop bit when the stop bit length is 1, or the 2nd of the stop bits when the stop bit length is 2).

Note Detection of a data consistency error leads to the generation of a URTHnTIS interrupt, so this interrupt will not be generated.

The following diagrams show when transmission interrupt requests are generated at the start and the end of transmission processing, respectively.

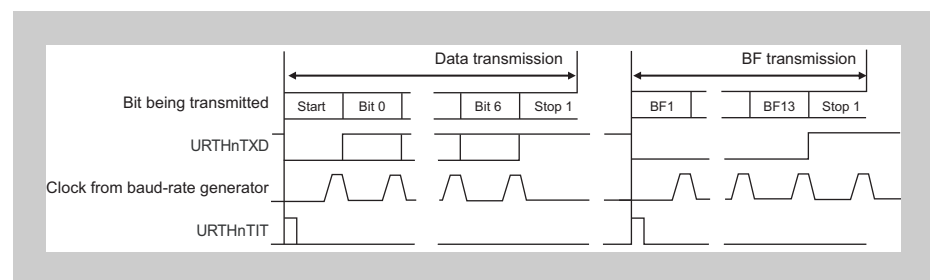

Figure 22-2 Timing of a Transmission Interrupt Request for URTHnCTL1.URTHnSLIT = 0

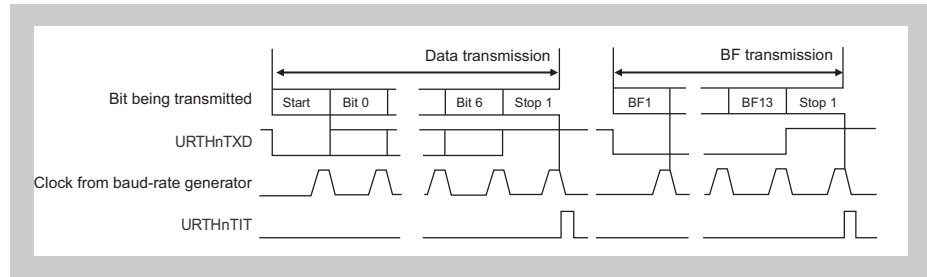

Figure 22-3 Timing of a Transmission Interrupt Request for $URTHnCTL1.URTHnSLG = 1$ and $URTHnSLIT = 1$.

22.5.2 Reception Interrupt Request URTHnTIR

A reception interrupt request is issued when the first bit of the stop bit is sampled.

In case of erroneous reception, the status interrupt (URTHnTIS) is generated instead of the URTHnTIR interrupt.

The reception interrupt request URTHnTIR is not generated while reception is disabled.

The following diagram shows the timing of the reception interrupt request during data/BF reception.

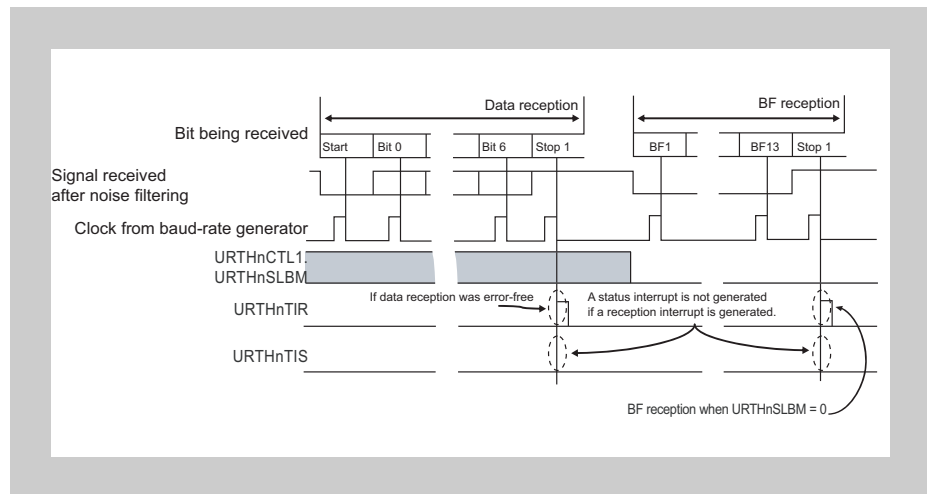

Figure 22-4 Timing of Reception Interrupt Request

22.5.3 Status Interrupt Request URTHnTIS

A status interrupt request (URTHnTIS) is generated in accord with the settings of status register 1 (URTHnSTR1) if an error condition is satisfied during reception or transmission.

When the BF reception mode selection bit is set in LIN communications mode ($URTHnCTL1.URTHnSLBM = 1$), the status interrupt request signal is generated when 11 or more consecutive bits at the low level (BF) are received.

22.6 Operation

22.6.1 Data Formats

The interface handles full-duplex serial data reception and transmission.

As shown in the figures below, one frame of data for transmission or received data consists of a start bit, the character bits, parity bit or bits, and stop bit or bits.

Several properties of transmitted and received data frames can be specified by control bits in the URTHnCTL1 register:

Table 22-29 Data Format Specification

Item	Options	Control Bits
Start bit	1 bit	Fixed
Character bits	7 bits/8 bits/9 bits	URTHnCTL1.URTHnCLG
Parity	Even parity/odd parity/0 parity/ no parity	URTHnCTL1.URTHnSLP[1:0]
Number of stop bits	1 bit/2 bits	URTHnCTL1.URTHnSLG
Data order	MSB first/LSB first	URTHnCTL1.URTHnSLD
Levels of transmitted data	Inverted/not inverted	URTHnCTL1.URTHnTDL
Levels of received data	Inverted/not inverted	URTHnCTL1.URTHnRDL

(1) UARTHn Transmit/Receive Data Format

- (a) 9-bit data length (extension bit), LSB first, even parity, 1 stop bit, data for transfer: 155_H

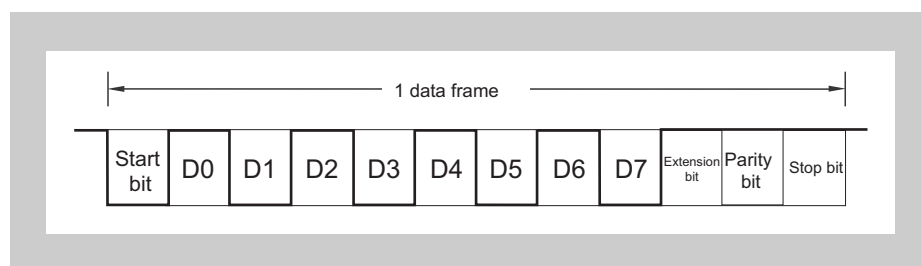

- (b) 9-bit data length (extension bit), MSB first, even parity, 1 stop bit, data for transfer: 155_H

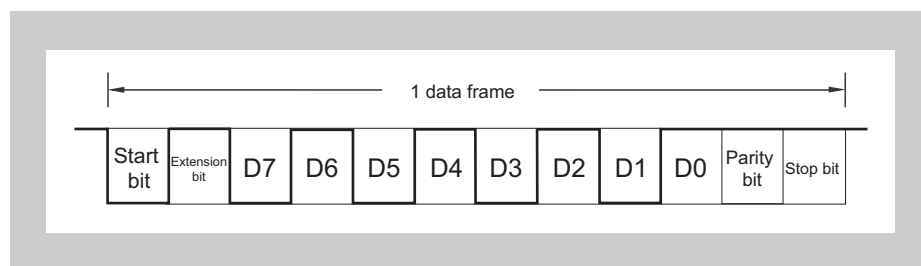

(c) 8-bit data length, LSB first, even parity, 1 stop bit, data for transfer: 55_H

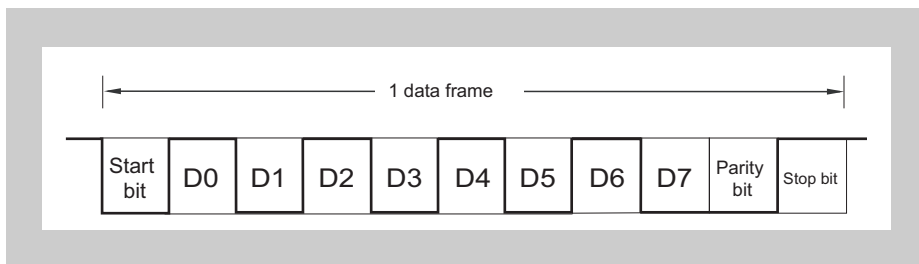

(d) 8-bit data length, MSB first, even parity, 1 stop bit, data for transfer: 55_H

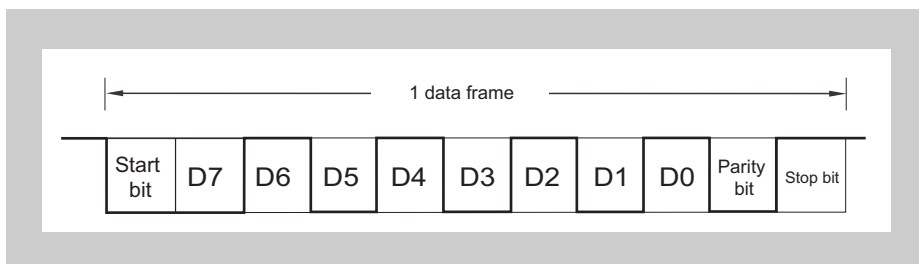

(e) 8-bit data length, MSB first, even parity, 1 stop bit, data for transfer: 55_H,
URTHnTTXD inverted

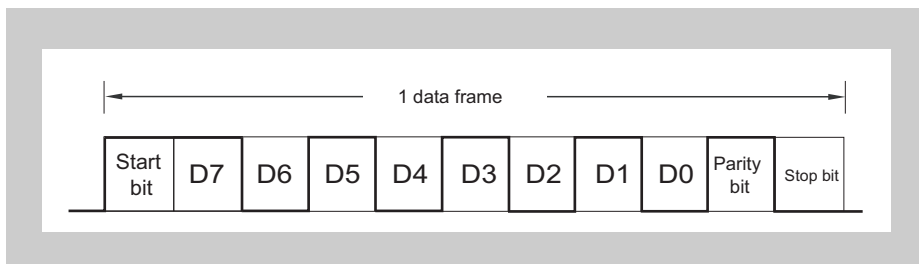

(f) 7-bit data length, LSB first, odd parity, 2 stop bits, data for transfer: 36_H

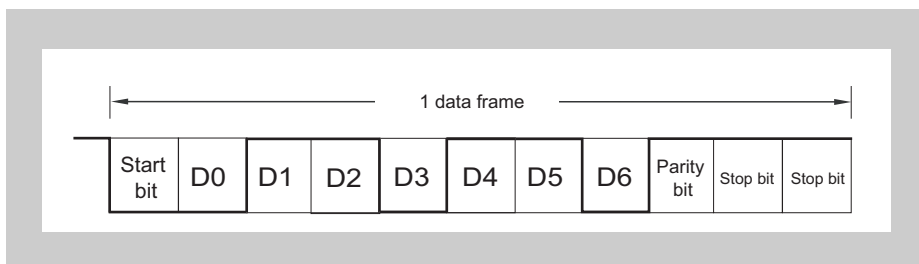

(g) 8-bit data length, LSB first, no parity, 1 stop bit, data for transfer: 87_H



22.6.2 Clock Synchronous Mode

In clock synchronous mode, data are transmitted and received in synchronization with the synchronizing clock (provided by the master side).

Normal sampling mode Data are transmitted (output) on falling edges and received data are sampled on rising edges of the synchronizing clock.

(a) Timing of transmission by the master

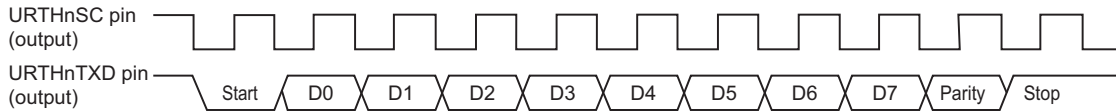

(b) Timing of reception by the master

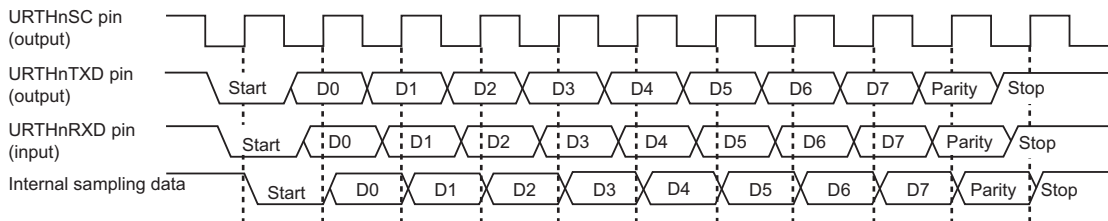

(c) Timing of transmission by the slave

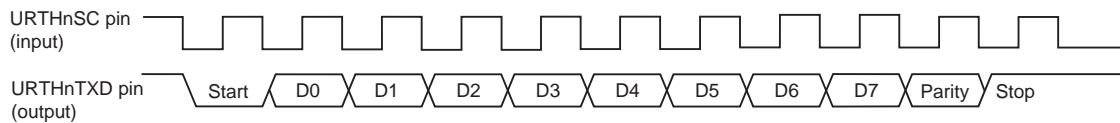

(d) Timing of reception by the slave

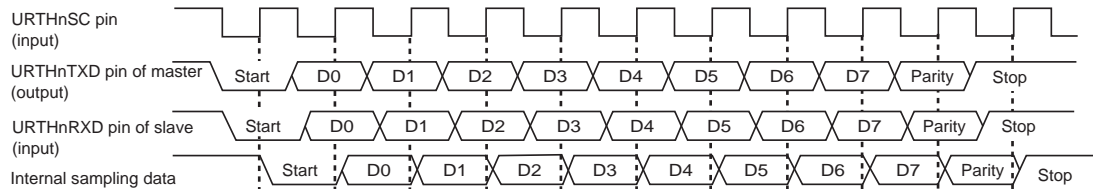

Delayed sampling mode In clock synchronous mode, received data are sampled on falling edges of the synchronizing clock.

(a) Examples of operation in delayed sampling mode (master, reception)

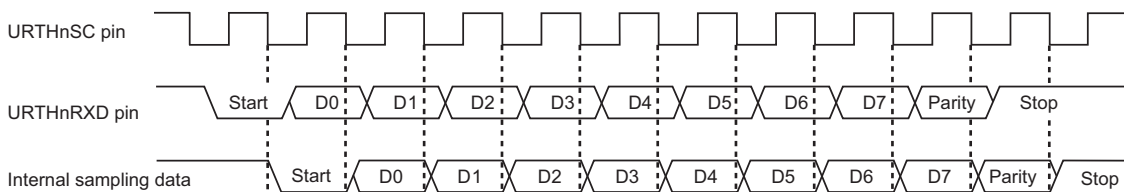

22.6.3 Handshake Mode

In this mode, the receive enable signal (URTHnRTS) and transmit enable signal (URTHnCTS) are used for handshaking in data transmission and reception.

Transmission After data are written to the transmit data register, the data are transmitted if the URTHnCTS signal input is at the active level. If the URTHnCTS signal is at the inactive level, data transmission will be suspended.

The data are transmitted immediately when the URTHnCTS signal goes to the active level. If the URTHnCTS signal is then changed to the inactive level while transmission is in progress, 1 frame of data will still be transmitted.

(a) Example of handshake signals (to wait for permission from URTHnCTS) in transmission

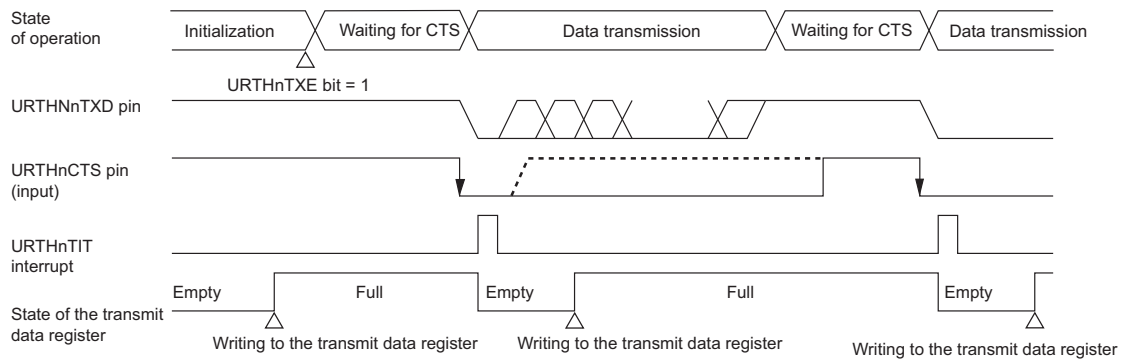

(b) Example of handshake signals (to wait for writing of data) in transmission

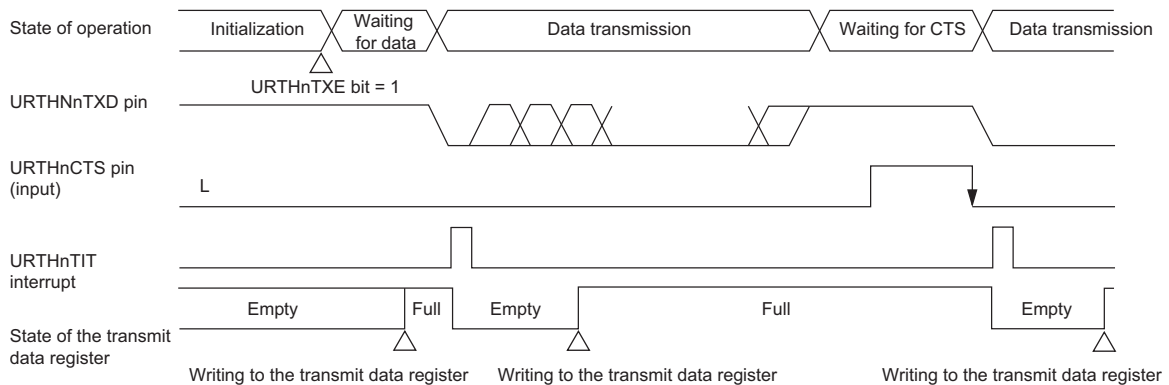

(c) Example of handshake signals (to wait for writing to URTHnTXE) in transmission

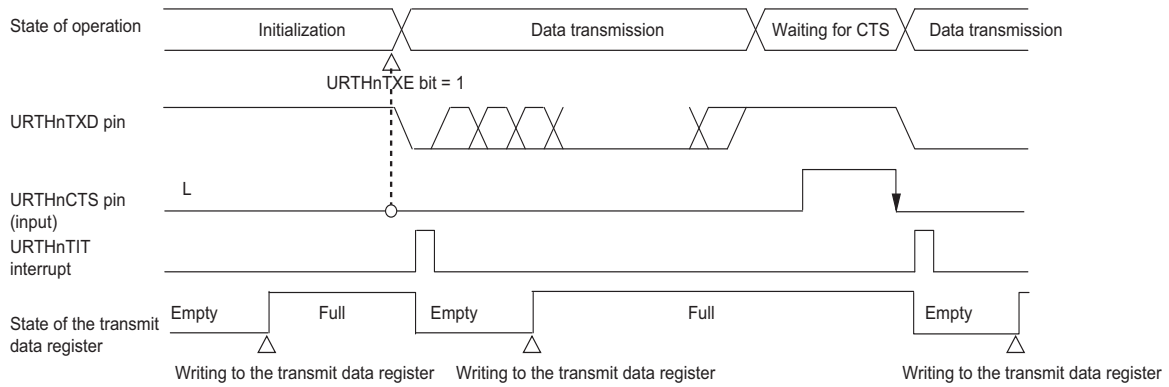

Reception When the receive data register is empty, the other party is notified of readiness to receive data by placing the reception enable signal (URTHnRTS) at the active level. When the receive data register is not empty (reading is incomplete), the URTHnRTS signal is placed at the inactive level because the register is not ready to receive data. The URTHnRTS signal must be placed at the inactive level at the time of sampling of the first bit of received data.

(a) Example of handshake signals in reception

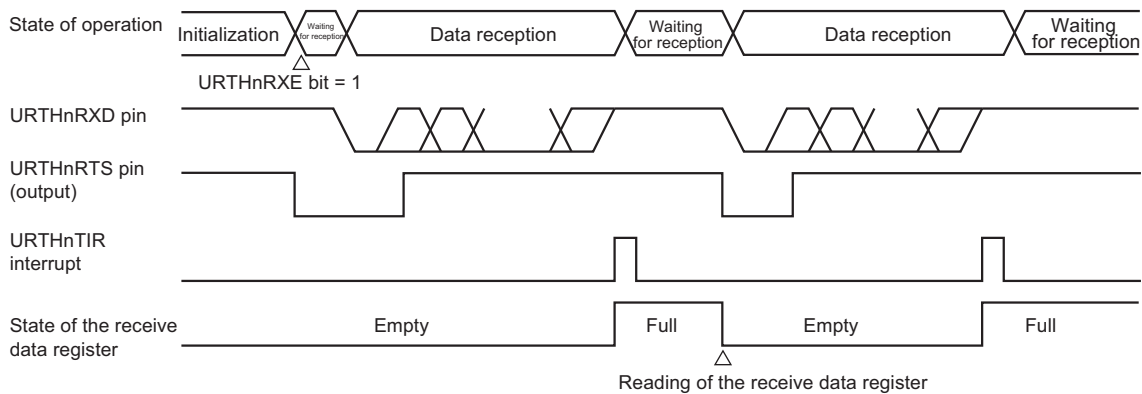

22.6.4 Consecutive Two-Frame Transfer Mode

Consecutive two-frame transfer mode allows the reception or transmission of two consecutive frames. The format in this case is as follows.

(a) Format for consecutive two-frame transfer

Format of consecutive two-frame transfer, LSB first:

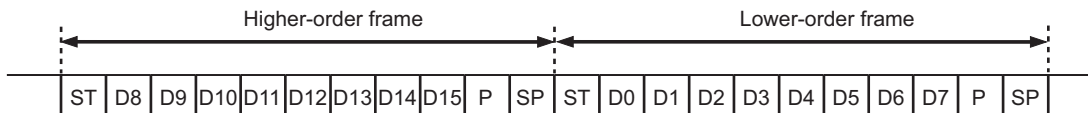

Format of consecutive two-frame transfer, MSB first:

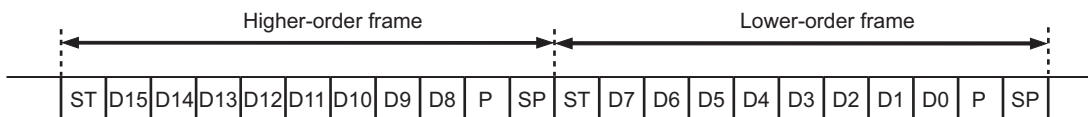

- ST: Start bit
- D0 to D15: Character bits
- P: Parity bit
- SP: Stop bit

Caution In the consecutive two-frame transfer, the transmit data register is only accessible in 16-bit units (URTHnTXHL, URTHnRXHL). Do not write to this register in 8-bit units.

(b) Timing of consecutive two-frame transmission (when URTHnCTL1.URTHnSLIT = 0)

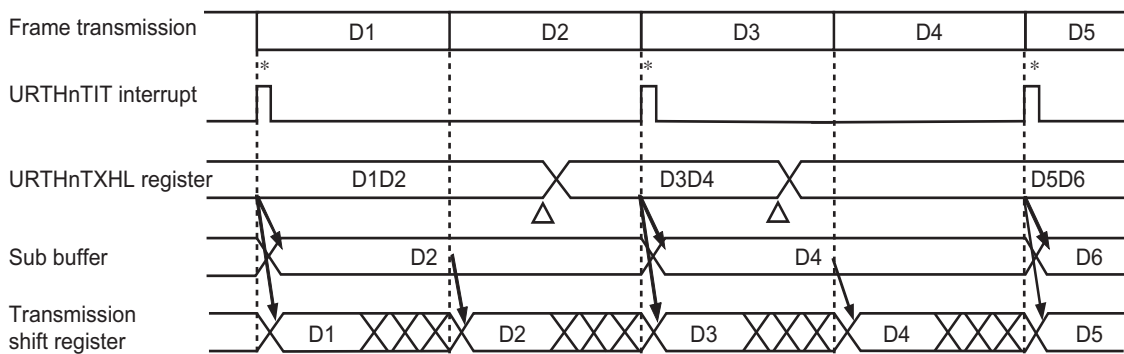

Note * A transmission enable interrupt is generated if the transmit data register is empty.

Caution In the consecutive two-frame transfer, the transmit data register is only accessible in 16-bit units. Do not write to this register in 8-bit units.

(c) Timing of consecutive two-frame transmission (when URTHnCTL1.URTHnSLIT = 1)

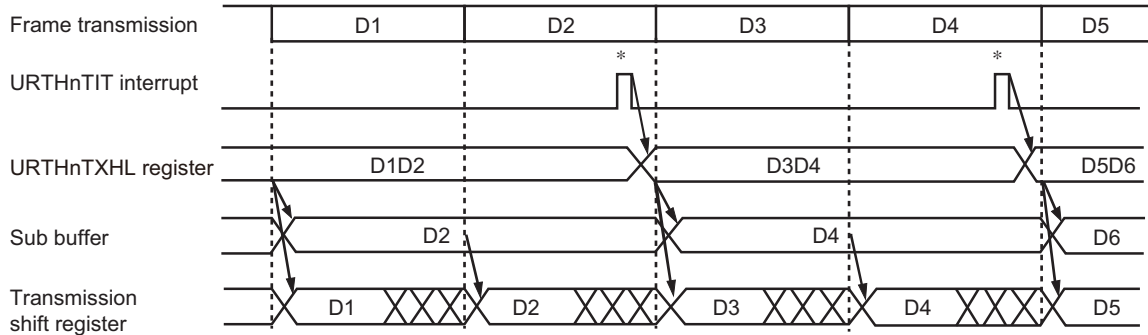

Note * A transmission enable interrupt is generated at the end of transmission.

Caution In the consecutive two-frame transfer, the transmit data register is only accessible in 16-bit units. Do not write to this register in 8-bit units.

(d) Timing of consecutive two-frame reception

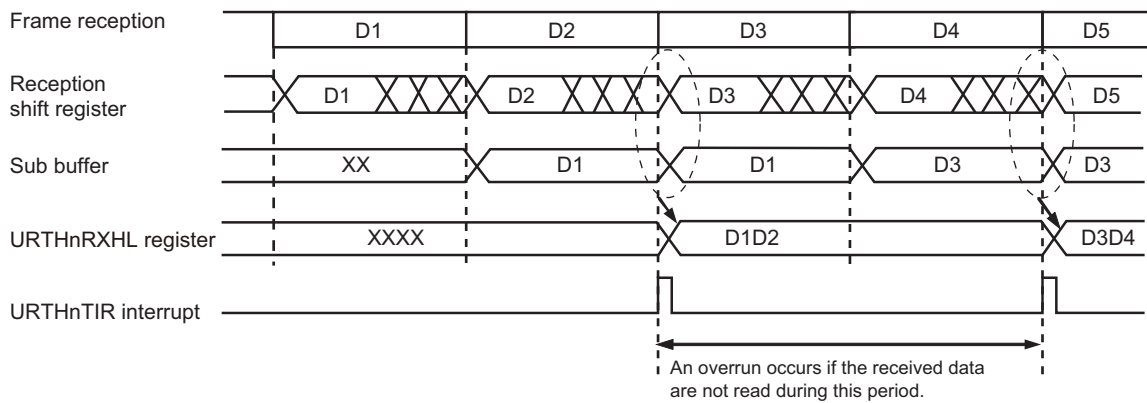

Caution In the consecutive two-frame transfer, the transmit data register is only accessible in 16-bit units. Do not write to this register in 8-bit units.

22.6.5 Extension bit Detection/ID Compare-Match Detection

For extension bit detection, the extension bit is enabled (URTHnOPT0.URTHnEBE = 1) and extension bit detection interrupts are enabled (URTHnOPT0.URTHnEGE = 1). On detection of an extension bit during reception, an extension bit detection interrupt is generated if the condition for extension bit detection set in URTHnOPT0.URTHnEJL is matched and the extension bit detection flag (URTHnSTR1.URTHnEBD) is set to 1.

The extension bit detection flag (URTHnSTR1.URTHnEBD) is set to 1 when the extension bit is 0 if the setting of the condition for extension bit detection is URTHnOPT0.URTHnEJL=0 (URTHnOPT1.URTHnIDCN = 0) and when the extension bit is 1 if the setting is URTHnOPT0.URTHnEJL = 1 (URTHnOPT1.URTHnIDCN = 0) (however, if ID comparison is selected as a condition, i.e. if URTHnOPT1.URTHnIDCN = 1, the extension bit will only be detected if ID comparison also produces a match).

URTHnSTR1.URTHnEBD is cleared when 1 is written to URTHnSTC.URTHnCLEB.

When the ID and settings for ID comparison match while ID matching is selected as a condition (URTHnOPT1.URTHnIDCN = 1), URTHnSTR1.URTHnIDM is set to 1. When an extension bit is detected and the ID matches the settings for ID comparison in extension bit detection while URTHnOPT1.URTHnIDCN = 1, the ID comparison match flag is set to URTHnSTR1.URTHnIDM = 1, which enables data reception. Data are not received if the ID does not match the settings for ID comparison. Moreover, bits for which the corresponding URTHnOPT2.URTHnMID[7:0] bit is 1 are not included in ID comparison (i.e. these bits are masked).

URTHnSTR1.URTHnIDM is cleared when 1 is written to URTHnSTC.URTHnCLIM.

(a) Timing of extension bit detection and ID compare-match detection

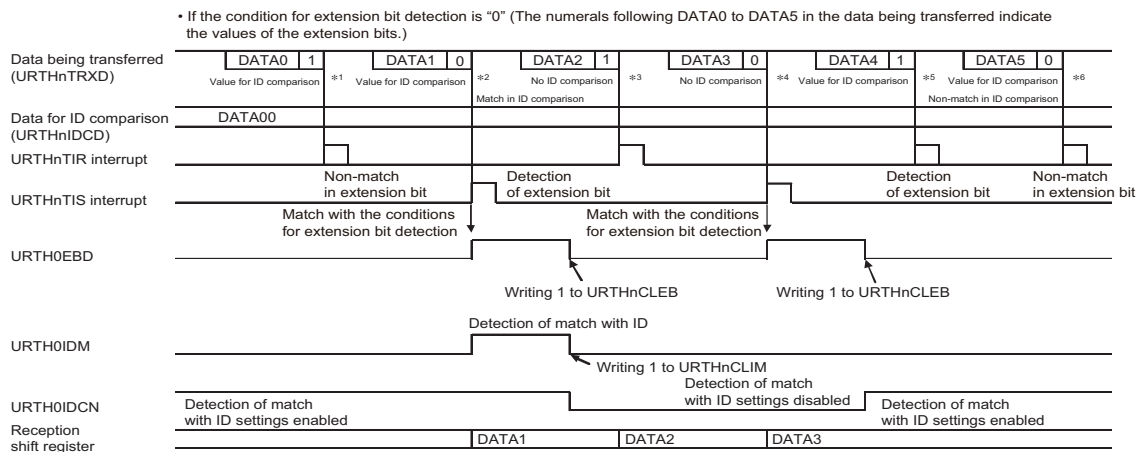

- Note 1. Extension bit detection and ID comparison are enabled (URTHnOPT1.URTHnIDCN = 1) during the transfer of DATA0. The level of the extension bit differs from the detection condition, so neither a reception interrupt (URTHnTIR) nor a status interrupt (URTHnTIS) is generated.
- Note 2. Extension bit detection and ID comparison are enabled (URTHnOPT1.URTHnIDCN = 1) during the transfer of DATA1. The level of the extension bit and the ID match the respective detection conditions, so a status interrupt (URTHnTIS) is generated.
- Note 3. In DATA2, data are being received because the ID was matched in DATA1. ID comparison is disabled (URTHnOPT1.URTHnIDCN = 0) and so will not proceed. A reception interrupt (URTHnTIR) is generated in response to the correct reception of DATA2.
- Note 4. Extension bit detection and ID comparison are disabled (URTHnOPT1.URTHnIDCN = 0) during the transfer of DATA3, but the level of the extension bit matches the detection condition, so a status interrupt (URTHnTIS) is generated.
- Note 5. Extension bit detection and ID comparison are enabled (URTHnOPT1.URTHnIDCN = 1) during the transfer of DATA4, and the level of the extension bit does not match the detection condition, so neither a reception interrupt (URTHnTIR) nor a status interrupt (URTHnTIS) is generated.
- Note 6. Extension bit detection and ID comparison are enabled (URTHnOPT1.URTHnIDCN = 1) during the transfer of DATA5. The level of the extension bit matches the detection condition but the ID does not, so neither a reception interrupt (URTHnTIR) nor a status interrupt (URTHnTIS) is generated.
-
- Caution 1. If a reception error (parity, framing, or overrun error) had occurred during the reception of DATA2, the error flag would have been set and a status interrupt request (URTHnTIS) generated instead of a reception completed interrupt request (URTHnTIR).
- Caution 2. If a reception error (parity, framing or overrun error) had occurred during the reception of DATA1 and DATA3, the error flag would have been set (along with URTHnIDM or URTH0EBD). If a reception error occurred during DATA0, DATA4, or DATA5, the error flag would not have been set.
-

22.6.6 BF Transmission/Reception Format

The UARTHn has an BF (break field) transmission/reception control function to enable use of the LIN function.

About LIN LIN stands for Local Interconnect Network and is a low-speed (1 to 20 kbps) serial communication protocol intended to aid the cost reduction of an automotive network.

LIN communication is single-master communication, and up to 15 slaves can be connected to one master.

The LIN slaves are used to control the switches, actuators, and sensors, and these are connected to the LIN master via the LIN network.

Normally, the LIN master is connected to a network such as CAN (Controller Area Network).

In addition, the LIN bus uses a single-wire method and is connected to the nodes via a transceiver that complies with ISO9141.

In the LIN protocol, the master transmits a frame with baud-rate information and the slave receives it and corrects the baud-rate error. Therefore, communications are possible when the baud-rate error of the slave is $\pm 14\%$ or less.

For an outline of LIN transmission and reception, refer to Figure 22-5, LIN Transmission in Outline, and Figure 22-6, LIN Reception in Outline.

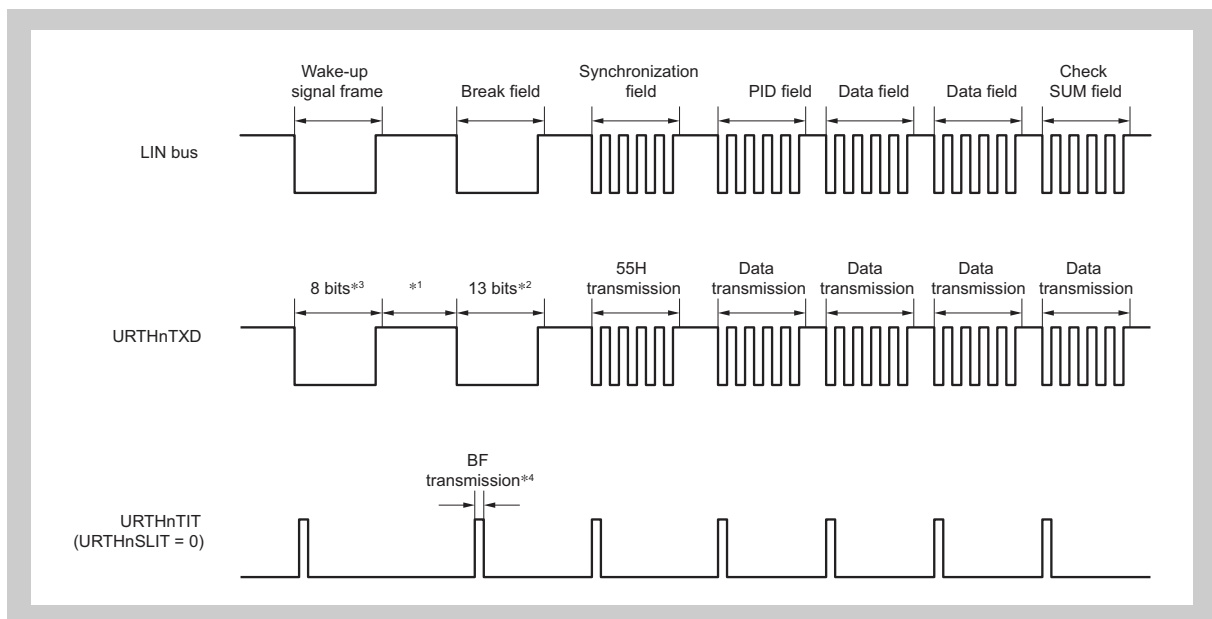

Figure 22-5 LIN Transmission in Outline

- Note 1. The interval between each field is controlled by software.
- Note 2. BF output is performed by hardware. The output width is the bit length set by URTHnCTL1.URTHnBLG[2:0]. If even finer output width adjustments are required, such adjustments can be performed using URTHnCTL2.URTHnBRS[11:0].
- Note 3. 80_H transfer in the 8-bit mode is substituted for the wakeup signal frame.
- Note 4. A transmission enable interrupt URTHnTIT is generated at the start of each transmission. URTHnTIT is also generated at the start of each BF transmission.

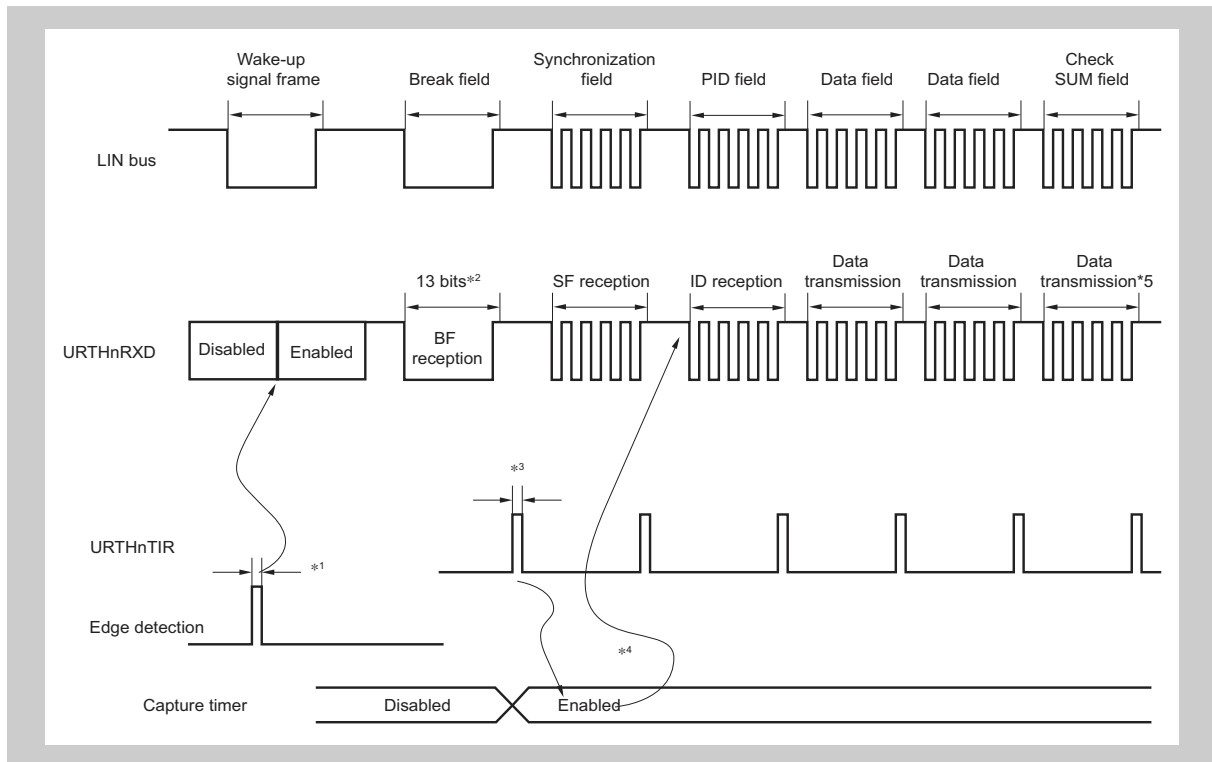

Figure 22-6 LIN Reception in Outline

- Note 1. The wakeup signal is sent by the edge detector for the pin, the UARTHn is enabled, and the BF reception mode is set.
- Note 2. BF reception is judged to have ended normally upon detection of 11 or more BF bits.

An interrupt is generated as follows in accord with the setting of the BF reception mode selection bit (URTHnCTL1.URTHnSLBM):

- a reception interrupt (URTHnTIR) is generated if URTHnCTL1.URTHnSLBM is set to "0", and
- a status interrupt (URTHnTIS) is generated if URTHnCTL1.URTHnSLBM is set to "1".

Upon detection of BF reception of less than 11 bits, an BF reception error is judged, no interrupt is generated, and the mode returns to the BF reception mode.

- Note 3. An interrupt is generated as follows in accord with the setting of the BF reception mode selection bit (URTHnCTL1.URTHnSLBM) on the normal completion of BF reception:

- a reception interrupt (URTHnTIR) is generated if URTHnCTL1.URTHnSLBM is set to "0", and
- a status interrupt (URTHnTIS) is generated and the BF reception success flag (URTHnSTR1.URTHnBSF) is set if URTHnCTL1.URTHnSLBM is set to "1".

If the BF reception trigger bit URTHnTRG.URTHnBRT = 1, overrun, parity, and framing errors are not detecting during reception of the BF. Moreover, data are not transferred from the reception shift register to the receive data register URTHnRX. At that time, the URTHnRX retains its prior value.

- Note 4. In order to adjust the baud-rate clock properly, the URTHnRXD signal needs to be connected to the capture input of a timer. (For details, refer to Section 22.8, Detecting the Baud Rate in LIN Communications as a Slave.) The transfer rate and baud-rate error can be calculated from the measured time between two edges of the URTHnRXD signal, and the baud rate can be adjusted accordingly via the baud-rate setting bits (URTHnCTL2.URTHnBRS[11:0]).
- Note 5. The check-sum field is distinguished by software. UARTHn is initialized following reception of the check-sum field, and processing to set the BF reception mode again is performed by software. When URTHnCTL1.URTHnSLBM = 1, BF can be received.

22.6.7 BF Transmission

Setting both the URTHnPW and URTHnTXE bits in URTHnCTL0 to 1 places the interface in the transmission enabled state, after which BF transmission is started by setting the BF transmission trigger (URTHnTRG.URTHnBTT) to 1.

Thereafter, URTHnSTR0.URTHnSSBT is set to "1" and the low level is output over a width of 13 to 20 bits, as specified by URTHnCTL1.URTHnBLG[2:0].

A transmission interrupt URTHnTIT is generated

- at the start of BF transmission if URTHnCTL1.URTHnSLIT = 0 and
- at the end of BF transmission if URTHnCTL1.URTHnSLIT = 1.

Following the end of BF transmission, URTHnSTR0.URTHnSSBT is automatically cleared. Thereafter, the UARTHn transmission mode is restored.

Transmission is suspended until the next data for transmission are written to the URTHnTX register, or until the BF transmission trigger (URTHnTRG.URTHnBTT) is set to 1 and URTHnSTR0.URTHnSSBT changes to 1.

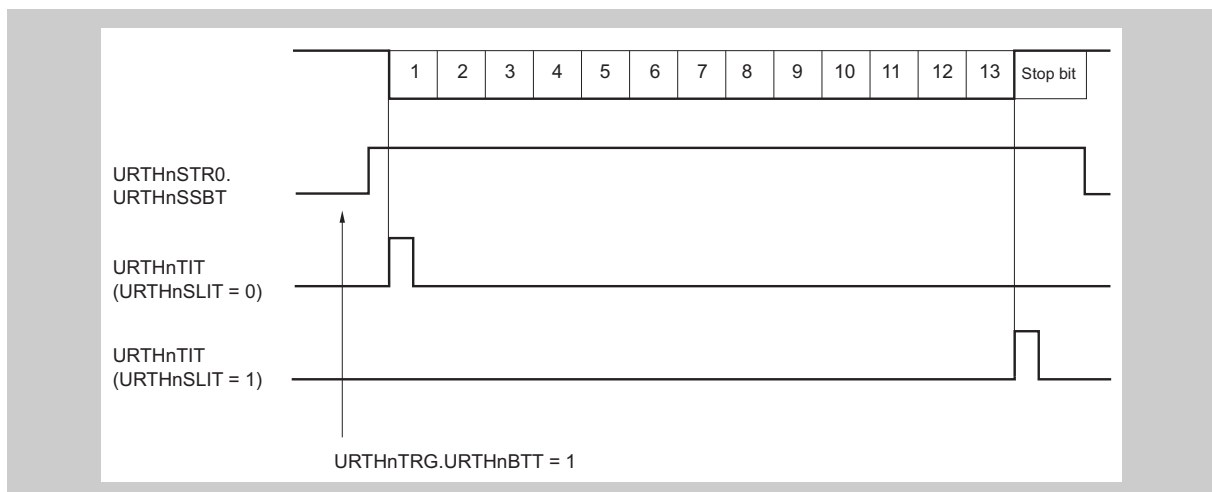

Figure 22-7 BF Transmission

22.6.8 BF Reception

The reception enabled status is achieved by setting the URTHnCTL0.URTHnPW bit to 1 and then setting the URTHnCTL0.URTHnRXE bit to 1.

The state of waiting for BF reception is set by setting the BF reception trigger (URTHnTRG.URTHnBRT) to 1.

In the BF reception wait status, similarly to the UARTHn reception wait status, the URTHnRXD pin is monitored and start bit detection is performed.

Following detection of the low level, reception is started and the internal counter counts up according to the set baud rate.

When a high level is received over at least 11 bit intervals (i.e. valid BF reception), the response depends on the value of the BF reception mode selection bit.

- A reception interrupt (URTHnTIR) is generated if URTHnCTL1.URTHnSLBM = 0.
- A status interrupt (URTHnTIS) is generated and the BF reception success flag (URTHnSTR1.URTHnBSF) is set if URTHnCTL1.URTHnSLBM = 1.

The URTHnSTR0.URTHnSSBR bit is automatically cleared and BF reception ends.

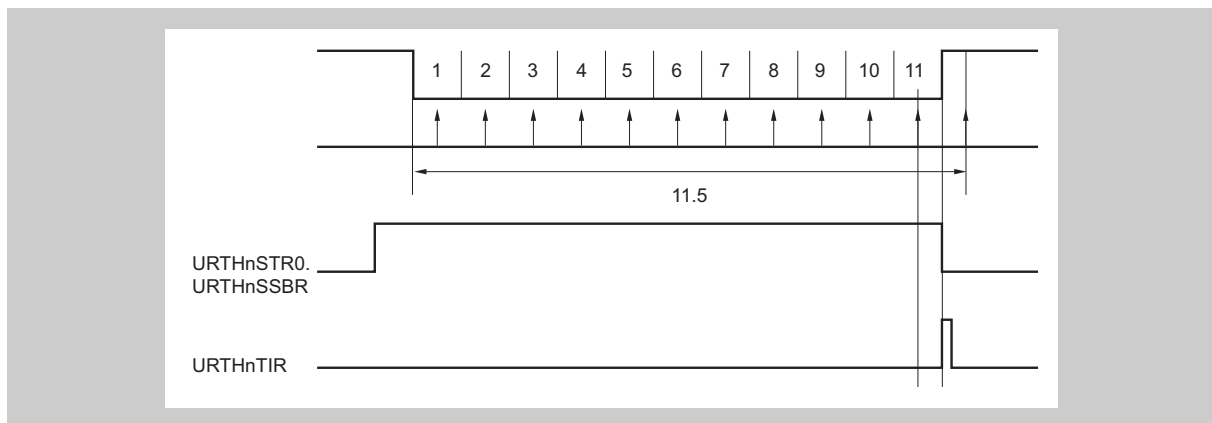

Figure 22-8 Normal BF Reception (Detection as Stop Bits After 10.5 Bits at the Low Level)

Error detection for the URTHnSTR1 error flags URTHnOVE, URTHnPE, and URTHnFE is suppressed and UARTHn communication error detection processing is not performed.

Moreover, the received data are not stored in URTHnRX.

If the BF width is 10 or fewer bits, reception is terminated as error processing without generating an interrupt, and the mode returns to the BF reception mode. URTHnSTR0.URTHnSSBR is not cleared at this time.

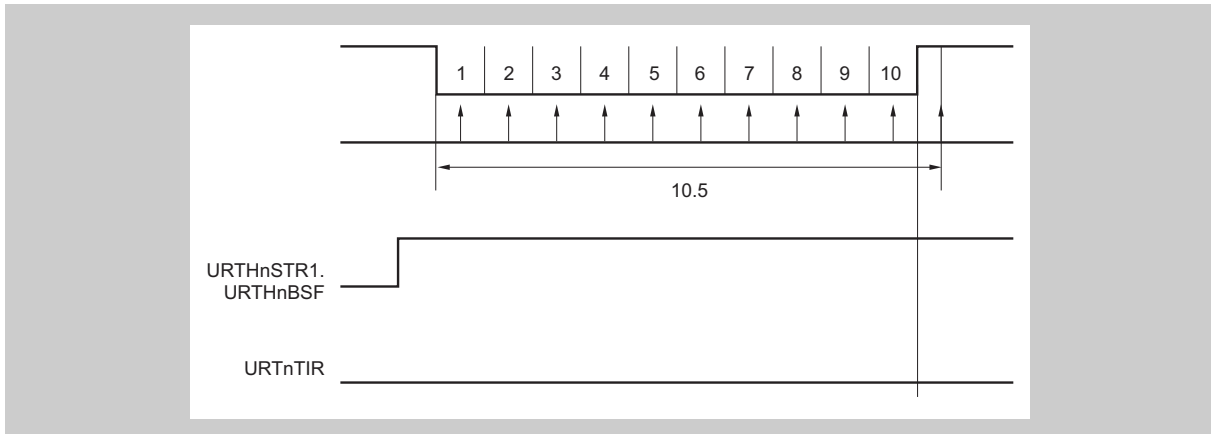

Figure 22-9 Error in BF Reception (Detection as Stop Bits within 10.5 Bits at the Low Level)

The URTHnSTR1.URTHnBSF bit indicates the state of successful reception of the BF.

Note URTHnSTR0.URTHnSSBR is set to "1"

- by setting URTHnTRG.URTHnBRT to "1" and
- is cleared by normal BF reception.

22.6.9 Transmission Data Consistency Check

The UARTHn incorporates a data consistency checking function to detect mismatches between data transmitted as the URTHnTXD signal and data received as the URTHnRXD signal while the device is operating with transmission enabled.

Data consistency check is enabled by $\text{URTHnCTL0.URTHnSLDC} = 1$.

The data consistency is checked by comparing the transmit data in the transmit register URTHnTX and the received data in the receive register URTHnRX. In case of a mismatch the data consistency error flag URTHnSTR1.URTHnDCE is set and a status interrupt request URTHnTIS is generated.

Data are not checked for consistency while transmission is suspended.

Consistency between the levels of the transmitted data and of the input data is checked even if reception is disabled during transmission. In this case, the receive completion interrupt request signal URTHnTIR does not occur, and status bits of URTHnSTR1 (URTHnBSF, URTHnFE and URTHnOVE) are not set either, but when a consistency error occurs, the status interrupt request signal URTHnTIS is generated and the status bit (URTHnDCE) of URTHnSTR1 is set. Received data does not need to be read.

For details, refer to Section 22.4, (6) URTHnSTR1 – UARTHn Status Register 1.

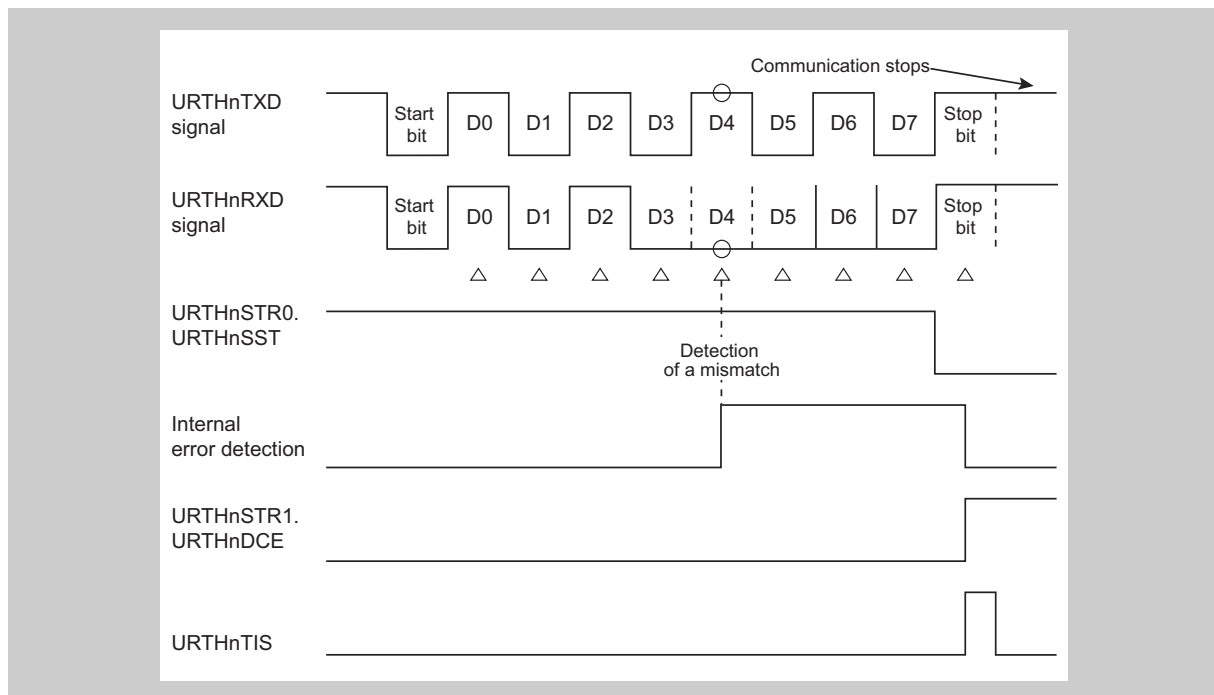

Figure 22-10 Timing Example of Data Consistency Error (No BF Reception Active, i.e. $\text{URTHnSTR0.URTHnSSBR} = 0$)

22.6.10 UARTHn Transmission

Transmission start Set the transmission enabled status by performing the following procedures.

- Specify the baud rate by the UARTHn control register 2 (URTHnCTL2).
- Specify the transmit parity, data character length, stop bit length, transmit data order, transmission interrupt request timing and output logic level by the UARTHn control register 1 (URTHnCTL1).
- Enable UARTHn operation and transmission by setting $URTHnCTL0.URTHnPW = URTHnCTL0.URTHnTXE = 1$.

Writing of the data for transmission to the transmission buffer register URTHnTX causes transmission to start. Once saved in the URTHnTX register, the data are transferred to the transmission shift register. After that, the start, parity and stop bits are included in the data frame, which is then output serially via URTHnTXD.

Transmission stop When URTHnCTL0.URTHnPW or URTHnCTL0.URTHnTXE is set to 0, transmission operations are stopped immediately, even during transmission processing.

Concurrent BF and data transmission When a BF transmit request and a data transmit request have both been set, BF transmission takes priority.

Data consistency check On detection of a data consistency error, further data are not transmitted until $URTHnSTC.URTHnCLDC = 1$, $URTHnCTL0.URTHnPW = 0$, or $URTHnCTL0.URTHnTXE = 0$ is written. (After an error is detected, follow the procedure described in Section 22.4, (1) URTHnCTL0 – UARTHn Control Register 0, under Caution 1 and Caution 2.)

URTHnTIT timing The time to generate the transmission interrupt URTHnTIT depends on the setting of the URTHnCTL1.URTHnSLIT bit:

- If $URTHnCTL1.URTHnSLIT = 0$, URTHnTIT is generated at the start of transmission, i.e. when the data from the data register (URTHnTX) are transferred to the transmission shift register.
- If $URTHnCTL1.URTHnSLIT = 1$, URTHnTIT is generated on completion of the entire data transmission process, i.e. when the last bit of the data frame has been transmitted.

Once URTHnTIT is generated, the next data can be written to URTHnTX.

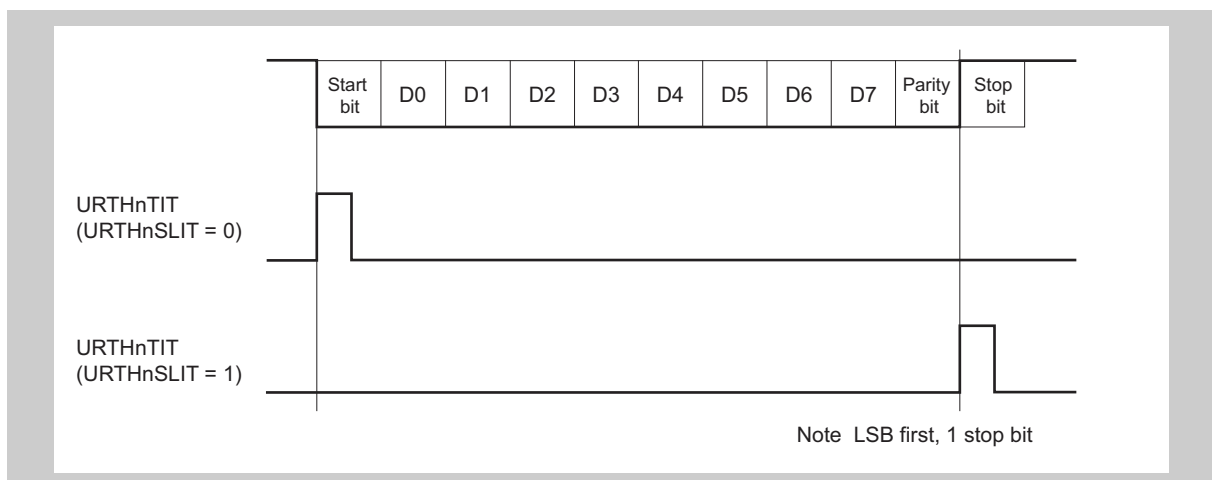

Figure 22-11 Transmission Interrupt Timing

22.6.11 Continuous Transmission Procedure

Continuous transmission is achieved by setting $URTHnCTL1.URTHnSLIT = 0$, using the $URTHnTIT$ interrupt to confirm the timing with which data for transmission that have been written to the $URTHnTX$ register are transferred to the transmission shift register, and then writing the next data for transmission to the data register while data transmission is in progress.

Caution If a value is written to the $URTHnTX$ register before the $URTHnTIT$ is generated, previously set data for transmission are overwritten by the new data.
To initialize the transmission unit (by setting $URTHnTXE = 0$ or $URTHnPWR = 0$), confirm that no transmission is ongoing (i.e. that $URTHnSTR0.URTHnSSBT = URTHnSST = 0$). Initialization while transmission is ongoing leads to transmission being aborted.

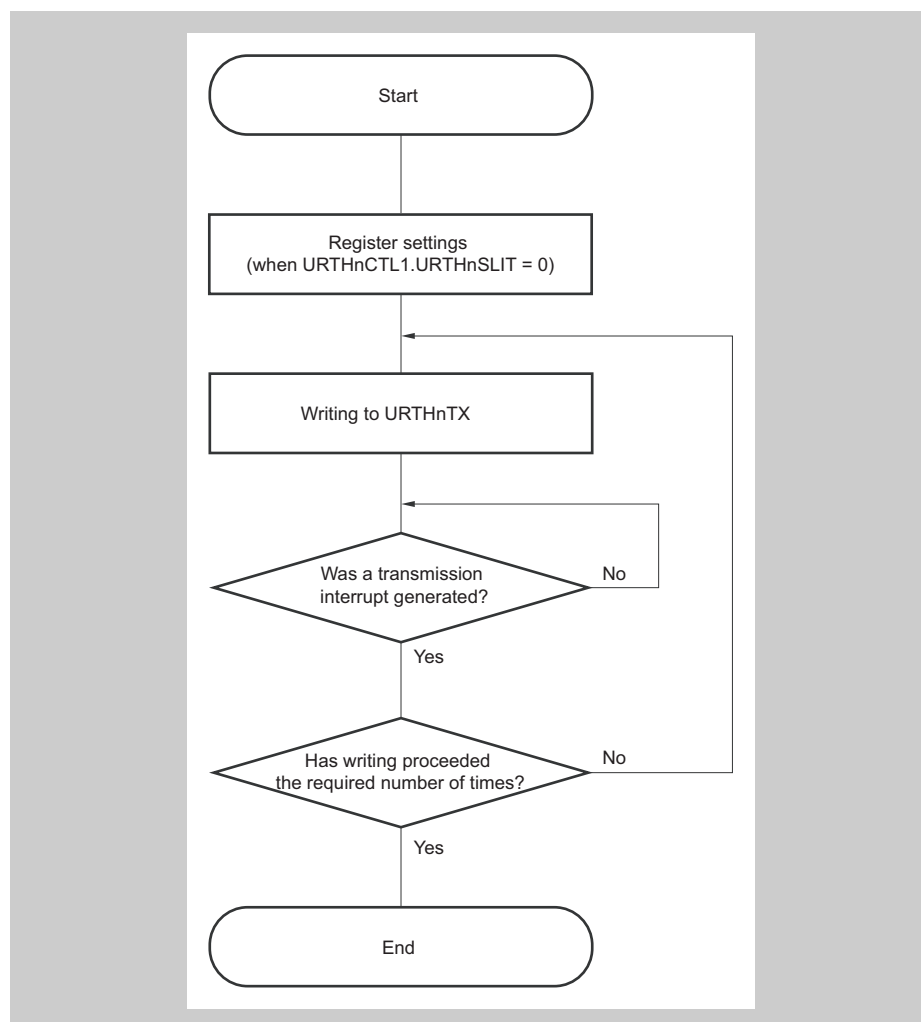

Figure 22-12 Continuous Transmission Processing Flow

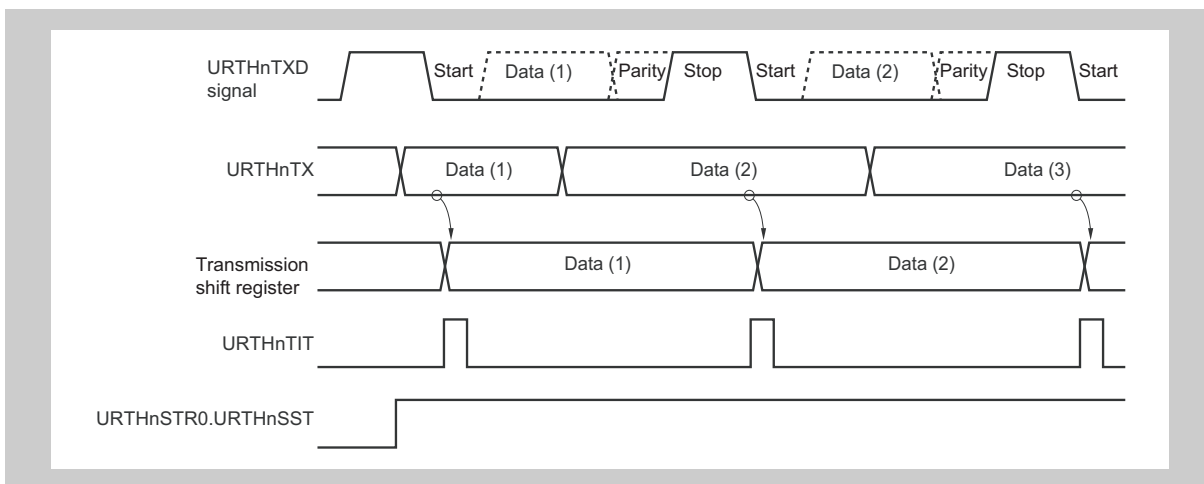

Figure 22-13 Continuous Transmission Operation Timing (Transmission Start)

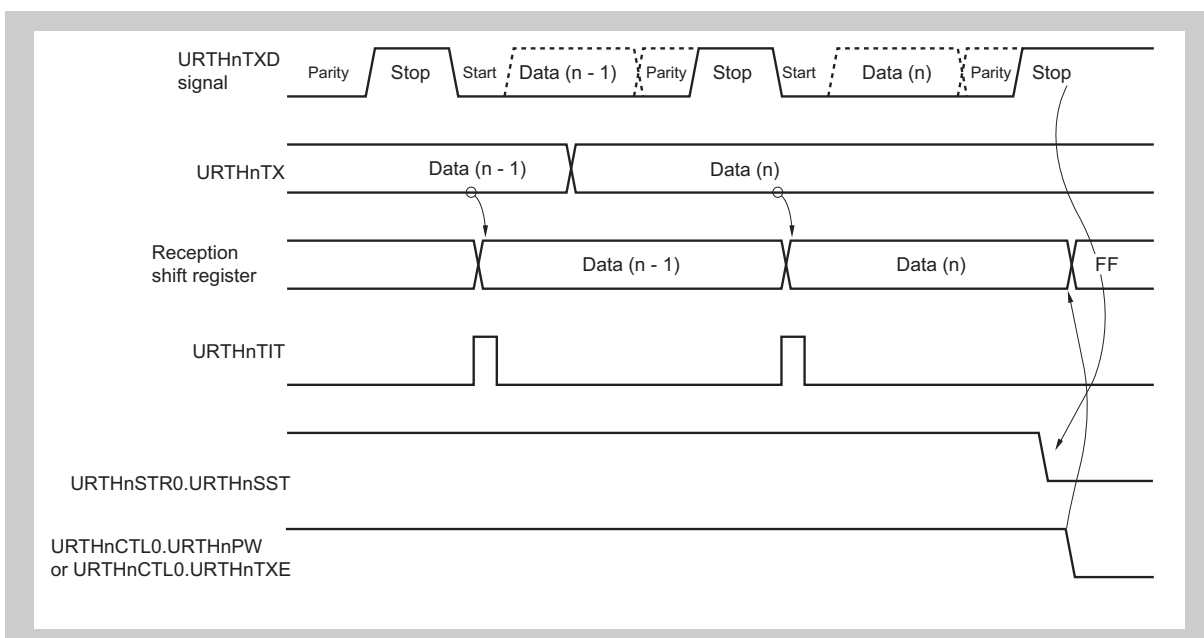

Figure 22-14 Continuous Transmission Operation Timing (Transmission End)

22.6.12 UARTHn reception

- Reception start** Set the reception enabled status by the following procedure:
- Specify the baud rate by the UARTHn control register 2 (URTHnCTL2).
 - Specify the receive parity, data character length, receive data order, and output logic level of receive data by the UARTHn control register 1 (URTHnCTL1).
 - Enable UARTHn operation and reception by setting $URTHnCTL0.URTHnPW = URTHnCTL0.URTHnRXE = 1$.

When the sampling of the input level of the URTHnTRXD pin is performed and the falling edge is detected, the data sampling of the URTHnRXD input is started.

The start bit is recognized if the URTHnRXD pin is low level after the time of a half bit is passed after the detection of the falling edge (shown in the figure below).

After a start bit has been recognized, the receive operation starts, and serial data are stored in the reception shift register according to the set baud rate. When the reception interrupt URTHnTIR is asserted upon reception of the stop bit, the data stored in the reception shift register are written to the receive data register (URTHnRX).

- Reception stop** When URTHnCTL0.URTHnPW or URTHnCTL0.URTHnRXE is set to 0, reception operations are stopped immediately, even during reception processing.

- Reception errors** If an overrun error occurs ($URTHnSTR1.URTHnOVE = 1$), the receive data at this time is not transferred to the URTHnRX register and is discarded.

Even if a parity error ($URTHnSTR1.URTHnPE = 1$) occurs during reception, reception continues until the stop bit, and the reception data are transferred to the RX register. And, a framing error ($URTHnSTR1.URTHnFE = 1$) is judged at the stop bit position, and even if an error is detected, the received date is transferred to the URTHnRX register.

An error in reception in this case leads to generation of the status interrupt (URTHnTIS) instead of the reception interrupt (URTHnTIR).

Clear the power bit to 0 ($URTHnCTL0.URTHnPW = 0$) before changing the order of data reception, parity, character length, or logic level of receive data.

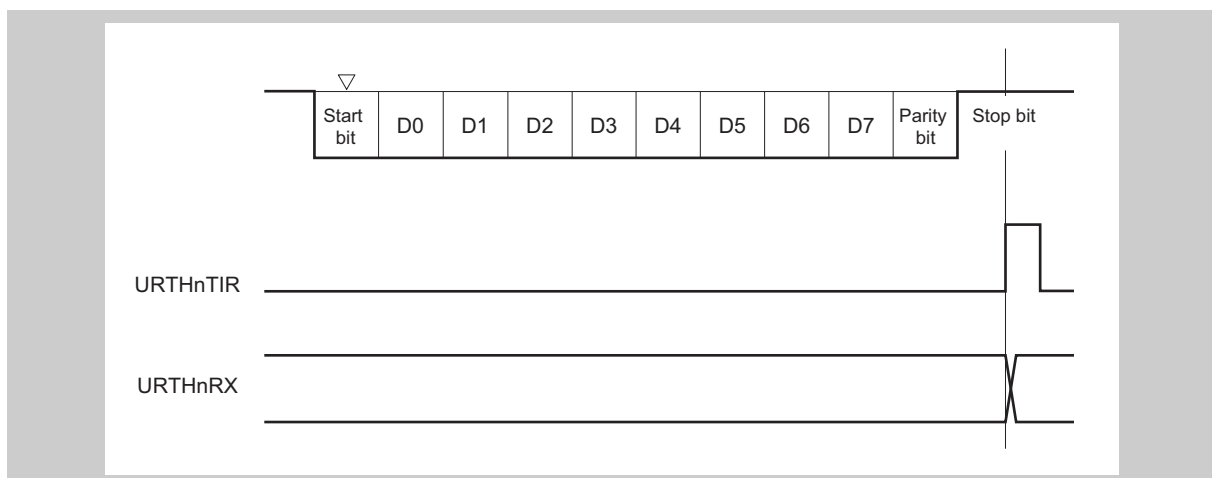

Figure 22-15 UARTHn Reception

- Caution 1. Be sure to read the URTHnRX register even when a reception error occurs. If the URTHnRX register is not read, an overrun error occurs during reception of the next data.
- Caution 2. The operation during reception is performed assuming that there is only one stop bit. A second stop bit is ignored.
- Caution 3. When trying to reduce current flow by stopping the unit on completion of reception, read the URTHnRX register after the reception interrupt URTHnTIR has been generated, and then clear the URTHnCTL0.URTHnPW or URTHnCTL0.URTHnRXE bit to 0. If the URTHnCTL0.URTHnPW or URTHnCTL0.URTHnRXE bit is cleared to 0 before the URTHnTIR is generated, the value read from the URTHnRX register cannot be guaranteed.
- Caution 4. If processing to indicate completion of reception (generation of the URTHnTIR interrupt) and clearing of the URTHnCTL0.URTHnPW or URTHnCTL0.URTHnRXE bit to 0 occur simultaneously, the URTHnTIR may still be generated despite the URTHnRX register holding no data.
-

- Note 1. When URTHnCTL0.URTHnPW/URTHnCTL0.URTHnRXE is changed from 0 to 1 while URTHnRXD pin is set to 0, it is not judged as the start bit, because falling edges are not detected.
- Note 2. In continuous reception, the subsequent start bit may be detected immediately after the stop bit (in response to which the reception interrupt is generated).

22.6.13 Reception Errors

Errors during a receive operation are of 3 types: parity errors, framing errors, and overrun errors. Data reception result error flags are set in the URTHnSTR1 register and a status interrupt request signal URTHnTIS is generated when an error occurs.

It is possible to ascertain which error occurred during reception by reading the contents of the URTHnSTR1 register.

Clear a reception error flag by writing 1 to its associated bit in the status clear register URTHnSTC.

Table 22-30 Sources of Reception Errors

Error Flag in URTHnSTR1	Reception Error	Source
URTHnPE	Parity error	Received parity bit does not match the setting
URTHnFE	Framing error	Stop bit is not detected
URTHnOVE	Overrun error	Reception of next data completed before data was read from receive buffer

Note Even in case of a parity or framing error, data are transferred from the reception shift register to the receive data register URTHnRX. Consequently the data from URTHnRX must be read. Otherwise an overrun error (URTHnSTR1.URTHnOVE = 1) will occur when reception of the next data is completed.

In case of an overrun error, data in the reception shift register are not transferred to the URTHnRX register, so the previous data are not overwritten.

22.6.14 Parity Types and Operations

Caution When using the LIN function, fix the URTHnCTL1.URTHnSLP[1:0] to 00_B.

The parity bit is used to detect bit errors in the communication data. In general, use the same parity on both sides (transmission and reception).

(1) Even Parity

- During transmission

The parity bit is controlled so that the number of bits with the value "1" among the data is even. The values of the parity bit are as follows.

- Odd number of bits having the value "1" among those for transmission: 1
- Even number of bits having the value "1" among those for transmission: 0

- During reception

The number of bits having the value "1" among the received data, including the parity bit, is counted. An odd result produces a parity error.

(2) Odd parity

- During transmission

In the opposite way to even parity, the parity bit is controlled so that the number of bits having the value "1" among the data is odd. The values of the parity bit are as follows.

- Odd number of bits having the value "1" among those for transmission: 0
- Even number of bits having the value "1" among those for transmission: 1

- During reception

The number of bits having the value "1" among the received data, including the parity bit, is counted. An even result produces a parity error.

(3) 0 Parity

During transmission, the parity bit is always made 0, regardless of the transmit data.

During reception, parity bit check is not performed. Therefore, no parity error occurs, regardless of whether the parity bit is 0 or 1.

(4) No parity

No parity bit is added to the transmit data.

Reception is performed assuming that there is no parity bit. No parity error occurs since there is no parity bit.

22.6.15 Digital Receive Data Noise Filter

Each of the input pins for data reception signals (URTHnTRXD, URTHnSC, and URTHnCTS) is equipped with a digital noise filter for eliminating noise and spikes.

A filter samples the signal on the URTHnRXD, URTHnSC, or URTHnCTS pin with the prescaler output clock (PRSCLK) as the sampling clock.

When the same sampling value is read twice, the signal of each pin is validated as the input data.

Therefore, data not exceeding the width of 2 prescaler output clocks is judged to be noise and thus eliminated.

The noise filter leads to a delay of 4 cycles of the clock signal output by the prescaler (PRSCLK) from capture of each serial bit until it is forwarded as valid.

The noise filter circuit runs when reception is enabled (URTH0PW = URTH0RXE = 1) and in processing for transmission with transmission and data consistency error checking enabled (URTH0PW = URTH0TXE = URTH0SLDC = 1).

22.7 Baud-Rate Generator

The transmission and reception baud-rate clocks (BRCLK) are derived from the PCLK by using a prescaler and a baud-rate generator (refer to the figure below).

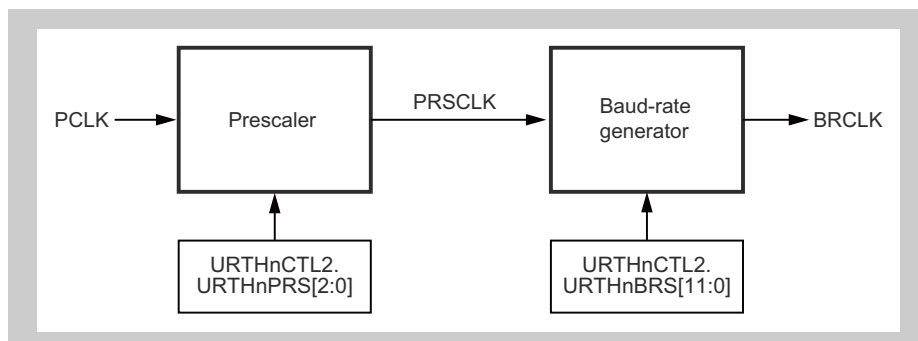

Figure 22-16 Configuration of a Baud-Rate Generator

The prescaler output clock PRSCLK is at a fraction of the frequency of PCLK. The setting of URTHnCTL2.URTHnPRS[2:0] determines the denominator of this fraction.

$$PRSCLK = PCLK / 2^{URTHnPRS[2:0]}$$

PRSCLK is further divided by the baud-rate generator by a value, determined by URTHnCTL2.URTHnBRS[11:0].

The baud-rate generator distinguishes between the baud rate for data frames and BF receptions, as listed in the table below. The BF reception clock is the double of the baud-rate clock BRCLK.

Table 22-31 Baud-Rate Generator Clocks Output

URTHnCTL2.URTHnBRS[11:0]	Transmit/Receive BRCLK	BF Receive Clock
000 _H	PRSCLK/(2 × 2)	PRSCLK/2
001 _H		
002 _H		
003 _H	PRSCLK/(2 × 3)	PRSCLK/3
004 _H	PRSCLK/(2 × 4)	PRSCLK × 4
005 _H	PRSCLK/(2 × 5)	PRSCLK × 5
...	PRSCLK/(2 × URTHnBRS[11:0])	PRSCLK/URTHnBRS[11:0]
FFE _H	PRSCLK/(2 × 4094)	PRSCLK/4094
FFF _H	PRSCLK/(2 × 4095)	PRSCLK/4095

22.8 Detecting the Baud Rate in LIN Communications as a Slave

This product has a facility for input from the serial data input pins to TAUB0. Using this function leads to activation of the detection of baud rates in LIN communications as a slave.

Note the following points when using this facility.

- Use TAUB0 in an operating mode in which baud-rate detection is possible.
- Do not change the settings of the ICOREG0 register while the timer is in operation.
- Do not use this function to connect a serial data input pin to TAUB0 for any purpose other than detecting the baud rate in LIN communications.

Section 23 A/D Converter

23.1 ADCA Features

This product incorporates the A/D converter (ADC).

Specifications are given in the following table.

ADC		Product	μ PD70F4154 μ PD70F4155
		Instance (represented by n)	
Number of analog input pins (represented by m)		18 (m = 1 to 18)	
Number of channel groups (represented by i)		3 (i = 0 to 2)	
Register base address	<ADCA _n _base0>* ¹		FF81 D000 _H
	<ADCA _n _base1>* ¹		FFFF DC00 _H
Resolution		10 or 12 bits	
Conversion result check		Available	
Discharge		Available	
Hardware trigger expansion		Available	
Channel sample and hold (represented by x)		6 (x = 1 to 6) Corresponds to m = 1 to 6	
Supplied clock		PCLK	

Note 1. All the register addresses related to the A/D converter that are described in this section are defined as address offsets from the base addresses given in the above table.

Caution Undefined bits should be used with the initial value settings.

The following table shows the unit to which each signal is connected.

Table 23-1 ADCA_n Interrupt Requests

Signal Name	Function	Connected to	
		Unit	Signal
INTADCA0Ti	A/D conversion end interrupt for CGi	Interrupt controller, DMA	INTADCA0li
INTADCA0LLT	Latest conversion latch and timing signal	Interrupt controller	INTADCA0LLT
INTADCA0TERR	Error interrupt	Interrupt controller, DMA	INTADCA0ERR

This product has the hardware trigger function. The following table shows the units to which the hardware trigger signals ADCAnTRGi for CGi are connected.

Table 23-2 Units to which Hardware Trigger Signals are Connected (1/2)

ADCAn Channel Group	Trigger Input Signal			ADCAn Trigger Signal
	Name	Connected to		
		Unit	Signal	
CG0	ADCA0TTIN000	PIC	ADOPA0ADCATTIN00	ADCA0TTRG0
	ADCA0TTIN001	Not connected	–	
	ADCA0TTIN002	ENCA0	INTENCA0I1	
	ADCA0TTIN003	Not connected	–	
	ADCA0TTIN004	TSG20	TS0ADTRG0	
	ADCA0TTIN005	TSG20	TS0ADTRG1	
	ADCA0TTIN006	Not connected	–	
	ADCA0TTIN007	Not connected	–	
	ADCA0TTIN008	Port	ADCA0TRG0	
	ADCA0TTIN009	Not connected	–	
	ADCA0TTIN010	Not connected	–	
	ADCA0TTIN011	Not connected	–	
	ADCA0TTIN012	Not connected	–	
	ADCA0TTIN013	Not connected	–	
	ADCA0TTIN014	Not connected	–	
ADCA0TTIN015	Not connected	–		
CG1	ADCA0TTIN100	PIC	ADOPA1ADCATTIN00	ADCA0TTRG1
	ADCA0TTIN101	Not connected	–	
	ADCA0TTIN102	ENCA0	INTENCA0I1	
	ADCA0TTIN103	Not connected	–	
	ADCA0TTIN104	TSG20	TS0ADTRG0	
	ADCA0TTIN105	TSG20	TS0ADTRG1	
	ADCA0TTIN106	Not connected	–	
	ADCA0TTIN107	Not connected	–	
	ADCA0TTIN108	Port	ADCA0TRG1	
	ADCA0TTIN109	TAPA0	TAPA0TADOUT0	
	ADCA0TTIN110	Not connected	–	
	ADCA0TTIN111	Not connected	–	
	ADCA0TTIN112	Not connected	–	
	ADCA0TTIN113	Not connected	–	
	ADCA0TTIN114	Not connected	–	
ADCA0TTIN115	Not connected	–		

Table 23-2 Units to which Hardware Trigger Signals are Connected (2/2)

ADCAn Channel Group	Trigger Input Signal			ADCAn Trigger Signal
	Name	Connected to		
		Unit	Signal	
CG2	ADCA0TTIN200	PIC	ADOPA2ADCATTIN00	ADCA0TTRG2
	ADCA0TTIN201	Not connected	—	
	ADCA0TTIN202	ENCA0	INTENCA0I1	
	ADCA0TTIN203	Not connected	—	
	ADCA0TTIN204	TSG20	TS0ADTRG0	
	ADCA0TTIN205	TSG20	TS0ADTRG1	
	ADCA0TTIN206	Not connected	—	
	ADCA0TTIN207	Not connected	—	
	ADCA0TTIN208	Port	ADCA0TRG2	
	ADCA0TTIN209	TAPA0	TAPA0TADOUT1	
	ADCA0TTIN210	Not connected	—	
	ADCA0TTIN211	Not connected	—	
	ADCA0TTIN212	Not connected	—	
	ADCA0TTIN213	Not connected	—	
	ADCA0TTIN214	Not connected	—	
	ADCA0TTIN215	Not connected	—	

Note For the trigger input signals ADCA0TTINi00 and ADCA0TTINi01, the following signals are connected.

- The logical sum (OR) of INTTAUB0I0 (TAUB0INT0) to INTTAUB0I15 (TAUB0INT15) is used as the trigger input signal ADOPA_iADCATTIN00.

23.2 Functional Overview

The A/D converter A (ADCA_n) converts analog input signals into digital values.

Features summary

The ADCA_n has the following features:

- Support of 10-bit and 12-bit resolution
- A/D conversion based on successive approximation method
- A/D conversions of up to 18 analog input signals
- A/D conversions of up to 3 differently-prioritized groups of channels
- One-shot and continuous A/D conversion modes (channel group 0 only)
- Autorepeat function (channel repeat mode)
- Software and hardware start trigger modes
- Selectable hardware trigger source from multiple input signals
- Configurable channels on which A/D conversion end interrupt is generated at conversion completion
- Three types of conversion result check
- Discharge function to empty the capacitor before a new sample value is stored
- On-off switch function for buffer amplifier
- Self-diagnosis functions to check the ADCA components

The following figure shows the main components of the ADCAn.

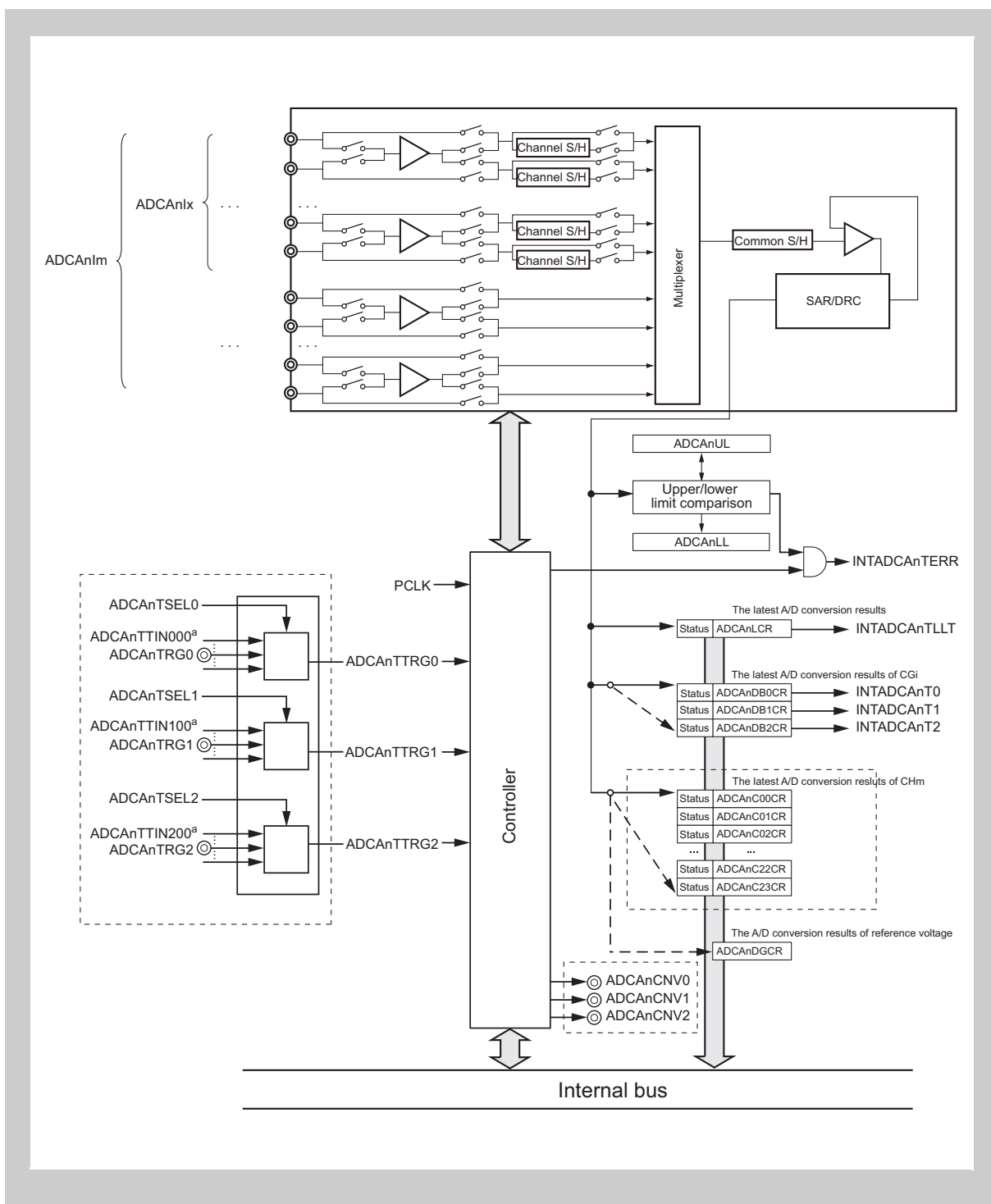

Figure 23-1 ADCAn Block Diagram

Note For detail of connecting unit, see Table 23-2, Units to which Hardware Trigger Signals are Connected.

23.3 Functional Description

The A/D converter A (ADCA_n) converts up to 18 analog input signals into digital values and supports 10-bit and 12-bit resolution.

Note The setting of 10-bit or 12-bit resolution is applied to all the channels. The resolution cannot be set independently for each channel.

Channels and channel groups

Input channels can be grouped into 3 channel groups (CG). A list of input channels assigned to each CG is called the scan list (also applied to the diagnostic A/D conversion of CG0). The scan list can be easily set in 1 register and re-configured during A/D conversion. The A/D conversion of all the channels included in the scan list is called the scan list conversion.

The ADCA_n supports up to 3 differently-prioritized channel groups and 2 conversion modes:

- One-shot conversion mode: When channel repeat mode is not used, the scan list conversion is performed one time. When channel repeat mode is used, each channel of the scan list is performed specified times (1 to 4).
- Continuous conversion mode: The scan list conversion is performed repeatedly.

A/D conversion

The A/D conversion can be triggered by software or hardware.

A multiplexer selects the channel to be converted and the common sample and hold circuit holds the input voltage.

The successive approximation register (SAR) holds the output voltage values of the digital-to-analog converter (DAC) to be compared with the analog input voltage values, as the 10-bit or 12-bit digital values.

After each successful conversion, the INTADCA_nTLLT interrupt is generated.

A/D conversion result registers

When the A/D conversion is complete, the contents of the SAR register are stored in 3 registers, allowing the latest conversion results, the latest conversion results for CG_i, and the latest conversion results for channel *m* to be read, respectively.

Depending on the setting, the ADCA_n generates a conversion end interrupt after the A/D conversion of certain channels and/or at the end of the A/D conversion of all the channels of a channel group.

Conversion result check

The ADCA_n allows the A/D conversion results to be checked using the following functions.

- Overwrite check for A/D conversion result
- Read flag for A/D conversion result
- Upper/lower limit comparison for A/D conversion result

Discharge

If required, the internal capacitor of the sample and hold circuit can be discharged prior to every conversion.

On-off switch function for buffer amplifier In order to reduce the load of the external analog signal source, the signal can be connected to an internal buffer amplifier.
The buffer amplifier accelerates charging of the internal sampling capacitor during A/D sampling.

Self-diagnosis functions The following 4 self-diagnosis functions are provided to verify that the ADCAn works properly and to detect open analog input pins:

- Diagnosis of the A/D conversion circuit
- Diagnosis of the channel multiplexer
- Diagnosis of the analog input pins
- Diagnosis of the channel sample and hold circuit

Available stabilization time The optimal stabilization time can be secured after power on by setting an arbitrary value to the stabilization counter.

23.3.1 Basic Operation

This section describes the basic procedure for an A/D conversion. More detailed descriptions are given in the following sections.

1. To optimize the start-up time after power on of the A/D converter (ADCA0CTL1.ADCA0GPS = 1), adjust the stabilization time by modifying the setting of stabilization counter ADCAnCNT before the A/D converter is powered on. Refer to 23.3.15, Stabilization Control.
2. Before you enable the A/D converter (ADCAnCTL0.ADCAnCE = 1), set power on, resolution, ADCAn clock, trigger mode, conversion mode, interrupt generation, channel groups, channel S/H function sampling time, channel S/H hold wait time, buffer amplifier time, discharge time and so on in the following registers:
 - ADCAnCTL0 register
 - ADCAnCTL1 register
 - ADCAnIOCi register
 - ADCAnCGi register
 - ADCAnTSELi register
 - ADCAnSHCTL register
 - ADCAnSMCNT register
 - ADCAnSHHCNT register
 - ADCAnAMPCNT register
 - ADCAnDISCNT register
3. If you want to check that the A/D conversion results are within a specified range, enable the upper/lower limit comparison function for conversion results of the desired channels (ADCAnCTL2.ADCAnRCKm) and specify the lower and upper limits in ADCAnLL and ADCAnUL.
4. If you want the capacitor of the sample and hold circuit to be discharged before sampling a new value, enable the discharge function by setting ADCAnCTL1.ADCAnDISC to 1.
5. Enable or disable the buffer amplifier by setting ADCAnCTL1.ADCAnBPC. If you use the channel S/H function, enable the buffer amplifier function.
6. Enable the A/D converter by setting ADCAnCTL0.ADCAnCE to 1.
If you set the stabilization counter ADCAnCNT register, the A/D converter starts A/D conversion after the stabilization time (refer to Section 27.6.15, A/D Converter Characteristics) is elapsed after power on. If you don't use the stabilization counter ADCAnCNT register, enable the A/D converter after more than power down recovery time is elapsed after power on of A/D converter (ADCA0CTL1.ADCA0GPS=1).
7. Depending on the trigger mode configured, A/D conversion is started by either of the following channel group-related start triggers.
 - Software trigger (ADCAnTRGi.ADCAnSTTi = 1)
 - Hardware trigger (input signal ADCAnTTRGi)
 If the A/D conversions of multiple CGs are triggered, the order of A/D conversions depends on the priority of the CGs.
8. The A/D conversion end interrupt INTADCAnTi is generated when the A/D conversion of channels set in ADCAnIOCi is completed.
9. Read the results from the A/D conversion result registers ADCAnLCR, ADCAnDBiCR, and ADCAnCmCR.

10. Monitor the following registers:
 - ADCAnSTR1: Check whether A/D conversion results have been overwritten before reading them out according to their use.
 - ADCAnSTR0: Check whether A/D conversion results are within the specified value range (only if the upper/lower limit comparison function for A/D conversion results has been enabled).
11. Before you reconfigure the A/D converter, disable it by clearing ADCAnCTL0.ADCAnCE to 0.

Note The self-diagnosis functions are described in Section 23.3.11, Self-Diagnosis Functions.

23.3.2 Clock Usage

The ADCAn clock ADCAnTCLK is derived from PCLK. The division ratio is specified in ADCAnCTL1.ADCAnFR[1:0].

Caution The maximum and minimum frequencies of ADCAnTCLK should be 48 MHz and 24 MHz, respectively.
For frequency setting, see Table 23-3, Total Conversion Times (10- and 12-bit Resolution).

23.3.3 Channel and Channel Group

Input channels are grouped into channel groups (CG). The scan list for each CG can be set in a register and reconfigured during A/D conversion. The conversion settings for a CG are applied to all the channels of the CG.

The ADCAn supports up to 3 channel groups CGi (i = 0 to 2). The channels of CGi are specified in ADCAnCGi.

Note The ADCAn processes A/D conversion requests for CGs only. To convert a single channel, only 1 channel must be assigned to a CG.

(1) Order of A/D Conversion

If a trigger for a CG occurs, the channels of the CG are converted one by one in ascending order (from CH01 to CH18).

If A/D conversion requests for multiple CGs are pending, the CGs are converted in the following hierarchical order:

CG2 (highest priority) > CG1 > CG0 (lowest priority)

The current A/D conversion is interrupted when a start trigger for a higher-priority CG is set. Depending on the setting in ADCAnCTL1.ADCAnTRMi, there are 2 options:

- The A/D conversion of CG is interrupted immediately (ADCAnCTL1.ADCAnTRMi = 0).

After the A/D conversions of all the higher-priority CGs are finished, the A/D conversion of the interrupted channel is resumed.

- The A/D conversion of the current channel is completed before the higher-priority CG is converted (ADCAnCTL1.ADCAnTRMi = 1).

After the A/D conversions of all the higher-priority CGs are finished, the interrupted A/D conversion is resumed from the next channel.

ADCAnSTR2.ADCAnST[2:0] indicates the current conversion status of all the CGs.

Examples The following figures illustrate the different types of A/D conversion interruption;
CH3, CH9, and CH20 are assigned to CG0, CH5 and CH9 are assigned to CG2.

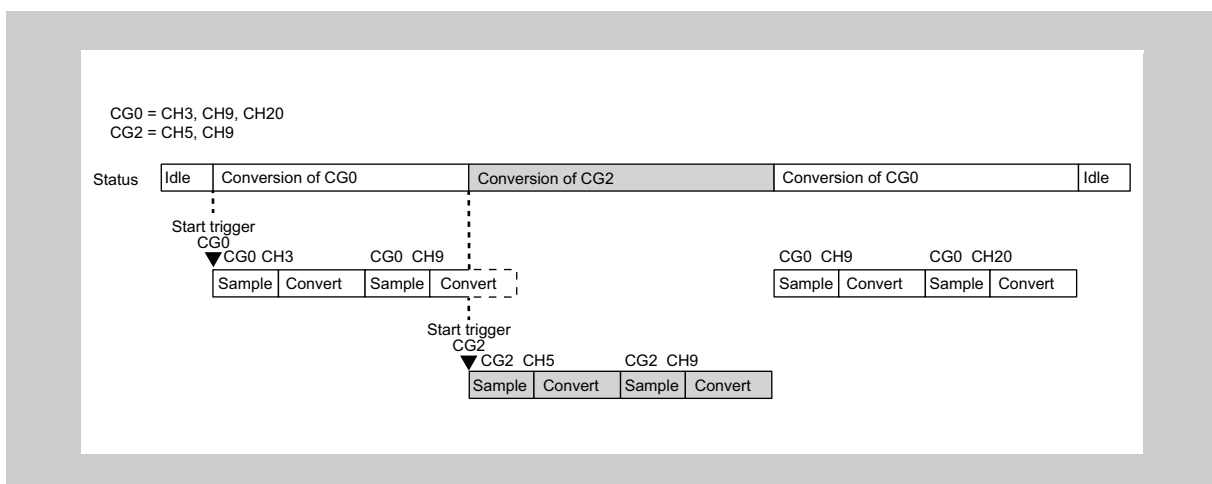

Figure 23-2 When A/D Conversion of CG0 is Immediately Interrupted (ADCAnCTL1.ADCAnTRM0 = 0)

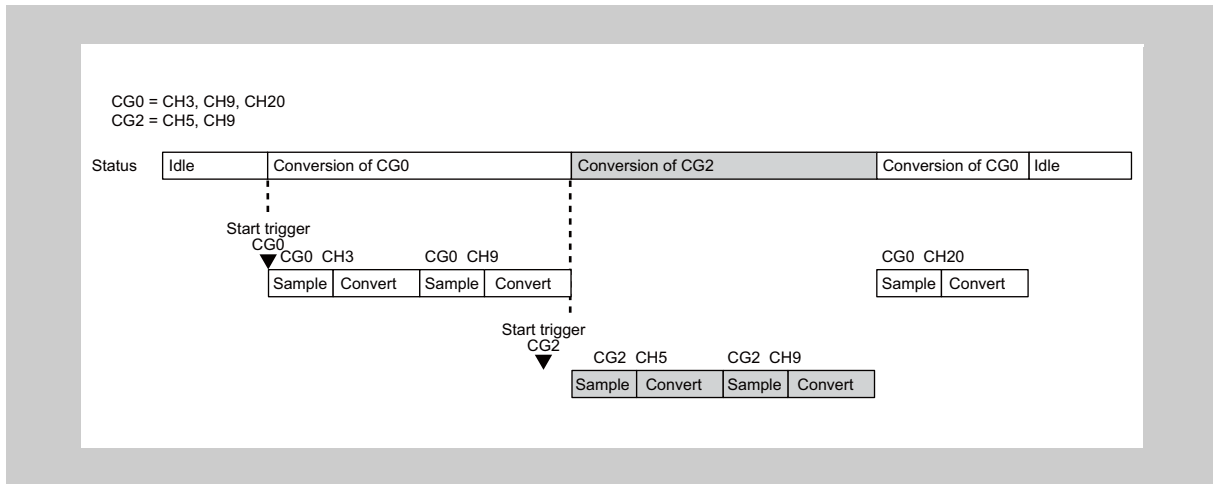

Figure 23-3 When Waiting until A/D Conversion of Current Channel is Completed (ADCACTL1.ADCANTRM0 = 1)

23.3.4 A/D Conversion Modes

The A/D converter provides 2 conversion modes:

Mode	Operation	Channel Group
One-shot conversion mode	<p>One-shot conversion mode can specify following modes.</p> <ul style="list-style-type: none"> When channel repeat mode is not used (ADCACTL0.ADCAnSTM=0), the scan list conversion is performed one time. When channel repeat mode is used (ADCACTL0.ADCAnSTM=1), each channel of the scan list is performed specified times. <p>Example: CGi=CH1, CH2, CH3, and specified repeat three times. The repeat order is CH1 → CH1 → CH1 → CH2 → CH2 → CH2 → CH3 → CH3 → CH3</p>	CG0, CG1, CG2
Continuous conversion mode	The scan list conversion is performed repeatedly.	CG0

Note 1. When a running A/D conversion is interrupted by an A/D conversion request for a higher priority CG, the interrupted conversion is automatically continued when all the conversions of higher priority CGs are finished (see Section 23.3.3 (1) Order of A/D Conversion).

Note 2. CG1 and CG2 are processed in one-shot conversion mode regardless of the conversion mode settings. For CG0, the A/D conversion mode can be set in ADCAnCTL1.ADCAnMD0.

(1) One-shot Conversion Mode

When channel repeat mode is not used (ADCACTL0.ADCAnSTM=0), the CGi scan list conversion is performed one time by a start trigger.

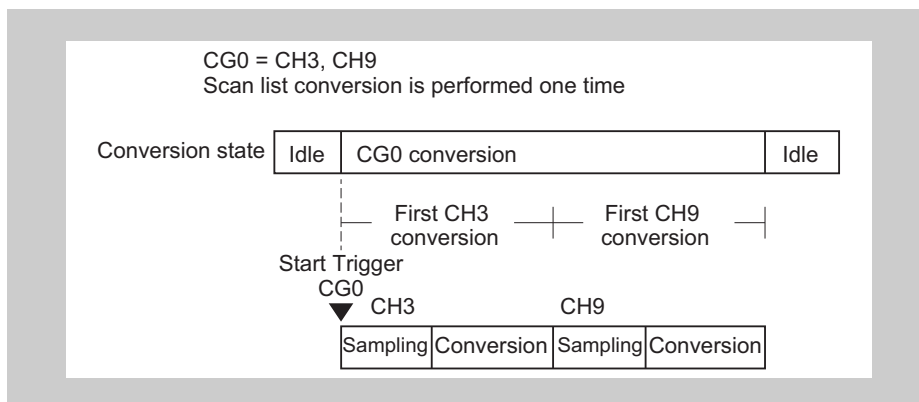

Figure 23-4 When channel repeat mode is not used

When channel repeat mode is used (ADCACTL0.ADCAnSTM=1), each channel of the scan list is performed specified times by ADCACTL0.ADCAnSCTi[1:0].

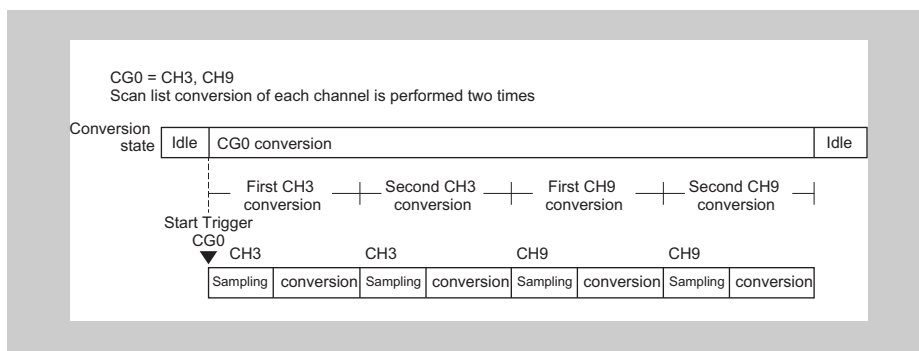

Figure 23-5 When channel repeat mode is used (repeat two times)

Operation When Start Trigger is Input Before Completion of Conversion

A/D converter can hold a start trigger before completion of conversion. Therefore, if more than one following start triggers (ignored after second input) are input before completion of CGi A/D conversion, A/D conversion is performed continuously.

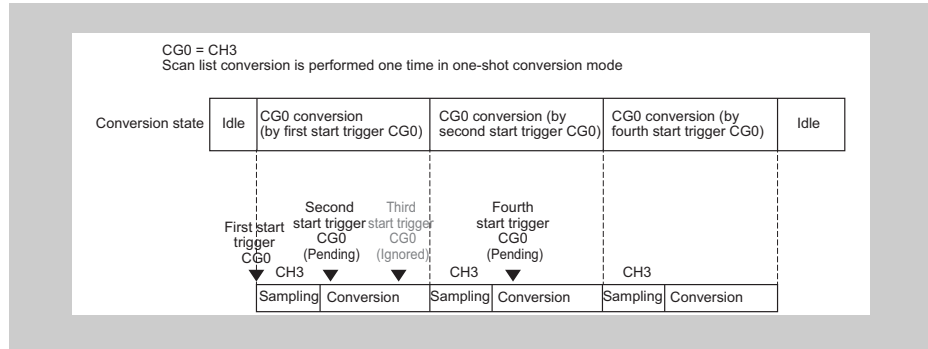

Figure 23-6 Operation When Start Trigger is Input Before Completion of Conversion

Caution Low priority start triggers before completion of conversion are ignored during performing of a high priority CG conversion. Low priority start trigger before completion of conversion is held before start of high priority CG conversion. If any start trigger is not input, low priority start trigger is accepted during performing of a high priority CG conversion.

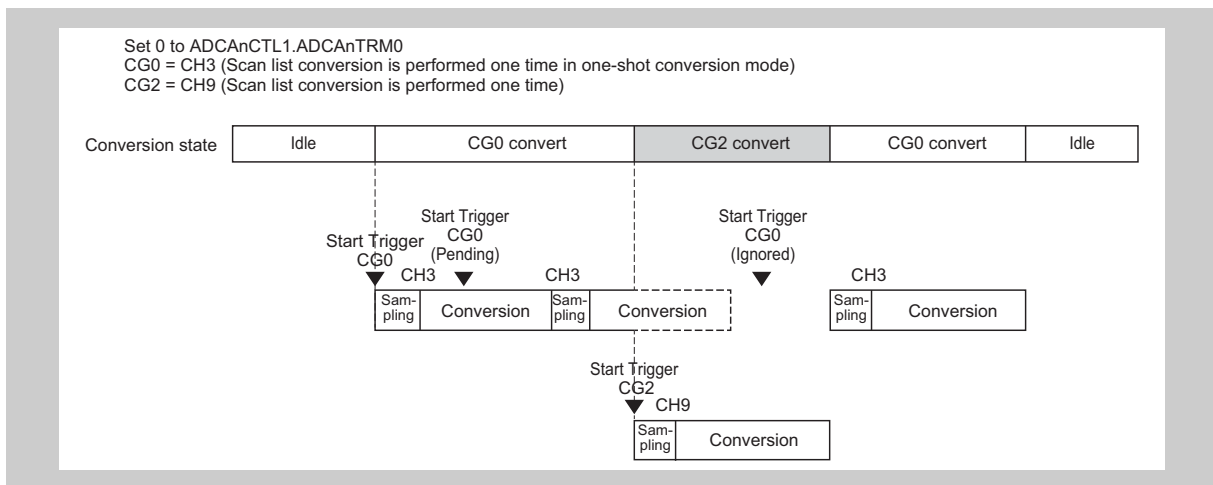

Figure 23-7 Operation When Start Trigger is Input Before Completion of Conversion (Input High Priority Start Trigger)

(2) Continuous Conversion Mode

Continuous conversion mode is available for CG0 only (ADCA_nCTL1.ADCA_nMD0 = 1).

In continuous conversion mode, a start trigger causes the channels of CG0 to be sampled and converted continuously until a stop trigger is generated or another stop condition occurs (see Section 23.3.6, Stopping A/D Conversion (Stop Trigger)).

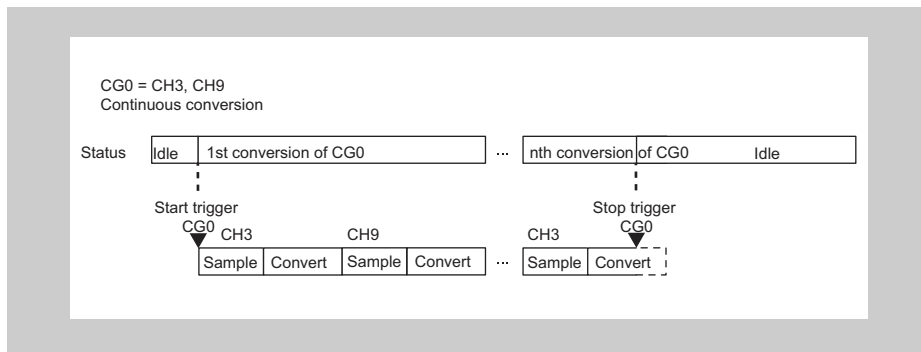

Figure 23-8 Continuous Conversion Mode

Caution The idle state is entered after a stop trigger is generated and the sampling and conversion are not performed.

Note Additional start triggers for CG0 are ignored in continuous conversion mode.

23.3.5 Starting A/D Conversion (Start Triggers)

A/D conversion can be started by a software or hardware trigger which is specified in `ADCAnCTL1.ADCAnMD1`.

When an A/D conversion is triggered for multiple CGs, the conversion order depends on the priorities of the CGs (see Section 23.3.3 (1), Order of A/D Conversion).

Note 1. The ADC_n ignores triggers for CG_i if there is no channel assigned to the CG_i (`ADCAnCGi = 0000 0000H`).

Note 2. In one-shot conversion mode, the A/D converter stores one start trigger.

If start triggers are set for CG_i before the previously triggered A/D conversion of the CG_i is completed, the first additional start trigger causes another A/D conversion to be performed immediately after the current CG_i A/D conversion, but all the other additional start triggers of the same CG_i are ignored (see Figure 23-6, Operation When Start Trigger is Input Before Completion of Conversion).

Note 3. In continuous conversion mode, additional start triggers that are generated before a stop trigger is generated are ignored.

(1) Software Start Trigger

The A/D conversion of CG_i is triggered by setting `ADCAnTRGi.ADCAnSTTi` to 1, if the A/D converter is enabled (`ADCAnCTL0.ADCAnCE = 1`).

Example of software start trigger timing

The following figure shows the timing of a software start trigger under the following conditions:

- `ADCAnTCLK` clock = `PCLK/2` (`ADCAnCTL1.ADCAnFR[1:0] = 01B`)

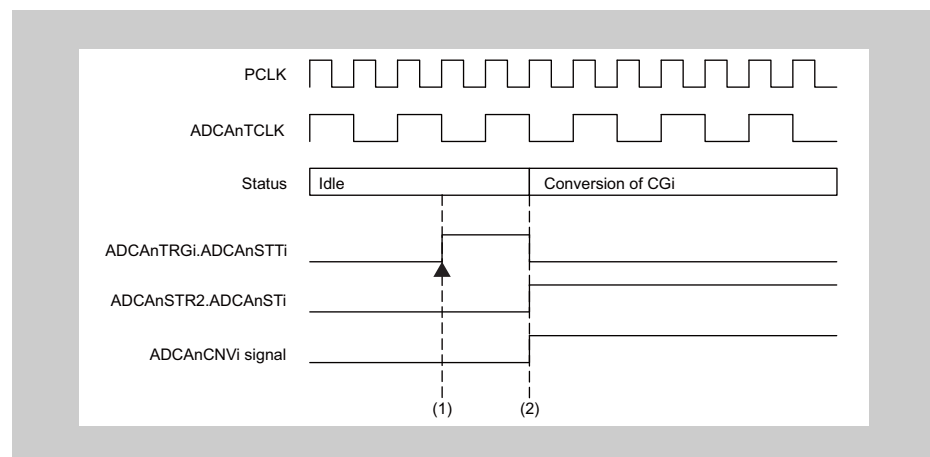

Figure 23-9 Example of Software Start Trigger Timing

1. Software trigger for CG_i is written.
2. A/D conversion starts at the next falling edge of `ADCAnTCLK`.

The status signal `ADCAnCNVi` becomes active and the status bit `ADCAnSTR2.ADCAnSTI` is set to indicate that A/D conversion of CG_i is running.

(2) Hardware Start Trigger

The A/D conversion of CG_i is triggered by valid edge detection of signal ADCAnTTRG_i, if the A/D converter is enabled (ADCAnCTL0.ADCAnCE = 1) and the hardware trigger mode is set (ADCAnCTL1.ADCAnMD1 = 1).

The valid edge is specified in ADCAnCTL1.ADCAnTiETS[1:0] for each CG.

Hardware trigger expansion This product supports a hardware trigger expansion. Multiple hardware trigger sources can be specified for each ADCAnTTRG_i input: 6 for CG0 and 8 each for CG1 and CG2. ADCAnTSEL_i specifies the input signals to be used as ADCATTRG_i.

Note For units to which the hardware trigger signals are connected, see Table 23-2, Units to which Hardware Trigger Signals are Connected.

Hardware start trigger timing The A/D converter starts A/D conversion when a valid edge of ADCAnTTRG_i is detected.

The following figure shows the timing of a hardware start trigger under the following conditions:

- ADCAnTCLK clock = PCLK/2 (ADCAnCTL1.ADCAnFR[1:0] = 01_B)
- Valid edge of ADCAnTTRG_i is rising edge (ADCAnCTL1.ADCAnTiETS[1:0] = 01_B)

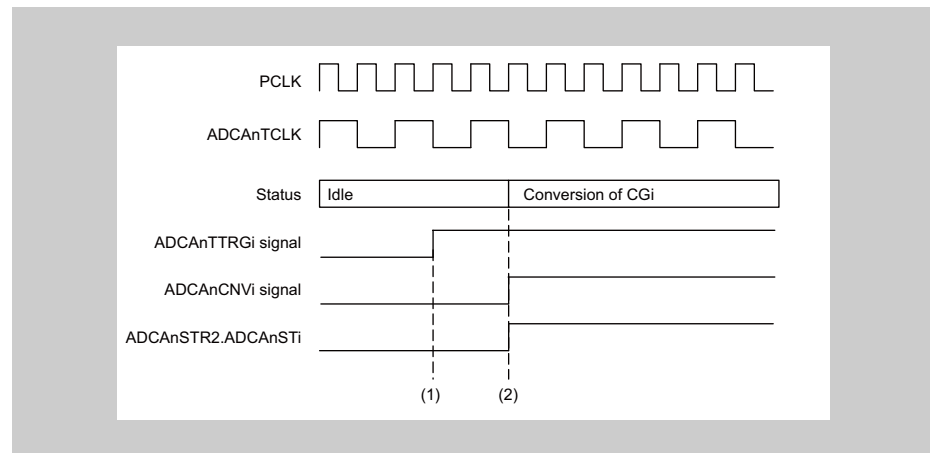

Figure 23-10 Hardware Start Trigger Timing

1. Input signal ADCAnTTRG_i rises.
2. A/D conversion starts at the next falling edge of ADCAnTCLK.

The status signal ADCAnCNV_i becomes active and the status bit ADCAnSTR2.ADCAnST_i is set to indicate that A/D conversion of CG_i is running.

23.3.6 Stopping A/D Conversion (Stop Trigger)

- The A/D converter is powered off (ADCA_nCTL1.ADCAnGPS = 0)
- The A/D converter is disabled (ADCA_nCTL0.ADCAnCE = 0)

Caution When a hardware trigger is used, set the ADCA_nCTL1.ADCAnTiETS[1:0] bits to 00_B (the valid edge of the hardware conversion trigger is not detected) before disabling the A/D converter, so that the start trigger is not generated.

23.3.7 Resolution, Sampling Time and Conversion Time

The overall conversion time is the total of the discharge time (when the discharge function is enabled), sampling time, and A/D conversion time.

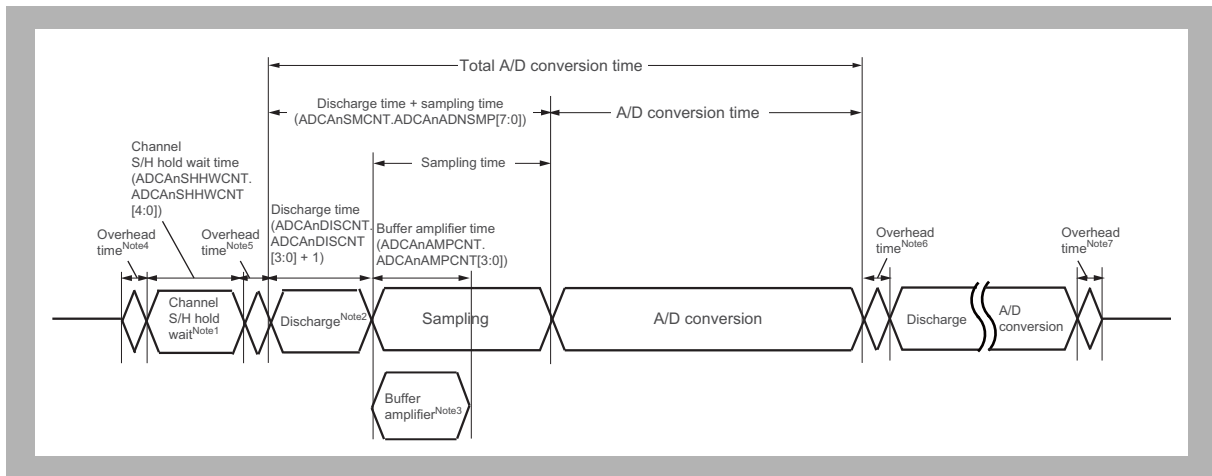

Figure 23-11 Total Conversion Time

- Note 1. This time is required when the channel S/H function is enabled.
- Note 2. This time is required when the discharge function is enabled.
- Note 3. This time is required when the buffer amplifier function is enabled and the channel S/H function is disabled.
- Note 4. Overhead time for acceptance of A/D conversion requests: 1 clock cycle (ADCA nTCLK)
- Note 5. Overhead time for initialization of A/D conversion: 1 clock cycle (ADCA nTCLK)
- Note 6. Overhead time for storing the results of A/D conversion, accepting A/D conversion requests, and initialization for A/D conversion (see the overhead times in Table 23-3, Total Conversion Times (10- and 12-bit Resolution)).
- Note 7. Overhead time for storing the results of A/D conversion: 3 clock cycles (ADCA nTCLK) when ADCA nTCLK = PCLK; 2 clock cycles (ADCA nTCLK) when ADCA nTCLK = PCLK/2
- The sampling time is the time taken to connect the analog input voltage to the sample & hold circuit.
 - The buffer amplifier time is the time over which the buffer amplifier is operating. Sampling for A/D conversion proceeds even while the buffer amplifier is operating.
 - The A/D conversion time is the time required to obtain one digital value from an analog input voltage.
 - The channel S/H hold wait time is the time after the analog input is sampled until the value held is output to the common S/H circuit.
 - Set the following registers according to the sampling time and total conversion time to set the A/D clock, channel S/H hold wait time, discharge time, buffer amplifier time and sampling time. The settings are shown in Table 23-3, Total Conversion Times (10- and 12-bit Resolution).
 - ADCA nCTL1.ADCA nFR [1:0]
 - ADCA nSHHCNT.ADCA nSHHCNT [4:0] (when channel S/H is ON)
 - ADCA nDISCNT.ADCA nDISCNT [3:0] (when discharge is ON)
 - ADCA nAMP CNT.ADCA nAMP CNT [3:0] (when the buffer amplifier is ON)
 - ADCA nSMCNT.ADCA nADNSMP [7:0]

Caution Do not set values other than those listed in Table 23-3, Total Conversion Times (10- and 12-bit Resolution) in the above registers.

Table 23-3 Total Conversion Times (10- and 12-bit Resolution)

When discharge is ON

PCLK [MHz]	ADCA _n TCLK [MHz]	Total conversion time [us]	Discharge time [us] ¹	Sampling time [us]	A/D conversion time [us]	Overhead time [us]	Settings				
							ADCA _n CTL1. ADCA _n FR [1:0]	ADCA _n SHHCNT. ADCA _n SHHCNT [4:0] ²	ADCA _n DISCNT.A DCA _n DISCNT [3:0]	ADCA _n AMPCNT. ADCA _n AMPCNT [3:0] ³	ADCA _n SMCNT. ADCA _n ADNSMP [7:0]
80	PCLK/2	1.600	0.325	0.525	0.750	0.100	01 _H	8 _H	C _H	A _H	22 _H
64	PCLK/2	1.813	0.344	0.531	0.938	0.125	01 _H	7 _H	A _H	8 _H	1C _H
48	PCLK	1.458	0.333	0.500	0.625	0.104	00 _H	A _H	F _H	C _H	28 _H
40	PCLK	1.575	0.325	0.500	0.750	0.125	00 _H	8 _H	C _H	A _H	21 _H
32	PCLK	1.781	0.344	0.500	0.938	0.156	00 _H	7 _H	A _H	8 _H	1B _H
24	PCLK	2.125	0.375	0.500	1.250	0.208	00 _H	5 _H	8 _H	6 _H	15 _H

Note 1. The discharge time in the table indicates the time discharge takes (the actual discharge time (ADCA_nDISCNT.ADCA_nDISCNT[3:0]) + 1).

Note 2. Be sure to make this setting if the channel S/H function is to be enabled.

Note 3. Be sure to make this setting if the buffer amplifier is to be enabled.

When discharge is OFF

PCLK [MHz]	ADCA _n TCLK [MHz]	Total conversion time [us]	Sampling time [us]	A/D conversion time [us]	Overhead time [us]	Settings			
						ADCA _n CTL1. ADCA _n FR [1:0]	ADCA _n SHHCNT. ADCA _n SHHCNT [4:0] ¹	ADCA _n AMPCNT. ADCA _n AMPCNT [3:0] ²	ADCA _n SMCNT. ADCA _n ADNSMP [7:0]
80	PCLK/2	1.275	0.525	0.750	0.100	01 _H	8 _H	A _H	15 _H
64	PCLK/2	1.469	0.531	0.938	0.125	01 _H	7 _H	8 _H	11 _H
48	PCLK	1.125	0.500	0.625	0.104	00 _H	A _H	C _H	18 _H
40	PCLK	1.250	0.500	0.750	0.125	00 _H	8 _H	A _H	14 _H
32	PCLK	1.438	0.500	0.938	0.156	00 _H	7 _H	8 _H	10 _H
24	PCLK	1.792	0.542	1.250	0.208	00 _H	5 _H	6 _H	0D _H

Note 1. Be sure to make this setting if the channel S/H function is to be enabled.

Note 2. Be sure to make this setting if the buffer amplifier is to be enabled.

23.3.8 Interrupt Generation

(1) A/D Conversion End Interrupt: INTADCA_nT_i

The interrupt INTADCA_nT_i indicates that the new A/D conversion result has been stored in the A/D conversion result register.

The A/D conversion end interrupt is generated at the A/D conversion completion of any channel of CG_i which is specified in ADCA_nIOCI.

If no channel is specified (ADCA_nIOCI = 0000 0000_H), the interrupt INTADCA_nT_i is generated at the end of the A/D conversion of CG_i.

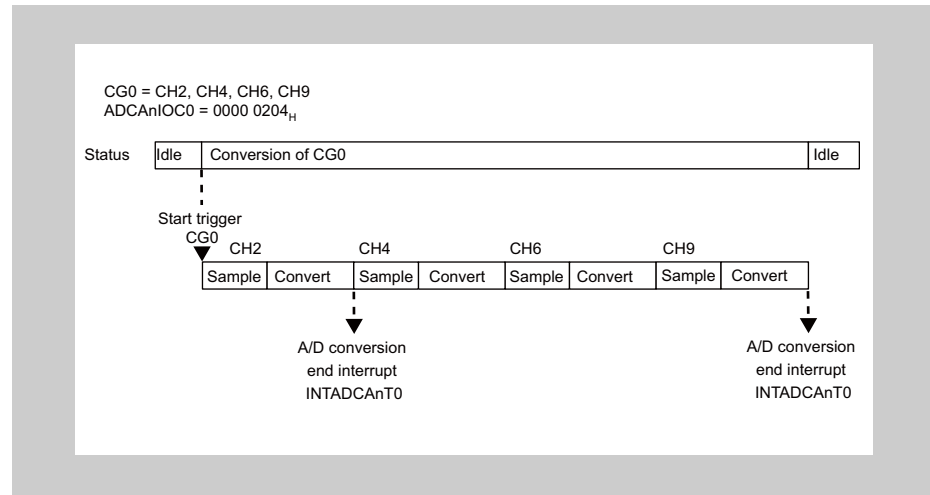

Figure 23-12 Generation of A/D Conversion End Interrupt INTADCA_nT_i

- Note 1. ADCA_nIOCI can be written at any time even when the A/D converter is enabled (ADCA_nCTL0.ADCA_nCE = 1). The new value takes effect after the current A/D conversion of CG_i has been completed.
- Note 2. ADCA_nIOCI is associated with ADCA_nCG_i and their buffer registers must be updated simultaneously. As the update time depends on writing to ADCA_nCG_i, always write to ADCA_nIOCI before ADCA_nCG_i if you want to change the interrupt generation for a CG.

(2) Error Interrupt INTADCA_nTERR

The error interrupt INTADCA_nTERR is generated in the following cases:

- If the A/D conversion result of a specified channel is outside the specified range with the upper/lower limit comparison for A/D conversion results enabled, refer to Section 23.3.10 (3), Upper/Lower Limit Comparison for A/D Conversion Results.
- If the A/D conversion result in ADCA_nLCR, ADCA_nDBiCR, or ADCA_nCmCR has been overwritten before it was read

The generation of the error interrupt INTADCA_nTERR when an A/D conversion result is overwritten can be controlled separately for each register by the setting of bits ADCA_nCTL0.ADCA_nOEM[4:0]. For details, refer to Section 23.3.10(1), Overwrite Check for A/D Conversion Results.

23.3.9 Storage of A/D Conversion Results

(1) A/D Conversion Result Registers

The A/D conversion results are stored in the following registers:

- ADCAnLCR register
This register stores the latest A/D conversion result.
- ADCAnDBiCR register
This register stores the latest A/D conversion result of CGi.
- ADCAnCmCR register
This register stores the latest A/D conversion result of channel m.

These registers contain the digital values for the sampled analog input voltages in bits 15 to 00. They also provide additional information, for example, status flags allowing to check the A/D conversion result (see Section 23.3.10, Result Check Functions).

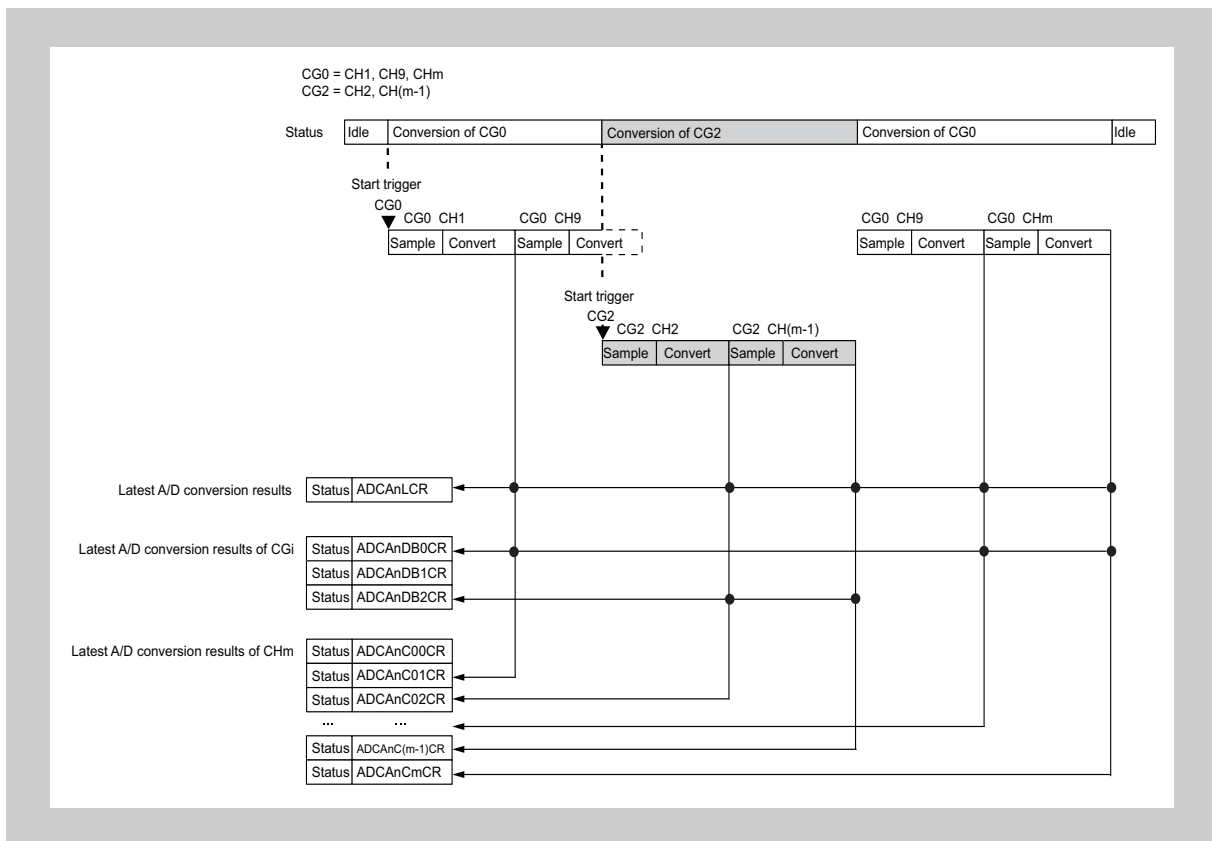

Figure 23-13 Storage of AD Conversion Results

(2) Setting about Storage of Conversion Result**(a) Alignment Specification of Conversion Result**

The ADCAnCTL1.ADCAnCRAC bit can specify whether the 12-bit or 10-bit A/D conversion result is right-aligned (ADCAnCRAC = 0) or left-aligned (ADCAnCRAC = 1).

(b) Reading and Clearing Conversion Result

The ADCAnCTL1.ADCAnRCL bit can specify whether the A/D conversion result ADCAnCmCR is retained or cleared after being read out.

(3) Relationship between Analog Input Voltage and A/D Conversion Result

There is a relationship between the analog input voltages that are input to the analog input pin (ADCAnIm) and the A/D conversion result values (values of the ADCAnLCR[15:00] bits, ADCAnCmCR[15:00] bits and ADCAnDBiCR[15:00] bits), as shown in the following equations.

$$\text{A/D conversion result value} = \text{INT} \left(\frac{V_{IAN} - AV_{REFnM}}{AV_{REFnP} - AV_{REFnM}} \times 2^k + 0.5 \right)$$

or

$$(\text{A/D conversion result value} - 0.5) \times \frac{AV_{REFnP} - AV_{REFnM}}{2^k} \leq V_{IAN} - AV_{REFnM} < (\text{A/D conversion result value} + 0.5) \times \frac{AV_{REFnP} - AV_{REFnM}}{2^k}$$

INT():	A function which returns the integer part of the value in parentheses
V_{IAN} :	Analog input voltage
AV_{REFnP} :	AV_{REFnP} pin voltage
AV_{REFnM} :	AV_{REFnM} pin voltage
A/D conversion results:	Values of the ADCAnLCR[15:00] bits, ADCAnCmCR[15:00] bits and ADCAnDBiCR[15:00] bits
k:	Resolution

Figure 23-14 shows the relationship between the analog input voltages and the A/D conversion result values.

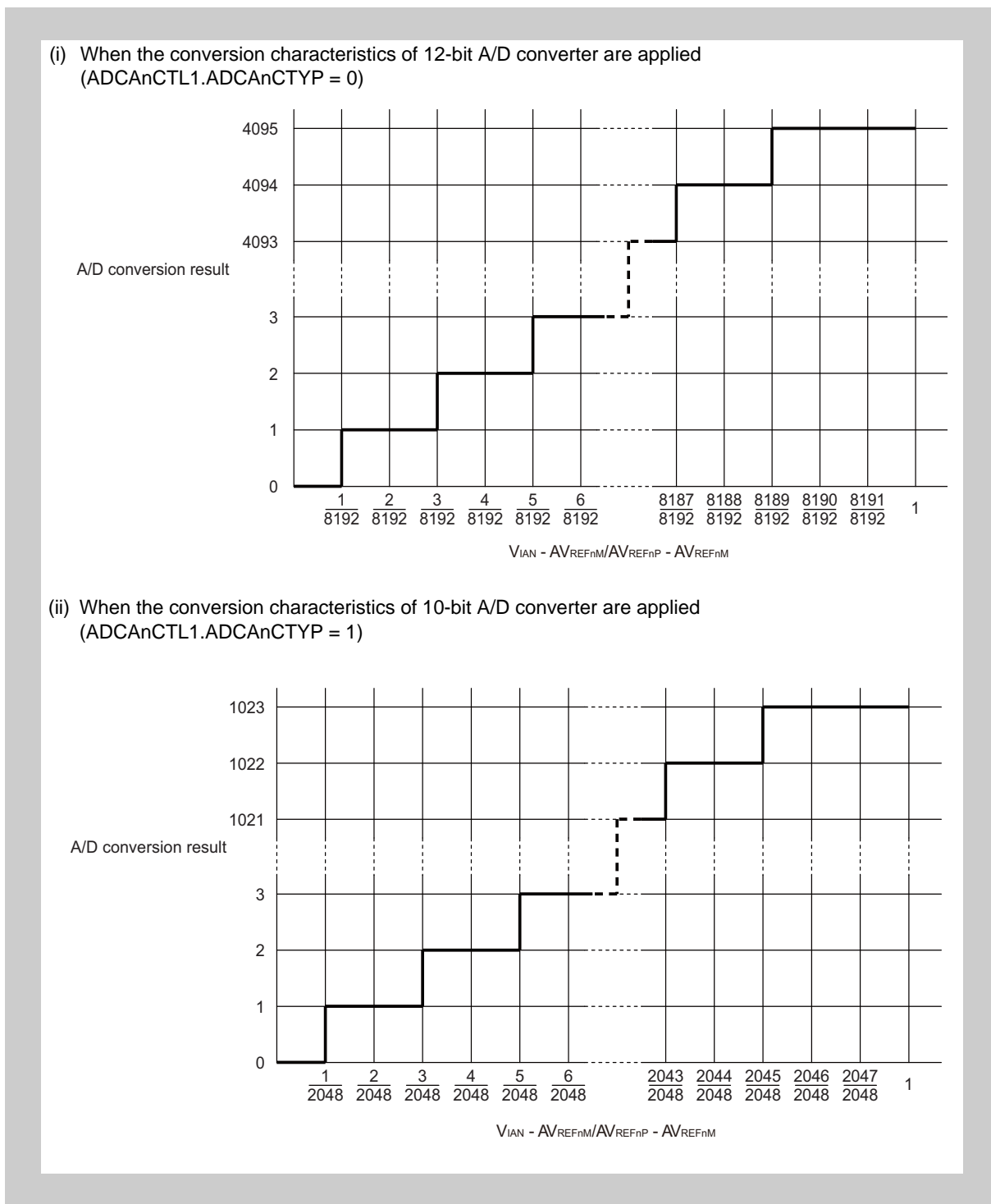

Figure 23-14 Relationship between Analog Input Voltages and A/D Conversion Results

23.3.10 Result Check Functions

The ADCAn provides the following functions to check the A/D conversion results:

- Overwrite check for A/D conversion results
- Read flag for A/D conversion results
- Upper/lower limit comparison for A/D conversion results

(1) Overwrite Check for A/D Conversion Results

The ADCAn can check if an A/D conversion result has been overwritten before it is read.

Error flags Each of the A/D conversion result registers provides the overwrite error flag as follows:

ADCA_nLCR.ADCAnLER1
 ADCAnDBiCR.ADCAnDBiER1
 ADCAnCmCR.ADCAnCmER1

For example, if the A/D conversion result stored in ADCAnCmCR has been overwritten before it is read, ADCAnCmCR.ADCAnCmER1 is set to 1.

The same applies to ADCAnLCR and ADCAnDBiCR.

The value of ADCAnCmCR.ADCAnCmER1 is also reflected in ADCAnSTR1.ADCAnOWEm.

Error interrupt The error interrupt INTADCAnTERR is generated if an A/D conversion result in ADCAnLCR, ADCAnDBiCR, or ADCAnCmCR is overwritten before it is read.

For the conversion result register that the stored conversion result is not read out, an error interrupt should be masked by appropriately setting ADCAnCTL0.ADCAnOEM[4:0]. (Do not perform the overwrite check for A/D conversion result.)

Unless an error interrupt is masked, the ADCAn does not detect reading of the conversion result. In this case, the ADCAn detects that the result is overwritten at storage of the next A/D conversion result, and the error interrupt INTADCAnTERR occurs.

(2) Read Flag for A/D Conversion Results

The ADCAn can check whether an A/D conversion result has already been read, or not yet been read.

Update status flag Each of the A/D conversion result registers provides the update status flag as follows.

ADCA_nLCR.ADCAnLUR
 ADCAnDBiCR.ADCAnDBiUR
 ADCAnCmCR.ADCAnCmUR

If these flags are set to 1, the updated A/D conversion result has not been read yet. The update status flag is cleared to 0 after the A/D conversion result is read.

(3) Upper/Lower Limit Comparison for A/D Conversion Results

The ADCAn can check if A/D conversion results lie within a configurable value range.

This function can be enabled or disabled for each channel in ADCAnCTL2.

For the enabled channel, the A/D conversion result is compared with the specified lower limit (in ADCAnLL) and upper limit (in ADCAnUL).

Error flag If the A/D conversion result of a specified channel is below the lower limit or above the upper limit, the corresponding error flag ADCAnSTR0.ADCAnRCE is set to 1.

ADCAnSTR0 indicates the error status of upper/lower limit comparison for the latest A/D conversion result for every channel. This register can be used to check which A/D conversion results are outside the specified range.

The value of the result check error flag ADCAnSTR0.ADCAnRCE is also reflected in ADCAnLCR.ADCAnLER0, ADCAnDBiCR.ADCAnDBiER0 and ADCAnCmCR.ADCAnCmER0.

Error interrupt The error interrupt INTADCAnTERR is generated if an A/D conversion result of a specified channel is outside the specified range.

23.3.11 Self-Diagnosis Functions

The following self-diagnosis functions can be used to verify that the ADCAn works properly:

1. Diagnosis of A/D conversion circuit
2. Diagnosis of channel multiplexer
3. Diagnosis of analog input pins
4. Diagnosis of channel sample and hold circuit

The figure below outlines the self-diagnosis functions, which are explained in detail in the following sections.

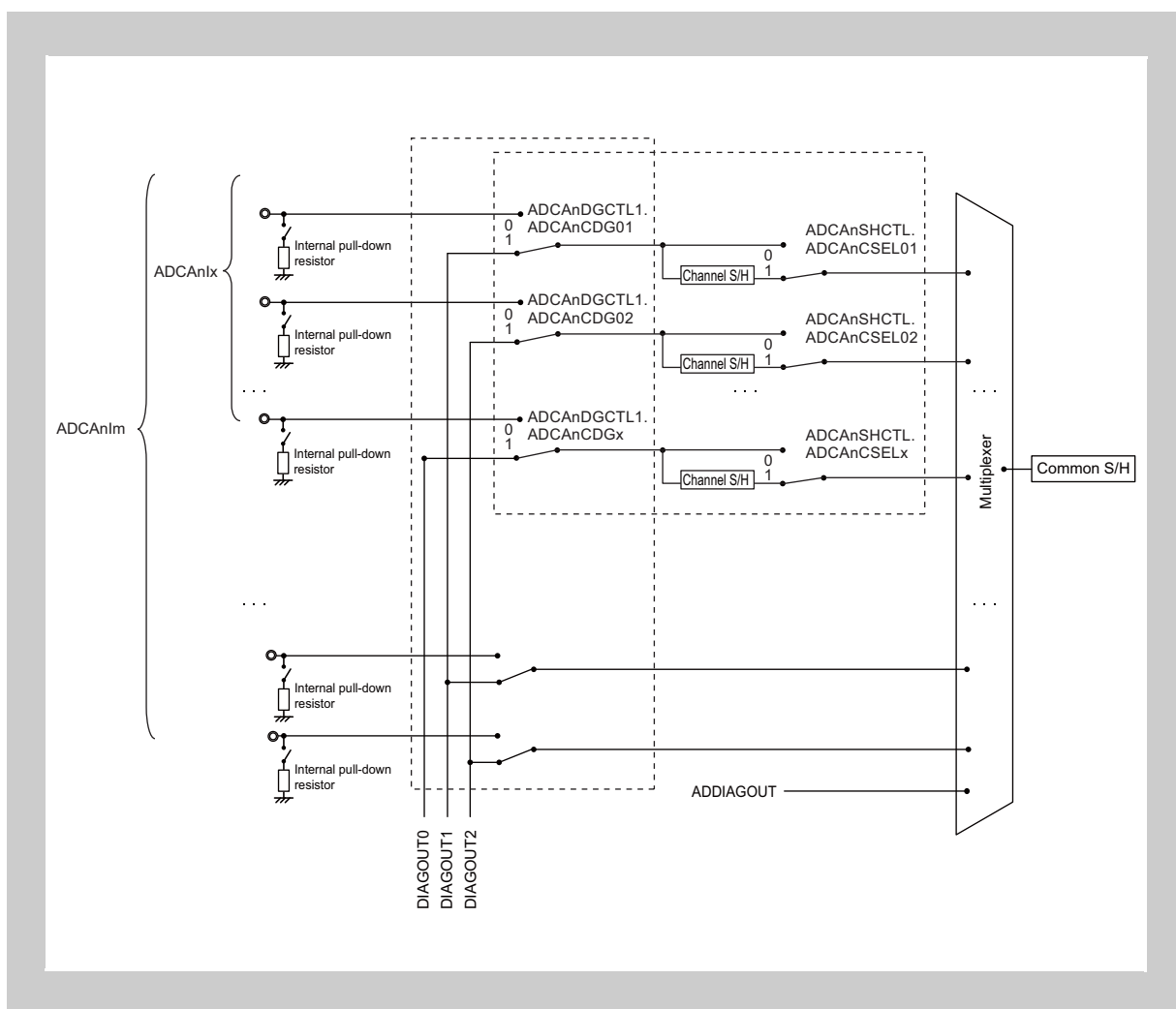

Figure 23-15 Outline of Self-Diagnosis Functions

The following table shows the register settings with which each diagnosis function is available.

Table 23-4 Self-Diagnosis Function Settings

Self-Diagnosis Function	ADCA _n CE Bit = 0	ADCA _n CE Bit = 1
Diagnosis of A/D conversion circuit	Available	Available
Diagnosis of channel multiplexer	Available	Unavailable
Diagnosis of analog input pins	Available	Unavailable
Diagnosis of channel sample and hold circuit	Available	Available

(1) Diagnosis of A/D Conversion Circuit

The ADCAn can diagnose operation of the A/D conversion circuit.

The A/D conversion circuit can be diagnosed during normal A/D conversion operation. The ADCAn additionally converts the reference voltage ADDIAGOUT after the A/D conversion of CG0. If the result of this diagnostic A/D conversion differs greatly from the expected value, the hardware may have had an error or malfunction.

The diagnostic A/D conversion is enabled by setting ADCAnCG0.ADCAnDIAG to 1.

Note The diagnosis of A/D conversion circuit is available for CG0 only.

The diagnostic A/D conversion is started after the A/D conversion of the last channel of CG0 is completed.

- The A/D conversion results of CG0 are stored in the normal A/D conversion result register (see Section 23.3.9 (1), A/D Conversion Result Registers).
- The diagnostic A/D conversion result is stored in ADCAnDGCR.

Bits ADCAnDGCTL0.ADCAnPSEL[2:0] are writable even during A/D conversion in diagnosis of A/D Conversion circuit. However, it must be done at A/D conversion stop state for usual setting change as the procedure below.

1. If conversion is under processing (ADCAnCTL0.ADCAnCE bit = 1), stop it (ADCAnCTL0.ADCAnCE bit = 0).
2. Set ADCAnCG0.ADCAnDIAG bit to 0.
3. Set ADCAnDGCTL0.ADCAnPSEL[2:0] bits to 011_B.
4. Set ADCAnDGCTL0.ADCAnPSEL[2:0] bits to diagnosis voltage.
5. Set ADCAnCG0.ADCAnDIAG bit to 1.

Operation when writing is performed during A/D conversion is shown in the figure below.

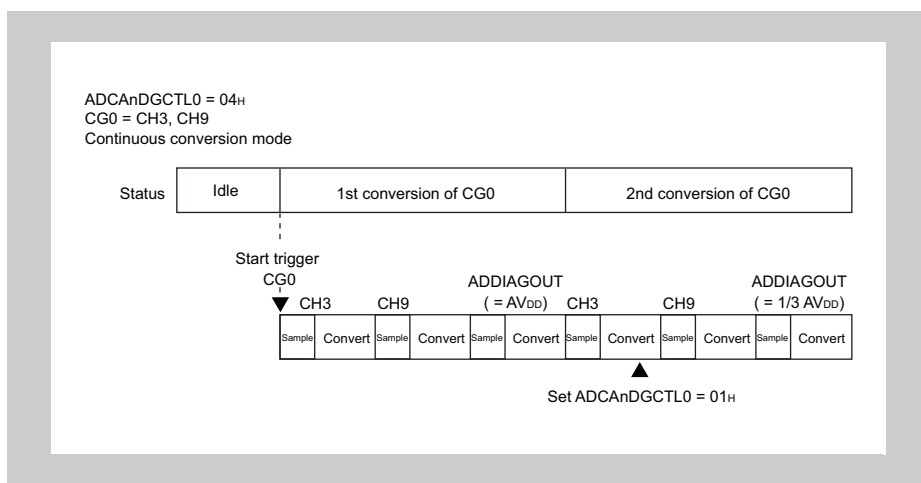

Figure 23-16 Writing during A/D Conversion

Note The value set in ADCAnDGCTL0.ADCAnPSEL[2:0] becomes valid after completion of current channel conversion. Therefore, set the reference voltage of the next diagnostic A/D conversion by the start of the conversion.

(2) Diagnosis of Channel Multiplexer

The ADCAn can diagnose if the switching and selection of channels work properly.

Each channel is assigned 1 of 3 reference voltages. The reference voltage values can be altered using ADCAnDGCTL0.ADCAnPSEL[2:0].

Table 23-5 Assignment of Reference Voltages to Channels

Reference Voltage	Channel
DIAGOUT0	18, 15, 12, 9, 6, 3
DIAGOUT1	16, 13, 10, 7, 4, 1
DIAGOUT2	17, 14, 11, 8, 5, 2

To diagnose the channel multiplexer, different reference voltages can be input to the channels.

The diagnosis voltage of channel multiplexer diagnostic is changed as the procedure below.

1. If conversion is under processing (ADCAnCTL0.ADCAnCE bit = 1), stop it (ADCAnCTL0.ADCAnCE bit = 0).
2. Set ADCAnDGCTL0.ADCAnPSEL[2:0] bits to 011_B.
3. Set ADCAnDGCTL0.ADCAnPSEL[2:0] bits to diagnosis voltage.

(3) Diagnosis of Analog Input Pins

Open input pins result in erroneous A/D conversion results.

The analog input ADCAnIm can be diagnosed connecting internal pull-down resistance.

For the internal pull-down resistance, refer to section 27.6.15, A/D Converter Characteristics.

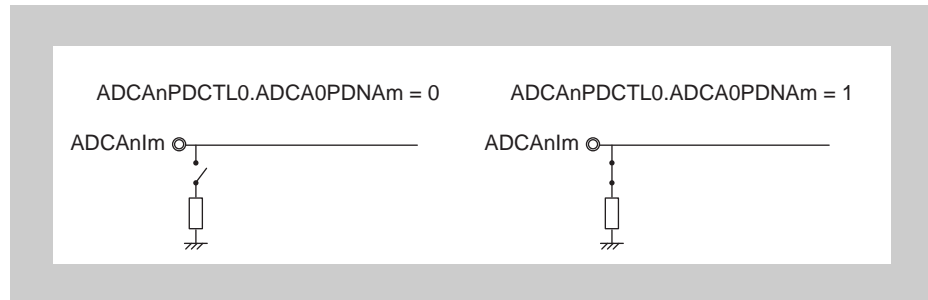

Figure 23-17 Internal Pull-down Resistors

When an internal pull-down resistor is connected to the analog input ADCAnIm (ADCAnPDCTL0.ADCA0PDNA_m = 1) and the ADCAnIm connection is open, the A/D conversion result approaches to 0 V.

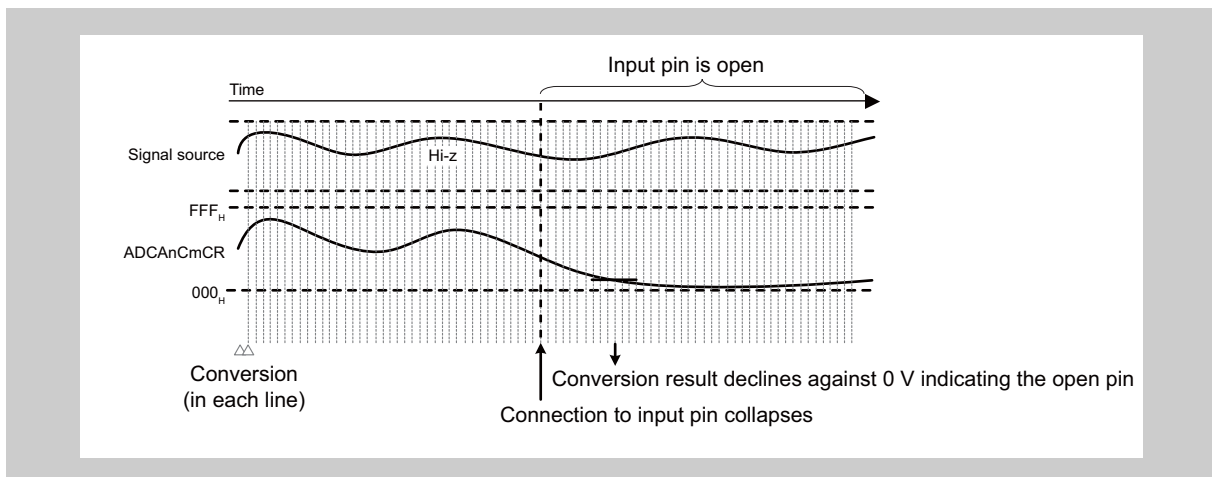

Figure 23-18 Detection of an open input pin

- Note 1. The pin being open circuit is not detectable if the ADCAnIm input voltage is less than 0.2 V.
- Note 2. Do not connect an internal pull-down resistor during normal A/D conversion operations. Connecting an internal pull-down resistor may lead to a drop in the input voltage, so that obtaining correct results of A/D conversion becomes impossible.

Diagnosis procedure (reference)

To diagnose open-circuit input pins:

1. Set discharge = ON, buffer amplifier = OFF, and channel S/H = OFF.
2. In the ADCA0PDCTL0 register, only specify a single channel as the target channel for diagnosis to detect the pin being open circuit. Setting the bit for the target channel for diagnosis to 1 enables connection of the pull-down resistor (typ. 450 kΩ) of the ANI buffer.
3. Only register a single channel from among the target channels for diagnosis to one of channel groups 0, 1, and 2.

4. Disable the hardware trigger for all channel groups by setting the ADCA0TSEL0, ADCA0TSEL1, and ADCA0TSEL2 registers, or the ADCA0T2ETS1 and ADCA0T2ETS0, ADCA0T1ETS1 and ADCA0T1ETS0, and ADCA0T0ETS1 and ADCA0T0ETS0 bits in the ADCA0CTL1 register. Also, control other channel groups so that conversion does not proceed during diagnosis to detect when the pin for the target channel is open circuit.
5. Set the registers to enable continuous A/D conversion on the target channel, and start conversion with either of the following methods.
 - When channel group 0 is to be used, specify continuous scan mode by setting ADCA0MD1 and ADCA0MD0 in ADCA0CTL1 to 01h before starting A/D conversion.
 - When channel group 1 or 2 is to be used, set TAUB to input a trigger signal at a fixed interval (the time for one A/D conversion), and set ADCA0TSEL1 or ADCA0TSEL2 to accept only the signal from TAUB as the trigger to start A/D conversion.
6. As continuous A/D conversion proceeds, transfer each result of conversion to another area (on-chip RAM) by interrupt processing or DMA. These data are used in determining the result of the diagnosis.
7. On completion of A/D conversion the specified number of times*, check the results of A/D conversion for values that decline to almost 0 V and are less than 0.2 V. If such values are found, the analog input pin for the target channel is judged to have been disconnected.
8. When multiple channels are to be targets for diagnosis, change the settings for the target channel in steps 2 and 3, then repeat steps 5 to 7.

Note 1. When AVDD = 5 V, calculate the number of times continuous conversion must proceed to detect an open-circuit pin (corresponding to the time taken for 5 V to change to 0.2 V due to the 15-pF pin capacitance) from the AD conversion time at the number of conversions required to make the total conversion time equal to at least 58 μ s.

The reference voltage (0.2 V) and total conversion time (58 μ s) are reference values. Those values must be fixed after exhaustive evaluation on the user system condition.

Caution The diagnostic function for the detection of open pins is designed for detecting the disconnection of analog input pins from the board and the disconnection of bonding wires; Due to the external capacitance, it cannot detect the disconnection of wiring on the sensor side.

(4) Diagnosis of Channel Sample and Hold Circuit

For the channel sample and hold function, refer to Section 23.3.12, Channel Sample and Hold Function.

The ADCAn can diagnose the channel sample and hold circuit. The outline is

Diagnosis of the sample and hold circuits of the channels in use is executed by following the procedures under “Step 1” and “Step 2” below (conversion when the channel’s sample and hold function is enabled or disabled) and using the DIAGOUT0 to DIAGOUT2 signals.

The following examples are for when channels 1, 2, 3 and 7 are in use.

Step 1 [Initial settings]

- Set the ADCAnCTL1.ADCAnGPS bit to 1 (power to ADCAn is on).
- Specify the start trigger as the software trigger and the mode of A/D conversion as one-shot conversion (CG0).
- Set the ADCAnIOC0 register to 0000 000E_H so that the A/D conversion end interrupt (INTADCAnT0) is generated. Set the ADCAnIOC1 register to 0000 0080_H so that the A/D conversion end interrupt (INTADCAnT1) is generated. Every time A/D conversion is completed, an interrupt must be generated.
- Set the ADCAnCG0 register to 0000 000E_H (selecting channels 1, 2, and 3).
- Set the ADCAnCG1 register to 0000 0080_H (selecting channel 7).
- Set the ADCAnDGCTL0.ADCAnPSEL[2:0] bits to 001_B (selecting 2/3 AV_{DD}, 1/3 AV_{DD} and 1/2 AV_{DD} as reference voltages DIAGOUT0, DIAGOUT1, and DIAGOUT2, respectively).
- Set the ADCAnDGCTL1 register to 0000 000E_H (selecting channels 1, 2, and 3 as the channels to which the internal reference voltage is applied).
- Set the ADCAnSHCTL register to 0000 0000_H (disabling channel S/H function).
- Set the ADCAnCTL0.ADCAnCE bit to 1 (enabling the A/D converter).

[Flow of operation]

- The software trigger starts A/D conversion of CG1 (channel 7).
- Input the conversion trigger for CG0 (the software trigger) during conversion on CG1, then set the ADCAnDGCTL0.ADCAnPSEL[2:0] bits to 010_B (selecting 1/2 AV_{DD}, 2/3 AV_{DD} and 1/3 AV_{DD} as reference voltages DIAGOUT0, DIAGOUT1, and DIAGOUT2, respectively).
Make the settings above before A/D conversion on CG1 is completed.
- When A/D conversion on channel 1 is completed, the A/D conversion end interrupt for CG0 (i.e. INTADCAnT0) is generated. If the circuit is operating normally, the result of conversion will be 2/3 AV_{DD}.
- When A/D conversion on channel 2 is completed, the A/D conversion end interrupt for CG0 (i.e. INTADCAnT0) is generated. If the circuit is operating normally, the result of conversion will be 1/3 AV_{DD}.
- When A/D conversion on channel 3 is completed, the A/D conversion end interrupt for CG0 (i.e. INTADCAnT0) is generated. If the circuit is operating normally, the result of conversion will be 1/2 AV_{DD}.

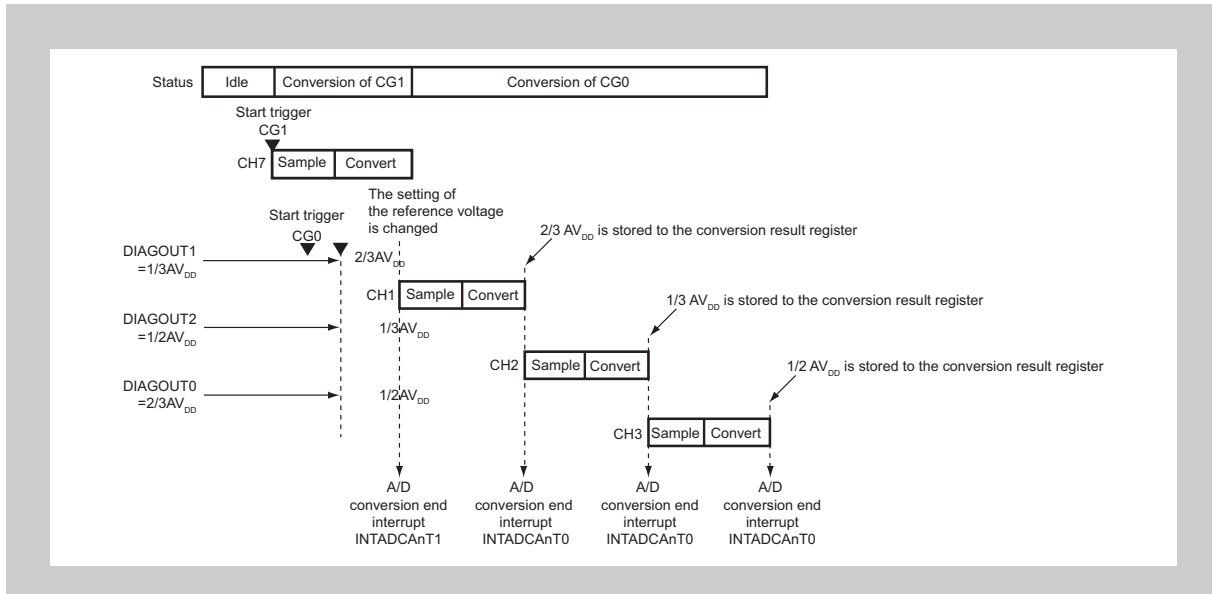

Step 2 [Initial settings]

- Set the ADCAnCTL1.ADCAnGPS bit to 1 (power to ADCAn is on).
- Specify the start trigger as the software trigger and the mode of A/D conversion as one-shot conversion (CG0).
- Set the ADCAnIOC0 register to 0000 000E_H so that the A/D conversion end interrupt (INTADCA nT0) is generated. Set the ADCAnIOC1 register to 0000 0080_H so that the A/D conversion end interrupt (INTADCA nT1) is generated. Every time A/D conversion is completed, an interrupt must be generated.
- Set the ADCAnCG0 register to 0000 000E_H (selecting channels 1, 2, and 3).
- Set the ADCAnCG1 register to 0000 0080_H (selecting channel 7).
- Set the ADCAnDGCTL0.ADCAnPSEL[2:0] bits to 001_B (selecting 2/3 AV_{DD}, 1/3 AV_{DD} and 1/2 AV_{DD} as reference voltages DIAGOUT0, DIAGOUT1, and DIAGOUT2, respectively).
- Set the ADCAnDGCTL1 register to 0000 000E_H (selecting channels 1, 2, and 3 as the channels to which the internal reference voltage is applied).
- Set the ADCAnSHCTL register to 0000 000E_H (enabling channel S/H function).
- Set the ADCAnCTL0.ADCAnCE bit to 1 (enabling the A/D converter).

[Flow of operations]

- The software trigger starts A/D conversion on CG1 (channel 7).
- Input the conversion trigger for CG0 (the software trigger) during conversion on CG1, then set the ADCAnDGCTL0.ADCAnPSEL[2:0] bits to 010_B (selecting 1/2 AV_{DD}, 2/3 AV_{DD} and 1/3 AV_{DD} as reference voltages DIAGOUT0, DIAGOUT1, and DIAGOUT2, respectively). Make the settings above before A/D conversion on CG1 is completed.
- When A/D conversion on channel 1 is completed, the A/D conversion end interrupt for CG0 (i.e. INTADCA nT0) is generated. If the circuit is operating normally, the result of conversion will be 1/3 AV_{DD}.

- When A/D conversion on channel 2 is completed, the A/D conversion end interrupt for CG0 (i.e. INTADCA_nT0) is generated. If the circuit is operating normally, the result of conversion will be $1/2 AV_{DD}$.
- When A/D conversion on channel 3 is completed, the A/D conversion end interrupt for CG0 (i.e. INTADCA_nT0) is generated. If the circuit is operating normally, the result of conversion will be $2/3 AV_{DD}$.

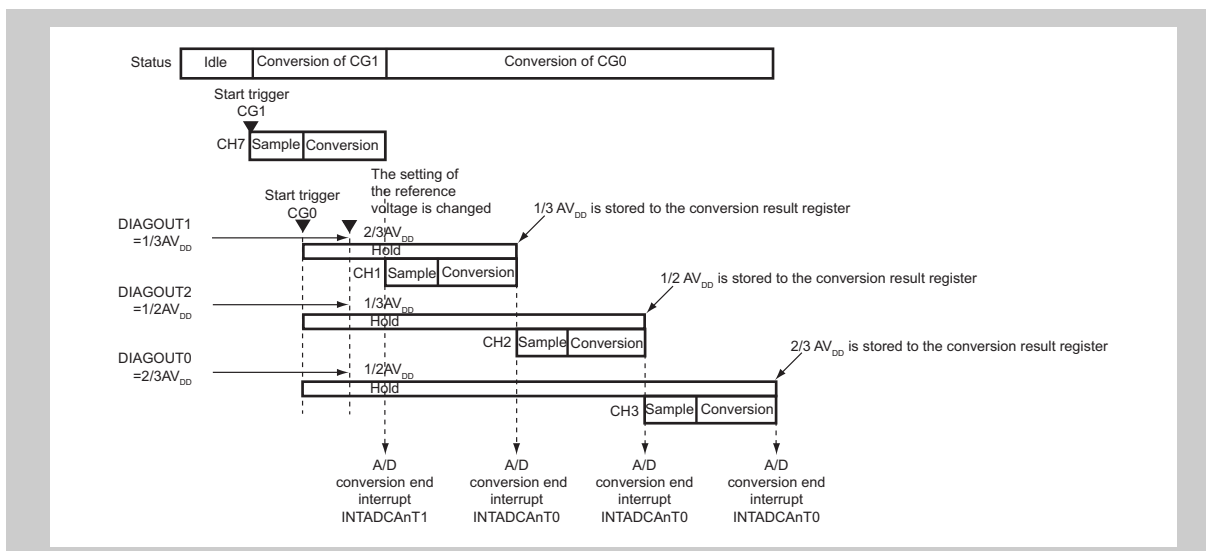

When the diagnosis voltage of channel S/H circuit diagnostic is changed, set ADCAnDGCTL0.ADCAnPSEL[2:0] bits to diagnosis voltage.

23.3.12 Channel Sample and Hold Function

(1) Channel Sample and Hold Function

The channel sample and hold circuit is shown below.

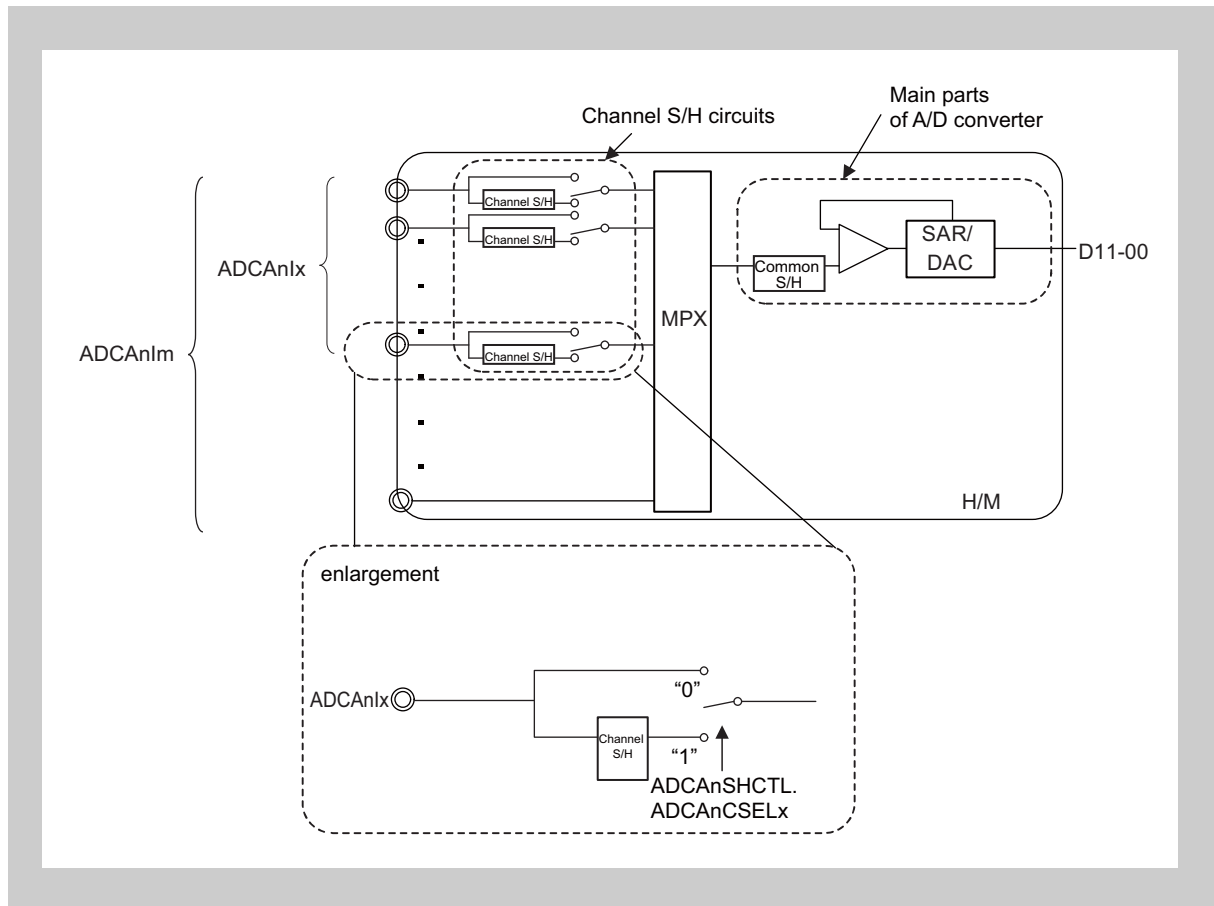

The channel sample and hold circuit can be used in one-shot conversion mode for CG0, CG1 and CG2 (no repetition).

The ADCAnSHCTL.ADCAnCSELx bit is used to enable or disable the channel sample and hold function.

When a hardware or software start trigger occurs, an analog input signal for a channel for which the sample and hold function is enabled using the ADCAnSHCTL.ADCAnCSELx bit is held in the channel sample and hold circuit. Then the scan list conversion is started according to the setting of the ADCAnCTL1.ADCAnTRMi bit.

Caution The sampling of channel sample and hold circuit is started by setting ADCAnCE bit to 1. Input the start trigger after waiting for the channel sample and hold sampling time (t_{CAS}) after setting ADCAnCE to 1. Because it is not satisfied the sampling specification for the channel S/H if the start trigger is input immediately after setting ADCAnCE bit to 1.

[Example 1: When a higher-priority start trigger occurs (ADCA_nTRM0 bit = 1, ADCA_nTRM1 bit = 1)]

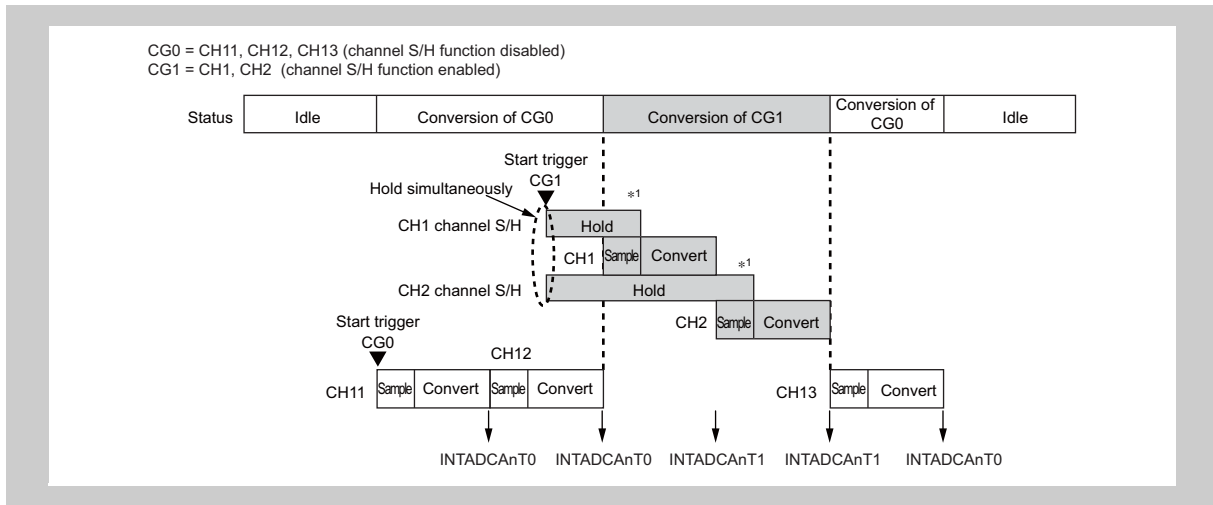

[Example 2: When a higher-priority start trigger occurs (ADCA_nTRM0 bit = 0, ADCA_nTRM1 bit = 0)]

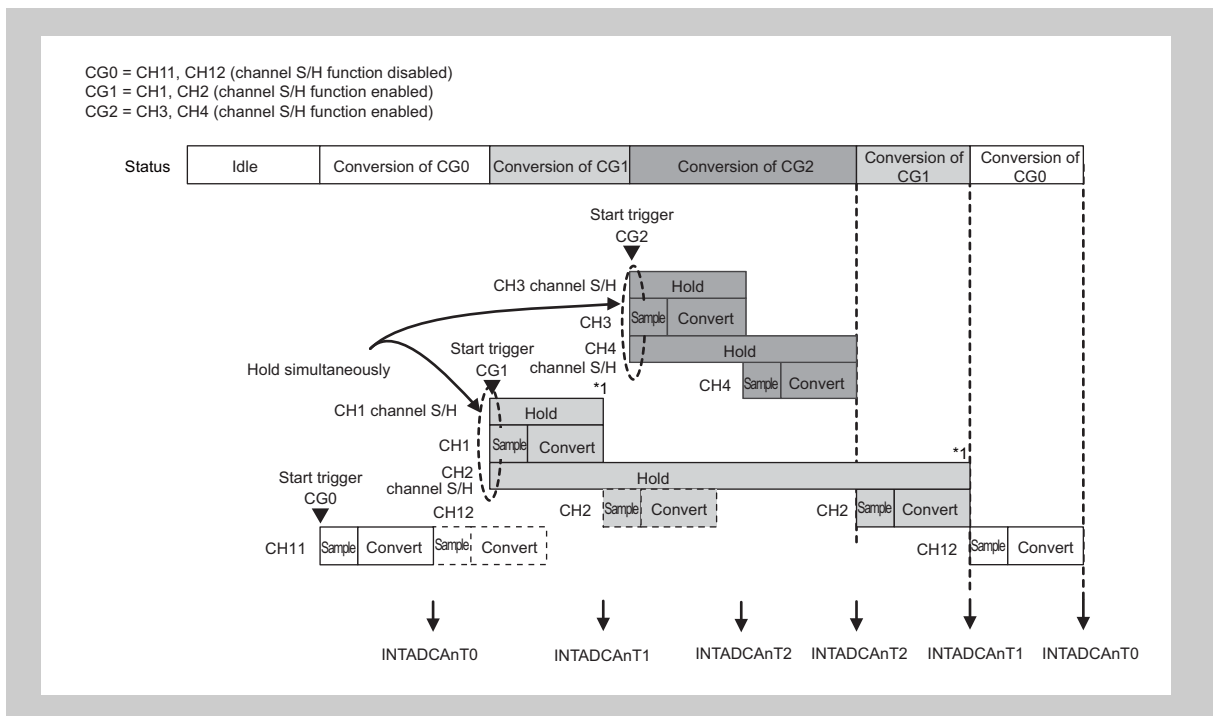

Note 1. When the ADCA_nTRM1 bit = 0, operation of the channel sample and hold circuit switches to sampling at this point.

[Example 3: When CG0 is in one-shot conversion mode (no repetition) (ADCA_nTRM0 bit = 0)]

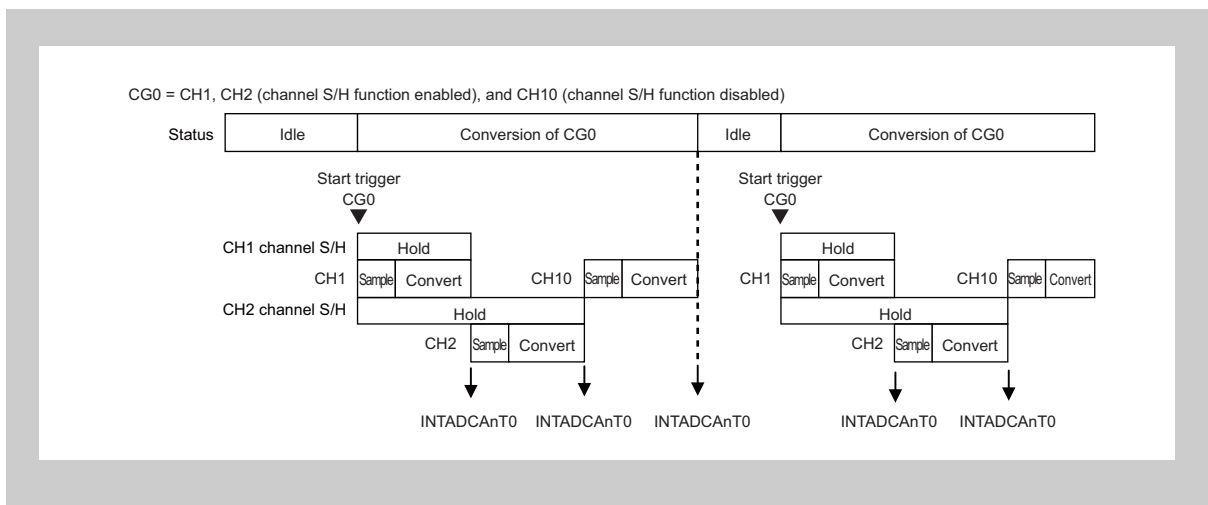

[Example 4: When CG0 is in one-shot conversion mode (no repetition) and a subsequent start trigger occurs (ADCA_nTRM0 bit = 0)]

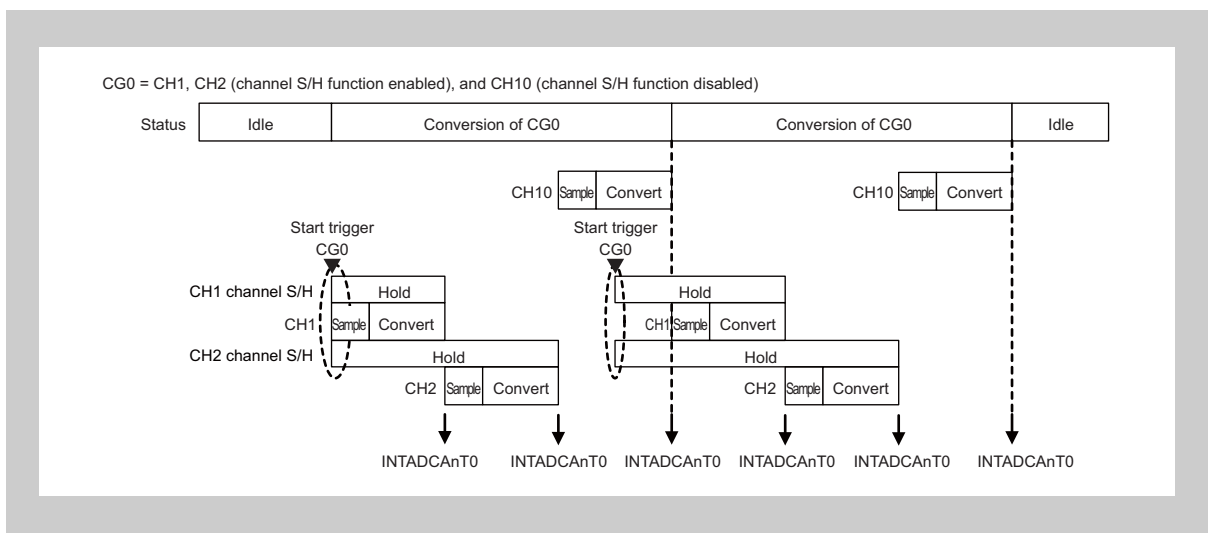

[Example 5: When CG0 is in one-shot conversion mode (no repetition) and a subsequent start trigger occurs (ADCA_nTRM0 bit = 1)]

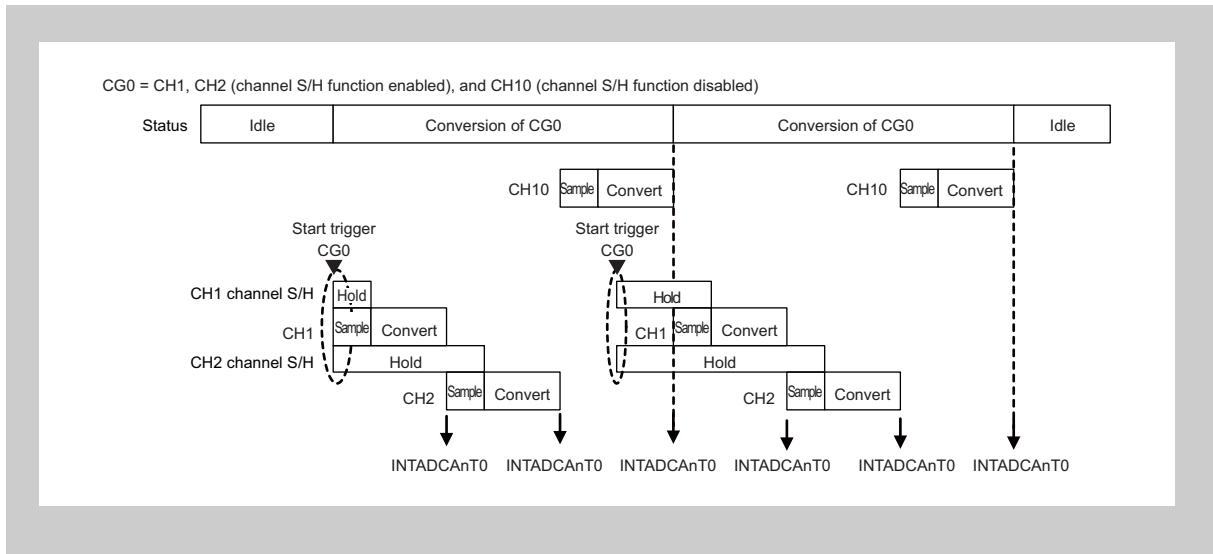

[Example 6: When CG0 is in continuous conversion mode and the same channels are set for CG0 and CG2 (ADCA_nTRM0 bit = 1)]

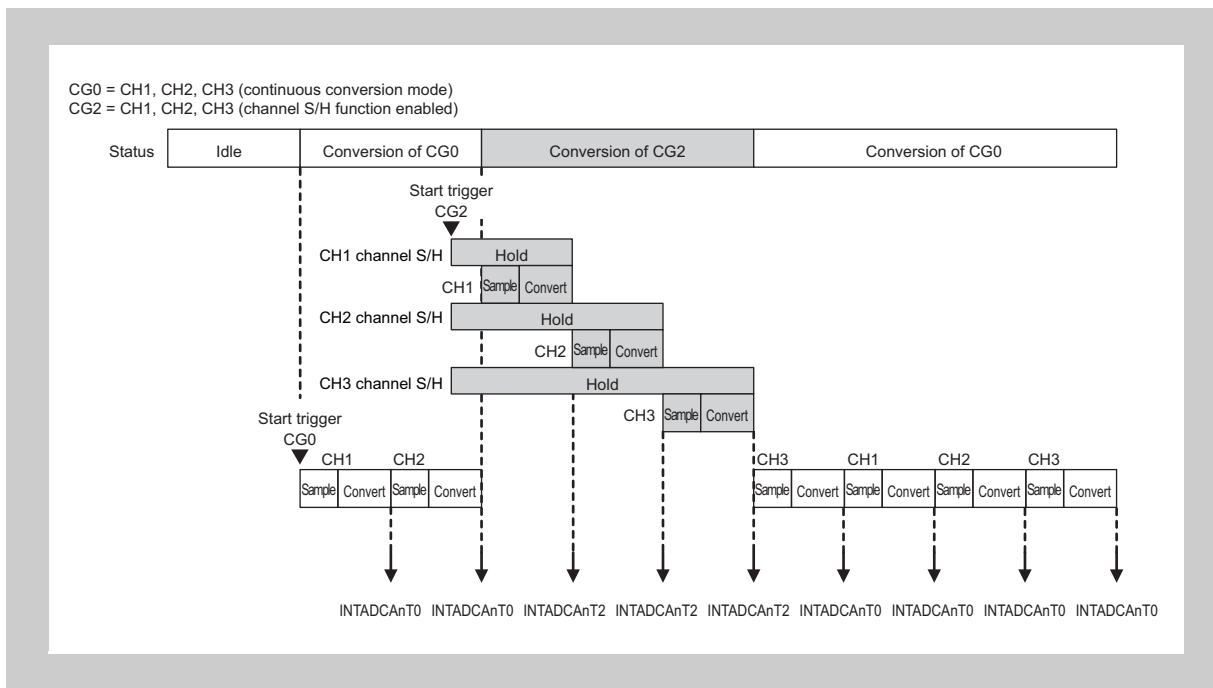

(2) Restrictions when Using Sample and Hold Function

Restrictions when using sample and hold function are as follows.

1. The channels to which the channel sample and hold function is applied must not be assigned to multiple CGs at the same time.

Example 1: When the channel sample and hold function is applied to CG0, CG1, and CG2 (CG0 in one-shot conversion mode)

The following combination is possible.

- CG0 (CH1 selected), CG1 (CH2 selected), and CG2 (CH3 selected)

The following combinations are prohibited.

- CG0 (CH1 selected), CG1 (CH1 selected), and CG2 (CH2 and CH3 selected)

Example 2: When the channel sample and hold function is applied to CG1 and CG2 (CG0 in continuous conversion mode)

The following combinations are possible.

- CG0 (CH1 selected), CG1 (CH1 and CH2 selected), and CG2 (CH3 selected)
- CG0 (CH1, CH2, and CH3 selected), CG1 (CH1 selected), and CG2 (CH2 and CH3 selected)

The following combination is prohibited.

- CG0 (CH1, CH2, and CH3 selected), CG1 (CH1 and CH2 selected), and CG2 (CH2 and CH3 selected)

2. When changing the scan list of CG_i to which the channel sample and hold function is applied during A/D conversion, set the scan list so that the channels for applying the function are not changed.

Example: When the channel sample and hold function is applied to CH1, CH2, and CH3.

The following changes are possible.

- Change from CG0 (CH1, CH2, and CH3) to CG0 (CH1, CH2, CH3, CH10, and CH11)
- Change from CG0 (CH1, CH2, CH3, CH10, and CH11) to CG0 (CH1, CH2, and CH3)
- Change from CG0 (CH7, CH8, and CH9) to CG0 (CH10, CH11, and CH12)

The following changes are prohibited.

- Change from CG0 (CH1, CH2, and CH3) to CG0 (CH1 and CH2)
- Change from CG0 (CH1) to CG0 (CH1, CH2, and CH3)
- Change from CG0 (CH7, CH8, and CH9) to CG0 (CH1, CH7, CH8, and CH9)
- Change from CG0 (CH1, CH2, and CH9) to CG0 (CH9, CH10, and CH11)

3. Repetition of A/D conversion is not available for CG to which the channel sample and hold function is applied. When the function is applied to CG_i, the repetition times setting bit (ADCA_nCTL0.ADCAnSCTI[1:0]) for the appropriate CG should be set to 00_B.

23.3.13 Discharge Function

If required, the internal capacitor in the common sample and hold circuit can be discharged prior to every A/D conversion.

Note When the discharge function is enabled, the total conversion time is increased (refer to Section 23.3.7, Resolution, Sampling Time and Conversion Time).

Setting The discharge function is enabled by setting ADCAnCTL1.DCAnDISC to 1.

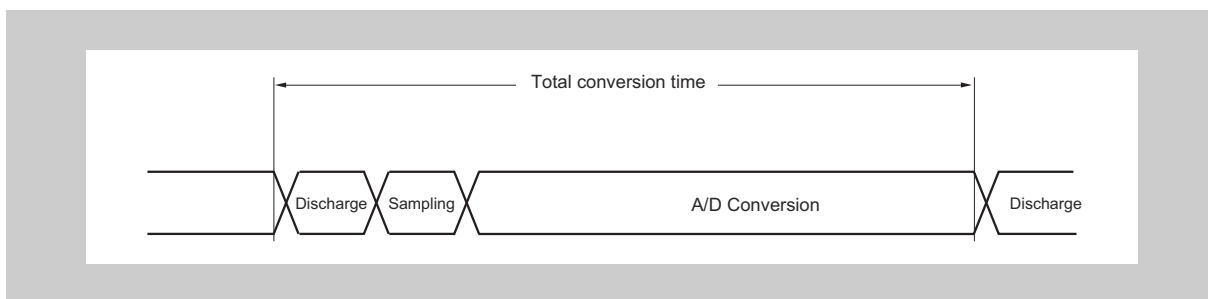

Figure 23-19 A/D Conversion Timing when Discharge Function is Enabled

23.3.14 Buffer Amplifier Function

If required, the analogue input signal can be connected to an internal buffer amplifier. Charging the internal sampling capacitor is accelerated by the buffer amplifier during sampling in A/D conversion.

The buffer amplifier function is enabled by setting `ADCAnCTL1.ADCAnBPC` to 1.

The buffer amplifier function is not available while a channel's sample-and-hold function is in use.

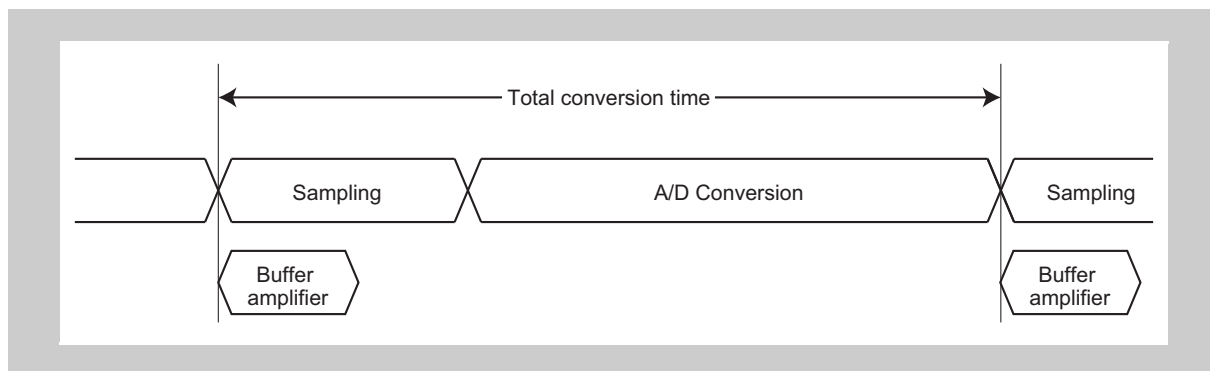

Figure 23-20 A/D Conversion Timing when Buffer Amplifier Function is Enabled

Caution In the channel with the channel S/H function enabled, the conversion is performed with the buffer amplifier function automatically being disabled.

23.3.15 Stabilization Control

The A/D converter needs time to stabilize operation at power on of the A/D converter (`ADCAnCTL1.ADCAnGPS = 1`).

Although a start trigger is acceptable even during the stabilization time, A/D conversion is not started before the stabilization time has elapsed.

In order to secure the minimum stabilization time, the setting of the stabilization time counter `ADCAnCNT` must be adapted. Refer to Section 23.4.2 (5), `ADCAnCNT` – A/D Converter Stabilization Counter for details.

23.4 Registers

This section contains a description of all the registers of the ADCAn.

23.4.1 ADCAn Registers Overview

The ADCAn is controlled and operated based on the settings of the registers in the following table.

- Where there is one register per channel, the channel number is represented by affix m.
- Where there is one register per CG, the CG number is represented by affix i (i = 0 to 2).

Table 23-6 List of ADCAn Registers (1/2)

Register Name	Symbol	Address
Control registers		
A/D converter mode control register 0	ADCAnCTL0	<ADCAn_base0> + 100 _H
A/D converter mode control register 1	ADCAnCTL1	<ADCAn_base0> + 104 _H
A/D converter CG register i	ADCAnCGi	<ADCAn_base1> + i × 4 _H
A/D converter interrupt control register i	ADCAnIOCi	<ADCAn_base1> + C _H + i × 4 _H
A/D converter trigger select control register i	ADCAnTSELi	<ADCAn_base0> + 108 _H + i × 4 _H
A/D converter stabilization counter	ADCAnCNT	<ADCAn_base0> + 114 _H
A/D converter sampling count register	ADCAnSMCNT	<ADCAn_base0> + 12C _H
A/D converter channel S/H wait count register	ADCAnSHWCNT	<ADCAn_base0> + 130 _H
A/D converter buffer amplifier count register	ADCAnAMPCNT	<ADCAn_base0> + 134 _H
A/D converter discharge count register	ADCAnDISCNT	<ADCAn_base0> + 138 _H
Conversion status registers		
A/D converter overwrite error flag register	ADCAnSTR1	<ADCAn_base1> + 28 _H
ADCAnSTR1 flag clear register	ADCAnSTC1	<ADCAn_base1> + 34 _H
A/D converter status flag register 2	ADCAnSTR2	<ADCAn_base1> + 2C _H
ADCAnSTR2 flag clear register	ADCAnSTC2	<ADCAn_base1> + 38 _H
Software trigger registers		
A/D converter software trigger register i	ADCAnTRGi	<ADCAn_base1> + A4 _H + i × 4 _H
A/D conversion result registers		
A/D converter latest conversion result register	ADCAnLCR	<ADCAn_base1> + A0 _H
A/D converter conversion result register m	ADCAnCmCR	<ADCAn_base1> + 3C _H + m × 4 _H
A/D converter CGi DMA buffer register i	ADCAnDBiCR	<ADCAn_base1> + C4 _H + i × 4 _H
A/D Converter CGi DMA Buffer Register i (Conversion Result)	ADCAnDBiCRL	<ADCAn_base1> + D0 _H + i × 4 _H
A/D converter diagnosis conversion result register	ADCAnDGCR	<ADCAn_base1> + 9C _H

Table 23-6 List of ADCAn Registers (2/2)

Register Name	Symbol	Address
A/D conversion result upper/lower limit comparison registers		
A/D conversion result check register	ADCAnCTL2	<ADCAn_base1> + 18 _H
A/D conversion result check (upper limit)	ADCAnUL	<ADCAn_base1> + 1C _H
A/D conversion result check (lower limit)	ADCAnLL	<ADCAn_base1> + 20 _H
A/D conversion result check error flag	ADCAnSTR0	<ADCAn_base1> + 24 _H
ADCAnSTR0 flag clear register	ADCAnSTC0	<ADCAn_base1> + 30 _H
Diagnosis function control registers		
A/D converter self-diagnosis function control register 0	ADCAnDGCTL0	<ADCAn_base1> + DC _H
A/D converter self-diagnosis function control register 1	ADCAnDGCTL1	<ADCAn_base0> + 11C _H
A/D converter internal pull-down resistance control register 0	ADCAnPDCTL0	<ADCAn_base0> + 120 _H
Channel S/H function setting register		
A/D converter channel S/H control register	ADCAnSHCTL	<ADCAn_base0> + 118 _H

23.4.2 Control Registers

(1) ADCAnCTL0 – A/D Converter Mode Control Register 0

This register enables/disables the A/D converter. Additionally it specifies the number of repetition times and the mode of repetition for A/D conversion in one-shot conversion mode and the generation of error interrupt requests when an A/D conversion result is overwritten before it was read.

Access This register can be read/written in 16-bit units.
It can only be written when the A/D converter is disabled (ADCAnCTL0.ADCAnCE = 0) (excluding clear of the bit).

Address <ADCAn_base0> + 100_H

Initial value 0000_H

This register is initialized by any reset.

15	14	13	12	11	10	9	8	7	6	5	4	3	2	1	0
0	0	0	ADCAn OEM4	ADCAnOEM[3:1]			ADCAn OEM0	ADCAn CE	ADCAn STM	ADCAn SCT2[1:0]		ADCAn SCT1[1:0]		ADCAn SCT0[1:0]	
R	R	R	R/W	R/W	R/W	R/W	R/W	R/W	R/W	R/W	R/W	R/W	R/W	R/W	R/W

Table 23-7 ADCAnCTL0 Register Contents (1/2)

Bit Position	Bit Name	Function
12	ADCAn OEM4	Specifies whether the error interrupt INTADCAnTERR is generated when an A/D conversion result in ADCAnLCR is overwritten before it is read: 0: Generates the error interrupt INTADCAnTERR when an A/D conversion result is overwritten 1: Does not generate the error interrupt INTADCAnTERR For details, refer to Section 23.3.10 (1), Overwrite Check for A/D Conversion Results
11 to 9	ADCAn OEM[3:1]	Specifies whether the error interrupt INTADCAnTERR is generated when an A/D conversion result in any ADCAnDBiCR is overwritten before it is read: 0: Generates the error interrupt INTADCAnTERR when an A/D conversion result is overwritten 1: Does not generate the error interrupt INTADCAnTERR CGi is controlled by the ADCAnOEM (i + 1) bit For details, refer to Section 23.3.10 (1), Overwrite Check for A/D Conversion Results.
8	ADCAn OEM0	Specifies whether the error interrupt INTADCAnTERR is generated when an A/D conversion result in any ADCAnCmCR is overwritten before it is read: 0: Generates the error interrupt INTADCAnTERR when an A/D conversion result is overwritten 1: Does not generate the error interrupt INTADCAnTERR For details, refer to Section 23.3.10 (1), Overwrite Check for A/D Conversion Results.

Table 23-7 ADCAnCTL0 Register Contents (2/2)

Bit Position	Bit Name	Function															
7	ADCAnCE	<p>Enables or disables the A/D converter: 0: Disables the A/D converter 1: Enables the A/D converter</p> <p>This bit must be set to 1 separately from other bits. The A/D conversion is started by generating a hardware or software start trigger (using bit ADCAnTRGi.ADCAnSTTi) after setting the ADCAnCTL0.ADCAnCE bit to 1. Although a hardware or software start trigger is acceptable immediately after power on using bit ADCAnCTL1.ADCAnGPS (during the stabilization time), A/D conversion is not started before the stabilization time has elapsed. After the stabilization time, A/D conversion is started. When the A/D converter is enabled and then disabled, the procedure is as follows.</p> <ol style="list-style-type: none"> 1. Set the ADCAnCTL1.ADCAnTiETS[1:0] bits to 00B. (The valid edge of the HW conversion trigger is not detected.) 2. Wait for one cycle. 3. ADCAnCTL0.ADCAnCE = 0 (AD conversion stopped) <p>When the enable/disable is switched, the value retained to conversion result registers (ADCAnDGCR, ADCAnLCR, ADCAnCmCR and ADCAnDBiCR) are initialized.</p>															
6	ADCAnSTM	<p>This bit specifies the mode of repetition for one-shot conversion. 0: Channel repetition mode is not used. 1: Channel repetition mode is used.</p> <p>Conversion is repeated on each channel in turn the number of times specified by the ADCAnSCTi[1:0] bits. Example: When CGi = {1, 2, and 3} and the ADCAnSCTi[1:0] bits are 10_B In channel repetition mode, conversion is in the following order: channel 1 → channel1 → channel1 → channel 2 → channel 2 → channel 2 → channel 3 → channel 3 → channel 3</p> <p>Note: When ADCAnSTM = 0, set the number of repetitions (the ADCAnSCTi [1:0] bits) to 1 (00_B).</p>															
5 to 0	ADCAnSCTi[1:0]	<p>Number of times the scan list conversions of CG0, CG1, and CG2 are repeated in one-shot conversion mode</p> <table border="1"> <thead> <tr> <th>ADCAnSCTi1</th> <th>ADCAnSCTi0</th> <th>Number of Repetitions of Scan List Conversions of CGi</th> </tr> </thead> <tbody> <tr> <td>0</td> <td>0</td> <td>1</td> </tr> <tr> <td>0</td> <td>1</td> <td>2</td> </tr> <tr> <td>1</td> <td>0</td> <td>3</td> </tr> <tr> <td>1</td> <td>1</td> <td>4</td> </tr> </tbody> </table>	ADCAnSCTi1	ADCAnSCTi0	Number of Repetitions of Scan List Conversions of CGi	0	0	1	0	1	2	1	0	3	1	1	4
ADCAnSCTi1	ADCAnSCTi0	Number of Repetitions of Scan List Conversions of CGi															
0	0	1															
0	1	2															
1	0	3															
1	1	4															

(2) ADCAnCTL1 – A/D Converter Mode Control Register 1

This register specifies the A/D conversion mode and controls the conversion operations.

Access This register can be read/written in 32-bit units.
It can only be written when the A/D converter is disabled (ADCAnCTL0.ADCAnCE = 0).

Address <ADCAn_base0> + 104_H

Initial value 0100 0000_H

This register is initialized by any reset.

31	30	29	28	27	26	25	24	23	22	21	20	19	18	17	16
ADCAn T2ETS[1:0]	ADCAn T1ETS[1:0]	ADCAn T0ETS[1:0]	0	ADCAn CRAC	0	0	ADCAn MD1	ADCAn MD0	0	0	ADCAn DISC	ADCAn RCL			
R/W	R/W	R/W	R/W	R/W	R/W	R	R/W	R	R	R/W	R/W	R	R	R/W	R/W
15	14	13	12	11	10	9	8	7	6	5	4	3	2	1	0
ADCAn CTYP	0	0	ADCAn STL	0	0	ADCAnFR [1:0]	0	0	ADCAn TRM[1:0]	ADCAn BPC	0	0	ADCAn GPS		
R/W	R	R	R/W	R	R	R/W	R/W	R	R	R/W	R/W	R/W	R	R	R/W

Table 23-8 ADCAnCTL1 Register Contents (1/2)

Bit Position	Bit Name	Function															
31 to 26	ADCAn TiETS[1:0]	Specifies the valid edge of the hardware trigger signal ADCAnTTRGi. <table border="1"> <thead> <tr> <th>ADCAn TiETS1</th><th>ADCAn TiETS0</th><th>Valid Edge</th></tr> </thead> <tbody> <tr> <td>0</td><td>0</td><td>No edge detection (trigger is not accepted)</td></tr> <tr> <td>0</td><td>1</td><td>Rising edge</td></tr> <tr> <td>1</td><td>0</td><td>Falling edge</td></tr> <tr> <td>1</td><td>1</td><td>Rising and falling edges</td></tr> </tbody> </table>	ADCAn TiETS1	ADCAn TiETS0	Valid Edge	0	0	No edge detection (trigger is not accepted)	0	1	Rising edge	1	0	Falling edge	1	1	Rising and falling edges
ADCAn TiETS1	ADCAn TiETS0	Valid Edge															
0	0	No edge detection (trigger is not accepted)															
0	1	Rising edge															
1	0	Falling edge															
1	1	Rising and falling edges															
24	ADCAn CRAC	Specifies the alignment of the results of A/D conversion and diagnosis conversion: 0: Right-aligned 1: Left-aligned															
21	ADCAn MD1	Specifies the A/D conversion start trigger for CG0 0: Software trigger 1: Hardware and software triggers This setting is applied to the A/D conversion of CG0 only. CG1 and CG2 always accept both hardware and software triggers. The A/D converter detects triggers only when the A/D converter is enabled. For details, refer to Section 23.3.5, Starting A/D Conversion (Start Triggers).															
20	ADCAn MD0	Specifies the A/D conversion mode for CG0: 0: One-shot conversion mode The number of repetitions is set in ADCAnCTL0.ADCAnSCTi[1:0] for each CG. 1: Continuous conversion mode This setting applies to the A/D conversion of CG0 only. CG1 and CG2 always operate in one-shot conversion mode. For details, refer to Section 23.3.4, A/D Conversion Modes.															

Table 23-8 ADCAnCTL1 Register Contents (2/2)

Bit Position	Bit Name	Function										
17	ADCAn DISC	Enables/disables the discharge function 0: Disable 1: Enable For details, refer to Section 23.3.13, Discharge Function.										
16	ADCAn RCL	Specifies whether the A/D conversion result in ADCAnCmCR, ADCAnDBiCR, or ADCAnDBiCRL is retained after being read: 0: The A/D conversion result is retained until it is overwritten by the next A/D conversion result 1: The A/D conversion result is cleared after being read										
15	ADCAn CTYP	Specifies the resolution mode 0: 12-bit resolution 1: 10-bit resolution										
12	ADCAn STL	Specifies the level of the ADCAnCNVi signal 0: When ADCAnCNVi = low, CGi is not currently performing conversion When ADCAnCNVi = high, CGi is currently performing conversion 1: When ADCAnCNVi = high, CGi is not currently performing conversion When ADCAnCNVi = low, CGi is currently performing conversion										
9, 8	ADCAn FR[1:0]	Specifies the ADCAn system clock ADCAnTCLK For setting values, refer to Section 23.3.7, Resolution, Sampling Time and Conversion Time. <table border="1" data-bbox="558 945 1382 1160"> <thead> <tr> <th>ADCAnFR[1:0]</th> <th>ADCAn Clock</th> </tr> </thead> <tbody> <tr> <td>00</td> <td>PCLK</td> </tr> <tr> <td>01</td> <td>PCLK/2</td> </tr> <tr> <td>10</td> <td>Setting prohibited</td> </tr> <tr> <td>11</td> <td>Setting prohibited</td> </tr> </tbody> </table> <p>The limits on the frequency of ADCAnTCLK are as follows: 48 MHz (max.) and 16 MHz (min.)</p>	ADCAnFR[1:0]	ADCAn Clock	00	PCLK	01	PCLK/2	10	Setting prohibited	11	Setting prohibited
ADCAnFR[1:0]	ADCAn Clock											
00	PCLK											
01	PCLK/2											
10	Setting prohibited											
11	Setting prohibited											
5 to 4	ADCAn TRM[1:0]	Specifies the interrupt behavior when the A/D conversion of a higher-priority CG is triggered. The settings in ADCAnTRM1 and ADCAnTRM0 apply to CG1 and CG0, respectively. The setting of CG2 is always 0. 0: Halts the current A/D conversion of CGi immediately, and starts the A/D conversion of the higher-priority CG (immediately halts the A/D conversion due to a higher-priority trigger, holds the current conversion status so that the conversion can be resumed later, and releases the hold state upon completion of the higher-priority A/D conversion). 1: Halts the A/D conversion of CGi after the conversion of the current channel is completed, and starts the A/D conversion of the higher-priority CG (even if a higher-priority trigger is generated, the A/D conversion is suspended until conversion completion of the current channel; therefore the hold state of the trigger signal is released upon completion of sampling). After the A/D conversions of all the higher-priority CGs are finished, the A/D conversion of CGi is resumed. The priority order is: CG2 > CG1 > CG0. For details, see Section 23.3.3 (1), Order of A/D Conversion.										
3	ADCAn BPC	Enables/disables the buffer amplifier function: 0: Disable 1: Enable The initial value is 0. For details, see Section 23.3.14, Buffer Amplifier Function.										
0	ADCAn GPS	Powers on or off the ADCAn 0: Power off 1: Power on The AD converter needs time to stabilize its operation after being powered on (refer to Section 23.3.15, Stabilization Control).										

(3) ADCAnCGi – A/D Converter Channel Group Register i

This register makes a scan list for each CG. Channels included in the scan list are converted in ascending order. For details, refer to Section 23.3.3, Channel and Channel Group.

This register can also enable or disable the diagnostic A/D conversion which uses the reference voltage signal ADDIAGOUT, by using ADCAnCG0.ADCAnDIAG. For details, refer to Section 23.3.11 (1), Diagnosis of A/D Conversion Circuit.

Access This register can be read/written in 32-bit units. Since this register uses master/slave configuration, the next A/D conversion channel can be set in the master register during current A/D conversion. The value in the master register is transferred to the slave register at the following timing:

- When CGi is not currently performing A/D conversion, the value is transferred 1 clock cycle (PCLK) after it is written in the master register.
- When CGi is currently performing A/D conversion, the value is transferred upon completion of the scan list conversion of the current CGi.

Address <ADCAn_base1> + i × 4_H

Initial value 0000 0000_H

This register is initialized by any reset.

31	30	29	28	27	26	25	24	23	22	21	20	19	18	17	16
ADCAn DIAG	0	0	0	0	0	0	0	ADCAnCGiS[23:16]							
R/W	R	R	R	R	R	R	R	R/W	R/W	R/W	R/W	R/W	R/W	R/W	R/W
15	14	13	12	11	10	9	8	7	6	5	4	3	2	1	0
ADCAnCGiS[15:00]															
R/W	R/W	R/W	R/W	R/W	R/W	R/W	R/W	R/W	R/W	R/W	R/W	R/W	R/W	R/W	R/W

Table 23-9 ADCAnCGi Register Contents

Bit Position	Bit Name	Function
31	ADCAn DIAG	Enables or disables the diagnostic A/D conversion of the reference voltage signal ADDIAGOUT at the end of the A/D conversion of CG0: 0: Disables A/D conversion of ADDIAGOUT 1: Converts ADDIAGOUT This bit only applies to ADCAnCG0. This bit should be set to 0 in ADCAnCG1 and ADCAnCG2.
23 to 00	ADCAn CGiS[23:00]	Specifies the analog inputs to be converted for CGi: 0: Does not convert analog input ADCAnIm 1: Converts analog input ADCAnIm Note: The bits corresponding to the channels that are not implemented in this product should be cleared to 0 (for the applicable bits, refer to the Number of analog input pins fields in the table in Section 23.1, ADCA Features).

(4) ADCAnIOCi – A/D Converter Interrupt Control Register i

The A/D conversion end interrupt INTADCAnTi can be generated when the A/D conversion of a certain channel has been completed.

This register specifies the channels for which INTADCAnTi is generated on A/D conversion completion.

If ADCAnIOCi = 0000 0000_H, INTADCAnTi is automatically generated at the completion of A/D conversion of CGi.

Access This register can be read/written in 32-bit units. It can be written at any time even when the A/D converter is enabled (ADCAnCTL0.ADCAnCE = 1). The new value takes effect after the current A/D conversion of CGi has been completed.

Address <ADCAn_base1> + 0C_H + i × 4_H

Initial value 0000 0000_H

This register is initialized by any reset.

31	30	29	28	27	26	25	24	23	22	21	20	19	18	17	16
ADCAn CG0 IDG	0	0	0	0	0	0	0	ADCAnCGil[23:16]							
R/W	R	R	R	R	R	R	R	R/W	R/W	R/W	R/W	R/W	R/W	R/W	R/W
15	14	13	12	11	10	9	8	7	6	5	4	3	2	1	0
ADCAnCGil[15:00]															
R/W	R/W	R/W	R/W	R/W	R/W	R/W	R/W	R/W	R/W	R/W	R/W	R/W	R/W	R/W	R/W

Table 23-10 ADCAnIOCi Register Contents

Bit Position	Bit Name	Function
31	ADCAn CG0IDG	Specifies whether the interrupt INTADCAnTi is generated on completion of the A/D conversion of the reference voltage when the diagnostic mode is enabled for CG0 (ADCAnCG0.ADCAnDIAG = 1): 0: Does not generate the A/D conversion end interrupt INTADCAnTi 1: Generates the A/D conversion end interrupt INTADCAnTi This bit only applies to ADCAnIOC0. This bit should be cleared to 0 in ADCAnIOC1 and ADCAnIOC2. For details, refer to Section 23.3.11 (1), Diagnosis of A/D Conversion Circuit.
23 to 00	ADCAn CGil[23:00]	Specifies whether or not the interrupt INTADCAnTi is generated on A/D conversion completion of channel m: 0: Does not generate the A/D conversion end interrupt INTADCAnTi 1: Generates the A/D conversion end interrupt INTADCAnTi Note: The bits corresponding to the channels that are not implemented in this product should be cleared to 0 (for the applicable bits, refer to the Number of analog input pins fields in the table in Section 23.1, ADCA Features).

Note ADCAnIOCi is associated with ADCAnCGi and their buffer registers should be updated simultaneously. As the update time depends on writing to ADCAnCGi, always write to ADCAnIOCi before ADCAnCGi if you want to change the interrupt generation for a CG.

(5) ADCAnCNT – A/D Converter Stabilization Counter

This register specifies the stabilization time.

Access This register can be read/written in 8-bit units.
It can only be written when the A/D converter is disabled (ADCAnCTL0.ADCAnCE = 0).

Address <ADCAn_base0> + 114_H

Initial value 00_H

This register is initialized by any reset.

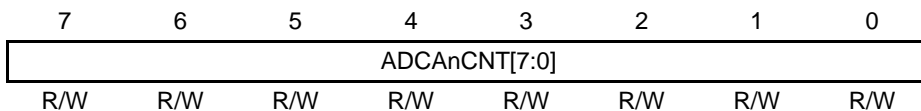

Table 23-11 ADCAnCNT Register Contents

Bit Position	Bit Name	Function
7 to 0	ADCAnCNT [7:0]	Specifies the stabilization counter: Stabilization time = 8192 × ADCAnCNT[7:0] × clock cycles (PCLK)

Note The value of stabilization counter should be set so that the stabilization time is 10 ms or more.

(6) ADCAnTSELi – A/D Converter Trigger Select Control Register 0

This register specifies the input signals to be used in combination with hardware start triggers ADCAnTTRGi. Multiple trigger sources can be used simultaneously.

Access This register can be read/written in 16-bit units. It can only be written when the A/D converter is disabled (ADCAnCTL0.ADCAnCE = 0).

Address <ADCAn_base0> + 108_H + i × 4_H

Initial value 0000_H

This register is initialized by any reset.

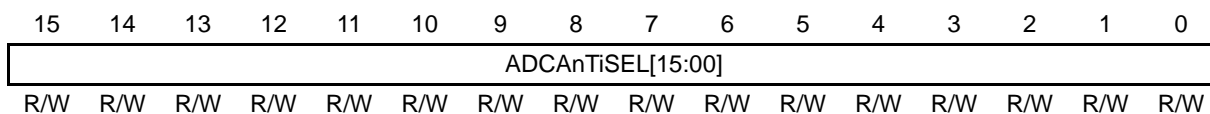

Table 23-12 ADCAnTSELi Register Contents

Bit Position	Bit Name	Function
15 to 0	ADCAnTiSEL [15:00]	Specifies whether the corresponding input signal is to be used as hardware start trigger. 0: Not used as hardware start trigger 1: Used as hardware start trigger Note: The bits corresponding to the triggers that are not implemented in this product should be cleared to 0.

Note For units to which the hardware trigger signals are connected, refer to Table 23-2, Units to which Hardware Trigger Signals are Connected.

(7) ADCAnSMCNT - A/D Converter Sampling Count Register

This register specifies the sum of discharge time and sampling time.

Access This register can be read/written in 8-bit units.
It can only be written when the A/D converter is disabled (ADCAnCTL0.ADCAnCE = 0).

Address <ADCAn_base0> + 12C_H

Initial value 3C_H

This register is initialized by any reset.

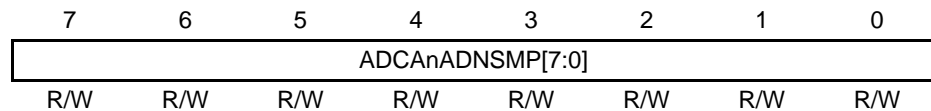

Table 23-13 ADCAnSMCNT Register Contents

Bit Position	Bit Name	Function
7 to 0	ADCAnADNSMP [7:0]	Specifies the sum of discharge time and sampling time. For detail of the times, see Table 23-3, Total Conversion Times (10- and 12-bit Resolution)

(8) ADCAnSHHCNT - A/D Converter Channel S/H Wait Count Register

Specifies the time after the analog input is sampled until the value held is output to the common S/H circuit. Set this register, when the channel S/H function is enabled. If it is disabled, setting this register is ignored.

Access This register can be read/written in 8-bit units.
It can only be written when the A/D converter is disabled (ADCAnCTL0.ADCAnCE = 0).

Address <ADCAn_base0> + 130_H

Initial value 0A_H

This register is initialized by any reset.



Table 23-14 ADCAnSHHCNT Register Contents

Bit Position	Bit Name	Function
4 to 0	ADCAnSHHCNT [4:0]	Specifies the hold wait time of channel S/H. For detail of the times, see Table 23-3, Total Conversion Times (10- and 12-bit Resolution)

(9) ADCAnAMPCNT - A/D Converter Buffer Amplifier Count Register

This register specifies the operation time of the buffer amplifier. Set this register, when the buffer amplifier function is enabled. If it is disabled, setting this register is ignored.

Access This register can be read/written in 8-bit units.
It can only be written when the A/D converter is disabled (ADCAnCTL0.ADCAnCE = 0).

Address <ADCAn_base0> + 134_H

Initial value 0C_H

This register is initialized by any reset.

7	6	5	4	3	2	1	0
0	0	0	0	ADCAnAMPCNT[3:0]			
R	R	R	R	R/W	R/W	R/W	R/W

Table 23-15 ADCAnAMPCNT Register Contents

Bit Position	Bit Name	Function
3 to 0	ADCAn AMPCNT [3:0]	These bits specify the operation time of the buffer amplifier. For detail of the times, see Table 23-3, Total Conversion Times (10- and 12-bit Resolution)

(10) ADCAnDISCNT - A/D Converter Discharge Count Register

This register specifies the discharge time. Set this register, when the discharge function is enabled. If it is disabled, setting this register is ignored.

Access This register can be read/written in 8-bit units.
It can only be written when the A/D converter is disabled (ADCAnCTL0.ADCAnCE = 0).

Address <ADCAn_base0> + 138_H

Initial value 0F_H

This register is initialized by any reset.

7	6	5	4	3	2	1	0
0	0	0	0	ADCAnDISCNT[3:0]			
R/W	R/W	R/W	R/W	R/W	R/W	R/W	R/W

Table 23-16 ADCAnDISCNT Register Contents

Bit Position	Bit Name	Function
3 to 0	ADCAn DISCNT [3:0]	These bits specify the discharge time. For detail of the times, see Table 23-3, Total Conversion Times (10- and 12-bit Resolution)

23.4.3 Conversion Status Registers

(1) ADCAnSTR1 – A/D Converter Overwrite Error Flag

This register indicates whether the latest A/D conversion result in ADCAnCmCR has been overwritten before it is read.

Access This register can be read in 32-bit units.

Address <ADCAn_base1> + 28_H

Initial value 0000 0000_H

This register is initialized by any reset.

31	30	29	28	27	26	25	24	23	22	21	20	19	18	17	16
0	0	0	0	0	0	0	0	ADCAnOWE[23:16]							
R	R	R	R	R	R	R	R	R	R	R	R	R	R	R	R
15	14	13	12	11	10	9	8	7	6	5	4	3	2	1	0
ADCAnOWE[15:00]															
R	R	R	R	R	R	R	R	R	R	R	R	R	R	R	R

Table 23-17 ADCAnSTR1 Register Contents

Bit Position	Bit Name	Function
23 to 0	ADCAnOWE[23:00]	Indicates whether the A/D conversion result of channel m has been overwritten before it is read. 0: Not overwritten 1: Overwritten This error flag is cleared by setting ADCAnSTC1.ADCAnOWECm to 1. Note: The bits corresponding to the channels that are not implemented in this product should be cleared to 0 (for the applicable bits, refer to the Number of analog input pins fields in the table in Section 23.1, ADCA Features).

Note The value of ADCAnSTR1.ADCAnOWEm is reflected in the following overwrite error flag:

- The error flag in the A/D converter conversion result register for channel m (ADCAnCmCR.ADCAnCmER1)

(2) ADCAnSTC1 – ADCAnSTR1 Flag Clear Register

This register is the clear control register for ADCAnSTR1.

Access This register can be written in 32-bit units.

It is always read as 0000 0000_H.

Address <ADCAn_base1> + 34_H

Initial value 0000 0000_H

This register is initialized by any reset.

31	30	29	28	27	26	25	24	23	22	21	20	19	18	17	16
0	0	0	0	0	0	0	0	ADCAnOWEC[23:16]							
W	W	W	W	W	W	W	W	W	W	W	W	W	W	W	W
15	14	13	12	11	10	9	8	7	6	5	4	3	2	1	0
ADCAnOWEC[15:00]															
W	W	W	W	W	W	W	W	W	W	W	W	W	W	W	W

Table 23-18 ADCAnSTC1 Register Contents

Bit Position	Bit Name	Function
23 to 0	ADCAnOWEC [23:00]	Clears the A/D converter overwrite error flag (ADCAnSTR1.ADCAnOWEm bit). 0: No effect (writing 0 to a bit does not affect the corresponding A/D converter overwrite error flag, i.e. the ADCAnSTR1.ADCAnOWEm bit). 1: Clears ADCAnSTR1.ADCAnOWEm Note: The bits corresponding to the channels that are not implemented in this product should be cleared to 0 (for the applicable bits, refer to the Number of analog input pins fields in the table in Section 23.1, ADCA Features).

(3) ADCAnSTR2 – A/D Converter Status Flag 2

This register indicates the current conversion status.

Access This register can be read in 16-bit units.

Address <ADCAn_base1> + 2C_H

Initial value 0000_H

This register is initialized by any reset.

15	14	13	12	11	10	9	8	7	6	5	4	3	2	1	0
0	0	0	0	0	ADCAnRQ[2:0]			0	0	0	0	0	ADCAnST[2:0]		
R	R	R	R	R	R	R	R	R	R	R	R	R	R	R	R

Table 23-19 ADCAnSTR2 Register Contents

Bit Position	Bit Name	Function
10 to 8	ADCAnRQ [2:0]	Indicates whether the A/D conversion request for CGi is pending: 0: A/D conversion request for CGi is not pending 1: A/D conversion request for CGi is pending
2 to 0	ADCAnST [2:0]	Indicates whether A/D conversion of CGi is currently performed: 0: A/D conversion is not currently performed (including a halt due to an A/D conversion of a higher-priority CG) 1: A/D conversion is currently performed This bit is cleared when the A/D converter is disabled (ADCAnCTL0.ADCAnCE = 0).

(4) ADCAnSTC2 – A/D Converter Status Flag Clear Register 2

This register is used to clear the overwrite and result check status flags of ADCAnLCR and ADCAnDBiCR.

Access This register can be written in 8-bit units.
It is always read as 00_H.

Address <ADCAn_base1> + 38_H

Initial value 00_H

This register is initialized by any reset.

7	6	5	4	3	2	1	0
ADCAn LERC1	ADCAn LERC0	ADCAn DB2ERC1	ADCAn DB2ERC0	ADCAn DB1ERC1	ADCAn DB1ERC0	ADCAn DB0ERC1	ADCAn DB0ERC0
W	W	W	W	W	W	W	W

Table 23-20 ADCAnSTC2 Register Contents

Bit Position	Bit Name	Function
7	ADCAn LERC1	Clears the overwrite flag (ADCAnLCR.ADCAnLER1 bit): 0: No effect (writing 0 to this bit does not affect the flag). 1: Clears ADCAnLCR.ADCAnLER1
6	ADCAn LERC0	Clears the result check error flag (ADCAnLCR.ADCAnLER0 bit): 0: No effect (writing 0 to this bit does not affect the flag). 1: Clears ADCAnLCR.ADCAnLER0
5, 3, 1	ADCAn DBiERC1	Clears the overwrite flag (ADCAnDBiCR.ADCAnDBiER1 bit): 0: No effect (writing 0 to this bit does not affect the flag). 1: Clears ADCAnDBiCR.ADCAnDBiER1
4, 2, 0	ADCAn DBiERC0	Clears the result check error flag (ADCAnDBiCR.ADCAnDBiER0 bit): 0: No effect (writing 0 to this bit does not affect the flag). 1: Clears ADCAnDBiCR.ADCAnDBiER0

23.4.4 Software Trigger Registers

(1) ADCAnTRGi – A/D Converter Software Trigger Register i

This register is the trigger register to start the A/D conversion of CGi.

Access This register can be written in 8-bit units.
It is always read as 00H.

Address <ADCAn_base1> + A4H + i × 4H

Initial value 00H

This register is initialized by any reset.

7	6	5	4	3	2	1	0
0	0	0	0	0	0	0	ADCAn STTi
W	W	W	W	W	W	W	W

Table 23-21 ADCAnTRGi Register Contents

Bit Position	Bit Name	Function
0	ADCAnSTTi	Starts the A/D conversion of CGi: 0: No effect (writing 0 to this bit does not start A/D conversion on CGi). 1: Starts A/D conversion of CGi

For details, refer to Section 23.3.5, Starting A/D Conversion (Start Triggers).

23.4.5 A/D Conversion Result Registers

(1) ADCAnLCR – A/D Converter Latest Conversion Result Register

This register stores the result and the status of the latest A/D conversion. It allows the latest A/D conversion results to be read.

Access This register can be read in 32-bit units.

- The upper 16 bits store the A/D conversion result status.
- The lower 16 bits store the A/D conversion result.

Address <ADCAn_base1> + A0_H

Initial value 0300 0000_H

This register is initialized by any reset.

31	30	29	28	27	26	25	24	23	22	21	20	19	18	17	16
0	0	0	0	0	0	ADCAn LCG[1:0]	ADCAn LER1	ADCAn LER0	ADCAn LUR	ADCAnLCN[4:0]					
R	R	R	R	R	R	R	R	R	R	R	R	R	R	R	R
15	14	13	12	11	10	9	8	7	6	5	4	3	2	1	0
ADCAnLCR[15:00]															
R	R	R	R	R	R	R	R	R	R	R	R	R	R	R	R

Table 23-22 ADCAnLCR Register Contents (1/2)

Bit Position	Bit Name	Function															
25, 24	ADCAn LCG[1:0]	Indicates the CG to which the conversion result in ADCAnLCR[15:00] belongs. <table border="1" style="margin-left: 20px;"> <thead> <tr> <th>ADCAn LCG1</th> <th>ADCAn LCG0</th> <th>Channel Group</th> </tr> </thead> <tbody> <tr> <td>0</td> <td>0</td> <td>CG0</td> </tr> <tr> <td>0</td> <td>1</td> <td>CG1</td> </tr> <tr> <td>1</td> <td>0</td> <td>CG2</td> </tr> <tr> <td>1</td> <td>1</td> <td>None</td> </tr> </tbody> </table>	ADCAn LCG1	ADCAn LCG0	Channel Group	0	0	CG0	0	1	CG1	1	0	CG2	1	1	None
ADCAn LCG1	ADCAn LCG0	Channel Group															
0	0	CG0															
0	1	CG1															
1	0	CG2															
1	1	None															
23	ADCAn LER1	Indicates the overwrite error status: 0: The conversion result has not been overwritten 1: The conversion result has been overwritten This error flag is cleared when ADCAnSTC2.ADCAnLERC1 is set to 1.															
22	ADCAn LER0	Indicates the upper/lower limit comparison result of the A/D conversion result: 0: The conversion result is within the specified range 1: The conversion result is out of the specified range This error flag is cleared when ADCAnSTC2.ADCAnLERC0 is set to 1.															
21	ADCAn LUR	Indicates the update status of the A/D conversion result: 0: The A/D conversion result has been read from ADCAnLCR (the result has not been updated) 1: The A/D conversion result has not been read from ADCAnLCR (the result has been updated) This bit is cleared after the conversion result is read.															

Table 23-22 ADCAnLCR Register Contents (2/2)

Bit Position	Bit Name	Function																				
20 to 16	ADCAn LCN[4:0]	Indicates the number of the channel to which the result in ADCAnLCR[15:00] belongs: $00001 \times m = CHm$																				
15 to 0	ADCAn LCR[15:00]	Indicates the result of the A/D conversion. The resolution and alignment depend on ADCAnCTL1.ADCAnCTYP and ADCAnCTL1.ADCAnCRAC as follows: <table border="1" style="margin-left: 20px;"> <thead> <tr> <th>ADCAn CTL1. ADCAn CTYP</th> <th>ADCAn CTL1. ADCAn CRAC</th> <th>Resolution and Alignment</th> <th>Bit Position of Conversion Result Value</th> </tr> </thead> <tbody> <tr> <td>0</td> <td>0</td> <td>12-bit resolution, right-aligned</td> <td>ADCAnLCR[11:00]</td> </tr> <tr> <td>0</td> <td>1</td> <td>12-bit resolution, left-aligned</td> <td>ADCAnLCR[15:04]</td> </tr> <tr> <td>1</td> <td>0</td> <td>10-bit resolution, right-aligned</td> <td>ADCAnLCR[09:00]</td> </tr> <tr> <td>1</td> <td>1</td> <td>10-bit resolution, left-aligned</td> <td>ADCAnLCR[15:06]</td> </tr> </tbody> </table>	ADCAn CTL1. ADCAn CTYP	ADCAn CTL1. ADCAn CRAC	Resolution and Alignment	Bit Position of Conversion Result Value	0	0	12-bit resolution, right-aligned	ADCAnLCR[11:00]	0	1	12-bit resolution, left-aligned	ADCAnLCR[15:04]	1	0	10-bit resolution, right-aligned	ADCAnLCR[09:00]	1	1	10-bit resolution, left-aligned	ADCAnLCR[15:06]
ADCAn CTL1. ADCAn CTYP	ADCAn CTL1. ADCAn CRAC	Resolution and Alignment	Bit Position of Conversion Result Value																			
0	0	12-bit resolution, right-aligned	ADCAnLCR[11:00]																			
0	1	12-bit resolution, left-aligned	ADCAnLCR[15:04]																			
1	0	10-bit resolution, right-aligned	ADCAnLCR[09:00]																			
1	1	10-bit resolution, left-aligned	ADCAnLCR[15:06]																			

Note The result of the diagnostic A/D conversion of an internal reference voltage is stored in ADCAnDGCR, not in ADCAnLCR, ADCAnCmCR (refer to Section 23.4.5 (5), ADCAnDGCR – A/D Converter Diagnosis Conversion Result Register).

(2) ADCAnCmCR – A/D Converter Conversion Result Register for Channel m

This register stores the result and the status of the latest A/D conversion of channel m.

It allows you to read the A/D conversion result of the specified channel (m).

Access This register can be read in 32-bit units.

- The upper 16 bits store the A/D conversion result status.
- The lower 16 bits store the A/D conversion result.

Address <ADCAn_base1> + 3C_H + m × 4_H

Initial value 0300 0000_H + m × 0001 0000_H

This register is initialized by any reset.

31	30	29	28	27	26	25	24	23	22	21	20	19	18	17	16
0	0	0	0	0	0	ADCAn CmCG[1:0]	ADCAn CmER1	ADCAn CmER0	ADCAn CmUR	ADCAnCmCN[4:0]					
R	R	R	R	R	R	R	R	R	R	R	R	R	R	R	R
15	14	13	12	11	10	9	8	7	6	5	4	3	2	1	0
ADCAnCmCR[15:00]															
R	R	R	R	R	R	R	R	R	R	R	R	R	R	R	R

Note 1. The functions of the individual bits are identical to those of the corresponding bits in ADCAnLCR, except that this register indicates the latest A/D conversion result of a specified channel rather than the latest results of all the channels (refer to Table 23-22, ADCAnLCR Register Contents).

Note 2. After reset, ADCAnCmCG[1:0] are set to 11_B.

Note 3. When ADCAnCTL1.ADCAnRCL = 0, the A/D conversion result in ADCAnCmCR[15:00] is kept until it is overwritten by the next A/D conversion result.

When ADCAnCTL1.ADCAnRCL = 1, the A/D conversion result in ADCAnCmCR[15:00] is cleared after being read.

Table 23-23 ADCAnCmCR Register Contents

Bit Position	Bit Name	Function																				
25, 24	ADCAnCmCG[1:0]	<p>Indicates the CG to which the conversion result in ADCAnCmCR [15:00] belongs.</p> <table border="1"> <thead> <tr> <th>ADCAnCmCG1</th> <th>ADCAnCmCG0</th> <th>Channel Group</th> </tr> </thead> <tbody> <tr> <td>0</td> <td>0</td> <td>CG0</td> </tr> <tr> <td>0</td> <td>1</td> <td>CG1</td> </tr> <tr> <td>1</td> <td>0</td> <td>CG2</td> </tr> <tr> <td>1</td> <td>1</td> <td>None</td> </tr> </tbody> </table>	ADCAnCmCG1	ADCAnCmCG0	Channel Group	0	0	CG0	0	1	CG1	1	0	CG2	1	1	None					
ADCAnCmCG1	ADCAnCmCG0	Channel Group																				
0	0	CG0																				
0	1	CG1																				
1	0	CG2																				
1	1	None																				
23	ADCAnCmER1	<p>Indicates the overwrite error status:</p> <p>0: The conversion result has not been overwritten 1: The conversion result has been overwritten</p> <p>This error flag reflects the value of ADCAnSTR1.ADCAnOWEm and is cleared when ADCAnSTC1.ADCAnQWECm is set to 1.</p>																				
22	ADCAnCmER0	<p>Indicates the upper/lower limit comparison result of the A/D conversion result:</p> <p>0: The conversion result is within the specified range 1: The conversion result is out of the specified range</p> <p>This error flag reflects the value of ADCAnSTR0.ADCAnRCEm and is cleared when ADCAnSTC0.ADCAnRCECm is set to 1.</p>																				
21	ADCAnCmUR	<p>Indicates the update status of the A/D conversion result:</p> <p>0: The A/D conversion result has been read from ADCAnCmCR (the result has not been updated) 1: The A/D conversion result has not been read from ADCAnCmCR (the result has been updated)</p> <p>This bit is cleared after the conversion result is read.</p>																				
20 to 16	ADCAnCmCN[4:0]	<p>Indicates the number of the channel to which the conversion result in ADCAnCmCR [15:00] belongs:</p> <p>$00001 \times m = CHm$</p>																				
15 to 0	ADCAnCmCR [15:00]	<p>Indicates the result of the A/D conversion. The resolution and alignment depend on ADCAnCTL1.ADCAnCTYP and ADCAnCTL1.ADCAnCRAC as follows:</p> <table border="1"> <thead> <tr> <th>ADCAnCTL1.ADCAnCTYP</th> <th>ADCAnCTL1.ADCAnCRAC</th> <th>Resolution and Alignment</th> <th>Bit Position of A/D Conversion Result Value</th> </tr> </thead> <tbody> <tr> <td>0</td> <td>0</td> <td>12-bit resolution, right-aligned</td> <td>ADCAnCmCR[11:00]</td> </tr> <tr> <td>0</td> <td>1</td> <td>12-bit resolution, left-aligned</td> <td>ADCAnCmCR[15:04]</td> </tr> <tr> <td>1</td> <td>0</td> <td>10-bit resolution, right-aligned</td> <td>ADCAnCmCR[09:00]</td> </tr> <tr> <td>1</td> <td>1</td> <td>10-bit resolution, left-aligned</td> <td>ADCAnCmCR[15:06]</td> </tr> </tbody> </table>	ADCAnCTL1.ADCAnCTYP	ADCAnCTL1.ADCAnCRAC	Resolution and Alignment	Bit Position of A/D Conversion Result Value	0	0	12-bit resolution, right-aligned	ADCAnCmCR[11:00]	0	1	12-bit resolution, left-aligned	ADCAnCmCR[15:04]	1	0	10-bit resolution, right-aligned	ADCAnCmCR[09:00]	1	1	10-bit resolution, left-aligned	ADCAnCmCR[15:06]
ADCAnCTL1.ADCAnCTYP	ADCAnCTL1.ADCAnCRAC	Resolution and Alignment	Bit Position of A/D Conversion Result Value																			
0	0	12-bit resolution, right-aligned	ADCAnCmCR[11:00]																			
0	1	12-bit resolution, left-aligned	ADCAnCmCR[15:04]																			
1	0	10-bit resolution, right-aligned	ADCAnCmCR[09:00]																			
1	1	10-bit resolution, left-aligned	ADCAnCmCR[15:06]																			

Note The result of the diagnostic A/D conversion of an internal reference voltage is stored in ADCAnDGCR, not in ADCAnLCR or ADCAnCmCR (refer to Section 23.4.5 (5), ADCAnDGCR – A/D Converter Diagnosis Conversion Result Register).

(3) ADCAnDBiCR – CGi DMA buffer register

This register holds the result and the status of the latest A/D conversion of CGi. It allows the A/D conversion results of all the channels of CGi to be read.

Access This register can be read in 32-bit units.

- The upper 16 bits store the A/D conversion result status.
- The lower 16 bits store the A/D conversion result.

Address <ADCAn_base1> + C4_H + i × 4_H

Initial value 0000 0000_H + i × 0100 0000_H

This register is initialized by any reset.

31	30	29	28	27	26	25	24	23	22	21	20	19	18	17	16
0	0	0	0	0	0	ADCAn DBiCG[1:0]		ADCAn DBiER1	ADCAn DBiER0	ADCAn DBiUR	ADCAnDBiCN[4:0]				
R	R	R	R	R	R	R	R	R	R	R	R	R	R	R	R
15	14	13	12	11	10	9	8	7	6	5	4	3	2	1	0
ADCAnDBiCR[15:00]															
R	R	R	R	R	R	R	R	R	R	R	R	R	R	R	R

Note The functions of the individual bits are identical to those of the corresponding bits in ADCAnLCR, except that this register indicates the latest A/D conversion result of CGi rather than the latest results of all the CGs (refer to Table 23-22, ADCAnLCR Register Contents).

Table 23-24 ADCAnDBiCR Register Contents (1/2)

Bit Position	Bit Name	Function																		
25, 24	ADCAn DBiCG[1:0]	Indicates the CG to which the conversion result in ADCAnDBiCR [15:00] belongs. <table border="1" style="margin: 10px auto;"> <thead> <tr> <th>ADCAn DBiCG</th><th>ADCAn DBiCG</th><th>Channel Group</th></tr> </thead> <tbody> <tr> <td>1</td><td>0</td><td>CG0</td></tr> <tr> <td>0</td><td>0</td><td>CG0</td></tr> <tr> <td>0</td><td>1</td><td>CG1</td></tr> <tr> <td>1</td><td>0</td><td>CG2</td></tr> <tr> <td>1</td><td>1</td><td>None</td></tr> </tbody> </table> These bit settings are fixed since the conversion results and status of the same CG are always stored.	ADCAn DBiCG	ADCAn DBiCG	Channel Group	1	0	CG0	0	0	CG0	0	1	CG1	1	0	CG2	1	1	None
ADCAn DBiCG	ADCAn DBiCG	Channel Group																		
1	0	CG0																		
0	0	CG0																		
0	1	CG1																		
1	0	CG2																		
1	1	None																		
23	ADCAn DBiER1	Indicates the overwrite error status: 0: The conversion result has not been overwritten 1: The conversion result has been overwritten This error flag is cleared when ADCAnSTC2.ADCAnDBiERC1 is set to 1.																		
22	ADCAn DBiER0	Indicates the upper/lower limit comparison result of the A/D conversion result: 0: The conversion result is within the specified range 1: The conversion result is out of the specified range This error flag is cleared when ADCAnSTC2.ADCAnDBiERC0 is set to 1.																		

Table 23-24 ADCAnDBiCR Register Contents (2/2)

Bit Position	Bit Name	Function																				
21	ADCAnDBiUR	Indicates the update status of the A/D conversion result: 0: The A/D conversion result has been read from ADCAnDBiCR (the result has not been updated) 1: The A/D conversion result has not been read from ADCAnDBiCR (the result has been updated) This bit is cleared after the conversion result is read.																				
20 to 16	ADCAnDBiCN[4:0]	Indicates the number of the channel to which the conversion result in ADCAnDBiCR [15:00] belongs: 00001 × m = CHm																				
15 to 0	ADCAnDBiCR [15:00]	Indicates the result of the A/D conversion. The resolution and alignment depend on ADCAnCTL1.ADCAnCTYP and ADCAnCTL1.ADCAnCRAC as follows: <table border="1" style="margin-left: 20px;"> <thead> <tr> <th>ADCAnCTL1.ADCAnCTYP</th> <th>ADCAnCTL1.ADCAnCRAC</th> <th>Resolution and Alignment</th> <th>Bit Position of A/D Conversion Result Value</th> </tr> </thead> <tbody> <tr> <td>0</td> <td>0</td> <td>12-bit resolution, right-aligned</td> <td>ADCAnDBiCR[11:00]</td> </tr> <tr> <td>0</td> <td>1</td> <td>12-bit resolution, left-aligned</td> <td>ADCAnDBiCR[15:04]</td> </tr> <tr> <td>1</td> <td>0</td> <td>10-bit resolution, right-aligned</td> <td>ADCAnDBiCR[09:00]</td> </tr> <tr> <td>1</td> <td>1</td> <td>10-bit resolution, left-aligned</td> <td>ADCAnDBiCR[15:06]</td> </tr> </tbody> </table>	ADCAnCTL1.ADCAnCTYP	ADCAnCTL1.ADCAnCRAC	Resolution and Alignment	Bit Position of A/D Conversion Result Value	0	0	12-bit resolution, right-aligned	ADCAnDBiCR[11:00]	0	1	12-bit resolution, left-aligned	ADCAnDBiCR[15:04]	1	0	10-bit resolution, right-aligned	ADCAnDBiCR[09:00]	1	1	10-bit resolution, left-aligned	ADCAnDBiCR[15:06]
ADCAnCTL1.ADCAnCTYP	ADCAnCTL1.ADCAnCRAC	Resolution and Alignment	Bit Position of A/D Conversion Result Value																			
0	0	12-bit resolution, right-aligned	ADCAnDBiCR[11:00]																			
0	1	12-bit resolution, left-aligned	ADCAnDBiCR[15:04]																			
1	0	10-bit resolution, right-aligned	ADCAnDBiCR[09:00]																			
1	1	10-bit resolution, left-aligned	ADCAnDBiCR[15:06]																			

Note 1. ADCAnDBiCR[15:00] is

- retained until the next A/D conversion result is overwritten when ADCAnCTL1.ADCAnRCL bit = 0,
- cleared after reading ADCAnDBiCR register when ADCAnCTL1.ADCAnRCL bit = 1.

Note 2. The result of the diagnostic A/D conversion of an internal reference voltage is stored in ADCAnDGCR, not in ADCAnLCR, ADCAnCmCR (refer to Section 23.4.5 (5), ADCAnDGCR – A/D Converter Diagnosis Conversion Result Register).

(4) ADCAnDBiCRL – A/D Converter CGi DMA Buffer Register (Conversion Result)

This register holds the result of the latest A/D conversion of CGi. It allows the A/D conversion results of all the channels of CGi to be read. This register reflects the settings of ADCAnDBiCR[15:00].

Access This register is read-only and can be read in 16-bit units.

Address <ADCAn_base1> + D0_H + i × 4_H

Initial value 0000_H

This register is initialized by any reset.

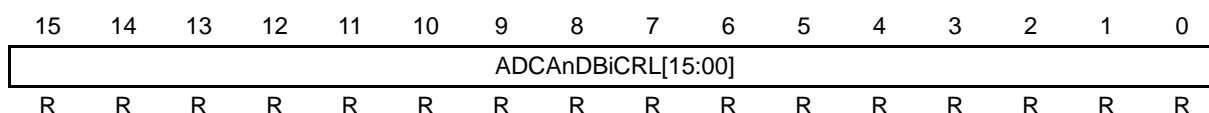

Table 23-25 ADCAnDBiCRL Register Contents

Bit Position	Bit Name	Function																				
15 to 0	ADCAnDBiCRL[15:00]	<p>Indicates the result of the A/D conversion. The resolution and alignment depend on ADCAnCTL1.ADCAnCTYP and ADCAnCTL1.ADCAnCRAC as follows:</p> <table border="1" style="width: 100%; border-collapse: collapse; margin-top: 10px;"> <thead> <tr> <th style="width: 10%;">ADCAnCTL1.ADCAnCTYP</th><th style="width: 10%;">ADCAnCTL1.ADCAnCRAC</th><th style="width: 40%;">Resolution and Alignment</th><th style="width: 40%;">Bit Position of A/D Conversion Result Value</th></tr> </thead> <tbody> <tr> <td style="text-align: center;">0</td><td style="text-align: center;">0</td><td>12-bit resolution and right-aligned</td><td>[11:00] in ADCAnDBiCR[15:00]</td></tr> <tr> <td style="text-align: center;">0</td><td style="text-align: center;">1</td><td>12-bit resolution and left-aligned</td><td>[15:04] in ADCAnDBiCR[15:00]</td></tr> <tr> <td style="text-align: center;">1</td><td style="text-align: center;">0</td><td>10-bit resolution and right-aligned</td><td>[09:00] in ADCAnDBiCR[15:00]</td></tr> <tr> <td style="text-align: center;">1</td><td style="text-align: center;">1</td><td>10-bit resolution and left-aligned</td><td>[15:06] in ADCAnDBiCR[15:00]</td></tr> </tbody> </table>	ADCAnCTL1.ADCAnCTYP	ADCAnCTL1.ADCAnCRAC	Resolution and Alignment	Bit Position of A/D Conversion Result Value	0	0	12-bit resolution and right-aligned	[11:00] in ADCAnDBiCR[15:00]	0	1	12-bit resolution and left-aligned	[15:04] in ADCAnDBiCR[15:00]	1	0	10-bit resolution and right-aligned	[09:00] in ADCAnDBiCR[15:00]	1	1	10-bit resolution and left-aligned	[15:06] in ADCAnDBiCR[15:00]
ADCAnCTL1.ADCAnCTYP	ADCAnCTL1.ADCAnCRAC	Resolution and Alignment	Bit Position of A/D Conversion Result Value																			
0	0	12-bit resolution and right-aligned	[11:00] in ADCAnDBiCR[15:00]																			
0	1	12-bit resolution and left-aligned	[15:04] in ADCAnDBiCR[15:00]																			
1	0	10-bit resolution and right-aligned	[09:00] in ADCAnDBiCR[15:00]																			
1	1	10-bit resolution and left-aligned	[15:06] in ADCAnDBiCR[15:00]																			

Note 1. The value of this register is:

- Retained until the A/D conversion result is overwritten by the next A/D conversion result when ADCAnCTL1.ADCAnRCL = 0.
- Cleared after the A/D conversion results in ADCAnDBiCR and ADCAnDBiCRL is read when ADCAnCTL1.ADCAnRCL = 1.

Note 2. The result of the diagnostic A/D conversion of an internal reference voltage is stored in ADCAnDGCR, not in ADCAnLCR, ADCAnCmCR (refer to Section 23.4.5 (5), ADCAnDGCR – A/D Converter Diagnosis Conversion Result Register).

(5) ADCAnDGCR – A/D Converter Diagnosis Conversion Result Register

This register stores the A/D conversion result of the reference voltage signal ADDIAGOUT (when ADCAnCG0.ADCAnDIAG = 1).

The diagnosis A/D conversion is started after the A/D conversion of the last channel of CG0 is completed.

Access This register can be read in 16-bit units.

Address <ADCAn_base1> + 9C_H

Initial value 0000_H

This register is initialized by any reset.

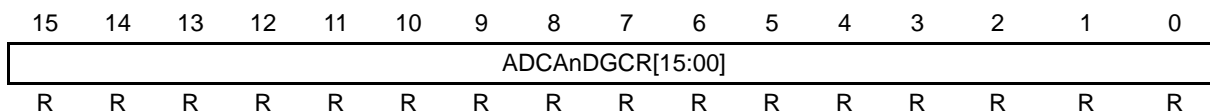

Table 23-26 ADCAnDGCR Register Contents

Bit Position	Bit Name	Function
15 to 0	ADCAnDGCR[15:00]	Indicates the result of the diagnostic A/D conversion. The resolution and alignment depend on ADCAnCTL1.ADCAnCTYP and ADCAnCTL1.ADCAnCRAC, as is the case with the normal A/D conversion result registers.

23.4.6 A/D Conversion Result Upper/Lower Limit Comparison Registers

(1) ADCAnCTL2 – A/D Conversion Result Check Register

This register enables or disables the upper/lower limit comparison function for the conversion result for every channel.

For details, refer to Section 23.3.10, Result Check Functions.

Access This register can be read/written in 32-bit units.
It can only be written when the A/D converter is disabled (ADCAnCTL0.ADCAnCE = 0).

Address <ADCAn_base1> + 18_H

Initial value 0000 0000_H

This register is initialized by any reset.

31	30	29	28	27	26	25	24	23	22	21	20	19	18	17	16
0	0	0	0	0	0	0	0	ADCAnRCK[23:16]							
R	R	R	R	R	R	R	R	R/W	R/W	R/W	R/W	R/W	R/W	R/W	R/W
15	14	13	12	11	10	9	8	7	6	5	4	3	2	1	0
ADCAnRCK[15:00]															
R/W	R/W	R/W	R/W	R/W	R/W	R/W	R/W	R/W	R/W	R/W	R/W	R/W	R/W	R/W	R/W

Table 23-27 ADCAnCTL2 Register Contents

Bit Position	Bit Name	Function
23 to 00	ADCAnRCK[23:00]	<p>Enables or disables the upper/lower limit comparison for the result of CH_m</p> <p>0: Does not perform the upper/lower limit comparison for the A/D conversion result of CH_m</p> <p>1: Performs the upper/lower limit comparison for the A/D conversion result of CH_m</p> <p>Note: The bits corresponding to the channels that are not implemented in this product should be cleared to 0 (for the applicable bits, refer to the Number of analog input pins fields in the table in Section 23.1, ADCA Features).</p>

Note These settings are valid for the A/D conversions of every CG.

(2) ADCAnUL – A/D Converter Result Upper/Lower Limit Comparison (Upper Limit)

This register specifies the upper limit of the A/D conversion result.

For details, refer to Section 23.3.10, Result Check Functions.

Access This register can be read/written in 16-bit units.
It can only be written when the A/D converter is disabled (ADCAnCTL0.ADCAnCE = 0).

Address <ADCAn_base1> + 1C_H

Initial value 0000_H

This register is initialized by any reset

15	14	13	12	11	10	9	8	7	6	5	4	3	2	1	0
ADCAnUL[11:00]												0	0	0	0
R/W	R/W	R/W	R/W	R/W	R/W	R/W	R/W	R/W	R/W	R/W	R/W	R	R	R	R

Table 23-28 ADCAnUL Register Contents

Bit Position	Bit Name	Function
15 to 4	ADCAnUL [11:00]	Specifies the upper limit of the A/D conversion result. In 10-bit mode, set the limit in ADCAnUL[11:02]. (Set ADCAnUL[01:00] to 11B.)

(3) ADCAnLL – A/D Converter Result Upper/Lower Limit Comparison (Lower Limit)

This register specifies the lower limit of the A/D conversion result.

For details, refer to Section 23.3.10, Result Check Functions.

Access This register can be read/written in 16-bit units.
It can only be written when the A/D converter is disabled (ADCAnCTL0.ADCAnCE = 0).

Address <ADCAn_base1> + 20_H

Initial value 0000_H

This register is initialized by any reset.

15	14	13	12	11	10	9	8	7	6	5	4	3	2	1	0
ADCAnLL[11:00]												0	0	0	0
R/W	R/W	R/W	R/W	R/W	R/W	R/W	R/W	R/W	R/W	R/W	R/W	R	R	R	R

Table 23-29 ADCAnLL Register Contents

Bit Position	Bit Name	Function
15 to 4	ADCAnLL [11:00]	Specifies the lower limit of the A/D conversion result. In 10-bit mode, set the limit in ADCAnLL[11:02]. (Set 00 _B to ADCAnLL[01:00]).

(4) ADCAnSTR0 – A/D Converter Result Upper/Lower Limit Comparison Error Flag

This register indicates the error status of the latest A/D conversion result check for the channels set in ADCAnCTL2. This allows to check which A/D conversion results are outside the specified range.

For details, refer to Section 23.3.10, Result Check Functions.

Access This register can be read in 32-bit units.

Address <ADCAn_base1> + 24_H

Initial value 0000 0000_H

This register is initialized by any reset.

31	30	29	28	27	26	25	24	23	22	21	20	19	18	17	16
0	0	0	0	0	0	0	0	ADCAnRCE[23:16]							
R	R	R	R	R	R	R	R	R	R	R	R	R	R	R	R
15	14	13	12	11	10	9	8	7	6	5	4	3	2	1	0
ADCAnRCE[15:00]															
R	R	R	R	R	R	R	R	R	R	R	R	R	R	R	R

Table 23-30 ADCAnSTR0 Register Contents

Bit Position	Bit Name	Function
23 to 0	ADCAnRCE[23:00]	Indicates whether the A/D conversion result is within the specified range: 0: The conversion result is within the specified range 1: One or more conversion results are out of the specified range This error flag is cleared when ADCAnSTC0.ADCAnRCECm is set to 1. Note: The bits corresponding to the channels that are not implemented in this product should be cleared to 0 (for the applicable bits, refer to the Number of analog input pins fields in the table in Section 23.1, ADCA Features).

Note The value of ADCAnSTR0.ADCAnRCEm is reflected in the following A/D conversion result error flag.

- The error flag in the A/D converter conversion result register for channel m (ADCAnCmCR.ADCAnCmER0)

(5) ADCAnSTC0 – ADCAnSTR0 Flag Clear Register

This register is the clear control register of ADCAnSTR0.

Access This register can be written in 32-bit units.
It is always read as 0000 0000_H.

Address <ADCAn_base1> + 30_H

Initial value 0000 0000_H

This register is initialized by any reset.

31	30	29	28	27	26	25	24	23	22	21	20	19	18	17	16
0	0	0	0	0	0	0	0	ADCAnRCEC[23:16]							
W	W	W	W	W	W	W	W	W	W	W	W	W	W	W	W
15	14	13	12	11	10	9	8	7	6	5	4	3	2	1	0
ADCAnRCEC[15:00]															
W	W	W	W	W	W	W	W	W	W	W	W	W	W	W	W

Table 23-31 ADCAnSTC0 Register Contents

Bit Position	Bit Name	Function
23 to 0	ADCAnRCEC [23:00]	Clears the A/D converter result upper/lower limit comparison error flag (ADCAnSTR0.ADCAnRCEm bit). 0: No function 1: Clears ADCAnSTR0.ADCAnRCEm Note: The bits corresponding to the channels that are not implemented in this product should be cleared to 0 (for the applicable bits, refer to the Number of analog input pins fields in the table in Section 23.1, ADCA Features).

23.4.7 Diagnosis Function Control Registers

(1) ADCAnDGCTL0 – Self-Diagnosis Function Control Register 0

This register specifies the reference voltages applied for diagnosing the operation of the A/D conversion circuit.

Access This register can be read/written in 16-bit units.

Address <ADCAn_base1> + DC_H

Initial value 0000_H

This register is initialized by any reset.

15	14	13	12	11	10	9	8	7	6	5	4	3	2	1	0
0	0	0	0	0	0	0	0	0	0	0	0	0	ADCAnPSEL[2:0]		
R	R	R	R	R	R	R	R	R	R	R	R	R	R/W	R/W	R/W

Table 23-32 ADCAnDGCTL0 Register Contents

Bit Position	Bit Name	Function																																																															
2 to 0	ADCAn PSEL[2:0]	Specifies the reference voltages.																																																															
		<table border="1"> <thead> <tr> <th>ADCAn PSEL2</th><th>ADCAn PSEL1</th><th>ADCAn PSEL0</th><th>ADDIAGOUT Signal</th><th>DIAGOUT2 Signal</th><th>DIAGOUT1 Signal</th><th>DIAGOUT0 Signal</th></tr> </thead> <tbody> <tr> <td>0</td><td>0</td><td>0</td><td>AV_{SS}</td><td>2/3 AV_{DD}</td><td>1/2 AV_{DD}</td><td>1/3 AV_{DD}</td></tr> <tr> <td>0</td><td>0</td><td>1</td><td>1/3 AV_{DD}</td><td>1/2 AV_{DD}</td><td>1/3 AV_{DD}</td><td>2/3 AV_{DD}</td></tr> <tr> <td>0</td><td>1</td><td>0</td><td>1/2 AV_{DD}</td><td>1/3 AV_{DD}</td><td>2/3 AV_{DD}</td><td>1/2 AV_{DD}</td></tr> <tr> <td>0</td><td>1</td><td>1</td><td>2/3 AV_{DD}</td><td>Hi-Z</td><td>Hi-Z</td><td>Hi-Z</td></tr> <tr> <td>1</td><td>0</td><td>0</td><td>AV_{DD}</td><td>2/3 AV_{DD}</td><td>1/2 AV_{DD}</td><td>1/3 AV_{DD}</td></tr> <tr> <td>1</td><td>0</td><td>1</td><td>AV_{DD}</td><td>1/2 AV_{DD}</td><td>1/3 AV_{DD}</td><td>2/3 AV_{DD}</td></tr> <tr> <td>1</td><td>1</td><td>0</td><td>AV_{DD}</td><td>1/3 AV_{DD}</td><td>2/3 AV_{DD}</td><td>1/2 AV_{DD}</td></tr> <tr> <td>1</td><td>1</td><td>1</td><td>AV_{DD}</td><td>Hi-Z</td><td>Hi-Z</td><td>Hi-Z</td></tr> </tbody> </table>	ADCAn PSEL2	ADCAn PSEL1	ADCAn PSEL0	ADDIAGOUT Signal	DIAGOUT2 Signal	DIAGOUT1 Signal	DIAGOUT0 Signal	0	0	0	AV _{SS}	2/3 AV _{DD}	1/2 AV _{DD}	1/3 AV _{DD}	0	0	1	1/3 AV _{DD}	1/2 AV _{DD}	1/3 AV _{DD}	2/3 AV _{DD}	0	1	0	1/2 AV _{DD}	1/3 AV _{DD}	2/3 AV _{DD}	1/2 AV _{DD}	0	1	1	2/3 AV _{DD}	Hi-Z	Hi-Z	Hi-Z	1	0	0	AV _{DD}	2/3 AV _{DD}	1/2 AV _{DD}	1/3 AV _{DD}	1	0	1	AV _{DD}	1/2 AV _{DD}	1/3 AV _{DD}	2/3 AV _{DD}	1	1	0	AV _{DD}	1/3 AV _{DD}	2/3 AV _{DD}	1/2 AV _{DD}	1	1	1	AV _{DD}	Hi-Z	Hi-Z	Hi-Z
ADCAn PSEL2	ADCAn PSEL1	ADCAn PSEL0	ADDIAGOUT Signal	DIAGOUT2 Signal	DIAGOUT1 Signal	DIAGOUT0 Signal																																																											
0	0	0	AV _{SS}	2/3 AV _{DD}	1/2 AV _{DD}	1/3 AV _{DD}																																																											
0	0	1	1/3 AV _{DD}	1/2 AV _{DD}	1/3 AV _{DD}	2/3 AV _{DD}																																																											
0	1	0	1/2 AV _{DD}	1/3 AV _{DD}	2/3 AV _{DD}	1/2 AV _{DD}																																																											
0	1	1	2/3 AV _{DD}	Hi-Z	Hi-Z	Hi-Z																																																											
1	0	0	AV _{DD}	2/3 AV _{DD}	1/2 AV _{DD}	1/3 AV _{DD}																																																											
1	0	1	AV _{DD}	1/2 AV _{DD}	1/3 AV _{DD}	2/3 AV _{DD}																																																											
1	1	0	AV _{DD}	1/3 AV _{DD}	2/3 AV _{DD}	1/2 AV _{DD}																																																											
1	1	1	AV _{DD}	Hi-Z	Hi-Z	Hi-Z																																																											
		The A/D conversion result is undefined when the conversion is performed with Hi-Z selected.																																																															

For details, refer to Section 23.3.11 (1), Diagnosis of A/D Conversion Circuit.

(2) ADCAnDGCTL1 – Self-Diagnosis Function Control Register 1

This register specifies to which channel an internal reference voltage (instead of the analog input voltage ADCAnIm) is applied.

This register is writable only when ADCAnCTL0.ADCAnCE = 0.

Access This register can be read/written in 32-bit units.

Address <ADCAn_base0> + 11C_H

Initial value 0000 0000_H

This register is initialized by any reset.

31	30	29	28	27	26	25	24	23	22	21	20	19	18	17	16
0	0	0	0	0	0	0	0	ADCAnCDG[23:16]							
R	R	R	R	R	R	R	R	R/W	R/W	R/W	R/W	R/W	R/W	R/W	R/W
15	14	13	12	11	10	9	8	7	6	5	4	3	2	1	0
ADCAnCDG[15:00]															
R/W	R/W	R/W	R/W	R/W	R/W	R/W	R/W	R/W	R/W	R/W	R/W	R/W	R/W	R/W	R/W

Table 23-33 ADCAnDGCTL1 Register Contents

Bit Position	Bit Name	Function
23 to 0	ADCAnCDG[23:00]	Specifies the input voltage 0: Uses the analog input voltage ADCAnIm 1: Uses the following reference voltages: DIAGOUT0 for m = 18, 15, 12, 9, 6, and 3 DIAGOUT1 for m = 16, 13, 10, 7, 4, and 1 DIAGOUT2 for m = 17, 14, 11, 8, 5, and 2 Note: The bits corresponding to the channels that are not implemented in this product should be cleared to 0 (for the applicable bits, refer to the Number of analog input pins fields in the table in Section 23.1, ADCA Features).

(3) ADCAnPDCTL0 – Internal Pull-Down Resistance Control Register 0

This register specifies the channels to which the internal pull-down resistors of the ADCAnIm pins are connected. For details, refer to Section 23.3.11 (3), Diagnosis of Analog Input Pins.

This register is writable only when ADCAnCTL0.ADCAnCE = 0.

Access This register can be read/written in 32-bit units.

Address <ADCAn_base0> + 120_H

Initial value 0000 0000_H

This register is initialized by any reset.

31	30	29	28	27	26	25	24	23	22	21	20	19	18	17	16
0	0	0	0	0	0	0	0	ADCAnPDNA[23:16]							
R	R	R	R	R	R	R	R	R/W	R/W	R/W	R/W	R/W	R/W	R/W	R/W
15	14	13	12	11	10	9	8	7	6	5	4	3	2	1	0
ADCAnPDNA[15:00]															
R/W	R/W	R/W	R/W	R/W	R/W	R/W	R/W	R/W	R/W	R/W	R/W	R/W	R/W	R/W	R/W

Table 23-34 ADCAnPDCTL0 Register Contents

Bit Position	Bit Name	Function
23 to 0	ADCAn PDNA[23:00]	Specifies whether an internal pull-down resistor is connected to CHm: 0: Does not connect an internal pull-down resistor 1: Connects an internal pull-down resistor Note: The bits corresponding to the channels that are not implemented in this product should be cleared to 0 (for the applicable bits, refer to the Number of analog input pins fields in the table in Section 23.1, ADCA Features).

23.4.8 Channel Sample and Hold Function Setting Register

(1) ADCAnSHCTL – A/D Converter Channel Sample and Hold Control Register

This register enables or disables the channel sample and hold function.

This register is writable when ADCAnCTL0.ADCAnCE = 0.

However, it is writable for diagnosis of the channel sample and hold circuit even if ADCAnCTL0.ADCAnCE = 1.

Access This register can be read/written in 8-bit units.

Address <ADCAn_base0> + 118_H

Initial value 00_H

This register is initialized by any reset.

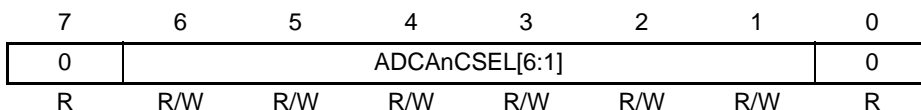

Table 23-35 ADCAnSHCTL Register Contents

Bit Position	Bit Name	Function
6 to 1	ADCAnCSEL[6:1]	Enables or disables the channel’s sample and hold function. 0: The channel’s sample and hold function is disabled. 1: The channel’s sample and hold function is enabled. If diagnosis of the channel’s sample and hold circuit is to be executed, changing the ADCAnSHCTL.ADCAnCSELx is possible even while ADCAnCTL0.ADCAnCE = 1.

23.5 Usage Notes

23.5.1 Range of Channel Input Voltage

Caution The input voltage to the ADCAnIm pin should be within the specified voltage range. If the channel input voltage is above AV_{DD} or below AV_{SS} , the conversion result value of the channel is saturated and it may affect the electric characteristics of the other channels.

23.5.2 Stopping Conversion Operation

Writing 0 to ADCAnCTL0.ADCAnCE during conversion operation stops the operation and the conversion result is not stored in ADCAnCmCR.

23.5.3 Restrictions on Using Channel Sample and Hold Function

Refer to Section 23.3.12 (2), Restrictions when Using Sample and Hold Function.

23.5.4 Application Design Notes

(1) Analog Input Pin (ADCAnIm)

- (a) The input voltage to the ADCAnIm pin should be within the specified voltage range. In order to avoid input of the voltage equal to or above AV_{REFnP} or equal to or below AV_{REFnM} , the input voltage is recommended to be clamped with a diode with a 0.3-V or less V_F . If the voltage equal to or above AV_{REFnP} or equal to or below AV_{REFnM} is input, the conversion result value of the pertinent channel is undefined and cannot be guaranteed. In addition, it may affect the conversion result values of the other channels.
- (b) Noise on the analog input pin (ADCAnIm) should be removed by connecting a resistor R_e between the pertinent pin and the external analog signal input source and a capacitor C_e between the pertinent pin and the AV_{SSn} pin.
- (c) Crossing or close positioning of the analog and digital signal lines should be avoided as much as possible. The A/D conversion characteristics can be degraded due to noise induction or other possible causes.
- (d) For both the input and output ports near the ADCAnIm pin, it is recommended to avoid high current drive and to use toggle switching as infrequently as possible.

(2) Wiring of Power Supply

To minimize the influence on the A/D converter accuracy due to the factors such as switching noise on the digital circuit, the following measures are recommended.

- (a) Use one full side of the board for the power-supply wiring or connect the wiring in as large a grid pattern as possible.
- (b) Insert a bypass capacitor in the vicinity of the pin lead between power supply pins (EV_{DD} , $OSCV_{DD}$, V_{DD} , AV_{DDn}) and ground pins (EV_{SS} , $OSCV_{SS}$, V_{SS} , AV_{SSn}). It is recommended to use approximately 0.1- μ F (reference value) multilayer ceramic capacitors or 4.7- μ F (reference value) or greater tantalum electrolytic capacitors.
- (c) We recommend isolating the analog power supply (AV_{DDn}) from the digital power supply (EV_{DD} , $OSCV_{DD}$, V_{DD}) and supplying power via a series-connected regulator. When a common power supply is to be used, connect the analog power-supply line, digital power-supply line, and an electrolytic capacitor at a point in the source of the supply but wire the power supplies in isolation from each other on the board.

Insert a chip inductor at the point of entry for the analog power supply voltage. In addition, earth the analog ground, digital ground, and an electrolytic capacitor at a point in the source of the power supply, but wire them in isolation from each other on the board.

(3) Analog Reference Voltage Input Pins (AV_{REFnP} , AV_{REFnM})

Insert a bypass capacitor between the leads of the AV_{REFnP} pin and the AV_{REFnM} pin as close as possible to the leads. It is recommended to use approximately 0.1- μ F (reference value) multilayer ceramic capacitors or 4.7- μ F (reference value) or greater tantalum electrolytic capacitors.

(4) Variation in A/D Conversion Results

A/D conversion results may vary according to the factors such as fluctuation of the power supply voltage and noise. Erroneous conversion results may also be produced if noise is generated on the analog input pin ($ADCAnIm$) and reference voltage input pins (AV_{REFnP} , AV_{REFnM}).

To prevent the system from being affected by such variation and erroneous conversion results, reduce them through software.

The following gives examples of using software to prevent bad influence.

- Perform A/D conversion multiple times and use the average value of the results.
- If A/D conversion is continuously performed multiple times and any singular conversion result is obtained, exclude it and use other results.
- If any obtained A/D conversion result is judged to be caused by a system error, do not handle the error immediately; first check to see that the erroneous result is caused again and then handle the error.

(5) Hysteretic Characteristics of A/D Conversion

A successive-approximation A/D converter holds the analog input voltage in the internal common S/H capacitor and then performs A/D conversion. After A/D conversion is completed, the analog input voltage remains in the internal common S/H capacitor. This may cause the following phenomena:

- (a) If the same channel is used for A/D conversion consecutively and the higher or lower voltage is used than the voltage having been used immediately before, the hysteretic characteristics may be presented, in which the conversion result is influenced by the value of the immediately preceding conversion, and the different conversion results may be obtained even for the same potentials. For reference, the hysteretic characteristics have a tendency to be great when the signal source impedance of the analog input pin in the external circuit and the resistor R_e value are large, or the capacitor C_e value is small.
- (b) If the analog input channels are switched to be used for A/D conversion, since a single A/D converter is used, the hysteretic characteristics may be presented, in which the conversion result is influenced by the value of the channel having been used immediately before and the different conversion results may be obtained even for the same potentials.

To obtain the more accurate conversion result, perform A/D conversion two consecutive times using the same channel and ignore the first conversion result.

(6) Wiring and Equivalent Circuit (Reference)

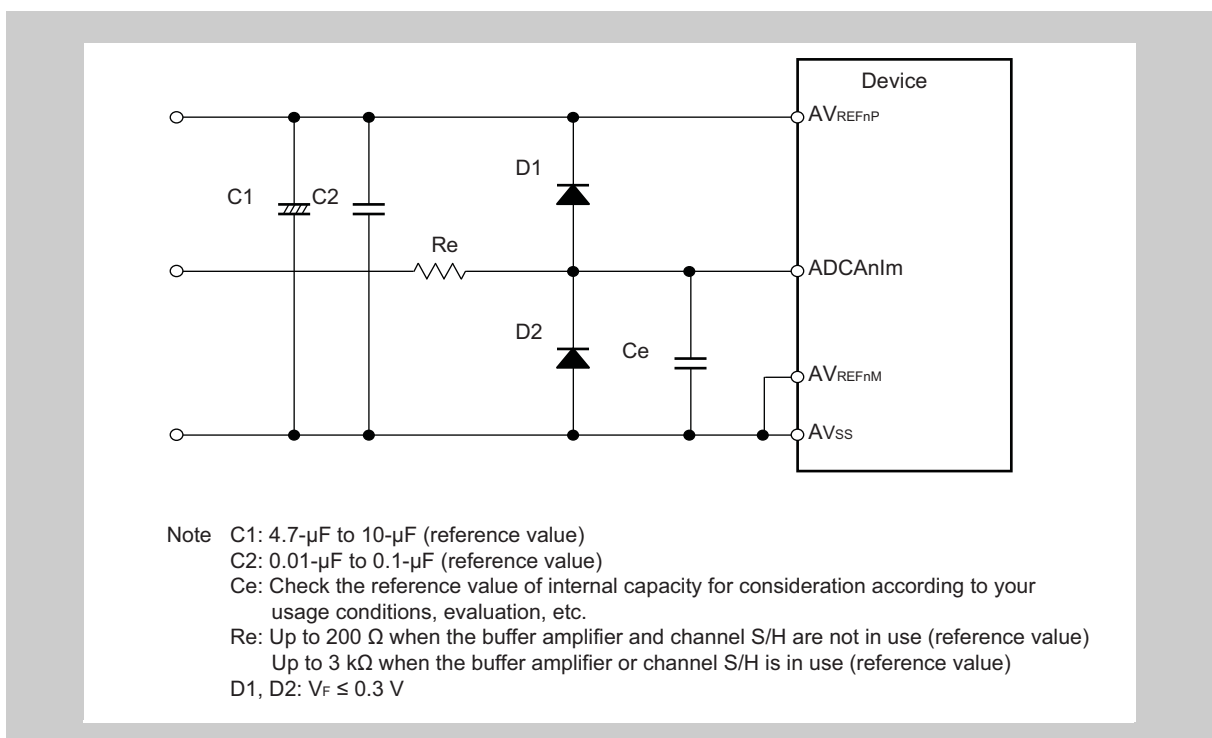

Figure 23-21 Example of Measures against Noise on Analog Input Circuit

The capacitor C1 is effective against low-frequency noise, while capacitors C2 and Ce are effective against high-frequency noise.

Immediately after operation is resumed from the stop state of A/D conversion, the voltages applied to the AV_{DDn} and AV_{REFnP} pins are unstable and it may

degrade the A/D conversion accuracy. In such a case, connect capacitors C1 and C2 to the AV_{DDn} and AV_{REFnP} pins.

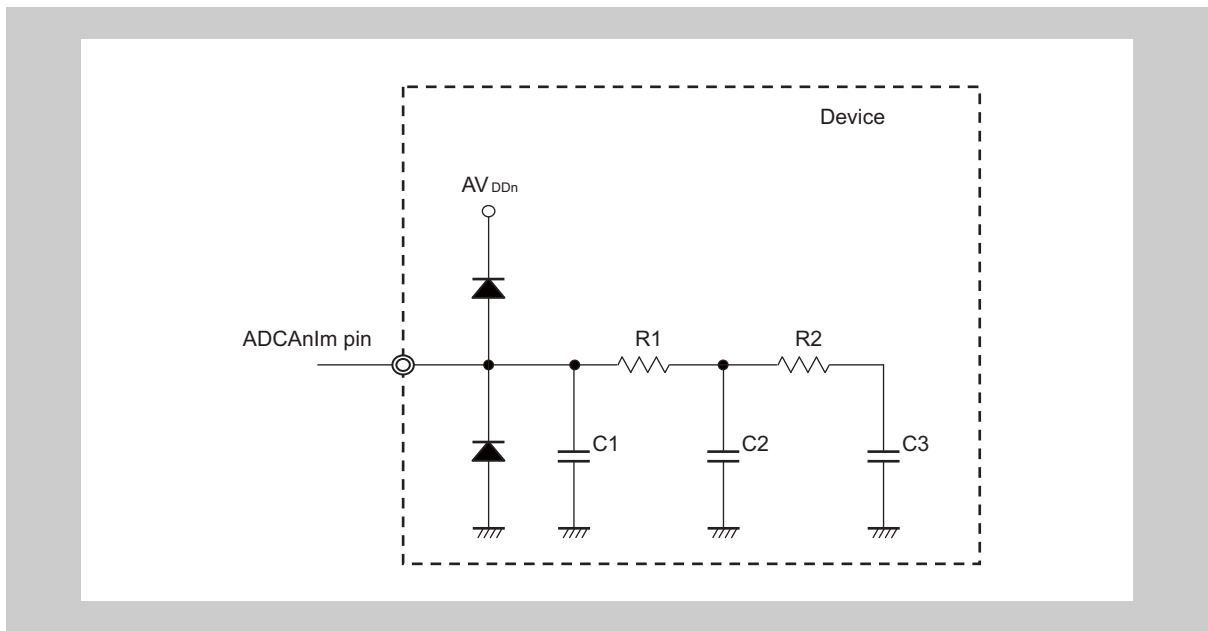

Figure 23-22 Internal Equivalent Circuit of ADCAnIm Pin

Note The following shows the reference values of the circuit constants.

		C1[pF]		C2[pF]		C3[pF]		R1[kΩ]		R2[kΩ]	
		Max	Typ	Max	Typ	Max	Typ	Max	Typ	Max	
Pins supporting channel S/H	Channel S/H used		15	0.64	0.77	1.07	1.28	0.17	0.20	6.30	14.30
	Channel S/H not used	Buffer not used		6.39	7.82	10.00	12.00	0.74	1.39	0.05	0.06
		Buffer used		1.14	1.38	1.00	1.20	0.74	1.39	0.05	0.06
Pins not supporting channel S/H	Buffer not used		5.24	6.44	10.00	12.00	0.23	0.27	0.05	0.06	
	Buffer used		0.52	0.64	1.00	1.20	0.23	0.27	0.05	0.06	

23.6 How to Read A/D Converter Characteristics Table

This section describes the terms specific to the A/D converter.

(1) Resolution

The minimum analog input voltage that can be detected, or the ratio of analog input voltage per one digital output, is called 1 LSB (least significant bit). The ratio of 1 LSB to full scale can be represented in units of %FSR (full scale range). %FSR is the range of the convertible analog input voltage represented in percentage. It is given by the following equation regardless of the resolution.

$$\begin{aligned} 1 \%FSR &= (\text{maximum convertible analog input voltage} - \text{minimum} \\ &\quad \text{convertible analog input voltage})/100 \\ &= (AV_{REFP} - AV_{REFM})/100 \end{aligned}$$

When the resolution is 10 bits, 1 LSB is expressed as follows:

$$\begin{aligned} 1 \text{ LSB} &= 1/2^{10} \\ &= 1/1024 \\ &= 0.098 \%FSR \end{aligned}$$

When the resolution is 12 bits, 1 LSB is expressed as follows:

$$\begin{aligned} 1 \text{ LSB} &= 1/2^{12} \\ &= 1/4096 \\ &= 0.024 \%FSR \end{aligned}$$

The conversion accuracy is determined by the overall error, independent of the resolution.

(2) Overall Error

The overall error is the maximum difference between a measured value and a theoretical value.

It shows the sum of the zero-scale error, full-scale error, linearity error, and the error derived from the combination of these errors.

The quantization error is not included in the overall error in the characteristics table.

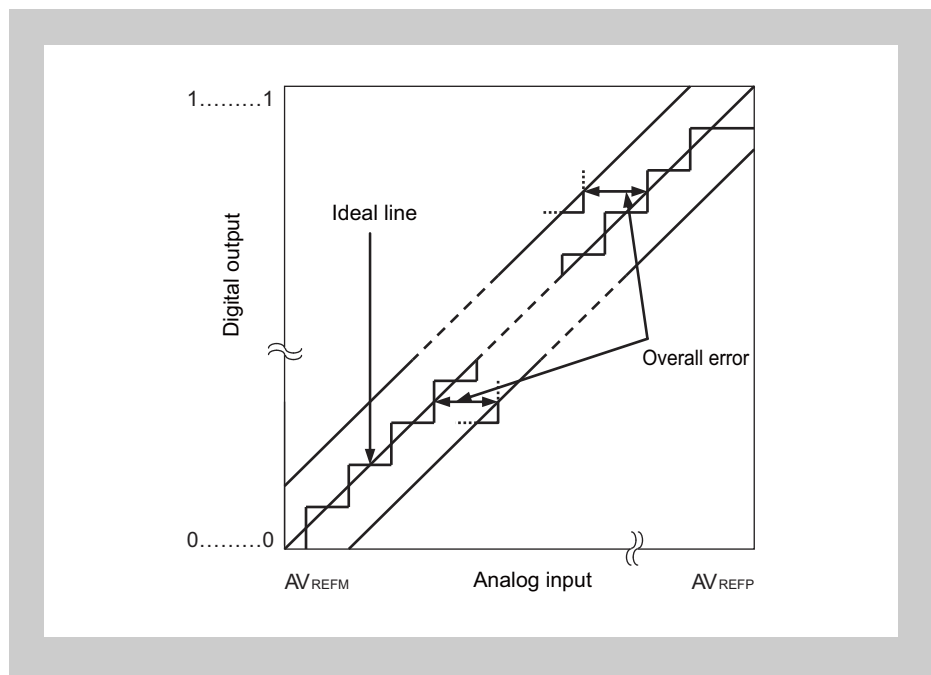

Figure 23-23 Overall Error

(3) Quantization Error

The quantization error is the error of $\pm 1/2$ LSB that is inevitably generated when an analog value is converted to a digital value. The quantization error is unavoidable because analog input voltages within $\pm 1/2$ LSB are converted to the same digital code.

This error is not included in the overall error, zero-scale error, full-scale error, integral linearity error, or differential linearity error in the characteristics table.

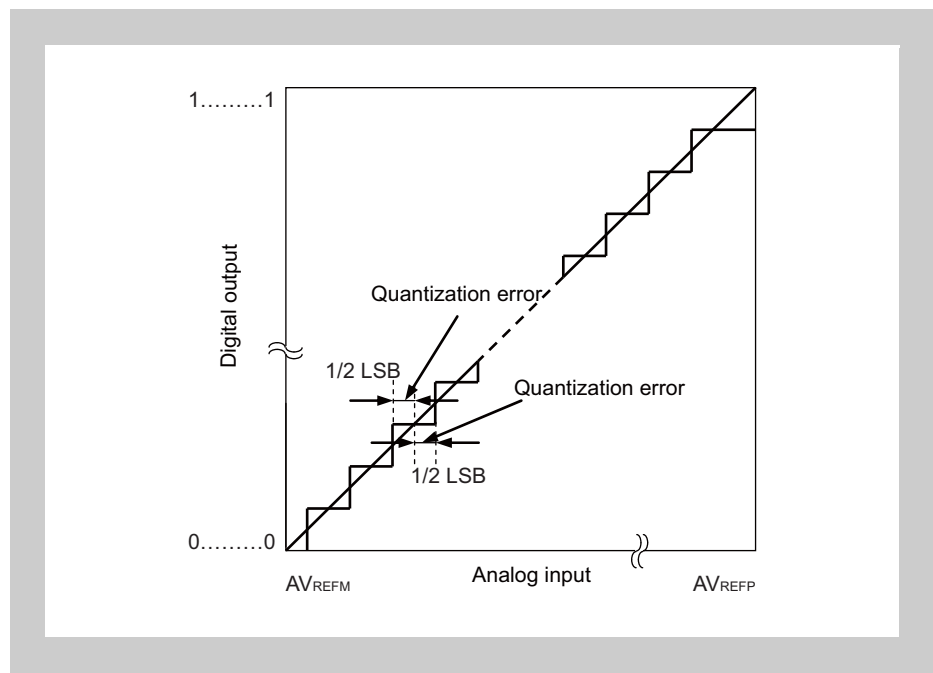

Figure 23-24 Quantization Error

(4) Zero-Scale Error

The zero-scale error is the difference between a measured value and a theoretical value (1/2 LSB) of the analog input voltage when the digital output changes from 0...000 to 0...001.

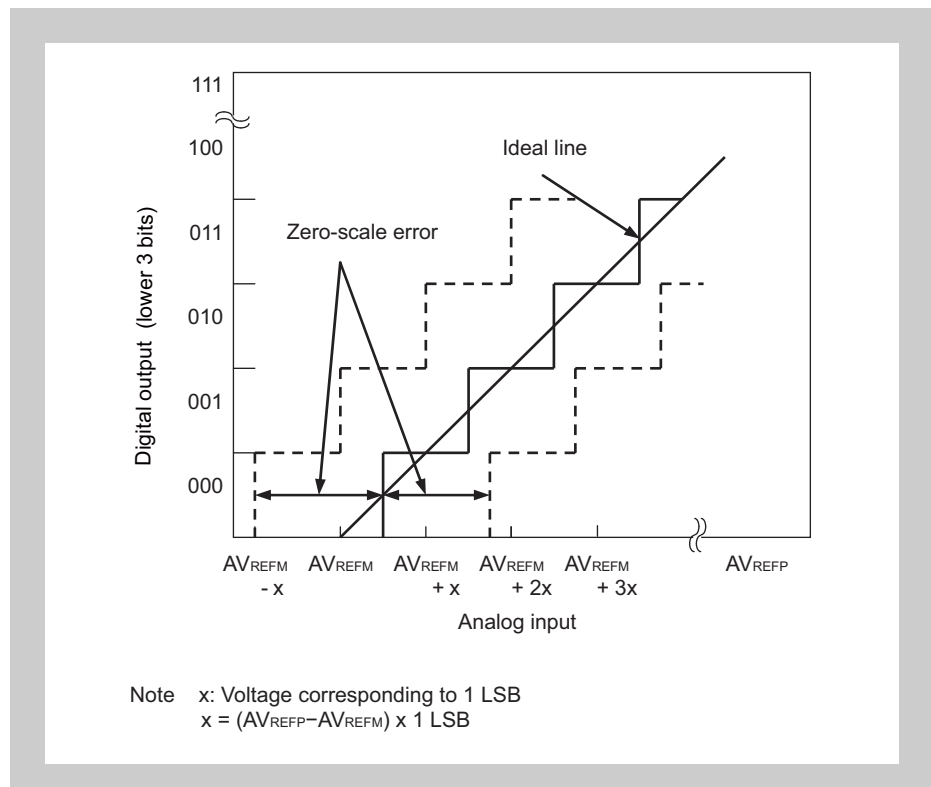

Figure 23-25 Zero-Scale Error

(5) Full-Scale Error

The full-scale error is the difference between a measured value and a theoretical value (full scale - 3/2 LSB) of the analog input voltage when the digital output changes from 1...110 to 1...111.

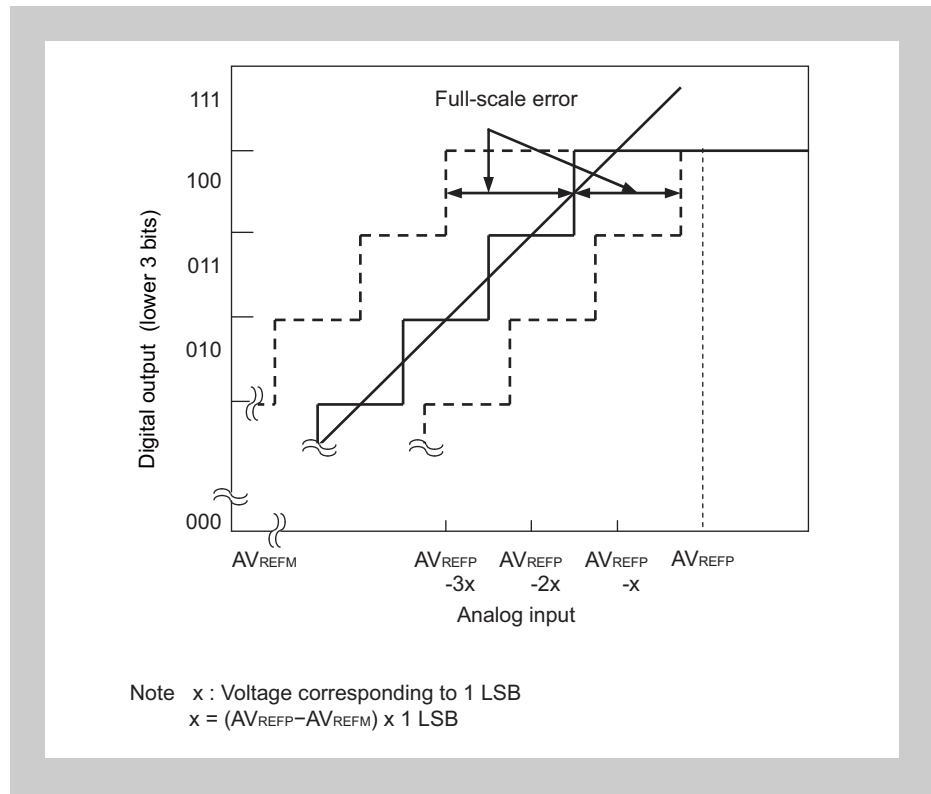

Figure 23-26 Full-Scale Error

(6) Differential Linearity Error

Ideally, the analog input voltage width for outputting a certain code is 1 LSB. The differential linearity error is the difference between a measured value and a theoretical value of the voltage width for outputting a certain code.

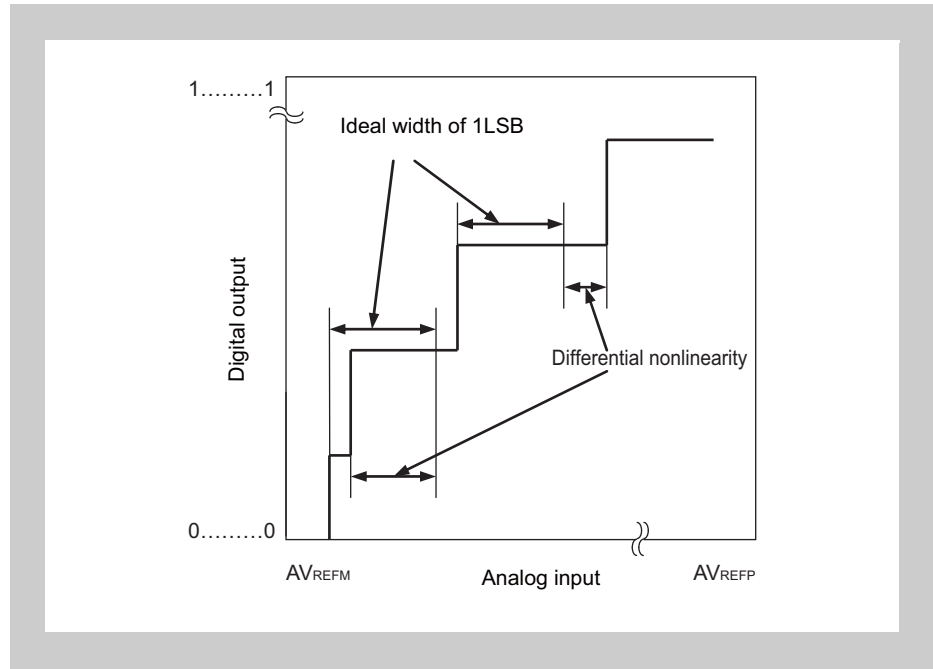

Figure 23-27 Differential Linearity Error

(7) Integral Linearity Error

The integral linearity error is the amount of deviation of the conversion characteristics from the ideal linearity. The integral linearity error is the maximum difference between a measured value and a theoretical value when both the zero-scale error and full-scale error are assumed to be 0.

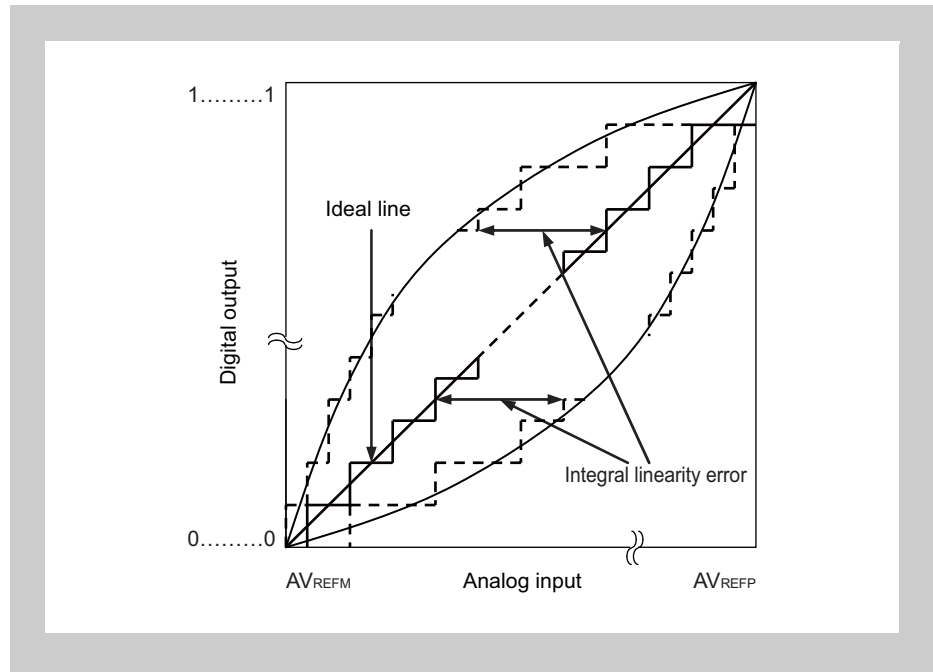

Figure 23-28 Integral Linearity Error

(8) Conversion Time

The conversion time is the time required to obtain the digital output after the analog input voltage is applied.

The conversion time in the characteristics table includes the sampling time.

(9) Sampling Time

The sampling time is the duration while the analog switch is on to allow the analog voltage to be sampled by the common sample and hold circuit.

(10) A/D Conversion Start Time

The A/D conversion start time is the time from occurrence of an A/D conversion trigger to the start of A/D conversion.

Section 24 Peripheral Interconnection (PIC)

24.1 Features of Peripheral Interconnection

The peripheral interconnection (PIC) realizes various functions by synchronous operation using multiple timers and by connecting the timer internal signals between the timers.

Meaning of n The unit number of each timer is represented by affix n (n = 0, 1).

For example, OSTMn represents OSTM0.

Meaning of m The channel number of the timer TAUB0 is represented by affix m (m = 00 to 15)

Meaning of x Arbitrary value set for registers to be used

Meaning of y The registers to be used are identified by affix y (y = 200, 201, 202, 203, 210, 211, 212, 213, 30, 31, 50, 51).

Register addresses Refer to Section 24.3, Peripheral Interconnection Registers.

Clock supply The PIC provides the following clock input. The PIC is connected to the PCLK.

Table 24-1 PIC Clock Supply

PIC	Clock Supply
PIC	PCLK

Input/output signals Refer to Section 24.4, Connection Functions.

24.2 Functional Overview

The PIC has the following functions:

- Simultaneous start trigger function
- A/D conversion trigger selection function
- High accuracy triangle wave PWM output function with dead time
- Trigger and pulse width measurement function
- Encoder capture trigger selection function
- Two-phase encoder function (control method 1)
- Two-phase encoder function (control method 2)
- Three-phase encoder function
- CAN time stamp function
- TSG20+TAUB0 dead-time reduction function
- TAUB input selection function

24.3 Peripheral Interconnection Registers

The functions of the peripheral interconnection are controlled and operated based on the settings of the following registers.

Table 24-2 PIC Registers

Register Name	Symbol	Address
Control register EN	PIC0EN	FFFF DB00 _H
Simultaneous start trigger control register	PIC0SST	FFFF DB04 _H
Simultaneous start control register 0	PIC0SSER0	FFFF DB10 _H
Simultaneous start control register 2	PIC0SSER2	FFFF DB18 _H
Hi-Z output control register 0	PIC0HIZCEN0	FF81 C080 _H
Hi-Z output control register 2	PIC0HIZCEN2	FF81 C088 _H
A/D converter trigger output control register 400	PIC0ADTEN400	FF81 C090 _H
A/D converter trigger output control register 401	PIC0ADTEN401	FF81 C094 _H
A/D converter trigger output control register 402	PIC0ADTEN402	FF81 C098 _H
Timer I/O control register 200	PIC0REG200	FF81 C0C0 _H
Timer I/O control register 201	PIC0REG201	FF81 C0C4 _H
Timer I/O control register 202	PIC0REG202	FF81 C0C8 _H
Timer I/O control register 203	PIC0REG203	FF81 C0CC _H
Timer I/O control register 30	PIC0REG30	FF81 C0E8 _H
Timer I/O control register 31	PIC0REG31	FF81 C0EC _H
Timer I/O control register 50	PIC0REG50	FF81 C0F8 _H

Caution For bit definition for the registers above, refer to the description of the pertinent register.

For signal connection between the timers, various registers are used depending on the functions. The combinations of the control registers to be used for various functions are shown in the following tables.

Table 24-3 Registers for Various Functions (1/2)

Section No.	Function Name	PIC0SSER		PIC0HIZCEN		PIC0ADTEN		
		0	2	0	2	400	401	402
24.4.1	Simultaneous Start Trigger Function	√	√	—	—	—	—	—
24.4.2	ADC Trigger Selection Function	—	—	—	—	√	√	√
24.4.3	High Accuracy Triangle Wave PWM Output Function with Dead Time	—	—	√	—	—	—	—
24.4.4	Trigger and Pulse Width Measurement Function	—	—	—	—	—	—	—
24.4.5	Encoder Capture Trigger Selection Function	—	—	—	—	—	—	—
24.4.6	Two-Phase Encoder Control Function (Control Method 1)	—	—	—	√	—	—	—
24.4.7	Two-Phase Encoder Control Function (Control Method 2)	—	—	—	√	—	—	—
24.4.8	Three-Phase Encoder Control Function	—	—	—	—	—	—	—
24.4.9	CAN Time Stamp Function	—	—	—	—	—	—	—
24.4.10	TSG20 and TAUB0 Dead-Time Reduction Function	—	—	—	—	—	—	—
24.4.11	TAUB Input Selection	—	—	—	—	—	—	—

Table 24-3 Registers for Various Functions (2/2)

Section No.	Function Name	Register Name (PIC0REGy)						
		200	201	202	203	30	31	50
24.4.1	Simultaneous Start Trigger Function	—	—	—	—	—	—	—
24.4.2	ADC Trigger Selection Function	—	—	—	—	—	—	—
24.4.3	High Accuracy Triangle Wave PWM Output Function with Dead Time	√	√	√	√	—	—	—
24.4.4	Trigger and Pulse Width Measurement Function	—	—	—	—	√	√	—
24.4.5	Encoder Capture Trigger Selection Function	—	—	—	—	√	—	—
24.4.6	Two-Phase Encoder Control Function (Control Method 1)	—	—	—	—	√	—	√
24.4.7	Two-Phase Encoder Control Function (Control Method 2)	—	—	—	—	√	—	√
24.4.8	Three-Phase Encoder Control Function	—	—	—	—	√	—	√
24.4.9	CAN Time Stamp Function	—	—	—	—	—	√	—
24.4.10	TSG20 and TAUB0 Dead-Time Reduction Function	√	—	—	—	—	—	√
24.4.11	TAUB Input Selection	√	—	√	—	—	—	—

24.3.1 Start of PIC Function

Set the following register to use the PIC functions.

(1) Control Register EN (PIC0EN)

Access This register can be read/written in 8-bit units.

Address FFFF DB00_H

Initial value 00_H

This register is initialized by any reset.

7	6	5	4	3	2	1	0
0	0	0	0	0	0	0	PIC0EN0
R	R	R	R	R	R	R	R/W

Table 24-4 PIC0EN Contents

Bit Position	Bit Name	Function
0	PIC0EN0	Enables or disables the PIC functions. 0: Disables the PIC functions. 1: Enables the PIC functions.

24.4 Connection Functions

24.4.1 Simultaneous Start Trigger Function

24.4.1.1 Functional Overview

Allows any combination of the timers (TAUB0, TAUJ0, TSG20, TPBA0, OSTMn, and ENCA0) to be started simultaneously.

24.4.1.2 Configuration

Configuration/Timer Function	Timer
Timer configuration	TAUB0, TAUJ0, TSG20, TPBA0, OSTMn, ENCA0

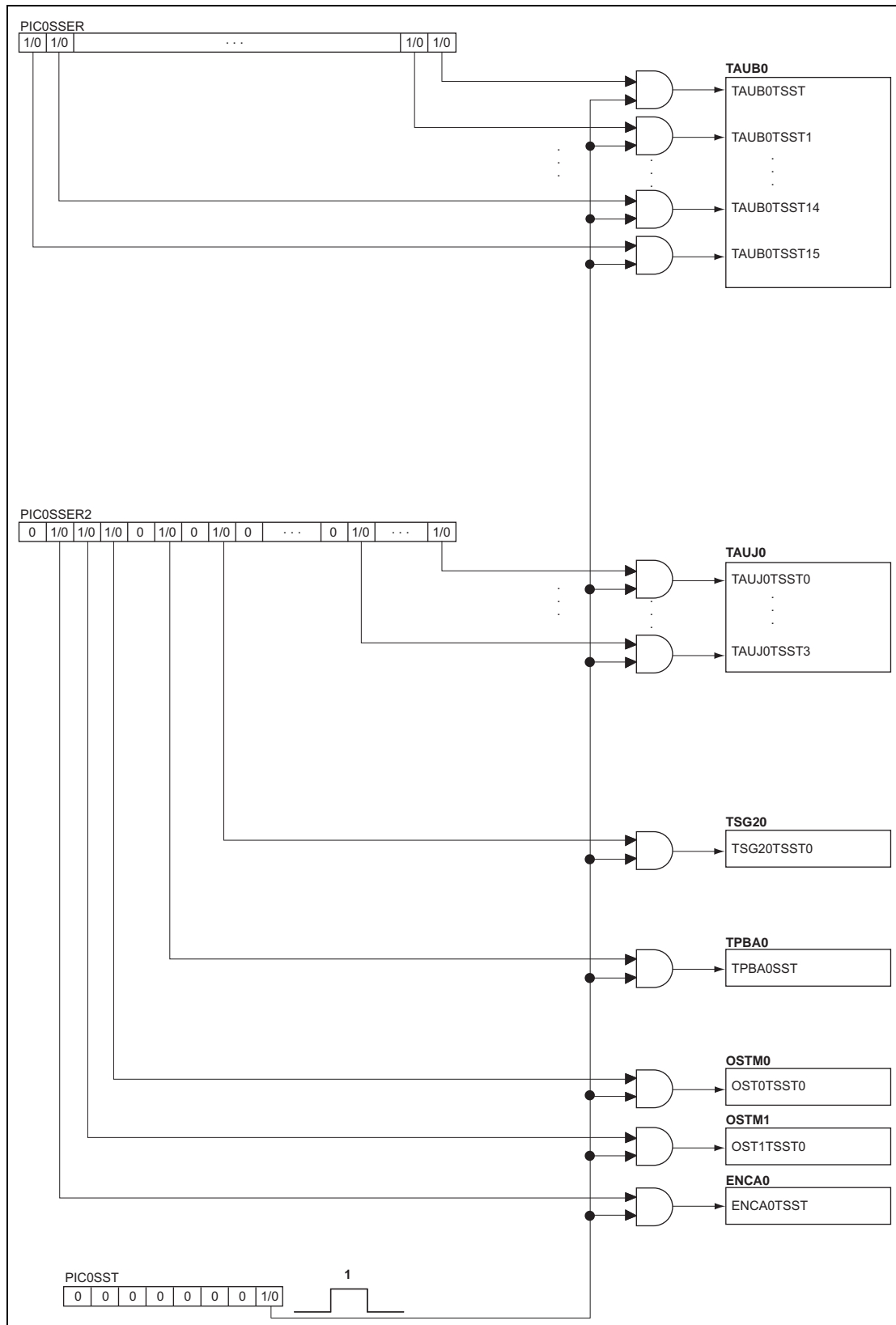

Figure 24-1 Block Diagram

24.4.1.3 Registers

(1) Simultaneous Start Control Register 0 (PIC0SSER0)

The PIC0SSER0 register enables the simultaneous start trigger for the TAUB0 channels.

Access This register can be read/written in 16-bit units.

Address FFFF DB10_H

Initial value 0000_H

This register is initialized by any reset.

15	14	13	12	11	10	9	8
PIC0SS ER015	PIC0SS ER014	PIC0SS ER013	PIC0SS ER012	PIC0SS ER011	PIC0SS ER010	PIC0SS ER009	PIC0SS ER008
R/W	R/W	R/W	R/W	R/W	R/W	R/W	R/W
7	6	5	4	3	2	1	0
PIC0SS ER007	PIC0SS ER006	PIC0SS ER005	PIC0SS ER004	PIC0SS ER003	PIC0SS ER002	PIC0SS ER001	PIC0SS ER000
R/W	R/W	R/W	R/W	R/W	R/W	R/W	R/W

Table 24-5 PIC0SSER0 Contents

Bit Position	Bit Name	Function
m	PIC0SSER0m	Enables the simultaneous start trigger for CHm of TAUB0. 0: Disables the simultaneous start trigger for CHm of TAUB0. 1: Enables the simultaneous start trigger for CHm of TAUB0.

(2) Simultaneous Start Control Register 2 (PIC0SSER2)

The PIC0SSER2 register enables the simultaneous start trigger for the TAUJ, TSG2, TPBA, OSTM, ENCA channels.

Access This register can be read/written in 16-bit units.

Address FFFF DB18_H

Initial value 0000_H

This register is initialized by any reset.

15	14	13	12	11	10	9	8
0	PIC0SS ER214	PIC0SS ER213	PIC0SS ER212	0	PIC0SS ER210	0	PIC0SS ER208
R	R/W	R/W	R/W	R	R/W	R	R/W
7	6	5	4	3	2	1	0
0	0	0	0	PIC0SS ER203	PIC0SS ER202	PIC0SS ER201	PIC0SS ER200
R	R	R	R	R/W	R/W	R/W	R/W

Table 24-6 PIC0SSER2 Contents

Bit Position	Bit Name	Function
14	PIC0SSER214	Enables the simultaneous start trigger for ENCA0. 0: Disables the simultaneous start trigger for ENCA0. 1: Enables the simultaneous start trigger for ENCA0.
13	PIC0SSER213	Enables the simultaneous start trigger for OSTM1. 0: Disables the simultaneous start trigger for OSTM1. 1: Enables the simultaneous start trigger for OSTM1.
12	PIC0SSER212	Enables the simultaneous start trigger for OSTM0. 0: Disables the simultaneous start trigger for OSTM0. 1: Enables the simultaneous start trigger for OSTM0.
10	PIC0SSER210	Enables the simultaneous start trigger for TPBA0. 0: Disables the simultaneous start trigger for TPBA0. 1: Enables the simultaneous start trigger for TPBA0.
8	PIC0SSER208	Enables the simultaneous start trigger for TSG20. 0: Disables the simultaneous start trigger for TSG20. 1: Enables the simultaneous start trigger for TSG20.
3	PIC0SSER203	Enables the simultaneous start trigger for CH03 of TAUJ0. 0: Disables the simultaneous start trigger for CH03 of TAUJ0. 1: Enables the simultaneous start trigger for CH03 of TAUJ0.
2	PIC0SSER202	Enables the simultaneous start trigger for CH02 of TAUJ0. 0: Disables the simultaneous start trigger for CH02 of TAUJ0. 1: Enables the simultaneous start trigger for CH02 of TAUJ0.
1	PIC0SSER201	Enables the simultaneous start trigger for CH01 of TAUJ0. 0: Disables the simultaneous start trigger for CH01 of TAUJ0. 1: Enables the simultaneous start trigger for CH01 of TAUJ0.
0	PIC0SSER200	Enables the simultaneous start trigger for CH00 of TAUJ0. 0: Disables the simultaneous start trigger for CH00 of TAUJ0. 1: Enables the simultaneous start trigger for CH00 of TAUJ0.

(3) Simultaneous Start Trigger Control Register (PIC0SST)**Access** This register can be written in 8- or 1-bit units.**Address** FFFF DB04_H**Initial value** 00_H

This register is initialized by any reset.

7	6	5	4	3	2	1	0
0	0	0	0	0	0	0	SYNCTRG
W	W	W	W	W	W	W	W

Table 24-7 PIC0SST Contents

Bit Position	Bit Name	Function
0	SYNCTRG	Generates a start trigger for the timers for which simultaneous start is enabled. 0: Invalid 1: Generates a simultaneous start trigger. (Outputs a pulse of 1-PCLK wide.)

SYNCTRG is always read as 0.

24.4.1.4 Example of Operation

(1) Operation Example of Timer Configuration

In this example, an arbitrary combination of multiple timers (from among TAUB0, TAUJ0, TSG20, TPBA0, OSTMn, and ENCA0) that operate in arbitrary modes is started simultaneously.

(2) Setting Procedure

1. Initial Setting
Set the operating mode for each of the timers TAUB0, TAUJ0, TSG20, TPBA0, OSTMn, and ENCA0 (register setting is included). (For details on initial setting of TAUB0, TAUJ0, TSG20, TPBA0, OSTMn, and ENCA0, see the section of each timer.)
2. Enabling Simultaneous Start
Enable simultaneous start of the target timers by setting the corresponding bits in PIC0SSER0 and PIC0SSER2 to 1.
3. Start Trigger Output
Set the SYNCTRG bit in PIC0SST0 to 1 to start the timers selected in step 2 simultaneously.
4. Repeat steps 2 and 3 for the channels that are not yet started. This allows each of the different target timer groups to be started simultaneously in separate timing.

24.4.1.5 Operation Flow

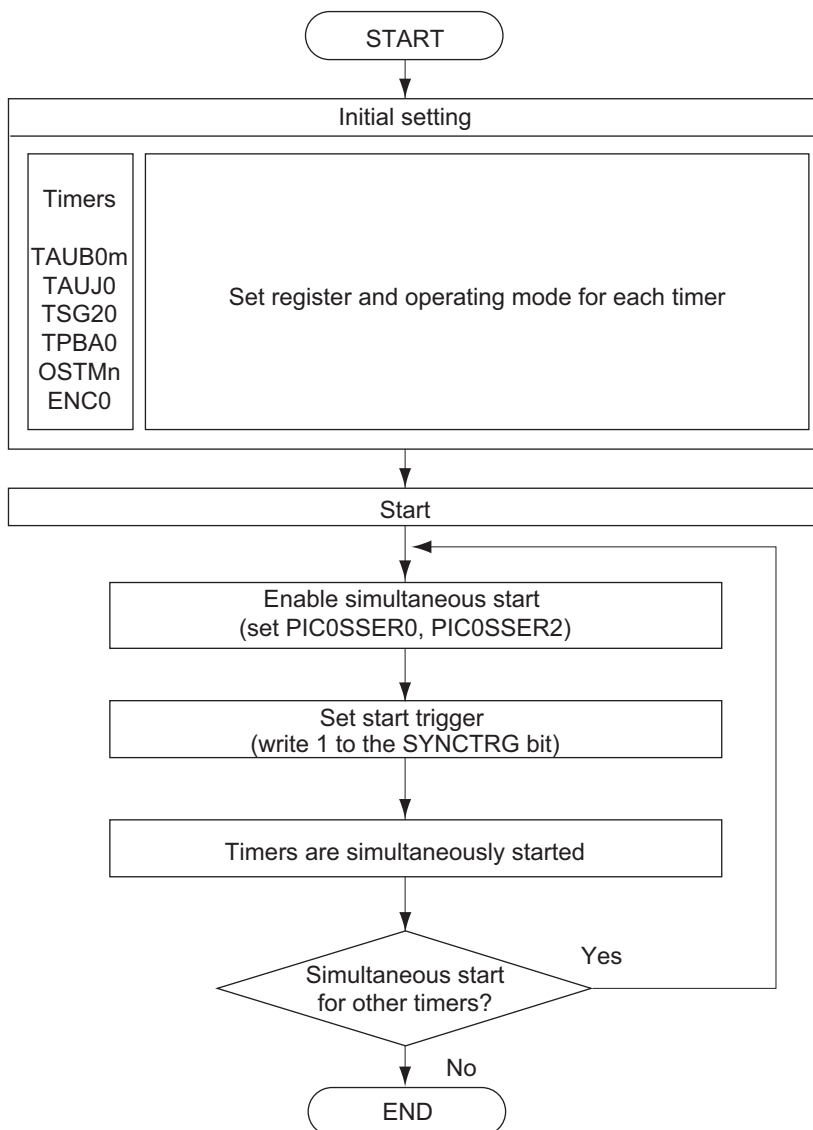

Figure 24-2 Setting Flow

Note For operation of the timers in simultaneous start function, refer to the section of each timer.

24.4.1.6 Register Setting for Various Functions

Refer to Section 24.4.1.3, Registers.

24.4.2 ADC Trigger Selection Function

24.4.2.1 Functional Overview

The ADC consists of three channel groups and provides the ADC hardware triggers corresponding to each of the channel groups.

The internal trigger signals selected by ADCA0TSEL0 from TAUB0, ENCA0, and TSG20 are ORed with the external trigger signal from the pin and the result can be input as the ADC hardware trigger signal for the pertinent channel group. Similarly, the internal trigger signals selected by ADCA0TSEL1 and ADCA0TSEL2 from TAUB0, ENCA0, TSG20, and TAPA0 are ORed with the external trigger signal from the pin to generate the ADC hardware trigger signal for the pertinent channel groups.

The PIC provides the function to allow TAUB0INTm (internal trigger signal from each of TAUB0 described above) to be selected as the ADC hardware trigger signal.

Caution The trigger signals from the TAUB0 channels are not controlled by the TAUB0CMORm.TAUB0MD0. Accordingly, they are used as the ADC hardware trigger signals for all the interrupts.

24.4.2.2 Configuration

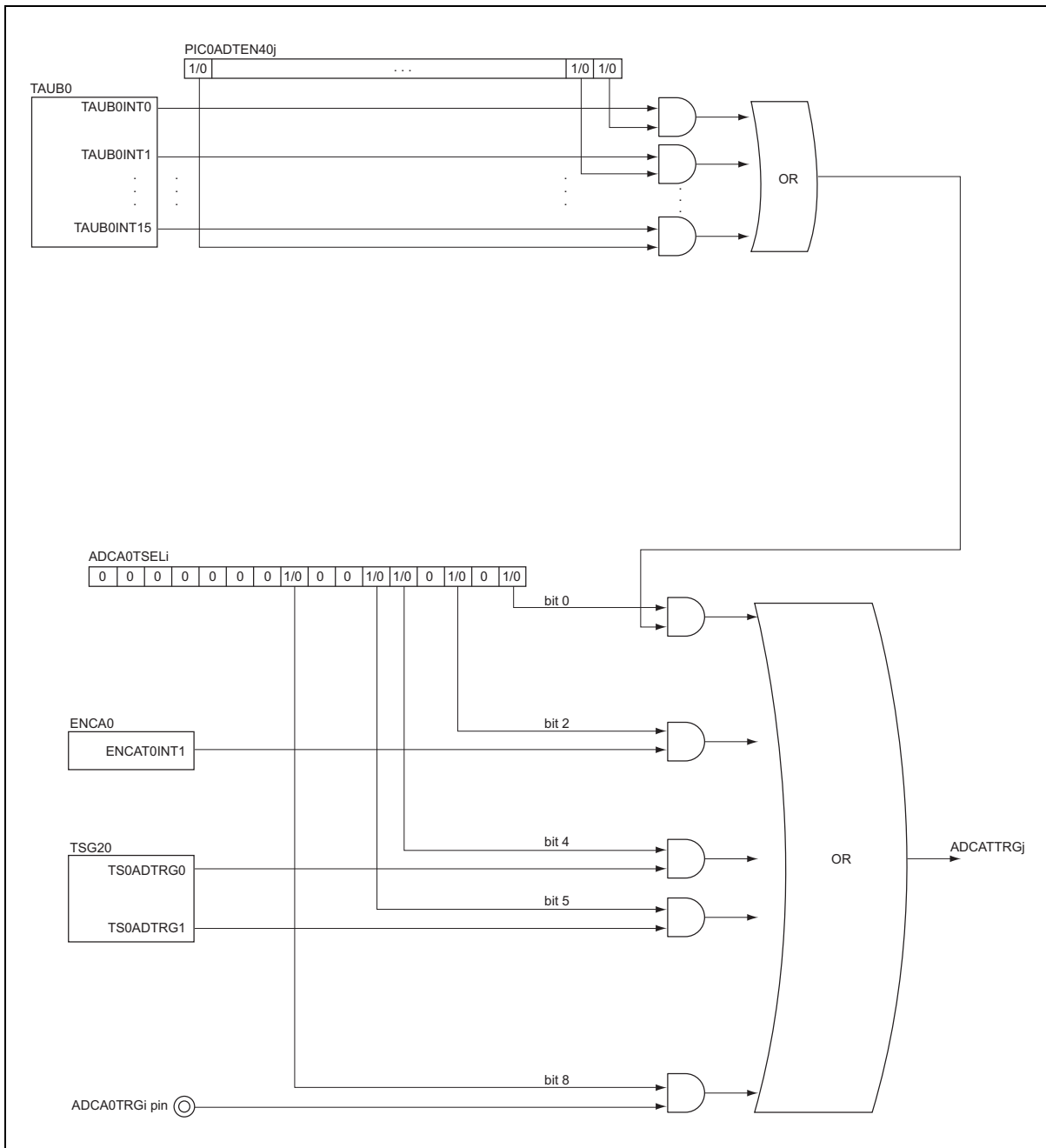

Figure 24-3 Block Diagram (i = 0, j = 0 to 2)

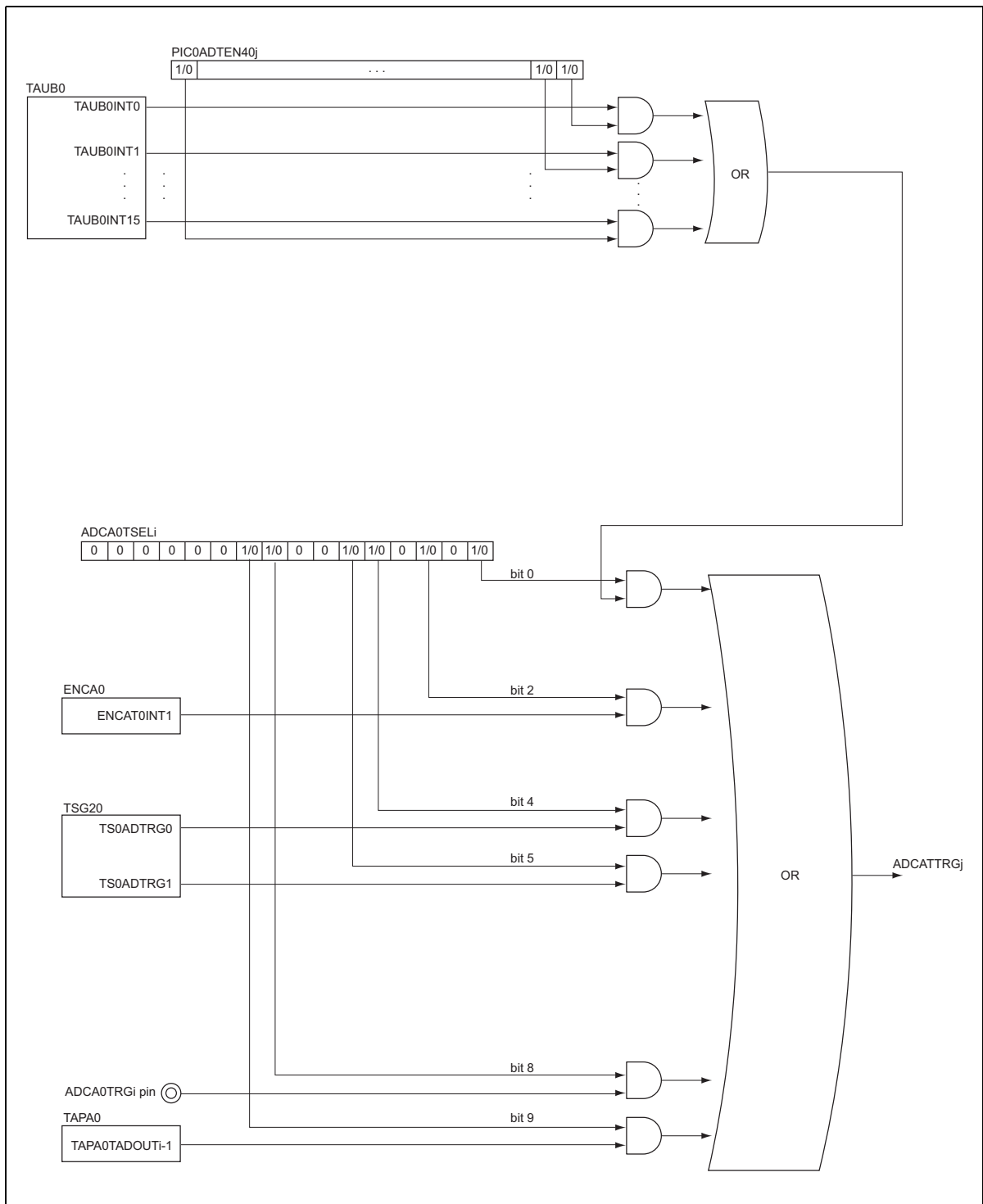

Figure 24-4 Block Diagram (i = 1 or 2, j = 0 to 2)

24.4.2.3 Registers

(1) A/D Converter Trigger Output Control Register 40j (PIC0ADTEN40j)

The PIC0ADTEN0j register (j = 0 to 2) enables a trigger source from TAUB0 CHm to be selected as an ADC trigger.

Access This register can be read/written in 16-bit units.

Address FF81 C090_H (j = 0), FF81 C094_H (j = 1), FF81 C098_H (j = 2)

Initial value 0000_H

This register is initialized by any reset.

15	14	13	12	11	10	9	8
PIC0 ADTEN 40j15	PIC0 ADTEN 40j14	PIC0 ADTEN 40j13	PIC0 ADTEN 40j12	PIC0 ADTEN 40j11	PIC0 ADTEN 40j10	PIC0 ADTEN 40j09	PIC0 ADTEN 40j08
R/W	R/W	R/W	R/W	R/W	R/W	R/W	R/W
7	6	5	4	3	2	1	0
PIC0 ADTEN 40j07	PIC0 ADTEN 40j06	PIC0 ADTEN 40j05	PIC0 ADTEN 40j04	PIC0 ADTEN 40j03	PIC0 ADTEN 40j02	PIC0 ADTEN 40j01	PIC0 ADTEN 40j00
R/W	R/W	R/W	R/W	R/W	R/W	R/W	R/W

Table 24-8 PIC0ADTEN40j Contents

Bit Position	Bit Name	Function
m	PIC0ADTEN40jm	Sets a trigger source from TAUB0 CHm. 0: Disables a trigger source from TAUB0 CHm to be selected as an ADC trigger. 1: Enables a trigger source from TAUB0 CHm to be selected as an ADC trigger.

(2) A/D Converter Trigger Selection Control Register i (ADCA0TSELi)

The ADCA0TSELi register selects a trigger for the ADC channel group i. (i = 0 to 2)

Access This register can be read/written in 16-bit units.

Address FF81 D108_H (i = 0), FF81 D10C_H (i = 1), FF81 D110_H (i = 2)

Initial value 0000_H

This register is initialized by any reset.

15	14	13	12	11	10	9* ¹	8
0	0	0	0	0	0	ADCA0 TiSEL09	ADCA0 TiSEL08
R	R	R	R	R	R	R/W	R/W
7	6	5	4	3	2	1	0
0	0	ADCA0 TiSEL05	ADCA0 TiSEL04	0	ADCA0 TiSEL02	0	ADCA0 TiSEL00
R	R	R/W	R/W	R	R/W	R	R/W

Note 1. i = 1 and 2 for bit 9.

Table 24-9 ADCA0TSELi Contents (i = 0, j = 0 to 2)

Bit Position	Bit Name	Function
8	ADCA0TiSEL08	Selects the ADTRG0i pin as a trigger source of ADC channel group i. 0: Does not select the ADTRG0i pin as a trigger source. 1: Selects the ADTRG0i pin as a trigger source.
5	ADCA0TiSEL05	Selects TS0ADTRG1 as a trigger source of ADC channel group i. 0: Does not select TS0ADTRG1 as a trigger source. 1: Selects TS0ADTRG1 as a trigger source.
4	ADCA0TiSEL04	Selects TS0ADTRG0 as a trigger source of ADC channel group i. 0: Does not select TS0ADTRG0 as a trigger source. 1: Selects TS0ADTRG0 as a trigger source.
2	ADCA0TiSEL02	Selects ENCAT0INT1 as a trigger source of ADC channel group i. 0: Does not select ENCAT0INT1 as a trigger source. 1: Selects ENCAT0INT1 as a trigger source.
0	ADCA0TiSEL00	Selects the trigger selected by the PIC0ADTEN40j register as a trigger source of ADC channel group i. 0: Does not select the trigger selected by the PIC0ADTEN40j register as a trigger source. 1: Selects the trigger selected by the PIC0ADTEN40j register as a trigger source.

Table 24-10 ADCA0TSELi Contents (i = 1, 2, j = 0 to 2)

Bit Position	Bit Name	Function
9	ADCA0TiSEL09	Selects the TAPA0TADOUTi-1 pin as a trigger source of ADC channel group i. 0: Does not select the TAPA0TADOUTi-1 pin as a trigger source. 1: Selects the TAPA0TADOUTi-1 pin as a trigger source.
8	ADCA0TiSEL08	Selects the ADTRG0i pin as a trigger source of ADC channel group i. 0: Does not select the ADTRG0i pin as a trigger source. 1: Selects the ADTRG0i pin as a trigger source.
5	ADCA0TiSEL05	Selects TS0ADTRG1 as a trigger source of ADC channel group i. 0: Does not select TS0ADTRG1 as a trigger source. 1: Selects TS0ADTRG1 as a trigger source.
4	ADCA0TiSEL04	Selects TS0ADTRG0 as a trigger source of ADC channel group i. 0: Does not select TS0ADTRG0 as a trigger source. 1: Selects TS0ADTRG0 as a trigger source.
2	ADCA0TiSEL02	Selects ENCAT0INT1 as a trigger source of ADC channel group i. 0: Does not select ENCAT0INT1 as a trigger source. 1: Selects ENCAT0INT1 as a trigger source.
0	ADCA0TiSEL00	Selects the trigger selected by the PIC0ADTEN40j register as a trigger source of ADC channel group i. 0: Does not select the trigger selected by the PIC0ADTEN40j register as a trigger source. 1: Selects the trigger selected by the PIC0ADTEN40j register as a trigger source.

24.4.2.4 Example of Operation

1. Initial Setting
Set the timers to use from among TAUB0, ENCA0, TSG20, and TAPA0.
(Refer to the specification of each timer for detailed initial setting procedure.)
2. Setting A/D Converter Trigger Output Control Register 40j (PIC0ADTEN40j)
Set bit m in the A/D converter trigger output control register 40j (PIC0ADTEN40j; j = 0 to 2) to 1 to allow the interrupt trigger signal from each channel of TAUB0 to be selected as a trigger of ADC channel group i.

Note Set the registers while the AD converter is stopped (ADCA0CE = 0).

3. Setting A/D Converter Trigger Selection Control Register i (ADCA0TSELi)
By setting the bit corresponding to each trigger to 1, the trigger signals are ORed and the result can be used as a trigger for ADC channel group i.

Note Set the registers while the AD converter is stopped (ADCA0CE = 0).

4. Enabling TAUB0, ENCA0, TSG20, and TAPA0 Operation
Timers selected in step 1 from among TAUB0, ENCA0, TSG20, and TAPA0 are started.

24.4.2.5 Operation Flow

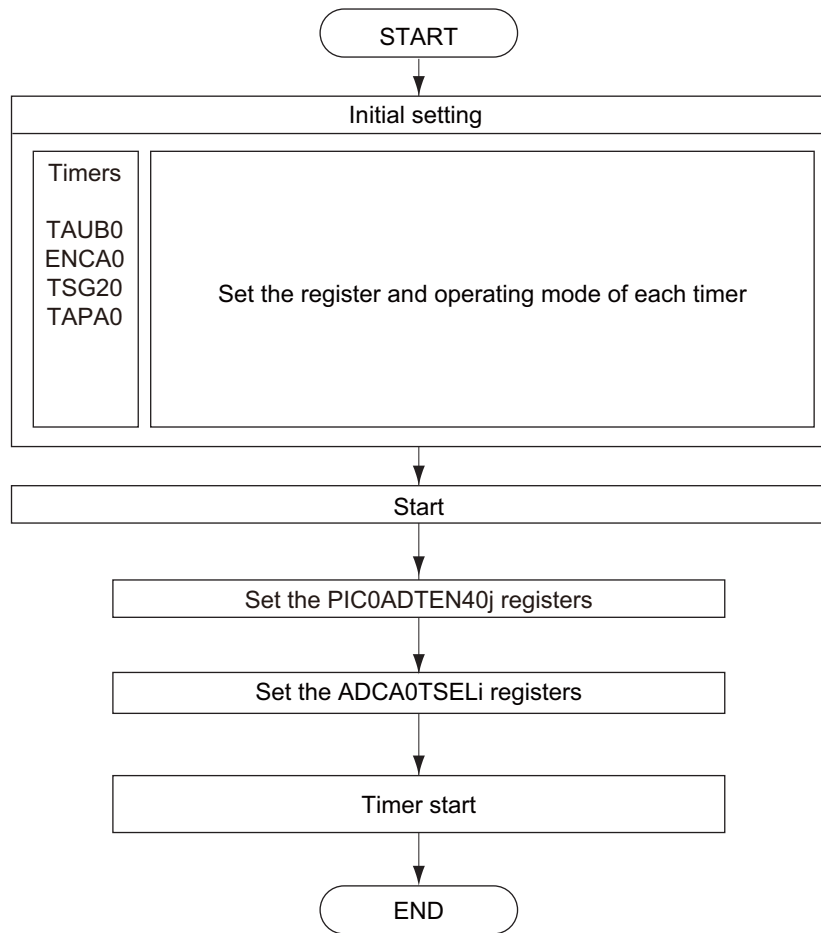

Figure 24-5 Operation Flow (i = 0 to 2, j = 0 to 2)

24.4.2.6 Register Setting Examples for Various Functions

Refer to Section 24.4.1.3, Registers.

24.4.3 High Accuracy Triangle Wave PWM Output Function with Dead Time

24.4.3.1 Functional Overview

This function enables a control of the variable dead time range (where duty cycle is close to 100% and 0%), thus providing the more accurate triangle wave PWM output than that provided by the triangle wave PWM output function with the dead time.

24.4.3.2 Configuration

Note In this section, signal names are abbreviated as shown below.

INT_m → TAUB0INT_m
 TIN_m → TAUB0TTIN_m
 TOUT_m → TAUB00TTOUT_m
 CDR_m → TAUB0CDR_m
 CNT_m → TAUB0CNT_m

Configuration/ Timer Function	TAUB	TAPA
Timer configuration	TAUB0	TAPA0

- Setting functions of TAUB0 channels

CH	Function Name	M/S*	CDR Set Value	Description
02	PWM output function (CH02 is master for CH04 to CH09.)	M	Period	
04		S	Duty (U phase setting)	
05		S	Dead time (U phase)	
06		S	Duty (V phase setting)	
07		S	Dead time (V phase)	
08		S	Duty (W phase setting)	
09		S	Dead time (W phase)	
10		One-shot pulse output function	M	Delay
11	S		Pulse width	
12	One-shot pulse output function	M	Delay	Generates pulses to be inserted into V phase PWM in variable dead time range.
13		S	Pulse width	
14	One-shot pulse output function	M	Delay	Generates pulses to be inserted into W phase PWM in variable dead time range.
15		S	Pulse width	

Note * M = master channel, S = slave channel

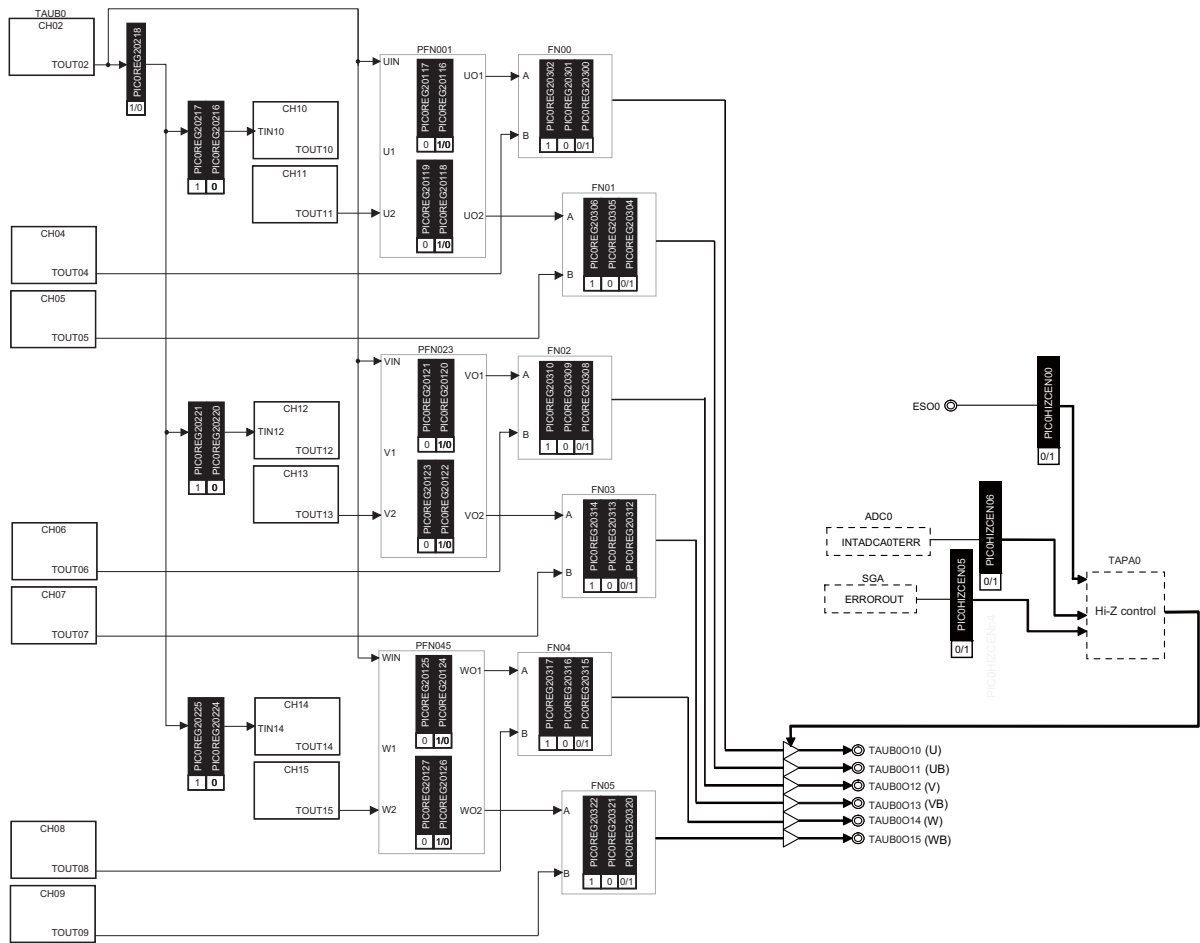

Figure 24-6 Block Diagram

24.4.3.3 Registers

(1) Timer I/O Control Register 200 (PIC0REG200)

Access This register can be read/written in 32-bit units.

Address FF81 C0C0_H

Initial value 0000 0000_H

This register is initialized by any reset.

31	30	29	28	27	26	25	24
0	0	0	0	0	0	0	0
R	R	R	R	R	R	R	R
23	22	21	20	19	18	17	16
0	0	0	0	0	PIC0REG20018	0	0
R	R	R	R	R	R/W	R	R
15	14	13	12	11	10	9	8
0	0	0	0	0	0	0	0
R	R	R	R	R	R	R	R
7	6	5	4	3	2	1	0
0	0	0	0	0	0	0	0
R	R	R	R	R	R	R	R

Table 24-11 PIC0REG200 Contents

Bit Position	Bit Name	Function
18	PIC0REG20018	Selects the TIN input signal of TAUB0CH10, TAUB0CH12, and TAUB0CH14. 0: Setting is prohibited. 1: Selects TOUT of TAUB0CH02.

Caution The bit might be defined to 0 by other timer connection functions. In that case, apply the bit definition of the corresponding PIC connection function.

(2) Timer I/O Control Register 201 (PIC0REG201)

Access This register can be read/written in 32-bit units.

Address FF81 C0C4_H

Initial value 0000 0000_H

This register is initialized by any reset.

31	30	29	28	27	26	25	24
0	0	0	0	PIC0REG G20127	PIC0REG G20126	PIC0REG G20125	PIC0REG G20124
R	R	R	R	R/W	R/W	R/W	R/W
23	22	21	20	19	18	17	16
PIC0REG G20123	PIC0REG G20122	PIC0REG G20121	PIC0REG G20120	PIC0REG G20119	PIC0REG G20118	PIC0REG G20117	PIC0REG G20116
R/W	R/W	R/W	R/W	R/W	R/W	R/W	R/W
15	14	13	12	11	10	9	8
0	0	0	0	0	0	0	0
R	R	R	R	R	R	R	R
7	6	5	4	3	2	1	0
0	0	0	0	0	0	0	0
R	R	R	R	R	R	R	R

Table 24-12 PIC0REG201 Contents (1/2)

Bit Position	Bit Name	Function												
27 26	PIC0REG20127 PIC0REG20126	Selects the A input signal of FN05 according to the setting of the TOL bit of TAUB0CH09. <table border="1" style="width: 100%; margin-top: 5px;"> <thead> <tr> <th>PIC0REG20127</th> <th>PIC0REG20126</th> <th>Input Signal</th> </tr> </thead> <tbody> <tr> <td>1</td> <td>0</td> <td>Output from the combinational circuit (When TOL of TAUB0CH09 is 0)</td> </tr> <tr> <td>1</td> <td>1</td> <td>Inverted output from the combinational circuit (When TOL of TAUB0CH09 is 1)</td> </tr> <tr> <td colspan="2">Other than the above</td> <td>Setting is prohibited.</td> </tr> </tbody> </table>	PIC0REG20127	PIC0REG20126	Input Signal	1	0	Output from the combinational circuit (When TOL of TAUB0CH09 is 0)	1	1	Inverted output from the combinational circuit (When TOL of TAUB0CH09 is 1)	Other than the above		Setting is prohibited.
PIC0REG20127	PIC0REG20126	Input Signal												
1	0	Output from the combinational circuit (When TOL of TAUB0CH09 is 0)												
1	1	Inverted output from the combinational circuit (When TOL of TAUB0CH09 is 1)												
Other than the above		Setting is prohibited.												
25 24	PIC0REG20125 PIC0REG20124	Selects the A input signal of FN04 according to the setting of the TOL bit of TAUB0CH08. <table border="1" style="width: 100%; margin-top: 5px;"> <thead> <tr> <th>PIC0REG20125</th> <th>PIC0REG20124</th> <th>Input Signal</th> </tr> </thead> <tbody> <tr> <td>1</td> <td>0</td> <td>Output from the combinational circuit (When TOL of TAUB0CH08 is 0)</td> </tr> <tr> <td>1</td> <td>1</td> <td>Inverted output from the combinational circuit (When TOL of TAUB0CH08 is 1)</td> </tr> <tr> <td colspan="2">Other than the above</td> <td>Setting is prohibited.</td> </tr> </tbody> </table>	PIC0REG20125	PIC0REG20124	Input Signal	1	0	Output from the combinational circuit (When TOL of TAUB0CH08 is 0)	1	1	Inverted output from the combinational circuit (When TOL of TAUB0CH08 is 1)	Other than the above		Setting is prohibited.
PIC0REG20125	PIC0REG20124	Input Signal												
1	0	Output from the combinational circuit (When TOL of TAUB0CH08 is 0)												
1	1	Inverted output from the combinational circuit (When TOL of TAUB0CH08 is 1)												
Other than the above		Setting is prohibited.												

Table 24-12 PIC0REG201 Contents (2/2)

Bit Position	Bit Name	Function												
23 22	PIC0REG20123 PIC0REG20122	<p>Selects the A input signal of FN03 according to the setting of the TOL bit for TAUB0CH07.</p> <table border="1"> <thead> <tr> <th>PIC0REG20123</th> <th>PIC0REG20122</th> <th>Input Signal</th> </tr> </thead> <tbody> <tr> <td>1</td> <td>0</td> <td>Output from the combinational circuit (When TOL of TAUB0CH07 is 0)</td> </tr> <tr> <td>1</td> <td>1</td> <td>Inverted output from the combinational circuit (When TOL of TAUB0CH07 is 1)</td> </tr> <tr> <td colspan="2">Other than the above</td> <td>Setting is prohibited.</td> </tr> </tbody> </table>	PIC0REG20123	PIC0REG20122	Input Signal	1	0	Output from the combinational circuit (When TOL of TAUB0CH07 is 0)	1	1	Inverted output from the combinational circuit (When TOL of TAUB0CH07 is 1)	Other than the above		Setting is prohibited.
PIC0REG20123	PIC0REG20122	Input Signal												
1	0	Output from the combinational circuit (When TOL of TAUB0CH07 is 0)												
1	1	Inverted output from the combinational circuit (When TOL of TAUB0CH07 is 1)												
Other than the above		Setting is prohibited.												
21 20	PIC0REG20121 PIC0REG20120	<p>Selects the A input signal of FN02 according to the setting of the TOL bit for TAUB0CH06.</p> <table border="1"> <thead> <tr> <th>PIC0REG20121</th> <th>PIC0REG20120</th> <th>Input Signal</th> </tr> </thead> <tbody> <tr> <td>1</td> <td>0</td> <td>Output from the combinational circuit (When TOL of TAUB0CH06 is 0)</td> </tr> <tr> <td>1</td> <td>1</td> <td>Inverted output from the combinational circuit (When TOL of TAUB0CH06 is 1)</td> </tr> <tr> <td colspan="2">Other than the above</td> <td>Setting is prohibited.</td> </tr> </tbody> </table>	PIC0REG20121	PIC0REG20120	Input Signal	1	0	Output from the combinational circuit (When TOL of TAUB0CH06 is 0)	1	1	Inverted output from the combinational circuit (When TOL of TAUB0CH06 is 1)	Other than the above		Setting is prohibited.
PIC0REG20121	PIC0REG20120	Input Signal												
1	0	Output from the combinational circuit (When TOL of TAUB0CH06 is 0)												
1	1	Inverted output from the combinational circuit (When TOL of TAUB0CH06 is 1)												
Other than the above		Setting is prohibited.												
19 18	PIC0REG20119 PIC0REG20118	<p>Selects the A input signal of FN01 according to the setting of the TOL bit for TAUB0CH05.</p> <table border="1"> <thead> <tr> <th>PIC0REG20119</th> <th>PIC0REG20118</th> <th>Input Signal</th> </tr> </thead> <tbody> <tr> <td>1</td> <td>0</td> <td>Output from the combinational circuit (When TOL of TAUB0CH05 is 0)</td> </tr> <tr> <td>1</td> <td>1</td> <td>Inverted output from the combinational circuit (When TOL of TAUB0CH05 is 1)</td> </tr> <tr> <td colspan="2">Other than the above</td> <td>Setting is prohibited.</td> </tr> </tbody> </table>	PIC0REG20119	PIC0REG20118	Input Signal	1	0	Output from the combinational circuit (When TOL of TAUB0CH05 is 0)	1	1	Inverted output from the combinational circuit (When TOL of TAUB0CH05 is 1)	Other than the above		Setting is prohibited.
PIC0REG20119	PIC0REG20118	Input Signal												
1	0	Output from the combinational circuit (When TOL of TAUB0CH05 is 0)												
1	1	Inverted output from the combinational circuit (When TOL of TAUB0CH05 is 1)												
Other than the above		Setting is prohibited.												
17 16	PIC0REG20117 PIC0REG20116	<p>Selects the A input signal of FN00 according to the setting of the TOL bit for TAUB0CH04.</p> <table border="1"> <thead> <tr> <th>PIC0REG20117</th> <th>PIC0REG20116</th> <th>Input Signal</th> </tr> </thead> <tbody> <tr> <td>1</td> <td>0</td> <td>Output from the combinational circuit (When TOL of TAUB0CH04 is 0)</td> </tr> <tr> <td>1</td> <td>1</td> <td>Inverted output from the combinational circuit (When TOL of TAUB0CH04 is 1)</td> </tr> <tr> <td colspan="2">Other than the above</td> <td>Setting is prohibited.</td> </tr> </tbody> </table>	PIC0REG20117	PIC0REG20116	Input Signal	1	0	Output from the combinational circuit (When TOL of TAUB0CH04 is 0)	1	1	Inverted output from the combinational circuit (When TOL of TAUB0CH04 is 1)	Other than the above		Setting is prohibited.
PIC0REG20117	PIC0REG20116	Input Signal												
1	0	Output from the combinational circuit (When TOL of TAUB0CH04 is 0)												
1	1	Inverted output from the combinational circuit (When TOL of TAUB0CH04 is 1)												
Other than the above		Setting is prohibited.												

Caution The bit might be defined to 0 by other timer connection functions. In that case, apply the bit definition of the corresponding timer connection function.

(3) Timer I/O Control Register 202 (PIC0REG202)

Access This register can be read/written in 32-bit units.

Address FF81 C0C8_H

Initial value 0000 0000_H

This register is initialized by any reset.

31	30	29	28	27	26	25	24
0	0	0	0	0	0	PIC0REG20225	PIC0REG20224
R	R	R	R	R	R	R/W	R/W
23	22	21	20	19	18	17	16
0	0	PIC0REG20221	PIC0REG20220	0	0	PIC0REG20217	PIC0REG20216
R	R	R/W	R/W	R	R	R/W	R/W
15	14	13	12	11	10	9	8
0	0	0	0	0	0	0	0
R	R	R	R	R	R	R	R
7	6	5	4	3	2	1	0
0	0	0	0	0	0	0	0
R	R	R	R	R	R	R	R

Table 24-13 PIC0REG202 Contents

Bit Position	Bit Name	Function									
25 24	PIC0REG20225 PIC0REG20224	Selects the TIN input signal of TAUB0CH14. <table border="1"> <thead> <tr> <th>PIC0REG20225</th> <th>PIC0REG20224</th> <th>Input Signal</th> </tr> </thead> <tbody> <tr> <td>1</td> <td>0</td> <td>Signal selected with PIC0REG20018 bit. (TOUT of TAUB0CH02)</td> </tr> <tr> <td colspan="2">Other than the above</td> <td>Setting is prohibited.</td> </tr> </tbody> </table>	PIC0REG20225	PIC0REG20224	Input Signal	1	0	Signal selected with PIC0REG20018 bit. (TOUT of TAUB0CH02)	Other than the above		Setting is prohibited.
PIC0REG20225	PIC0REG20224	Input Signal									
1	0	Signal selected with PIC0REG20018 bit. (TOUT of TAUB0CH02)									
Other than the above		Setting is prohibited.									
21 20	PIC0REG20221 PIC0REG20220	Selects the TIN input signal of TAUB0CH12. <table border="1"> <thead> <tr> <th>PIC0REG20221</th> <th>PIC0REG20220</th> <th>Input Signal</th> </tr> </thead> <tbody> <tr> <td>1</td> <td>0</td> <td>Signal selected with PIC0REG20018 bit. (TOUT of TAUB0CH02)</td> </tr> <tr> <td colspan="2">Other than the above</td> <td>Setting is prohibited.</td> </tr> </tbody> </table>	PIC0REG20221	PIC0REG20220	Input Signal	1	0	Signal selected with PIC0REG20018 bit. (TOUT of TAUB0CH02)	Other than the above		Setting is prohibited.
PIC0REG20221	PIC0REG20220	Input Signal									
1	0	Signal selected with PIC0REG20018 bit. (TOUT of TAUB0CH02)									
Other than the above		Setting is prohibited.									
17 16	PIC0REG20217 PIC0REG20216	Selects the TIN input signal of TAUB0CH10. <table border="1"> <thead> <tr> <th>PIC0REG20217</th> <th>PIC0REG20216</th> <th>Input Signal</th> </tr> </thead> <tbody> <tr> <td>1</td> <td>0</td> <td>Signal selected with PIC0REG20018 bit. (TOUT of TAUB0CH02)</td> </tr> <tr> <td colspan="2">Other than the above</td> <td>Setting is prohibited.</td> </tr> </tbody> </table>	PIC0REG20217	PIC0REG20216	Input Signal	1	0	Signal selected with PIC0REG20018 bit. (TOUT of TAUB0CH02)	Other than the above		Setting is prohibited.
PIC0REG20217	PIC0REG20216	Input Signal									
1	0	Signal selected with PIC0REG20018 bit. (TOUT of TAUB0CH02)									
Other than the above		Setting is prohibited.									

Caution The bit might be defined to 0 by other timer connection functions. In that case, apply the bit definition of the corresponding PIC connection function.

(4) Timer I/O Control Register 203 (PIC0REG203)

The PIC0REG203 register selects the logical operation.

Access This register can be read/written in 32-bit units.

Address FF81 C0CC_H

Initial value 0000 0000_H

This register is initialized by any reset.

31	30	29	28	27	26	25	24
0	0	0	0	0	0	0	0
R	R	R	R	R	R	R	R
23	22	21	20	19	18	17	16
0	PIC0REG20322	PIC0REG20321	PIC0REG20320	0	PIC0REG20318	PIC0REG20317	PIC0REG20316
R	R/W	R/W	R/W	R	R/W	R/W	R/W
15	14	13	12	11	10	9	8
0	PIC0REG20314	PIC0REG20313	PIC0REG20312	0	PIC0REG20310	PIC0REG20309	PIC0REG20308
R	R/W	R/W	R/W	R	R/W	R/W	R/W
7	6	5	4	3	2	1	0
0	PIC0REG20306	PIC0REG20305	PIC0REG20304	0	PIC0REG20302	PIC0REG20301	PIC0REG20300
R	R/W	R/W	R/W	R	R/W	R/W	R/W

Table 24-14 PIC0REG203 Contents (1/2)

Bit Position	Bit Name	Function																
22 21 20	PIC0REG20322 PIC0REG20321 PIC0REG20320	<p>Selects a logical operation to be performed on input signals A and B according to the setting of the TOL bit of TAUB0CH09.</p> <table border="1"> <thead> <tr> <th>PIC0REG20322</th><th>PIC0REG20321</th><th>PIC0REG20320</th><th>Input Signal</th></tr> </thead> <tbody> <tr> <td>1</td><td>0</td><td>0</td><td>A and B (When TOL of TAUB0CH09 is 0)</td></tr> <tr> <td>1</td><td>0</td><td>1</td><td>A or B (When TOL of TAUB0CH09 is 1)</td></tr> <tr> <td colspan="3">Other than the above</td><td>Setting is prohibited.</td></tr> </tbody> </table>	PIC0REG20322	PIC0REG20321	PIC0REG20320	Input Signal	1	0	0	A and B (When TOL of TAUB0CH09 is 0)	1	0	1	A or B (When TOL of TAUB0CH09 is 1)	Other than the above			Setting is prohibited.
PIC0REG20322	PIC0REG20321	PIC0REG20320	Input Signal															
1	0	0	A and B (When TOL of TAUB0CH09 is 0)															
1	0	1	A or B (When TOL of TAUB0CH09 is 1)															
Other than the above			Setting is prohibited.															
18 17 16	PIC0REG20318 PIC0REG20317 PIC0REG20316	<p>Selects a logical operation to be performed on input signals A and B according to the setting of the TOL bit of TAUB0CH08.</p> <table border="1"> <thead> <tr> <th>PIC0REG20318</th><th>PIC0REG20317</th><th>PIC0REG20316</th><th>Input Signal</th></tr> </thead> <tbody> <tr> <td>1</td><td>0</td><td>0</td><td>A and B (When TOL of TAUB0CH08 is 0)</td></tr> <tr> <td>1</td><td>0</td><td>1</td><td>A or B (When TOL of TAUB0CH08 is 1)</td></tr> <tr> <td colspan="3">Other than the above</td><td>Setting is prohibited.</td></tr> </tbody> </table>	PIC0REG20318	PIC0REG20317	PIC0REG20316	Input Signal	1	0	0	A and B (When TOL of TAUB0CH08 is 0)	1	0	1	A or B (When TOL of TAUB0CH08 is 1)	Other than the above			Setting is prohibited.
PIC0REG20318	PIC0REG20317	PIC0REG20316	Input Signal															
1	0	0	A and B (When TOL of TAUB0CH08 is 0)															
1	0	1	A or B (When TOL of TAUB0CH08 is 1)															
Other than the above			Setting is prohibited.															

Table 24-14 PIC0REG203 Contents (2/2)

Bit Position	Bit Name	Function																
14 13 12	PIC0REG20314 PIC0REG20313 PIC0REG20312	<p>Selects a logical operation to be performed on input signals A and B according to the setting of the TOL bit of TAUB0CH07.</p> <table border="1"> <thead> <tr> <th>PIC0REG 20314</th> <th>PIC0REG 20313</th> <th>PIC0REG 20312</th> <th>Input Signal</th> </tr> </thead> <tbody> <tr> <td>1</td> <td>0</td> <td>0</td> <td>A and B (When TOL of TAUB0CH07 is 0)</td> </tr> <tr> <td>1</td> <td>0</td> <td>1</td> <td>A or B (When TOL of TAUB0CH07 is 1)</td> </tr> <tr> <td colspan="3">Other than the above</td> <td>Setting is prohibited.</td> </tr> </tbody> </table>	PIC0REG 20314	PIC0REG 20313	PIC0REG 20312	Input Signal	1	0	0	A and B (When TOL of TAUB0CH07 is 0)	1	0	1	A or B (When TOL of TAUB0CH07 is 1)	Other than the above			Setting is prohibited.
PIC0REG 20314	PIC0REG 20313	PIC0REG 20312	Input Signal															
1	0	0	A and B (When TOL of TAUB0CH07 is 0)															
1	0	1	A or B (When TOL of TAUB0CH07 is 1)															
Other than the above			Setting is prohibited.															
10 9 8	PIC0REG20310 PIC0REG20309 PIC0REG20308	<p>Selects a logical operation to be performed on input signals A and B according to the setting of the TOL bit of TAUB0CH06.</p> <table border="1"> <thead> <tr> <th>PIC0REG 20310</th> <th>PIC0REG 20309</th> <th>PIC0REG 20308</th> <th>Input Signal</th> </tr> </thead> <tbody> <tr> <td>1</td> <td>0</td> <td>0</td> <td>A and B (When TOL of TAUB0CH06 is 0)</td> </tr> <tr> <td>1</td> <td>0</td> <td>1</td> <td>A or B (When TOL of TAUB0CH06 is 1)</td> </tr> <tr> <td colspan="3">Other than the above</td> <td>Setting is prohibited.</td> </tr> </tbody> </table>	PIC0REG 20310	PIC0REG 20309	PIC0REG 20308	Input Signal	1	0	0	A and B (When TOL of TAUB0CH06 is 0)	1	0	1	A or B (When TOL of TAUB0CH06 is 1)	Other than the above			Setting is prohibited.
PIC0REG 20310	PIC0REG 20309	PIC0REG 20308	Input Signal															
1	0	0	A and B (When TOL of TAUB0CH06 is 0)															
1	0	1	A or B (When TOL of TAUB0CH06 is 1)															
Other than the above			Setting is prohibited.															
6 5 4	PIC0REG20306 PIC0REG20305 PIC0REG20304	<p>Selects a logical operation to be performed on input signals A and B according to the setting of the TOL bit of TAUB0CH05.</p> <table border="1"> <thead> <tr> <th>PIC0REG 20306</th> <th>PIC0REG 20305</th> <th>PIC0REG 20304</th> <th>Input Signal</th> </tr> </thead> <tbody> <tr> <td>1</td> <td>0</td> <td>0</td> <td>A and B (When TOL of TAUB0CH05 is 0)</td> </tr> <tr> <td>1</td> <td>0</td> <td>1</td> <td>A or B (When TOL of TAUB0CH05 is 1)</td> </tr> <tr> <td colspan="3">Other than the above</td> <td>Setting is prohibited.</td> </tr> </tbody> </table>	PIC0REG 20306	PIC0REG 20305	PIC0REG 20304	Input Signal	1	0	0	A and B (When TOL of TAUB0CH05 is 0)	1	0	1	A or B (When TOL of TAUB0CH05 is 1)	Other than the above			Setting is prohibited.
PIC0REG 20306	PIC0REG 20305	PIC0REG 20304	Input Signal															
1	0	0	A and B (When TOL of TAUB0CH05 is 0)															
1	0	1	A or B (When TOL of TAUB0CH05 is 1)															
Other than the above			Setting is prohibited.															
2 1 0	PIC0REG20302 PIC0REG20301 PIC0REG20300	<p>Selects a logical operation to be performed on input signals A and B according to the setting of the TOL bit of TAUB0CH04.</p> <table border="1"> <thead> <tr> <th>PIC0REG 20302</th> <th>PIC0REG 20301</th> <th>PIC0REG 20300</th> <th>Input Signal</th> </tr> </thead> <tbody> <tr> <td>1</td> <td>0</td> <td>0</td> <td>A and B (When TOL of TAUB0CH04 is 0)</td> </tr> <tr> <td>1</td> <td>0</td> <td>1</td> <td>A or B (When TOL of TAUB0CH04 is 1)</td> </tr> <tr> <td colspan="3">Other than the above</td> <td>Setting is prohibited.</td> </tr> </tbody> </table>	PIC0REG 20302	PIC0REG 20301	PIC0REG 20300	Input Signal	1	0	0	A and B (When TOL of TAUB0CH04 is 0)	1	0	1	A or B (When TOL of TAUB0CH04 is 1)	Other than the above			Setting is prohibited.
PIC0REG 20302	PIC0REG 20301	PIC0REG 20300	Input Signal															
1	0	0	A and B (When TOL of TAUB0CH04 is 0)															
1	0	1	A or B (When TOL of TAUB0CH04 is 1)															
Other than the above			Setting is prohibited.															

Caution The bit might be defined to 0 by other timer connection functions. In that case, apply the bit definition of the corresponding PIC connection function.

(5) Hi-Z Output Control Register 0 (PIC0HIZCEN0)

PIC0HIZCEN0 selects the input signal to control Hi-Z output.

Access This register can be read/written in 8-bit units.

Address FF81 C080_H

Initial value 00_H

This register is initialized by any reset.

7	6	5	4	3	2	1	0
0	PIC0HIZ CEN06	PIC0HIZ CEN05	0	0	0	0	PIC0HIZ CEN00
R	R/W	R/W	R	R	R	R	R/W

Table 24-15 PIC0HIZCEN0 Contents

Bit Position	Bit Name	Function
6	PIC0HIZCEN06	Enables or disables Hi-Z output control with the INTADCA0TERR interrupt signal. 0: Disable 1: Enable
5	PIC0HIZCEN05	Enables or disables Hi-Z output control with the ERROROUT signal. 0: Disable 1: Enable
0	PIC0HIZCEN00	Enables or disables Hi-Z output control with the ESO0 pin input. 0: Disable 1: Enable

Caution The bit might be defined to 0 by other timer connection functions. In that case, apply the bit definition of the corresponding timer connection function.

24.4.3.4 Example of Operation

This function is achieved by combining the following TAUB functions.

- Triangle wave PWM output function with dead time
- One-shot pulse output function

The following functions of the PIC are used to generate the variable dead time range pulses for positive and negative phases to be inserted in the variable dead time range.

- Combinational circuit (PFN001, PFN023, and PFN045)

In addition, the following functions of the PIC are used to synthesize the triangle wave PWM output waveform and the variable dead time range pulses to be inserted in the variable dead time range.

- Logical operation circuit (FN0i) (i = 0 to 5)

The high accuracy triangle wave PWM output function with the dead time is actually implemented by assigning the PWM output obtained by the above functions to the U, V, and W phases, which allows independent dead time setting to the PWM output of each phase. Since the operation of the three phases is identical except for the channel assigned, only the operation of the U phase is explained below.

(1) Triangle Wave PWM Output Function with Dead Time

CH02, CH04, and CH05 are combined to allow the triangle wave PWM with the dead time to be output from TOUT04 and TOUT05.

(2) One-Shot Pulse Output Function

CH10 and CH11 are combined to allow the pulse of the width set in CDR11 to be output as TOUT11 with a delay amount set in CDR10 behind the effective edge of TIN10 (TOUT02) of CH10.

This pulse (TOUT11) is used as the variable dead time range pulse that is used in the range where duty cycle is close to 100% or 0%.

Caution Set each CDR for the one-shot pulse output function so that the following condition is satisfied.

$$\text{CDR05} \geq (\text{CDR10} + \text{CDR11})$$

If the condition above is not satisfied, the output waveform may be influenced. To minimize the influence, satisfy the condition above, and also fix the value of CDR11 to 0000_H until the variable dead time range pulse is required.

Set the both edges to be detected of TIN10 (TOUT02) as effective, and set TAUB0TOL11 to 1 (active low).

Set the same operating clock for all the TAUB0 channels that are used for the triangle wave PWM output function with the dead time and one-shot pulse output function.

For details on TAUB functions, refer to Section 13, Timer Array Unit B (TAUB).

(3) U Phase Combinational Circuit (PFN001)

The U phase combination circuit generates variable dead time range pulses (FN00 A and FN01 A) that are used to insert the dead time pulse generated by the one-shot pulse output function into the triangle wave PWM generated by the triangle wave PWM output function with the dead time.

Table 24-16 shows the relation between the inputs (UIN and U2) and the outputs (UO1 and UO2) of the combinational circuit.

Table 24-16 Inputs and Outputs of Combinational Circuit PFN001 (U Phase and UB Phase)

UO1 output (U phase variable dead time range pulse*)

UIN (TOUT02)	U2 (TOUT11)	UO1	
		PIC0REG20117 and PIC0REG20116 = 10B U Phase Output: Active High (TAUB0TOL04 = 0)	PIC0REG20117 and PIC0REG20116 = 11B U Phase Output: Active Low (TAUB0TOL04 = 1)
0	0	1	0
0	1	1	0
1	0	0	1
1	1	1	0

UO2 output (UB phase variable dead time range pulse*)

UIN (TOUT02)	U2 (TOUT11)	UO2	
		PIC0REG20119 and PIC0REG20118 = 10B UB Phase Output: Active High (TAUB0TOL05 = 0)	PIC0REG20119 and PIC0REG20118 = 11B UB Phase Output: Active Low (TAUB0TOL05 = 1)
0	0	0	1
0	1	1	0
1	0	1	0
1	1	1	0

Note * Description of variable dead time range pulse

Variable dead time range pulses are the pseudo pulses that are inserted into the PWM output provided by the triangle wave PWM output function with the dead time of TAUB and that are modeled on the dead time pulses that are generated in the range where duty cycle is close to 100% or 0% in PWM output in HT-PWM mode of TSG2.

Note: Setting of PIC0REG201k (k = 16 to 19) depends on the active level of the U or UB phase output of the triangle wave PWM generated by the triangle wave PWM output function with the dead time.

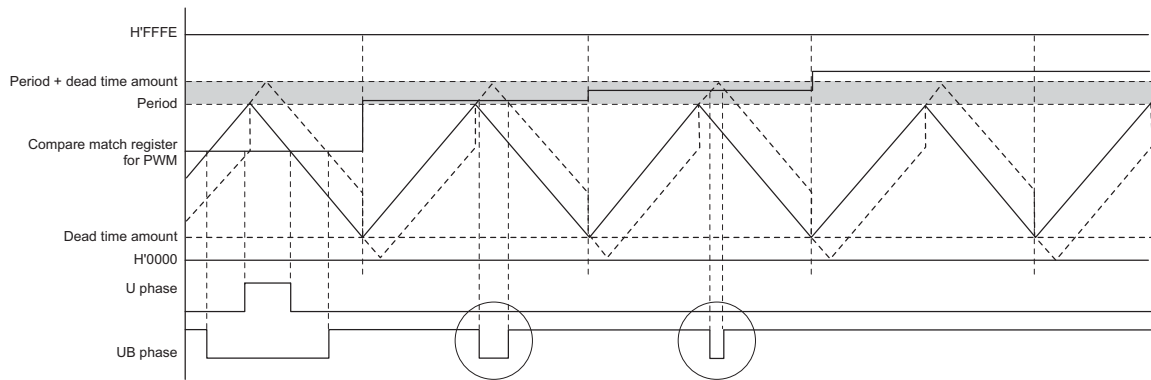

Figure 24-7 Dead Time Output Timing in HT-PWM Mode of TSG2

When the duty cycle of U phase PWM output changes to 0% in HT-PWM mode of TSG2, a compare match that changes the U phase pulse does not occur if a compare match value is set within the shaded range (variable dead time range). However, in the same condition, a compare match that changes the UB phase pulse occurs. Accordingly, only the UB phase pulses are generated.

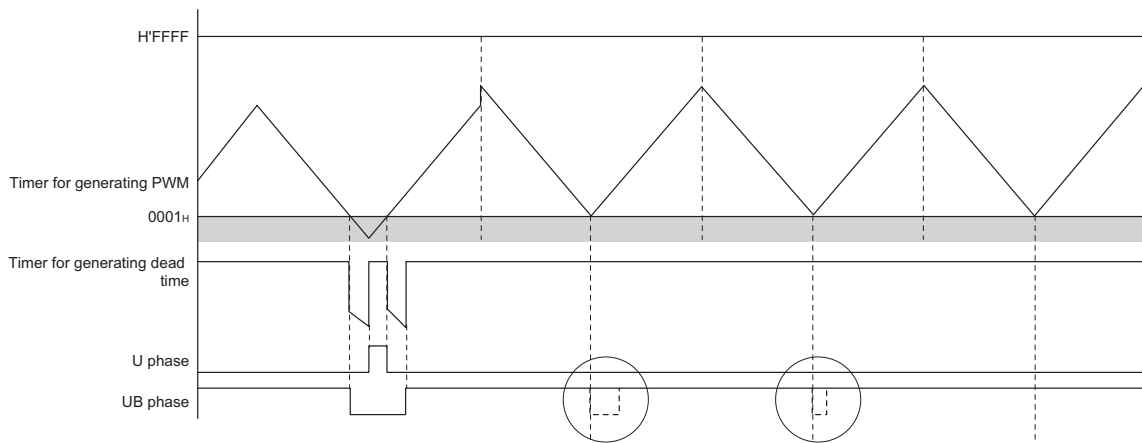

Figure 24-8 Dead Time Output Timing Generated by Triangle Wave PWM Output Function with Dead Time of TAUB

On the other hand, when the duty cycle of U phase is changed to 0% in PWM output by the triangle wave PWM output function with the dead time of TAUB, the UB phase pulses, which can be output by TSG2, cannot be output.

This function uses the timer to generate the pulses to be used in the variable dead time range, and uses the combinational circuit to generate the pulses to be inserted into U or UB phase appropriately according to the conditions in Table 24-16, Inputs and Outputs of Combinational Circuit PFN001 (U Phase and UB Phase).

(4) Logical Operation Circuit (FN0i) (i = 0, 1)

The logical operation circuit synthesizes the triangle wave PWM output (TOUT04 and TOUT05) from the triangle wave PWM output function with the dead time and the outputs UO1 and UO2 from the combinational circuit PFN001 to generate PWM with variable dead time range pulses inserted.

The synthesizing logic of the logical operation circuit is selected with PIC0REG203k (k = 00 to 06).

Set the synthesizing logic for this function as shown in Table 24-17, Setting of Logical Operation Circuit (FN0i, i = 0, 1) and TAUB0010 and TAUB0011 Outputs. The pins TAUB0010 and TAUB0011 output the signals synthesized according to the specified logic.

Table 24-17 Setting of Logical Operation Circuit (FN0i, i = 0, 1) and TAUB0010 and TAUB0011 Outputs

U phase output (TOUT04)

Active Level	PIC0REG20302 to PIC0REG20300	TAUB0010 Pin Output Waveform
Active high (TAUB0TOL04 = 0)	100 _B	AND operation between FN00 B (TOUT04) and FN00 A (UO1)
Active low (TAUB0TOL04 = 1)	101 _B	OR operation between FN00 B (TOUT04) and FN00 A (UO1)

UB phase output (TOUT05)

Active Level	PIC0REG20306 to PIC0REG20304	TAUB0011 Pin Output Waveform
Active high (TAUB0TOL05 = 0)	100 _B	AND operation between FN01 B (TOUT05) and FN01 A (UO2)
Active low (TAUB0TOL05 = 1)	101 _B	OR operation between FN01 B (TOUT05) and FN01 A (UO2)

With the logical operations above, TAUB can perform the variable dead time control for securing accurate output when the duty cycle is close to 0% or 100%, thus enabling output of triangle wave PWM more accurate than that provided by the triangle wave PWM output function with the dead time of the TAUB function.

The values to be set for V, VB, W, and WB phases are the same as those for U phase, although the channels and the register bits are different as shown in Figure 24-6, Block Diagram.

The PIC provides the connection for inserting the pulses generated by the one-shot pulse output function into the PWM signal generated by the triangle wave PWM output function with the dead time through use of the combinational circuit and the logical operation circuit, which are provided as the PIC functions.

Figures in the following pages show the timing charts of the high accuracy triangle wave PWM output function with the dead time.

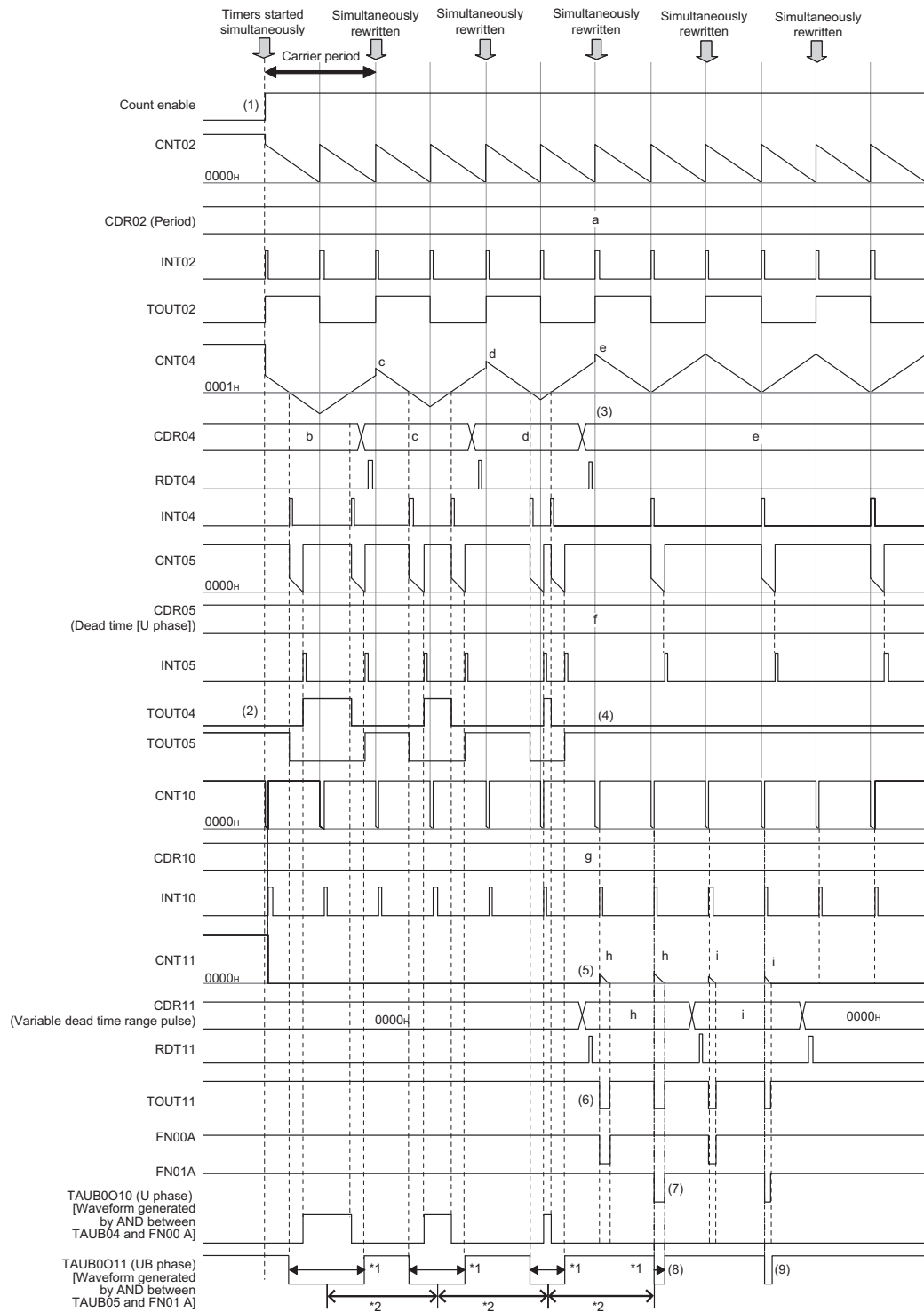

Figure 24-9 High Accuracy Triangle Wave PWM (U Phase Duty Cycle = 0%; UB Phase Duty Cycle = 100%) Output Example with Dead Time (When TOL4 = 0 (Active High) and TOL5 = 0 (Active High))

The following describes the operation example shown in Figure 24-19, where duty cycles of U-phase and UB-phase outputs change to 0% and 100%, respectively, using the timer configuration for U phase PWM output. The output of the triangle wave PWM output function with the dead time is active high.

1. The triangle wave PWM output function with the dead time using CH02, CH04, and CH05 of TAUB0 starts triggered by the start of timer operation.
2. PWM waveforms with the dead time are output from TOUT04 and TOUT05 by the triangle wave PWM output function with the dead time.
3. A 0% duty cycle value is set in CDR04 for U phase output.
4. The setting described in (3) sets the TOUT04 output to the inactive level and the TOUT05 output to the active level. Note that, however, the variable dead time range pulse is not output by this operation.
5. To generate the variable dead time range pulse, a value for the variable dead time range pulse width is set in CDR11 when a 0% duty cycle value for U phase output is set in step (3).
In this example, the value of CDR11 is fixed to 0000_H until the entry into the variable dead time range to minimize the influence on the output PWM.
6. The variable dead time range pulse of the width set in CDR11 is output at the edge of TOUT02 after the elapse of the delay time set in CDR10.
7. The pulse that is output in step (6) is converted to the variable dead time range pulse for U phase (FN00A) or UB phase (FN01A) by the combinational circuit PFN001.
8. The pulses generated in step (7) are synthesized with the TOUT04 and TOUT05 output pulses in the logical operation circuits (FN00 and FN01) and are output from TAUB0O10 (U phase output) and TAUB0O11 (UB phase output).
9. After step (8), variable dead time range pulse of a desired width can be inserted by changing the set values of CDR11, which specifies the variable dead time range pulse width.

Note 1. Since the variable dead time range pulses are sawtooth waves, they expand and contract on one side, unlike the triangle wave pulses, which expand and contract on both sides.

Note 2. Since one-side expansion and contraction applies to the variable dead time range pulses, a one-phase PWM output period in the variable dead time range is longer by half the width of an inserted variable dead time range pulse.

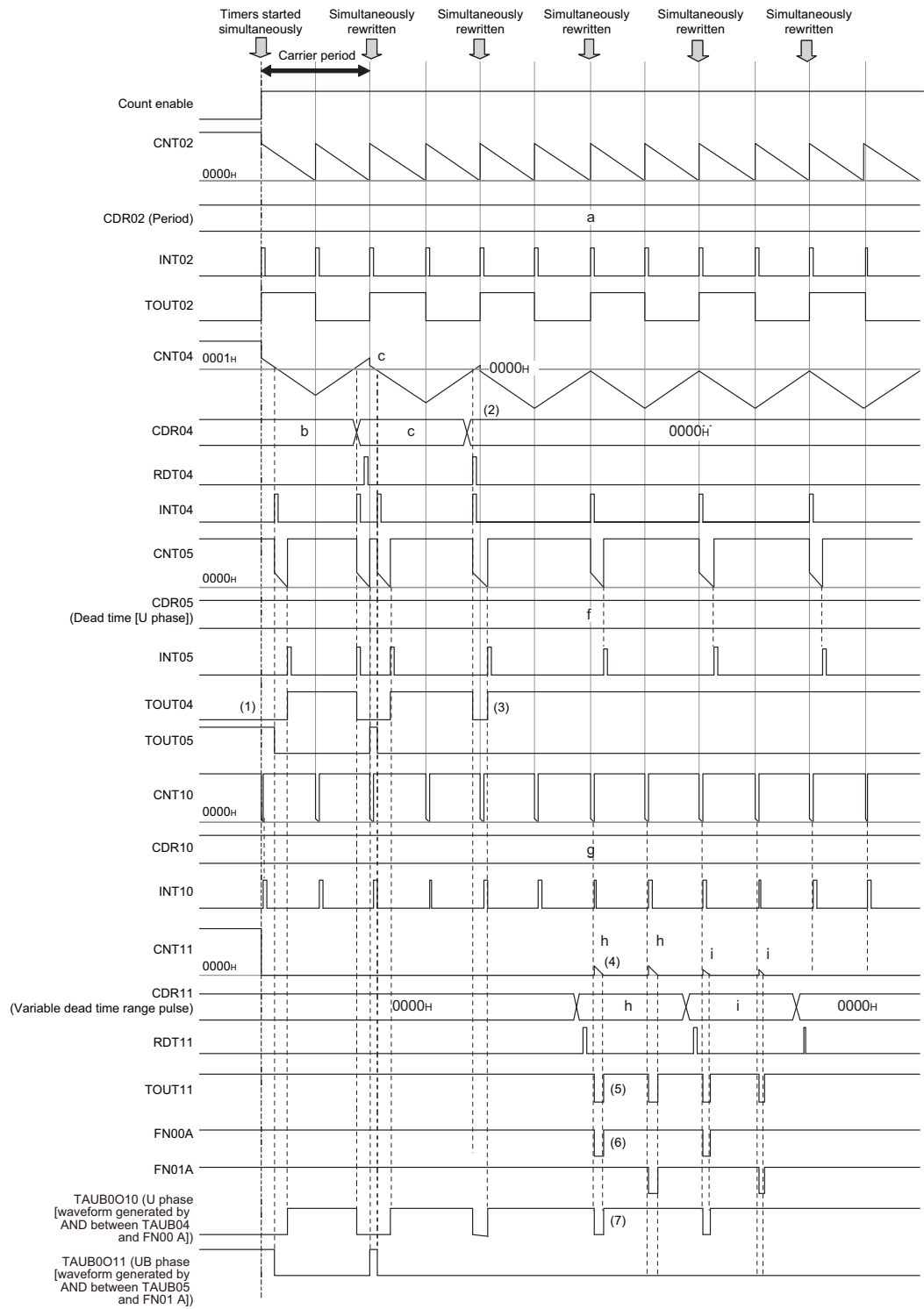

Figure 24-10 High Accuracy Triangle Wave PWM (U Phase Duty Cycle: 100%; UB Phase Duty Cycle: 0%) Output Example with Dead Time (When TOL4 = 0 (Active High) and TOL5 = 0 (Active High))

The following describes the operation example shown in Figure 24-19, where duty cycles of U-phase and UB-phase outputs change to 100% and 0%, respectively, using the timer configuration for U phase PWM output. The output of the triangle wave PWM output function with the dead time is active high.

1. Timer operation from the timer start to triangle wave PWM output with the dead time is the same as the operation shown in Figure 24-16.
2. A 100% duty cycle value (0000_H) is set in CDR04 for U phase output.
3. The setting described in (2) sets the TOUT04 output to the active level and the TOUT05 output to the inactive level. Note that, however, the variable dead time range pulse is not output by this operation.
4. To generate the variable dead time range pulse, a value for the variable dead time range pulse width is set in CDR11 one period after setting 100% duty cycle for U phase output (step (2)).
In this example, the value of CDR11 is fixed to 0000_H until the entry into the variable dead time range to minimize the influence on the output PWM.
5. The variable dead time range pulse of the width set in CDR11 is output at the edge of TOUT02 after the elapse of the delay time set in CDR10.
6. The pulse that is output in step (5) is converted to the variable dead time range pulse for U phase (FN00A) or UB phase (FN01A) by the combinational circuit PFN001.
7. The pulses generated in step (6) are synthesized with the TOUT04 and TOUT05 output pulses in the logical operation circuits (FN00 and FN01) and are output from TAUB0010 (U phase output) and TAUB0011 (UB phase output).

Note As shown in Figure 24-11, An Example of Variable Dead Time Range Pulse Giving Influence on Triangle Wave PWM Output with Dead Time, if a value is set for the variable dead time range pulse width in CDR11 at the same time as a 100% duty cycle value is set for U phase output in CDR04, the variable dead time range pulse affects the last PWM output from TOUT04 (indicated by (1)) by the amount of time indicated by (2), which is due to the functional specification.
To eliminate this influence, CDR11 must be set one period after setting CDR04.

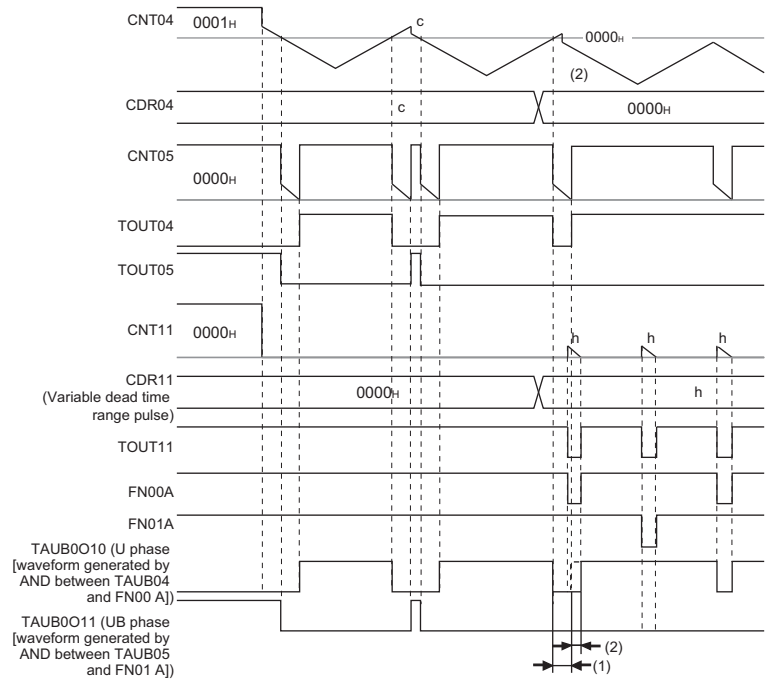

Figure 24-11 An Example of Variable Dead Time Range Pulse Giving Influence on Triangle Wave PWM Output with Dead Time

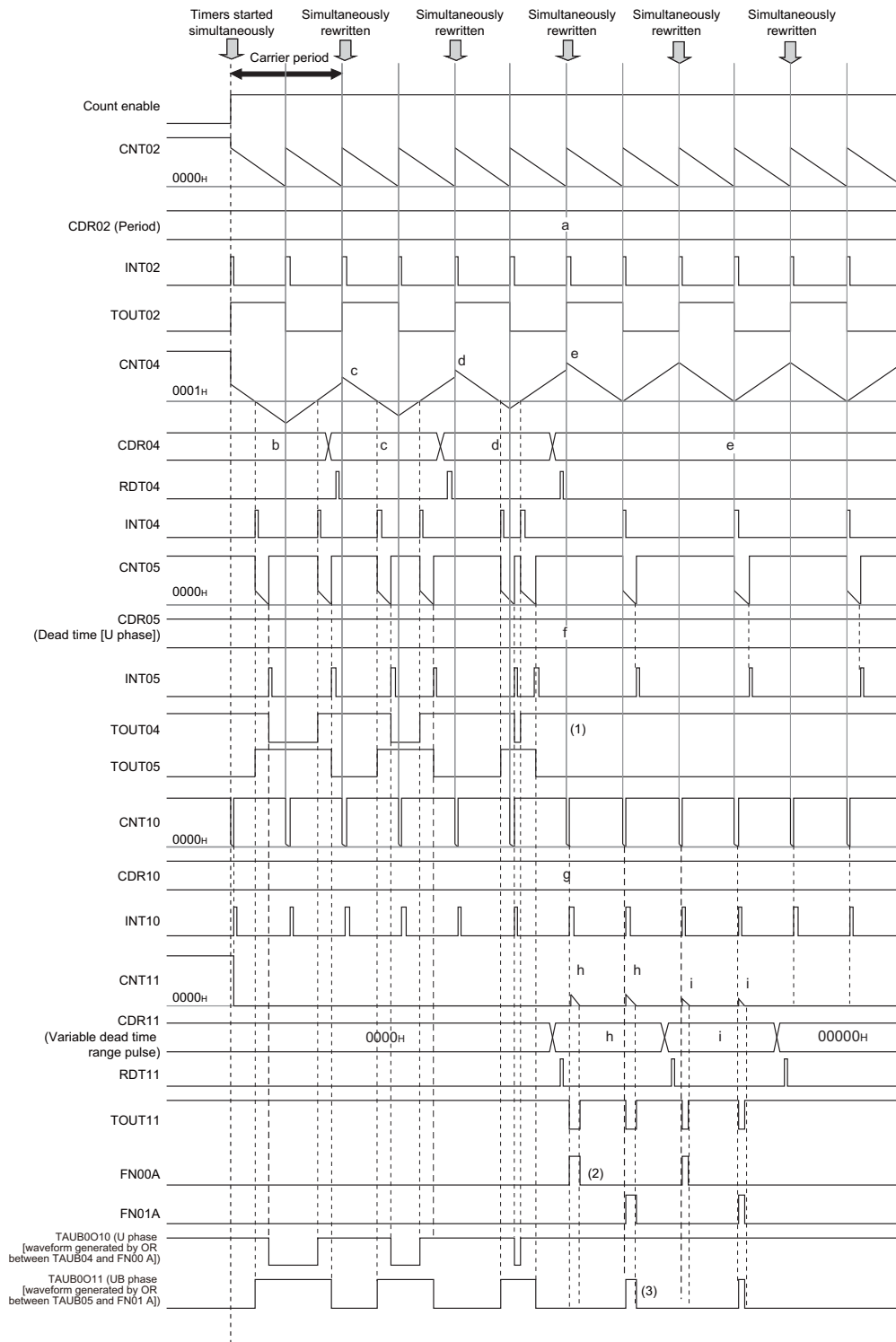

Figure 24-12 High Accuracy Triangle Wave PWM (U Phase Duty Cycle = 100%; UB Phase Duty Cycle = 0%) Output Example with Dead Time (When TOL4 = 1 (Active Low) and TOL5 = 1 (Active Low))

The following describes the operation example shown in Figure 24-12, High Accuracy Triangle Wave PWM (U Phase Duty Cycle = 100%; UB Phase Duty Cycle = 0%) Output Example with Dead Time (When TOL4 = 1 (Active Low) and TOL5 = 1 (Active Low)), where duty cycles of U-phase and UB-phase outputs change to 100% and 0%, respectively, using the timer configuration for U phase PWM output. The output of the triangle wave PWM output function with the dead time is active low.

1. Timer operation from the timer start to triangle wave PWM output with the dead time is the same as the operation shown in Figure 24-9, High Accuracy Triangle Wave PWM (U Phase Duty Cycle = 0%; UB Phase Duty Cycle = 100%) Output Example with Dead Time (When TOL4 = 0 (Active High) and TOL5 = 0 (Active High)). Note that, however, the PWM outputs from (Accordingly,) TOUT04 and TOUT05 are active low.
2. Accordingly, the combinational circuit setting (PIC0REG20116, PIC0REG20117 and PIC0REG20118, PIC0REG20119) should be made so that the active low output is selected (the same level as the PWM outputs). With this setting, variable dead time range pulses for active low are output as FN00A (for U phase) and FN01A (for UB phase).
3. Similarly, the logical operation circuit setting (PIC0REG20302 to PIC0REG20300 and PIC0REG20306 to PIC0REG20304) should be made so that active low output is selected (the same level as the PWM outputs). The pulses generated in step (2) are synthesized with the TOUT04 and TOUT05 output waveforms, and are output as PWM for active low from TAUB0010 (U phase output) and TAUB0011 (UB phase output).

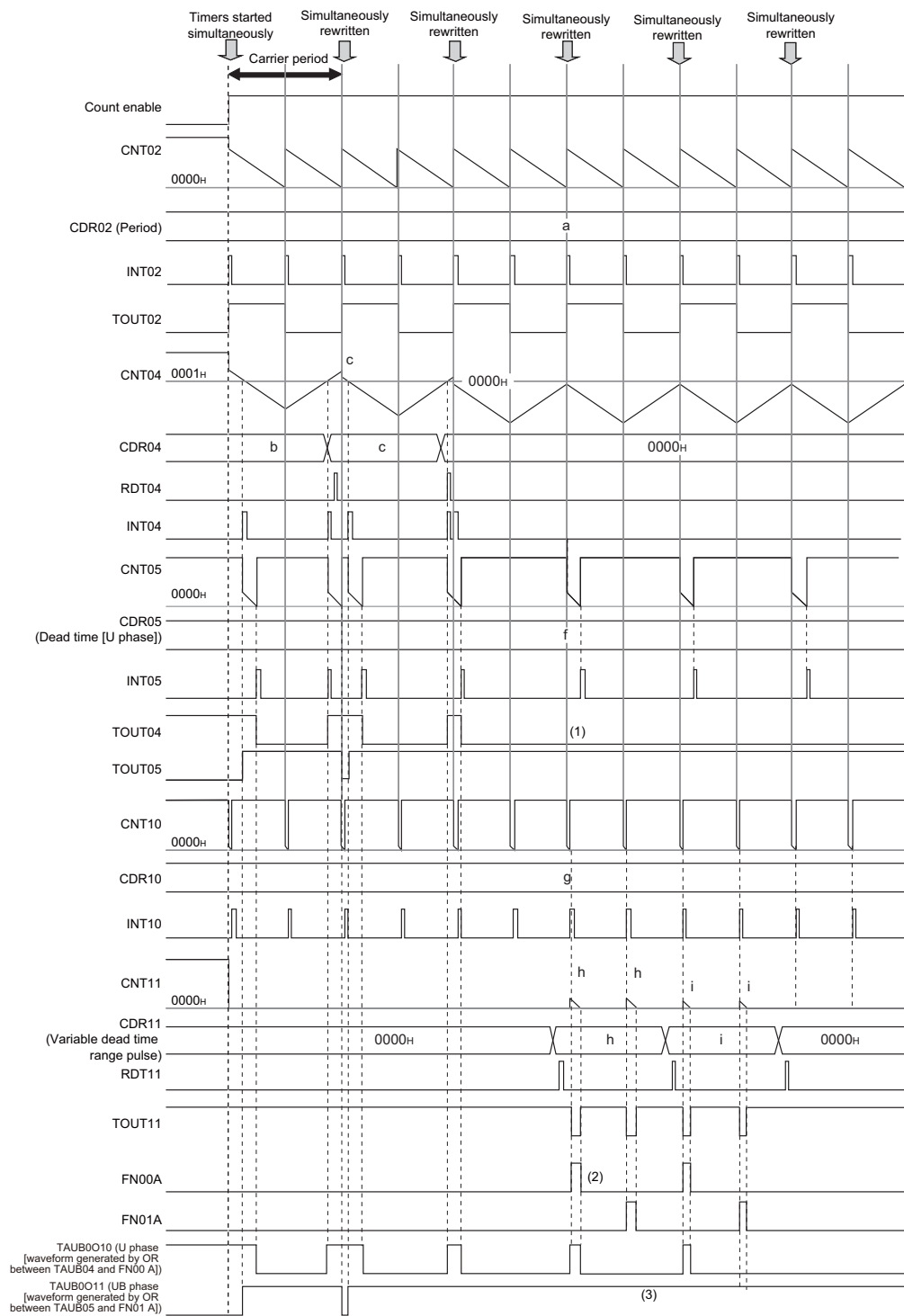

Figure 24-13 High Accuracy Triangle Wave PWM (U Phase Duty Cycle = 0%; UB Phase Duty Cycle = 100%) Output Example with Dead Time (When TOL4 = 0 (Active Low) and TOL5 = 0 (Active Low))

The following describes the operation example shown in Figure 24-13, High Accuracy Triangle Wave PWM (U Phase Duty Cycle = 0%; UB Phase Duty Cycle = 100%) Output Example with Dead Time (When TOL4 = 0 (Active Low) and TOL5 = 0 (Active Low)), where duty cycles of U-phase and UB-phase outputs change to 0% and 100%, respectively, using the timer configuration for U phase PWM output. The output of the triangle wave PWM output function with the dead time is active low.

1. Timer operation from the timer start to triangle wave PWM output with the dead time is the same as the operation shown in Figure 24-10, High Accuracy Triangle Wave PWM (U Phase Duty Cycle: 100%; UB Phase Duty Cycle: 0%) Output Example with Dead Time (When TOL4 = 0 (Active High) and TOL5 = 0 (Active High)). Note that, however, the PWM outputs are active low.
2. Accordingly, the combinational circuit setting (PIC0REG20116, PIC0REG20117 and PIC0REG20118, PIC0REG20119) should be made so that the active low output is selected (the same level as the PWM outputs). With this setting, variable dead time range pulses for active low are output as FN00A (for U phase) and FN01A (for UB phase).
3. Similarly, the logical operation circuit setting (PIC0REG20302 to PIC0REG20300 and PIC0REG20306 to PIC0REG20304) should be made so that active low output is selected (the same level as the PWM outputs). The pulses generated in step (2) are synthesized with the TOUT04 and TOUT05 output waveforms, and are output as PWM for active low from TAUB0010 (U phase output) and TAUB0011 (UB phase output).

Caution If a value is set for the variable dead time range pulse width in CDR11 at the same time as a 100% duty cycle value is set for U phase output in CDR04, the last PWM output from TOUT04 is affected due to the functional specification. To eliminate this influence, CDR11 must be set one period after setting CDR04.

For details, refer to Figure 24-11, An Example of Variable Dead Time Range Pulse Giving Influence on Triangle Wave PWM Output with Dead Time.

24.4.3.5 Operation Flow

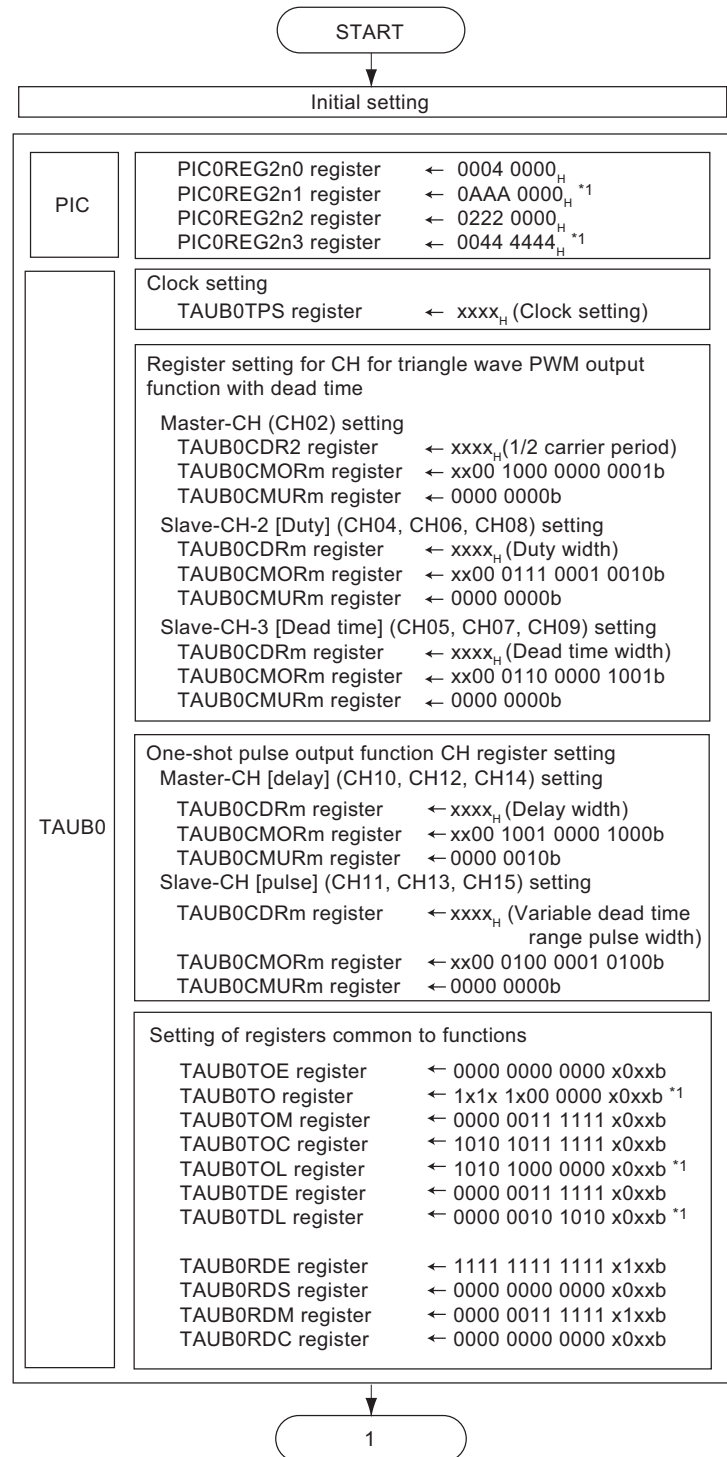

Figure 24-14 Setting Flow (Active High)

Note Change the set value depending on the active level of the PWM output.

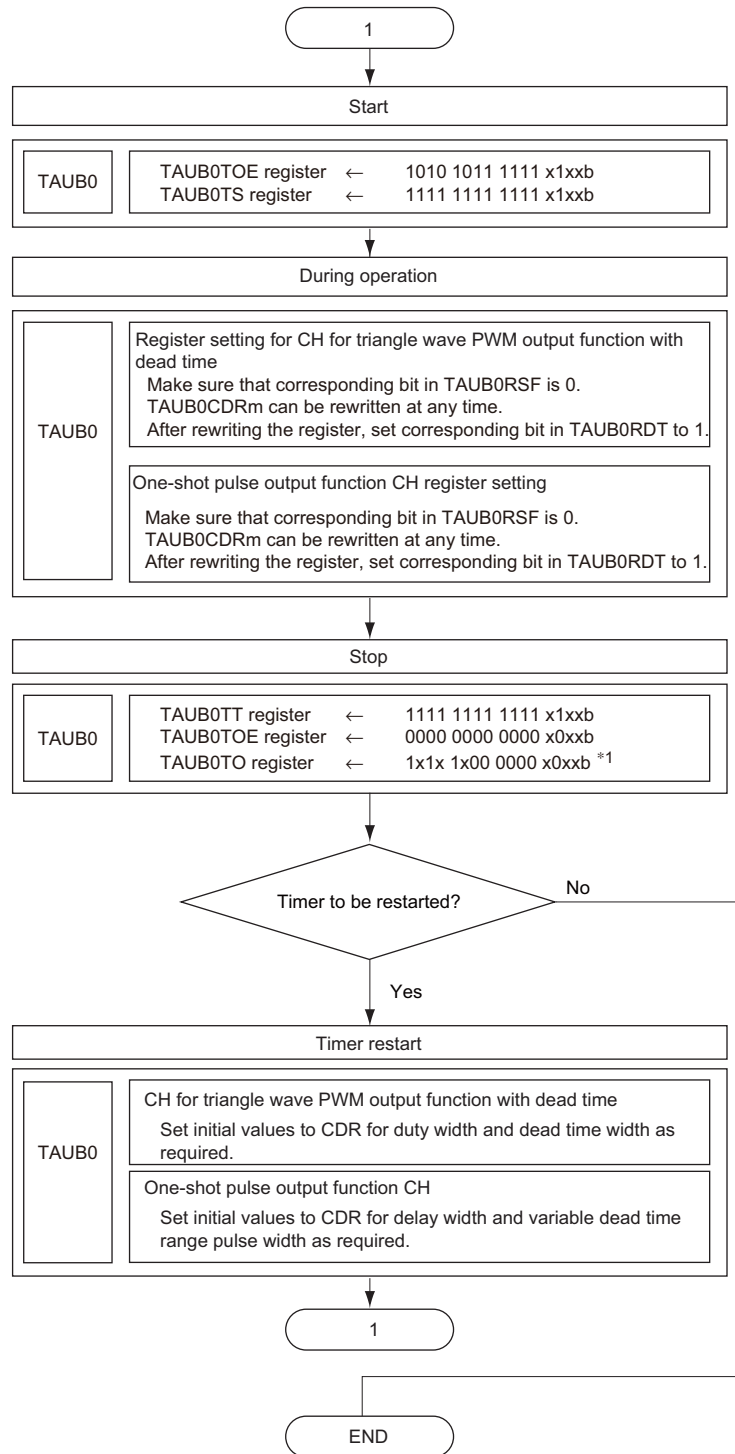

Figure 24-15 Setting Flow (Active High) (cont.)

Note Change the set value depending on the active level of the PWM output.

24.4.3.6 Register Setting Examples for Various Functions

Table 24-18 TAUB0 Setting (Active High)

Registers related to TAUB0 CH02 (Master-CH*1 for triangle wave PWM output function with dead time)

Function	Register	Bit Position	Bit Name	Set Value	Note
TAUB0	TAUB0 CMOR2	15, 14	CKS1 CKS0	Don't care ²	The operating clock is set.
		13, 12	CCS1 CCS0	0 0	
		11	MAS	1	
		10 to 8	STS2 STS1 STS0	0 0 0	
		7,6	COS1 COS0	0 0	
		5		0	
		4	MD4	0	1: Outputs INTn and toggles TOUTn at the start of operation.
		3	MD3	0	
		2	MD2	0	
		1	MD1	0	
		0	MD0	1	
			TAUB0 CMUR2	1, 0	TIS1 TIS0

Note 1. Master-CH and Slave-CH are the names defined with the TAUB triangle wave PWM output function with the dead time. For details, refer to Section 13, Timer Array Unit B (TAUB)

Note 2. The same operating clock should be set for Master-CH and Slave-CH.

Note In TAUB0CMORm of Master-CH for the triangle wave PWM output function with the dead time, only the CKS (operating clock select) bits and the MD0 bit can be set arbitrarily; the other control bits are fixed to the values specified above. For details, refer to Section 13, Timer Array Unit B (TAUB).

Set the MD0 bit to 1 to perform this PIC function.

Registers related to TAUB0 CH04, CH06, and CH08 (triangle wave PWM output function with dead time Slave-CH2*1) (m = 4, 6, and 8)

Function	Register	Bit Position	Bit Name	Set Value	Note
TAUB0	TAUB0 CMORm	15, 14	CKS1 CKS0	Don't care*2	The operating clock is set.
		13, 12	CCS1 CCS0	0 0	
		11	MAS	0	
		10 to 8	STS2 STS1 STS0	1 1 1	
		7, 6	COS1 COS0	0 0	
		5		0	
		4	MD4	1	
		3	MD3	0	
		2	MD2	0	
		1	MD1	1	
		0	MD0	0	
		TAUB0 CMURm	1, 0	TIS1 TIS0	

Registers related to TAUB0 CH05, CH07, and CH09 (triangle wave PWM output function with dead time Slave-CH3*1) (m = 5, 7, and 9)

Function	Register	Bit Position	Bit Name	Set Value	Note
TAUB0	TAUB0 CMORm	15, 14	CKS1 CKS0	Don't care*2	The operating clock is set.
		13, 12	CCS1 CCS0	0 0	
		11	MAS	0	
		10 to 8	STS2 STS1 STS0	1 1 0	
		7, 6	COS1 COS0	0 0	
		5		0	
		4	MD4	0	
		3	MD3	1	
		2	MD2	0	
		1	MD1	0	
		0	MD0	1	
		TAUB0 CMURm	1, 0	TIS1 TIS0	

Note 1. Master-CH and Slave-CH are the names defined with the TAUB triangle wave PWM output function with the dead time. For details, refer to Section 13, Timer Array Unit B (TAUB).

Note 2. The same operating clock should be set for Master-CH and Slave-CH.

Note In TAUB0CMORm for Slave-CH2 and Slave-CH3 for the triangle wave PWM output function with the dead time, only the CKS (operating clock select) bits can be set arbitrarily; the other control bits are fixed to the values specified above. For details, refer to Section 13, Timer Array Unit B (TAUB).

Registers related to TAUB0 CH10, CH12, and CH14 (One-shot pulse output function Master-CH*1) (m = 10, 12, and 14)

Function	Register	Bit Position	Bit Name	Set Value	Note	
TAUB0	TAUB0 CMORM	15, 14	CKS1 CKS0	Don't care ^{*2}	The operating clock is set.	
		13, 12	CCS1 CCS0	0 0		
		11	MAS	1		
		10 to 8	STS2 STS1 STS0	0 0 1		
		7, 6	COS1 COS0	0 0		
		5		0		
		4	MD4	0		
		3	MD3	1		
		2	MD2	0		
		1	MD1	0		
		0	MD0	0		
			TAUB0 CMURm	1, 0	TIS1 TIS0	1 0

Registers related to TAUB0 CH11, CH13, and CH15 (One-shot pulse output function Slave-CH*1) (m = 11, 13, and 15)

Function	Register	Bit Position	Bit Name	Set Value	Note	
TAUB0	TAUB0 CMORM	15, 14	CKS1 CKS0	Don't care ^{*2}	The operating clock is set.	
		13, 12	CCS1 CCS0	0 0		
		11	MAS	0		
		10 to 8	STS2 STS1 STS0	1 0 0		
		7, 6	COS1 COS0	0 0		
		5		0		
		4	MD4	1		
		3	MD3	0		
		2	MD2	1		
		1	MD1	0		
		0	MD0	0		
			TAUB0 CMURm	1, 0	TIS1 TIS0	0 0

- Note 1. Master-CH and Slave-CH are the names defined with the TAUB one-shot pulse output function. For details, refer to Section 13, Timer Array Unit B (TAUB).
2. The same operating clock should be set for Master-CH and Slave-CH. Set the same operating clock as the clock for Master-CH (CH02) for the triangle wave PWM output function with the dead time.

Note In TAUB0CMORM for the one-shot pulse output function, only the CKS (operating clock select) bits and the MD0 bit can be set arbitrarily; the other control bits are fixed to the values specified above. For details, refer to Section 13, Timer Array Unit B (TAUB).

Set the MD0 bit to 0 for this function.

Registers related to TAUB0 channels in common

Function	Register	Bit Position	Bit Name	Set Value	Note	
TAUB0	TAUB0TOE	15	TOE15	0 1	Timer operation is stopped. Timer operation is started.	
		14	TOE14	0		
		13	TOE13	0 1	Timer operation is stopped. Timer operation is started.	
		12	TOE12	0		
		11	TOE11	0 1	Timer operation is stopped. Timer operation is started.	
		10	TOE10	0		
		9 to 4	TOE09 to TOE04	0 1	Timer operation is stopped. Timer operation is started.	
		3	TOE03	Don't care		
		2	TOE02	0 1	Timer operation is stopped. Timer operation is started.	
		1, 0	TOE01 TOE00	Don't care		
	TAUB0TO	TAUB0TO	15	TO15	1*1	High level is output from the TOUT15 pin.
			14	TO14	Don't care	
			13	TO13	1*1	High level is output from the TOUT13 pin.
			12	TO12	Don't care	
			11	TO11	1*1	High level is output from the TOUT11 pin.
			10	TO10	Don't care	
			9 to 4	TO09 to TO04	0*1	Low level is output from the TOUT09 to TOUT04 pins.
			3	TO03	Don't care	
			2	TO02	0	Low level is output from the TOUT02 pin.
			1, 0	TO01 TO00	Don't care	
	TAUB0TOM	TAUB0TOM	15 to 10	TOM15 to TOM10	0	Independent operation mode
			9 to 4	TOM09 to TOM04	1	Synchronous operation mode
			3	TOM03	Don't care	
			2	TOM02	0	Independent operation mode
			1, 0	TOM01 TOM00	Don't care	
	TAUB0TOC	TAUB0TOC	15	TOC15	1	Set/reset mode
			14	TOC14	0	
			13	TOC13	1	Set/reset mode
			12	TOC12	0	
			11	TOC11	1	Set/reset mode
			10	TOC10	0	
			9 to 4	TOC09 to TOC04	1	Synchronous operation mode 2
			3	TOC03	Don't care	
			2	TOC02	0	Toggle mode
	1, 0	TOC01 TOC00	Don't care			

Note 1. Change the set value depending on the system used.

Registers related to TAUB0 channels in common (cont.)

Function	Register	Bit Position	Bit Name	Set Value	Note
TAUB0	TAUB0TOL	15	TOL15	1* ¹	Negative logic output (active low)
		14	TOL14	Don't care	
		13	TOL13	1* ¹	Negative logic output (active low)
		12	TOL14	Don't care	
		11	TOL11	1* ¹	Negative logic output (active low)
		10	TOL10	Don't care	
		9 to 4	TOL09 to TOL04	0* ¹	Positive logic output (active high)
		3	TOL03	Don't care	
		2	TOL02	0	Positive logic output (active high)
	1, 0	TOL01 TOL00	Don't care		
	TAUB0TDE	15 to 10	TDE15 to TDE10	0	Dead time control is disabled.
		9 to 4	TDE09 to TDE04	1	Dead time control is abled.
		3	TDE03	Don't care	
		2	TDE02	0	Dead time control is disabled.
		1, 0	TDE01 TDE00	Don't care	
	TAUB0TDL	15 to 10	TDL15 to TDL10	0	Invalid since dead time control is disabled.
		9	TDL09	1	Operates for negative phase of W phase.
		8	TDL08	0* ¹	Operates for positive phase of W phase.
		7	TDL07	1* ¹	Operates for negative phase of V phase.
		6	TDL06	0* ¹	Operates for positive phase of V phase.
		5	TDL05	1* ¹	Operates for negative phase of U phase.
		4	TDL04	0* ¹	Operates for positive phase of U phase.
		3	TDL03	Don't care	
	2	TDL02	0	Invalid since dead time control is disabled.	
	1, 0	TDL01 TDL00	Don't care		

Note 1. Change the set value depending on the system used.

Note 2. For dead time control, an even numbered CH and an odd numbered CH are used as a pair to output the positive and negative phase waveforms. For details, refer to Section 13, Timer Array Unit B (TAUB).

Registers related to TAUB0 channels in common (n = 0, 1) (cont.)

Function	Register	Bit Position	Bit Name	Set Value	Note
TAUB0	TAUB0RDE	15 to 4	RDE15 to RDE04	1	Simultaneous rewrite control is enabled.
		3	RDE03	Don't care	
		2	RDE02	1	Simultaneous rewrite control is enabled.
		1,0	RDE01 RDE00	Don't care	
	TAUB0RDS	15 to 4	RDS15 to RDS04	0	Simultaneous rewrite control through another upper CH is disabled.
		3	RDS03	Don't care	
		2	RDS02	0	Simultaneous rewrite control through another upper CH is disabled.
		1,0	RDS01 RDS00	Don't care	
	TAUB0RDM	15 to 10	RDM15 to RDM10	0	Simultaneous rewrite control is performed at the start of Master-CH.
		9 to 4	RDM09 to RDM04	1	Simultaneous rewrite control is performed at the start of Master-CH that operates at the triangle wave period.
		3	RDM03	Don't care	
		2	RDM02	1	Simultaneous rewrite control is performed at the start of Master-CH that operates at the triangle wave period.
		1,0	RDM01 RDM00	Don't care	
	TAUB0RDC	15 to 4	RDC15 to RDC04	0	Does not operate as simultaneous rewrite trigger generating CH.
		3	RDC03	Don't care	
		2	RDC02	0	Does not operate as simultaneous rewrite trigger generating CH.
		1,0	RDC01 RDC00	Don't care	

Table 24-19 PIC Setting (Active High)

Function	Register	Bit Position	Bit Name	Set Value	Note
PIC	PIC0REG200	18	PIC0REG20018	1	Selects TOUT of TAUB0CH02.
	PIC0REG201	27, 26	PIC0REG20127	1	Negative W phase active high output from the combinational circuit
			PIC0REG20126	0	
		25, 24	PIC0REG20125	1	Positive W phase active high output from the combinational circuit
			PIC0REG20124	0	
		23, 22	PIC0REG20123	1	Negative V phase active high output from the combinational circuit
			PIC0REG20122	0	
		21, 20	PIC0REG20121	1	Positive V phase active high output from the combinational circuit
	PIC0REG20120		0		
	19, 18	PIC0REG20119	1	Negative U phase active high output from the combinational circuit	
		PIC0REG20118	0		
	17, 16	PIC0REG20117	1	Positive U phase active high output from the combinational circuit	
		PIC0REG20116	0		
	PIC0REG202	25, 24	PIC0REG20225	1	The input selected with PIC0REG20018 bit is selected.
			PIC0REG20224	0	
		21, 20	PIC0REG20221	1	The input selected with PIC0REG20018 bit is selected.
	PIC0REG203	17, 16	PIC0REG20217	1	The input selected with PIC0REG20018 bit is selected.
			PIC0REG20216	0	
		22 to 20	PIC0REG20322	1	Negative W phase active high output from the logical operation circuit
	18 to 16	PIC0REG20321	0		
		14 to 12	PIC0REG20318	1	Positive W phase active high output from the logical operation circuit
	PIC0REG20317		0		
	10 to 8	PIC0REG20314	1	Negative V phase active high output from the logical operation circuit	
PIC0REG20313		0			
6 to 4	PIC0REG20312	0			
	PIC0REG20310	1	Positive V phase active high output from the logical operation circuit		
2 to 0	PIC0REG20309	0			
	PIC0REG20308	0			
PIC0REG20306	1	PIC0REG20306	1	Negative U phase active high output from the logical operation circuit	
		PIC0REG20305	0		
PIC0REG20304	0	PIC0REG20304	0		
		PIC0REG20302	1	Positive U phase active high output from the logical operation circuit	
PIC0REG20301	0				
PIC0REG20300	0				

24.4.4 Trigger and Pulse Width Measurement Function

24.4.4.1 Functional Overview

This function allows measurement of trigger periods by inputting the trigger signal output from ENCA0 to TAUJ0 and TAUB0.

24.4.4.2 Configuration

Note: In this section, signal names are abbreviated as shown below.

INT_m → TAUB0INT_m or TAUJ0INT_m

TIN_m → TAUB0TTIN_m or TAUJ0TTIN_m

TOUT_m → TAUB0TTOUT_m or TAUJ0TTOUT_m

CDR_m → TAUB0CDR_m or TAUJ0CDR_m

CNT_m → TAUB0CNT_m or TAUJ0CNT_m

Configuration/ Timer Function	ENCA	TAUB	TAUJ
Timer configuration	ENCA0	TAUB0	TAUJ0

- Setting functions of TAUJ/TAUB0 channels

TAU	CH	Function Name	M/S*	Target Trigger for Pulse Width Measurement
TAUJ0	00	TIN _m input pulse interval measurement function	S	ENCAT0IEC
	01	TIN _m input pulse interval measurement function	S	ENCAT0IEC
TAUB0	00	TIN _m input pulse interval measurement function	S	ENCAT0EQ0 or ENCAT0EQ1
	01	TIN _m input pulse interval measurement function	S	ENCAT0EQ1
	02	TIN _m input pulse interval measurement function	S	ENCAT0EQ0

Note * M = master channel, S = slave channel

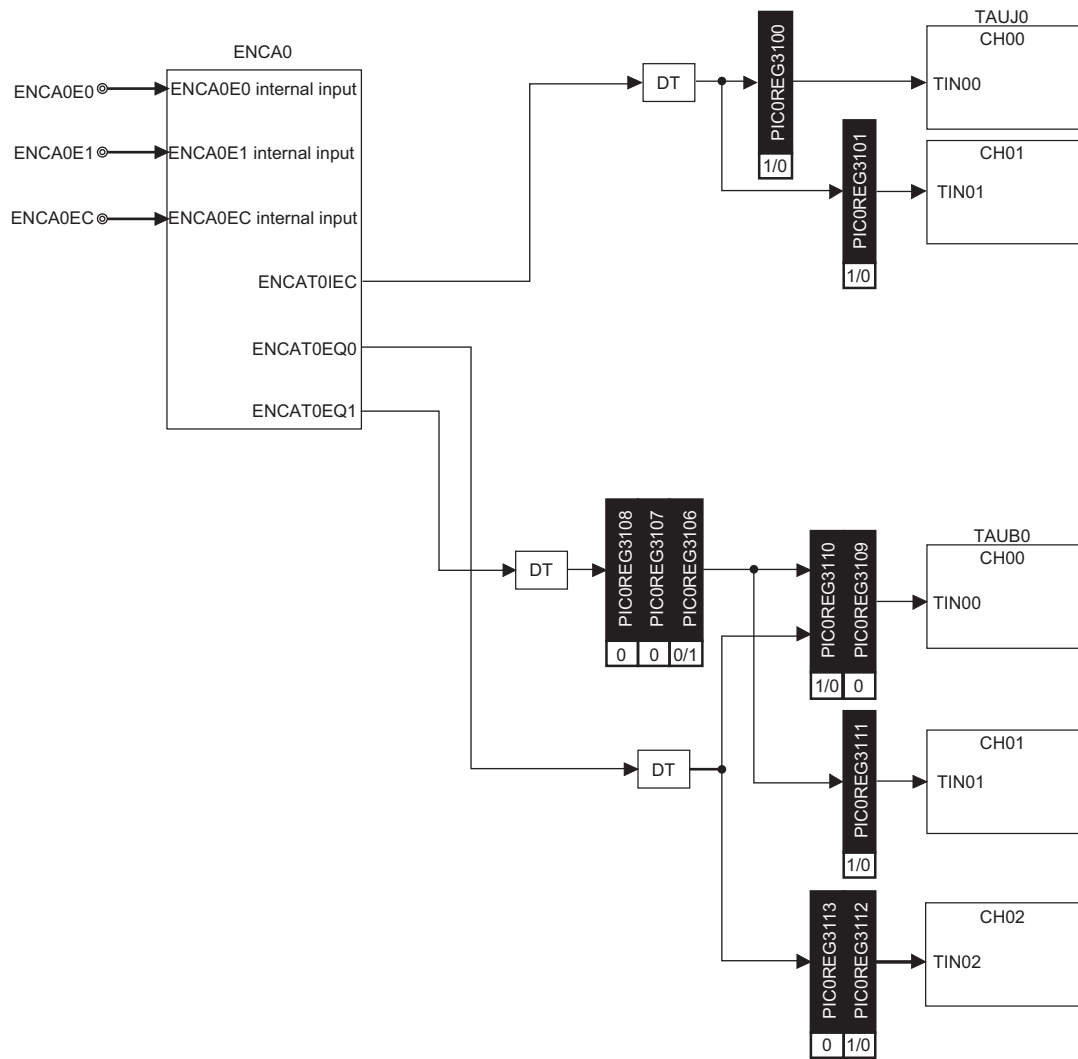

Figure 24-16 Block Diagram

24.4.4.3 Registers**(1) Timer I/O Control Register 30 (PIC0REG30)****Access** This register can be read/written in 32-bit units.**Address** FF81 C0E8_H**Initial value** 0000 0000_H

This register is initialized by any reset.

31	30	29	28	27	26	25	24
0	0	0	0	0	0	0	0
R	R	R	R	R	R	R	R
23	22	21	20	19	18	17	16
0	0	0	0	0	0	0	0
R	R	R	R	R	R/W	R	R
15	14	13	12	11	10	9	8
0	0	0	0	0	0	0	0
R	R	R	R	R	R	R	R
7	6	5	4	3	2	1	0
0	0	0	0	0	0	0	0
R	R	R	R/W	R/W	R/W	R	R

Note Set 0 to bits 18, and 4 to 2 in the PIC0REG30 register.

(2) Timer I/O Control Register 31 (PIC0REG31)

Access This register can be read/written in 32-bit units.

Address FF81 C0EC_H

Initial value 0000 0000_H

This register is initialized by any reset.

31	30	29	28	27	26	25	24
0	0	0	0	0	0	0	0
R	R	R	R	R	R	R	R
23	22	21	20	19	18	17	16
0	0	0	0	0	0	0	0
R	R	R	R	R	R	R	R
15	14	13	12	11	10	9	8
0	0	PIC0REG3113	PIC0REG3112	PIC0REG3111	PIC0REG3110	PIC0REG3109	PIC0REG3108
R	R	R/W	R/W	R/W	R/W	R/W	R/W
7	6	5	4	3	2	1	0
PIC0REG3107	PIC0REG3106	0	0	0	0	PIC0REG3101	PIC0REG3100
R/W	R/W	R	R	R	R	R/W	R/W

Table 24-20 PIC0REG31 Contents (1/2)

Bit Position	Bit Name	Function												
13 12	PIC0REG3113 PIC0REG3112	Selects the TIN signal input of TAUB0CH02. <table border="1" style="margin-left: 20px;"> <thead> <tr> <th>PIC0REG3113</th> <th>PIC0REG3112</th> <th>Input Signal</th> </tr> </thead> <tbody> <tr> <td>0</td> <td>0</td> <td>TIN pin input (TAUB0CH02 is not used for trigger width measurement)</td> </tr> <tr> <td>0</td> <td>1</td> <td>DT output signal from ENCAT0EQ0</td> </tr> <tr> <td colspan="2">Other than the above</td> <td>Setting is prohibited.</td> </tr> </tbody> </table>	PIC0REG3113	PIC0REG3112	Input Signal	0	0	TIN pin input (TAUB0CH02 is not used for trigger width measurement)	0	1	DT output signal from ENCAT0EQ0	Other than the above		Setting is prohibited.
PIC0REG3113	PIC0REG3112	Input Signal												
0	0	TIN pin input (TAUB0CH02 is not used for trigger width measurement)												
0	1	DT output signal from ENCAT0EQ0												
Other than the above		Setting is prohibited.												
11	PIC0REG3111	Selects the TIN signal input of TAUB0CH01.0: TIN pin input (TAUB0CH01 is not used for trigger width measurement)1: Signal selected with PIC0REG3106 to PIC0REG3108 (ENCAT0EQ1 signal is measured)												
10 9	PIC0REG3110 PIC0REG3109	Selects the TIN signal input of TAUB0CH00. <table border="1" style="margin-left: 20px;"> <thead> <tr> <th>PIC0REG3110</th> <th>PIC0REG3109</th> <th>Input Signal</th> </tr> </thead> <tbody> <tr> <td>0</td> <td>0</td> <td>Signal selected with PIC0REG3106 to PIC0REG3108 (ENCAT0EQ1 signal is measured)</td> </tr> <tr> <td>1</td> <td>0</td> <td>DT output signal from ENCAT0EQ0</td> </tr> <tr> <td colspan="2">Other than the above</td> <td>Setting is prohibited.</td> </tr> </tbody> </table>	PIC0REG3110	PIC0REG3109	Input Signal	0	0	Signal selected with PIC0REG3106 to PIC0REG3108 (ENCAT0EQ1 signal is measured)	1	0	DT output signal from ENCAT0EQ0	Other than the above		Setting is prohibited.
PIC0REG3110	PIC0REG3109	Input Signal												
0	0	Signal selected with PIC0REG3106 to PIC0REG3108 (ENCAT0EQ1 signal is measured)												
1	0	DT output signal from ENCAT0EQ0												
Other than the above		Setting is prohibited.												

Table 24-20 PIC0REG31 Contents (2/2)

Bit Position	Bit Name	Function																
8 7 6	PIC0REG3108 PIC0REG3107 PIC0REG3106	Selects the TIN signal input of TAUB0CH00 and TAUB0CH01. <table border="1" style="margin-left: 20px;"> <thead> <tr> <th>PIC0REG3108</th> <th>PIC0REG3107</th> <th>PIC0REG3106</th> <th>Input Signal</th> </tr> </thead> <tbody> <tr> <td>0</td> <td>0</td> <td>0</td> <td>TIN pin input (TAUB0CH00 and TAUB0CH01 are not used for trigger width measurement)</td> </tr> <tr> <td>0</td> <td>0</td> <td>1</td> <td>DT output signal from ENCAT0EQ1</td> </tr> <tr> <td colspan="3">Other than the above</td> <td>Setting is prohibited.</td> </tr> </tbody> </table>	PIC0REG3108	PIC0REG3107	PIC0REG3106	Input Signal	0	0	0	TIN pin input (TAUB0CH00 and TAUB0CH01 are not used for trigger width measurement)	0	0	1	DT output signal from ENCAT0EQ1	Other than the above			Setting is prohibited.
PIC0REG3108	PIC0REG3107	PIC0REG3106	Input Signal															
0	0	0	TIN pin input (TAUB0CH00 and TAUB0CH01 are not used for trigger width measurement)															
0	0	1	DT output signal from ENCAT0EQ1															
Other than the above			Setting is prohibited.															
1	PIC0REG3101	Selects the TIN signal input of TAUJ0CH01. 0: TIN pin input (TAUJ0CH01 is not used for trigger width measurement) 1: DT output signal from ENCAT0IEC																
0	PIC0REG3100	Selects the TIN signal input of TAUJ0CH00. 0: TIN pin input (TAUJ0CH00 is not used for trigger width measurement) 1: DT output signal from ENCAT0IEC																

Caution The bit might be defined to 0 by other timer connection functions. In that case, apply the bit definition of the corresponding PIC connection function.

(3) DT initializing register 01 (PIC0INI01)

Access This register can be read/written in 8-bit units. It is always read as 0.

Address FFFF DB24_H

Initial value 00_H

This register is initialized by any reset.

7	6	5	4	3	2	1	0
0	0	0	0	0	PIC0INI 0102	PIC0INI 0101	PIC0INI 0100
R	R	R	R	R	R/W	R/W	R/W

Table 24-21 PIC0INI01 Contents

Bit Position	Bit Name	Function
2 to 0	PIC0INI010[2-0]	Initialize the DT circuit. 0: Disabled 1: Initialized

24.4.4.4 Example of Operation

The trigger and pulse width measurement function is achieved by combining the ENCA0 interrupt trigger signals (ENCAT0IEC, ENCAT0EQ0, and ENCAT0EQ1) and TINm input pulse interval measurement function of TAUB0 and TAUJ0.

- TINm Input Pulse Interval Measurement Function

Also, the DT circuit in the PIC is used to convert the interrupt trigger signal input to TINm into the level-sensitive toggle signal.

- DT Circuit

The trigger and pulse width measurement function implements measurement of the ENCA0 output interrupt trigger signal interval using the TINm input pulse interval measurement function of TAUB0 and TAUJ0.

(1) TINm Input Pulse Interval Measurement Function

When the valid TINm edge of TAUB0 or TAUJ0 is detected, the CNTm value is captured into CDRn and the CNTm is cleared.

Caution Set the both edges (rising and falling edges) of TINm to be detected as valid for this function.

For details of the TAUB0 and TAUJ0 functions, see the corresponding sections.

(2) DT Circuit

The DT circuit is used to convert the interrupt trigger signal output from ENCA0 into the level-sensitive toggle signal.

As shown in Figure 24-28, Operation Example of Control Method 1 at Up Count, the output signal is toggled on each input interrupt trigger signal generation.

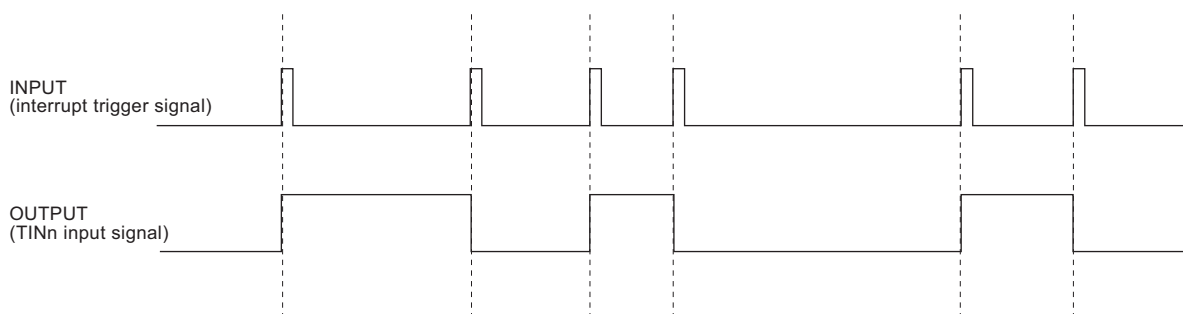

Figure 24-17 DT Circuit Operation

The PIC provides the input signal conversion and signal connection to TAUB0 and TAUJ0 to measure the generation interval of interrupt trigger signals from ENCA0.

Figure 24-18 shows the timing chart of the trigger and pulse width measurement function.

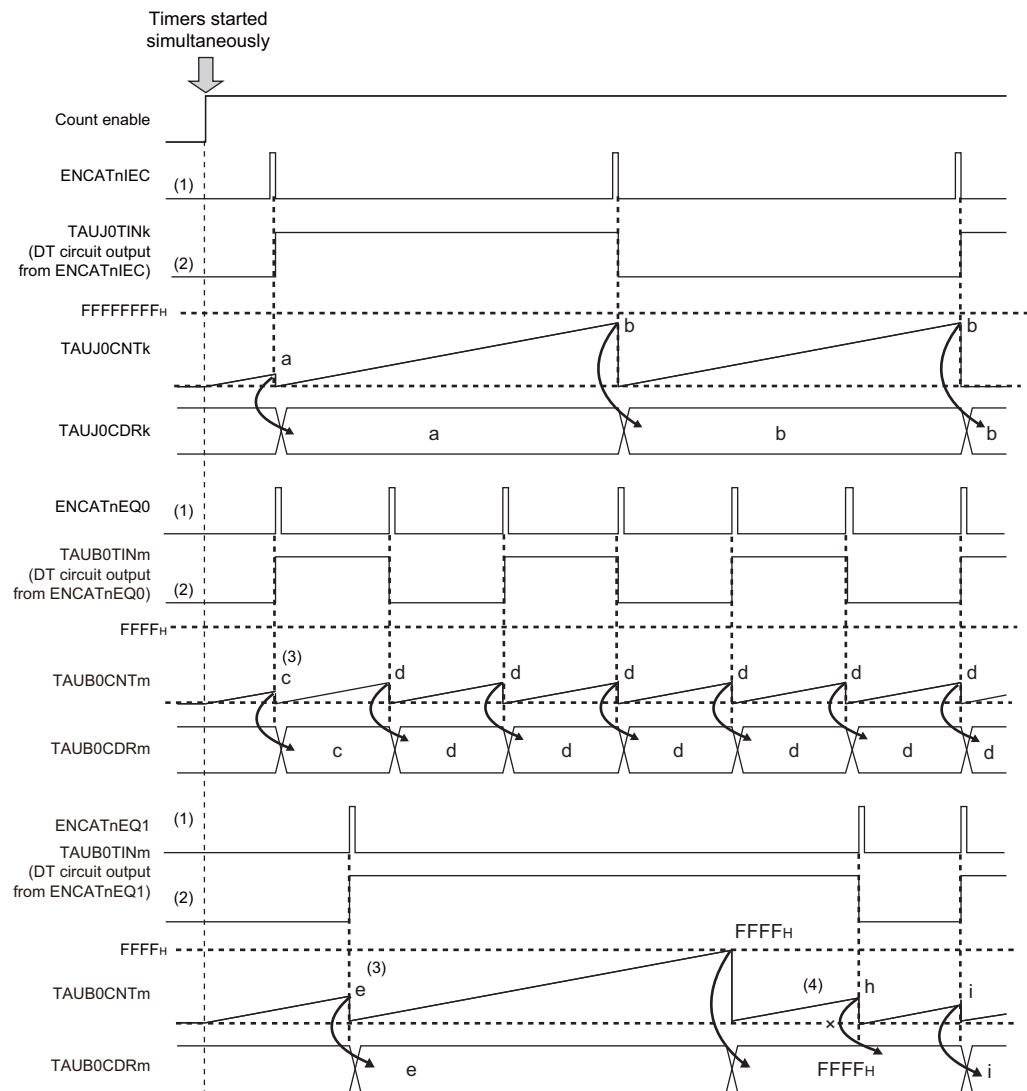

Figure 24-18 Operation Example of Trigger and Pulse Width Measurement Function (m = 0 to 2, k = 0, 1)

- Following signal is output from encoder timer ENCA0 as a trigger:
 - ENCAT0IEC (interrupt trigger signal output when timer counter value is cleared by ENCA0EC input)
 - ENCAT0EQ0 (interrupt trigger signal output according to timing of a match of timer counter value and value of compare register 0)
 - ENCAT0EQ1 (interrupt trigger signal output according to timing of a match of timer counter value and value of compare register 1)
- The interrupt trigger signal output from ENCA0 is converted to the level-sensitive toggle signal by the DT circuit and is output to TINm of TAUB0 and TAUJ0.
- By setting the both edges of TINm of TAUB0 and TAUJ0 as valid, the CNTm value is captured into CDRn on the TINm toggle timing and cleared to 0000_H. This operation is repeated.
- When an overflow occurs, the count value FFFF_H (FFFFFFF_H for TAUJ) is captured but the count value is not captured on the first trigger after the overflow.

With the above operation, the trigger period can be measured.

The following shows the combinations of the interrupt trigger signals and measurement timers and the pertinent PIC register bits for setting the signal paths. Appropriately set the measurement timer and signal path with the PIC register bits according to the interrupt trigger signal to be measured.

Table 24-22 Combinations of Interrupt Trigger Signals and Measurement Timers

Encoder Timer	Interrupt Trigger Signal	Measurement Timer Channel	PIC Register Bit
ENCA0	ENCAT0IEC	TAUJ0-CH00	PIC0REG3100
		TAUJ0-CH01	PIC0REG3101
	ENCAT0EQ0	TAUB0-CH00	PIC0REG3109, PIC0REG3110
		TAUB0-CH02	PIC0REG3112, PIC0REG3113
	ENCAT0EQ1	TAUB0-CH00	PIC0REG3106, PIC0REG3107 PIC0REG3108, PIC0REG3109 PIC0REG3110
		TAUB0-CH01	PIC0REG3106, PIC0REG3107 PIC0REG3108, PIC0REG3111

24.4.4.5 Operation Flow

Figure 24-19 and Figure 24-20 in this section show the general setting flow to measure the pulse interval, which applies to all the following combinations. Change the register settings indicated with the symbol "*" depending on the interrupt trigger signal to be measured and timer to be used. For the combinations of the interrupt trigger signals and timers, see Table 24-22, Combinations of Interrupt Trigger Signals and Measurement Timers.

Encoder Timer	Interrupt Trigger Signal	Measurement Timer Channel
ENCA0	ENCAT0IEC	TAUJ0-CH00, TAUJ0-CH01
	ENCAT0EQ0	TAUB0-CH00, TAUB0-CH02
	ENCAT0EQ1	TAUB0-CH01

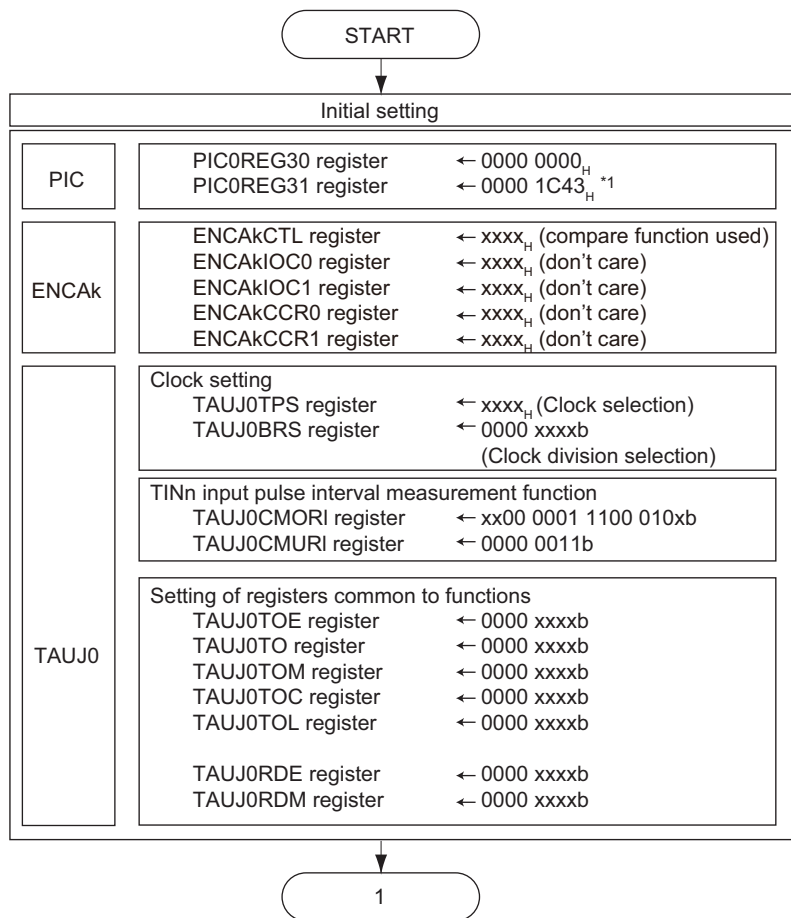

Figure 24-19 Setting Flow (k = 0, l = 0, 1)

Note Change the settings depending on the combination of the interrupt trigger signal to be measured and timer to be used.

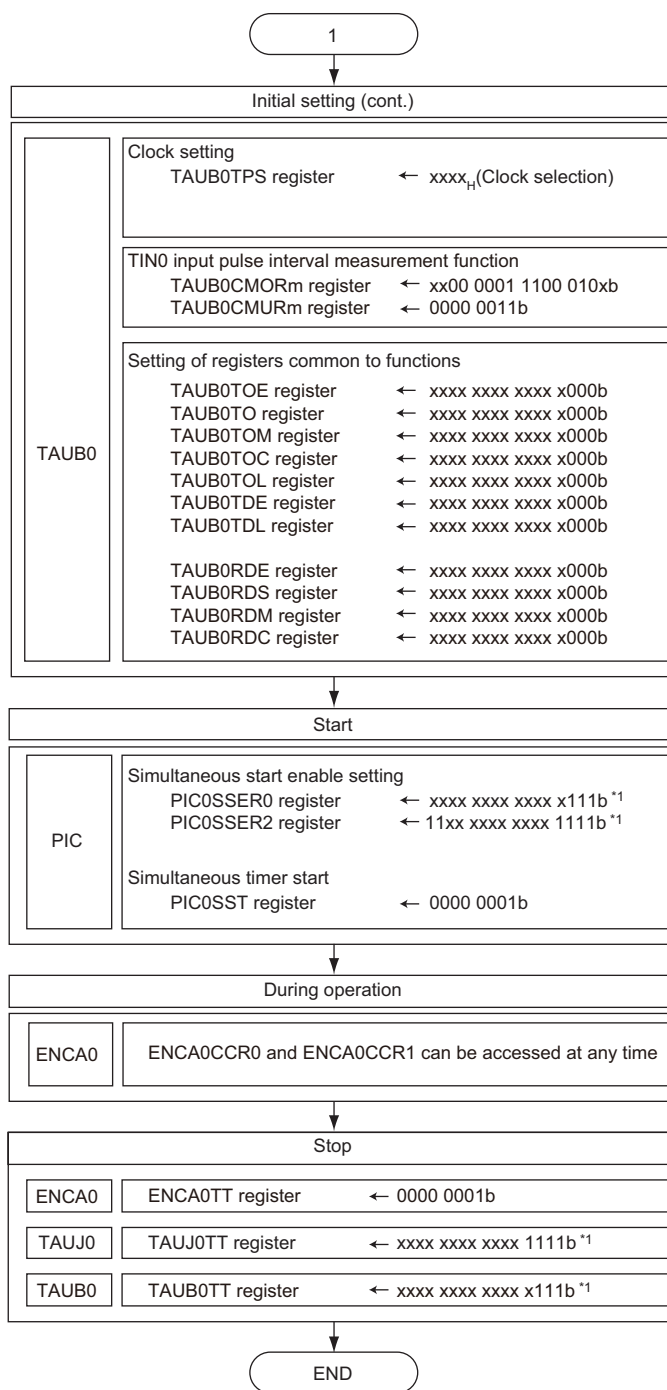

Figure 24-20 Setting Flow (cont.) (m = 0 to 2)

Note Change the settings depending on the combination of the interrupt trigger signal to be measured and timer to be used.

24.4.4.6 Register Setting Examples for Various Functions

Register setting

Tables in this section show the setting example to measure the pulse interval, which applies to all the following combinations. For the combinations of the interrupt trigger signals and timers, see Table 24-33, PIC0REG50 Contents.

Encoder Timer	Interrupt Trigger Signal	Measurement Timer Channel
ENCA0	ENCAT0IEC	TAUJ0-CH00, TAUJ0-CH01
	ENCAT0EQ0	TAUB0-CH00, TAUB0-CH02
	ENCAT0EQ1	TAUB0-CH01

Table 24-23 ENCA0 Setting

Function	Register	Bit Position	Bit Name	Set Value	Note	
ENCA0	ENCA0CTL	15	ENCA0CME	Don't care	Enables or disables compare match interrupt detection mask.	
		14	ENCA0MCS	Don't care	Selects a cancelation trigger of compare match interrupt detection mask.	
		13 to 10		0	Fixed to 0	
		9	ENCA0CRM1	Don't care	Selects the ENCA0CCR1 function.	
		8	ENCA0CRM0	Don't care	Selects the ENCA0CCR0 function.	
		7	ENCA0CTS	Don't care	Selects trigger of capture operation of ENCA0CCR1.	
		6, 5		0	Fixed to 0	
		4	ENCA0LDE	Don't care	Enables or disables reload operation when underflow is generated.	
		3	ENCA0ECM1	Don't care	Enables or disables clearing of the counter on compare match of ENCA0CCR1.	
		2	ENCA0ECM0	Don't care	Enables or disables clearing of the counter on compare match of ENCA0CCR0.	
		1, 0	ENCA0UDS1, ENCA0UDS0	Don't care	Selects the counter up/down control by ENCA0E0/ENCA0E1.	
	ENCA0IOC0	7 to 4			0	Fixed to 0
			3, 2	ENCA0TIS3, ENCA0TIS2	Don't care	Selects the effective edge for capture trigger 1 (ENCA0I1).
			1, 0	ENCA0TIS3, ENCA0TIS2	Don't care	Selects the effective edge for capture trigger 0 (ENCA0I0).
	ENCA0IOC1	7	7	ENCA0SCE	Don't care	Enables the special encoder clear.
			6	ENCA0ZCL	Don't care	Selects the clear level of Z phase for a special encoder clear.
			5	ENCA0BCL	Don't care	Selects the clear level of B phase for a special encoder clear.
			4	ENCA0ACL	Don't care	Selects the clear level of A phase for a special encoder clear.
			3, 2	ENCA0ECS1, ENCA0ECS0	Don't care	Selects encoder clear input (Z phase) edge.
			1, 0	ENCA0EIS1, ENCA0EIS0	Don't care	Selects encoder input (A and B phase) edge.

Table 24-24 TAUJ0 Setting (k = 0, 1)

TAUJ0 (TINm input pulse interval measurement function)

Function	Register	Bit Position	Bit Name	Set Value	Note
TAUJ0	TAUJ0 CMORk	15, 14	CKS1	Don't care	Sets the operating clock.
			CKS0		
		13, 12	CCS1	0	
			CCS0	0	
		11	MAS	1	
		10 to 8	STS2	0	
			STS1	0	
			STS0	0	
		7, 6	COS1	1	
			COS0	1	
		5		0	Fixed to 0
		4	MD4	0	
	3	MD3	0		
2	MD2	1			
1	MD1	0			
0	MD0	Don't care			
	TAUJ0 CMURk	1, 0	TIS1 TIS0	1 1	

Note When TAUJ0CMORk is used for the TINm input pulse interval measurement function, the CKS (operating clock selection) and MD0 (INTn output control at the start of counting) bits can be set arbitrarily.

Though the COS (overflow mode selection) bit can also be set arbitrarily, it should be fixed to 0 for this function.

Other control bits have fixed values as specified above. For details, refer to Section 14, Timer Array Unit J (TAUJ).

For TAUJ common registers (TOE, TO, TOM, TOC, TOL, TDE, TDM, TDL, TRE, TRO, TRC, TME, RDE, RDS, RDM, and RDC), only set the bits corresponding to the used channels to 0.

Table 24-25 TAUB0 Setting (m = 0 to 2)

TAUB0 (TINm input pulse interval measurement function)

Function	Register	Bit Position	Bit Name	Set Value	Note
TAUB0	TAUB0 CMORm	15, 14	CKS1	Don't care	Sets the operating clock.
			CKS0		
		13, 12	CCS1	0	
			CCS0	0	
		11	MAS	1	
		10 to 8	STS2	0	
			STS1	0	
			STS0	0	
		7, 6	COS1	1	
			COS0	1	
		5		0	Fixed to 0
		4	MD4	0	
	3	MD3	0		
2	MD2	1			
1	MD1	0			
0	MD0	Don't care			
	TAUB0 CMURm	1, 0	TIS1 TIS0	1 1	

Note When TAUB0CMORm is used for the TINm input pulse interval measurement function, the CKS (operating clock selection) and MD0 (INTn output control at the start of counting) bits can be set arbitrarily.

Though the COS (overflow mode selection) bit can also be set arbitrarily, it should be fixed to 0 for this function.

Other control bits have fixed values as specified above. For details, refer to Section 13, Timer Array Unit B (TAUB).

For TAUB common registers (TOE, TO, TOM, TOC, TOL, TDE, TDL, RDE, RDS, RDM, and RDC), only set the bits corresponding to the used channels to 0.

Table 24-26 PIC Setting

Function	Register	Bit Position	Bit Name	Set Value	Note
PIC	PIC0REG 31	13, 12	PIC0REG3113	0	Selects DT output signal from ENCAT0EQ0 as TIN input signal of TAUB0CH02.
			PIC0REG3112	1	
		11	PIC0REG3111	1	Selects the signal selected with PIC0REG3106 to PIC0REG3108 (DT output signal from ENCAT0EQ1) as TIN input signal of TAUB0CH01.
		10, 9	PIC0REG3110	1	Selects DT output signal from ENCAT1EQ0 as TIN input signal of TAUB0CH00.
			PIC0REG3109	0	
		8 to 6	PIC0REG3108	0	Selects DT output signal from ENCAT0EQ1 as TIN input signal of TAUB0CH01 and TAUB0CH00.
			PIC0REG3107 PIC0REG3106	0 1	
1	PIC0REG3101	1	Selects DT output signal from ENCAT0IEC as TIN input signal of TAUJ0CH01.		
0	PIC0REG3100	1	Selects DT output signal from ENCAT0IEC as TIN input signal of TAUJ0CH00.		

24.4.5 Encoder Capture Trigger Selection Function

24.4.5.1 Functional Overview

ADCA_nTRG_i or INTTAUB_nINT_m can be selected and connected as ENCA0 capture trigger signal.

24.4.5.2 Configuration

Configuration/ Timer Function	ENCA
Timer configuration	ENCA0

Configuration/ Signal output function	ADCA	TAUB
Encoder capture signal	ADCA _n TRG _i	TAUB0TINT _m

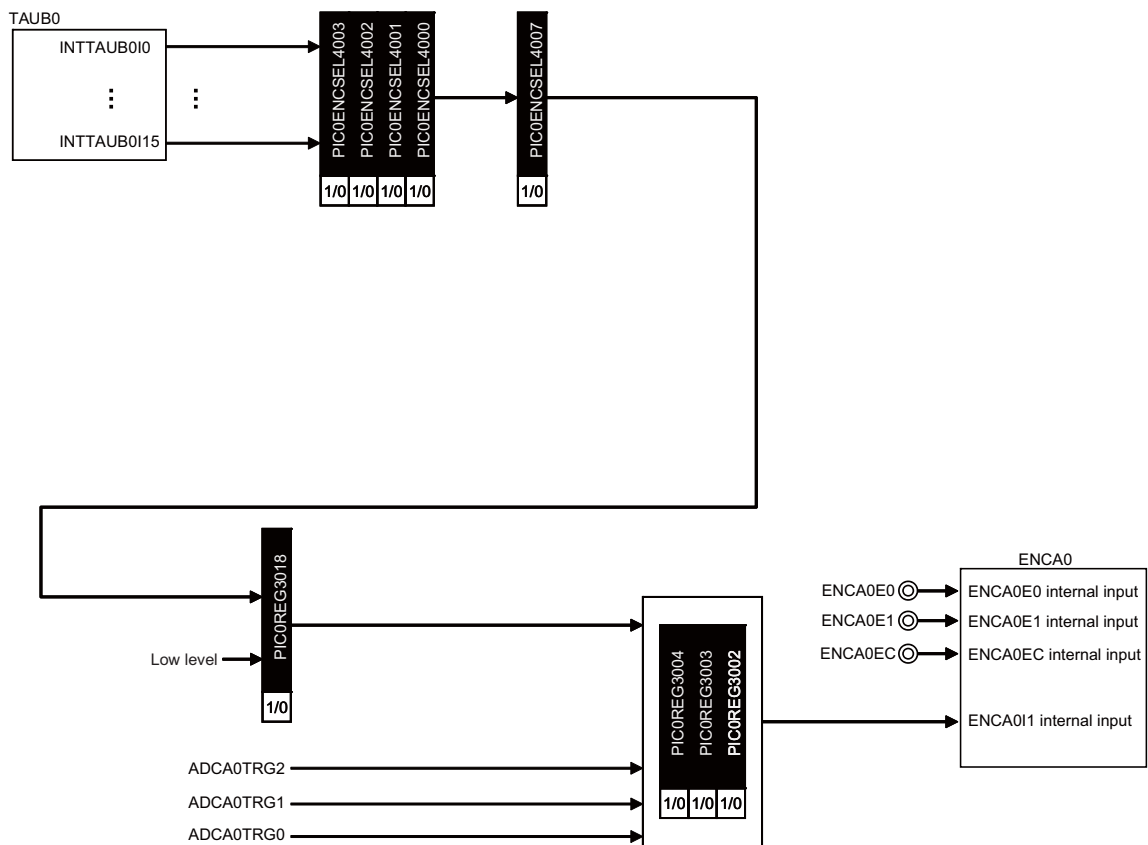

Figure 24-21 Block Diagram

24.4.5.3 Registers

(1) Timer I/O Control Register 30 (PIC0REG30)

Access This register can be read/written in 32-bit units.

Address FF81 C0E8_H

Initial value 0000 0000_H

This register is initialized by any reset.

31	30	29	28	27	26	25	24
0	0	0	0	0	0	0	0
R	R	R	R	R	R	R	R
23	22	21	20	19	18	17	16
0	0	0	0	0	PIC0REG3018	0	0
R	R	R	R	R	R/W	R	R
15	14	13	12	11	10	9	8
0	0	0	0	0	0	0	0
R	R	R	R	R	R	R	R
7	6	5	4	3	2	1	0
0	0	0	PIC0REG3004	PIC0REG3003	PIC0REG3002	0	0
R	R	R	R/W	R/W	R/W	R	R

Table 24-27 PIC0REG30 Contents

Bit Position	Bit Name	Function																								
18	PIC0REG3018	Selects the signal to supply the values of the PIC0REG30[4:2] bits. 0: Low level input signal 1: The signal selected by the PIC0ENCSEL4007 bit in the PIC0ENCSEL400 register.																								
4 3 2	PIC0REG3004 PIC0REG3003 PIC0REG3002	Selects the signal to be input to ENCA0I1 in ENCA0 (internal signal). <table border="1" style="margin-left: 20px;"> <thead> <tr> <th>PIC0REG3004</th> <th>PIC0REG3003</th> <th>PIC0REG3002</th> <th>Input Signal</th> </tr> </thead> <tbody> <tr> <td>0</td> <td>0</td> <td>0</td> <td>Signal selected by PIC0REG3018.</td> </tr> <tr> <td>0</td> <td>1</td> <td>0</td> <td>ADCA0TRG2</td> </tr> <tr> <td>0</td> <td>1</td> <td>1</td> <td>ADCA0TRG1</td> </tr> <tr> <td>1</td> <td>0</td> <td>0</td> <td>ADCA0TRG0</td> </tr> <tr> <td colspan="3" style="text-align: center;">Other than the above</td> <td>Setting is prohibited.</td> </tr> </tbody> </table>	PIC0REG3004	PIC0REG3003	PIC0REG3002	Input Signal	0	0	0	Signal selected by PIC0REG3018.	0	1	0	ADCA0TRG2	0	1	1	ADCA0TRG1	1	0	0	ADCA0TRG0	Other than the above			Setting is prohibited.
PIC0REG3004	PIC0REG3003	PIC0REG3002	Input Signal																							
0	0	0	Signal selected by PIC0REG3018.																							
0	1	0	ADCA0TRG2																							
0	1	1	ADCA0TRG1																							
1	0	0	ADCA0TRG0																							
Other than the above			Setting is prohibited.																							

Caution The bit might be defined to 0 by other timer connection functions. In that case, apply the bit definition of the corresponding PIC connection function.

(2) Encoder Input Signal 1 Selecting Register 400 (PIC0ENCSEL400)

Access This register can be read/written in 8-bit units.

Address FF81 C0B8_H

Initial value 00_H

This register is initialized by any reset.

	7	6	5	4	3	2	1	0
PIC0ENCSEL4007	0	0	0	PIC0ENCSEL4003	PIC0ENCSEL4002	PIC0ENCSEL4001	PIC0ENCSEL4000	
R/W	R	R	R	R/W	R/W	R/W	R/W	

Table 24-28 PIC0ENCSEL400 Contents

Bit Position	Bit Name	Function																																																																																									
7	PIC0ENCSEL4007	Enables or disables the output of the INTTAUB0Im signal selected by the PIC0ENCSEL400[3:0] bits. 0: Disables the output of the TAUB0TINTm signal 1: Enables the output of the TAUB0TINTm signal																																																																																									
3 2 1 0	PIC0ENCSEL4003 PIC0ENCSEL4002 PIC0ENCSEL4001 PIC0ENCSEL4000	Selects the TAUB0TINTm signal as the capture trigger for ENCA0. <table border="1" style="margin-left: 20px;"> <thead> <tr> <th colspan="4">PIC0ENCSEL400</th> <th rowspan="2">Input Signal</th> </tr> <tr> <th>bit3</th> <th>bit2</th> <th>bit1</th> <th>bit0</th> </tr> </thead> <tbody> <tr><td>0</td><td>0</td><td>0</td><td>0</td><td>Selects INTTAUB0I0</td></tr> <tr><td>0</td><td>0</td><td>0</td><td>1</td><td>Selects INTTAUB0I1</td></tr> <tr><td>0</td><td>0</td><td>1</td><td>0</td><td>Selects INTTAUB0I2</td></tr> <tr><td>0</td><td>0</td><td>1</td><td>1</td><td>Selects INTTAUB0I3</td></tr> <tr><td>0</td><td>1</td><td>0</td><td>0</td><td>Selects INTTAUB0I4</td></tr> <tr><td>0</td><td>1</td><td>0</td><td>1</td><td>Selects INTTAUB0I5</td></tr> <tr><td>0</td><td>1</td><td>1</td><td>0</td><td>Selects INTTAUB0I6</td></tr> <tr><td>0</td><td>1</td><td>1</td><td>1</td><td>Selects INTTAUB0I7</td></tr> <tr><td>1</td><td>0</td><td>0</td><td>0</td><td>Selects INTTAUB0I8</td></tr> <tr><td>1</td><td>0</td><td>0</td><td>1</td><td>Selects INTTAUB0I9</td></tr> <tr><td>1</td><td>0</td><td>1</td><td>0</td><td>Selects INTTAUB0I10</td></tr> <tr><td>1</td><td>0</td><td>1</td><td>1</td><td>Selects INTTAUB0I11</td></tr> <tr><td>1</td><td>1</td><td>0</td><td>0</td><td>Selects INTTAUB0I12</td></tr> <tr><td>1</td><td>1</td><td>0</td><td>1</td><td>Selects INTTAUB0I13</td></tr> <tr><td>1</td><td>1</td><td>1</td><td>0</td><td>Selects INTTAUB0I14</td></tr> <tr><td>1</td><td>1</td><td>1</td><td>1</td><td>Selects INTTAUB0I15</td></tr> </tbody> </table>	PIC0ENCSEL400				Input Signal	bit3	bit2	bit1	bit0	0	0	0	0	Selects INTTAUB0I0	0	0	0	1	Selects INTTAUB0I1	0	0	1	0	Selects INTTAUB0I2	0	0	1	1	Selects INTTAUB0I3	0	1	0	0	Selects INTTAUB0I4	0	1	0	1	Selects INTTAUB0I5	0	1	1	0	Selects INTTAUB0I6	0	1	1	1	Selects INTTAUB0I7	1	0	0	0	Selects INTTAUB0I8	1	0	0	1	Selects INTTAUB0I9	1	0	1	0	Selects INTTAUB0I10	1	0	1	1	Selects INTTAUB0I11	1	1	0	0	Selects INTTAUB0I12	1	1	0	1	Selects INTTAUB0I13	1	1	1	0	Selects INTTAUB0I14	1	1	1	1	Selects INTTAUB0I15
PIC0ENCSEL400				Input Signal																																																																																							
bit3	bit2	bit1	bit0																																																																																								
0	0	0	0	Selects INTTAUB0I0																																																																																							
0	0	0	1	Selects INTTAUB0I1																																																																																							
0	0	1	0	Selects INTTAUB0I2																																																																																							
0	0	1	1	Selects INTTAUB0I3																																																																																							
0	1	0	0	Selects INTTAUB0I4																																																																																							
0	1	0	1	Selects INTTAUB0I5																																																																																							
0	1	1	0	Selects INTTAUB0I6																																																																																							
0	1	1	1	Selects INTTAUB0I7																																																																																							
1	0	0	0	Selects INTTAUB0I8																																																																																							
1	0	0	1	Selects INTTAUB0I9																																																																																							
1	0	1	0	Selects INTTAUB0I10																																																																																							
1	0	1	1	Selects INTTAUB0I11																																																																																							
1	1	0	0	Selects INTTAUB0I12																																																																																							
1	1	0	1	Selects INTTAUB0I13																																																																																							
1	1	1	0	Selects INTTAUB0I14																																																																																							
1	1	1	1	Selects INTTAUB0I15																																																																																							

24.4.5.4 Example of Operation

The PIC provides the signal path to connect the ADCAnTRGi (ADCAn conversion start trigger signal i) and TAUB0TINTm (TAUB0-CHm interrupt request signal) to the ENCA0 capture trigger input.

(1) The encoder capture by ADCAnTRGi

The AD trigger encoder capture function is implemented by connecting the AD conversion start trigger signals (ADCA0TRG0, ADCA0TRG1, ADCA0TRG2) to ENCA0.

Caution When using this function, the ENCA0 interrupt trigger signal EQ1 (ENCAT0EQ1) should not be selected as the ADC trigger described in Section 24.4.2, ADC Trigger Selection Function. If selected, the correct operation cannot be performed because the following loop occurs: ADCA0TRG1 generation → ENCA0 capture operation → ENCAT0EQ1 generation by capture operation → ADCA0TRG1 generation.

The following shows a timing chart of the encoder capture trigger selection function using the ADCAnTRG1 as a trigger.

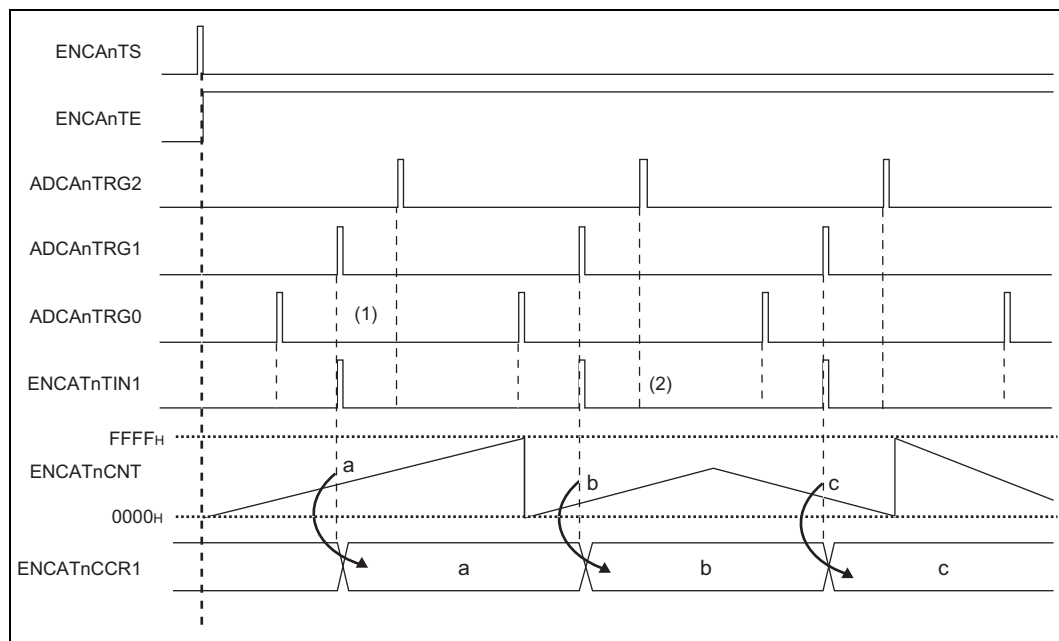

Figure 24-22 Operation Example of Encoder Capture Trigger Selection Function

- (1) When ADCA0TRG1 is selected as the ENCA0 capture trigger 1 signal ENCAT0TIN1, the valid ADCA0TRG1 is input to ENCA0 as the ENCAT0TIN1 signal and ENCA0 is captured.
- (2) When an AD trigger signal other than ADCA0TRG1 (ADCA0TRG0, ADCA0TRG2) is generated, the ENCAT0TIN1 signal is not generated and ENCA0 is not captured.

(2) Encoder Capture by TAUB0TINTm

Encoder capture can be operated after a TAUB0TINTm (TAUB0-CHm interrupt signal) is selected and connected it to ENCA0.

An operation example of this function with TAUB0TINTm trigger for ENCA0 is described below.

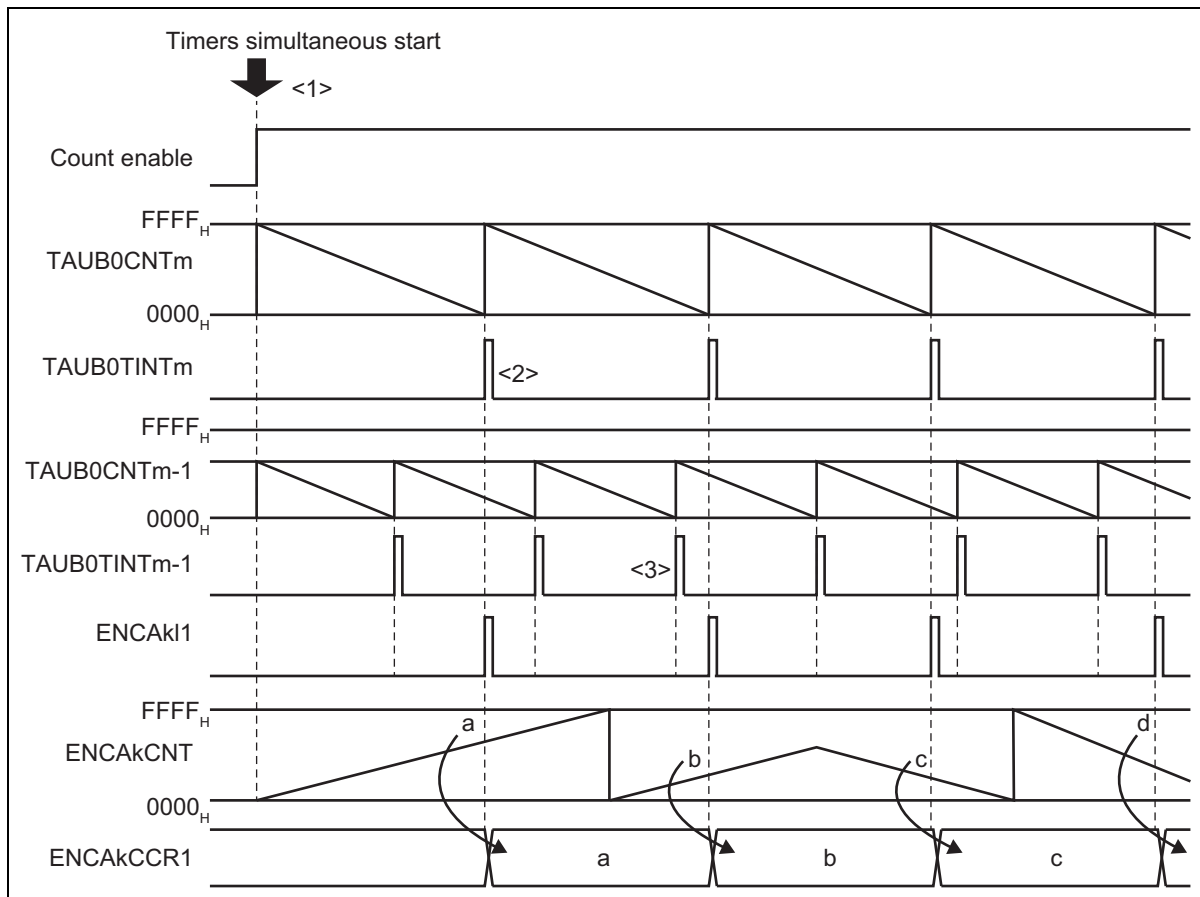

Figure 24-23 Operation example of encoder capture with TAUB0TINTm trigger.

<1> TAUB0CNTm, TAUB0CNTm-1 and ENCA0 start count operation at the same time by a simultaneous start trigger.

<2> When TAUB0TINTm (TAUB0-CHm interrupt request signal) is selected as ENCA011 (ENCA0 capture trigger 1 signal), ENCA0 capture counter value to a capture register by TAUB0TINTm input.

<3> If the input is not TAUB0TINTm but TAUB0TINTm-1 (TAUB0-CHm interrupt request signal), the capture of ENCA0 is not operated.

24.4.5.5 Operation Flow

The figure in this section shows the setting flow to perform capture operation of ENCA0 encoder timer based on the ADCA0TRG1 signal. Change the setting indicated with the symbol "*" depending on the encoder timer to be captured.

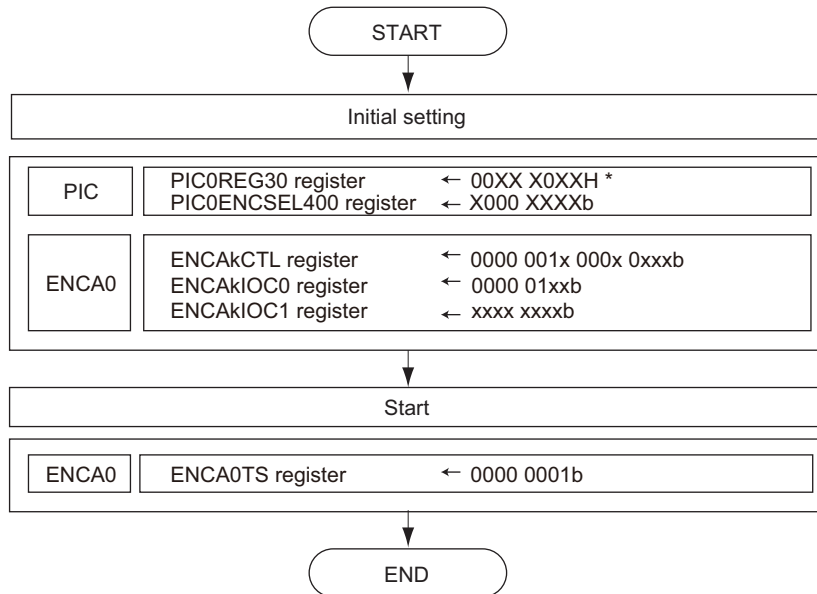

Figure 24-24 Setting Flow

(1) Setting Flow for Encoder Capture Operation by INTTAUB0Im

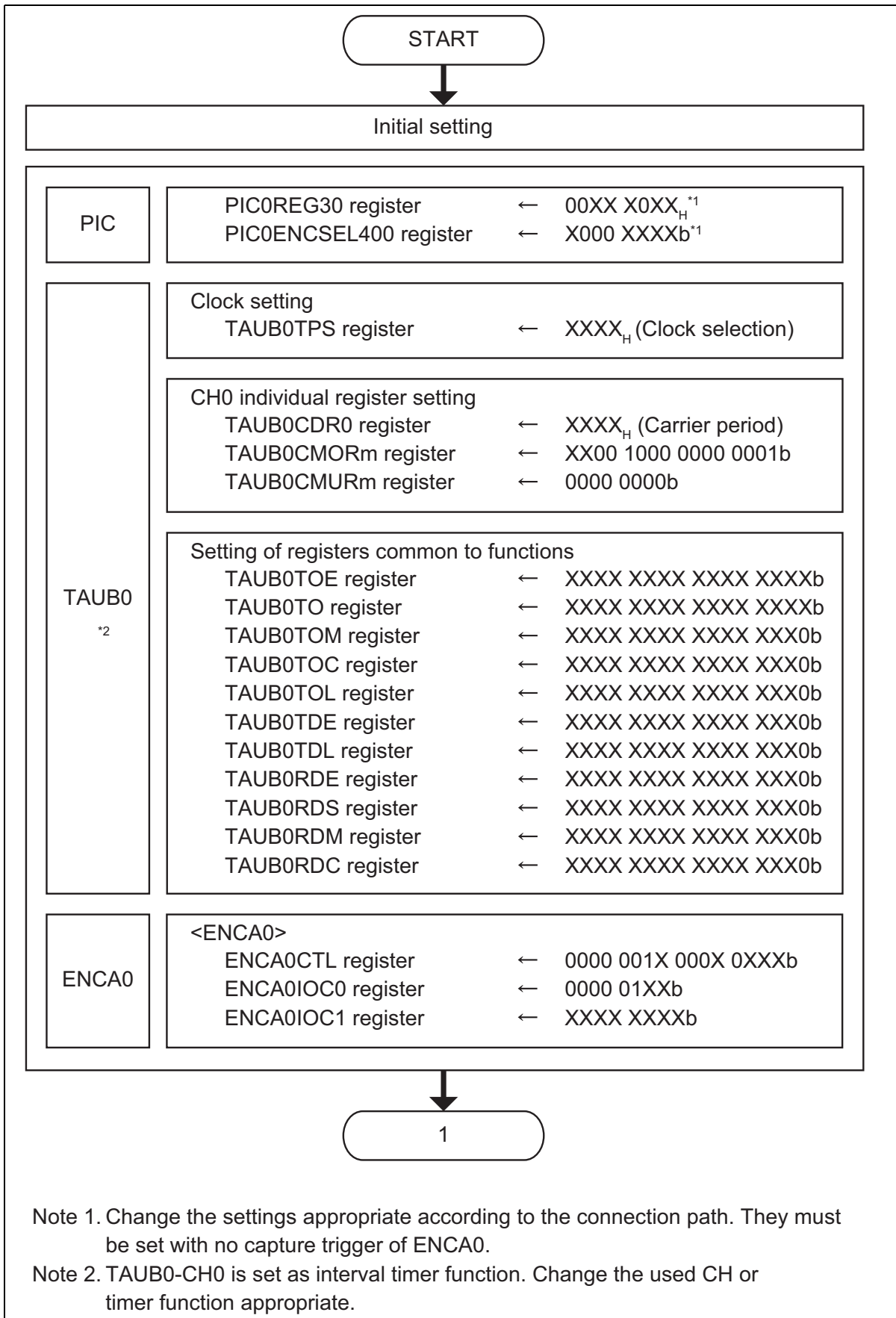

Figure 24-25 Setting Flow for Encoder Capture Operation by INTTAUB0Im (1/2)

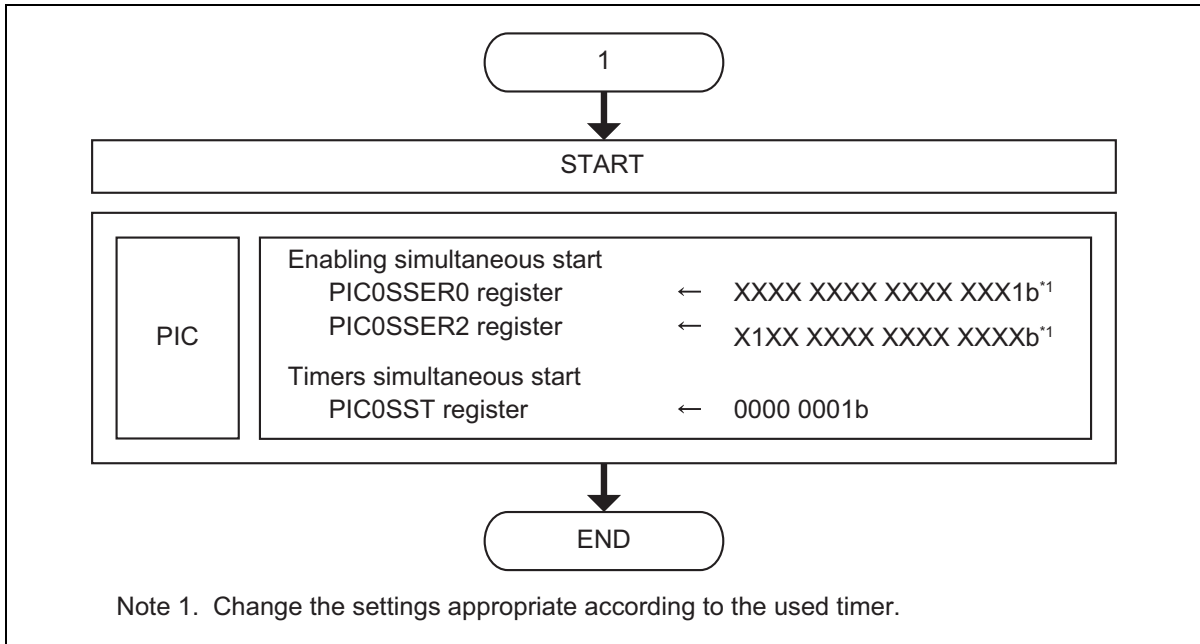

Figure 24-26 Setting Flow for Encoder Capture Operation by INTTAUB0Im (2/2)

24.4.5.6 Register Setting Examples for Various Functions

Register setting

The tables in this section show the setting example to perform capture operation of ENCA0 encoder timer based on the ADCA0TRG1 signal. Change the settings depending on the encoder timer to be captured.

Table 24-29 ENCA0 Setting

Function	Register	Bit Position	Bit Name	Set Value	Note	
ENCA0	ENCA0CTL	15	ENCA0CME	0	Disables compare match interrupt detection mask.	
		14	ENCA0MCS	0	Selects a cancelation trigger of compare match interrupt detection mask.	
		13 to 10		0	Fixed to 0	
		9	ENCA0CRM1	1	Sets ENCA0CCR1 for capture operation.	
		8	ENCA0CRM0	Don't care	Selects the ENCA0CCR0 function	
		7	ENCA0CTS	0* ¹	Selects ENCA0I1 input as trigger of capture operation.	
		6, 5		0	Fixed to 0	
		4	ENCA0LDE	Don't care	Enables or disables reload operation when underflow is generated.	
		3	ENCA0ECM1	Don't care	Enables or disables clearing of the counter on compare match of ENCA0CCR1.	
		2	ENCA0ECM0	Don't care	Enables or disables clearing of the counter on compare match of ENCA0CCR0.	
		1, 0	ENCA0UDS1, ENCA0UDS0	Don't care	Selects the counter up/down control by ENCA0E0/ ENCA0E1.	
		ENCA0IOC0		7 to 4		0
	3, 2			ENCA0TIS3, ENCA0TIS2	0* ¹ 1* ¹	Sets the rising edge of capture trigger 1 (ENCA0I1) as valid.
	1, 0			ENCA0TIS1, ENCA0TIS0	Don't care	Selects the effective edge for capture trigger 0 (ENCA0I0).
	ENCA0IOC1		7	ENCA0SCE	Don't care	Enables the special encoder clear.
			6	ENCA0ZCL	Don't care	Selects the clear level of Z phase for a special encoder clear.
			5	ENCA0BCL	Don't care	Selects the clear level of B phase for a special encoder clear.
			4	ENCA0ACL	Don't care	Selects the clear level of A phase for a special encoder clear.
			3, 2	ENCA0ECS1 ENCA0ECS0	Don't care	Selects encoder clear input (Z phase) edge.
			1, 0	ENCA0EIS1 ENCA0EIS0	Don't care	Selects encoder input (A and B phase) edge.

Note 1. Change the setting depending on the encoder timer to be captured.

Note: All the registers can be set arbitrarily except the bits CRM1 = 1 (ENCA0CCR1 register function) and CTS = 0 (trigger of capture to ENCA0CCR1) in ENCA0CTL for the encoder capture trigger selection function.

Table 24-30 PIC Setting

Function	Register	Bit Position	Bit Name	Set Value	Note
PIC	PIC0REG30	18	PIC0REG3018	Don't care	Selects the signal to supply the values of the PIC0REG30[4:2] bits.
		4 to 2	PIC0REG3004 PIC0REG3003 PIC0REG3002	Don't care	Selects the ENCAT0TIN1 input signal of ENCA0.
	PIC0ENCSEL400	7	PIC0ENCSEL4007	Don't care	Enables or disables the output of the INTTAUB0Im signal selected by the PIC0ENCSEL400[3:0] bits.
		3 to 0	PIC0ENCSEL4003 PIC0ENCSEL4002 PIC0ENCSEL4001 PIC0ENCSEL4000	Don't care	Selects the TAUB0TINTm signal as the capture trigger for ENCA0.

Table 24-31 PIC Setting (Using INTTAUB0Im)

Register	Bit Position	Bit Name	Set Value	Note
PIC0REG30	18	PIC0REG3018	0	Selects INTTAUB0Im (interrupt request signal of TAUB0 channel m).
	4 3 2	PIC0REG3004 PIC0REG3003 PIC0REG3002	000 or 001	Signal selected with PIC0REG 018 or PIC0REG021 bit.
	PIC0ENCSEL400	7	PIC0ENCSEL4007	0
6 to 4			0	Fixed to 0
3 to 0		PIC0ENCSEL4003 PIC0ENCSEL4002 PIC0ENCSEL4001 PIC0ENCSEL4000	Don't care	Set the channel number of TAUB0 used as encoder capture signal.

24.4.6 Two-Phase Encoder Control Function (Control Method 1)

24.4.6.1 Functional Overview

This function allows switching of the output pattern of TSG20 using the two-phase encoder (ENCA timer).

24.4.6.2 Configuration

Configuration/Timer Function	ENCA	TSG2	TAPA
Timer configuration 1	ENCA0	TSG20	TAPA2

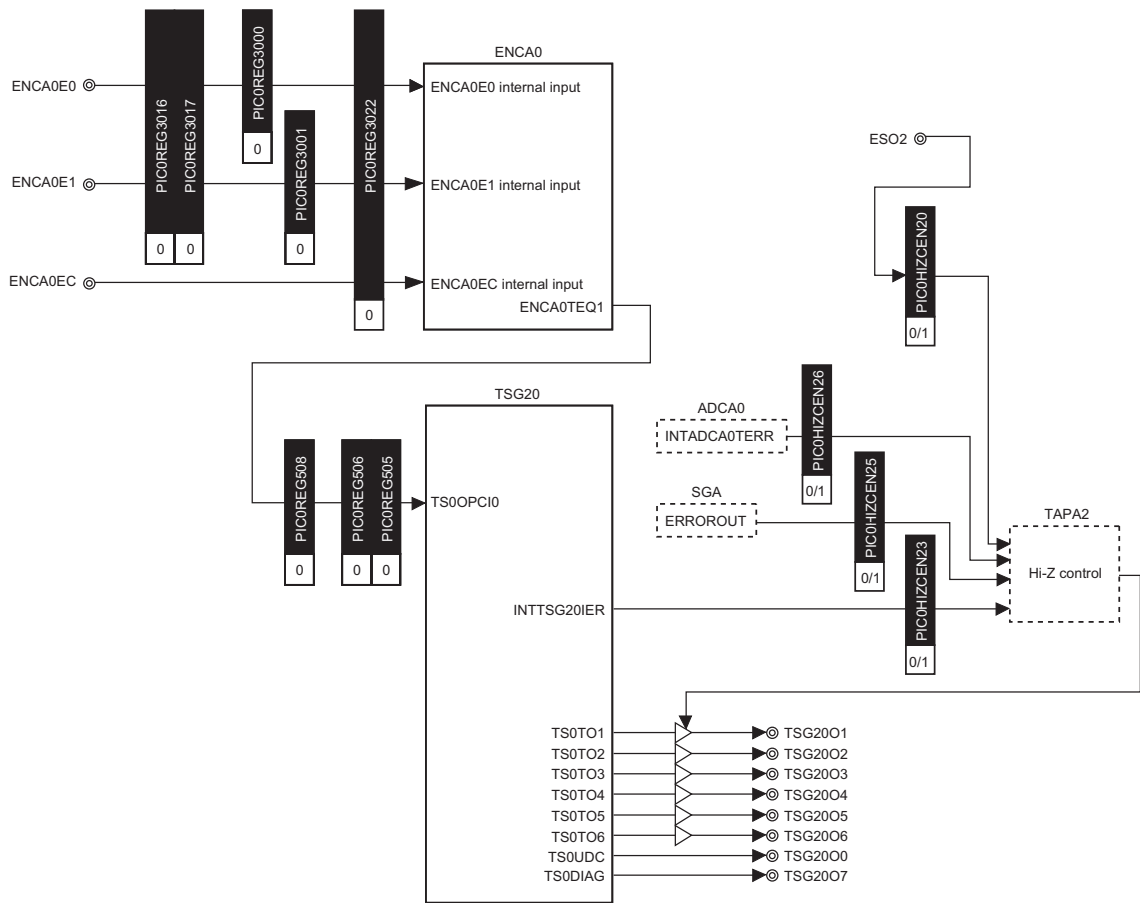

Note:
 For details of the functions in the dashed-line frames, see the sections of the following functions:
 - ADCA0: AD converter function
 - SGA: Safety guardian function
 - TAPA2: Timer output Hi-Z control function

Figure 24-27 Block Diagram of Timer Configuration 1

24.4.6.3 Registers

(1) Timer I/O Control Register 30 (PIC0REG30)

PIC0REG30 is a 32-bit register that selects the timer input signal to control the two-phase encoder.

Access This register can be read/written in 32-bit units.

Address FF81 C0E8_H

Initial value 0000 0000_H

This register is initialized by any reset.

31	30	29	28	27	26	25	24
0	0	0	0	0	0	0	0
R	R	R	R	R	R	R	R
23	22	21	20	19	18	17	16
0	PIC0REG3022	0	0	0	0	PIC0REG3017	PIC0REG3016
R	R/W	R	R	R	R	R/W	R/W
15	14	13	12	11	10	9	8
0	0	0	0	0	0	0	0
R	R	R	R	R	R	R	R
7	6	5	4	3	2	1	0
0	0	0	0	0	0	PIC0REG3001	PIC0REG3000
R	R	R	R	R	R	R/W	R/W

Table 24-32 PIC0REG30 Contents

Bit Position	Bit Name	Function									
22	PIC0REG3022	Selects the input pin of the ENCA0 timer (internal input of the ENCA0E0 and ENCA0E1). 0: A signal selected by the PIC0REG3000 bit (ENCA0E0 internal input) and the PIC0REG3001 bit (ENCA0E1 internal input) 1: Setting is prohibited.									
17,16	PIC0REG3017, PIC0REG3016	Selects the input of the ENCA0 timer (internal input of the ENCA0E0 and ENCA0E1). <table border="1" data-bbox="571 548 1385 721"> <thead> <tr> <th>PIC0REG3017</th> <th>PIC0REG3016</th> <th>Input Signal</th> </tr> </thead> <tbody> <tr> <td>0</td> <td>0</td> <td>Input of the ENCA0E0 and ENCA0E1 (ENCA0 timer)</td> </tr> <tr> <td colspan="2">Other than the above</td> <td>Setting prohibited</td> </tr> </tbody> </table>	PIC0REG3017	PIC0REG3016	Input Signal	0	0	Input of the ENCA0E0 and ENCA0E1 (ENCA0 timer)	Other than the above		Setting prohibited
PIC0REG3017	PIC0REG3016	Input Signal									
0	0	Input of the ENCA0E0 and ENCA0E1 (ENCA0 timer)									
Other than the above		Setting prohibited									
1	PIC0REG3001	Selects the signal of the ENCA0E1 internal input. 0: Input the signal selected by the PIC0REG3017 and PIC0REG3016 bits. 1: Setting is prohibited.									
0	PIC0REG3000	Selects the signal of the ENCA0E0 internal input. 0: Input the signal selected by the PIC0REG3017 and PIC0REG3016 bits. 1: Setting is prohibited.									

Caution The bit might be defined to 0 by other timer connection functions. In that case, apply the bit definition of the corresponding timer connection function.

(2) Timer I/O Control Register 50 (PIC0REG50)

PIC0REG50 selects the timer input signal to control the two-phase encoder.

Access This register can be read/written in 8-bit units.

Address FF81 C0F8_H

Initial value 0000_H

This register is initialized by any reset.

15	14	13	12	11	10	9	8
0	0	0	0	0	0	0	PIC0REG508
R	R	R	R	R	R	R	R/W
7	6	5	4	3	2	1	0
0	PIC0REG506	PIC0REG505	0	0	0	0	0
R	R/W	R/W	R	R	R	R	R

Table 24-33 PIC0REG50 Contents

Bit Position	Bit Name	Function									
8	PIC0REG508	Selects the target for input of the TSG20TSTOPC0 signal for the TSG20 timer. 0: Inputs ENCA0TEQ1 (ENCA0 timer) 1: Setting is prohibited.									
6 5	PIC0REG506, PIC0REG505	Selects the signal to be input to TS0OPCI0. <table border="1"> <thead> <tr> <th>PIC0REG506</th><th>PIC0REG505</th><th>Input Signal</th></tr> </thead> <tbody> <tr> <td>0</td><td>0</td><td>ENCA0TEQ1 input (ENCA0 timer)</td></tr> <tr> <td colspan="2">Other than the above</td><td>Setting is prohibited.</td></tr> </tbody> </table>	PIC0REG506	PIC0REG505	Input Signal	0	0	ENCA0TEQ1 input (ENCA0 timer)	Other than the above		Setting is prohibited.
PIC0REG506	PIC0REG505	Input Signal									
0	0	ENCA0TEQ1 input (ENCA0 timer)									
Other than the above		Setting is prohibited.									

Caution The bit might be defined to 0 by other timer connection functions. In that case, apply the bit definition of the corresponding timer connection function.

(3) Hi-Z Output Control Register 2 (PIC0HIZCEN2)

PIC0HIZCEN2 selects the input signal to control Hi-Z output.

Access This register can be read/written in 8-bit units.

Address FF81 C088_H

Initial value 00_H

This register is initialized by any reset.

7	6	5	4	3	2	1	0
0	PIC0HIZ CEN26	PIC0HIZ CEN25	0	PIC0HIZ CEN23	0	0	PIC0HIZ CEN20
R	R/W	R/W	R	R/W	R	R	R/W

Table 24-34 PIC0HIZCEN2 Contents

Bit Position	Bit Name	Function
6	PIC0HIZCEN26	Enables or disables Hi-Z output control with the INTADCA0TERR interrupt signal. 0: Disable 1: Enable
5	PIC0HIZCEN25	Enables or disables Hi-Z output control with the ERROROUT signal. 0: Disable 1: Enable
3	PIC0HIZCEN23	Enables or disables Hi-Z output control with the INTTSG20IER interrupt signal. 0: Disable 1: Enable
0	PIC0HIZCEN20	Enables or disables Hi-Z output control with the ESO2 pin input. 0: Disable 1: Enable

Caution The bit might be defined to 0 by other timer connection functions. In that case, apply the bit definition of the corresponding timer connection function.

24.4.6.4 Example of Operation

By setting an arbitrary encoder count value to the compare value (ENCA0CCR1) of the ENCA0 timer and enabling compare match interrupt (INTENCA011) of the ENCA0 timer as the trigger of the pattern switch of timer TSG20, the control of TSG20 output can be achieved.

In this control method, the encoder counter is cleared by a compare match of ENCA0CCR0 with the ENCA0 timer value.

It is necessary to set compare value (ENCA0CCR1) at each pattern switch (each INTENCA011 interrupt). It is necessary to match the initial output pattern of timer TSG20 to the set value of the compare register (ENCA0CCR1) of the ENCA0 timer before start because clear by Z phase input is not performed. Switching between normal and reverse rotations of output patterns should be set with the TS0PSC bit in TS0OPT0.

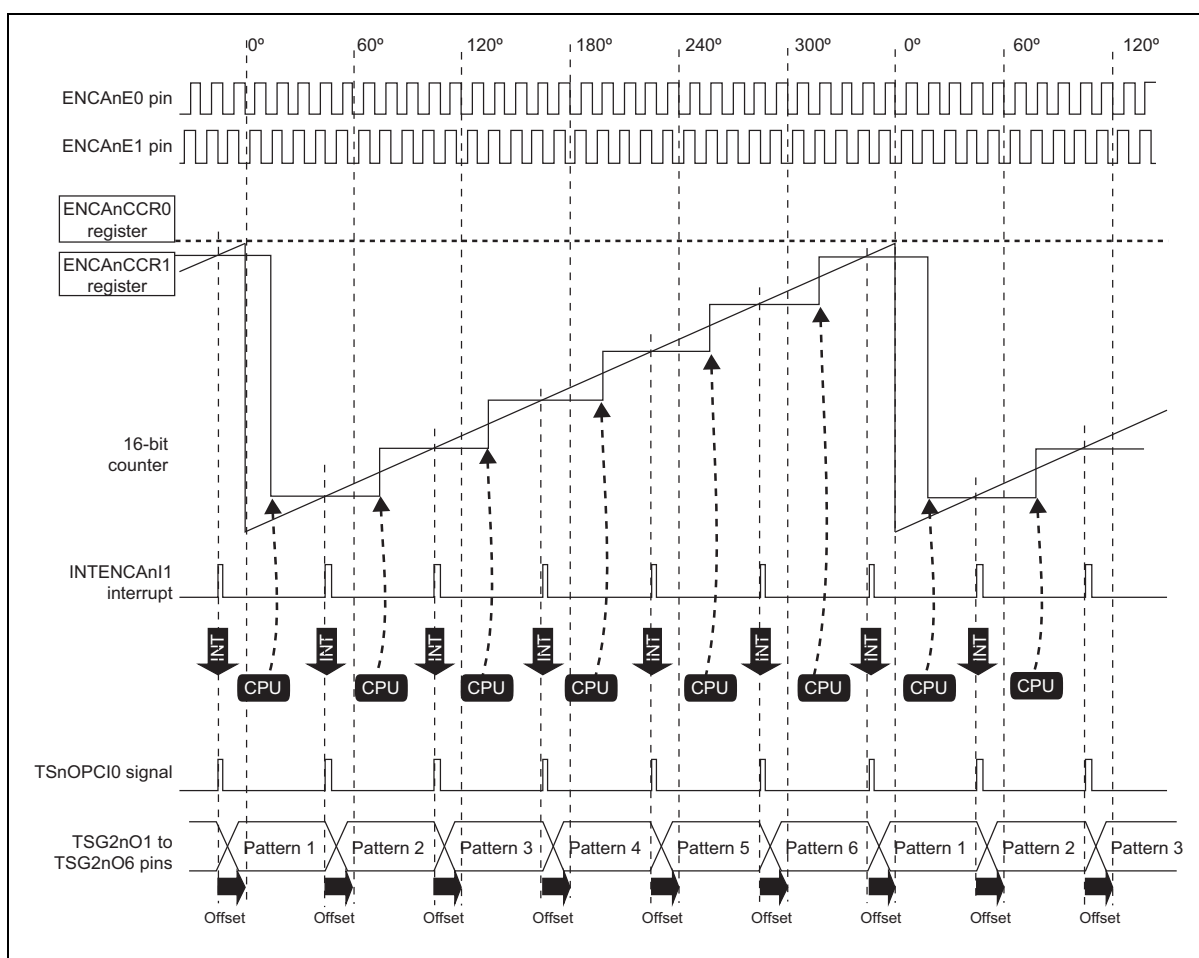

Figure 24-28 Operation Example of Control Method 1 at Up Count

Note ▲ : Write access with CPU

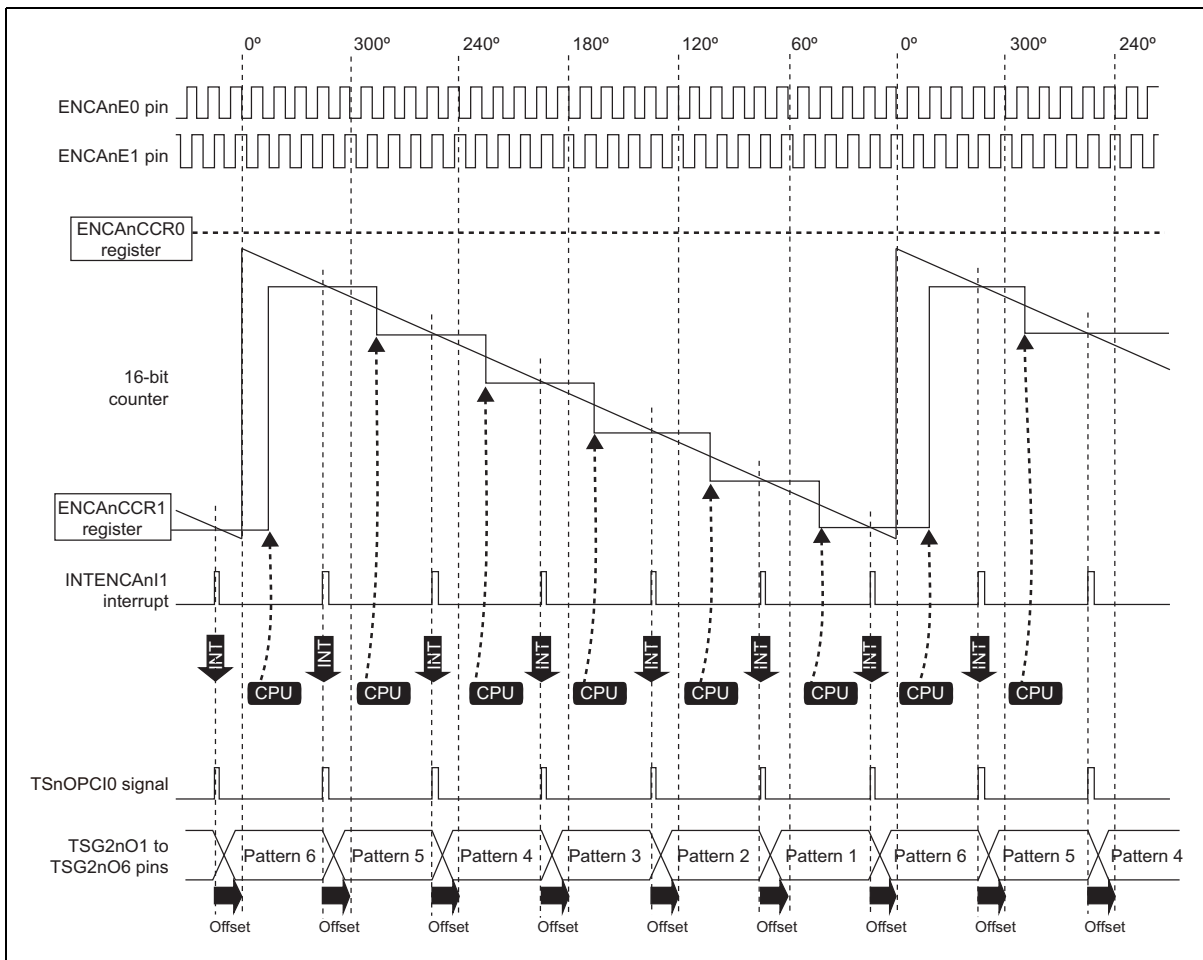

Figure 24-29 Operation Example of Control Method 1 at Down Count

Note ▲ : Write access with CPU

24.4.6.5 Operation Flow

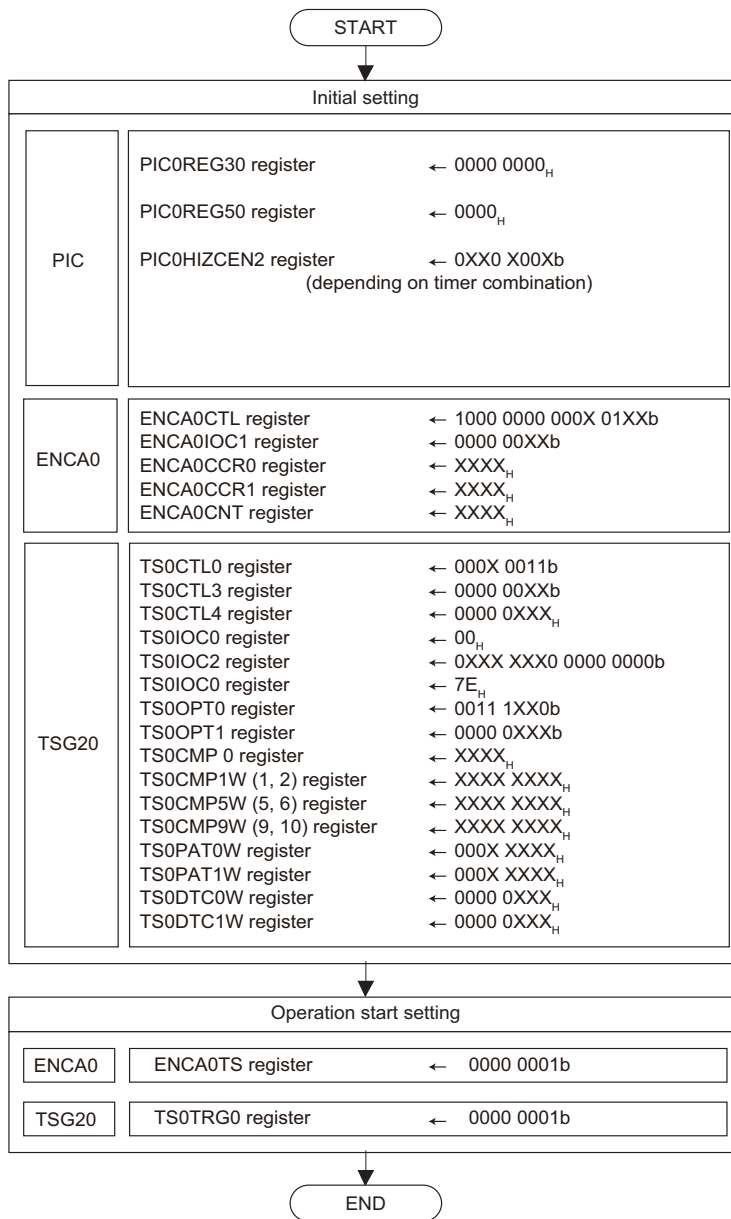

Figure 24-30 Initial Setting and Operation Start Flow

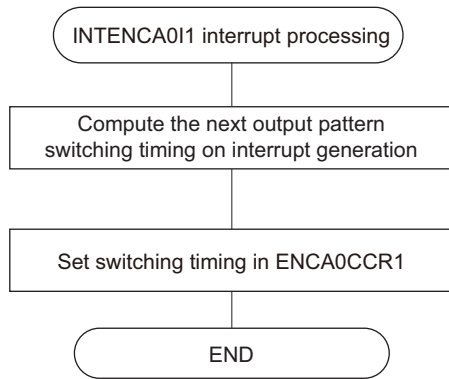

Figure 24-31 ENCA0CCR1 Rewrite Flow during Operation

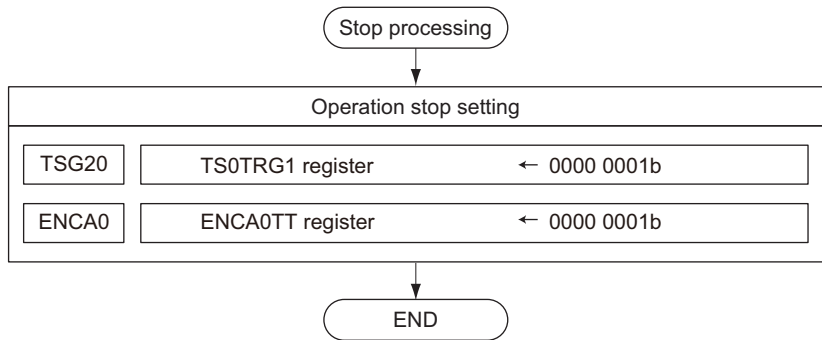

Figure 24-32 Operation Stop Flow

24.4.6.6 Function Setting

The following table shows the register settings.

Register bits not listed in the table are used with the initial values.

Table 24-35 ENCA0 Setting

Function	Register	Bit Position	Bit Name	Set Value	Note
ENCA0	ENCA0CTL	15	ENCA0CME	1	Enables or disables compare match interrupt detection mask.
		14	ENCA0MCS	0	Selects a cancelation trigger of compare match interrupt detection mask.
		9	ENCA0CRM1	0	Selects the ENCA0CCR1 function (capture/compare)
		8	ENCA0CRM0	0	Selects the ENCA0CCR0 function (capture/compare)
		7	ENCA0CTS	0	Selects trigger of capture operation of ENCA0CCR1
		4	ENCA0LDE	1	Enables or disables reload operation when underflow is generated.
		3	ENCA0ECM1	0	Enables or disables clearing of the counter on compare match of ENCA0CCR1.
		2	ENCA0ECM0	1	Enables or disables clearing of the counter on compare match of ENCA0CCR0.
		1, 0	ENCA0UDS1, ENCA0UDS0	Don't care	Selects the counter up/down control by ENCA0E0/ENCA0E1.
	ENCA0IOC1	7	ENCA0SCE	0	Enables the special encoder clear.
		6	ENCA0ZCL	0	Selects the clear level of Z phase for a special encoder clear.
		5	ENCA0BCL	0	Selects the clear level of B phase for a special encoder clear.
		4	ENCA0ACL	0	Selects the clear level of A phase for a special encoder clear.
		3, 2	ENCA0ECS1 ENCA0ECS0	0	Selects encoder clear input (Z phase) edge.
		1, 0	ENCA0EIS1 ENCA0EIS0	Don't care	Selects encoder input (A and B phase) edge.
	ENCA0CCR0	-	-	Don't care	Compare register Sets a compare value.
	ENCA0CCR1	-	-	Don't care	Compare register Sets a compare value (should be rewritten during timer operation).
	ENCA0CNT	-	-	Don't care	Timer counter register

Table 24-36 TSG20 Setting (1/2)

Function	Register	Bit Position	Bit Name	Set Value	Note
TSG20	TS0CTL0	4	TS0DWD	Don't care	Selects the diag output pulse width.
		1, 0	TS0MD1, TS0MD0	1, 1	Selects operating mode (120-DC).
	TS0CTL3	1	TS0RIA	Don't care	Selects the reload timing of the compare register.
		0	TS0RMC	Don't care	Selects the transfer timing of the compare register.
	TS0CTL4	8	TS0PRE	Don't care	Enables or disables peak reload timing.
		7	TS0VRE	Don't care	Enables or disables valley reload timing.
		6	TS0PIE	0	Enables or disables generation of the peak interrupt.
		5	TS0VIE	0	Enables or disables generation of the valley interrupt.
		4 to 0	TS0RCC4, TS0RCC3, TS0RCC2, TS0RCC1, TS0RCC0	0, 0, 0, 0, 0	Sets the thinning out rate of reload timing and interrupt.
	TS0IOC0	6	TS0TOE6	0/1	Enables or disables rewriting of the TS0OL6 and TS0TO6 bits in TS0IOC2.
		5	TS0TOE5	0/1	Enables or disables rewriting of the TS0OL5 and TS0TO5 bits in TS0IOC2.
		4	TS0TOE4	0/1	Enables or disables rewriting of the TS0OL4 and TS0TO4 bits in TS0IOC2.
		3	TS0TOE3	0/1	Enables or disables rewriting of the TS0OL3 and TS0TO3 bits in TS0IOC2.
		2	TS0TOE2	0/1	Enables or disables rewriting of the TS0OL2 and TS0TO2 bits in TS0IOC2.
		1	TS0TOE1	0/1	Enables or disables rewriting of the TS0OL1 and TS0TO1 bits in TS0IOC2.
	TS0IOC2	14	TS0OL6	Don't care	Selects an active level of the TSG20O6 output.
		13	TS0OL5	Don't care	Selects an active level of the TSG20O5 output.
		12	TS0OL4	Don't care	Selects an active level of the TSG20O4 output.
		11	TS0OL3	Don't care	Selects an active level of the TSG20O3 output.
		10	TS0OL2	Don't care	Selects an active level of the TSG20O2 output.
	TS0OPT0	9	TS0OL1	Don't care	Selects an active level of the TSG20O1 output.
		6	TS0SOC	0	Selects the control of the timer output with software.
		5	TS0STE	1	Enables or disables the control with the pattern output trigger.
		4	TS0POT	1	Selects the pattern output trigger. Selects either the output pattern switching by the external pattern input pin (TSG20PTS10 to TSG20PTS12) or output switching by the TS0OPCI1 and TS0OPCI0 rising edge as the pattern output trigger.
		3	TS0PSS	1	Selects the pattern output order switching method. The pattern output order is switched with TS0PSC.
		2	TS0IDC	Don't care	Selects the direction of the motor rotation.
		1	TS0PSC	Don't care	Selects the order of the timer output pattern during semi-automatic cruise control.
	TS0OPT1	2 to 0	TS0SPC2- TS0SPC0	Don't care	Sets the timer output pattern in software output function mode.

Table 24-36 TSG20 Setting (2/2)

Function	Register	Bit Position	Bit Name	Set Value	Note
TSG20	TS0CMP0	-	-	Don't care	Compare register Sets the PWM period.
	TS0CMP1W	-	-	Don't care	Compare register Sets the compare value.
	TS0CMP5W	-	-	Don't care	Compare register Sets the compare value.
	TS0CMP9W	-	-	Don't care	Compare register Sets the compare value.
	TS0PAT0W	-	-	Don't care	Pattern register Sets the output pattern.
	TS0PAT1W	-	-	Don't care	Pattern register Sets the output pattern.
	TS0DTC0W	-	-	Don't care	Dead time set register Sets the dead time value.
	TS0DTC1W	-	-	Don't care	Dead time set register Sets the dead time value.

Table 24-37 PIC Setting

Function	Register	Bit Position	Bit Name	Set Value	Note
PIC	PIC0REG30	22	PIC0REG3022	See the block diagram.	Selects the ENCA0E0/ENCA0E1/ENCA0EC pin input.
		17,16	PIC0REG3017, PIC0REG3016	See the block diagram.	Selects the ENCA0E0/ENCA0E1 pin input.
		1	PIC0REG3001	See the block diagram.	Selects the ENCA0E1 pin input.
		0	PIC0REG3000	See the block diagram.	Selects the ENCA0E0 pin input.
	PIC0REG50	8	PIC0REG508	See the block diagram.	Selects the ENCA0TEQ1 signal.
		6, 5	PIC0REG506, PIC0REG505	See the block diagram.	Selects the ENCA0TEQ1 signal.
	PIC0HIZCEN2	6	PIC0HIZCEN26	See the block diagram.	Enables or disables the INTADC0TERR interrupt as Hi-Z control signal input.
		5	PIC0HIZCEN25	See the block diagram.	Enables or disables the ERROROUT signal as Hi-Z control signal input.
		3	PIC0HIZCEN23	See the block diagram.	Enables or disables the INTTSG20IER interrupt as Hi-Z control signal input.
		0	PIC0HIZCEN20	See the block diagram.	Enables or disables the ESO2 pin input as Hi-Z control signal input.

24.4.7 Two-Phase Encoder Control Function (Control Method 2)

24.4.7.1 Functional Overview

This function allows changing the TSG20 output patterns using the two-phase encoder (ENCA0 timer). The output patterns can also be switched with the advance and retard control.

24.4.7.2 Configuration

Configuration/Timer Function	ENCA	TSG2	TAPA
Timer configuration	ENCA0	TSG20	TAPA2

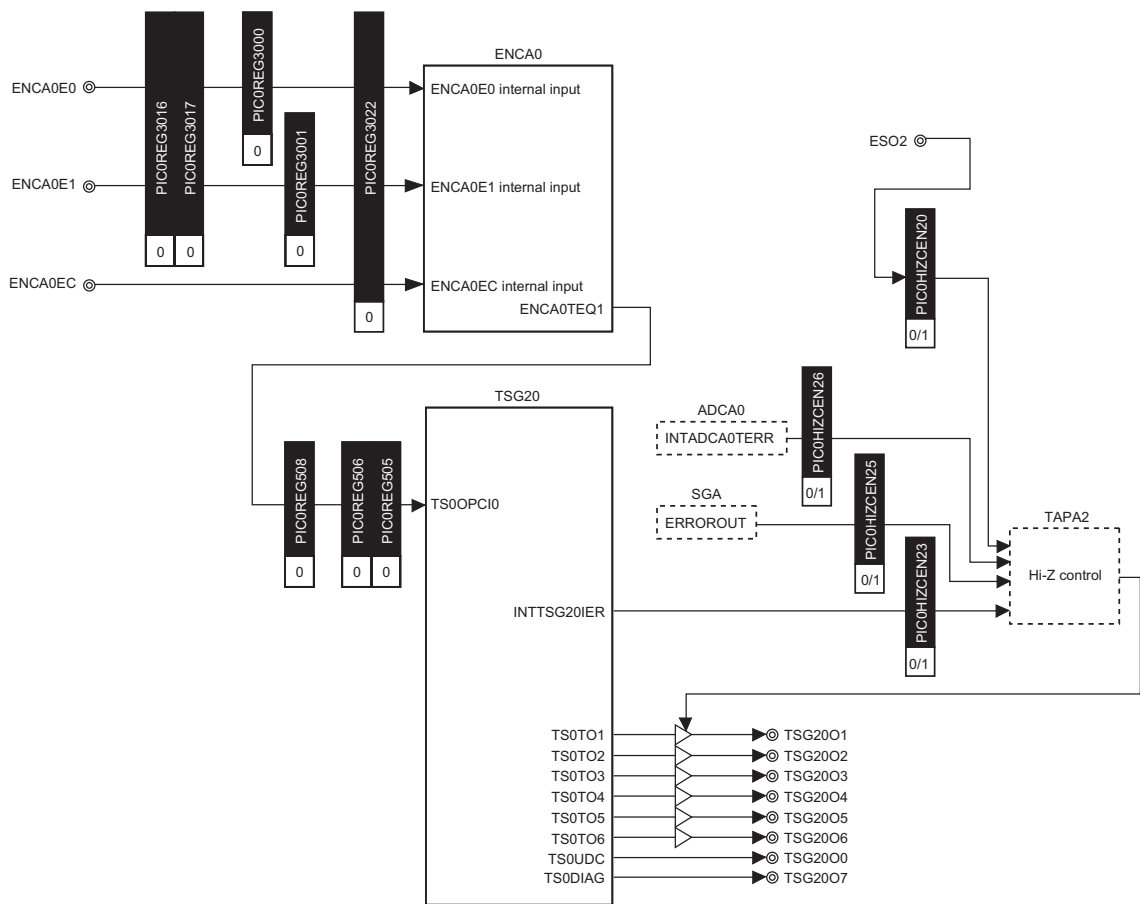

Note:
 For details of the functions in the dashed-line frames, see the sections of the following functions:
 - ADCA0: AD converter function
 - SGA: Safety guardian function
 - TAPA2: Timer output Hi-Z control function

Figure 24-33 Block Diagram of Timer Configuration 1

24.4.7.3 Registers

(1) Timer I/O Control Register 30 (PIC0REG30)

PIC0REG30 is a 32-bit register that selects the timer input signal to control the two-phase encoder.

Access This register can be read/written in 32-bit units.

Address FF81 C0E8_H

Initial value 0000 0000_H

This register is initialized by any reset.

31	30	29	28	27	26	25	24
0	0	0	0	0	0	0	0
R	R	R	R	R	R	R	R
23	22	21	20	19	18	17	16
0	PIC0REG3022	0	0	0	0	PIC0REG3017	PIC0REG3016
R	R/W	R	R	R	R	R/W	R/W
15	14	13	12	11	10	9	8
0	0	0	0	0	0	0	0
R	R	R	R	R	R	R	R
7	6	5	4	3	2	1	0
0	0	0	0	0	0	PIC0REG3001	PIC0REG3000
R	R	R	R	R	R	R/W	R/W

Table 24-38 PIC0REG30 Contents

Bit Position	Bit Name	Function									
22	PIC0REG3022	Selects the input pin of the ENCA0 timer (internal input of the ENCA0E0 and ENCA0E1) 0: A signal selected by the PIC0REG3000 bit (ENCA0E0 internal input) and the PIC0REG3001 bit (ENCA0E1 internal input) 1: Setting is prohibited.									
17,16	PIC0REG3017, PIC0REG3016	Selects the input of the ENCA0 timer (internal input of the ENCA0E0 and ENCA0E1) <table border="1" style="margin-left: 20px;"> <thead> <tr> <th>PIC0REG3017</th> <th>PIC0REG3016</th> <th>Input Signal</th> </tr> </thead> <tbody> <tr> <td>0</td> <td>0</td> <td>Input of the ENCA0E0 and ENCA0E1 (ENCA0 timer)</td> </tr> <tr> <td colspan="2">Other than the above</td> <td>Setting is prohibited.</td> </tr> </tbody> </table>	PIC0REG3017	PIC0REG3016	Input Signal	0	0	Input of the ENCA0E0 and ENCA0E1 (ENCA0 timer)	Other than the above		Setting is prohibited.
PIC0REG3017	PIC0REG3016	Input Signal									
0	0	Input of the ENCA0E0 and ENCA0E1 (ENCA0 timer)									
Other than the above		Setting is prohibited.									
1	PIC0REG3001	Selects ENCA0 timer input. 0: ENCA0E1 pin input 1: Setting is prohibited.									
0	PIC0REG3000	Selects ENCA0 timer input. 0: ENCA0E0 pin input 1: Setting is prohibited.									

Caution The bit might be defined to 0 by other timer connection functions. In that case, apply the bit definition of the corresponding timer connection function.

(2) Timer I/O Control Register 50 (PIC0REG50)

PIC0REG50 selects the timer input signal to control the two-phase encoder.

Access This register can be read/written in 16-bit units.

Address FF81 C0F8_H

Initial value 0000_H

This register is initialized by any reset.

15	14	13	12	11	10	9	8
0	0	0	0	0	0	0	PIC0REG508
R	R	R	R	R	R	R	R/W
7	6	5	4	3	2	1	0
0	PIC0REG506	PIC0REG505	0	0	0	0	0
R	R/W	R/W	R	R	R	R	R

Table 24-39 PIC0REG50 Contents

Bit Position	Bit Name	Function									
8	PIC0REG508	Selects the target for input of the TSG20TSTOPC0 signal for the TSG20 timer. 0: Inputs ENCA0TEQ1 (ENCA0 timer) 1: Setting is prohibited.									
6 5	PIC0REG506, PIC0REG505	Selects the signal to be input to TS0OPCI0. <table border="1" style="margin-left: 20px;"> <thead> <tr> <th>PIC0REG506</th> <th>PIC0REG505</th> <th>Input Signal</th> </tr> </thead> <tbody> <tr> <td>0</td> <td>0</td> <td>ENCA0TEQ1 input (ENCA0 timer)</td> </tr> <tr> <td colspan="2">Other than the above</td> <td>Setting is prohibited.</td> </tr> </tbody> </table>	PIC0REG506	PIC0REG505	Input Signal	0	0	ENCA0TEQ1 input (ENCA0 timer)	Other than the above		Setting is prohibited.
PIC0REG506	PIC0REG505	Input Signal									
0	0	ENCA0TEQ1 input (ENCA0 timer)									
Other than the above		Setting is prohibited.									

Caution The bit might be defined to 0 by other timer connection functions. In that case, apply the bit definition of the corresponding timer connection function.

(3) Hi-Z Output Control Register 2 (PIC0HIZCEN2)

PIC0HIZCEN2 selects the input signal to control Hi-Z output.

Access This register can be read/written in 8-bit units.

Address FF81 C088_H

Initial value 00_H

This register is initialized by any reset.

7	6	5	4	3	2	1	0
0	PIC0HIZ CEN26	PIC0HIZ CEN25	0	PIC0HIZ CEN23	0	0	PIC0HIZ CEN20
R	R/W	R/W	R	R/W	R	R	R/W

Table 24-40 PIC0HIZCEN2 Contents

Bit Position	Bit Name	Function
6	PIC0HIZCEN26	Enables or disables Hi-Z output control with the INTADCA0TERR interrupt signal. 0: Disable 1: Enable
5	PIC0HIZCEN25	Enables or disables Hi-Z output control with the ERROROUT signal. 0: Disable 1: Enable
3	PIC0HIZCEN23	Enables or disables Hi-Z output control with the INTTSG20IER interrupt signal. 0: Disable 1: Enable
0	PIC0HIZCEN20	Enables or disables Hi-Z output control with the ESO2 pin input. 0: Disable 1: Enable

Caution The bit might be defined to 0 by other timer connection functions. In that case, apply the bit definition of the corresponding timer connection function.

24.4.7.4 Example of Operation

The encoder count value at which the TSG20 output pattern is switched and encoder count value which defines an offset of the output pattern switching position (advance or retard) are set in ENCA0CCR0 and ENCA0CCR1 of the ENCA0 timer, respectively. Using compare match interrupt (INTENCA0I1) of the ENCA0 timer as a trigger of the pattern switch of timer TSG20, the control of TSG20 output can be achieved.

In control method 2, the encoder counter is cleared by a compare match of ENCA0CCR0. It is not necessary to set the compare value for each interrupt, unlike in control method 1.

The ENCA0CCR1 value can be rewritten with the INTENCA0I1 interrupt. It is necessary to match the initial output pattern of TSG20 to the set value of ENCA0CCR0 before start because clear by encoder clear input is not performed. Switching between normal and reverse rotations of output patterns should be set with the TS0PSC bit in TS0OPT0.

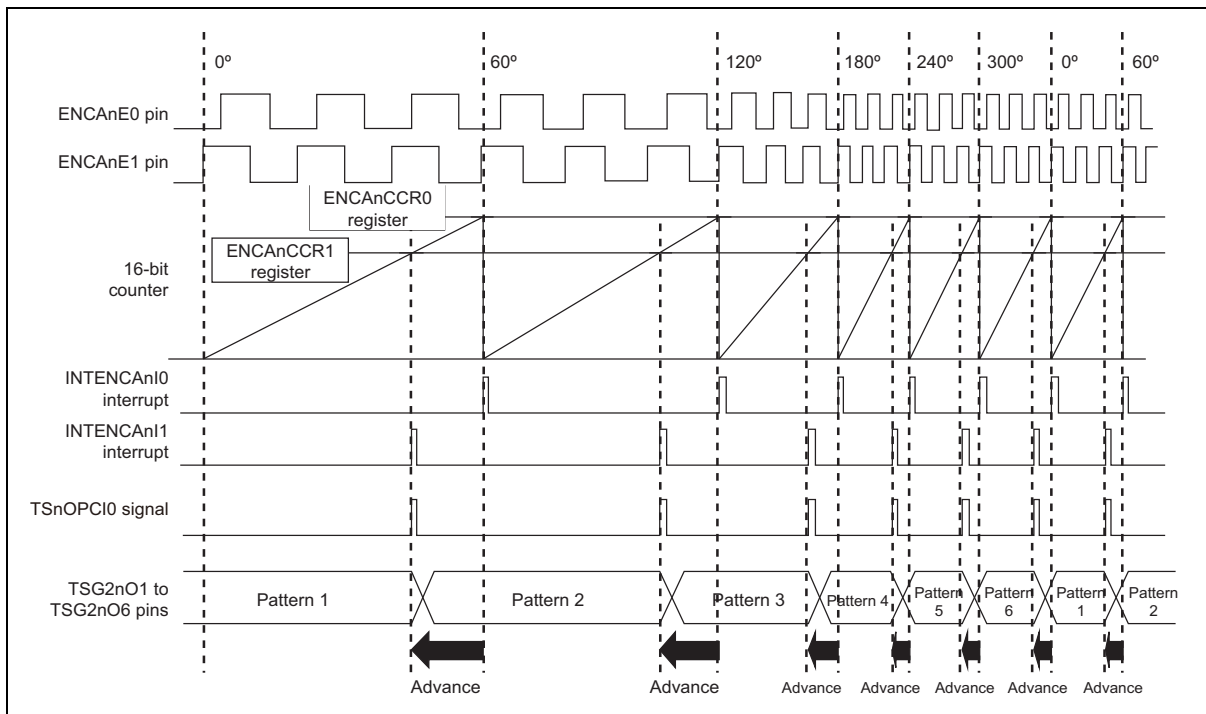

Figure 24-34 Operation Example of Control Method 2: at Advance

By advancing the output pattern switching ahead of the timing set in ENCA0CCR0, the TSG20 output pattern phase can be advanced.

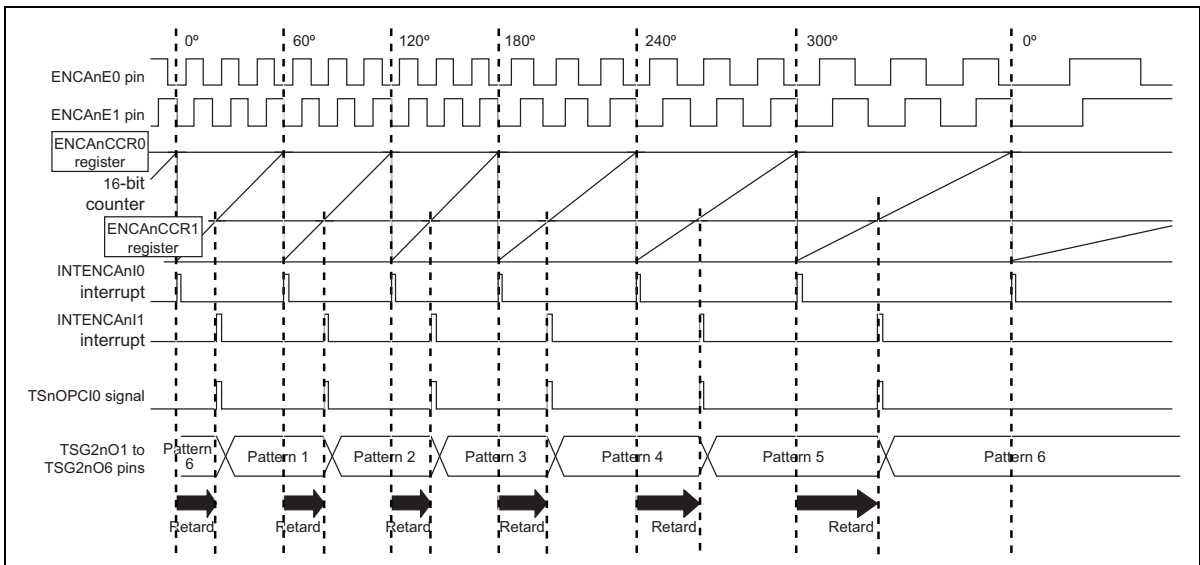

Figure 24-35 Operation Example of Control Method 2: at Retard

By delaying the output pattern switching behind the timing set in ENCAAnCCR0, the TSG2nO output pattern phase can be retarded.

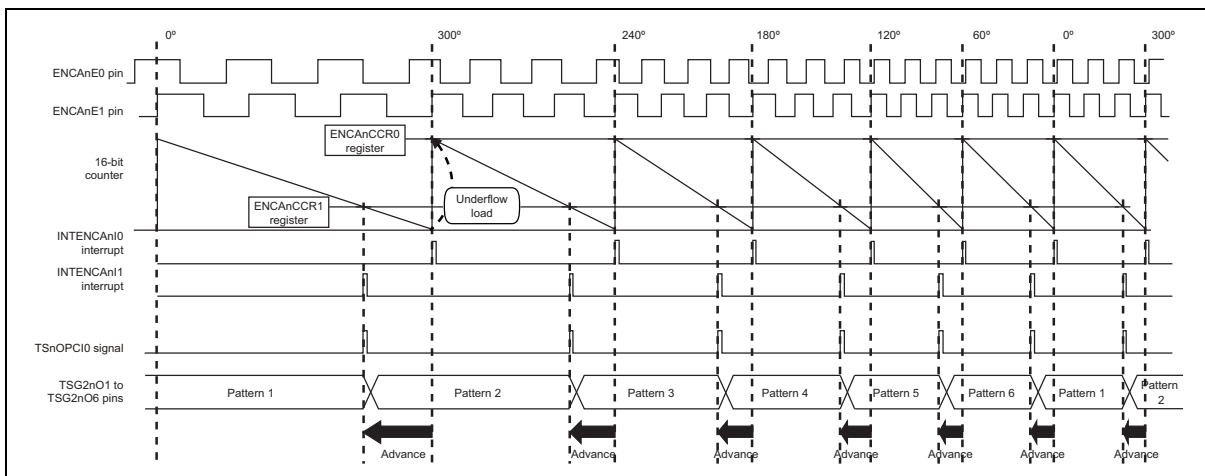

Figure 24-36 Operation Example of Control Method 2: at Down Count

24.4.7.5 Operation Flow

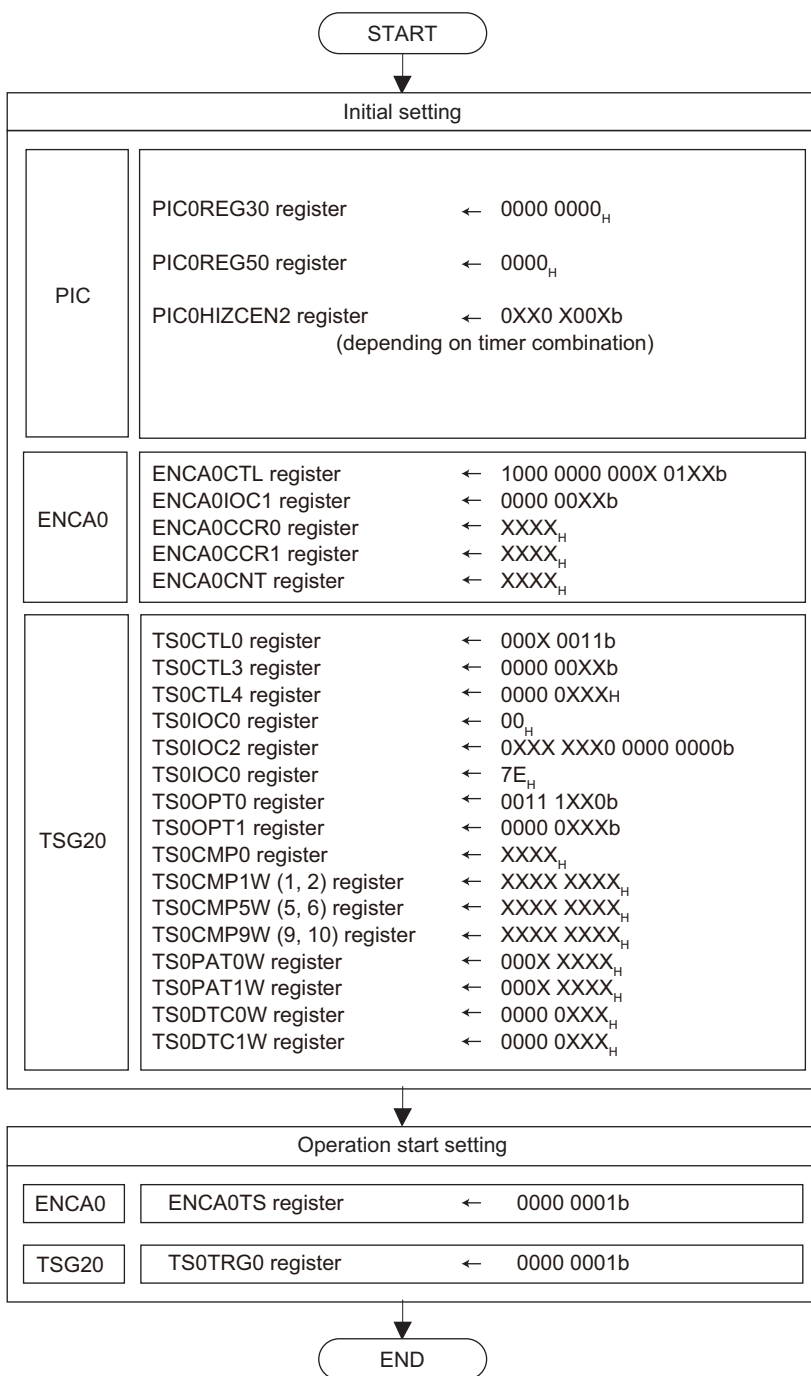

Figure 24-37 Initial Setting and Operation Start Flow

Advance processing

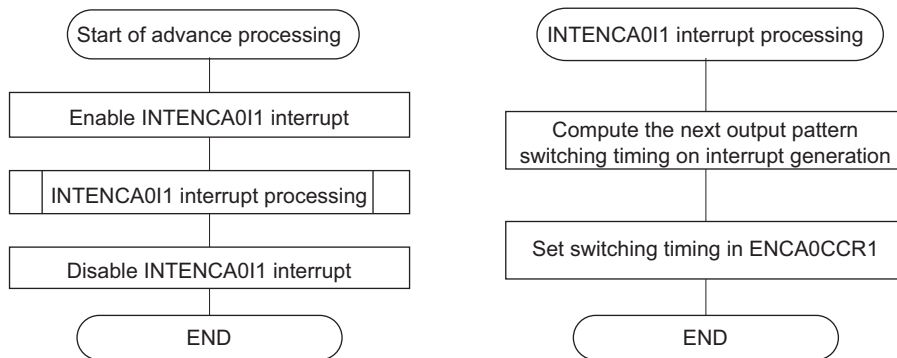

Figure 24-38 ENCA0CCR1 Rewrite Flow during Operation

Retard processing

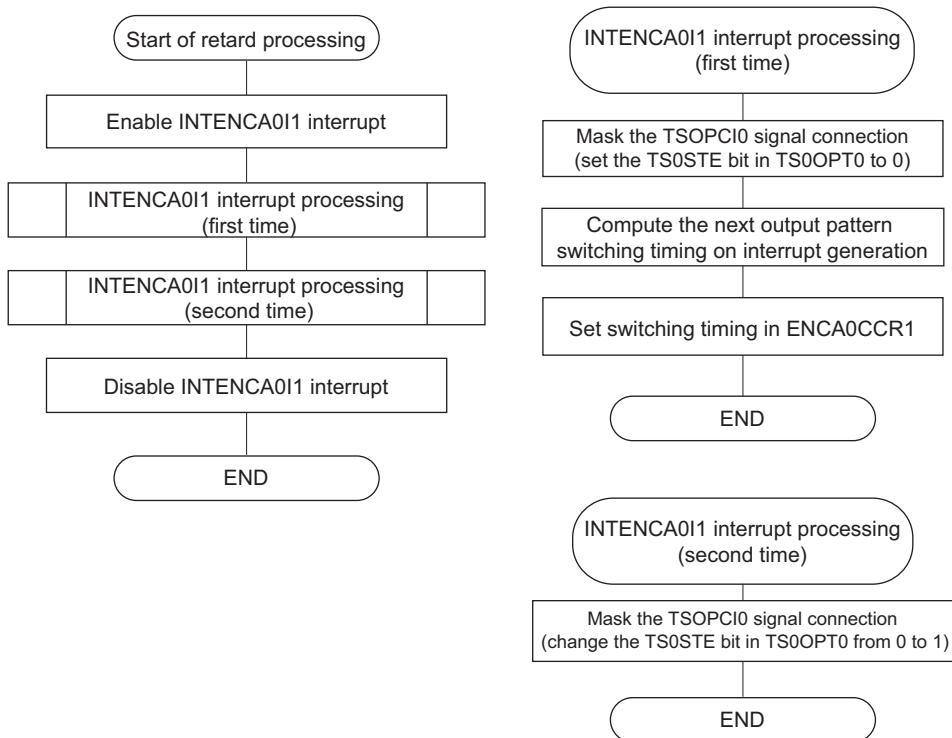

Figure 24-39 ENCA0CCR1 Rewrite Flow during Operation

Figure 24-40 Operation Stop Flow

24.4.7.6 Function Setting

Timer register settings

Register bits not listed here are used with the initial values.

Table 24-41 ENCA0 Setting

Function	Register	Bit Position	Bit Name	Set Value	Note
ENCA0	ENCA0CTL	15	ENCA0CME	1	Enables or disables compare match interrupt detection mask.
		14	ENCA0MCS	0	Selects a cancelation trigger of compare match interrupt detection mask.
		9	ENCA0CRM1	0	Selects the ENCA0CCR1 function (capture/compare)
		8	ENCA0CRM0	0	Selects the ENCA0CCR0 function (capture/compare)
		7	ENCA0CTS	0	Selects trigger of capture operation of ENCA0CCR1
		4	ENCA0LDE	1	Enables or disables reload operation when underflow is generated.
		3	ENCA0ECM1	0	Enables or disables clearing of the counter on compare match of ENCA0CCR1.
		2	ENCA0ECM0	1	Enables or disables clearing of the counter on compare match of ENCA0CCR0.
		1, 0	ENCA0UDS1, ENCA0UDS0	Don't care	Selects the counter up/down control by ENCA0E0/ ENCA0E1.
	ENCA0IOC1	7	ENCA0SCE	0	Enables the special encoder clear.
		6	ENCA0ZCL	0	Selects the clear level of Z phase for a special encoder clear.
		5	ENCA0BCL	0	Selects the clear level of B phase for a special encoder clear.
		4	ENCA0ACL	0	Selects the clear level of A phase for a special encoder clear.
		3, 2	ENCA0ECS1 ENCA0ECS0	0	Selects encoder clear input (Z phase) edge.
		1, 0	ENCA0EIS1 ENCA0EIS0	Don't care	Selects encoder input (A and B phase) edge.
	ENCA0CCR0	—	—	Don't care	Compare register Sets a compare value.
	ENCA0CCR1	—	—	Don't care	Compare register Sets a compare value.
	ENCA0CNT	—	—	Don't care	Timer counter register

Table 24-42 TSG20 Setting (1/2)

Function	Register	Bit Position	Bit Name	Set Value	Note
TSG20	TSOCTL0	4	TS0DWD	Don't care	Selects the diag output pulse width.
		1, 0	TS0MD1, TS0MD0	1, 1	Selects operating mode (120-DC).
	TSOCTL3	1	TS0RIA	Don't care	Selects the reload timing of the compare register.
		0	TS0RMC	Don't care	Selects the transfer timing of the compare register.
	TSOCTL4	8	TS0PRE	Don't care	Enables or disables peak reload timing.
		7	TS0VRE	Don't care	Enables or disables valley reload timing.
		6	TS0PIE	0	Enables or disables generation of the peak interrupt.
		5	TS0VIE	0	Enables or disables generation of the valley interrupt.
		4 to 0	TS0RCC4, TS0RCC3, TS0RCC2, TS0RCC1, TS0RCC0	0	Sets the thinning out rate of reload timing and interrupt.
		TS0IOC0	6	TS0TOE6	0/1
	5		TS0TOE5	0/1	Enables or disables rewriting of the TS0OL5 and TS0TO5 bits in TS0IOC2.
	4		TS0TOE4	0/1	Enables or disables rewriting of the TS0OL4 and TS0TO4 bits in TS0IOC2.
	3		TS0TOE3	0/1	Enables or disables rewriting of the TS0OL3 and TS0TO3 bits in TS0IOC2.
	2		TS0TOE2	0/1	Enables or disables rewriting of the TS0OL2 and TS0TO2 bits in TS0IOC2.
	1		TS0TOE1	0/1	Enables or disables rewriting of the TS0OL1 and TS0TO1 bits in TS0IOC2.
	TS0IOC2	14	TS0OL6	Don't care	Selects an active level of the TSG20O6 output.
		13	TS0OL5	Don't care	Selects an active level of the TSG20O5 output.
		12	TS0OL4	Don't care	Selects an active level of the TSG20O4 output.
		11	TS0OL3	Don't care	Selects an active level of the TSG20O3 output.
		10	TS0OL2	Don't care	Selects an active level of the TSG20O2 output.
	TS0OPT0	9	TS0OL1	Don't care	Selects an active level of the TSG20O1 output.
		6	TS0SOC	0	Selects the control of the timer output with software.
		5	TS0STE	1	Enables or disables the control with the pattern output trigger.
		4	TS0POT	1	Selects pattern output trigger. Selects either the output pattern switching by the external pattern input pin (TSG20PTSI0 to TSG20PTSI2) or output switching by the TS0OPCI1 and TS0OPCI0 rising edge as the pattern output trigger.
		3	TS0PSS	1	Selects the pattern output order switching method. The pattern output order is switched with TS0PSC.
		2	TS0IDC	Don't care	Selects the direction of the motor rotation.
	TS0OPT1	1	TS0PSC	Don't care	Selects the order of the timer output pattern during semi-automatic cruise control.
			TS0SPC2- TS0SPC0	Don't care	Sets the timer output pattern in software output function mode.

Table 24-42 TSG20 Setting (2/2)

Function	Register	Bit Position	Bit Name	Set Value	Note
TSG20	TSOCMP0	-	-	Don't care	Compare register Sets the PWM period.
	TSOCMP1W	-	-	Don't care	Compare register Sets the compare value.
	TSOCMP5W	-	-	Don't care	Compare register Sets the compare value.
	TSOCMP9W	-	-	Don't care	Compare register Sets the compare value.
	TSOPAT0W	-	-	Don't care	Pattern register Sets the output pattern.
	TSOPAT1W	-	-	Don't care	Pattern register Sets the output pattern.
	TSODTC0W	-	-	Don't care	Dead time set register Sets the dead time value.
	TSODTC1W	-	-	Don't care	Dead time set register Sets the dead time value.

Table 24-43 PIC Setting

Function	Register	Bit Position	Bit Name	Set Value	Note
PIC	PIC0REG30	22	PIC0REG3022	See the block diagram	Selects the ENCA0E0/ENCA0E1/ ENCA0EC pin input.
		17,16	PIC0REG3017, PIC0REG3016	See the block diagram	Selects the ENCA0E0/ENCA0E1 pin input.
		1	PIC0REG3001	See the block diagram	Selects the ENCA0E1 pin input.
		0	PIC0REG3000	See the block diagram	Selects the ENCA0E0 pin input.
	PIC0REG50	8	PIC0REG508	See the block diagram	Selects the ENCA0TEQ1 signal.
		6, 5	PIC0REG506, PIC0REG505	See the block diagram	Selects the ENCA0TEQ1 signal.
	PIC0HIZCEN2	6	PIC0HIZCEN26	See the block diagram	Enables or disables the INTADC0TERR interrupt as Hi-Z control signal input.
		5	PIC0HIZCEN25	See the block diagram	Enables or disables the ERROROUT signal as Hi-Z control signal input.
		3	PIC0HIZCEN23	See the block diagram	Enables or disables the INTTSG20IER interrupt as Hi-Z control signal input.
		0	PIC0HIZCEN20	See the block diagram	Enables or disables the ESO2 pin input as Hi-Z control signal input.

24.4.8 Three-Phase Encoder Control Function

24.4.8.1 Functional Overview

This function allows connecting the signal input to the TSG20PTS10 to TSG20PTS12 pins to the ENCA0 timer to perform count operation.

24.4.8.2 Configuration

Configuration/ Timer Function	ENCA	TSG2
Timer configuration	ENCA0	TSG20

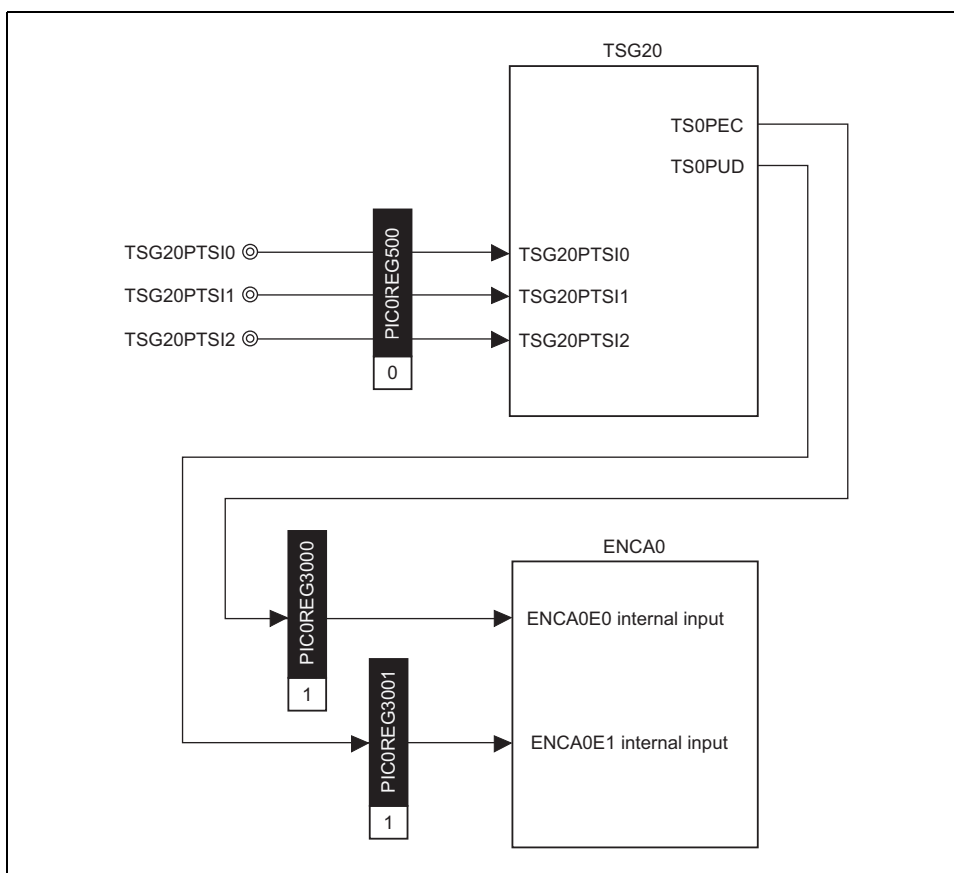

Figure 24-41 Block Diagram of Timer Configuration 1

24.4.8.3 Registers

(1) Timer I/O Control Register 30 (PIC0REG30)

PIC0REG30 is a 32-bit register that selects the timer input signal to control the three-phase encoder.

Access This register can be read/written in 32-bit units.

Address FF81 C0E8_H

Initial value 0000 0000_H

This register is initialized by any reset.

31	30	29	28	27	26	25	24
0	0	0	0	0	0	0	0
R	R	R	R	R	R	R	R
23	22	21	20	19	18	17	16
0	0	0	0	0	0	0	0
R	R	R	R	R	R	R	R
15	14	13	12	11	10	9	8
0	0	0	0	0	0	0	0
R	R	R	R	R	R	R	R
7	6	5	4	3	2	1	0
0	0	0	0	0	0	PIC0REG3001	PIC0REG3000
R	R	R	R	R	R	R/W	R/W

Table 24-44 PIC0REG30 Contents

Bit Position	Bit Name	Function
1	PIC0REG3001	Selects the TS0PUD signal of TSG20 and selects ENCA0 timer input. 0: Setting is prohibited. 1: TS0PUD signal input of TSG20
0	PIC0REG3000	Selects the TS0PUD signal of TSG20 and selects ENCA0 timer input. 0: Setting is prohibited. 1: TS0PUD signal input of TSG20

Caution The bit might be defined to 0 by other timer connection functions. In that case, apply the bit definition of the corresponding timer connection function.

(2) Timer I/O Control Register 50 (PIC0REG50)

PIC0REG50 is an 16-bit register that selects the timer input signal to control the three-phase encoder.

Access This register can be read/written in 16-bit units.

Address FF81 C0F8_H

Initial value 00_H

This register is initialized by any reset.

15	14	13	12	11	10	9	8
0	0	0	0	0	0	0	0
R	R	R	R	R	R	R	R
7	6	5	4	3	2	1	0
0	0	0	0	0	0	0	PIC0REG50
R	R	R	R	R	R	R	R/W

Table 24-45 PIC0REG50 Contents

Bit Position	Bit Name	Function
0	PIC0REG500	Selects TSG20PTSI0 to TSG20PTSI2 pin input. 0: TSG20PTSI0 to TSG20PTSI2 pins are selected. 1: Setting is prohibited.

Caution The bit might be defined to 0 by other timer connection functions. In that case, apply the bit definition of the corresponding timer connection function.

24.4.8.4 Example of Operation

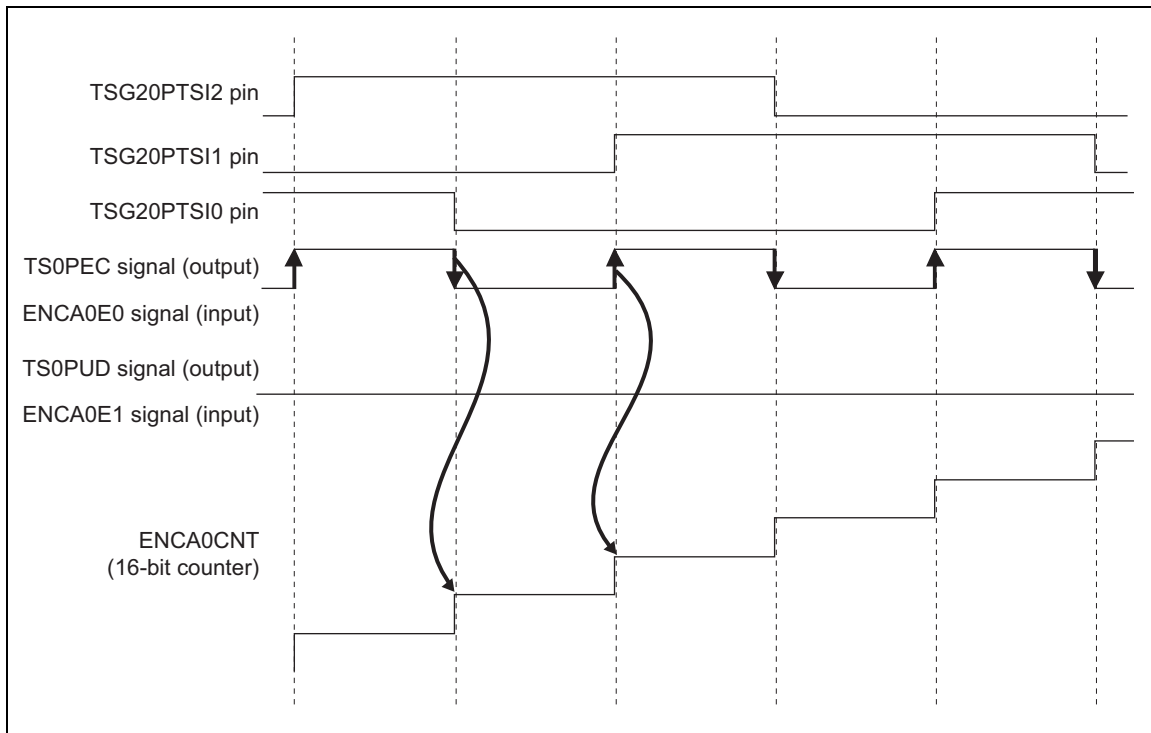

Figure 24-42 Operation Example of Three-Phase Encoder Function

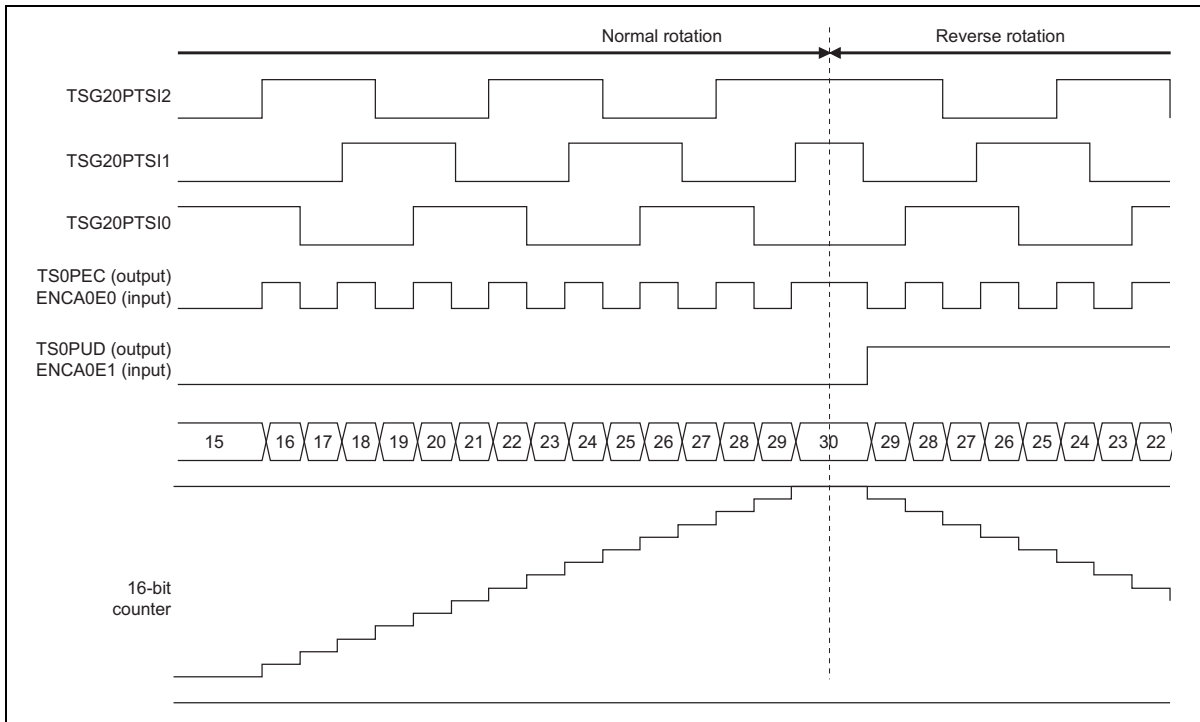

Figure 24-43 Example of Normal Rotation/Reverse Rotation using Three-Phase Encoder Function

Caution If noise is generated on the TSG20PTS12 to TSG20PTS10 pins, the 16-bit counter (ENCA0CNT) erroneously counts the noise edges.

24.4.8.5 Operation Flow

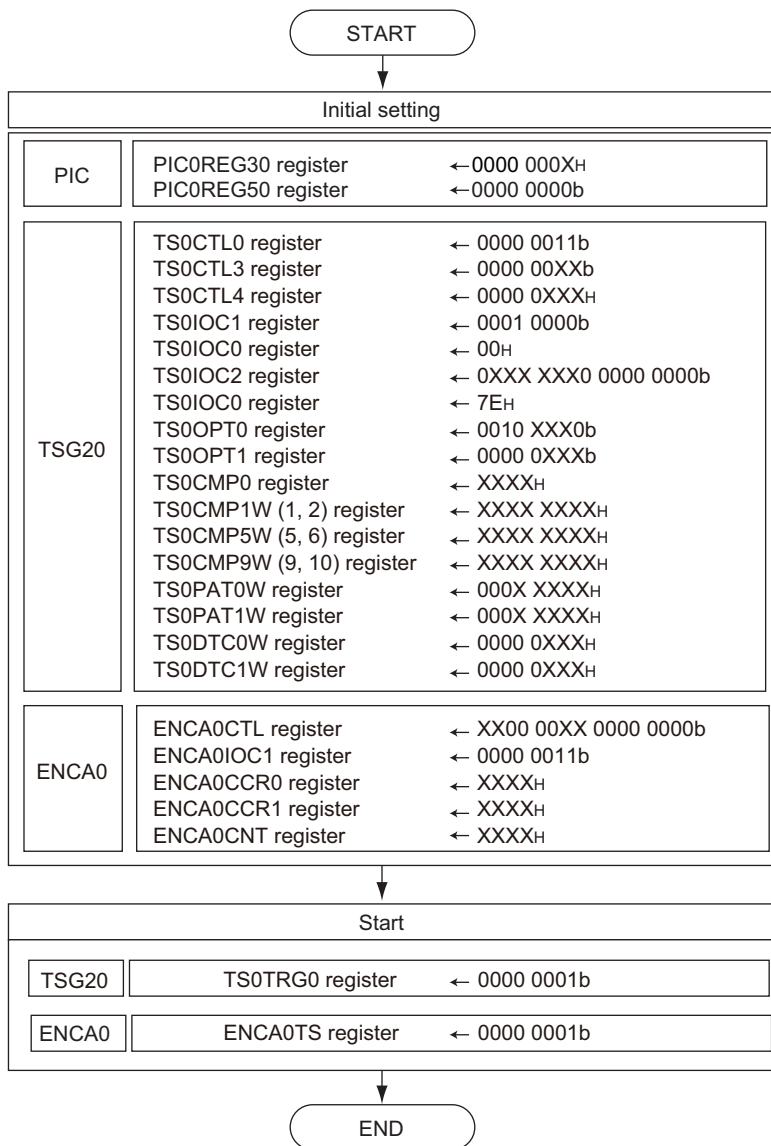

Figure 24-44 Initial Setting and Operation Start Flow

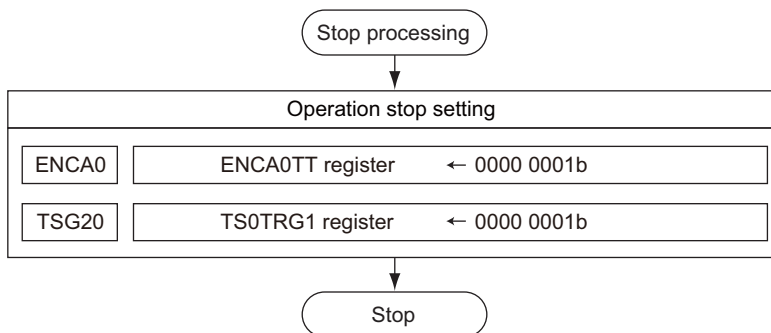

Figure 24-45 Operation Stop Flow

24.4.8.6 Function Setting

The following tables show the register settings.

Register bits not listed in the tables are used with the initial values.

Table 24-46 ENCA0 Setting

Function	Register	Bit Position	Bit Name	Set Value	Note
ENCA0	ENCA0CTL	15	ENCA0CME	Don't Care	Enables or disables compare match interrupt detection mask.
		14	ENCA0MCS	Don't Care	Selects a cancelation trigger of compare match interrupt detection mask.
		9	ENCA0CRM1	Don't Care	Selects the ENCA0CCR1 function (capture/compare)
		8	ENCA0CRM0	Don't Care	Selects the ENCA0CCR0 function (capture/compare)
		7	ENCA0CTS	0	Selects trigger of capture operation of ENCA0CCR1
		4	ENCA0LDE	0	Enables or disables reload operation when underflow is generated.
		3	ENCA0ECM1	0	Enables or disables clearing of the counter on compare match of ENCA0CCR1.
		2	ENCA0ECM0	0	Enables or disables clearing of the counter on compare match of ENCA0CCR0.
		1, 0	ENCA0UDS1, ENCA0UDS0	0, 0	Selects the counter up/down control by ENCA0E0/ ENCA0E1.
	ENCA0IOC1	7	ENCA0SCE	0	Enables the special encoder clear.
		6	ENCA0ZCL	0	Selects the clear level of Z phase for a special encoder clear.
		5	ENCA0BCL	0	Selects the clear level of B phase for a special encoder clear.
		4	ENCA0ACL	0	Selects the clear level of A phase for a special encoder clear.
		3, 2	ENCA0ECS1 ENCA0ECS0	0, 0	Selects encoder clear input (Z phase) edge.
		1, 0	ENCA0EIS1 ENCA0EIS0	1, 1	Selects encoder input (A and B phase) edge.
	ENCA0CCR0	-	-	Don't Care	Compare register Sets a compare value.
	ENCA0CCR1	-	-	Don't Care	Compare register Sets a compare value.
	ENCA0CNT	-	-	Don't Care	Timer counter register

Table 24-47 TSG20 Setting

Function	Register	Bit Position	Bit Name	Set Value	Note
TSG20	TS0CTL0	1,	TS0MD1, TS0MD0	1,	Selects operating mode (120-DC).
		0		1	
	TS0CTL3	1	TS0RIA	Don't care	Selects the reload timing of the compare register.
		0	TS0RMC	Don't care	Selects the transfer timing of the compare register.
	TS0CTL4	8	TS0PRE	Don't care	Enables or disables peak reload timing.
		7	TS0VRE	Don't care	Enables or disables valley reload timing.
		6	TS0PIE	Don't care	Enables or disables generation of the peak interrupt.
		5	TS0VIE	Don't care	Enables or disables generation of the valley interrupt.
		4 to 0	TS0RCC4, TS0RCC3, TS0RCC2, TS0RCC1, TS0RCC0	Don't care	Sets the thinning out rate of reload timing and interrupt.
	TS0IOC0	6	TS0TOE6	Don't care	Enables or disables rewrite of the TS0OL6 and TS0TO6 bits in TS0IOC2.
		5	TS0TOE5	Don't care	Enables or disables rewrite of the TS0OL5 and TS0TO5 bits in TS0IOC2.
		4	TS0TOE4	Don't care	Enables or disables rewrite of the TS0OL4 and TS0TO4 bits in TS0IOC2.
		3	TS0TOE3	Don't care	Enables or disables rewrite of the TS0OL3 and TS0TO3 bits in TS0IOC2.
		2	TS0TOE2	Don't care	Enables or disables rewrite of the TS0OL2 and TS0TO2 bits in TS0IOC2.
		1	TS0TOE1	Don't care	Enables or disables rewrite of the TS0OL1 and TS0TO1 bits in TS0IOC2.
	TS0IOC1	4	TS0PTS	1	Enables toggle signal output on edge detection of TSG20PTS10 to TSG20PTS12.
	TS0IOC2	14	TS0OL6	Don't care	Selects an active level of the TSG20O6 output.
		13	TS0OL5	Don't care	Selects an active level of the TSG20O5 output.
		12	TS0OL4	Don't care	Selects an active level of the TSG20O4 output.
		11	TS0OL3	Don't care	Selects an active level of the TSG20O3 output.
		10	TS0OL2	Don't care	Selects an active level of the TSG20O2 output.
	TS0OPT0	9	TS0OL1	Don't care	Selects an active level of the TSG20O1 output.
		6	TS0SOC	Don't care	Selects the control of the timer output with software.
		5	TS0STE	Don't care	Enables or disables the control with the pattern output trigger.
		4	TS0POT	Don't care	Selects the pattern output trigger. Selects either the output pattern switching by the external pattern input pin (TSG20PTS10 to TSG20PTS12) or output switching by the TS0OPC11 and TS0OPC10 rising edge as the pattern output trigger.
		3	TS0PSS	Don't care	Selects the pattern output order switching method. The pattern output order is switched with TS0PSC.
	TS0OPT1	2	TS0IDC	Don't care	Selects the direction of the motor rotation.
		1	TS0PSC	Don't care	Selects the order of the timer output pattern during semi-automatic cruise control.
	TS0OPT1	2 to 0	TS0SPC2 to TS0SPC0	Don't care	Sets the timer output pattern in software output function mode.
	TS0CMP0	—	—	Don't care	Compare register Sets the PWM period.
	TS0CMP1W	—	—	Don't care	Compare register Sets a compare value.
	TS0CMP5W	—	—	Don't care	Compare register Sets a compare value.
	TS0CMP9W	—	—	Don't care	Compare register Sets a compare value.
	TS0PAT0W	—	—	Don't care	Pattern register Sets the output pattern.
TS0PAT1W	—	—	Don't care	Pattern register Sets the output pattern.	
TS0DTC0W	—	—	Don't care	Dead time set register Sets the dead time value.	
TS0DTC1W	—	—	Don't care	Dead time set register Sets the dead time value.	

Table 24-48 PIC Setting

Function	Register	Bit Position	Bit Name	Set Value	Note
PIC	PIC0REG30	1	PIC0REG3001	See the block diagram	Outputs the TS0PUD signal of TSG20 and selects the ENCA0E1 input of ENCA0 timer.
		0	PIC0REG3000	See the block diagram	Selects the TS0PEC signal of TSG20 and selects the ENCA0E0 input of ENCA0 timer.
	PIC0REG50	0	PIC0REG500	See the block diagram	Selects TSG20PTSI0 to TSG20PTSI2 pin input.

24.4.9 CAN Time Stamp Function

24.4.9.1 Functional Overview

The time stamp function can be set for message reception by combining the CAN controller and CH8 or CH9 of TAUB0.

CH8 or CH9 of TAUB0 captures a timer value according to the TSOUT signal that is output from the CAN controller on reception of a data frame. The CPU reads the captured value and obtains the time when the capture event occurred, in other words, the time stamp of the message received via the CAN bus.

24.4.9.2 Configuration

Configuration/ Timer Function	CAN	TAUB
Configuration 1	CAN0	TAUB0 CH8
Configuration 2	CAN1	TAUB0 CH9

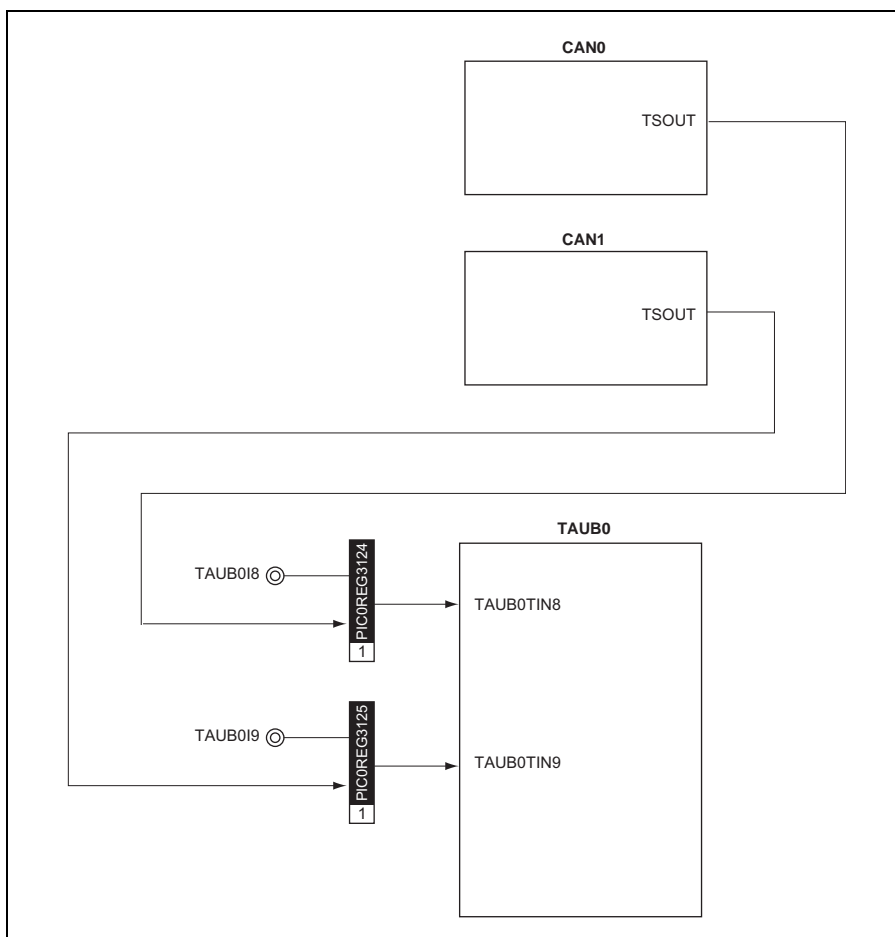

Figure 24-46 Block Diagram of CAN Time Stamp Function

24.4.9.3 Registers

(1) Timer I/O Control Register 31 (PIC0REG31)

PIC0REG31 is a 32-bit register that selects timer input signals.

Access This register can be read/written in 32-bit units.

Address FF81 C0EC_H

Initial value 0000 0000_H

This register is initialized by any reset.

31	30	29	28	27	26	25	24
0	0	0	0	0	0	PIC0REG 3125	PIC0REG 3124
R	R	R	R	R	R	R/W	R/W
23	22	21	20	19	18	17	16
0	0	0	0	0	0	0	0
R	R	R	R	R	R	R	R
15	14	13	12	11	10	9	8
0	0	0	0	0	0	0	0
R	R	R	R	R	R	R	R
7	6	5	4	3	2	1	0
0	0	0	0	0	0	0	0
R	R	R	R	R	R	R	R

Table 24-49 PIC0REG31 Contents

Bit Position	Bit Name	Function
25	PIC0REG3125	Selects the input signal for TAUB0CH9. 0: TAUB0TIN9 input 1: The trigger signal (TSOUT signal) for time stamping by CAN1
24	PIC0REG3124	Selects the input signal for TAUB0CH8. 0: TAUB0TIN8 input 1: The trigger signal (TSOUT signal) for time stamping by CAN0

- Caution 1. The bit might be defined to 0 by other timer connection functions. In that case, apply the bit definition of the corresponding timer connection function.
- Caution 2. Set the CAN0/CAN1 time stamp trigger signal (TSOUT signal) while the TSOUT signal toggle operation is disabled or before CAN operation is started. TSOUT signal toggle operation is disabled by setting FCNnCMTSCTL.FCNnCMTSTSGE to 0.
- Caution 3. CAN time stamping and baud rate detection for slave operation in LIN communications cannot be used simultaneously. When CAN time stamping is to run, do not input the signal for the UARTH function as the timer input signal for channels 8 and 9 of TAUB0.

24.4.10 TSG20 and TAUB0 Dead-Time Reduction Function

24.4.10.1 Functional Overview

With the TSG20 and TAUB0 in combination, setting the duty cycle for the TSG20 to 0% linearly reduces the dead time by almost 100%.

This function is realized by combining the output signals from TSG20 and from channels 4, 5, and 6 of TAUB0. The compare 0 interrupt signal and the compare 2, 6, and 10 interrupt signals from the TSG20 are selected as the input trigger signals for channels 4, 5, and 6 of TAUB0, and adjustment of the timing of the output signals from TSG20 and TAUB0 is selectable.

Note The unit number of the individual macro units is represented by the suffix n (n = 0, 1).

24.4.10.2 Configuration

The configuration of this function is described below.

Table 24-50 Configuration of Timer

Configuration/ Timer Function	TSG2	TAUB
Timer configuration 1	TSG20	TAUB0 Ch4/5/6

Configuration and Pin Functions of Each Timer	TSG2 Output Signal	TAUB	
		Input Signal	Output Signal
Timer configuration 1	TSG20TO1 TSG20TO2 TSG20TO3 TSG20TO4 TSG20TO5 TSG20TO6	-	TAUB0TOUT4 TAUB0TOUT5 TAUB0TOUT6
	TSG20INT0 TSG20INT2 TSG20INT6 TSG20INT10	TAUB0TIN4 TAUB0TIN5 TAUB0TIN6	

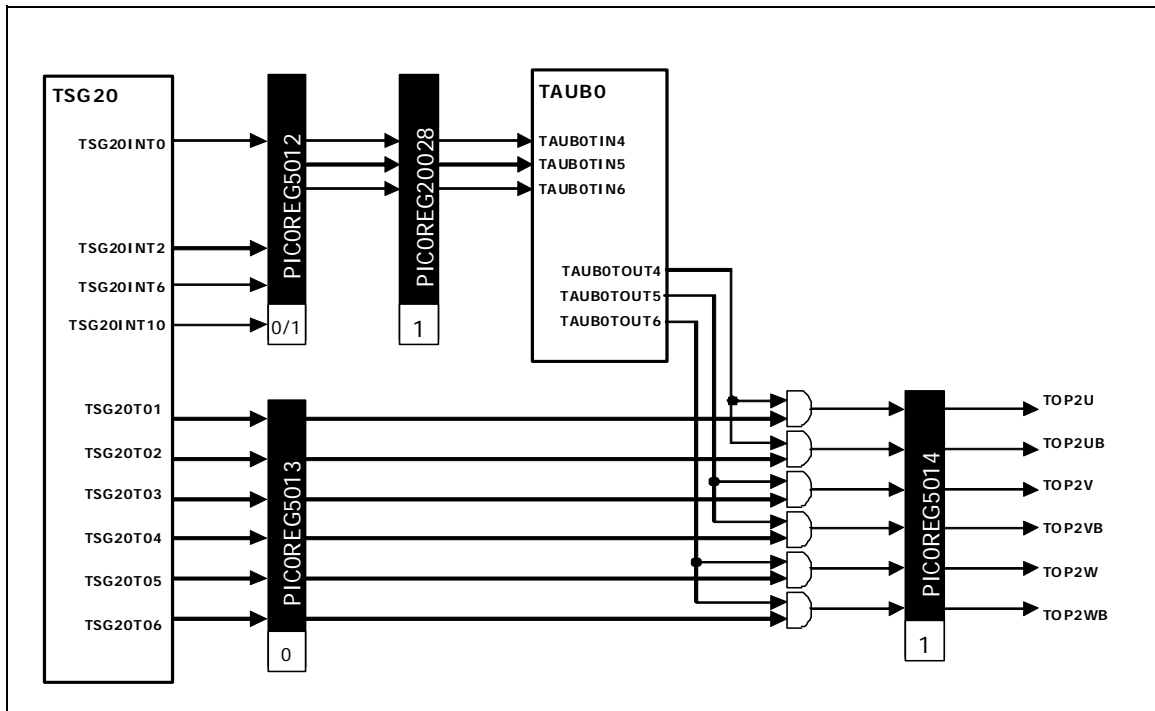

Figure 24-47 Block Diagram of TSG20 and TAUB0 Dead-Time Reduction Function

24.4.10.3 Registers

(1) Timer I/O Control Register 50 (PIC0REG50)

PIC0REG50 is a 16-bit register that inputs the signal output from TSG20 to TAUB0.

Access This register can be read/written in 16-bit units.

Address FF83 C0F8_H

Initial value 0000_H

This register is initialized by any reset.

15	14	13	12	11	10	9	8
0	PIC0REG 5014	0	PIC0REG 5012	0	0	0	0
R	R/W	R	R/W	R	R	R	R
7	6	5	4	3	2	1	0
0	0	0	0	0	0	0	0
R	R	R	R	R	R	R	R

Table 24-51 PIC0REG50 Contents

Bit Position	Bit Name	Function
14	PIC0REG5014	Select the TOP2U/UB, TOP2V/VB, and TOP2W/WB output signals. Be sure to set the PIC0REG5014 bit to 1 when using the TSG20 and TAUB0 dead-time reduction function.
12	PIC0REG5012	Select the TAUB0TIN4, TAUB0TIN5, and TAUB0TIN6 input signals. 0: TSG20INT0 input 1: TSG20INT2, TSG20INT4, and TSG20INT6 input

Caution The bit might be defined to 0 by other timer connection functions. In that case, apply the bit definition of the corresponding PIC connection function.

(2) Timer I/O Control Register 200 (PIC0REG200)

PIC0REG200 is a 32-bit register that selects the signal for input to TAUB0.

Access This register can be read/written in 32-bit units.

Address FF81 C0C0_H

Initial value 0000 0000_H

This register is initialized by any reset.

31	30	29	28	27	26	25	24
0	0	0	0	0	0	0	0
R	R	R	R	R	R	R	R
23	22	21	20	19	18	17	16
0	0	0	0	0	0	0	0
R	R	R	R	R	R	R	R
15	14	13	12	11	10	9	8
0	0	0	0	0	0	0	0
R	R	R	R	R	R	R	R
7	6	5	4	3	2	1	0
0	0	0	0	0	0	0	0
R	R	R	R	R	R	R	R

-
- Caution 1. Be sure to set the PIC0REG2028 bit to 1 when using the TSG20 and TAUB0 dead-time reduction function.
 - Caution 2. The bit might be defined to 0 by other timer connection functions. In that case, apply the bit definition of the corresponding PIC connection function.
-

24.4.10.4 Example of Operation

(1) TSG20 Compare 0 Interrupt and TAUB0 Operation

To realize dead-time reduction from the combination of TSG20 and TAUB0, select the TSG20 output compare 0 interrupt signal (TSG20INT0) as the timer start trigger signal for input to the TAUB0 channels (TAUB0TIN4/5/6).

For the connection of the combination, see Table 24-50.

The following is an overview of the connection and example of operation.

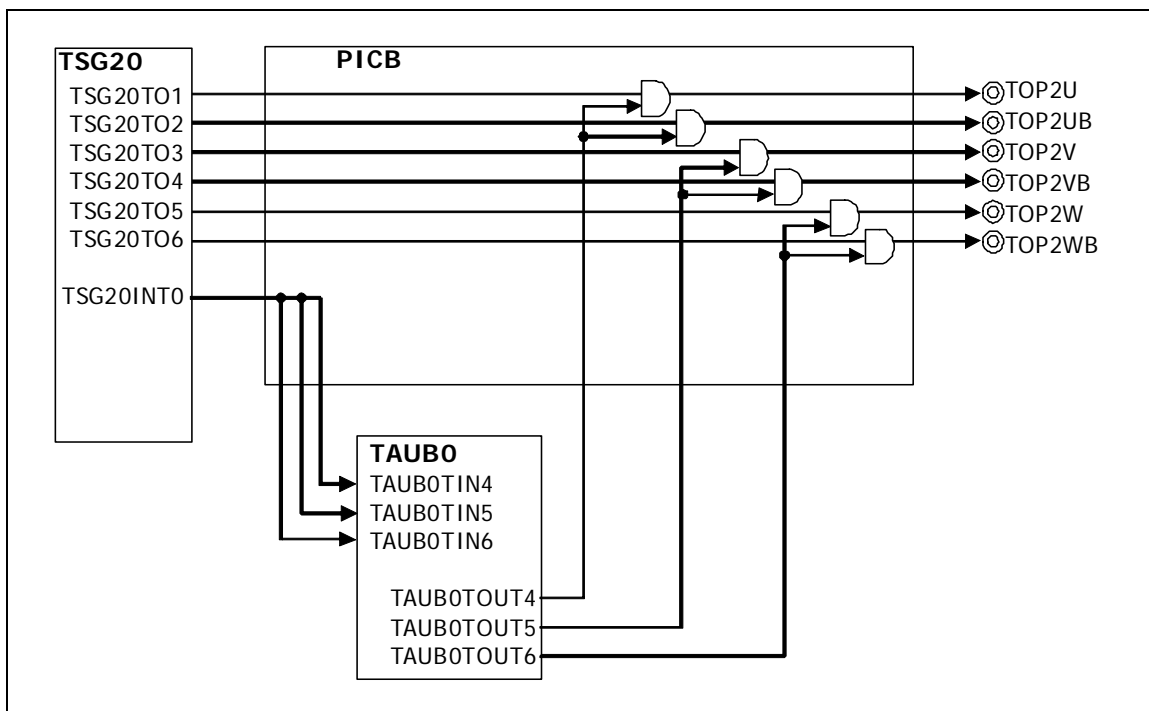

Figure 24-48 Overview of TSG20 Compare 0 Interrupt and TAUB0 Connection

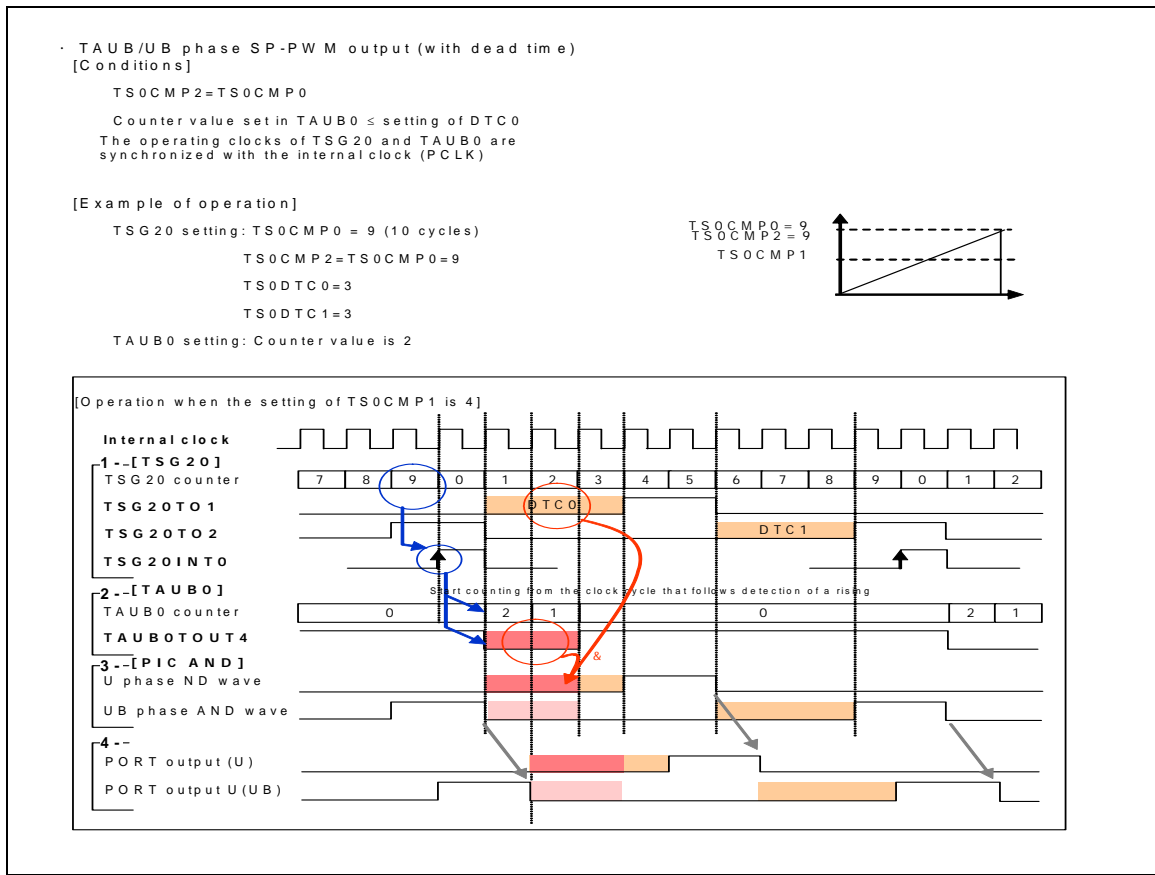

Figure 24-49 Example of Operation of the TSG20 Compare 0 Interrupt and TAUB0

- Note 1. When duty cycles of 0% [TS0CMP1 = 0] and 100% [TS0CMP1 = 10] are set, as the TSG20 output is driven high or low, the TAUB0TOUT4 waveform shown above is output as the PORT (U/UB) output waveform.
- Note 2. When the compare 0 interrupt (TSG20INT0) is to be used, TS0CMP2 = TS0CMP0 should be set.
- Note 3. The following describes operations 1 to 4 in the figure above.
- 1- TSG20 operates in SP-PWM mode (with dead time). It periodically generates compare 0 interrupts.
 - 2- The rising edge of the compare 0 interrupt acts as the trigger to start counting by TAUB0.
 - 3- The logical AND of the signals output by TSG20 and TAUB20 is generated.
 - 4- The signal generated in step 3 is regenerated by PCLK and output from a port.

(2) TSG20 Compare 2/6/10 Interrupt and TAUB0 Operation

To realize dead-time reduction from the combination of TSG20 and TAUB0, select the TSG20 output compare 2/6/10 interrupt signal (TSG20INT2/6/10) as the timer start trigger signal for input to the TAUB0 channels (TAUB0TIN4/5/6).

For the connection of the combination, see Table 24-50.

The following is an overview of the connection and example of operation.

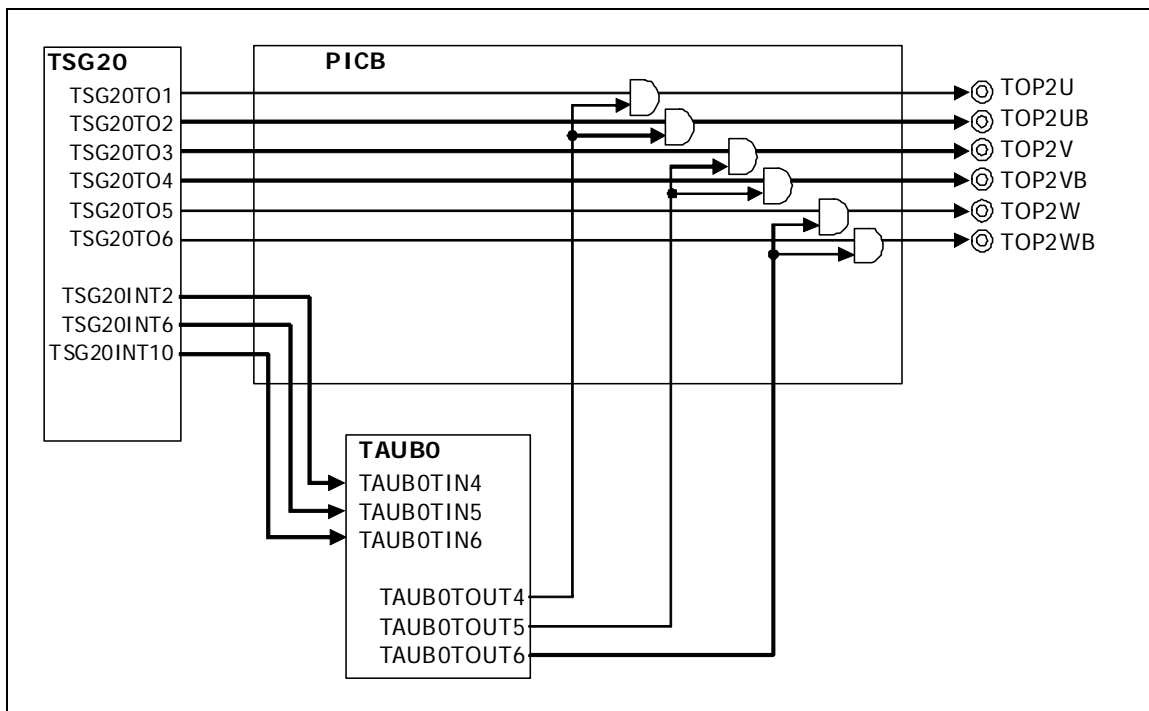

Figure 24-50 Overview of TSG20 Compare 0 Interrupt and TAUB0 Connection

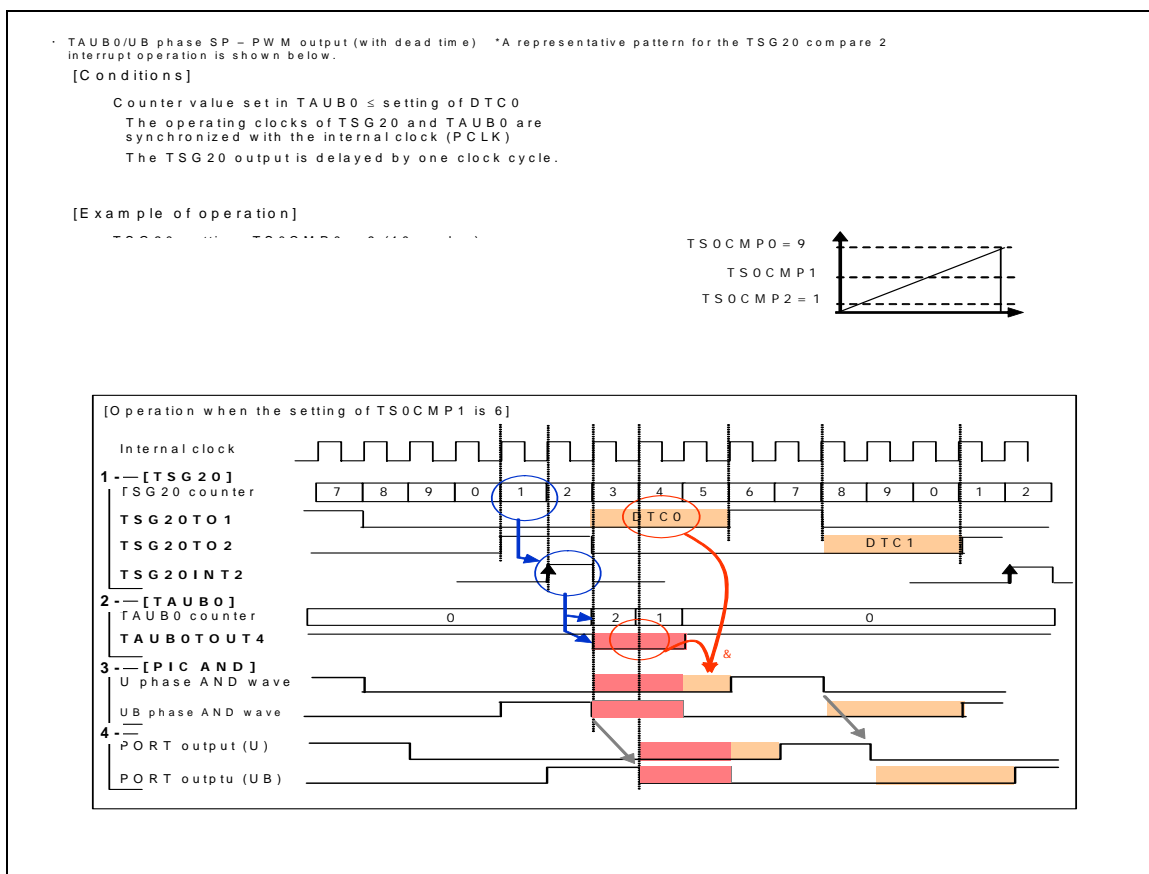
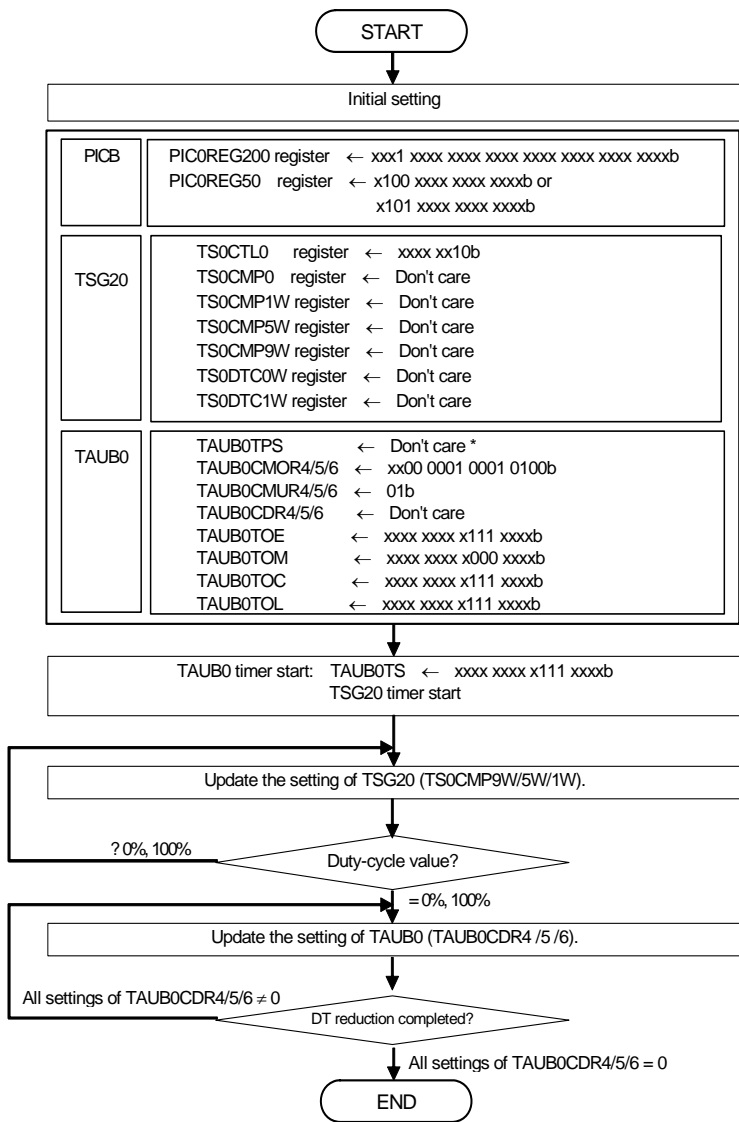

Figure 24-51 Example of Operation of the TSG20 Compare 0 Interrupt and TAUB0

- Note 1. When duty cycles of 0% [TS0CMP1 = 0] and 100% [TS0CMP1 = 10] are set, as the TSG20 output is driven high or low, the TAUB0TOUT4 waveform shown above is output as the PORT (U/UB) output waveform.
- Note 2. The following describes operations 1 to 4 in the figure above.
- 1- TSG20 operates in SP-PWM mode (with dead time). It periodically generates compare 2 interrupts.
 - 2- The rising edge of the compare 2 interrupt acts as the trigger to start counting by TAUB0.
 - 3- The logical AND of the signals output by TSG20 and TAUB is generated.
 - 4- The signal generated in step 3 is regenerated by PCLK and output from a port.

24.4.10.5 Operation Flow



* Make settings so that PCLK is used as the operating clock and is not frequency-divided.

Figure 24-52 Initial Setting, Operation Start Flow

24.4.10.6 Function Setting

Settings are made in the PICB register so that the compare 0 interrupt from TSG20 acts as the trigger to start counting by TAUB0 and for connecting the output signals from TSG20 (TSG20nTO1 to 6) and from TAUB0 (TAUB0TOUT4 to 6) through an AND gate are listed below. Refer to the settings for the connections to be used. Leave bits of registers that are not listed at their initial values.

Table 24-52 TSG20 Setting

Function	Register	Bit Position	Bit Name	Set Value	Note
TSG20	TS0CTL0	1-0	TS0MD1, TS0MD0	1,1	Operating mode selection (SP-PWM)
	TS0TRG0	0	TS0TS	0	Trigger to start a timer
	TS0CMP0	-	-	Don't care	Comparison register Set the PWM cycle
	TS0CMP1W	-	-	Don't care	Comparison register Set the value for comparison. • When the compare 0 interrupt is to be used, set TS0CMP2 = TS0CMP0.
	TS0CMP1W	-	-	Don't care	Comparison register Set the value for comparison. • When the compare 0 interrupt is to be used, set TS0CMP6 = TS0CMP0.
	TS0CMP1W	-	-	Don't care	Comparison register Set the value for comparison. • When the compare 0 interrupt is to be used, set TS0CMP10 = TS0CMP0.
	TS0CMP1,5,9	-	-	Don't care	Comparison register Set the value for comparison.
	TS0CMP2,6, 10	-	-	Don't care	Comparison register Set the value for comparison. • When the compare 0 interrupt is to be used, set the same value as in TS0CMP0.
	TS0DTC0W	-	-	Don't care	Dead-time setting register Set the dead-time value.
	TS0DTC1W	-	-	Don't care	Dead-time setting register Set the dead-time value.

Caution Make settings so that PCLK is used as the operating clock and is not frequency-divided.

Table 24-53 TAUB0 Setting

Function	Register	Bit Position	Bit Name	Set Value	Note
TAUB	TAUB0TPS	15-12	PRS33-PRS30	Don't care	Set any one to 0000b so that PCLK is output without frequency division.
		11-8	PRS23-PRS20		
		7-4	PRS13-PRS10		
		3-0	PRS03-PRS00		
	TAUB0CDR6, TAUB0CDR5, TAUB0CDR4			Don't care	The operating mode of the CHm capture/ comparison register is automatically switched between capture and comparison.
	TAUB0CMORm	15, 14	CKS1, CKS0	Don't care	Select the operating clock for the channels (so that PCLK is the operating clock).
		13, 12	CCS1, CCS0	0, 0	Select the prescaler output as the clock to drive counting.
		11	MAS	0	Not used
		10-8	STS2-STS0	0, 0, 1	Select the valid edge of the TAUB0TI4, 5, and 6 input signals that is to act as an external start trigger.
		7, 6	COS1, COS0	0, 0	Not used
		4-0	MD4-MD0	1, 0, 1, 0, 0	Select the pulse one-count mode Disable the start trigger during operation.
	TAUB0CMUR6, TAUB0CMUR5, TAUB0CMUR4	1, 0	TIS1, TIS0	0,1	Select the detection of rising edges.
	TAUB0TOE	6-4	TAUB0TOE06- TAUB0TOE04	1, 1, 1	Channels 4, 5, and 6 Enable the timer single-output function
	TAUB0TOM	6-4	TAUB0TOM06- TAUB0TOM04	0, 0, 0	Channels 4, 5, and 6 Select the channel's stand-alone operation output mode.
	TAUB0TOC	6-4	TAUB0TOC06- TAUB0TOC04	1, 1, 1	Channel 4, 5, and 6 Select output in the set/reset mode.
	TAUB0TOL	6-4	TAUB0TOL06- TAUB0TOL04	1, 1, 1	Channel 4, 5, and 6 Select inverse logic (active-low) for the output.
TAUB0TS	6-4	TAUB0TS06- TAUB0TS04	1, 1, 1	Channel 4, 5, and 6 Enable operation of the counters	

Caution Make settings so that PCLK is used as the operating clock and is not frequency-divided.

Table 24-54 PICB Settings for the TSG20 Compare 0 Interrupt and TAUB0 Operation

Function	Register	Bit Position	Bit Name	Set Value	Note
PIC	PIC0REG50	14	PIC0REG5014	1	Select the logical AND of the TAUB0TOUT4, 5, and 6 signals for resetting the flip-flop.
		12	PIC0REG5012	0	Select the TSG20 compare 0 interrupt signal.
	PIC0REG200	28	PIC0REG20028	1	Select the TSG20 output comparison interrupt signal as the signal for input to the TAUB0TIN4, 5, and 6 input pins (the signal selected by bit 12 in PIC0REG50).

Table 24-55 PICB Settings for the TSG20 Compare 2, 6, and 10 Interrupts and TAUB0 Operation

Function	Register	Bit Position	Bit Name	Set Value	Note
PIC	PIC0REG50	14	PIC0REG5014	1	Select the logical AND of the TAUB0TOUT4, 5, and 6 signals for resetting the flip-flop.
		12	PIC0REG5012	0	Select the TSG20 compare 2/6/10 interrupt signal.
	PIC0REG200	28	PIC0REG20028	1	Select the TSG20 output comparison interrupt signal as the signal for input to the TAUB0TIN4, 5, and 6 input pins (the signal selected by bit 12 in PIC0REG50).

24.4.11 TAUB Input Selection

24.4.11.1 Functional Overview

The input signal on the TIN pin at the point of input to TAUB and multiplexed on a specific pin can be used at the same time.

Note The unit number of the individual macro units is represented by the suffix n (n = 0, 1).

24.4.11.2 Configuration

The configuration of this function is described below.

Table 24-56 Configuration of Timer

Configuration/Timer Function	TAUB
Timer configuration	TAUB0

Configuration and Pin Functions of Each Timer	TAUB
	Input pin
TAUB0 external input	TAUB0I6/TAUB0I7 TAUB0I8/TAUB0I9 TAUB0I10/TAUB0I11

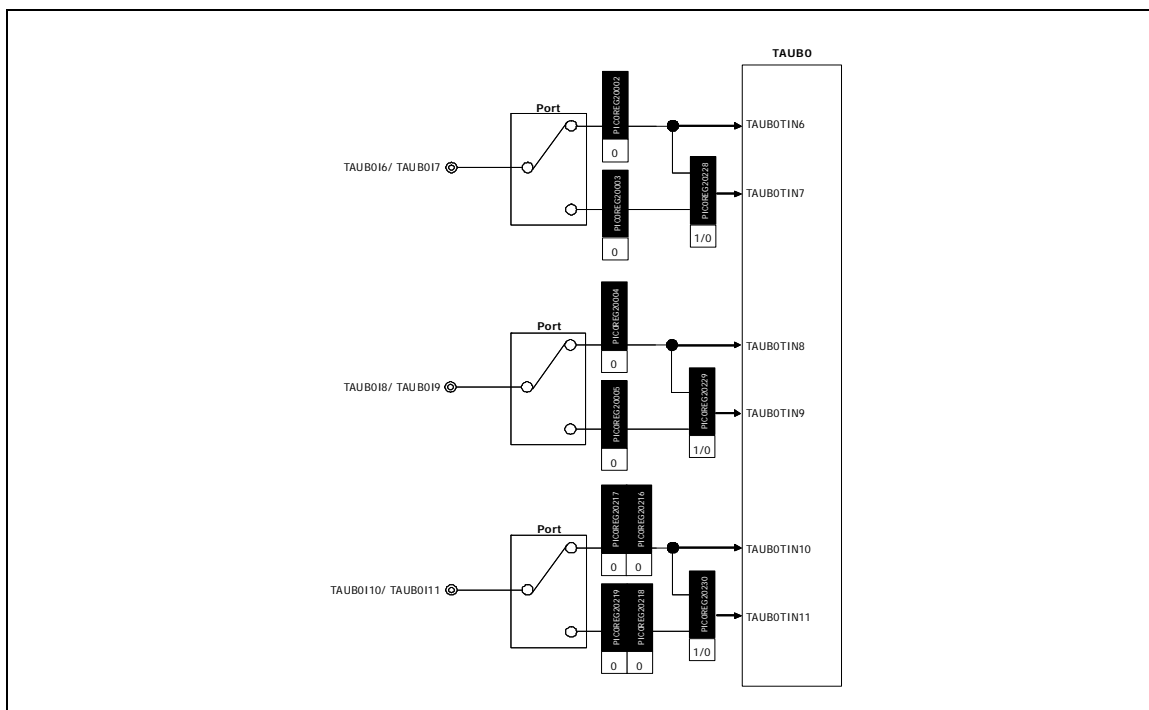

Figure 24-53 Block Diagram of TAUB Input Selection

24.4.11.3 Registers

(1) Timer I/O Control Register 200 (PIC0REG200)

PIC0REG200 is a 32-bit register that selects the signal for input to the timer.

Access This register can be read/written in 32-bit units.

Address FF81 C0C0_H

Initial value 0000 0000_H

This register is initialized by any reset.

31	30	29	28	27	26	25	24
0	0	0	0	0	0	0	0
R	R	R	R	R	R	R	R
23	22	21	20	19	18	17	16
0	0	0	0	0	0	0	0
R	R	R	R	R	R	R	R
15	14	13	12	11	10	9	8
0	0	0	0	0	0	0	0
R	R	R	R	R	R	R	R
7	6	5	4	3	2	1	0
0	0	PIC0REG20005	PIC0REG20004	PIC0REG20003	PIC0REG20002	0	0
R	R	R/W	R/W	R/W	R/W	R	R

Table 24-57 PIC0REG200 Contents

Bit Position	Bit Name	Function
5	PIC0REG20005	Select the TAUB0 CH09 input signal. 0: TAUB0I9 input 1: Setting is prohibited.
4	PIC0REG20004	Select the TAUB0 CH08 input signal. 0: TAUB0I8 input 1: Setting is prohibited.
3	PIC0REG20003	Select the TAUB0 CH07 input signal. 0: TAUB0I7 input 1: Setting is prohibited.
2	PIC0REG20002	Select the TAUB0 CH06 input signal. 0: TAUB0I6 input 1: Setting is prohibited.

Caution The bit might be defined to 0 by other timer connection functions. In that case, apply the bit definition of the corresponding PIC connection function.

(2) Timer I/O Control Register 202 (PIC0REG202)

PIC0REG202 is a 32-bit register that selects the signal for input to the timer.

Access This register can be read/written in 32-bit units.

Address FF81 C0C8_H

Initial value 0000 0000_H

This register is initialized by any reset.

31	30	29	28	27	26	25	24
0	PIC0REG G20230	PIC0REG G20229	PIC0REG G20228	0	0	0	0
R	R/W	R/W	R/W	R	R	R	R
23	22	21	20	19	18	17	16
0	0	0	0	PIC0REG G20219	PIC0REG G20218	PIC0REG G20217	PIC0REG G20216
R	R	R	R	R/W	R/W	R/W	R/W
15	14	13	12	11	10	9	8
0	0	0	0	0	0	0	0
R	R	R	R	R	R	R	R
7	6	5	4	3	2	1	0
0	0	0	0	0	0	0	0
R	R	R	R	R	R	R	R

Table 24-58 PIC0REG202 Contents (1/2)

Bit Position	Bit Name	Function						
30	PIC0REG20230	Select the TAUB0 CH11 input signal. <table border="1"> <thead> <tr> <th>PIC0REG20230</th> <th>Input Signal</th> </tr> </thead> <tbody> <tr> <td>0</td> <td>Select the signal (TAUB0I11) set by bits 18 and 19 in PIC0REG202.</td> </tr> <tr> <td>1</td> <td>Select the signal (TAUB0I10) set by bits 16 and 17 in PIC0REG202.</td> </tr> </tbody> </table>	PIC0REG20230	Input Signal	0	Select the signal (TAUB0I11) set by bits 18 and 19 in PIC0REG202.	1	Select the signal (TAUB0I10) set by bits 16 and 17 in PIC0REG202.
PIC0REG20230	Input Signal							
0	Select the signal (TAUB0I11) set by bits 18 and 19 in PIC0REG202.							
1	Select the signal (TAUB0I10) set by bits 16 and 17 in PIC0REG202.							
29	PIC0REG20229	Select the TAUB0 CH9 input signal. <table border="1"> <thead> <tr> <th>PIC0REG20229</th> <th>Input Signal</th> </tr> </thead> <tbody> <tr> <td>0</td> <td>Select the signal (TAUB0I9) set by bit 5 in PIC0REG200.</td> </tr> <tr> <td>1</td> <td>Select the signal (TAUB0I8) set by bit 4 in PIC0REG200.</td> </tr> </tbody> </table>	PIC0REG20229	Input Signal	0	Select the signal (TAUB0I9) set by bit 5 in PIC0REG200.	1	Select the signal (TAUB0I8) set by bit 4 in PIC0REG200.
PIC0REG20229	Input Signal							
0	Select the signal (TAUB0I9) set by bit 5 in PIC0REG200.							
1	Select the signal (TAUB0I8) set by bit 4 in PIC0REG200.							

Table 24-58 PIC0REG202 Contents (2/2)

Bit Position	Bit Name	Function									
28	PIC0REG20228	Select the TAUB0 CH7 input signal. <table border="1"> <thead> <tr> <th>PIC0REG20228</th> <th>Input Signal</th> </tr> </thead> <tbody> <tr> <td>0</td> <td>Select the signal (TAUB0I7) set by bit 3 in PIC0REG200.</td> </tr> <tr> <td>1</td> <td>Select the signal (TAUB0I6) set by bit 2 in PIC0REG200.</td> </tr> </tbody> </table>	PIC0REG20228	Input Signal	0	Select the signal (TAUB0I7) set by bit 3 in PIC0REG200.	1	Select the signal (TAUB0I6) set by bit 2 in PIC0REG200.			
PIC0REG20228	Input Signal										
0	Select the signal (TAUB0I7) set by bit 3 in PIC0REG200.										
1	Select the signal (TAUB0I6) set by bit 2 in PIC0REG200.										
19, 18	PIC0REG20219, PIC0REG20218	Select the TAUB0 CH11 input signal. <table border="1"> <thead> <tr> <th>PIC0REG20019</th> <th>PIC0REG20018</th> <th>Input Signal</th> </tr> </thead> <tbody> <tr> <td>0</td> <td>0</td> <td>TAUB0I11</td> </tr> <tr> <td colspan="2">Other than the above</td> <td>Setting is prohibited.</td> </tr> </tbody> </table>	PIC0REG20019	PIC0REG20018	Input Signal	0	0	TAUB0I11	Other than the above		Setting is prohibited.
PIC0REG20019	PIC0REG20018	Input Signal									
0	0	TAUB0I11									
Other than the above		Setting is prohibited.									
17, 16	PIC0REG20217, PIC0REG20216	Select the TAUB0 CH10 input signal. <table border="1"> <thead> <tr> <th>PIC0REG20017</th> <th>PIC0REG20016</th> <th>Input Signal</th> </tr> </thead> <tbody> <tr> <td>0</td> <td>0</td> <td>TAUB0I10</td> </tr> <tr> <td colspan="2">Other than the above</td> <td>Setting is prohibited.</td> </tr> </tbody> </table>	PIC0REG20017	PIC0REG20016	Input Signal	0	0	TAUB0I10	Other than the above		Setting is prohibited.
PIC0REG20017	PIC0REG20016	Input Signal									
0	0	TAUB0I10									
Other than the above		Setting is prohibited.									

Caution The bit might be defined to 0 by other timer connection functions. In that case, apply the bit definition of the corresponding PIC connection function.

24.4.11.4 Example of Operation

Through this function, the input signal multiplexed on a specific pin (the input pin for the output section of TAUB0) is connectable as the TIN signal for TAUB at the same time. The connectable combinations are as listed below.

Table 24-59 Example of Connection of the External Input Pin for TAUB and TAUB0TINm

Target Pin	Pin Function	Note
TAUB0I6/TAUB0I7	TAUB0I6	Connect the TAUB0I6 signal to TAUB0I6TAUB0TIN6.
		Set PIC0REG20228 to select the TAUB0TIN7 connection. 1: TAUB0I6 connected 0: No connection
	TAUB0I7	Disable the signal connection to TAUB0TIN6.
		Set PIC0REG20228 to select the TAUB0TIN7 connection. 1: TAUB0I7 connected 0: No connection
TAUB0I8/TAUB0I9	TAUB0I8	Connect the TAUB0I8 signal to TAUB0I8TAUB0TIN8.
		Set PIC0REG20229 to select the TAUB0TIN9 connection. 1: TAUB0I8 connected 0: No connection
	TAUB0I9	Disable the signal connection to TAUB0TIN8.
		Set PIC0REG20229 to select the TAUB0TIN9 connection. 1: TAUB0I9 connected 0: No connection
TAUB0I10/TAUB0I11	TAUB0I10	Connect the TAUB0I10 signal to TAUB0TIN10.
		Set PIC0REG20230 to select the TAUB0TIN11 connection. 1: TAUB0I10 connected 0: No connection
	TAUB0I11	Disable the signal connection to TAUB0TIN10.
		Set PIC0REG20230 to select the TAUB0TIN11 connection. 1: TAUB0I11 connected 0: No connection

Section 25 On-chip Debugging Unit (OCD)

The on-chip debugging function is described in this section.

The on-chip debugging emulator allows the debugging of programs with the microcontroller mounted on the target system.

The debugging function incorporated in this microcontroller conforms to IEEE-ISTO 5001TM-2003 Class 1, a Nexus debugging interface standard.

Caution While the microcontroller supports the debugging functions described in this section, whether they are usable or not depends on the debugger. For details on debugging, see the user's manual for the debugger.

25.1 Functional Overview

An overview of the on-chip debugging function is given below.

(1) Debugging Interface

This interface is used to communicate with the host via the on-chip debugging emulator by using the following interface.

- Nexus debugging interface: DCUTRST, DCUTCK, DCUTMS, DCUTDI, DCUTDO, and DCUTRDY signals
- LPD interface (single-pin debugging interface): LPDIO signal

(2) Debugging Monitor

The basic debugging functions below can be used by running a monitor program in a memory space for debugging while the user-created program is suspended.

- Downloading of user-created programs
- Reading and writing memory and registers
- Running user-created programs starting at any address

(3) Hardware Breaks

Up to four breakpoints can be specified for instructions and data. If a breakpoint is specified for an instruction, execution will be suspended at any address. If a breakpoint is specified for an address, execution will be suspended by access to data at any address.

Break conditions can be combined in sequences with up to two steps.

(4) Software Breaks

Software breaks are used to suspend (cause a break in) the execution of user-created programs stored in RAM at any address.

(5) Forced Breaks

A user-created program can be forcibly suspended.

(6) Forced Resetting

The microcontroller can be forcibly reset.

(7) Real-Time RAM Monitoring (RRM)

Memory can be read while the program is running. Since this read access is through debugging-dedicated DMA, it barely affects program execution.

(8) Dynamic Memory Modification (DMM)

Memory can be rewritten while the program is running. Since this rewrite access is through debugging-dedicated DMA, it barely affects program execution.

(9) Measuring Times

- Nexus debugging interface

Using a 32-bit counter, times taken to execute user-created programs can be measured based on a clock signal obtained by dividing the TCK signal frequency by two.

- LPD interface

Using a 32-bit counter, times can be measured based on a clock signal obtained by dividing the CPU clock frequency by eight.

(10) Masking

The following signal can be masked:

$\overline{\text{RESET}}$, internal resets

(11) Selecting if Peripheral I/O Modules Run or Stop during Breaks

Whether peripheral I/O modules run or stop is selectable.

- Peripheral I/O modules always stop operating during a break.
 - Watchdog timer (WDTA0)
- Selecting whether modules run or stop during a break
 - Timers (TSG2n, TAUBn, TAUJn, ENCA_n, OSTM_n)
 - Asynchronous serial interfaces (UARTH_n)
 - Three-line serial interfaces (CSIGN)
 - CAN controller (FCN_n)
 - A/D converter (ADCA_n)

(12) Hot Plug-in

The on-chip debugging emulator can be connected and debugging can start without resetting the CPU while it is running (hot plug-out is not supported).

(13) Security

To prevent unauthorized parties reading the contents of the flash memory, a 96-bit ID code can be written to the microcontroller. If the code the user inputs does not match the ID code written to the microcontroller when starting the debugger, the flash memory is not accessible. If the last bit (bit 95) is set to 0, the flash memory is not accessible even if the ID codes match.

For details of how to set the ID code, see the user's manual for the software tools you are using.

(14) Trigger Events

The trigger events detect an event with four-step sequential execution on the execution address, the access address, the access data, and the range (comparison of large and small sizes).

25.2 Connection with the On-Chip Debugging Emulator

(1) Nexus Debugging Interface

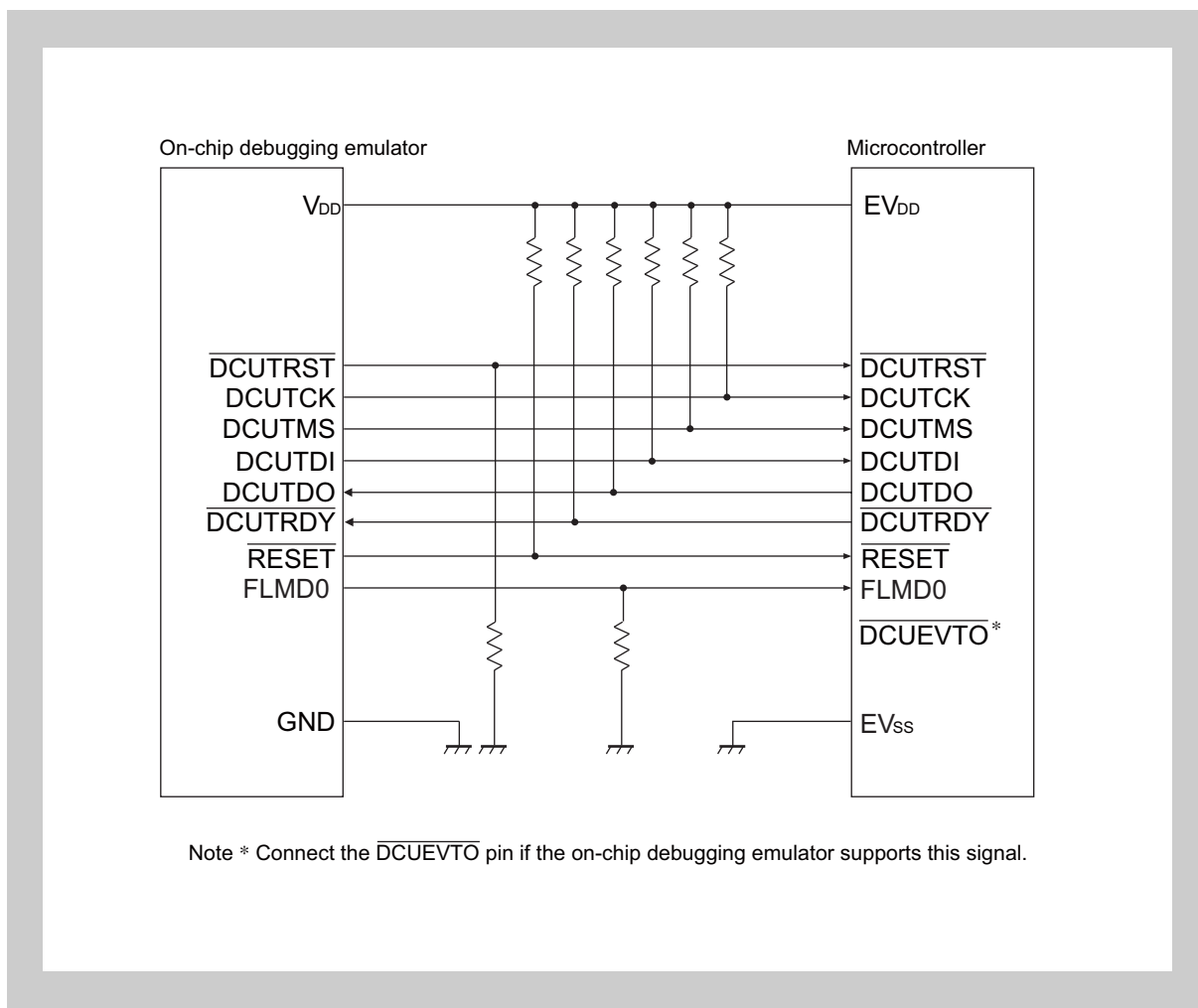
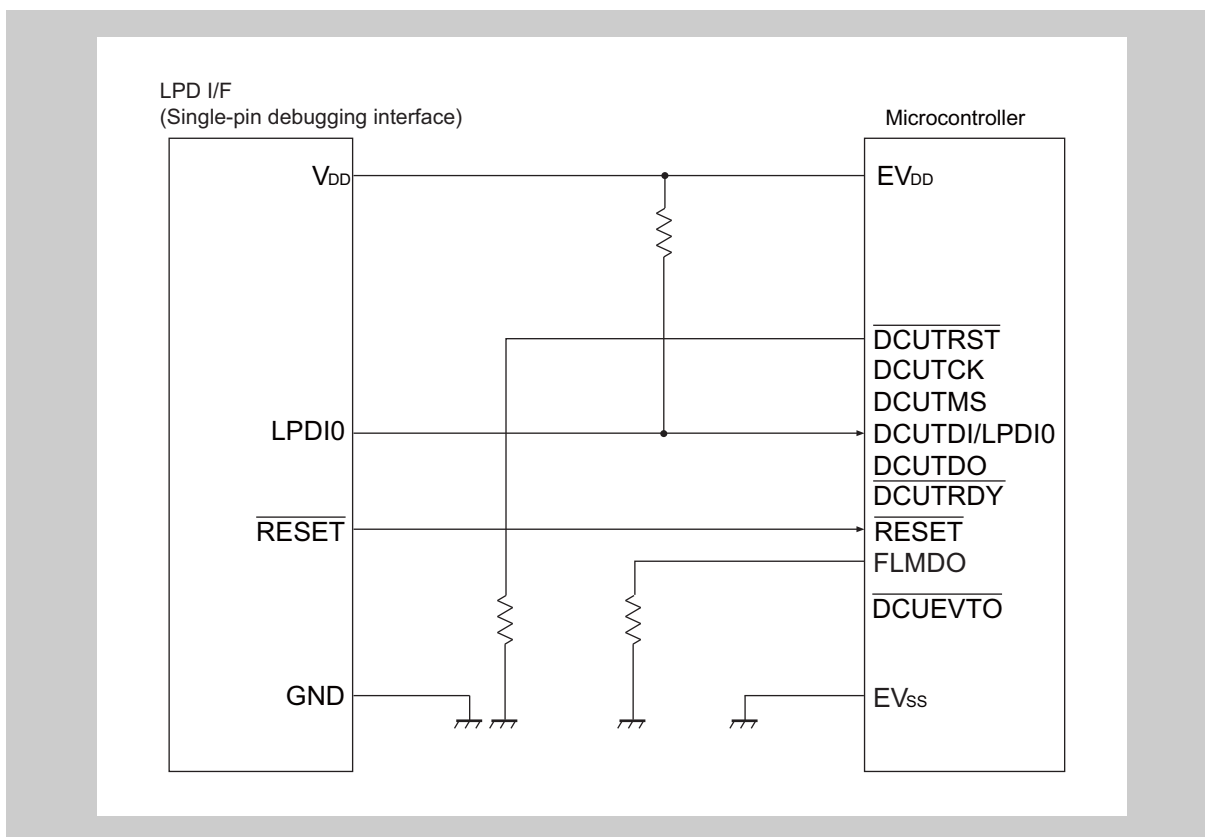

Figure 25-1 Pins Used for Connection with the On-Chip Debugging Emulator

Table 25-1 Pins Used for Connection with the on-Chip Debugging Emulator

Pin Name	Description
V _{DD}	Signal used to detect power supply to the target system and power supply for the buffers in the on-chip debugging emulator
DCUTRST	Signal for asynchronously resetting the debugging functions of the microcontroller
DCUTCK	Clock signal used in debugging
DCUTMS	Signal to select the mode of data transfer
DCUTDI	Input data signal for the microcontroller
DCUTDO	Output data signal from the microcontroller
DCUTRDY	Synchronization signal for data transfer
RESET	Reset signal for the microcontroller: this is connected so that the microcontroller is placed in the reset state from the supply of system power until the debugger starts.
FLMDO	Mode signal used in rewriting the contents of flash memory in the microcontroller

(2) LPD I/F (Single-pin debugging interface)



The pins used for Single-pin debugging are listed in Table 25-2, Pins Used for Connection with the on-Chip Debugging Emulator (LPD I/F). In Single-pin debugging, the $\overline{\text{DCUTRST}}$ pin must always be pulled down externally.

Table 25-2 Pins Used for Connection with the on-Chip Debugging Emulator (LPD I/F)

Pin Name	Function
LPDIO	Dedicated signal for the LPD interface

25.3 Notes on On-Chip Debugging

(1) Using Nexus Debugging Interface

1. Handling of devices used for debugging
Do not mount a device that was used in debugging on a mass-produced product, because the rewriting of flash memory during debugging will mean that the number of times flash memory is rewritable cannot be guaranteed.
2. After power is supplied to the microcomputer, place the high level on the $\overline{\text{RESET}}$ pin while the $\overline{\text{DCUTRST}}$ pin is low. If the internal Nexus function has not been initialized yet so that the signal on the $\overline{\text{RESET}}$ pin changes from the low to the high level while the signal on the $\overline{\text{DCUTRST}}$ pin is still high, release from the reset state will not proceed because internal signals are undefined, and the CPU will not operate.
3. After the chip is released from the $\overline{\text{RESET}}$ state and the transition of the level on the $\overline{\text{DCUTRDY}}$ pin from the high to the low level, wait until at least 10 cycles of the clock signal on the $\overline{\text{DCUTCK}}$ pin are input while the $\overline{\text{DCUTMS}}$ pin is at the high level and the $\overline{\text{DCUTRST}}$ pin is at the low level before setting the $\overline{\text{DCUTRST}}$ pin to the high level.
4. Once the $\overline{\text{DCUTRST}}$ pin is at the high level, keep it at the high level (i.e. do not change the level back from high to low once the $\overline{\text{DCUTRST}}$ pin is set to the high level). This product supports the Nexus debugging interface and single-pin debugging interface, but does not support changing the debugging interface during on-chip debugging. To change the debugging interface, set the $\overline{\text{RESET}}$ and $\overline{\text{DCUTRST}}$ pins to the low level, and then turn the power supply off and on.
5. Terminating operation in on-chip debugging mode under any of the following conditions causes operation to become undefined. After terminating operations in the on-chip debugging mode, set the $\overline{\text{RESET}}$ pin and the $\overline{\text{DCUTRST}}$ pin to the low level so that the start-up sequence for Nexus is executed.
 - Power supply off
 - Low level on the $\overline{\text{DCUTRST}}$ pin
 - The on-chip debugging ID code did not match (comparison always proceeds, i.e. is not only performed once)
 - High level on the $\overline{\text{FLMD0}}$ pin and low level on the $\overline{\text{RESET}}$ pin
6. Debugging is suspended if the low level is input on the $\overline{\text{RESET}}$ pin while the $\overline{\text{FLMD0}}$ pin is at the high level (used for self-programming, etc.) in the on-chip debugging mode. Re-apply the high level on the $\overline{\text{RESET}}$ pin while the $\overline{\text{FLMD0}}$ pin is at the low level.
7. If a reset ($\overline{\text{RESET}}$, $\overline{\text{WDTA0RES}}$, $\overline{\text{CLMA0RES}}$ to $\overline{\text{CLMA2RES}}$, $\overline{\text{LVIRES}}$, $\overline{\text{SGARES}}$, $\overline{\text{DBRES}}$) is generated after the high level is on the $\overline{\text{DCUTRST}}$ pin but before the on-chip debugging ID is verified, the tool may not communicate with the microcomputer. In such cases, apply the low level on the $\overline{\text{DCUTRST}}$ pin, and then turn the power supply off and on.
8. When the external reset signal goes to the active level during on-chip debugging, the $\overline{\text{ERROROUT}}$ pin is fixed to the low level (when the external reset signal becomes active in single-chip mode, the $\overline{\text{ERROROUT}}$ pin will also go to the low level).

9. When a reset is produced by $\overline{\text{RESET}}$, $\overline{\text{WDTA0RES}}$, $\overline{\text{CLMA0RES}}$ to $\overline{\text{CLMA2RES}}$, $\overline{\text{LVIRES}}$, $\overline{\text{SGARES}}$, or $\overline{\text{DBRES}}$ during on-chip debugging and self-diagnosis is not to be executed after release from the reset state, wait for a time corresponding to that required to execute self-diagnosis and then generate a self-diagnostic BIST reset so that the transition to the state of running the user-created program is possible.
10. A reset during the self-diagnosis BIST in debugging mode cannot be masked by the settings of the debugger.
11. In debugging mode, a reset cannot be performed during the period where the HEAPCLK is stopped (during the flash reset sequence, PLL lockup time, and OSC stabilization time). Execute a reset operation during the period other than that where the HEAPCLK is stopped.

(2) Using the Single-Pin Debugging Interface

1. Handling of devices used for debugging
Do not mount a device that was used in debugging on a mass-produced product, because the rewriting of flash memory during debugging will mean that the number of times flash memory is rewritable cannot be guaranteed.
2. Keep the $\overline{\text{DCUTRST}}$ pin at the low level after release from the reset state (i.e. do not change the level back from low to high once the $\overline{\text{DCUTRST}}$ pin is set to the high level). This product supports the Nexus debugging interface and single-pin debugging interface, but does not support changing the debugging interface during on-chip debugging. To change the debugging interface, set the RESET and $\overline{\text{DCUTRST}}$ pins to the low level, and then turn the power supply off and on.
3. Terminating operations in on-chip debugging mode under any of the following conditions causes operation to become undefined. After terminating operations in on-chip debugging mode, place the low level on the RESET and $\overline{\text{DCUTRST}}$ pins so that the start-up sequence for Nexus is executed again.
 - Power supply being turned off
 - High level on the $\overline{\text{DCUTRST}}$ pin
 - On-chip debugging ID code did not match (comparison always proceeds, i.e. is not only performed once)
 - High level on the FLMD0 pin and low level on the $\overline{\text{RESET}}$ pin
4. Debugging is suspended if the low level is input on the $\overline{\text{RESET}}$ pin while the FLMD0 pin is at the high level (used for self-programming, etc.) in the on-chip debugging mode. Re-apply the high level on the $\overline{\text{RESET}}$ pin while the FLMD0 pin is at the low level.
5. Starting communications by placing the low level on the LPDIO pin during BIST stops communications with the tool. Only start communications with the microcomputer after BIST has been executed.
6. If a reset ($\overline{\text{RESET}}$, $\overline{\text{WDTA0RES}}$, $\overline{\text{CLMA0RES}}$ to $\overline{\text{CLMA2RES}}$, $\overline{\text{LVIRES}}$, $\overline{\text{SGARES}}$, $\overline{\text{DBRES}}$) is generated after the tool starts communication but before the on-chip debugging ID is verified, the tool may not communicate with the microcomputer. In such cases, apply the low level on the $\overline{\text{DCUTRST}}$ pin, and then turn the power supply off and on.
7. When the external reset signal goes to the active level during on-chip debugging, the ERROROUT pin is fixed to the low level (when the external reset signal becomes active in single-chip mode, the ERROROUT pin will also go to the low level).
8. When a reset is produced by $\overline{\text{RESET}}$, $\overline{\text{WDTA0RES}}$, $\overline{\text{CLMA0RES}}$ to $\overline{\text{CLMA2RES}}$, $\overline{\text{LVIRES}}$, $\overline{\text{SGARES}}$, or $\overline{\text{DBRES}}$ during on-chip debugging and self-diagnosis is not to be executed after release from the reset state, wait for a time corresponding to that required to execute self-diagnosis and then generate a self-diagnostic BIST reset so that the transition to the state of running the user-created program is possible.
9. After the rate of the clock for communications during single-pin debugging is changed from low to high by the tool, do not lower the clock rate again. Operation is not guaranteed if this is attempted.
10. The CPU clock setting should not be changed in on-chip debugging mode; otherwise debugging cannot continue.

11. A reset during the self-diagnosis BIST in debugging mode cannot be masked by the settings of the debugger.
12. In debugging mode, a reset cannot be performed during the period where the HEAPCLK is stopped (during the flash reset sequence, PLL lockup time, and OSC stabilization time). Execute a reset operation during the period other than that where the HEAPCLK is stopped.

Section 26 Power Supply Configuration

This product includes regulators for the power supplies as illustrated in the flowing figure.

Connect a capacitor to the REGCn pins for the regulators to stabilize their output. The regulators operate whenever the power supply is turned on.

(1) List of Pins

The following table lists the pins used for the power supply.

Table 26-1 List of Pins Used for the Power Supply

Pin Name	Function	Pin Number
EVDD	Power supply for flash memory and external pins	25, 59, 60, 98
VDD	Power supply for internal regulators and POF/LVI	CREG: 7 Main: 8, 36, 65, 96
OSCVDD	Power supply for the oscillator	15
AVDD	Power supply for the AD converter	76
REGC0	Pin for connecting the capacitor for the internal regulator (for CREG)	5
REGC1	Pin for connecting the capacitor for the internal regulator (for the main power supply)	10

(2) Schematic Diagram of the Power Supply Configuration

The following figure shows the schematic diagram of the power supply configuration

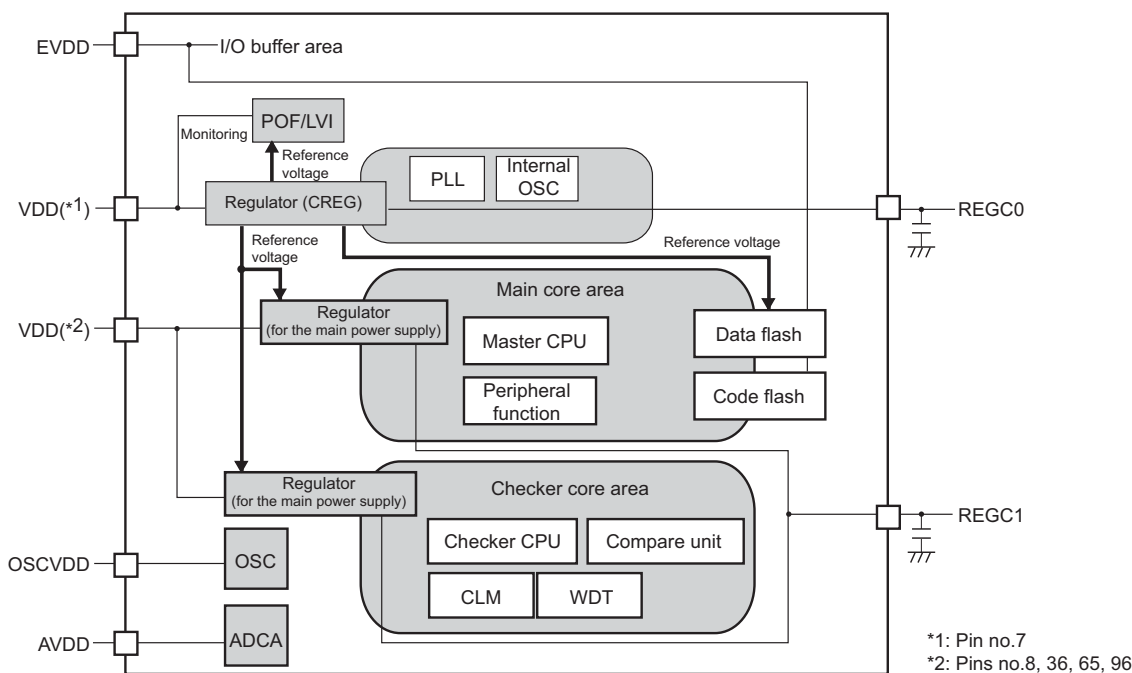

Figure 26-1 Schematic Diagram of the Power Supply Configuration

Section 27 Electrical Characteristics

27.1 Absolute Maximum Ratings

($T_a = 25^\circ\text{C}$)

Item	Symbol	Conditions	Ratings	Unit
Power supply voltage	V_{DD}	$V_{DD} = EV_{DD} = OSCV_{DD}$	-0.3 to +6.0	V
	EV_{DD}	$V_{SS} = EV_{SS} = OSCV_{SS} = AV_{SS0} = 0\text{ V}$	-0.3 to +6.0	V
	$OSCV_{DD}$		-0.3 to +6.0	V
	AV_{DD0}	$V_{SS} = EV_{SS} = OSCV_{SS} = AV_{SS0} = 0\text{ V}$	-0.3 to +6.0	V
Input voltage	V_I	$V_{SS} = EV_{SS} = OSCV_{SS} = AV_{SS0} = 0\text{ V}$	-0.3 to $EV_{DD}+0.3^{*1}$	V
Analog input voltage	V_{IAN}	ADCA011 to ADCA018 $V_{SS} = EV_{SS} = OSCV_{SS} = AV_{SS0} = 0\text{ V}$	-0.3 to $AV_{DD0}+0.3^{*1}$	V
	AV_{REF0P}	ADCA011 to ADCA018 $V_{SS} = EV_{SS} = OSCV_{SS} = AV_{SS0} = 0\text{ V}$	-0.3 to $AV_{DD0}+0.3^{*1}$	V
	AV_{REF0M}	ADCA011 to ADCA018 $V_{SS} = EV_{SS} = OSCV_{SS} = AV_{SS0} = 0\text{ V}$	-0.3 to $AV_{DD0}+0.3^{*1}$	V
High-level output current	I_{OH}	1 pin	-10	mA
		Total pins	-50	mA
Low-level output current	I_{OL}	1 pin	10	mA
		Total pins	50	mA
Operating ambient temperature	T_a		-40 to +125	$^\circ\text{C}$
Storage temperature	T_{stg}	$T_a = T_j$	-55 to +125	$^\circ\text{C}$

Note Be sure not to exceed the absolute maximum ratings of each supply voltage.

-
- Caution 1. Make sure that the total the current flowing through these pins and output currents does not exceed 50 mA.
- Caution 2. Do not directly connect output (or I/O) pins of IC products to each other, or to V_{DD} , V_{CC} , and GND. Open drain pins or open collector pins, however, can be directly connected to each other. Direct connection of the output pins between an IC product and an external circuit is possible if the output pins can be set to the high-impedance state and the output timing of the external circuit is designed to avoid output conflict.
- Caution 3. Product quality may suffer if the absolute maximum rating is exceeded even momentary for any parameter. That is, the absolute maximum ratings are rated values at which the product is on the verge of suffering physical damage, and therefore the product must be used under conditions that ensure that the absolute maximum ratings are not exceeded. The ratings and conditions shown below for DC characteristics and AC characteristics are within the range for normal operation and quality assurance.
-

27.2 Capacity

($T_a = 25^\circ\text{C}$, $V_{DD} = EV_{DD} = OSCV_{DD} = AV_{DD} = V_{SS} = EV_{SS} = OSCV_{SS} = AV_{SS0} = 0\text{ V}$)

Item	Symbol	Conditions	MIN.	TYP.	MAX.	Unit
Input capacitance	C_I	$f_C = 1\text{ MHz}$ 0 V for non-measured pins, and excluding analog pins selected for use with S/H channels or AD converter channels.			15	pF
I/O capacitance	C_{IO}				15	pF
Output capacitance	C_O				15	pF

27.3 Operating Conditions

($T_a = -40\text{ to }+125^\circ\text{C}$, $V_{SS} = EV_{SS} = OSCV_{SS} = AV_{SS0} = 0\text{ V}$)

Internal Operation Clock Frequency	Operating Ambient Temperature (T_a)	Power Supply Voltage
$f_{xx} = 48\text{ MHz}$	$T_a = -40\text{ to }+125^\circ\text{C}$	$V_{DD} = EV_{DD} = OSCV_{DD} = 3.0\text{ to }5.5\text{ V}$ $AV_{DD0} = 4.2\text{ to }5.5\text{ V}$
$f_{xx} = 64\text{ MHz}$		
$f_{xx} = 80\text{ MHz}$		

27.4 Characteristics of Oscillation Circuit

27.4.1 Characteristics of Oscillation Circuit

($T_a = -40$ to $+125^\circ\text{C}$, $V_{DD} = EV_{DD} = OSCV_{DD} = 3.0$ to 5.5 V,
 $AV_{DD0} = 4.2$ to 5.5 V, $V_{SS} = EV_{SS} = OSCV_{SS} = AV_{SS0} = 0$ V)

Item	Symbol	Conditions	MIN.	TYP.	MAX.	Unit
Oscillation frequency	fx	$\mu\text{PD70F4155}$	8	8	8	MHz
		$\mu\text{PD70F4154}$	16	16	16	MHz

- Caution 1. The figure below shows the characteristics of oscillation circuit only. When placing wiring in the area enclosed by the broken line in the figure below during the design of the oscillator, avoid adverse effects from wiring capacitance by following the directions below.

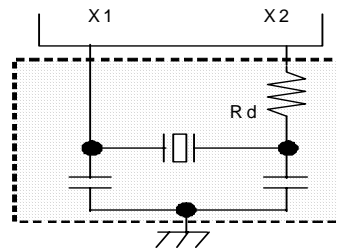

- Bring the oscillation circuit as close as possible to the X1 and X2 terminals.
 - Do not pass other signal conductors through the broken line part in the above figure.
 - Do not route the wiring near signal lines through which a high fluctuating current flows.
 - Always make the ground point of the oscillator capacitor the same potential as $OSCV_{SS}$.
 - Do not ground the capacitor to a ground pattern through which a high current flows.
 - Do not fetch signals from the oscillator.
- Caution 2. When selecting the crystal oscillator, designing the parameters of the oscillation circuit, or calculating the time required for oscillation to become stable, exhaustively evaluate the finished system for matching of the device and the oscillator or ask the manufacturer of the oscillator to do so.

27.4.2 Characteristics of Internal Oscillation Circuit

($T_a = -40$ to $+125^\circ\text{C}$, $V_{DD} = EV_{DD} = OSCV_{DD} = 3.0$ to 5.5 V,
 $AV_{DD0} = 4.2$ to 5.5 V, $V_{SS} = EV_{SS} = OSCV_{SS} = AV_{SS0} = 0$ V)

Item	Symbol	Conditions	MIN.	TYP.	MAX.	Unit
Internal oscillation frequency	f_{ROSC}		7.2	8	8.8	MHz

27.5 DC Characteristics

DC Characteristics (1/3)

($T_a = -40$ to $+125^\circ\text{C}$, $V_{DD} = EV_{DD} = OSCV_{DD} = 3.0$ to 5.5 V,
 $AV_{DD0} = 4.2$ to 5.5 V, $V_{SS} = EV_{SS} = OSCV_{SS} = AV_{SS0} = 0$ V)

Item	Symbol	Conditions	MIN.	TYP.	MAX.	Unit
High-level input voltage	V_{IH1}	Port pins, FLMD0 pin	$0.7 \times EV_{DD}$		$EV_{DD} + 0.3$	V
	V_{IH2}	FLMD1 pin, JP0_1 - JP0_3, JP0_5	$0.8 \times EV_{DD}$		$EV_{DD} + 0.3$	V
	V_{IH3} *6, *7	DCUTDI, DCUTMS DCUTCK, $\overline{DCUTRST}$	2.2		$EV_{DD} + 0.3$	V
	V_{IH4} *6, *8	DCUTDI, DCUTMS DCUTCK, $\overline{DCUTRST}$	2.0		$EV_{DD} + 0.3$	V
	V_{IH5}	\overline{RESET} pin	$0.8 \times EV_{DD}$		$EV_{DD} + 0.3$	V
Low-level input voltage	V_{IL1}	Port pins, FLMD0 pin	-0.3		$0.3 \times EV_{DD}$	V
	V_{IL2}	FLMD1 pin, JP0_1 - JP0_3, JP0_5	-0.3		$0.2 \times EV_{DD}$	V
	V_{IL3} ^{*6}	DCUTDI, DCUTMS DCUTCK	-0.3		0.8	V
	V_{IL4}	\overline{RESET} pin, $\overline{DCUTRST}$	-0.3		0.6	V
Hysteresis width* ¹	V_{HYS1}	Port pins, FLMD0 pin		0.5		V
	V_{HYS2}	FLMD1 pin		0.8		V
	V_{HYS3}	\overline{RESET} pin		0.8		V
High-level output voltage* ²	V_{OH1}	$I_{OH} = -3$ mA	$EV_{DD} - 1.0$		EV_{DD}	V
		$I_{OH} = -1$ mA	$EV_{DD} - 1.0$		EV_{DD}	V
		$I_{OH} = -0.1$ mA	$EV_{DD} - 0.5$		EV_{DD}	V
Low-level output voltage* ²	V_{OL1}	$I_{OL} = 3$ mA	0		0.4	V
		$I_{OL} = 1$ mA	0		0.4	V
		$I_{OL} = 25$ mA* ⁹	0		0.25	V
Pull-up resistor	R_1	$V_I = 0$ V, other than for the pins below	15	33	150	K Ω
	R_2	$V_I = 0$ V* ³	10	19	80	K Ω
Pull-down resistor	R_3	$V_I = EV_{DD}$ * ⁴	15	33	150	K Ω
	R_4	$V_I = EV_{DD}$ * ⁵	25	53	200	K Ω
	R_5	$V_I = EV_{DD}$ * ³	10	19	80	K Ω

Note 1. When the operation of an adjacent pin is halted.

Note 2. Make sure that the total current flowing through these pins and output currents does not exceed 50 mA.

Note 3. Only for the FLMD0 pin

Note 4. Only for the FLMD1 and $\overline{DCUTRST}$ pins

Note 5. Only for the \overline{RESET} pin

Note 6. In debugging mode

Note 7. $EV_{DD} = 4.5$ to 5.5 V

Note 8. $EV_{DD} = 3.0$ to 4.5 V

Note 9. LPDIO pin, $EV_{DD} = 4.0$ to 5.5 V

Caution The characteristics of the alternative function pins are the same as those of the port pin unless otherwise specified.

DC Characteristics (2/3)

($T_a = -40$ to $+125^\circ\text{C}$, $V_{DD} = EV_{DD} = OSCV_{DD} = 3.0$ to 5.5 V,
 $AV_{DD0} = 4.2$ to 5.5 V, $V_{SS} = EV_{SS} = OSCV_{SS} = AV_{SS0} = 0$ V)

Item	Symbol	Condition	MIN.	TYP.	MAX.	Unit
High-level input leakage current	I_{LIH1}	$V_{IAN} = AV_{DD0}$			0.3	μA
		$V_1 = EV_{DD}$			40	μA
		$V_1 = EV_{DD}$			5	μA
Low-level input leakage current	I_{LIL1}	$V_{IAN} = 0$ V			-0.3	μA
		$V_1 = 0$ V			-40	μA
		$V_1 = 0$ V			-5	μA
High-level output leakage current	I_{LOH1}	$V_1 = EV_{DD}$			5	μA
Low-level output leakage current	I_{LOL1}	$V_1 = 0$ V			-5	μA

Note 1. ADCA011 to ADCA018

This indicates the leakage current when the A/D conversion is not being performed at the target pins.

Note 2. The current flowing through the pull-up/pull-down resistors is not included.

Note 3. Port pins, JP0_1 to JP0_3, and JP0_5

Note 4. Port pins, JP0_1 to JP0_3, and JP0_5, FLMD1 pin, $\overline{\text{DCUTRST}}$ pin, and RESET pin

DC Characteristics (3/3)

($T_a = -40$ to $+125^\circ\text{C}$, $V_{DD} = EV_{DD} = OSCV_{DD} = 3.0$ to 5.5 V,
 $AV_{DD0} = 4.2$ to 5.5 V, $V_{SS} = EV_{SS} = OSCV_{SS} = AV_{SS0} = 0$ V)

Item	Symbol	Conditions	MIN.	TYP.	MAX.	Unit		
Power-supply current*1	I_{DD}	Internal power supply current (V_{DD})	fxx = 48 MHz	PCLK = 1/1HEAPCLK		55	115	mA
				PCLK = 1/2HEAPCLK		47	100	mA
			fxx = 64 MHz	PCLK = 1/1HEAPCLK		72	150	mA
				PCLK = 1/2HEAPCLK		63	130	mA
			fxx = 80 MHz	PCLK = 1/1HEAPCLK		90	185	mA
				PCLK = 1/2HEAPCLK		79	160	mA
	I_{DDE}	External power supply current ($EV_{DD} + OSCV_{DD}$)				15	mA	
	When rewriting flash memory	I_{DDF}	Internal power supply current (V_{DD})				95	mA
		I_{DDE}	External power supply current ($EV_{DD} + OSCV_{DD}$)				86	mA
	When executing BIST	I_{DDB}	Internal power supply current (V_{DD})	fxx = 48 MHz		56	110	mA
				fxx = 64 MHz		75	145	mA
				fxx = 80 MHz		94	180	mA
I_{DDE}		External power supply current ($EV_{DD} + OSCV_{DD}$)				15	mA	
At reset*2	I_{DDR}	Internal power supply current (V_{DD})				30	mA	
	I_{DDE}	External power supply current ($EV_{DD} + OSCV_{DD}$)				15	mA	

Note 1. I_{DDE} is the current flowing through $EV_{DD}/OSCV_{DD}$. However, it does not include the current flowing through the pull-up/pull-down resistors, nor the port toggle current. For details on the current flowing through AV_{DD0} , refer to section 27.6.15, A/D Converter Characteristics.

Note 2. The current in the transient state at power on is not included. It indicates the reset current when the internal power supply is stable.

Caution Make sure that the total current flowing through these pins and output currents does not exceed 50 mA.

Note MAX. is the maximum value over temperature, voltage range, and manufacturing condition.

The current when executing BIST is the average current when executing BIST.

27.6 AC Characteristics

27.6.1 Measurement Conditions

Input waveform for AC testing



AC test output measurement points

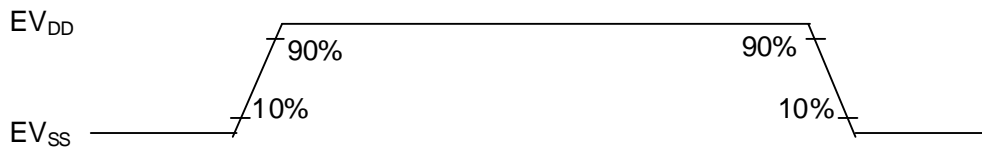

Load conditions

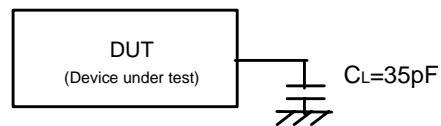

Caution If the load capacitance exceeds 35 pF due to the circuit configuration, bring the load capacitance of the device to 35 pF or less by inserting a buffer or by some other means.

27.6.2 Clock Timing (CLKOUT)

($T_a = -40$ to $+125^\circ\text{C}$, $V_{DD} = EV_{DD} = OSCV_{DD} = 3.0$ to 5.5 V,
 $AV_{DD0} = 4.2$ to 5.5 V, $V_{SS} = EV_{SS} = OSCV_{SS} = AV_{SS0} = 0$ V)

Item	Symbol	Conditions	MIN.	MAX.	Unit
CLKOUT output cycle time	t_{CYK}		0.05	512	μs
CLKOUT high level width	t_{WKH}		$t_{CYK}/2 - 15$		ns
CLKOUT low level width	t_{WKL}		$t_{CYK}/2 - 15$		ns
CLKOUT rise time	t_{KR}			15	ns
CLKOUT fall time	t_{KF}			15	ns

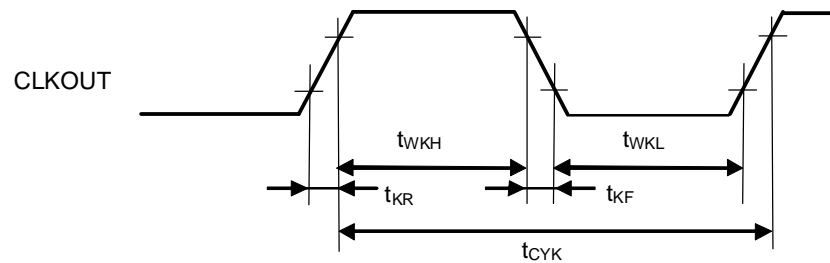

27.6.3 Timing in Turning the Power Supply On and Off

($T_a = -40$ to $+125^\circ\text{C}$, $V_{DD} = EV_{DD} = OSCV_{DD} = 3.0$ to 5.5 V,
 $AV_{DD0} = 4.2$ to 5.5 V, $V_{SS} = EV_{SS} = OSCV_{SS} = AV_{SS0} = 0$ V)

Item	Symbol	Conditions	MIN.	MAX.	Unit
Voltage slope (V_{DD}) \uparrow	t_{RAA}	0 V to 3 V	0.5 V/ms	0.15 V/us	-
$V_{DD}\uparrow$ to $AV_{DD0}\uparrow$	t_{RIA}	$V_{DD} = EV_{DD} = OSCV_{DD}$	0	1000	ms
$AV_{DD0}\uparrow$ to $V_{DD}\uparrow$	t_{RAI}	$V_{DD} = EV_{DD} = OSCV_{DD}$	0	1000	ms
$V_{DD}\uparrow$ to $\overline{RESET}\uparrow$	t_{RIR}	$V_{DD} = EV_{DD} = OSCV_{DD}^{*1}$	$t_{OSC} + T_{d_pof} + 0.5$		ms
$AV_{DD0}\uparrow$ to $\overline{RESET}\uparrow$	t_{RAR}	*1	$t_{OSC} + 0.5$		ms
FLMD1,0 setup time (to $\overline{RESET}\uparrow$)	t_{RMR0}		0		ns
FLMD1,0 hold time (to $\overline{RESET}\downarrow$)	t_{FRM0}	*2	0		ns
$\overline{RESET}\downarrow$ to $V_{DD}\downarrow$	t_{FRI}	$V_{DD} = EV_{DD} = OSCV_{DD}$	500		ns
$\overline{RESET}\downarrow$ to $AV_{DD0}\downarrow$	t_{FRA}		500		ns
$AV_{DD0}\downarrow$ to $V_{DD}\downarrow$	t_{FAI}	$V_{DD} = EV_{DD} = OSCV_{DD}$	0	1000	ms
$V_{DD}\downarrow$ to $AV_{DD0}\downarrow$	t_{FIA}	$V_{DD} = EV_{DD} = OSCV_{DD}$	0	1000	ms

Note 1. t_{OSC} : Oscillation stabilization time. T_{d_pof} : POF detection delay time.

Note 2. Using the specified value is recommended for the FLMD1, 0 hold time (time until \overline{RESET} falls: t_{FRM0}). If using the recommended value is difficult, change the FLMD1, 0 pins once rewriting of the flash memory is complete.

-
- Caution 1. Turn on/off V_{DD} , EV_{DD} , and $OSCV_{DD}$ at the same time.
- Caution 2. Apply an external reset (\overline{RESET}) whenever the power supply voltage falls below the operating voltage.
- Caution 3. The voltage should be applied to AV_{REF0P} after power is supplied to AV_{DD0} (or at the same time).
 ($AV_{REF0P} \leq AV_{DD0}$)
- Caution 4. The power to AV_{REF0P} should be shut down before the power to AV_{DD0} is shut down (or at the same time).
 ($AV_{REF0P} \leq AV_{DD0}$)
-

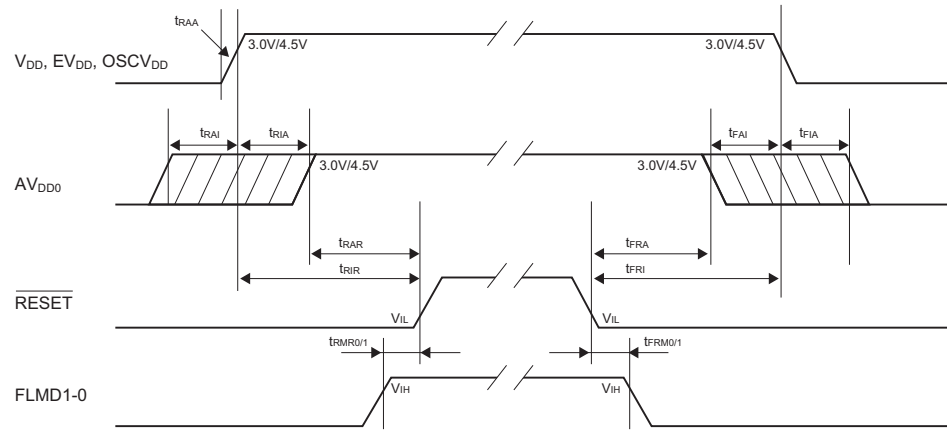

27.6.4 Regulator Characteristics

($T_a = -40$ to $+125^\circ\text{C}$, $V_{DD} = EV_{DD} = OSCV_{DD} = 3.0$ to 5.5 V,
 $AV_{DD0} = 4.2$ to 5.5 V, $V_{SS} = EV_{SS} = OSCV_{SS} = AV_{SS0} = 0$ V)

Item	Symbol	Conditions	MIN.	TYP.	MAX.	Unit
Input voltage	V_{DD}		3.0		5.5	V
Output voltage (CREG)	V_{RO0}		1.35	1.5	1.65	V
Output voltage (main)	V_{RO1}		1.35	1.5	1.65	V
REGC0 capacity	REGC0		3.29	4.7	6.11	μF
REGC1 capacity	REGC1		0.07	0.1	0.13	μF
Output voltage stabilization time (CREG)	R_{AVS0}				1	ms
Output voltage stabilization time (main)	R_{AVS1}				200	μs

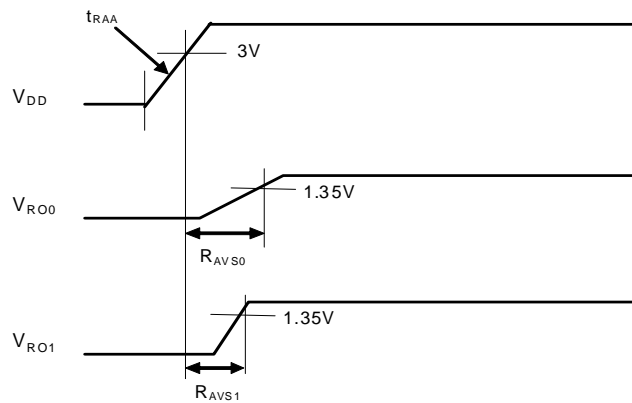

Caution Select an appropriate condenser to be connected with REGC0 and REGC1 after fully evaluating.

27.6.5 Reset Timing

($T_a = -40$ to $+125^\circ\text{C}$, $V_{DD} = EV_{DD} = OSCV_{DD} = 3.0$ to 5.5 V,
 $AV_{DD0} = 4.2$ to 5.5 V, $V_{SS} = EV_{SS} = OSCV_{SS} = AV_{SS0} = 0$ V)

Item	Symbol	Conditions	MIN.	MAX.	Unit
$\overline{\text{RESET}}$ input low level width	t_{WRSL}	Other than power supply turning on	500		ns

Caution The above values are for pulse widths that ensure detection of an effective edge. An effective edge may also be detected even if the input pulse width is less than the above specification.

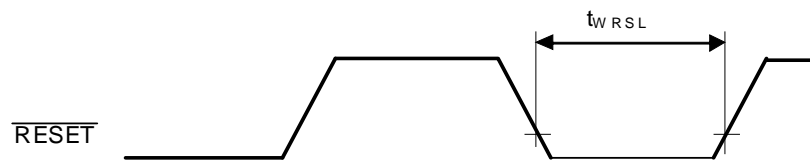

27.6.6 Interrupt Timing

($T_a = -40$ to $+125^\circ\text{C}$, $V_{DD} = EV_{DD} = OSCV_{DD} = 3.0$ to 5.5 V,
 $AV_{DD0} = 4.2$ to 5.5 V, $V_{SS} = EV_{SS} = OSCV_{SS} = AV_{SS0} = 0$ V)

Item	Symbol	Conditions	MIN.	MAX.	Unit
NMI input high-level width	t_{WNIH}	Digital filter	*1		ns
NMI input low-level width	t_{WNIL}	Digital filter	*1		ns
INTPn input high-level width	t_{WITh}	Digital filter	*1		ns
INTPn input low-level width	t_{WITL}	Digital filter	*1		ns

Note 1. $i \times T_{\text{samp}} + 10$ (T_{samp} is the interval of the noise rejection sampling clocks, $i = 2, 3, 4, 5$)

Caution The above values are for pulse widths that ensure detection of an effective edge. An effective edge may also be detected even if the input pulse width is less than the above specification.

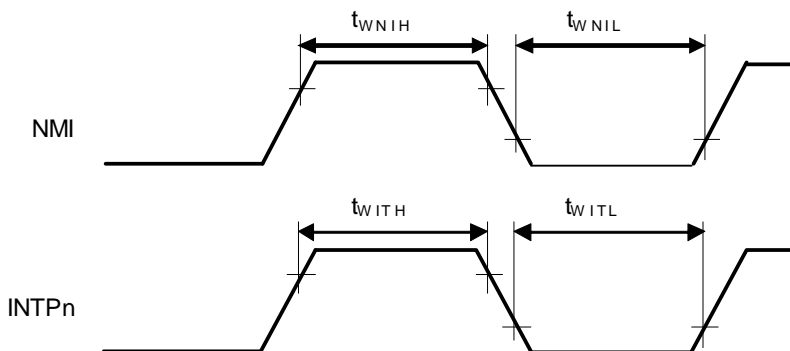

Note n = 0 to 9

27.6.7 ESON Timing

($T_a = -40$ to $+125^\circ\text{C}$, $V_{DD} = EV_{DD} = OSCV_{DD} = 3.0$ to 5.5 V,
 $AV_{DD0} = 4.2$ to 5.5 V, $V_{SS} = EV_{SS} = OSCV_{SS} = AV_{SS0} = 0$ V)

Item	Symbol	Conditions	MIN.	MAX.	Unit
ESOn input high-level width	t_{WESOH}	Analog filter	500		ns
ESOn input low-level width	t_{WESOL}	Analog filter	500		ns

Caution The above values are for pulse widths that ensure detection of an effective edge. An effective edge may also be detected even if the input pulse width is less than the above specification.

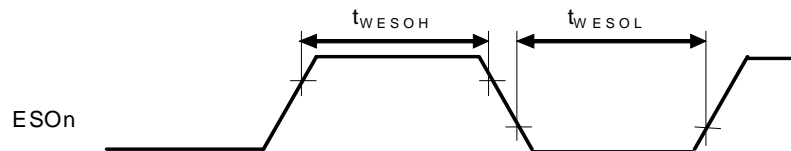

Note $n = 0$ or 2

27.6.8 ADCA0TRGn Timing

($T_a = -40$ to $+125^\circ\text{C}$, $V_{DD} = EV_{DD} = OSCV_{DD} = 3.0$ to 5.5 V,
 $AV_{DD0} = 4.2$ to 5.5 V, $V_{SS} = EV_{SS} = OSCV_{SS} = AV_{SS0} = 0$ V)

Item	Symbol	Conditions	MIN.	MAX.	Unit
ADCA0TRGn input high-level width	t_{WADTH}	Analog filter	500		ns
ADCA0TRGn input low-level width	t_{WADTL}	Analog filter	500		ns

Caution The above values are for pulse widths that ensure detection of an effective edge. An effective edge may also be detected even if the input pulse width is less than the above specification.

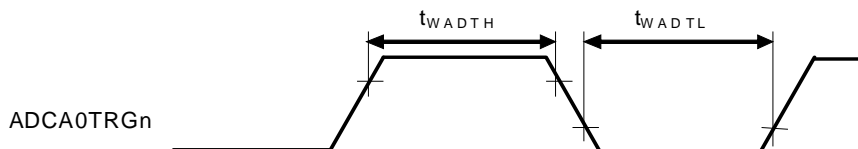

Note n = 0 to 2

27.6.9 Timer Timing

($T_a = -40$ to $+125^\circ\text{C}$, $V_{DD} = EV_{DD} = OSCV_{DD} = 3.0$ to 5.5 V,
 $AV_{DD0} = 4.2$ to 5.5 V, $V_{SS} = EV_{SS} = OSCV_{SS} = AV_{SS0} = 0$ V)

Item	Symbol	Conditions	MIN.	MAX.	Unit
TI input high level width	t_{TIH}	TAUB0I0-15, TAUJ0I0-3, TSG20PTSI0-2, ENCA0E0,1, ENCA0EC	*1		ns
TI input low level width	t_{TIL}	TAUB0I0-15, TAUJ0I0-3, TSG20PTSI0-2, ENCA0E0,1, ENCA0EC	*1		ns
TO output cycle time	t_{TCYK}	TAUB0O0-15, TAUJ0O0-3, OSTM0O, OSTM1O TSG20O1-7, TPB0O	80		ns

Note 1. $i \times T_{\text{samp}} + 10$ (T_{samp} is the interval of the noise rejection sampling clocks,
 $i = 2, 3, 4, 5$)

Caution The above values are for pulse widths that ensure detection of an effective edge. An effective edge may also be detected even if the input pulse width is less than the above specification.

27.6.10 CSIGn Timing

(a) Master Mode

($T_a = -40$ to $+125^\circ\text{C}$, $V_{DD} = EV_{DD} = OSCV_{DD} = 3.0$ to 5.5 V,
 $AV_{DD0} = 4.2$ to 5.5 V, $V_{SS} = EV_{SS} = OSCV_{SS} = AV_{SS0} = 0$ V)

Item	Symbol	Conditions	MIN.	MAX.	Unit
CSIGnSC cycle time*1	t_{KCYM}	Output	125		ns
CSIGnSC high/low level width	t_{KWHM} , t_{KWLM}	Output	$(t_{KCYM}/2) - 20$		ns
CSIGnSI setup time (to CSIGnSC)	t_{SSIM}		30		ns
CSIGnSI hold time (to CSIGnSC)	t_{HSIM}		10		ns
CSIGnSO output delay time (to CSIGnSC)	t_{DSOM}			10	ns
CSIG1RY1 setup time (to CSIG1SC)	t_{SRY1}		$(2 \times t_{PCLK}) + 30$		ns

Note 1. When PCLK < 32 MHz is selected, $1000 / (\text{PCLK cycles}/4)$ [ns]

Note t_{PCLK} : PCLK cycles
 $n = 0, 1$

[CSIGnSC/CSIGnSI/CSIGnSO]

Master mode :
 (CSIGnCTL1 : CSIGnCKR / CSIGnCFG0 : CSIGnDAP = 0 / 0 or 1 / 1)

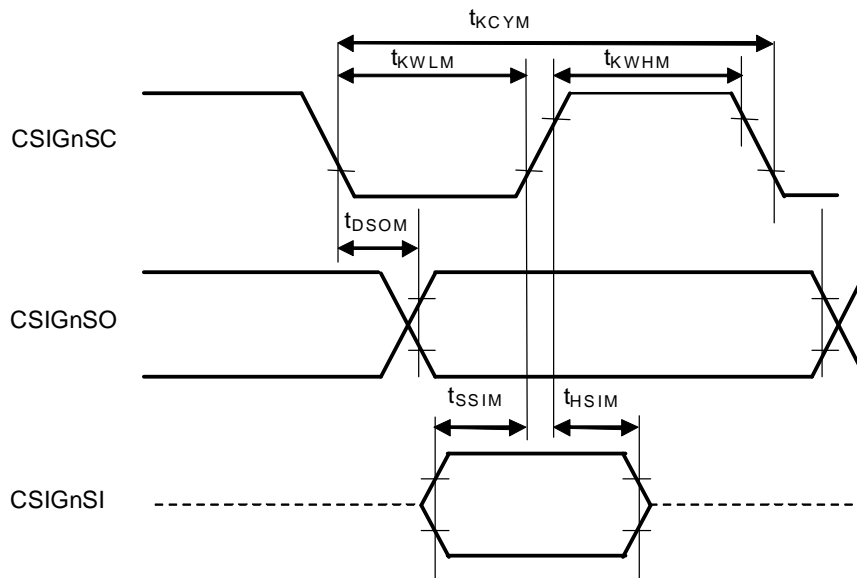

Master mode :
 (CSIGnCTL1 : CSIGnCKR / CSIGnCFG0 : CSIGnDAP = 1 / 0 or 0 / 1)

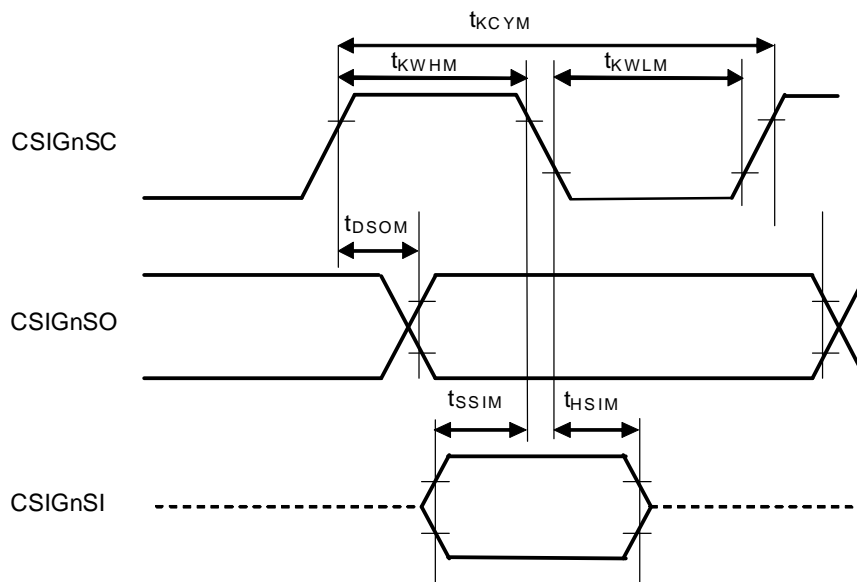

Note n = 0, 1

[CSIGnSC/ CSIGnRYI]

Master mode : (CSIGnCTL1 : CSIGnCKR = 0)

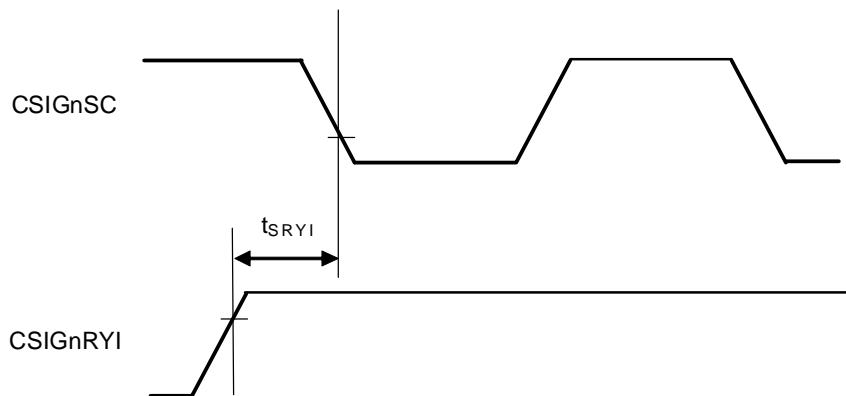

Master mode : (CSIGnCTL1 : CSIGnCKR = 1)

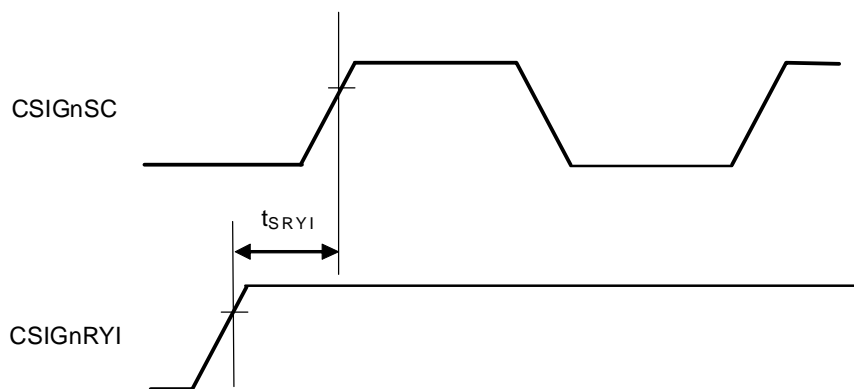

Note n = 0, 1

(b) Slave Mode

($T_a = -40$ to $+125^\circ\text{C}$, $V_{DD} = EV_{DD} = OSCV_{DD} = 3.0$ to 5.5 V,
 $AV_{DD0} = 4.2$ to 5.5 V, $V_{SS} = EV_{SS} = OSCV_{SS} = AV_{SS0} = 0$ V)

Item	Symbol	Conditions	MIN.	MAX.	Unit
CSIGnSC cycle time*1	t_{KCYS}	Input	150		ns
CSIGnSC high/low level width	t_{KWHS} , t_{KWLS}	Input	$(t_{KCYS}/2) - 20$		ns
CSIGnSI setup time (to CSIGnSC)	t_{SSIS}		15		ns
CSIGnSI hold time (to CSIGnSC)	t_{HSIS}		$t_{PCLK} + 10$		ns
CSIGnSO output delay time (to CSIGnSC)	t_{DSOS}			30	ns
CSIG1RYO output delay	t_{SRYO}			30	ns

Note 1. When PCLK < 48 MHz is selected, $1000 / (\text{PCLK cycles}/6)$ [ns]

Note t_{PCLK} : PCLK cycles
 $n = 0, 1$

[CSIGN_nSC / CSIGN_nSI/CSIGN_nSO]

Slave mode :
 (CSIGN_nCTL1 : CSIGN_nCKR / CSIGN_nCFG0 : CSIGN_nDAP = 0 / 0 or 1 / 1)

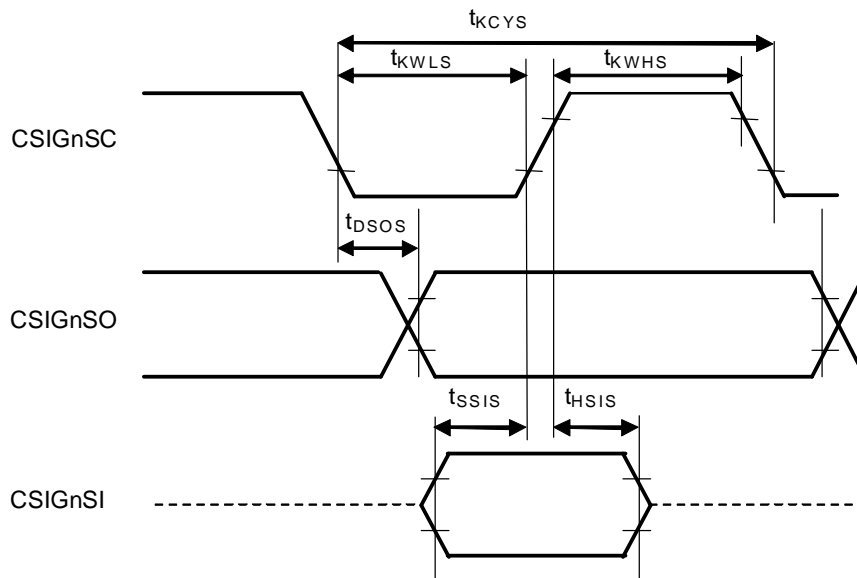

Slave mode :
 (CSIGN_nCTL1 : CSIGN_nCKR / CSIGN_nCFG0 : CSIGN_nDAP = 1 / 0 or 0 / 1)

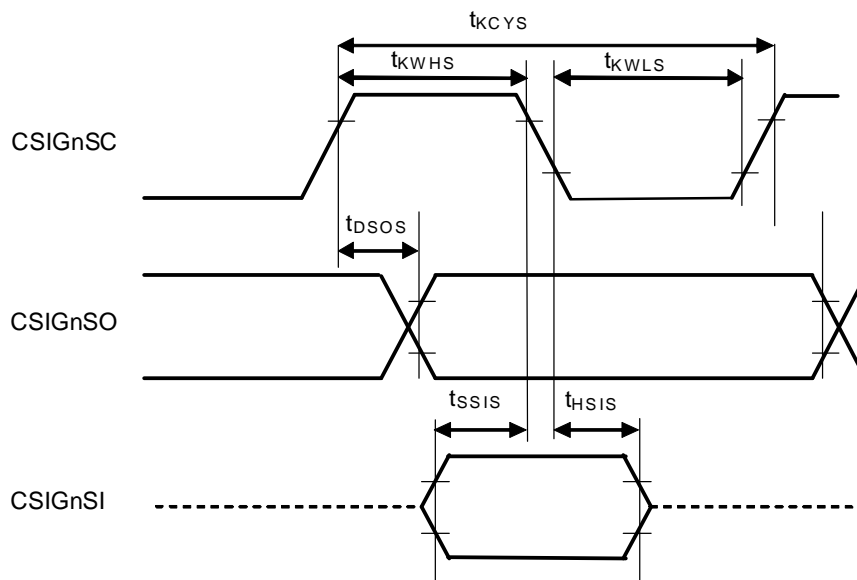

Note n = 0, 1

[CSIGnSC/CSIGnRYO]

(CSIGnCTL1 : CSIGnCKR / CSIGnCFG0 : CSIGnDAP = 0 / 0 or 1 / 1)

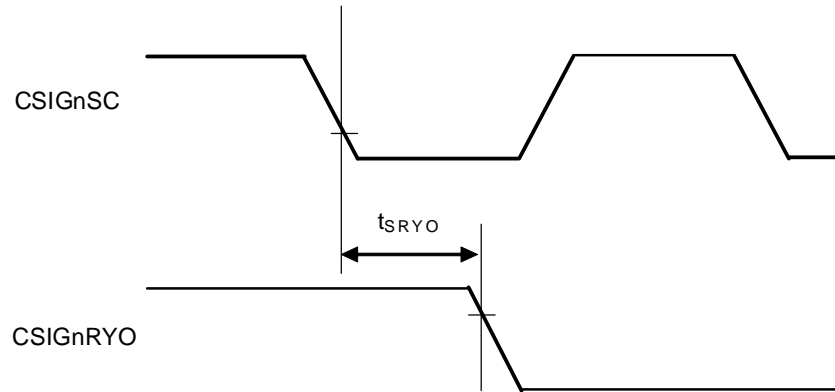

(CSIGnCTL1 : CSIGnCKR / CSIGnCFG0 : CSIGnDAP = 0 / 1 or 1 / 0)

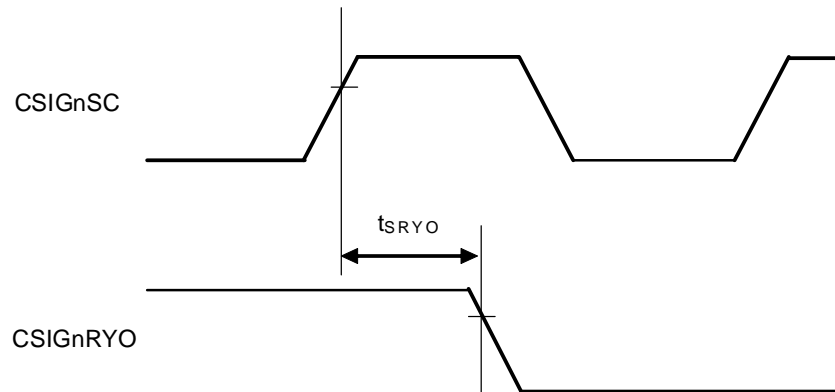

Note n = 0, 1

27.6.11 UARTHn Timing

(a) Asynchronous Mode

($T_a = -40$ to $+125^\circ\text{C}$, $V_{DD} = EV_{DD} = OSCV_{DD} = 3.0$ to 5.5 V,
 $AV_{DD0} = 4.2$ to 5.5 V, $V_{SS} = EV_{SS} = OSCV_{SS} = AV_{SS0} = 0$ V)

Item	Symbol	Conditions	MIN.	MAX.	Unit
UARTHn transfer rate				2	Mbps
URTHnCTS setup time (to URTHnTXD)	t_{ASCTS}	Input	URTHnCTS without noise filter	$3T+30$	ns
			URTHnCTS with noise filter	$5T+30$	ns
URTHnRTS output delay time (to URTHnRXD)	t_{ASRTS}	Output	URTHnRXD without noise filter		$(3BRS+2)T+ 30$
			URTHnRXD with noise filter		$(3BRS+4)T+ 30$

Note n = 0, 1

T = Prescaler cycle time

BRS: Setting of URTHnCTL2.URTHnBRS[11:0]

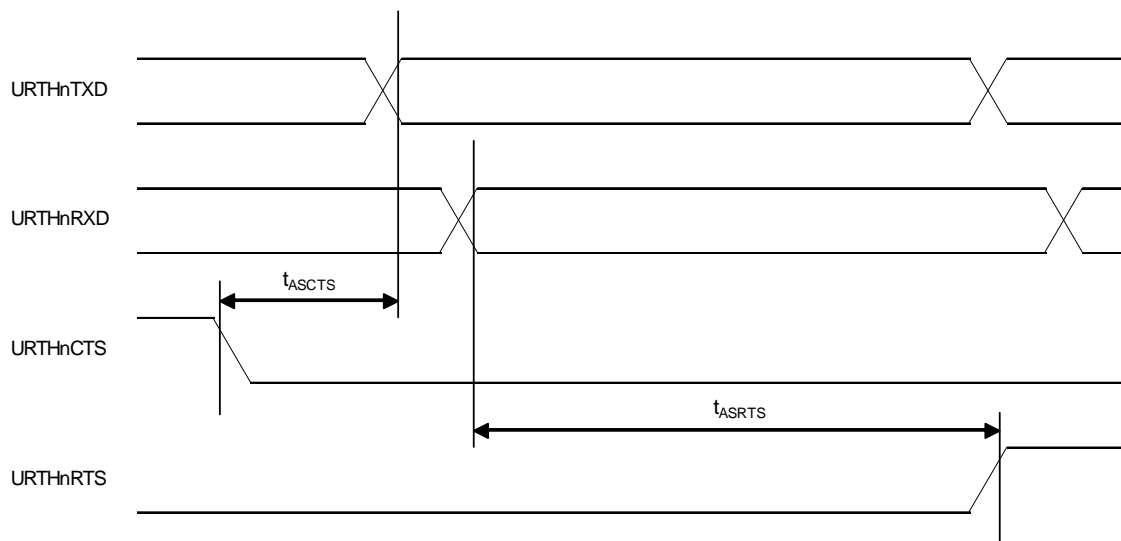

(b) Clock Synchronous, Master Mode (Normal Mode)

($T_a = -40$ to $+125^\circ\text{C}$, $V_{DD} = EV_{DD} = OSCV_{DD} = 3.0$ to 5.5 V,
 $AV_{DD0} = 4.2$ to 5.5 V, $V_{SS} = EV_{SS} = OSCV_{SS} = AV_{SS0} = 0$ V)

Item	Symbol	Conditions	URTHnRXD without Noise Filter		URTHnRXD with Noise Filter		Unit
			MIN.	MAX.	MIN.	MAX.	
URTHnSC cycle time	t_{KCYM1}	Output	500		500		ns
URTHnSC high level width	t_{KWHM1}	Output	$t_{KCYM1}/2-20$		$t_{KCYM1}/2-20$		ns
URTHnSC low level width	t_{KWLM1}	Output	$t_{KCYM1}/2-20$		$t_{KCYM1}/2-20$		ns
URTHnRXD setup time (to URTHnSC \uparrow)	t_{SRXDM1}	Input	$T+30$		$3T+30$		ns
URTHnRXD hold time (to URTHnSC \uparrow)	t_{HRXDM1}	Input	0		$-2T$		ns
URTHnTXD output delay time (to URTHnSC \downarrow)	t_{DTXDM1}	Output		10		10	ns
URTHnTXD output hold time (to URTHnSC \uparrow)	t_{HTXDM1}	Output	$t_{KCYM1}/2-10$		$t_{KCYM1}/2-10$		ns
URTHnCTS setup time (to URTHnTXD)	t_{SCTSM1}	Input	URTHnCTS without noise filter	$3T+30$		$3T+30$	ns
			URTHnCTS with noise filter	$5T+30$		$5T+30$	ns
URTHnRTS output delay time (to URTHnRXD)	t_{DRTSM1}	Output		$T+30$		$T+30$	ns

Note $n = 0, 1$

$T =$ Prescaler cycle time

(c) Clock Synchronous, Slave Mode (Normal Mode)

($T_a = -40$ to $+125^\circ\text{C}$, $V_{DD} = EV_{DD} = OSCV_{DD} = 3.0$ to 5.5 V,
 $AV_{DD0} = 4.2$ to 5.5 V, $V_{SS} = EV_{SS} = OSCV_{SS} = AV_{SS0} = 0$ V)

Item	Symbol	Conditions	URTHnSC/URTHnRXD without Noise Filter		URTHnSC/URTHnRXD with Noise Filter		Unit
			MIN.	MAX.	MIN.	MAX.	
URTHnSC cycle time	t_{KCYs1}	Input	500		500		ns
URTHnSC high level width	t_{KWHS1}	Input	$4T-20$		$4T-20$		ns
URTHnSC low level width	t_{KWLS1}	Input	$4T-20$		$4T-20$		ns
URTHnRXD setup time (to URTHnSC \uparrow)	t_{SRXDS1}	Input	10		10		ns
URTHnRXD hold time (to URTHnSC \uparrow)	t_{HRXDS1}	Input	$2T+10$		$2T+10$		ns
URTHnTXD output delay time (to URTHnSC \downarrow)	t_{DTXDS1}	Output		30		30	ns
URTHnTXD output hold time (to URTHnSC \uparrow)	t_{HTXDS1}	Output	$t_{KWHS1}-10$		$t_{KWHS1}-10$		ns
URTHnCTS setup time (to URTHnTXD)	t_{SCTSS1}	Input	URTHnCTS without noise filter	$T+t_{KCYs1}+30$		$-T+t_{KCYs1}+30$	ns
			URTHnCTS with noise filter	$2T+t_{KCYs1}+30$		$T+t_{KCYs1}+30$	ns
URTHnRTS output delay time (to URTHnRXD)	t_{DRTSS1}	Output		$3T+30$		$3T+30$	ns

Note n = 0, 1
 T = Prescaler cycle time

Item	Symbol	Conditions	URTHnSC without Noise Filter URTHnRXD with Noise Filter		URTHnSC with Noise Filter URTHnRXD without Noise Filter		Unit
			MIN.	MAX.	MIN.	MAX.	
URTHnSC cycle time	t_{KCYS1}	Input	500		500		ns
URTHnSC high level width	t_{KWS1}	Input	$4T-20$		$4T-20$		ns
URTHnSC low level width	t_{KWS1}	Input	$4T-20$		$4T-20$		ns
URTHnRXD setup time (to URTHnSC \uparrow)	t_{SRXDS1}	Input	$2T+10$		$-2T+10$		ns
URTHnRXD hold time (to URTHnSC \uparrow)	t_{HRXDS1}	Input	10		$4T+10$		ns
URTHnTXD output delay time (to URTHnSC \downarrow)	t_{DTXDS1}	Output		30		30	ns
URTHnTXD output hold time (to URTHnSC \uparrow)	t_{HTXDS1}	Output	$t_{KWS1}-10$		$t_{KWS1}-10$		ns
URTHnCTS setup time (to URTHnTXD)	t_{SCTSS1}	Input	URTHnCTS without noise filter	$T+t_{KCYS1}+30$		$T+t_{KCYS1}+30$	ns
			URTHnCTS with noise filter	$3T+t_{KCYS1}+30$		$3T+t_{KCYS1}+30$	ns
URTHnRTS output delay time (to URTHnRXD)	t_{DRTSS1}	Output		$5T+30$		$T+30$	ns

Note n = 0, 1

T = Prescaler cycle time

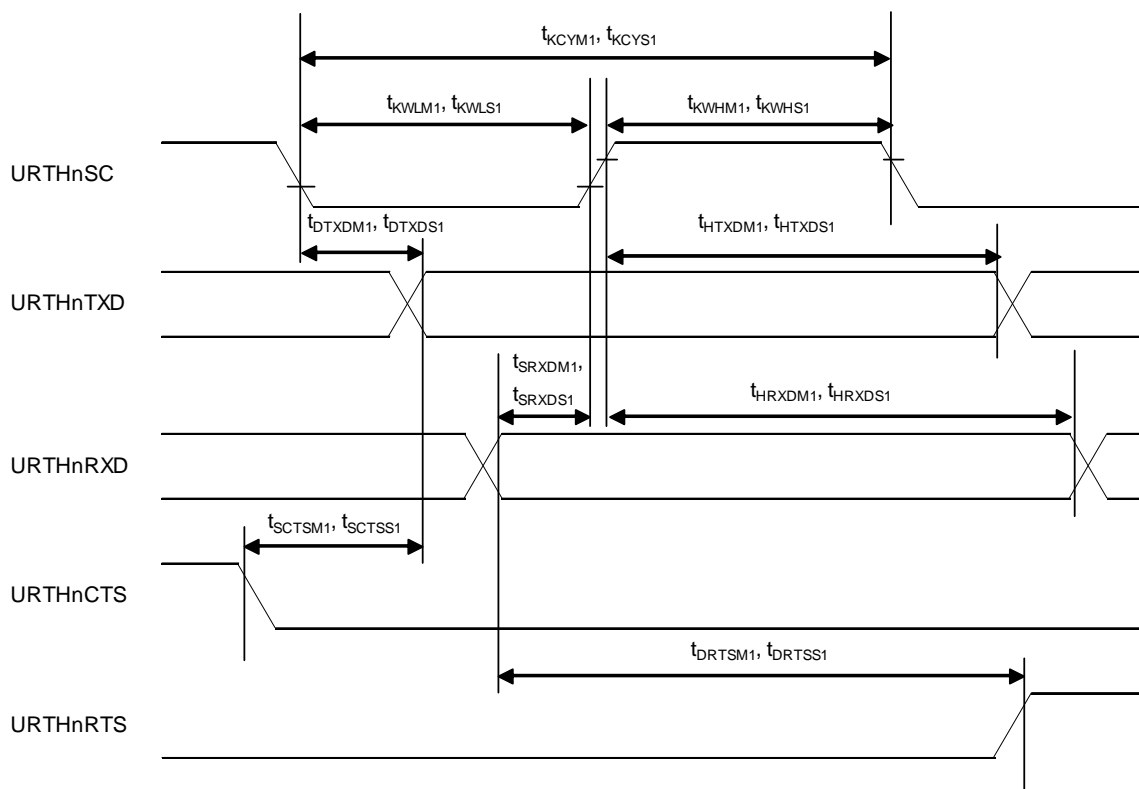

Note n = 0, 1

(d) Clock Synchronous, Master Mode (Delay Sampling Mode)

($T_a = -40$ to $+125^\circ\text{C}$, $V_{DD} = EV_{DD} = OSCV_{DD} = 3.0$ to 5.5 V,
 $AV_{DD0} = 4.2$ to 5.5 V, $V_{SS} = EV_{SS} = OSCV_{SS} = AV_{SS0} = 0$ V)

Item	Symbol	Conditions	URTHnRXD without Noise Filter		URTHnRXD with Noise Filter		Unit
			MIN.	MAX.	MIN.	MAX.	
URTHnSC cycle time	t_{KCYM2}	Output	500		500		ns
URTHnSC high level width	t_{KWHM2}	Output	$t_{KCYM2}/2 - 20$		$t_{KCYM2}/2 - 20$		ns
URTHnSC low level width	t_{KWLM2}	Output	$t_{KCYM2}/2 - 20$		$t_{KCYM2}/2 - 20$		ns
URTHnRXD setup time (to URTHnSC ↓)	t_{SRXDM2}	Input	$T + 30$		$3T + 30$		ns
URTHnRXD hold time (to URTHnSC ↓)	t_{HRXDM2}	Input	0		$-2T$		ns
URTHnTXD output delay time (to URTHnSC ↓)	t_{DTXDM2}	Output		10		10	ns
URTHnTXD output hold time (to URTHnSC ↑)	t_{HTXDM2}	Output	$t_{KCYM2}/2 - 10$		$t_{KCYM2}/2 - 10$		ns
URTHnCTS setup time (to URTHnTXD)	t_{SCTSM2}	Input	URTHnCTS without noise filter	$3T + 30$		$3T + 30$	ns
			URTHnCTS with noise filter	$5T + 30$		$5T + 30$	ns
URTHnRTS output delay time (to URTHnRXD)	t_{DRTSM2}	Output		$(BRS+1)T + 30$		$(BRS+1)T + 30$	ns

Note $n = 0, 1$

T = Prescaler cycle time

BRS: Setting of URTHnCTL2.URTHnBRS[11:0]

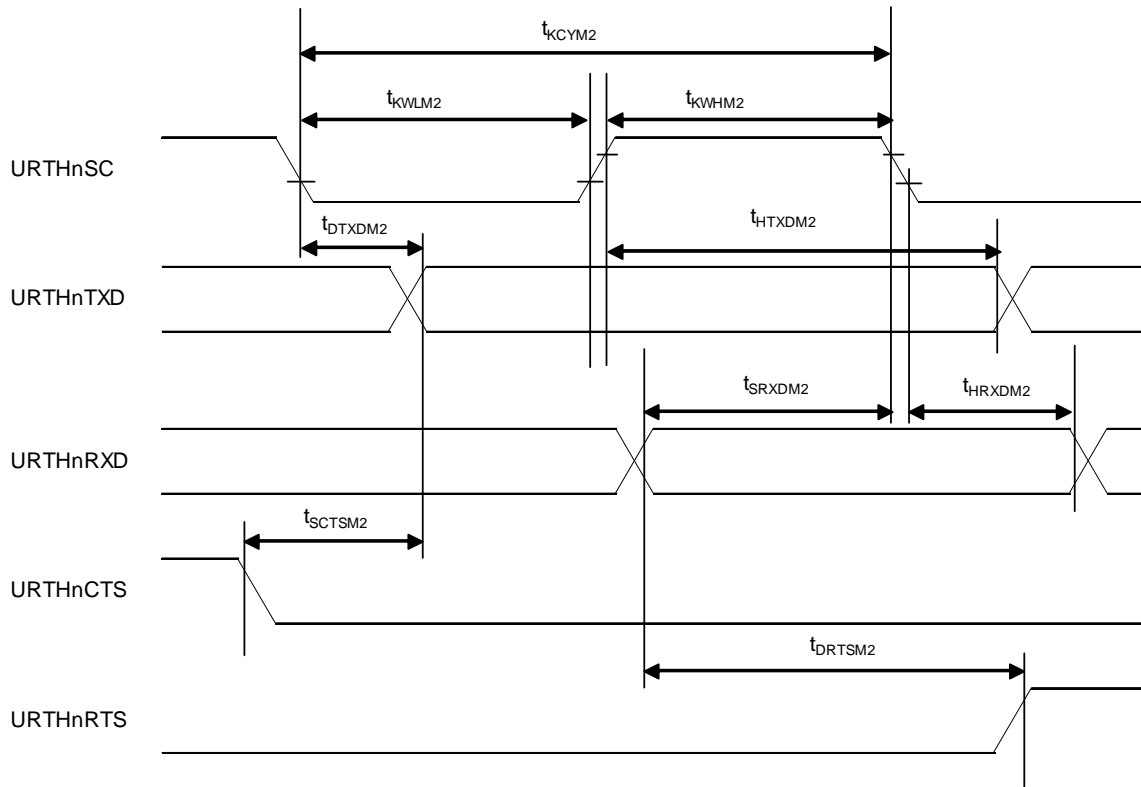

Note n = 0, 1

27.6.12 CAN Timing

($T_a = -40$ to $+125^\circ\text{C}$, $V_{DD} = EV_{DD} = OSCV_{DD} = 3.0$ to 5.5 V,
 $AV_{DD0} = 4.2$ to 5.5 V, $V_{SS} = EV_{SS} = OSCV_{SS} = AV_{SS0} = 0$ V)

Item	Symbol	Conditions	MIN.	MAX.	Unit
CAN transfer rate				1	Mbps
CAN internal delay time*1	t_{node}			87.5	ns

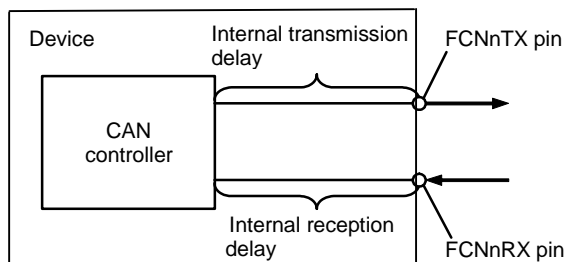
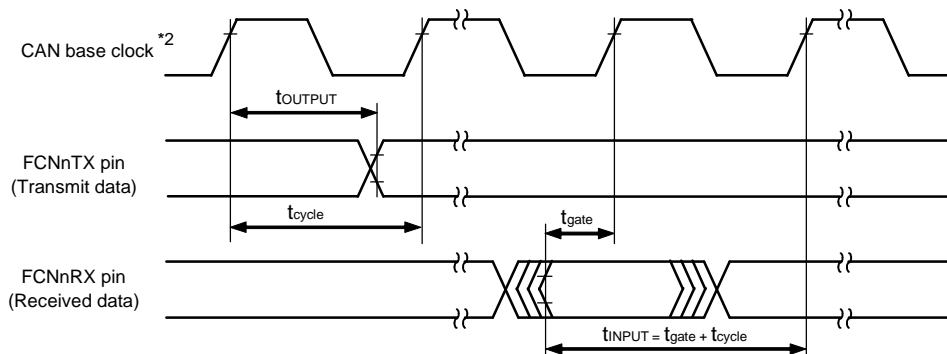

Schematic view of the CAN-internal delay

- Note 1. CAN-internal delay time (t_{node}) = internal transmission delay (t_{OUTPUT}) + internal reception delay (t_{INPUT})
- Note 2. CAN base clock frequency: f_{CAN}

Note n = 0, 1

27.6.13 Nexus Interface Timing

($T_a = 0$ to $+40^\circ\text{C}$, $V_{DD} = EV_{DD} = OSCV_{DD} = 3.0$ to 5.5 V,
 $AV_{DD0} = 4.2$ to 5.5 V, $V_{SS} = EV_{SS} = OSCV_{SS} = AV_{SS0} = 0$ V)

Item	Symbol	MIN.	MAX.	Unit
DCUTCK cycle time	t_{TCKW}	40.0		ns
DCUTDI setup time (to DCUTCK \uparrow)	t_{TDIS}	$t_{TCKW}/2 - 8.5$		ns
DCUTMS setup time (to DCUTCK \uparrow)	t_{TMSS}	$t_{TCKW}/2 - 8.5$		ns
DCUTDI hold time (to DCUTCK \uparrow)	t_{TDIH}	2.0		ns
DCUTMS hold time (to DCUTCK \uparrow)	t_{TMSH}	2.0		ns
DCUTDO output delay time (to DCUTCK \downarrow)	t_{TDOD}		20.0	ns
$\overline{\text{DCUTRDY}}$ output delay time (to DCUTCK \downarrow)	t_{RDYD}		20.0	ns
$\overline{\text{DCUTRST}}$ low level width	t_{TRSTWL}	1000		ns

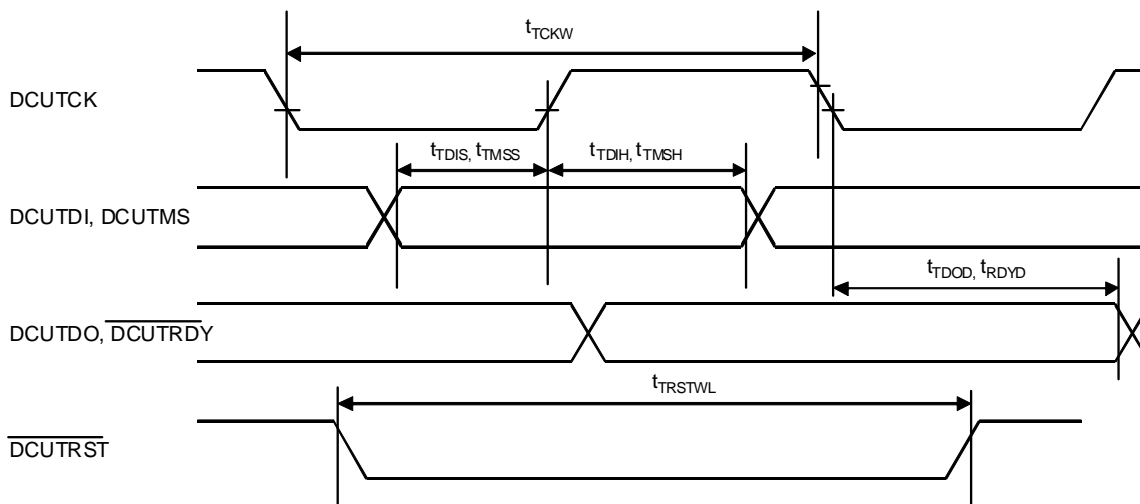

27.6.14 LPD Interface

($T_a = -40$ to $+125^\circ\text{C}$, $V_{DD} = EV_{DD} = OSCV_{DD} = 4.0$ to 5.5 V,
 $AV_{DD0} = 4.2$ to 5.5 V, $V_{SS} = EV_{SS} = OSCV_{SS} = AV_{SS0} = 0$ V)

Item	Symbol	Conditions	MIN.	MAX.	Unit
Transfer rate	t_{TCKW}	at 48-MHz operation		4	Mbps
		at 64-MHz operation		5.3	Mbps
		at 80-MHz operation		6.7	Mbps
Rise time	t_R	0.4 V→2.0 V transition time		3	ns
Fall time	t_F	2.0 V→0.4 V transition time		3	ns

27.6.15 A/D Converter Characteristics

(a) 10-Bit Resolution, without S/H

($T_a = -40$ to $+125^\circ\text{C}$, $V_{DD} = EV_{DD} = OSCV_{DD} = 3.0$ to 5.5 V, $4.2 \leq AV_{REF0P} = AV_{DD0} \leq 5.5$ V, $V_{SS} = EV_{SS} = OSCV_{SS} = AV_{REF0M} = AV_{SS0} = 0$ V)

Item	Symbol	Conditions	MIN.	TYP.	MAX.	Unit	
Resolution	RES				10	bit	
Power-down return time	t_{DPU}		10			ms	
Accuracy*1	TOE				± 2.0	LSB	
Conversion time	t_{CONV}		*2			μs	
Zero-scale error*1	ZSE				± 2.0	LSB	
Full-scale error*1	FSE				± 2.0	LSB	
Sampling time	t_{AS}		*2			clocks	
Analog input voltage	VIAN		AV_{REF0M}		AV_{REF0P}	V	
Differential non-linearity error*1	DNL				± 2.0	LSB	
Integral non-linearity error*1	INL				± 2.0	LSB	
AV_{REF0P} input current	A_{IREF1}			0.7	1.5	mA	
AV_{DD0} current	A_{IDD}	ADCA0GPS = 1, ADCA0BPC = 0, ADCA0DIAG = 0			8.7	mA	
		ADCA0GPS = 1, ADCA0BPC = 0, ADCA0DIAG = 1			9.7	mA	
		ADCA0GPS = 1, ADCA0BPC = 1, ADCA0DIAG = 0			9.0	mA	
		ADCA0GPS = 1, ADCA0BPC = 1, ADCA0DIAG = 1			10	mA	
	A_{IDDPD}	ADCA0GPS = 0		0.3	50	μA	
ANI pull-down resistor	R6		230	450	1900	k Ω	
Conversion result when using the self-diagnosis function		$AV_{REF0P} = AV_{DD0}$ $AV_{REF0M} = AV_{SS0}$ when self diagnosis is in use	AV_{DD0} conversion	1000		1023	LSB
			$2/3AV_{DD0}$ conversion	661	683	695	LSB
			$1/2AV_{DD0}$ conversion	497	512	522	LSB
			$1/3AV_{DD0}$ conversion	329	341	353	LSB
			AV_{SS0} conversion	0		25	LSB

Note 1. The accuracy, zero-scale error, full-scale error, differential non-linearity error, and integral non-linearity error do not include the quantization error.

Note 2. Depends on the settings of the related registers (see section 23, A/D Converter in the User's Manual).

(b) 10-Bit Resolution, with S/H

($T_a = -40$ to $+125^\circ\text{C}$, $V_{DD} = EV_{DD} = OSCV_{DD} = 3.0$ to 5.5 V, $4.2 \leq AV_{REF0P} = AV_{DD0} \leq 5.5$ V, $V_{SS} = EV_{SS} = OSCV_{SS} = AV_{REF0M} = AV_{SS0} = 0$ V)

Item	Symbol	Conditions	MIN.	TYP.	MAX.	Unit	
Resolution	RES				10	bit	
Power-down return time	t_{DPU}		10			ms	
Accuracy* ¹	TOE				± 2.5	LSB	
Conversion time	t_{CONV}			* ²		μs	
Channel S/H hold time	t_{CHOLD}				10	μs	
Zero-scale error* ¹	ZSE				± 2.5	LSB	
Full-scale error* ¹	FSE				± 3.0	LSB	
Sampling time	t_{AS}			* ²		clocks	
Channel S/H sampling time	t_{CAS}		0.4			μs	
Analog input voltage	VIAN		0.25		$AV_{REF0P} - 0.25$	V	
Differential non-linearity error* ¹	DNL				± 2.5	LSB	
Integral non-linearity error* ¹	INL				± 2.5	LSB	
AV_{REF0P} input current	A_{IREF1}			0.7	1.5	mA	
AV_{DD0} current	A_{IDD}	ADCA0GPS = 1, ADCA0BPC = 0, ADCA0DIAG = 0			12.7	mA	
		ADCA0GPS = 1, ADCA0BPC = 0, ADCA0DIAG = 1			13.7	mA	
		ADCA0GPS = 1, ADCA0BPC = 1, ADCA0DIAG = 0			13.0	mA	
		ADCA0GPS = 1, ADCA0BPC = 1, ADCA0DIAG = 1			14.0	mA	
	A_{IDDPD}	ADCA0GPS = 0		0.3	50	μA	
ANI pull-down resistor	R6		230	450	1900	k Ω	
Conversion result when using the self-diagnosis function		$AV_{REF0P} = AV_{DD0}$ $AV_{REF0M} = AV_{SS0}$ when self diagnosis is in use	AV_{DD0} conversion	1000		1023	LSB
			$2/3AV_{DD0}$ conversion	661	683	695	LSB
			$1/2AV_{DD0}$ conversion	497	512	522	LSB
			$1/3AV_{DD0}$ conversion	329	341	353	LSB
			AV_{SS0} conversion	0		25	LSB

Note 1. The accuracy, zero-scale error, full-scale error, differential non-linearity error, and integral non-linearity error do not include the quantization error.

Note 2. Depends on the settings of the related registers (see section 23, A/D Converter in the User's Manual).

(c) 12-Bit Resolution, without S/H

($T_a = -40$ to $+125^\circ\text{C}$, $V_{DD} = EV_{DD} = OSCV_{DD} = 3.0$ to 5.5 V, $4.2 \leq AV_{REF0P} = AV_{DD0} \leq 5.5$ V, $V_{SS} = EV_{SS} = OSCV_{SS} = AV_{REF0M} = AV_{SS0} = 0$ V)

Item	Symbol	Conditions	MIN.	TYP.	MAX.	Unit	
Resolution	RES				12	bit	
Power-down return time	t_{DPU}		10			ms	
Accuracy*1	TOE	$AV_{DD0} = 4.5$ to 5.5 V			± 6.0	LSB	
		$AV_{DD0} = 4.2$ to 5.5 V			± 7.0	LSB	
Conversion time	t_{CONV}		*2			μs	
Zero-scale error*1	ZSE	$AV_{DD0} = 4.5$ to 5.5 V			± 5.0	LSB	
		$AV_{DD0} = 4.2$ to 5.5 V			± 6.0	LSB	
Full-scale error*1	FSE	$AV_{DD0} = 4.5$ to 5.5 V			± 5.0	LSB	
		$AV_{DD0} = 4.2$ to 5.5 V			± 6.0	LSB	
Sampling time	t_{AS}		*2			clocks	
Analog input voltage	VIAN		AV_{REF0M}		AV_{REF0P}	V	
Differential non-linearity error*1	DNL	$AV_{DD0} = 4.5$ to 5.5 V			± 3.5	LSB	
		$AV_{DD0} = 4.2$ to 5.5 V			± 7.0	LSB	
Integral non-linearity error*1	INL	$AV_{DD0} = 4.5$ to 5.5 V			± 3.5	LSB	
		$AV_{DD0} = 4.2$ to 5.5 V			± 7.0	LSB	
AV_{REF0P} input current	A_{IREF1}			0.7	1.5	mA	
AV_{DD0} current	A_{IDD}	ADCA0GPS = 1, ADCA0BPC = 0, ADCA0DIAG = 0			8.7	mA	
		ADCA0GPS = 1, ADCA0BPC = 0, ADCA0DIAG = 1			9.7	mA	
		ADCA0GPS = 1, ADCA0BPC = 1, ADCA0DIAG = 0			9.0	mA	
		ADCA0GPS = 1, ADCA0BPC = 1, ADCA0DIAG = 1			10	mA	
	A_{IDDPD}	ADCA0GPS = 0		0.3	50	μA	
ANI pull-down resistor	R6		230	450	1200	k Ω	
Conversion result when using the self-diagnosis function		$AV_{REF0P} = AV_{DD0}$ $AV_{REF0M} = AV_{SS0}$ when self diagnosis is in use	AV_{DD0} conversion	4015		4095	LSB
			$2/3AV_{DD0}$ conversion	2631	2731	2771	LSB
			$1/2AV_{DD0}$ conversion	1968	2048	2088	LSB
			$1/3AV_{DD0}$ conversion	1305	1365	1405	LSB
			AV_{SS0} conversion	0		80	LSB

Note 1. The accuracy, zero-scale error, full-scale error, differential non-linearity error, and integral non-linearity error do not include the quantization error.

Note 2. Depends on the settings of the related registers (see section 23, A/D Converter in the User's Manual).

(d) 12-Bit Resolution, with S/H

($T_a = -40$ to $+125^\circ\text{C}$, $V_{DD} = EV_{DD} = OSCV_{DD} = 3.0$ to 5.5 V, $4.2 \leq AV_{REF0P} = AV_{DD0} \leq 5.5$ V, $V_{SS} = EV_{SS} = OSCV_{SS} = AV_{REF0M} = AV_{SS0} = 0$ V)

Item	Symbol	Conditions	MIN.	TYP.	MAX.	Unit	
Resolution	RES				12	bit	
Power-down return time	t_{DPU}		10			ms	
Accuracy*1	TOE	$AV_{DD0} = 4.5$ to 5.5 V			± 9.0	LSB	
		$AV_{DD0} = 4.2$ to 5.5 V			± 9.0	LSB	
Conversion time	t_{CONV}		*2			μs	
Channel S/H hold time	t_{CHOLD}				10	μs	
Zero-scale error*1	ZSE	$AV_{DD0} = 4.5$ to 5.5 V			± 8.0	LSB	
		$AV_{DD0} = 4.2$ to 5.5 V			± 9.0	LSB	
Full-scale error*1	FSE	$AV_{DD0} = 4.5$ to 5.5 V			± 8.0	LSB	
		$AV_{DD0} = 4.2$ to 5.5 V			± 9.0	LSB	
Sampling time	t_{AS}		*2			clocks	
Channel S/H sampling time	t_{CAS}		0.4			μs	
Analog input voltage	VIAN		0.25		$AV_{REF0P} - 0.25$	V	
Differential non-linearity error*1	DNL	$AV_{DD0} = 4.5$ to 5.5 V			± 5.0	LSB	
		$AV_{DD0} = 4.2$ to 5.5 V			± 6.0	LSB	
Integral non-linearity error*1	INL	$AV_{DD0} = 4.5$ to 5.5 V			± 5.0	LSB	
		$AV_{DD0} = 4.2$ to 5.5 V			± 6.0	LSB	
AV_{REF0P} input current	A_{REF1}			0.7	1.5	mA	
AV_{DD0} current	A_{IDD}	ADCA0GPS = 1, ADCA0BPC = 0, ADCA0DIAG = 0			12.7	mA	
		ADCA0GPS = 1, ADCA0BPC = 0, ADCA0DIAG = 1			13.7	mA	
		ADCA0GPS = 1, ADCA0BPC = 1, ADCA0DIAG = 0			13.0	mA	
		ADCA0GPS = 1, ADCA0BPC = 1, ADCA0DIAG = 1			14.0	mA	
	A_{IDDPD}	ADCA0GPS = 0		0.3	50	μA	
ANI pull-down resistor	R6		230	450	1200	k Ω	
Conversion result when using the self-diagnosis function		$AV_{REF0P} = AV_{DD0}$ $AV_{REF0M} = AV_{SS0}$ when self diagnosis is in use	AV_{DD0} conversion	4015		4095	LSB
			$2/3AV_{DD0}$ conversion	2631	2731	2771	LSB
			$1/2AV_{DD0}$ conversion	1968	2048	2088	LSB
			$1/3AV_{DD0}$ conversion	1305	1365	1405	LSB
			AV_{SS0} conversion	0		80	LSB

Note 1. The accuracy, zero-scale error, full-scale error, differential non-linearity error, and integral non-linearity error do not include the quantization error.

Note 2. Depends on the settings of the related registers (see section 23, A/D Converter in the User's Manual).

-
- Caution 1. Implement the following countermeasures to minimize any adverse effect on precision of the A/D converter from the switching noise of the digital circuit.
- i. Use one full side of the board for the power-supply wiring or connect the wiring in as large a grid pattern as possible.
 - ii. Insert a bypass capacitor in the vicinity of the pin lead between power supply pins (V_{DD} , EV_{DD} , $OSCV_{DD}$, or AV_{DD0}) and ground pin (V_{SS} , EV_{SS} , $OSCV_{SS}$, or AV_{SS0}), and between the analog reference voltage pins (AV_{REF0P} or AV_{REF0M}) and the analog ground pin (AV_{SS0}).
 - iii. We recommend isolating the analog power supply (AV_{DD0}) from the digital power supply (V_{DD} , EV_{DD} , or $OSCV_{DD}$) and supplying power via a series-connected regulator. When a common power supply is to be used, connect the analog power-supply line, digital power-supply line, and an electrolytic capacitor at a point in the source of the supply but wire the power supplies in isolation from each other on the board. Insert a chip inductor at the point of entry for the analog power supply voltage. In addition, earth the analog ground, digital ground, and an electrolytic capacitor at a point in the source of the power supply, but wire them in isolation from each other on the board.
- Caution 2. Connect resistor R_e and capacitor C_e to the analog input pin (ADCA0Im) externally to eliminate noise ($m = 01$ to 18).
- Caution 3. When the buffer amplifier is used or when the channel S/H is used, the signal source impedance should be equal to or less than 3 k Ω . In other cases, it should be equal to or less than 200 Ω .
-

Note Full-scale range (%FSR) is the ratio, as a percentage, of the extremes of the range of analog input voltages that can be converted, and is expressed as follows regardless of the resolution.

$$\begin{aligned}
 1\%FSR &= (\text{Maximum value of convertible analog input voltage} - \text{Minimum value of convertible analog input voltage})/100 \\
 &= (AV_{REF0P} - 0) / 100 \\
 &= AV_{REF0P} / 100
 \end{aligned}$$

1 LSB is as follows at a resolution of 10 bits:

$$\begin{aligned}
 1\text{LSB} &= 1/2^{10} \\
 &= 0.098\%FSR
 \end{aligned}$$

27.6.16 POF/LVI Characteristics

POF characteristics

($T_a = -40$ to $+125^\circ\text{C}$, $V_{DD} = EV_{DD} = OSCV_{DD} = 3.0$ to 5.5 V,
 $AV_{DD0} = 4.2$ to 5.5 V, $V_{SS} = EV_{SS} = OSCV_{SS} = AV_{SS0} = 0$ V)

Item	Symbol	Conditions	MIN.	TYP.	MAX.	Unit
Detected voltage	V_{POF}		2.65	2.8	2.9	V
Detection delay time	T_{d_pof}				2.0	ms
Minimum detection width	t_{POFW}	*1	0.2			ms
Voltage slope	P_{VS1}	At power on	0.18 V/ms		1.8 V/us	-
	P_{VS2}	In normal operation	1.8 V/s		1.8 V/us	-

Note 1. Time period when the V_{DD} voltage is equal to or less than the minimum value of the detected voltage.

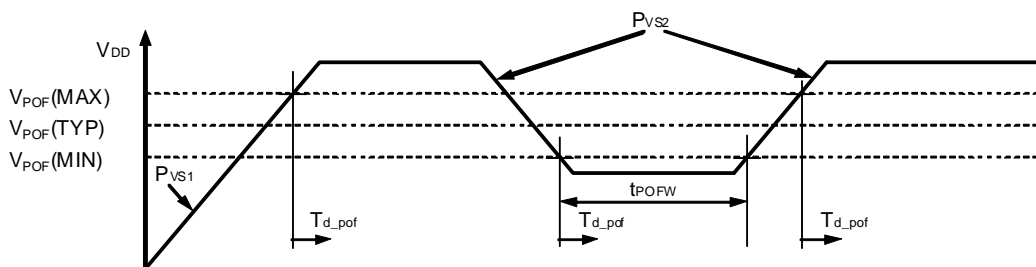

LVI characteristics

($T_a = -40$ to $+125^\circ\text{C}$, $V_{DD} = EV_{DD} = OSCV_{DD} = 3.0$ to 5.5 V,
 $AV_{DD0} = 4.2$ to 5.5 V, $V_{SS} = EV_{SS} = OSCV_{SS} = AV_{SS0} = 0$ V)

Item	Symbol	Conditions	MIN.	TYP.	MAX.	Unit
Detected voltage	V_{LVI0}	LVICNT.LVICNT[1:0] = 01 _B	4.5	4.6	4.7	V
	V_{LVI1}	LVICNT.LVICNT[1:0] = 10 _B	4.2	4.3	4.4	V
	V_{LVI2}	LVICNT.LVICNT[1:0] = 11 _B	3	3.1	3.2	V
Response time*1	t_{LD}	After EV_{DD} reaches V_{LVI0}, V_{LVI1} (MAX.) After EV_{DD} falls V_{LVI0}, V_{LVI1} (MIN.)			2	ms
Minimum detection width*2	t_{LW}		2			ms
Stabilization waiting time*3	T_{s_lvi1}				350	μs
Voltage slope	L_{VS}		1.8 V/s		1.8 V/us	μs

- Note 1. Time until output of an interrupt or reset after voltage detection.
- Note 2. Time where the VDD supply voltage is equal to or less than the minimum value of detected voltage.
- Note 3. Time until LVI is detected in accord with the specification after enabling of the LVI function.

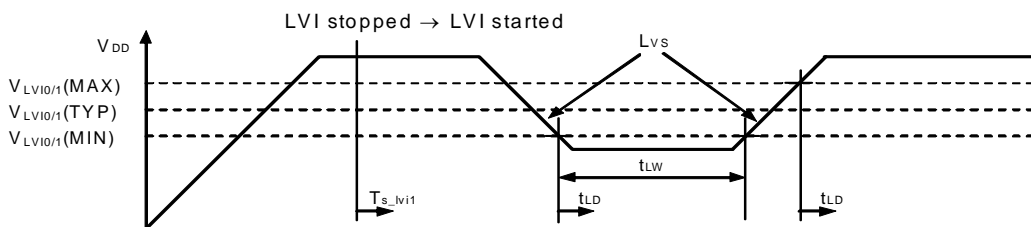

27.6.17 Flash Memory Programming Characteristics

(a) Basic Characteristics

($T_a = -40$ to $+125^\circ\text{C}$, $V_{DD} = EV_{DD} = OSCV_{DD} = 3.0$ to 5.5 V,
 $AV_{DD0} = 4.2$ to 5.5 V, $V_{SS} = EV_{SS} = OSCV_{SS} = AV_{SS0} = 0$ V)

Item	Symbol	Conditions		MIN.	TYP.	MAX.	Unit
Operating frequency	f_{CPU}					80	MHz
Number of times rewritable (per block)* ¹	C_{ERWR}	Code Flash	Data are retained for 20 years			1000	Times/block
		Data Flash	Data are retained for 20 years* ²			100000	Times/block

Note 1. In writing to a delivered product, either "erasing → writing" or "writing alone" is considered as a "time" of rewriting.

Example: (P: writing, E: erasing)

Delivered product → P → E → P → E → P: 3 times

Delivered product → E → P → E → P → E → P: 3 times

Note 2. Storage temperature: $T_a = T_j = 95^\circ\text{C}$

27.6.18 FLMD0 Pulse Timing Characteristics

($T_a = 0$ to $+40^\circ\text{C}$, $V_{DD} = EV_{DD} = OSCV_{DD} = 3.0$ to 5.5 V,
 $AV_{DD0} = 4.2$ to 5.5 V, $V_{SS} = EV_{SS} = OSCV_{SS} = AV_{SS0} = 0$ V)

Item	Symbol	Conditions	MIN.	TYP.	MAX.	Unit
FLMD0 setup time (to VDD)	t_{DP}		1			ms
$\overline{\text{RESET}}$ release (to FLMD0)	t_{PR}		$t_{OSC} + T_{d_pof} + 0.5 - t_{DP}$			ms
$\overline{\text{RESET}} \uparrow \rightarrow$ FLMD0 set time	t_{RP}		1			ms
FLMD0 pulse end time	t_{RPE}				11	ms
FLMD0 high/low level width	t_{PW}		10		100	μs
FLMD0 rise time	t_R				20	ns
FLMD0 fall time	t_F				20	ns
Serial clock input frequency	t_{SCCY}		9.8		5000	KHz
High level width	t_{WHSC}		85		50000	ns
Low level width	t_{WLSC}		85		50000	ns
FPDR setup time (to FPCK \uparrow)	t_{PLHSC}		75			ns
FPDR hold time (to FPCK \uparrow)	t_{PHLSC}		0			ns
FPDT output delay time	t_{DSC}				23	ns
UART transfer rate			9.6		1000	Kbps

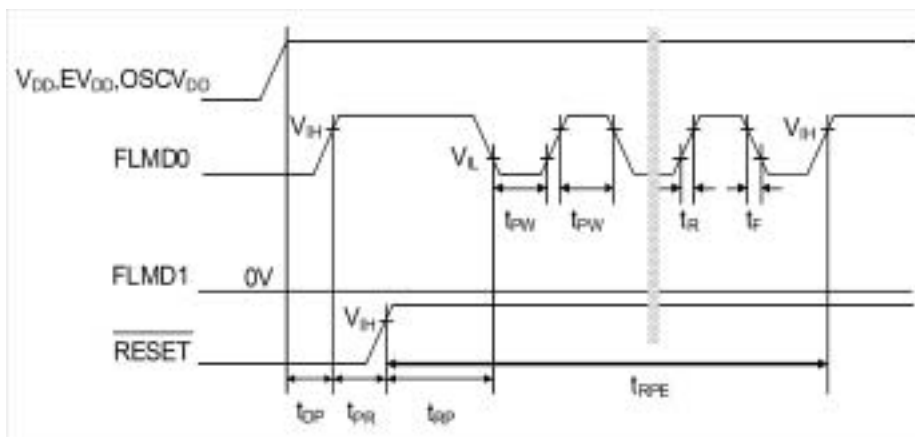

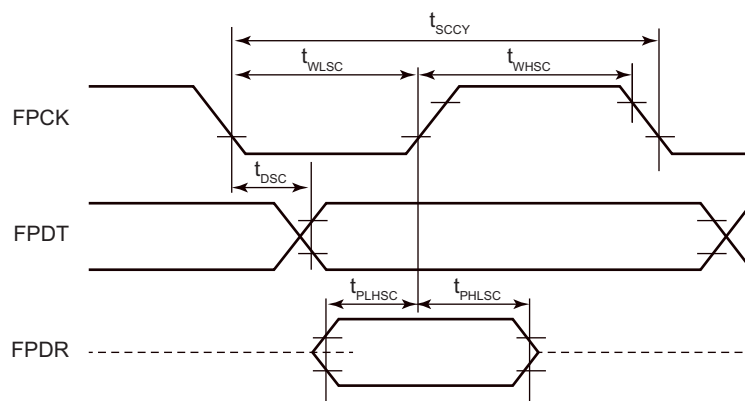

27.6.19 Self-Diagnosis BIST Execution Time

($T_a = -40$ to $+125^\circ\text{C}$, $V_{DD} = EV_{DD} = OSCV_{DD} = 3.0$ to 5.5 V,
 $AV_{DD0} = 4.2$ to 5.5 V, $V_{SS} = EV_{SS} = OSCV_{SS} = AV_{SS0} = 0$ V)

Item	Symbol	Condition 1	Condition 2	MIN.	TYP.	MAX.	Unit
Self-diagnosis BIST execution time		fx = 48 MHz				69	ms
		fx = 64 MHz				52	ms
		fx = 80 MHz				41	ms

REVISION HISTORY

V850E2/PG4-L User's Manual: Hardware

Rev.	Date	Description	
		Page	Summary
0.01	Mar 29, 2012	-	First edition issued
0.50	Sep 28, 2012	Throughout	Deletion of BSCAN related description
			Addition of JTAG related description
			Correction of names of units, signals (pins), registers and bits
			Changing JPwire to LPD (Single-pin debugging)
			Section 1 Introduction
		p.31	Correction of 1.7.1 Internal Block Diagram
		p.33	Separation of description of 1.7.2 (7) Timer Units
			Section 2 Port Functions
		p.42	Addition of 2.2.4 Port Control Logic Diagram
		p.59	Modification of Figure 2-1 Sequence for Writing to a Protected Port Register, and addition of step 5.
		p.67	Modification of Table 2-27 List of Pins Other than Port Pins (2/6)
		p.70-74	Addition of I/O circuit types to Table 2-28 Handling of Unused Port Pins, Table 2-29 Handling of Unused Pins Other than Port Pins and Figure 2-2 I/O circuit type
		p.77	Addition of pins and notes 4 and 5 to Table 2-31 List of States of Pins Other than Port Pins
		p.83	Addition of pins to Table 2-33 List of Pull-Up and Pull-Down Resistors for Pins Other than Port Pins (1/2)
			Section 3 CPU System Function
		p.115-116	Modification of Table 3-2 PPU Protected Areas and Modules
			Section 4 Interrupt Functions
		p.143	Modification of notes 1 and 2 for Table 4-2 List of Interrupt Sources
		p.144	Correction of address in 4.3 Interrupt Controller Control Registers
		p.167	Modification of description in 4.3.11 INTSTR0B: Error Interrupt Source Storage Register
		p.169	Correction of bit 1 name in table in 4.3.13 INTSTS0B
			Section 6 Memory Modules
		p.239	Modification of notes for 6.1.2 Data Flash Memory and 6.1.3 On-Chip RAM
		p.240	Correction of 6.3 (2) JPwire (single-pin debugging) communications
		p.241	Correction of description in 6.4.2 Pins
		p.243	Deletion of description and addition of caution in 6.5 Option-Setting Bytes
		p.244	Correction of description in Table 6-5 Option Byte Verification Register of V850E2/PG4-L Products
			Section 7 Clock Generation
		p.255	Changing of block name in 7.4 Clock Generating Circuit
		p.262	Modification of description in 7.6 Single-Pin Debugging Clock (LPDCLK)
		p.270	Modification of Table 7-16 Examples of CLMAnCMPH and CLMAnCMPL Register Settings
		p.272	Correction of access in 7.8.5 (1) CLMAnCTL0 - CLMAn Control Register 0
		p.273	Addition of caution to 7.8.5 (2) CLMAnCTL1 - CLMAn Control Register 1

REVISION HISTORY

V850E2/PG4-L User's Manual: Hardware

Rev.	Date	Description	
		Page	Summary
0.50	Sep 28, 2012	Section 8 Reset Controller	
		p.279	Modification of description in 8.1 (1) Internal Reset Signals
		p.292	Correction of accessing and addition of caution in 8.3.3 (1) SWRESA
		Section 9 Safety Functions	
		p.305	Modification of description in 9.3.2 (2) APES - Peripheral I/O Bus PSELG Error Status Register
		p.309	Modification of caution in 9.4 Overview of Self-Diagnostic BIST
		p.313	Correction of Table 9-10 Contents of the TGLOUTOE Register
		p.310	Modification of description in 9.4.2 Output of a Toggled Signal during Execution of Self-Diagnostic BIST
		p.335	Modification of description in 9.7 Self-Diagnosis Method for a Compare Unit
		Section 10 Safety Guardian (SGA)	
		p.348	Modification of description in 10.3.3 Operations for Error Output
		p.351	Deletion of description and figure in 10.3.6 Error Status
		pp.353-354	Deletion of registers in Table 10-8 Overview of SGA Master Registers and Table 10-9 Overview of SGA Checker Registers
		pp.357-358	Deletion of description in notes of 10.4.2 (3) SGAmESSTR0 and (4) SGAmESSTR1
		pp.360-361	Deletion of 10.4.2 (6) SGAmESSTR0n and (7) SGAmESSTR1n
		Section 12 Window Watchdog Timer A (WDTA)	
		p.390	Correction of description of WDTA trigger in 12.4.2 (1) WDTA Enable Register
		Section 13 Timer Array Unit B (TAUB)	
		p.392	Correction of Table 13-2 Register Base Address <TAUBn_base>
		p.590	Correction of description in 13.21.2 (1) TAUBnTPS
		p.594	Correction of address in 13.21.3 (1) TAUBnCDRm
		p.603-604,612	Correction of description in Tables 13-129, 13-130, 13-132 and 13-144
		Section 14 Timer Array Unit J (TAUJ)	
		p.626	Correction of Figure 14-4 General Procedure for Simultaneous Rewrite
		p.627	Deletion of description in 14.7.2 (1) Initial settings
		p.652	Deletion of description of Functional description in 14.12.3 (1) Overview
		p.652, 661	Modification of Table 14-20 and Table 14-25 Effects of Overflow
		p.657, 665, 672	Modification of description in Table 14-24 Operating Procedure for TAUJnTTINm Input Pulse Interval Measurement Function, Table 14-29 Operating Procedure for TAUJnTTINm Input Signal Width Measurement Function and Table 14-33 Operating Procedure for TAUJnTTINm Input Period Count Detection Function
		p.669, 674	Correction of formula in 14.12.5 and 14.12.6 (2) Equations
		pp.696-697	Correction of access in 14.14.3 (1) TAUJnCDRm and (2) TAUJnCNTm
		Section 18 Encoder Timer (ENCA)	
		pp.1006-1007	Deletion of description in 18.6 (4) Timing of Basic Encoder Operation 4 (Encoder Capture Mode) and (5) Timing of Basic Encoder Operation 5 (Encoder Capture and Comparison Mode)

REVISION HISTORY

V850E2/PG4-L User's Manual: Hardware

Rev.	Date	Description	
		Page	Summary
0.50	Sep 28, 2012	Section 19 Timer Option Module (TAPA)	
		p.1022	Correction of Initial value in 19.3.2 (3) TAPAnFLG - TAPAn Flag Register
		pp.1033-1035, 1037	Correction of description in 19.4.3 Selection of INT Signal Output and 19.4.4 Selecting a Trigger to Start Conversion by the A/D Converter
		Section 20 CAN Controller (FCN)	
		p.1098	Modification of Figure 20-6 Reception Timing
		p.1101	Correction of 20.7.4 (3) FCN Module 1 Mask Setting (Mask 1)(Example)
		p.1132	Correction of Figure 20-13 Initialization
		Section 21 Clocked Serial Interface G (CSIG)	
		p.1172	Correction of Note 5 for Figure 21-7 EDL Timing Diagram
		p.1186	Addition of CSIGnMBS Bit to 21.4 (1) CSIGnCTL0 - CSIG Control Register 0
		Section 22 Synchronous/Asynchronous Serial Interface H (URTH)	
		pp.1215-1216	Modification of description in Initial value of 22.4 (5) URTHnSTR0 and (6) URTHnSTR1
		pp.1216-1217	Modification of description in Table 22-12 URTHnSTR1 Register Contents
		p.1224	Modification of description in 22.4 (11) URTHnRX
		p.1228	Addition of Table 22-21 Accesses according to Reception Modes
		p.1229	Addition of description to 22.4 (15) URTHnTX
		p.1231	Modification of description in Table 22-24 URTHnETX Register Contents
		p.1233	Addition of Table 22-26 Accesses according to Transmission Modes
		p.1234	Modification of description in Table 22-27 IC0REG0 Register Contents
		Section 23 A/D Converter	
		p.1267	Addition of Figure 23-1 ADCAn Block Diagram
		p.1270	Modification of description in 23.3.1 Basic Operation
		p.1279	Addition of caution to 23.3.6 Stopping A/D Conversion (Stop Trigger)
		p.1280	Addition of note to Table 23-3 Total Conversion Time
		p.1290	Addition of Figure 23-14 Outline of Self-Diagnosis Functions
		p.1294	Addition of figure and caution, and deletion of description in 23.3.12 Channel Sample and Hold Function
		p.1300	Addition of caution to 23.3.14 Buffer Amplifier Function
		p.1301	Correction of Table 23-6 List of ADCAn Registers (1/2)
		p.1304	Modification of description of bit 7 in Table 23-7 ADCAnCTL0 Register Contents (2/2)
		p.1309	Modification of description in Table 23-11 ADCAnCNT Register Contents
		pp.1311-1312	Addition of 23.4.2 (7) ADCAnSMCNT to (10) ADCAnDISCNT
		p.1319	Addition of notes to Table 23-22 ADCAnLCR Register Contents
		p.1321	Correction of note in Table 23-23 ADCAnLCR Register Contents
Section 24 Peripheral Interconnection (PIC)			
Throughout	Deletion of 3-phase pulse input control function		
p.1348	Correction of Table 24-3 Registers for Various Functions		

REVISION HISTORY

V850E2/PG4-L User's Manual: Hardware

Rev.	Date	Description	
		Page	Summary
0.50	Sep 28, 2012	p.1393	Deletion of registers in table Registers related to TAUB0 channels in common (cont.)
		p.1406	Deletion of registers in Figure 24-20 Setting Flow (cont.) (m = 0 to 2)
		p.1410	Deletion of bits in Table 24-26 PIC Setting
		p. 1413, 1415-1416	Correction of Table 24-28 PIC0ENCSEL400 Contents, 24.4.5.5 Operation Flow and 24.4.5.6 Register Setting Examples for Various Functions
		p.1462	Deletion of register in Table 24-52 TAUB0 Setting
		Section 25 On-chip Debugging Unit (OCD)	
		p.1470	Addition and modification of description in 25.1 (9) Measuring Times, (10) Masking and (12) Hot Plug-in
		p.1474	Addition of figure to 25.2 (2) LPD I/F (Single-pin debugging interface)
		p.1477	Addition of description to 25.3 (2) Using the Single-Pin Debugging Interface
		Section 26 Power Supply Configuration	
		p.1478	Addition of pin numbers to Table 26-1 List of Pins Used for the Power Supply
		Section 27 Electrical Specification (Target)	
		Throughout	Added on this edition
		1.00	Mar 29, 2013
pp.25-26	Correction of 1.3 List of Functions		
p.34	Correction of 1.7.1 Internal Block Diagram		
Section 2 Port Functions			
p.62	Modification of steps 2 to 4 in (4) Sequence for Writing to a Protected Port Register		
p.74	Correction of FLMD0 pin handling		
p.79	Deletion of JP0_0		
p.108	Addition of DNFA _n ENL to Table 2-53 The List of Registers for the Digital Noise Canceller		
p.111	Deletion of description in 2.14.2 (2) DNFA _n EN - Access		
Section 3 CPU System Function			
p.116	Deletion of FPU in Table 3-1 Descriptions of CPU Functions		
p.117	Deletion of Caution in 3.1 Overview - CPU		
p.122	Modification of 3.1.2 Important Reminders		
p.123	Modification of Note in 3.2 Operation Modes		
Section 4 Interrupt Functions			
p.146	Modification and addition of Notes		
Section 5 DMA Module			
p.190	Modification of title Instances index n, m and l in 5.1 DMA in Overview		
p.220, 221	Correction of register names - address in 5.5.15 DTC _n and 5.5.16 DNTC _n		
Section 6 Memory Modules			
p.241, 242	Addition of Notes to Table 6-2 and Table 6-3		
p.247	Modification of bit 23 in Table 6-5 Option Byte of V850E2/PG4-L Products		
p.248	Addition of description to (1) PRDNAME Register		

REVISION HISTORY

V850E2/PG4-L User's Manual: Hardware

Rev.	Date	Description	
		Page	Summary
1.00	Mar 29, 2013	Section 7 Clock Generation	
		p.268	Addition of Caution to 7.8.3 Functional Overview
		p.273	Modification of Table 7-16 Examples of CLMAnCMPH and CLMAnCMPL Register Settings
		Section 8 Reset Controller	
		p.282	Modification of (2) Timing of De-Assertion of the External Reset Signal after the Power Supply is Turned on
		p.293	Addition of Note to 8.3.2 (1) RESF
		p.296	Addition of Note to 8.3.3 (1) SWRESA
		p.299	Modification of Caution in 8.4.2 (1) POF Detection
		p.304	Correction of address in 8.4.4 (3) POFS
		Section 9 Safety Functions	
		p.317	Modification of bit 5 in Table 9-10 Contents of the TGLOUTOE Register
		p.320	Addition of Note to 9.5.2 (3) BSEQ0CTLx
		p.340	Addition of Caution to 9.8.1 On-chip RAM
		Section 10 Safety Guardian (SGA)	
		p.361	Modification of Caution in 10.4.2 (4) SGAmESSTR1
		Section 13 Timer Array Unit B (TAUB)	
		Throughout	Correction of TAUBnCMURm register figures Correction of signal names
		p.427	Modification of Note in 13.10 TAUBnTTOUTm Output and INTTAUBnIm Generation when Counter Starts or Restarts
		p.429	Addition of Caution to 13.11 TAUBnTTINm Edge Detection
		-	Deletion of a figure Forced Restart Operation
		p.455, 462, 469, 507	Modification of initial channel settings in Table 13-31, Table 13-36, Table 13-40 and Table 13-66
		p.457	Correction of Figure 13-33 TAUBnCMORm.TAUBnCOS[1:0] = 11 _B , TAUBnCMORm.TAUBnMD0 = 0, TAUBnCMURm.TAUBnTIS[1:0] = 00 _B
		p.466	Correction of 13.14.3 (2) Equations
		p.471	Modification of description in 13.14.4 (1) Overview
		p.476	Modification of description in 13.14.5 (1) Overview
		p.501, 502	Correction of Figure 13-57 and Figure 13-58
		p.503	Correction of 13.16.3 (2) Equations
		p.515	Modification of Note in 13.18.1 (4) (d) Simultaneous rewrite for master channels
		p.517	Correction of title Table 13-72 Control Bit Settings in Synchronous Channel Output Mode 1
		p.523	Modification of Note 2 in Equations in 13.18.2 (1) Overview
		p.538	Correction of Figure 13-71 Block Diagram of AD Conversion Trigger Output Function Type 1
		p.541	Modification of Prerequisites in 13.19.1 (1) Overview

REVISION HISTORY

V850E2/PG4-L User's Manual: Hardware

Rev.	Date	Description	
		Page	Summary
1.00	Mar 29, 2013	p.548	Correction of title Table 13-95 Control Bit Settings in Independent Channel Output Mode 2
		p.549	Modification of During Operation in Table 13-97 Operating Procedure for One-Shot Pulse Output Function
		p.556	Addition of unit to 13.20.1 (2) Equations
		p.564, 565	Modification of description in 13.20.1 (7) Specific timing diagrams
		p.568	Modification of 13.20.2 (2) Equations
		pp.579-581	Modification of titles and descriptions of Figure 13-85 and Figure 13-86
		p.592	Correction of register group name in Table 13-121 Overview of TAUBn Registers
		p.602	Correction of register name in Table 13-126 Description of TAUBnCMORm Register (3/4)
		p.610	Addition of description to Access in 13.21.4 (4) TAUBnTDE
		p.615	Correction of flag name in Table 13-144 Description of TAUBnRDT Register
		p.616	Modification of Address and Table 13-145 in 13.21.6 (6) TAUBnRSF
		p.618	Deletion of TAUJ0TTIN1, 3 in Table 14-5 TAUJn I/O Signals
		Section 14 Timer Array Unit J (TAUJ)	
		p.655	Correction of Figure 14-20 Counter Triggered by Rising TAUJnTTINm Input Edge
		p.690	Correction of title Table 14-43 Control Bit Settings in Synchronous Channel Output Mode 1
		Section 15 TSG2 (TSG20)	
		p.735	Correction of bit 4 in Table 15-14 TSnIOC1 Register Contents (1/2)
		p.777	Correction of register names in Table 15-40 Active Width Setting in SP-PWM Mode
		p.788	Correction of INTTSG2nI11 in Table 15-44 List of Interrupts in Each Mode (3/5)
		p.896	Correction of signal names in Figure 15-79 and Figure 15-80
		Section 16 TPBA	
		p.907	Correction of item name in Table 16-1 Instances of TPBA
		p.935	Correction of Figure 16-5 Example of Basic Timing (2/2) and the Note 2
		Section 18 Encoder Timer (ENCA)	
		p.963	Correction of connection in Table 18-5 List of ENCA _n Input Signals
		p.1010, 1011	Modification of Setting condition and correction of register name in 18.6 (5) Timing of Basic Encoder Operation 5
		Section 19 Timer Option Module (TAPA)	
		Throughout	Correction of signal names
		p.1012	Correction of Instances index n in 19.1 Features of the Timer Option Module
		p.1016	Figure 19-1 Hi-Z Control Signals for TAPA0 and TAPA2
		p.1017, 1018	Correction of Addresses in 19.1 (1) Hi-Z Output Control Register 0 and (2) Hi-Z Output Control Register 2
		p.1023	Modification of 19.3.2 (1) TAPAnCTL0
		p.1030	Modification of 19.4.2 (1) An Example of System Configuration of Asynchronous Hi-Z Control for Pin Inputs

REVISION HISTORY

V850E2/PG4-L User's Manual: Hardware

Rev.	Date	Description			
		Page	Summary		
1.00	Mar 29, 2013	p.1031	Correction of title 19.4.2 (2) (a) Hi-Z Control when TAPAnCTL0.TAPAnDCM = 0, TAPAnDCP = 1, and TAPAnDCN = 0		
		p.1036	Correction of Address in 19.4.3 (1) Configuration of INT Signal Output Selection		
		p.1043	Deletion of a figure (no title)		
		Section 20 CAN Controller (FCN)			
		throughout	Correction of FCN transmission/reception pin names as FCNnTX/FCNnRX		
		p.1061	Correction of bit name in second Note 1		
		p.1064	Correction of bit name in Note		
		p.1067	Addition of description and Modification of 20.5.1 (5) FCNnDNBMRXk		
		pp.1068-1069	Modification of 20.5.2 (1) FCNnCMMKCTLaH		
		pp.1071	Modification of 20.5.2 (2) (a) FCNnCMCLCTL Read		
		p.1075	Modification of FCNnCMINSSTE in 20.5.2 (4) FCNnCMINSTR		
		p.1083	Modification of FCNnCMRGRVFF in 20.5.2 (11) (a) FCNnCMRGRX Read		
		p.1085	Modification of FCNnCMTGTVFF in 20.5.2 (13) (a) FCNnCMTGTX Read		
		p.1088	Modification of 20.5.3 (1) FCNnMmDATxB/H/W		
		p.1089, 1090	Addition of description to Initial value in 20.5.3 (2) FCNnMmDTLGB and (3) FCNnMmSTRB		
		p.1091, 1092	Correction of 20.5.3 (4) FCNnMmMID0H, FCNnMmMID1H, FCNnMmMID0W		
		pp.1093-1094	Modification of 20.5.3 (5) (a) FCNnMmCTL Read		
		p.1097	Deletion of description in 20.6.2 (3) Redefining Message Buffer during Transmission		
		p.1098	Modification of Figure 20-4 Setting Transmission Request to Transmit Message Buffer after Redefinition		
		p.1101	Modification of Figure 20-6 Reception Timing		
		pp.1102-1103	Modification of 20.7.3 Receive History List Function		
		p.1104	Modification of 20.7.4 Mask Function		
		p.1111	Modification of Note 1 in Figure 20-9 Transmit History List		
		p.1112	Modification of 20.8.3 Automatic Block Transmission (ABT)		
		p.1114	Modification of 20.8.4 Transmission Abort Process		
		p.1122	Modification of 20.11.1 Receive-only Mode		
		p.1135, 1137	Modification of Figure 20-13 and Figure 20-15		
		p.1039	Modification of Figure 20-17 Message Buffer Redefinition during Reception		
		p.1142	Modification of Caution for Figure 20-20 ABT Message Transmit Processing		
		pp.1148-1149	Modification and addition of Note to Figure 20-25		
		p.1149, 1150	Modification of Figure 20-26 ABT Transmission Request Abort Processing (Normal Operating Mode with ABT) (1) and the Caution 2		
		p.1151	Addition of Figure 20-27 ABT Transmission Request Abort Processing (Normal Operating Mode with ABT) (2)		
		p.1152-1153	Modification of Figure 20-28 ABT Transmission Request Abort Processing (Normal Operating Mode with ABT) with Transmit Completion Interrupt Flag		

REVISION HISTORY

V850E2/PG4-L User's Manual: Hardware

Rev.	Date	Description	
		Page	Summary
1.00	Mar 29, 2013	p.1154	Deletion of Caution and Note for Figure 20-29 Transmission Abort Processing with Transmission Abort Interrupt and Transmission Completion Flag
		p.1155	Deletion of Note for Figure 20-30 Transmission Abort Processing with Transmission Completion Flag
		Section 21 Clocked Serial Interface G (CSIG)	
		p.1169	Addition of Table 21-6 Port Groups for CSIGn
		p.1174	Modification of 21.3.3 Selection of Serial Communications Clock
		Section 22 Synchronous/Asynchronous Serial Interface H (UARTH)	
		p.1208	Addition of Table 22-6 Port Groups for UARTHn
		p.1231	Modification of Table 22-20 UARTHnERX Register Contents
		p.1238	Correction of signal names in Table 22-28 IC0REG0 Register Contents
		Section 23 A/D Converter	
		pp.1284-1285	Modification of 23.3.7 Resolution, Sampling Time and Conversion Time
		p.1295-1296	Addition of description and modification of figure in 23.3.11 (3) Diagnosis of Analog Input Pins
		p.1297, 1298	Modification of 23.3.11 (4) Diagnosis of Channel Sample and Hold Circuit
		p.1303	Modification of Example 6
		p.1305	Modification of Note in 23.3.13 Discharge Function
		p.1307	Correction of register name in Table 23-6 List of ADCAn Registers (1/2)
		p.1312	Correction of bits 9 to 8 in Table 23-8 ADCAnCTL1 Register Contents (2/2)
		p.1325	Deletion of Note for Table 23-22 ADCAnLCR Register Contents
		p.1329	Addition of Note 1 for Table 23-24 ADCAnDBiCR Register Contents
		p.1330	Correction of Note 2 for Table 23-25 ADCAnDBiCRL Register Contents
		p.1341	Correction of pin names in 23.5.4 (2) (b), (c)
		p.1342	Modification of Note in Figure 23-17 Example of Measures against Noise on Analog Input Circuit
		p.1343	Modification of table for Figure 23-18 Internal Equivalent Circuit of ADCAnIm Pin
		Section 24 Peripheral Interconnection (PIC)	
		Throughout	Correction of signal names
		p.1353	Deletion of PIC0SSER1 register in Table 24-2 PIC Registers
		p.1355	Correction of address in 24.3.1 (1) Control Register EN
		p.1371	Correction of CH in Function Name in a table of 24.4.3.2 Configuration
		p.1393	Correction of setting value of TAUBnCDRm register in Figure 24-14 Setting Flow
		p.1394	Correction of setting value of TAUB0TT register in Figure 24-15 Setting Flow
		pp.1411-1412	Correction of setting value in Figure 24-19, Figure 24-20 Setting Flow
		p.1414, 1415	Correction of setting values in Table 24-24 TAUJ0 Setting and Table 24-25 TAUB0 Setting
		p.1417	Correction of signal name in bit 4 to 2 in Table 24-27 PIC0REG30 Contents
		p.1423	Correction of setting values to TAPA2 in Figure 24-24 Block Diagram of Timer Configuration 1

REVISION HISTORY

V850E2/PG4-L User's Manual: Hardware

Rev.	Date	Description			
		Page	Summary		
1.00	Mar 29, 2013	p.1430	Correction of setting values in Figure 24-27 Initial Setting and Operation Start Flow		
		p.1432	Correction of setting value of ENCA0LDE bit in Table 24-34 ENCA0 Setting		
		p.1433, 1434	Correction of setting values of TS0IOC0 register and deletion of TS0CMP1, 5, 9 registers in Table 24-35 TSG20 Setting		
		p.1435	Correction of setting values to TAPA2 in Figure 24-30 Block Diagram of Timer Configuration 1		
		p.1441	Correction of setting values in Figure 24-34 Initial Setting and Operation Start Flow		
		p.1443	Correction of setting value of ENCA0LDE bit in Table 24-40 ENCA0 Setting		
		p.1444, 1445	Correction of setting values of TS0IOC0 register and deletion of TS0CMP1, 5, 9 registers in Table 24-41 TSG20 Setting		
		p.1446	Correction of register name in Figure 24-38 Block Diagram of Timer Configuration 1		
		p.1451	Correction of setting values in Figure 24-41 Initial Setting and Operation Start Flow		
		p.1452	Correction of setting values in Table 24-45 ENCA0 Setting		
		p.1453	Correction of setting value of TS0CTL0 register in Table 24-46 TSG20 Setting		
		Section 25 On-chip Debugging Unit (OCD)			
		p.1479	Correction of 25.2 (2) LPD I/F		
		p.1480-1483	Addition and correction of description to 25.3 Notes on On-Chip Debugging		
		Section 27 Electrical Specification			
		Throughout	Correction of value of AV _{DD0}		
		p.1485	Modification of 27.1 Absolute Maximum Ratings		
		pp.1489-1491	Modification of 27.5 DC Characteristics		
		p.1496	Correction of pin name in timing chart		
		p.1497	Modification of 27.6.4 Regulator Characteristics		
		p.1502	Modification of conditions in 27.6.9 Timer Timing		
		p.1503,1504,1506,1507	Modification of 27.6.10 CSIGN Timing		
		p.1518	Specification of 27.6.14 LPD Interface		
		pp.1519-1523	Specification of 27.6.15 A/D Converter Characteristics		
		p.1524, 1525	Specification of 27.6.16 POF/LVI Characteristics		
		p.1527	Modification of t _{PR} value in 27.6.18 FLMD0 Pulse Timing Characteristics		
		p.1528	Modification of 27.6.19 Self-Diagnosis BIST Execution Time		
		1.01	Jun 25, 2014	Section 1 Introduction	
				28, 29, 32, 33	1.6 Pin Connection Diagram (Top View), changed pin names
				Section 2 Port Functions	
65	Table 2-26 List of Port Groups (2/2), added Note 1				
70, 71	Table 2-27 List of Pins Other than Port Pins (5/6), (6/6), added Note 1				
74	Table 2-28 Handling of Unused Port Pins (3/3), added Note 1				
75, 76	Table 2-29 Handling of Unused Pins Other than Port Pins, added Note 1				
78	Figure 2-2 I/O circuit type(2/2), corrected				
80	Table 2-30 List of States of Port Pins(2/2), added Note 1				

REVISION HISTORY

V850E2/PG4-L User's Manual: Hardware

Rev.	Date	Description	
		Page	Summary
1.01	Jun 25, 2014	81	Table 2-31 List of States of Pins Other than Port Pins(2/2), added Note 6
		90	Table 2-35 List of Port 0 Control Registers, corrected PIPC0
		94	Table 2-39 List of Port 2 Control Registers, corrected PFCE2
		114	2.14.2 (3) Digital Noise Canceller Enable Register L
		115	Table 2-58 DNFCTL Register Contents, changed
			Section 3 CPU System Function
		120, 122, 123	Table 3-2 PPU Protected Areas and Modules (1/4), (3/4), (4/4), added and deleted descriptions
			Section 4 Interrupt Functions
		141,145,147	Table 4-2 List of Interrupt Sources (1/8), (5/8), (7/8), added Notes
		172	4.3.11 INTSTR0B, corrected register name in the description
			Section 6 Memory Modules
		248	6.5 Option-Setting Bytes, corrected Caution
			Section 7 Clock Generation
		275	Table 7-16 Examples of CLMAnCMPH and CLMAnCMPL Register Settings, added Note 1
			Section 8 Reset Controller
		286	8.2.2 Low-Voltage Indicator (LVI) - LVI reference voltage, changed
		287	8.2.3 External RESET, changed
		306	8.4.4 (4) LVICNT, changed the description
			Section 13 Timer Array Unit B (TAUB)
		410	Table 13-8 Simultaneous Rewrite Methods and Trigger Timing, corrected
		411	Table 13-9 Simultaneous Rewrite and Trigger Timing, added Note
		417	13.7.4 (2) Simultaneous rewrite at the peak of a triangular cycle of master channel (method B), and Figure 13-6 Simultaneous Rewrite at the Peak of a Triangular Cycle of Master Channel, corrected the titles
		419	Figure 13-7 Simultaneous Rewrite When INTTAUBnIm Is Generated on an Upper Channel Specified by TAUBnRDC.TAUBnRDCm, corrected
		420	13.7.4 (3) Simultaneous rewrite when INTTAUBnIm is generated on an upper channel specified by TAUBnRDC.TAUBnRDCm (method C1), changed Description 5
		429	Table 13-11 Effect of CMOR.TAUBnMD0 Bit on Generation of INTTAUBnIm when Counter Is Triggered, corrected
		446	13.13.3 (1) Overview - Prerequisites, corrected
		452	Table 13-27 Effects of Overflow, corrected 13.14.1 (1) Overview - Description, deleted description
		453	13.14.1 (1) Overview - Conditions, corrected Note
		460	Table 13-32 Effects or Overflow, corrected
		468	13.14.3 (1) Overview - Description, deleted description, and (2) Equations, corrected
		469	Figure 13-40 Block Diagram of TAUBnTTINm Input Period Count Detection Function, corrected
		469	Figure 13-41 General Timing Diagram of TAUBnTTINm Input Period Count Detection Function, corrected

REVISION HISTORY

V850E2/PG4-L User's Manual: Hardware

Rev.	Date	Description			
		Page	Summary		
1.01	Jun 25, 2014	470	Table 13-37 TAUBnCMORm Settings for TAUBnTTINm Input Period Count Detection Function, corrected		
		471	Table 13-40 Operating Procedure for TAUBnTTINm Input Period Count Detection Function, corrected		
		472	Figure 13-42 Operation Stop and Restart (TAUBnCMURm.TAUBnTIS[1:0] = 11 _B), corrected		
		486	Figure 13-48 Block Diagram of Simultaneous Rewrite Trigger Generation Function Type 1, corrected and added description		
		505	13.16.3 (1) Overview - Description, deleted description, and (2) Equations, corrected		
		506	Figure 13-60 General Timing Diagram for TAUBnTTINm Input Position Detection Function, corrected		
		507	Table 13-63 TAUBnCMORm Settings for TAUBnTTINm Input Position Detection Function, corrected		
		509	Table 13-66 Operating Procedure for TAUBnTTINm Input Position Detection Function, corrected		
		510	Figure 13-61 Operation Stop and Restart, corrected		
		537	Table 13-89 Operating Procedure for Delay Pulse Output Function (2/2), corrected		
		540	Figure 13-71 Block Diagram of AD Conversion Trigger Output Function Type 1, corrected		
		545	Figure 13-73 Block Diagram of One-Shot Pulse Output Function, corrected		
		559	Figure 13-79 Block Diagram of Triangle PWM Output Function, corrected		
		571	Figure 13-83 Block Diagram of Triangle PWM Output Function with Dead Time, corrected		
		573	Figure 13-84 General Timing Diagram of Triangle PWM Output Function with Dead Time, corrected		
		575	Table 13-111 Simultaneous Rewrite for Master Channels of Triangle PWM Output Function with Dead Time, corrected		
		577	Table 13-115 Simultaneous Rewrite Settings for Slave Channel 2 of Triangle PWM Output Function, corrected		
		579	Table 13-119 Simultaneous Rewrite Settings for Slave Channel 3 of Triangle PWM Output Function, corrected		
		592	Figure 13-91 Block Diagram of AD Conversion Trigger Output Function Type 2, corrected		
		601	Table 13-125 TAUBnCNTm Read Values after Re-Enabling Counter, corrected		
		605	Table 13-126 Description of TAUBnCMORm Register (4/4), corrected		
		607	Table 13-128 Description of TAUBnCSRm Register, corrected		
		610	13.21.4 (1) TAUBnTOE - Access, added description		
		612	13.21.4 (4) TAUBnTDE - Access, deleted		
		613	13.21.4 (5) TAUBnTDL - Access, added description		
		617	Table 13-144 Description of TAUBnRDT Register, added description		
		Section 14 Timer Array Unit J (TAUJ)			
		643	Table 14-9 Effect of TAUJnCMORm.TAUJnMD0 Bit on Generation of INTTAUJnIm When Counter Is Triggered, corrected		

REVISION HISTORY

V850E2/PG4-L User's Manual: Hardware

Rev.	Date	Description			
		Page	Summary		
1.01	Jun 25, 2014	658	14.12.3 (1) Overview - Functional description, deleted the description		
		658	Table 14-20 Effects of Overflow, corrected		
		667	Table 14-25 Effects of Overflow, corrected		
		675	14.12.5 (1) Overview - Functional description, deleted the description, and (2) Equations, corrected		
		676	Figure 14-34 General Timing Diagram of TAUJnTTINm Input Period Count Detection Function, corrected		
		677	Table 14-30 TAUJnCMORm Settings for TAUJnTTINm Input Period Count Detection Function, corrected		
		678	Table 14-33 Operating Procedure for TAUJnTTINm Input Period Count Detection Function, corrected		
		679	Figure 14-35 Operation Stop and Restart, corrected		
		680	14.12.6 (1) Overview - Functional description, deleted the description, and (2) Equations, corrected		
		681	Figure 14-37 General Timing Diagram of TAUJnTTINm Input Position Detection Function, corrected		
		682	Table 14-34 TAUJnCMORm Settings for TAUJnTTINm Input Position Detection Function, corrected		
		683	Table 14-37 Operating Procedure for TAUJnTTINm Input Position Detection Function, corrected		
		684	Figure 14-38 Operation Stop and Restart, corrected		
		704	Table 14-51 TAUJnCNTm Read Values after Counter Is Re-enabled, corrected		
		708	Table 14-52 Description of TAUJnCMORm Register (4/4), corrected		
		710	Table 14-54 Description of TAUJnCSRm Register, corrected		
		717	Table 14-66 Description of TAUJnRDT Register, added description		
				Section 15 TSG2 (TSG20)	
		722 to 723	Table 15-6 TSG2n Registers, corrected		
		734	Table 15-12 TSnCTL6 Register Contents (1/2), corrected		
		794	Table 15-45 List of Flags, corrected		
		805	15.7.9 TSnOPCI0 and TSnOPCI1 Signal Simultaneous Trigger Detection Flag (TSnTDF), corrected the title		
		811	15.8.1 (1) Interrupt Skipping Operation when TSnPIE = 1 and TSnVIE = 1 in TSnCTL4, corrected the figure		
		813	Figure 15-26 When TSnRMC = 0, TSnRIA = 0 in TSnCTL3 (without Reload Skipping), corrected		
		818	Figure 15-30 When TSnPIE = 1, TSnVIE = 1, and TSnRCC04 to TSnRCC00 = 00 _B in TSnCTL4, and TSnACC01 and TSnACC00 = 00 _B in TSnCTL5, corrected		
		819	Figure 15-31 When TSnPIE = 0, TSnVIE = 1, and TSnRCC04 to TSnRCC00 = 02 _B in TSnCTL4 and TSnACC01 and TSnACC00 = 00 _B in TSnCTL5, corrected		
		821	Figure 15-34 Example of Operation of A/D Conversion Trigger Skipping Function, corrected		
		826	15.10.2 Warning Interrupt Function, corrected the description		
		864	Table 15-62 Compare Registers and Dead Time Setting Register Functions in SPPWM Mode, corrected		

REVISION HISTORY

V850E2/PG4-L User's Manual: Hardware

Rev.	Date	Description			
		Page	Summary		
1.01	Jun 25, 2014	875	Table 15-68 Functions of Compare Registers and Dead Time Setting Registers in 120-DC Mode, changed		
		900	15.11.4 (12) (c) Change Timing of TSG2nO1 to TSG2nO6 Pins, corrected		
		902	15.11.4 (13) Basic Control Flow in 120-DC Modem, deleted description		
		904	Figure 15-83 Example of Switching from 120-DC Mode to Software Output Control Function, corrected		
		Section 17 OS Timer (OSTM)			
		943	Figure 17-4 Timing Diagram of Output Modes, corrected		
		Section 18 Encoder Timer (ENCA)			
		969, 971	Table 18-7 ENCAAnCTL Register Contents (1/3), (3/3), corrected		
		978	18.3 (7) ENCAAnCCR1 - Access, corrected		
		987	Figure 18-5 Counting Operation when ENCAAnCTL.ENCAAnUDS[1:0] = 00 _B , corrected		
		991	18.4.3 Control of Timer Counter Clearing, changed description, and Figure 18-9 Operations to Clear the Counter in Response to Encoder Clearing Input (ENCAAnEC), corrected		
		992	18.4.3 (1)-2 Operations for Counter Clearing and Capture in Response to Encoder Clearing Input (ENCAAnEC) - Setting condition, corrected		
		1003	18.4.6 Timer Counter Operation Start/Stop, deleted the description		
		1006	18.5.1 (4) Settings for the ENCAAnCCR1 Register, corrected		
		Section 19 Timer Option Module (TAPA)			
		1018	Table 19-6 Contents of the PIC0HIZCEN0 Register, changed Caution 2		
		1019	Table 19-7 Contents of the PIC0HIZCEN2 Register, changed Caution 2		
		1024	Table 19-10 Contents of the TAPAnCTL0 Register, corrected		
		1035	Figure 19-2 Operation of TAPAnTHZOUT0 when TAPAnDCM = 1, TAPAnDCP = 1, and TAPAnDCN = 0, corrected		
		1036	19.4.2 (4) Operating Procedure Example for Hi-Z Control in Response to Asynchronous Input, corrected		
		Section 20 CAN Controller (FCN)			
		1049	Table 20-7 Overview of Functions, corrected		
		1068	20.5.1 (5) FCNnDNBMRXk, corrected		
		1085	20.5.2 (12) FCNnCMLOSTR, added description to Caution		
		1089, 1090	20.5.3 (1) (b) FCNnMmDATyH, (c) FCNnMmDATzW, corrected		
		1104	20.7.3 Receive History List Function, corrected		
		1112	20.8.2 Transmit History List Function, corrected		
		1116	20.8.4 (2) Transmission Abort Process in Normal Operating Mode with Automatic Block Transmission (ABT) added description		
		1122	20.9.3 Example of Using Power Save Modes, corrected		
		1150	Figure 20-25 Transmission Abort Processing other than the ABT transmission (Normal Operating Mode with ABT), changed the title		
		1158	Figure 20-29 Transmission Abort Processing with Transmission Abort Interrupt and Transmission Completion Flag, changed description		

REVISION HISTORY

V850E2/PG4-L User's Manual: Hardware

Rev.	Date	Description	
		Page	Summary
1.01	Jun 25, 2014	Section 21 Clocked Serial Interface G (CSIG)	
		1179	Figure 21-7 EDL Timing Diagram, corrected
		Section 22 Synchronous/Asynchronous Serial Interface H (UARTH)	
		1231	22.4 (11) URTHnRX, added Caution
		1236	22.4 (15) URTHnTX, added Caution
		1250 to 1251	22.6.4 Consecutive Two-Frame Transfer Mode, corrected
		1263	22.6.12 UARTHn reception - Reception start, and Reception errors, corrected
		Section 23 A/D Converter	
		1273	23.2 Functional Overview, corrected
		1274	Figure 23-1 ADCAn Block Diagram, added Note
		1275	23.3 Functional Description - Channels and channel groups, corrected
		1277	23.3.1 Basic Operation, corrected
		1278	23.3.2 Clock Usage, corrected Caution
		1281	23.3.4 A/D Conversion Modes, corrected table
		1282 to 1283	23.3.4 (1) One-shot Conversion Mode, added
		1285	23.3.5 Starting A/D Conversion (Start Triggers), changed description
		1296	Figure 23-15 Outline of Self-Diagnosis Functions, corrected
		1298	23.3.11 (1) Diagnosis of A/D Conversion Circuit, added description
		1299	23.3.11 (2) Diagnosis of Channel Multiplexer, added description
		1300	23.3.11 (3) Diagnosis of Analog Input Pins, changed Note 1
		1304	23.3.11 (4) Diagnosis of Channel Sample and Hold Circuit - Step 2, corrected
		1311	Figure 23-20 A/D Conversion Timing when Buffer Amplifier Function is Enabled, corrected
		1314	23.4.2 (1) ADCAnCTL0 - Access, added description
		1315	Table 23-7 ADCAnCTL0 Register Contents (2/2), added description
		1316	23.4.2 (2) ADCAnCTL1 - Access, added description
		1320	23.4.2 (5) ADCAnCNT - Access, added description
		1322 to 1323	23.4.2 (7) ADCAnSMCNT to (10) ADCAnDISCNT, corrected
		1327	23.4.3 (4) ADCAnSTC2 - Access, added description
		1335	Table 23-25 ADCAnDBiCRL Register Contents, corrected
		1338	Table 23-29 ADCAnLL Register Contents, added description
		1347	23.5.4 (6) Wiring and Equivalent Circuit (Reference), added the title
		Section 24 Peripheral Interconnection (PIC)	
		Throughout	Changed a function name (A/D trigger encoder capture function" to "Encoder capture trigger selection function")
		1368	Figure 24-2 Setting Flow, corrected
—	24.4.3.3 (6) Timer I/O Control Register 204 (PIC0REG 204), deleted		
1415	Figure 24-18 Operation Example of Trigger and Pulse Width Measurement Function (m = 0 to 2, k = 0, 1), corrected the title		
1417	Figure 24-19 Setting Flow (k = 0, l = 0, 1), corrected figure and the title		
1420	Table 24-24 TAUJ0 Setting (k = 0, 1), corrected the title		

REVISION HISTORY	V850E2/PG4-L User's Manual: Hardware
------------------	--------------------------------------

Rev.	Date	Description	
		Page	Summary
1.01	Jun 25, 2014	1422	24.4.5 Encoder Capture Trigger Selection Function, corrected
		1423	Table 24-27 PIC0REG30 Contents, corrected
		1425 to 1426	24.4.5.4 Example of Operation, added description and corrected
		1428 to 1429	24.4.5.5 (1) Setting Flow for Encoder Capture Operation by INTTAUB0Im, added
		1431	Table 24-31 PIC Setting (Using INTTAUB0Im), added
		Section 27 Electrical Characteristics	
		1495	27.2 Capacity, changed
		1505	27.6.3 Timing in Turning the Power Supply On and Off, changed figure
		1515	27.6.10 (b) Slave Mode, changed
		1536 to 1537	27.6.18 FLMD0 Pulse Timing Characteristics, changed
1.02	Jul 18, 2014	Section 27 Electrical Characteristics	
		1533	27.6.16 POF/LVI Characteristics, changed

V850E2/PG4-L User's Manual: Hardware

Publication Date: Rev.0.01 Mar 29, 2012
Rev.1.02 Jul 17, 2014

Published by: Renesas Electronics Corporation

**SALES OFFICES****Renesas Electronics Corporation**<http://www.renesas.com>Refer to "<http://www.renesas.com/>" for the latest and detailed information.**Renesas Electronics America Inc.**2801 Scott Boulevard Santa Clara, CA 95050-2549, U.S.A.
Tel: +1-408-588-6000, Fax: +1-408-588-6130**Renesas Electronics Canada Limited**1101 Nicholson Road, Newmarket, Ontario L3Y 9C3, Canada
Tel: +1-905-898-5441, Fax: +1-905-898-3220**Renesas Electronics Europe Limited**Dukes Meadow, Millboard Road, Bourne End, Buckinghamshire, SL8 5FH, U.K
Tel: +44-1628-585-100, Fax: +44-1628-585-900**Renesas Electronics Europe GmbH**Arcadiastrasse 10, 40472 Düsseldorf, Germany
Tel: +49-211-6503-0, Fax: +49-211-6503-1327**Renesas Electronics (China) Co., Ltd.**Room 1709, Quantum Plaza, No.27 ZhiChunLu Haidian District, Beijing 100191, P.R.China
Tel: +86-10-8235-1155, Fax: +86-10-8235-7679**Renesas Electronics (Shanghai) Co., Ltd.**Unit 301, Tower A, Central Towers, 555 Langao Road, Putuo District, Shanghai, P. R. China 200333
Tel: +86-21-2226-0888, Fax: +86-21-2226-0999**Renesas Electronics Hong Kong Limited**Unit 1601-1613, 16/F., Tower 2, Grand Century Place, 193 Prince Edward Road West, Mongkok, Kowloon, Hong Kong
Tel: +852-2265-6688, Fax: +852 2686-9022/9044**Renesas Electronics Taiwan Co., Ltd.**13F, No. 363, Fu Shing North Road, Taipei 10543, Taiwan
Tel: +886-2-8175-9600, Fax: +886 2-8175-9670**Renesas Electronics Singapore Pte. Ltd.**80 Bendemeer Road, Unit #06-02 Hyflux Innovation Centre, Singapore 339949
Tel: +65-6213-0200, Fax: +65-6213-0300**Renesas Electronics Malaysia Sdn.Bhd.**Unit 906, Block B, Menara Amcorp, Amcorp Trade Centre, No. 18, Jln Persiaran Barat, 46050 Petaling Jaya, Selangor Darul Ehsan, Malaysia
Tel: +60-3-7955-9390, Fax: +60-3-7955-9510**Renesas Electronics Korea Co., Ltd.**12F., 234 Teheran-ro, Gangnam-Ku, Seoul, 135-920, Korea
Tel: +82-2-558-3737, Fax: +82-2-558-5141

V850E2/PG4-L