

## Series 6000 Chip Data

Design devices for IzoT™ and LONWORKS® networks using the Series 6000 chips and Smart Transceivers.

Echelon, LONWORKS, LonTalk, Neuron, 3120, 3150, LNS, FTXL, Izot, ShortStack, and the Echelon logo are trademarks of Echelon Corporation that may be registered in the United States and other countries.

Other brand and product names are trademarks or registered trademarks of their respective holders.

Smart Transceivers, Neuron Chips, and other OEM Products were not designed for use in equipment or systems which involve danger to human health or safety or a risk of property damage and Echelon assumes no responsibility or liability for use of the Smart Transceivers or Neuron Chips in such applications.

Parts manufactured by vendors other than Echelon and referenced in this document have been described for illustrative purposes only, and may not have been tested by Echelon. It is the responsibility of the customer to determine the suitability of these parts for each application.

ECHELON MAKES AND YOU RECEIVE NO WARRANTIES OR CONDITIONS, EXPRESS, IMPLIED, STATUTORY OR IN ANY COMMUNICATION WITH YOU, AND ECHELON SPECIFICALLY DISCLAIMS ANY IMPLIED WARRANTY OF MERCHANTABILITY OR FITNESS FOR A PARTICULAR PURPOSE.

Except as expressly permitted herein, no part of this publication may be reproduced, stored in a retrieval system, or transmitted, in any form or by any means, electronic, mechanical, photocopying, recording, or otherwise, without the prior written permission of Echelon Corporation.

Printed in the United States of America.  
Copyright © 2014, 2015, Echelon Corporation.

Echelon Corporation  
[www.echelon.com](http://www.echelon.com)

---

# Welcome

Echelon's FT 6000 Free Topology Smart Transceiver is the latest addition to Echelon's FT Smart Transceiver family.

The FT 6000 Smart Transceivers includes a network transceiver that is fully compatible with the TP/FT-10 channel. The free topology transceiver supports polarity-insensitive cabling using a star, bus, daisy chain, loop, or combined topologies. This flexibility frees the installer from the need to adhere to a strict set of wiring rules. Free topology wiring reduces the time and expense of device installation by allowing the wiring to be installed in the most expeditious and cost-effective manner. It also simplifies network expansion by eliminating restrictions on wire routing, splicing, and device placement.

The Neuron 6000 Processor has similar performance, robustness, and low cost as the FT 6000 Smart Transceiver, but you can use it with a number of different types of network transceivers so that you can integrate different channel types (such as the TP/XF-1250 channel) into a LONWORKS network.

Together, the FT 6000 Smart Transceiver and the Neuron 6000 Processor are part of a family of products, collectively known as Series 6000 chips.

This document provides technical specifications for the electrical interfaces, mechanical interfaces, and operating environment characteristics for the FT 6000 Smart Transceiver and Neuron 6000 Processor.

This manual does not describe Echelon's Power Line Smart Transceivers. For more information about that technology, see the *PL 3120 / PL 3150 / PL 3170 Power Line Smart Transceiver Data Book* (005-0193-01A).

---

## Audience

This manual provides specifications and user instructions for engineers who develop applications and devices that use FT 6000 Smart Transceivers or Neuron 6000 Processors, and for users of network interfaces based on the FT Smart Transceivers or Neuron Chips.

---

## What's New for Echelon's Smart Transceivers and Neuron Chips

Echelon's FT 6000 Smart Transceiver and Neuron 6000 Processor include new features and functions compared with Echelon's FT 5000 Smart Transceiver and Neuron 5000 Processor. This section describes some of the major new features and functions of the Series 6000 chips.

### New Memory Layout

Series 6000 chips use only an external SPI flash of at least 512KB. This flash contains active and standby bootloaders, system images, and applications. It also holds persistent system and application data, as well as data logs. Larger applications can be supported because certain code can be designated to be "transient" which means it is brought into RAM for execution out of flash only on demand. See the Memory Architecture section in Chapter 2 for a full description.

The memory map for a Series 6000 chip is “auto-tuned”. This means that the linker decides how to partition the RAM based upon the needs placed on it by the application. The user does not need to specify the address ranges used for each type of memory (code vs data vs persistent data).

### IP Support

The system image for the Series 6000 chip contains a UDP/IP (V4) stack along with ICMP and SNMP (V1). In conjunction with an IzoT Router, the device can communicate using LonTalk/IP, BACnet/IP, be pinged from a device on the Ethernet side of the IzoT router or monitored via SNMP from a standard SNMP client such as Solar Winds. The device can also get an IP address via DHCP from the IzoT Router. Furthermore, one can use a socket API on a Windows or Linux PC (or any device that supports sockets) to open a UDP socket connection to a Series 6000 device through an IzoT Router.

### BACnet Support

The larger application space allows an application to include a BACnet library that enables a device to be monitored and controlled in a traditional manner from an OpenLNS based tool and simultaneously from a standard BACnet workstation using BACnet/IP.

### Extended Address Table

Series 6000 chips use system firmware version 21 or later which supports up to 254 address table entries for Neuron hosted devices (devices without a host microprocessor). The entries beyond 15 are used by OpenLNS Server 4.02 and the IzoT Commissioning Tool.

### Compiler Enhancements

The Neuron C compiler supports auto initializers for scalars (e.g., int i=0;) Furthermore, the Neuron C preprocessor has been replaced by a standard preprocessor called MCPP (<http://mcpp.sourceforge.net>).

---

## Related Documentation

The following table lists related Echelon documentation that can be useful when designing or using Series 6000 chips with LONWORKS devices and LONWORKS networks. The table includes documentation for the IzoT NodeBuilder Development Tool, the primary development tools for LONWORKS devices. All of these manuals are available from the Echelon Web site ([www.echelon.com](http://www.echelon.com)).

**Table 1.** Related Documentation

Title	Part Number	Description
FT 6000 EVB Hardware Guide	078-0504-01A	This manual describes the hardware for the FT 6000 EVB evaluation boards that are included with the FT 6000 EVK.
FT 6000 EVB Schematic	012-1460-51A	This document provides the schematic diagrams for the FT 6000 EVB

Title	Part Number	Description
Introduction to the LONWORKS Platform	078-0183-01B	This manual provides an introduction to the ISO/IEC 14908 (ANSI/EIA/CEA-709.1 and EN 14908) Control Networking Protocol, and provides a high-level introduction to LONWORKS® networks and the tools and components that are used for developing, installing, operating, and maintaining them.
IzoT NodeBuilder User's Guide	078-0516-01A	This manual describes how to develop LONWORKS devices and applications using the IzoT NodeBuilder Development Tool.
I/O Model Reference for Smart Transceivers and Neuron Chips	078-0392-01C	This manual provides information about the I/O models used by Echelon's Neuron Chips and Smart Transceivers.  It includes hardware and software considerations for each of the I/O models.
Neuron Assembly Language Reference	078-0399-01B	This manual describes the Neuron assembly language and how to write Neuron assembly language functions.
Neuron C Programmer's Guide	078-0002-01I	This manual describes how to write programs using the Neuron C Version 2.2 programming language.
Neuron C Reference Guide	078-0140-01G	This manual provides reference info for writing programs using the Neuron C Version 2.2 programming language.
IzoT BACnet Developer's Guide	078-0507-01A	This manual details how to develop a BACnet/IP application on a Series 6000 device.
NodeLoad User's Guide	078-0286-01G	This manual details the usage of the NodeLoad application.
NodeUtil User's Guide	078-0438-01B	This manual details the usage of the NodeUtil application.

For information about previous generation Smart Transceivers, see the Echelon *FT 3120 / FT 3150 Smart Transceiver Data Book* or the *Series 5000 Chip Data Book*.

All of the Echelon product documentation is available in Adobe® PDF format. To view the PDF files, you must have a current version of the Adobe Reader®. Most Echelon products include the English-language version of the Adobe Reader; you can download other language versions from Adobe at: [www.adobe.com/products/acrobat/readstep2.html](http://www.adobe.com/products/acrobat/readstep2.html).

---

## Standards Documents Referenced in this Manual

This manual refers to the following standards documents:

- American Society for Testing and Materials (ASTM) B258 - 02(2008) Standard Specification for Standard Nominal Diameters and Cross-Sectional Areas of AWG Sizes of Solid Round Wires Used as Electrical Conductors. [www.astm.org/Standards/B258.htm](http://www.astm.org/Standards/B258.htm)
- Comité européen de normalisation electrotechnique<sup>1</sup> (CENELEC) EN 55022 – Information technology equipment – Radio disturbance characteristics – Limits and methods of measurement.
- Comité international spécial des perturbations radioélectriques<sup>2</sup> (CISPR) 22 – Information Technology Equipment – Radio Disturbance Characteristics – Limits and Methods of Measurement.
- Electrostatic Discharge Association standard ESD STM5.1: Electrostatic Discharge Sensitivity Testing – Human Body Model. [www.esda.org/freedownloads.html](http://www.esda.org/freedownloads.html)
- European Union Restriction of Hazardous Substances (RoHS) Directive 2002/95/EC. [europa.eu.int/eur-lex/pri/en/oj/dat/2003/l\\_037/l\\_03720030213en00190023.pdf](http://europa.eu.int/eur-lex/pri/en/oj/dat/2003/l_037/l_03720030213en00190023.pdf)
- Comité européen de normalisation<sup>3</sup> (CEN) Electromagnetic Compatibility (EMC) standards (see **Table 2**).
- International Organization for Standardization (ISO) and International Electrotechnical Commission (IEC) standard ISO/IEC 14908 Control Network Protocol
- Institute of Electrical and Electronics Engineers (IEEE) Standard Test Access Port and Boundary-Scan Architecture (IEEE 1149.1-1990). [www.ieee.org/web/standards/home/index.html](http://www.ieee.org/web/standards/home/index.html).
- Institute for Printed Circuits (IPC) / Joint Electron Device Engineering Council (JEDEC) Solid State Technology Association standard: IPC/JEDEC J-STD-020D.1 – Moisture/Reflow Sensitivity Classification for Nonhermetic Solid State Surface Mount Devices. [www.jedec.org/download/search/JSTD020D-01.pdf](http://www.jedec.org/download/search/JSTD020D-01.pdf)
- Title 47 of the Code of Federal Regulations (CFR) Part 15, Radio Frequency Devices. [www.fcc.gov/oet/info/rules/](http://www.fcc.gov/oet/info/rules/)
- US Military Standard MIL-STD-883 Test Method Standard, Microcircuits: Method 3015.7, Electrostatic Discharge Sensitivity Classification.

---

<sup>1</sup> European Committee for Electrotechnical Standardization

<sup>2</sup> International Special Committee on Radio Interference

<sup>3</sup> European Committee for Standardization

You can purchase copies of CENELEC documents, IEC EMC standards, ISO standards, US Military Standards, and CISPR documents from the Information Handling Services (IHS) Global page at: [global.ihs.com](http://global.ihs.com). IEC EMC standards are also available from the IEC at: [www.iec.ch](http://www.iec.ch).

**Table 2.** IEC Electromagnetic Compatibility (EMC) Standards

Standard	Title
IEC 61000-4-1	Electromagnetic compatibility (EMC) - Part 4-1: Testing and measurement techniques - Overview of IEC 61000-4 series
IEC 61000-4-2	Electromagnetic compatibility (EMC) - Part 4-2: Testing and measurement techniques - Electrostatic discharge immunity test
IEC 61000-4-3	Electromagnetic compatibility (EMC) - Part 4-3 : Testing and measurement techniques - Radiated, radio-frequency, electromagnetic field immunity test
IEC 61000-4-4	Electromagnetic compatibility (EMC) - Part 4-4: Testing and measurement techniques - Electrical fast transient/burst immunity test
IEC 61000-4-5	Electromagnetic compatibility (EMC) - Part 4-5: Testing and measurement techniques - Surge immunity test
IEC 61000-4-6	Electromagnetic compatibility (EMC) - Part 4-6: Testing and measurement techniques - Immunity to conducted disturbances, induced by radio-frequency fields





## Contents

<b>Welcome .....</b>	<b>iii</b>
Audience .....	iii
What's New for Echelon's Smart Transceivers and Neuron Chips.....	iii
Related Documentation .....	iv
Standards Documents Referenced in this Manual.....	vi
<b>1.....</b>	<b>1</b>
Introduction .....	1
Product Family Overview .....	2
Development Resources for Series 6000 Chips .....	2
Overview of the IzoT Platform .....	4
Key Features of Series 6000 Chips .....	8
Specification Summaries .....	9
<b>2.....</b>	<b>13</b>
Hardware Resources.....	13
Series 6000 Architecture .....	14
Memory Architecture .....	23
Serial Peripheral Interface (SPI) .....	26
Non-Volatile Memory Integrity .....	27
Device Support .....	28
Device Programming.....	29
Recovering a Device .....	29
JTAG Interface.....	31
Operating Conditions.....	32
Pin Assignments .....	33
Pin Connections .....	39
Characteristics of the Digital Pins.....	43
Communications Port (CP) Pins for the Neuron 6000 Processor.....	44
Collision Detection for Single-Ended Mode .....	48
Beta 1 and Beta 2 Timeslots in Single-Ended Mode .....	48
Network Connection.....	54
Comparison with FT 3120 or FT 3150 Devices .....	55
Comparison with Series 5000 Devices .....	56
Comparison with the FTT-10A Transceiver .....	56
TPT/XF-1250 Transceivers .....	57
EIA-485 Transceivers .....	58
LPT-11 Link Power Transceivers.....	59
Clock Requirements .....	61
Reset Function .....	63
Power-Up and LVI .....	65
Watchdog Timer .....	65
Traps .....	66
Software-Controlled Reset.....	66
SVC~ Pin .....	69
Integrity Mechanisms .....	70
<b>3.....</b>	<b>73</b>
Hardware Design Considerations .....	73
PC Board Layout Guidelines.....	74

<b>4</b> .....	<b>77</b>
Design and Test for Electromagnetic Compatibility .....	77
Overview .....	78
Achieving High Immunity .....	79
Electrostatic Discharge .....	79
Electromagnetic Interference .....	80
Radiated and Conducted Immunity .....	82
Surge and Burst .....	85
Lightning Protection .....	86
Avoiding Magnetic Field Interference .....	88
Summary and Testing Results .....	89
<b>5</b> .....	<b>91</b>
Network Cabling and Connections .....	91
Network Connection.....	92
Network Topology Overview.....	92
System Performance and Cable Selection .....	94
Cable Termination and Shield Grounding.....	96
<b>6</b> .....	<b>99</b>
Input/Output Interfaces for the .....	99
Overview .....	100
Two 16-Bit Timer/Counters.....	100
Summary of the Available I/O Objects.....	101
Hardware Considerations.....	109
<b>7</b> .....	<b>113</b>
Programming Considerations .....	113
Application Program Development .....	114
IzoT NodeBuilder Development Tool .....	114
SNMP Support .....	116
Migrating from earlier Neuron Chips .....	117
<b>A</b> .....	<b>119</b>
Series 6000 Design Checklists .....	119
Checklist 1: Series 6000 Chip Connections .....	120
Checklist 2: FT 6000 Smart Transceiver Connections .....	122
Checklist 3: Neuron 6000 Processor Connections .....	123
Checklist 4: Power Supply .....	124
Checklist 5: Device PCB Layout.....	125
Checklist 6: Network Cabling and Termination .....	126
Checklist 7: Device Programming.....	127
<b>B</b> .....	<b>129</b>
Qualified TP/FT-10 Cable .....	129
Introduction.....	130
Qualified Cables .....	130
<b>C</b> .....	<b>135</b>
FT-X3 Communications.....	135
Transformer Pinout.....	136
Transformer Electrical Connections .....	137
Transformer Pad Layout .....	138

<b>D</b> .....	<b>141</b>
Handling and Manufacturing .....	141
Application Considerations.....	142
Board Soldering Considerations.....	146
General ESD Handling Guidelines .....	147
Power Distribution and Decoupling Capacitors .....	151
Recommended Bypass Capacitor Placement .....	151
<b>E</b> .....	<b>155</b>
Example Schematic .....	155
Example Schematic.....	156
BOM for Example Schematic .....	158
<b>F</b> .....	<b>160</b>
Vendor Contact Information .....	160
Vendor Information.....	161



# 1

## Introduction

This chapter introduces the Series 6000 of products, LONWORKS networks, and free topology networking.

---

## Product Family Overview

Echelon designed the original Neuron Chip as a system-on-a-chip semiconductor device to provide intelligence and networking capabilities to low-cost control devices. Through a unique combination of hardware and firmware, the Neuron Chip provided all of the key functions necessary to process inputs from sensors and control devices intelligently, and to propagate control information across a variety of network media. Since then, Echelon has continued to develop and improve the families of products that are based on the Neuron Chip.

This book describes the newest additions to the Neuron families of products:

- FT 6000 Free Topology Smart Transceivers
- Neuron 6000 Processors

This book describes these products generically as “Series 6000 chips”.

All Series 6000 chips include multiple processors, read-write and read-only memory (RAM and ROM), communication subsystems, and I/O subsystems. Each Series 6000 chip includes a processor core for running applications and managing network communications, memory, I/O, and a 48-bit identification number (the Neuron ID) that is unique to every device. In addition, all Series 6000 chips include the Neuron system firmware, which provides an implementation of the LonTalk® protocol, along with I/O libraries, and a task scheduler for application-program management. The device manufacturer provides the application code and the I/O devices that complete a LONWORKS device.

The Neuron 6000 Processor provides a media-independent communications port which permits short distance Neuron Chip-to-Neuron Chip communications, and can also be used with external line drivers and transceivers of almost any type.

---

### *FT 6000 Smart Transceiver*

The FT 6000 Free Topology Smart Transceiver integrates a high performance Neuron core with a free topology twisted pair transceiver. Together with the FT-X3 Communications Transformer and inexpensive serial memories, the FT 6000 Smart Transceiver provides a low-cost, high-performance solution.

---

### *Neuron 6000 Processor*

The Neuron 6000 Processor provides a media-independent communications port that supports external transceivers for EIA-485 or TP/XF-1250 channels, using an external transceiver circuit. The Neuron 6000 Processor can also connect to a link-power TP/FT-10 channel using a LONWORKS LPT-11 Link Power Transceiver. The Neuron 6000 Processor provides a lower-cost, higher-performance alternative to the previous generation of Neuron Chips.

---

## Development Resources for Series 6000 Chips

A wide assortment of technical documentation, diagnostic tools, support programs, and training courses are available to assist customers with their projects. Additionally, Echelon offers fee-based pre-production design reviews of customers' products, schematics, PCB layouts, and bills of material to verify that they comply with published guidelines.

# Introduction to LONWORKS Networks

In almost every industry, there is a trend away from proprietary control schemes and centralized systems. The migration towards open, distributed, peer-to-peer networks is being driven by the need for interoperability, robust technology, faster development time, and scale economies.

With thousands of application developers and millions of devices installed worldwide, the LONWORKS system is the leading open solution for building and home automation, industrial, transportation, and public utility control networks. A control network is any group of devices working in a peer-to-peer fashion to monitor sensors, control actuators, communicate reliably, manage network operation, and provide complete access to network data. A LONWORKS network provides communications and complete access to control network data from any device in the network.

The communications protocol used for LONWORKS networks is the ISO/IEC 14908-1 (ANSI/CEA 709.1-B and EN14908.1) Control Network Protocol. This protocol is an international standard seven-layer protocol that has been optimized for control applications and is based on the Open Systems Interconnection (OSI) Basic Reference Model (the OSI Model, ISO standard 7498-1). The OSI Model describes computer network communications through the seven abstract layers described in **Table 3**. The implementation of these layers in a LONWORKS device provides standardized interconnectivity for devices within a LONWORKS network.

**Table 3.** LONWORKS Network Protocol Layers

OSI Layer	Purpose	Services Provided
7	Application	Application compatibility
		Network configuration, self-installation, network diagnostics, file transfer, application configuration, application specification, alarms, data logging, scheduling
6	Presentation	Data interpretation
		Network variables, application messages, foreign frame transmission
5	Session	Control
		Request/response, authentication
4	Transport	End-to-end communication reliability
		Acknowledged and unacknowledged message delivery, common ordering, duplicate detection
3	Network	Destination addressing
		Unicast and multicast addressing, routers
2	Data Link	Media access and framing
		Framing, data encoding, CRC error checking, predictive carrier sense multiple access (CSMA), collision avoidance, priority, collision detection
1	Physical	Electrical interconnect
		Media-specific interfaces and modulation schemes

Echelon's implementation of the ISO/IEC 14908-1 Control Network Protocol is called the *LonTalk protocol*. Echelon provides implementations of the LonTalk protocol with several product offerings, including the Neuron system firmware, OpenLNS<sup>®</sup> Server, LNS remote client, SmartServers, and the ShortStack<sup>®</sup> Micro Server. This document refers to the ISO/IEC 14908-1 Control Network Protocol as the "LonTalk protocol", although other interoperable implementations exist.

A LONWORKS system is based on the following concepts:

- Control systems have many common requirements regardless of application.
- A networked control system is significantly more powerful, flexible, and scalable than a non-networked control system.
- Businesses can save and make more money with control networks over the long term than they can with non-networked control systems.

LONWORKS networks provide a complete suite of messaging services, including end-to-end acknowledgement, authentication, and priority message delivery. Network management services allow network tools to interact with devices over the network, including local or remote reconfiguration of network addresses and parameters, downloading of application programs, reporting of network problems, and start/stop/reset of device application programs.

LONWORKS networks range in sophistication from small networks embedded in machines to large networks with thousands of devices controlling fusion lasers, paper manufacturing machines, or building automation systems. LONWORKS networks are used in buildings, trains, airplanes, factories, and hundreds of other processes. Manufacturers are using open, off-the-shelf chips, operating systems, and parts to build products that feature improved reliability, flexibility, system cost, and performance.

Echelon manufactures many LONWORKS products to help developers, system integrators, and end users implement LONWORKS networks. These products provide a complete LONWORKS solution including development tools, network management software, power line and twisted pair transceivers and control modules, network interfaces, technical support and training.

See *Introduction to the LonWorks Platform (078-0183-01B)* for more information about LONWORKS networks.

---

## Overview of the IzoT Platform

The IzoT<sup>™</sup> Platform is an IP-enabled family of chips, stacks, interfaces, and management software that enables the development of devices, peer-to-peer device communities, and applications for the Industrial Internet of Things. Unlike consumer-grade platforms, the IzoT Platform comprehensively addresses unique IIoT requirements such as autonomous control, multi-cast addressing and industrial-strength reliability.

The IzoT platform builds on LonWorks networking technology by adding native IP support down to individual field devices, with Neuron 6050 and FT 6050 based devices providing the option of backwards compatibility with ISO/IEC 14908-1.



Series 6000 based field devices are capable of running multiple protocols (LonTalk, LonTalk/IP, BACnet/IP, SNMP, ICMP with UDP sockets available) with a variety of transceiver options.

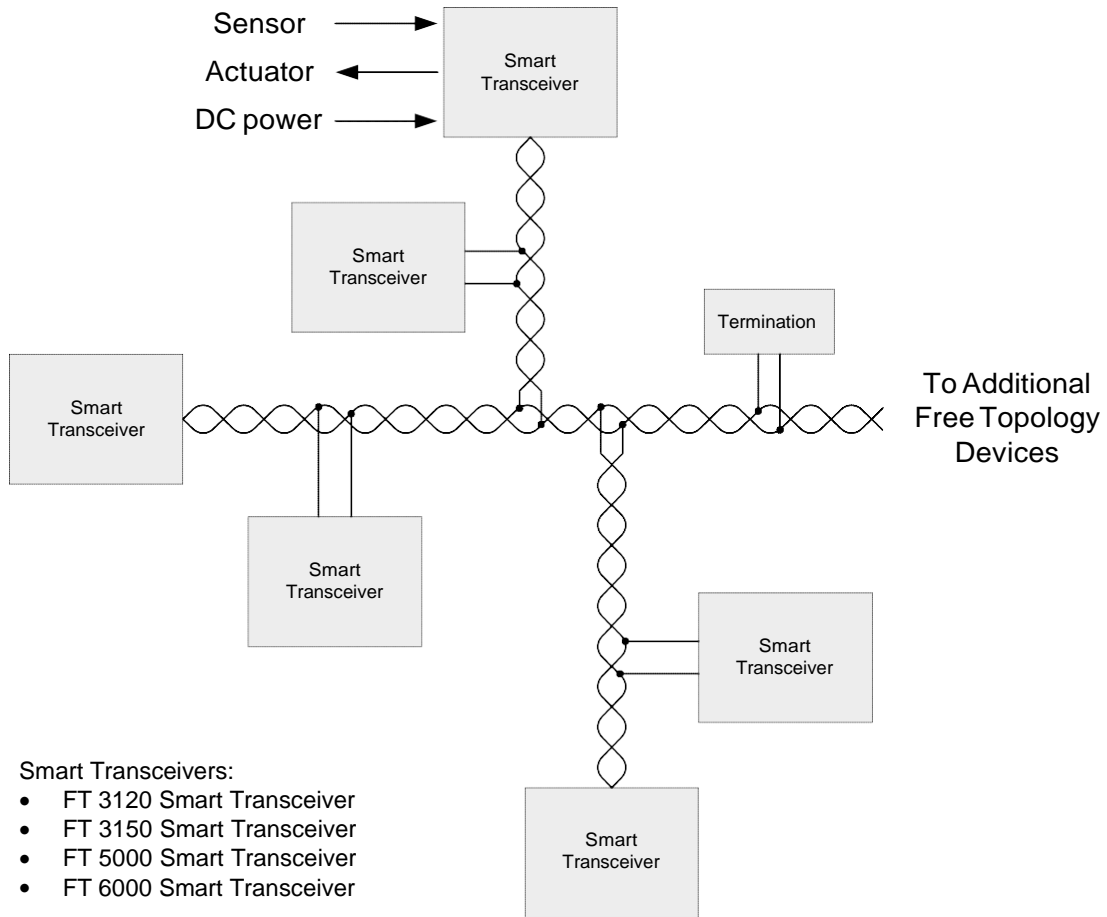
---

## Overview of Free Topology Technology

A conventional control system using bus topology wiring (such as an EIA-485 network) consists of a network of sensors and actuators that are interconnected using a twisted wire pair. In accordance with EIA-485 guidelines, all of the devices must be wired in a bus topology to limit electrical reflections and to ensure reliable communications. There is a high cost associated with installing and maintaining the cable plant that links together the devices of an EIA-485-based control system. Bus topology wiring is more time consuming and expensive to install, because the installer is unable to branch or star the wiring where convenient. All devices must be connected directly to the main bus.

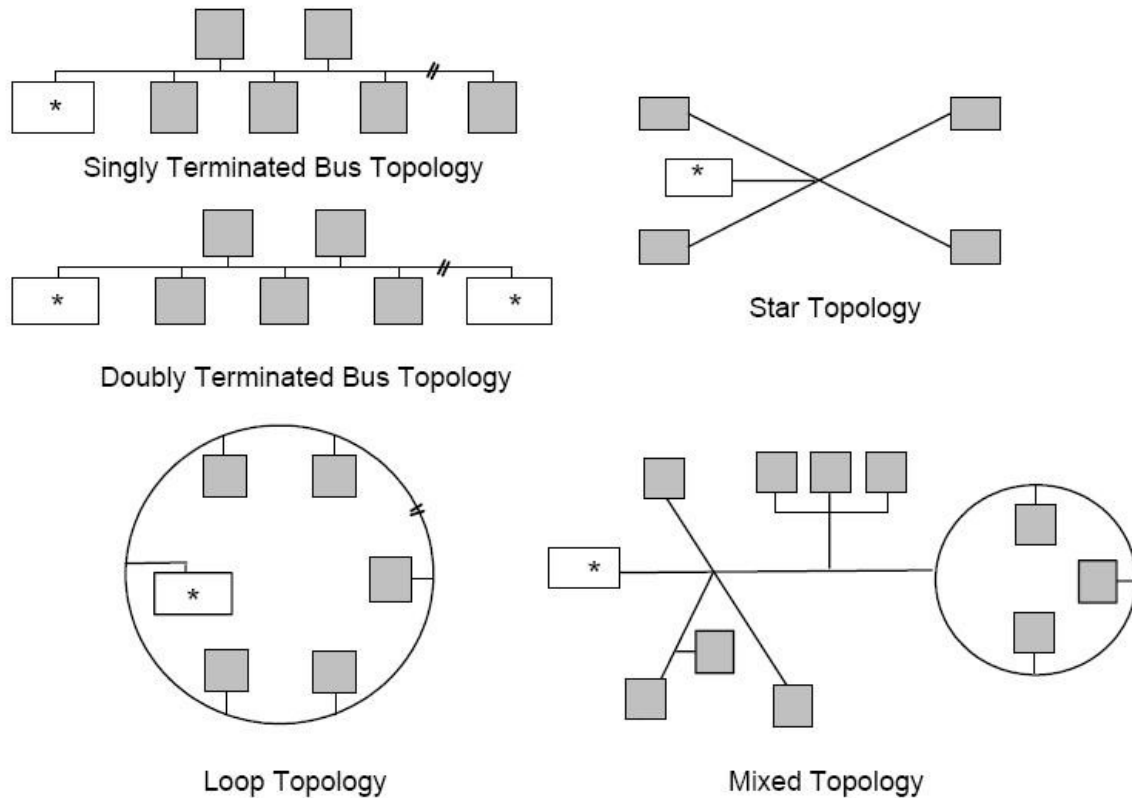
The best solution to reduce installation and maintenance costs and to simplify system modifications is to use a free topology communications system. Echelon's free topology transceiver technology offers such a solution, providing an elegant and inexpensive method of interconnecting the different elements of a distributed control system.

A free topology architecture allows the installer to wire the control devices with virtually no topology restrictions. Power is supplied by a local DC power supply located at each device as shown in **Figure 1**.



**Figure 1.** Free Topology Transceiver System

Unlike bus wiring designs, the free topology FT Smart Transceivers or Neuron Chips with associated transceivers use a wiring scheme that supports star, loop, or bus wiring (see **Figure 2**).



(\* = Termination. The actual termination circuit will vary by topology.)

**Figure 2.** Typical Wiring Topologies Supported by FT Smart Transceivers

This design has many advantages:

- The installer is free to select the method of wiring that best suits the installation, reducing the need for advanced planning and allowing last minute changes at the installation site.
- If installers have been trained to use one style of wiring for all installations, free topology technology can be introduced without requiring retraining.
- Retrofit installations with existing wiring plants can be accommodated with minimal, if any, rewiring. This capability ensures that FT Smart Transceiver technology can be adapted to both old and new projects.
- Free topology permits FT Smart Transceiver or Neuron Chip systems to be expanded in the future by simply tapping into the existing wiring where it is most convenient to do so. This reduces the time and expense of system expansion, and from the customer's perspective, keeps down the life-cycle cost of the free topology network.

---

## Key Features of Series 6000 Chips

Series 6000 chips include the following key features:

- Provide a high performance Neuron Core, with internal system clock rates up to 80 MHz
- Require as little as 30 mW of power for operations
- Packaged as a 7 mm by 7 mm 48-pin quad flat no leads (QFN) chip
- Include a serial memory interface for inexpensive external flash non-volatile memory
- Support up to 254 network variables (NVs) for FT 6000 Smart Transceivers and Neuron 6000 Processors, without the need for a host microprocessor
- Support user-programmable interrupts to provide fast response time to external events
- Provide an interface for the Institute of Electrical and Electronics Engineers (IEEE) Standard Test Access Port and Boundary-Scan Architecture (IEEE 1149.1-1990) of the Joint Test Action Group (JTAG) to allow a Series 6000 chip to be included in the boundary-scan chain for device production tests
- Include 12 I/O pins with 35 programmable standard I/O models that support both 5 V and 3.3 V I/O operation
- Support up to 256 KB of user application code space (with a 1MB external flash)
- Include 64 KB RAM (of which 44 KB is user accessible) and 16 KB of ROM on-chip
- Include a unique 48-bit MAC ID in every device for network installation and management
- Support a  $-40^{\circ}\text{C}$  to  $+85^{\circ}\text{C}$  operating temperature range
- Compliant with the European Union Restriction of Hazardous Substances (RoHS) Directive 2002/95/EC.

---

## *Additional Key Features for FT 6000 Smart Transceivers*

FT 6000 Smart Transceivers include the following additional key features:

- Support polarity insensitive free topology star, daisy chain, bus, loop, or mixed topology wiring for TP/FT-10 channels
- Compliant with TP/FT-10 channels that currently use FT 3120 Smart Transceivers, FT 3150 Smart Transceivers, FTT-10A transceivers, LPT-11 transceivers or FT-5000 Transceivers
- Provide very high common-mode noise immunity

---

## Specification Summaries

The following sections summarize the specifications for FT 6000 Smart Transceivers and Neuron 6000 Processors.

---

### *Specification Summary for FT 6000 Smart Transceivers*

**Table 4** summarizes the specifications for the FT 6000 Smart Transceiver.

**Table 4.** FT 6000 Smart Transceiver Specification Summary

<b>Description</b>	<b>Specification</b>
Data communications type	Differential Manchester encoding
Transmission speed	78 kilobits per second
Network polarity	Polarity insensitive
Number of transceivers per network segment	Up to 64
Network wiring	24 to 16 AWG twisted pair
Network length for free topology	Varies by wire type. <ul style="list-style-type: none"><li>• Up to 1000 m (3280 ft) maximum total wire with one repeater</li><li>• Up to 500 m (1640 ft) maximum total wire with no repeaters</li></ul>
Network length for bus topology	Varies by wire type. <ul style="list-style-type: none"><li>• 5400 m (17 710 ft) maximum total wire with one repeater</li><li>• 2700 m (8850 ft) maximum total wire with no repeaters</li></ul>
Maximum stub length for bus topology	3 m (9.8 ft)
Network termination	One terminator for free topology Two terminators for bus topology
Voltage for FT 6000 Smart Transceiver	3.3 V $\pm$ 5%
Operating temperature	-40 °C to +85 °C

<b>Description</b>	<b>Specification</b>
Reflow soldering temperature profile	Refer to Joint Industry Standard document <i>IPC/JEDEC J-STD-020D.1</i> (March 2008)
Peak reflow soldering temperature	260 °C
Package type	48-pin QFN
RoHS compliant	Yes
EMI	Designed to comply with FCC Part 15 Subpart B and EN 55022 Level B
ESD	Designed to comply with EN 61000-4-2, Level 4
Radiated Electromagnetic Susceptibility	Designed to comply with EN 61000-4-3, Level 3
Fast Transient/Burst Immunity	Designed to comply with EN 61000-4-4, Level 4
Surge Immunity	Designed to comply with EN 61000-4-5, Level 3
Conducted RF Immunity	Designed to comply with EN 61000-4-6, Level 3

**Table 5** summarizes the specifications for the FT-X3 Communications Transformer.

**Table 5.** FT-X3 Communications Transformer Specification Summary

<b>Description</b>	<b>Specification</b>
Operating humidity	25-90% RH @50 °C, non-condensing
Non-operating humidity	95% RH @ 50 °C, non-condensing
Vibration	1.5 g peak-to-peak, 8 Hz to 2 kHz
Mechanical shock	100 g (peak)
Reflow soldering temperature profile	Refer to Joint Industry Standard document <i>IPC/JEDEC J-STD-020D.1</i> (March 2008)
Peak reflow soldering temperature	245 °C

---

## Specification Summary for Neuron 6000 Processors

Table 6 summarizes the specifications for the Neuron 6000 Processor.

**Table 6.** Neuron 6000 Processor Specification Summary

Description	Specification
Transmission speed	Depends on network transceiver: <ul style="list-style-type: none"><li>• 78 kbit/s for TP/FT-10 channel</li><li>• 1250 kbit/s for TP/XF-1250 channel</li><li>• See EIA-485 channel specification for transmission speed characteristics</li></ul>
Voltage for Neuron 6000 Processor	3.3 V $\pm$ 10%
Operating temperature	-40 °C to +85 °C
Reflow soldering temperature profile	Refer to Joint Industry Standard document <i>IPC/JEDEC J-STD-020D.1</i> (March 2008)
Peak reflow soldering temperature	260 °C
Package type	48-pin QFN
RoHS compliant	Yes
EMC	Depends on network transceiver





# 2

## Hardware Resources

This chapter provides an overview of the hardware resources for an FT 6000 Smart Transceiver and a Neuron 6000 Processor, including the overall chip architecture, memory interface, operating parameters, pinouts, network connection, clock requirements, the reset function, and integrity mechanisms.

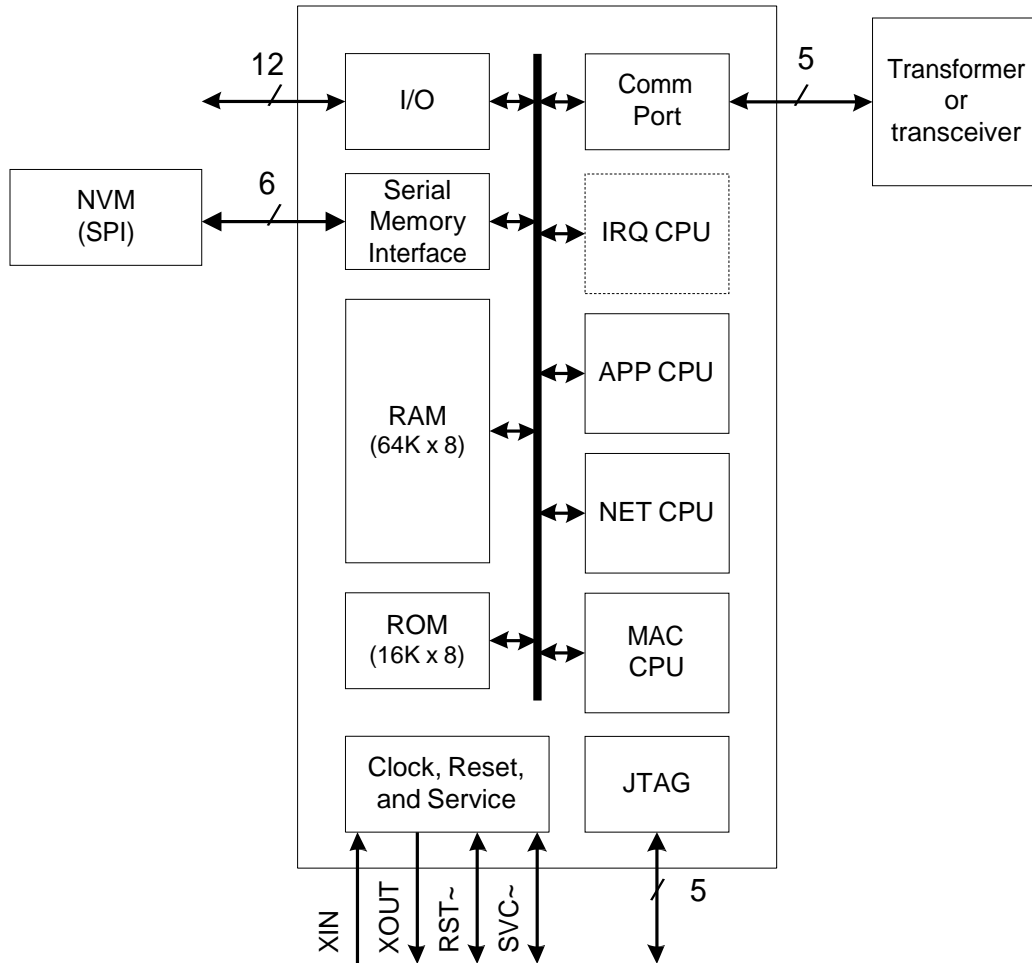
---

## Series 6000 Architecture

The main components of the architecture for a Series 6000 chip, as shown in **Figure 3** include:

- CPUs — a Series 6000 chip includes three processors to manage operation of the chip, the network, and the user application. At higher clock rates, there is also a separate processor to handle interrupts.
- ROM — a Series 6000 chip includes 16 KB of read-only memory (ROM), which holds the a system firmware image used for booting a system image from flash.
- RAM — a Series 6000 chip includes 64 KB of random access memory (RAM), which stores user applications and data. The RAM is partitioned according to a logical memory map so that the amount that is available for user applications and data is less than 64 KB. See *Memory Map* for information about how the RAM is configured.
- Serial memory interface — this interface manages the external non-volatile memory (NVM) using the serial peripheral interface (SPI).
- Communications port — the communications port provides network access for the chip. For an FT 6000 Smart Transceiver, this port connects to an FT-X3 Communications Transformer. For a Neuron 6000 Processor, this port connects to an external transceiver.
- I/O — 12 dedicated I/O pins (see *Characteristics of the Digital Pins*).
- Clock, reset, and service — on-chip clock, phase-locked loop (PLL), reset, and service-pin functions.
- JTAG — a Series 6000 chip includes a JTAG (IEEE 1149.1) interface for boundary scan operations. See *JTAG Interface*.

The pinout labels shown in **Figure 3** are described in *Pin Assignments*.



**Figure 3.** Series 6000 Chip Architecture

---

## Neuron Processor Architecture

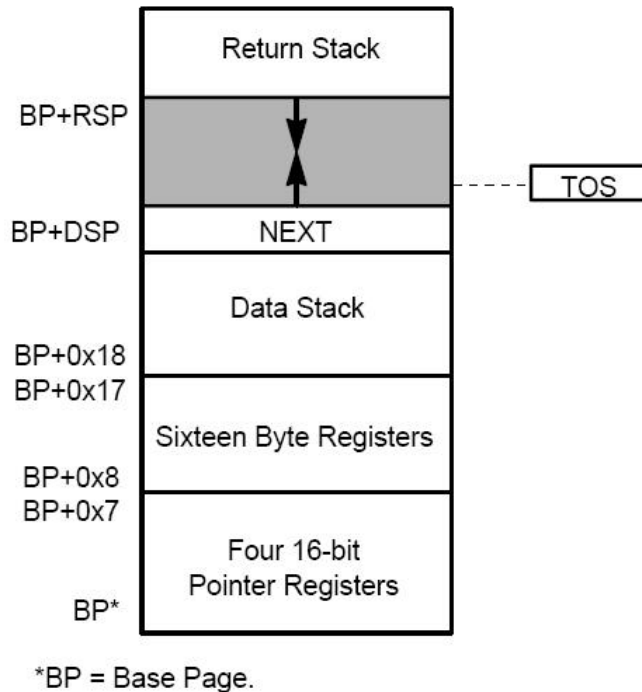
The basic Neuron processor architecture is stack-oriented:

- An 8-bit-wide stack is used for data references, and the arithmetic-logic unit (ALU) operates on the TOS (Top of Stack) register and on the next entry in the data stack (which is in RAM).
- Another stack stores the return addresses for CALL instructions, and can also be used for temporary data storage.

This stack architecture leads to very compact code. See *Assembly Instruction Set* for a summary of the instruction set.

**Figure 4** shows the layout of a base page, which can be up to 256 bytes long. Each of the chip's processors uses a different base page, whose address is given by the contents of the BP (Base Page) register of that processor. The top of the data stack is in the 8-bit TOS register, and the next element in the data stack is at the location within the base page at the offset given by the contents of the DSP (Data Stack Pointer) register. The assembler shorthand

symbol NEXT refers to the next element in the data stack, which is determined by contents of the location (BP+DSP) in memory, and is thus not an actual processor register.



**Figure 4.** Base-Page Memory Layout

The data stack grows from low memory towards high memory, and is managed through the DSP (Data Stack Pointer) register. Pushing a byte of data onto the data stack involves the following steps:

1. Incrementing the DSP register
2. Storing the current contents of TOS at the address (BP+DSP) in memory
3. Moving the byte of data to TOS

Popping a byte of data from the data stack involves the following steps:

1. Moving TOS to the destination
2. Moving the contents of the address (BP+DSP) in memory to TOS
3. Decrementing the DSP register

The return stack grows from high memory towards low memory, and is managed through the RSP (Return Stack Pointer) register. Calling a subroutine involves the following steps:

1. Storing the high byte of the instruction pointer (IP) register at the address (BP+RSP) in memory
2. Decrementing RSP
3. Storing the low byte of IP at the address (BP+RSP) in memory
4. Decrementing RSP
5. Moving the destination address to the IP register

Similarly, returning from a subroutine involves the following steps:

1. Incrementing RSP
2. Moving the contents of (BP+RSP) to the low byte of the IP register
3. Incrementing RSP
4. Moving the contents of (BP+RSP) to the high byte of IP

The primary programming language used for applications is the Neuron C language, which is a derivative of the ANSI C language that has been optimized and enhanced for LONWORKS distributed control applications. The major enhancements include:

- A network communication model, based on functional blocks and network variables, that simplifies and promotes data sharing between like and disparate devices.
- A network configuration model, based on functional blocks and configuration properties, that facilitates interoperable network configuration tools.
- A type model based on standard and user resource files that expands the market for interoperable devices by simplifying the integration of devices from multiple manufacturers.
- An extensive set of I/O models that support the I/O capabilities of Neuron Chips and Smart Transceivers.
- Powerful event-driven programming extensions, based on **when** statements, that provide easy handling of network, I/O, and timer events.
- A high-level programming model that supports application-specific interrupt handlers and synchronization tools.

See the *Neuron C Programmer's Guide* for more information about the Neuron C programming language. The support for these capabilities is part of the Neuron firmware, and does not need to be written by the programmer.

---

## Multiple Processors

The Neuron core is composed of four independent logical processors:

- Processor 1 is the Media Access Control (MAC) processor
- Processor 2 is the network (NET) processor
- Processor 3 is the application (APP) processor
- Processor 4 is the interrupt (ISR) processor

The interrupt processor is only available for system clock rates of 20 MHz and higher. At the two lower system clock rates, interrupts are handled by the application processor. See *Interrupts* for more information about interrupts.

The processors share a common memory, arithmetic-logic unit (ALU), and control circuitry. Each processor has its own set of registers, as listed in **Table 7**.

**Table 7.** Register Set

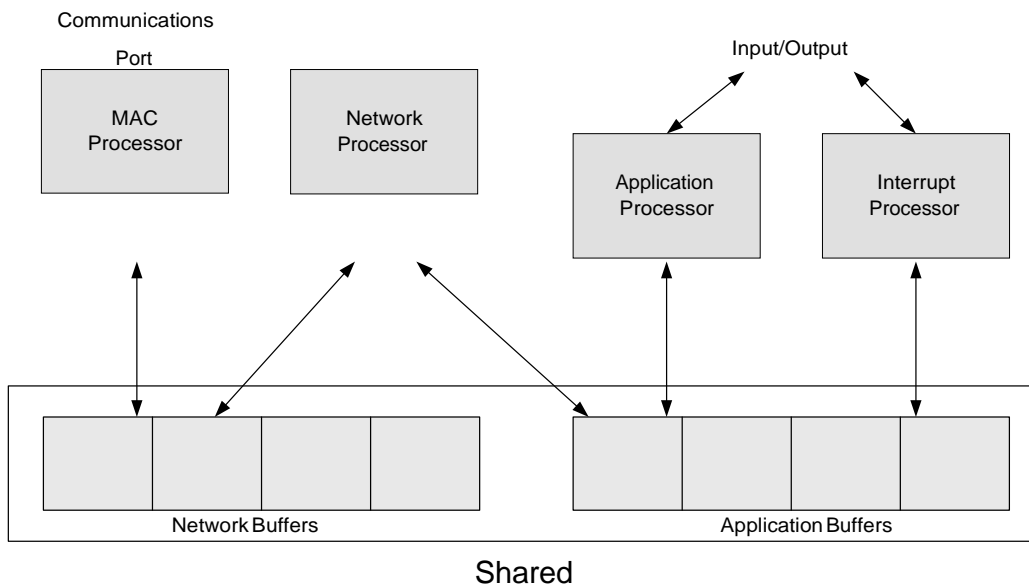
Register	Size (Bits)	Contents
FLAGS	8	Carry Bit and reserved internal flags
IP	16	Next Instruction Pointer

Register	Size (Bits)	Contents
BP	16	Address of 256-Byte Base Page
DSP	8	Data Stack Pointer within Base Page
RSP	8	Return Stack Pointer within Base Page
TOS	8	Top of Data Stack, ALU Input

Processor 1 is the MAC layer processor that handles layers 1 and 2 of the seven-layer LonTalk<sup>®</sup> protocol, which includes driving the communications subsystem hardware and running the media access control algorithm. The MAC processor communicates with the NET processor using network buffers located in shared RAM memory, as shown in **Figure 5**.

Processor 2 is the network processor that implements layers 3 through 6 of the LonTalk protocol. The NET processor handles network variable processing, addressing, transaction processing, authentication, background diagnostics, software timers, network management, and routing functions. The NET processor uses network buffers in shared memory to communicate with the MAC processor, and application buffers to communicate with the APP processor. These buffers are also located in shared memory (RAM). Access to the shared memory is mediated with hardware semaphores to resolve contention when updating shared data.

Processor 3 is the application processor. The APP processor executes the user-written code, together with the system services called by user code.



**Figure 5.** Processor Shared Memory Allocation

---

## Interrupts

The Series 6000 architecture provides hardware support for handling three types of interrupts:

- Lowest priority: application interrupts
- Medium priority: system interrupts
- Highest priority: system-level traps

Application interrupts are asynchronous events related to I/O objects within an application program. An application uses the Neuron C **interrupt()** clause to define the interrupt condition and the interrupt task that handles the condition. The Neuron C program runs the interrupt task whenever the interrupt condition is met. See the *Neuron C Programmer's Guide* for more information about writing interrupt tasks and handling interrupts.

System interrupts are asynchronous system events, such as communications events or SPI UART events. These interrupts are handled by the system firmware.

System-level traps are also system events, generally error conditions. See *Processor Integrity* for more information about these conditions.

For system clock rates of 20 MHz and higher, interrupts are handled by an independent logical processor within the Neuron Core. At the two lower system clock rates, interrupts are handled by the application processor. Thus, at the higher clock rates, an interrupt handler runs in parallel with the application processor, and so does not affect the application processor's registers and stack space. At lower clock rates, an interrupt causes a context switch within the application processor, that is, the interrupt handler saves the processor's registers before it runs and restores them after it completes. Thus, the current instruction always completes prior to servicing a new interrupt. Such context switches also occur within the ISR processor when higher priority interrupts require service.

Thus, when interrupts are processed within the ISR processor, application performance is not degraded, but when interrupts are processed within the APP processor, application performance can be affected because the one processor handles both the application and the interrupts.

---

## Assembly Instruction Set

**Table 8**, **Table 9**, and **Table 10** list the processor instructions, their sizes (in bytes), and their timings (in processor cycles). This information is provided to help you calculate code sizes and execution times.

Most assembly instructions take between one and seven processor cycles (two instructions require 14 cycles). Execution time scales inversely with the system clock rate. The formula for instruction time is:

$$InstructionTime = \frac{(NumberOfCycles \times 3)}{SystemClock}$$

For example, at a system clock rate of 80 MHz, instruction times vary between 37.5 ns and 175 ns.

Programming for a Neuron Chip or Smart Transceiver uses the Neuron C programming language with the IzoT NodeBuilder Development Tool. Additional functions can be written

in the Neuron Assembly language. The Neuron C compiler can optionally produce an assembly listing, and examining this listing can help the programmer to optimize the Neuron C source code. See the *Neuron Assembly Language Reference* for more information about the processor instructions.

**Table 8.** Program Control Instructions

<b>Instruction</b>	<b>Instruction Size (Bytes)</b>	<b>CPU Cycles Required</b>	<b>Description</b>
NOP	1	1	No operation
SBR	1	1	Short unconditional branch Offset: 0 to 15.
BR BRC BRNC	2	2	Branch Branch on carry Branch on not carry Offset: -128 to +127.
SBRZ SBRNZ	1	3	Short branch on TOS zero Short branch on TOS not zero Offset: 0 to 15. Drops TOS.
BRF	3	4	Unconditional branch far
BRZ BRNZ	2	4	Branch on TOS zero Branch on TOS not zero Offset: -128 to +127. Drops TOS.
RET	1	5	Return from subroutine. Drops two bytes from return stack.
BRNEQ	3	4 / 6 (taken / not taken)	Branch if TOS not equal Offset: -128 to +127. Drops TOS if equal.
DBRNZ	2	5	Decrement [RSP] and branch if not zero Offset: -128 to +127. If not taken, drops one byte from return stack.
CALLR	2	5	Call subroutine relative Offset: -128 to +127. Pushes two bytes to return stack.
CALL	2	6	Call subroutine Address in low 8 KB. Pushes two bytes to return stack.



Instruction	Instruction Size (Bytes)	CPU Cycles Required	Description
CALLF	3	7	Call subroutine far Pushes two bytes to return stack.

**Table 9.** Memory and Stack Instructions

Instruction	Instruction Size (Bytes)	CPU Cycles Required	Description
PUSH TOS	1	3	Increment DSP, duplicate TOS into NEXT
DROP TOS	1	3	Move NEXT to TOS, decrement DSP
DROP_R TOS	1	6	Move NEXT to TOS, decrement DSP, return from call
PUSH NEXT PUSH DSP PUSH RSP PUSH FLAGS	1	4	Push processor register
POP NEXT POP DSP POP RSP POP FLAGS	1	4	Pop processor register
DROP NEXT	1	2	Decrement DSP
DROP_R NEXT	1	5	Decrement DSP and return from call
PUSH !D POP !D	1	4	Push / pop byte register [8 to 23]
PUSH !TOS	1	4	Push TOS EA = BP + TOS, push byte to NEXT.
POP !TOS	1	4	Pop TOS EA = BP + TOS, pop byte from NEXT.
PUSH [RSP]	1	4	Push from return stack to data stack, RSP unchanged
DROP [RSP]	1	2	Increment RSP
PUSHS #literal	1	4	Push short literal value [0 to 7]

Instruction	Instruction Size (Bytes)	CPU Cycles Required	Description
PUSH #literal	2	4	Push 8-bit literal value [0 to 255]
PUSHPOP	1	5	Pop from return stack, push to data stack
POPPUSH	1	5	Pop from data stack, push to return stack
PUSH [DSP][-D] POP [DSP][-D]	1	5	Push / pop DSP modified by D EA = BP + DSP – displacement [1 to 8]
PUSHD #literal	3	6	Push 16-bit literal value, high byte first
PUSHD [PTR]	1	6	Push from 16-bit pointer [0 to 3], high byte first
POPD [PTR]	1	6	Pop to 16-bit pointer [0 to 3], low byte first
PUSH [PTR][TOS] POP [PTR][TOS]	1	6	Push / pop 16-bit pointer [0 to 3], modified by TOS EA = (16-bit pointer) + TOS.
PUSH [PTR][D] POP [PTR][D]	2	7	Push / pop 16-bit pointer [0 to 3], modified by D EA = (16-bit pointer) + displacement [0 to 255]
PUSH absolute POP absolute	3	7	Push / pop absolute memory address
<b>Note:</b> EA = Effective Address.			

**Table 10.** Arithmetic and Logic Instructions

Instruction	Instruction Size (Bytes)	CPU Cycles Required	Description
INC DEC NOT	1	2	Increment TOS Decrement TOS Negate TOS
ROL ROR	1	2	Rotate left TOS through carry Rotate right TOS through carry
SHL SHR	1	2	Unsigned left shift TOS, clear carry Unsigned right shift TOS, clear carry

Instruction	Instruction Size (Bytes)	CPU Cycles Required	Description
SHLA SHRA	1	2	Signed left shift TOS into carry Signed right shift TOS into carry
ADD AND OR XOR ADC	1	4	Operate with NEXT on TOS, drop NEXT
ADD #literal AND #literal OR #literal XOR #literal	2	3	Operate with literal on TOS
ADD_R AND_R OR_R XOR_R	1	7	Operate with NEXT on TOS, drop NEXT and return
ALLOC #literal	1	3	Add [1 to 8] to data stack pointer
DEALLOC_R #literal	1	6	Subtract [1 to 8] from data stack pointer and return
SUB NEXT,TOS	1	4	TOS = NEXT – TOS, drop NEXT
SBC NEXT, TOS	1	4	TOS = NEXT – TOS – carry, drop NEXT
SUB TOS,NEXT	1	4	TOS = TOS – NEXT, drop NEXT
XCH	1	4	Exchange TOS and NEXT
INC [PTR]	1	6	Increment 16-bit pointer [0 to 3]
DIV	1	14	Divide NEXT by TOS, quotient is in TOS, remainder is in NEXT
MUL	1	14	Multiply NEXT * TOS, result is in TOS, NEXT

---

## Memory Architecture

The memory architecture for a Series 6000 chip includes on-chip memory and off-chip non-volatile memory. Every Series 6000 device must have at least 512 KB of off-chip memory available in an SP1 flash device.

---

## On-Chip Memory

A Series 6000 chip has the following on-chip memory:

- 16 KB of read-only memory (ROM)

The ROM holds an initial system image that is used only to bootstrap the system from flash or to initially load the flash over the network during manufacturing of a Series 6000 device. Please see *Device Programming for further details*.

- 64 KB of random access memory (RAM)

The RAM provides memory for user applications and data, stack segments for each processor, and network and application buffers. The RAM is partitioned according to a logical memory map, as described in *Memory Map*.

A Series 6000 chip contains no internal writable non-volatile memory (such as EEPROM memory) for application use. However, each Series 6000 chip does contain a unique IEEE MAC ID in non-volatile read-only memory.

The chip's memory management block allows the RAM to emulate both ROM and NVM by ensuring that changes to the RAM are shadowed to external NVM at appropriate intervals. All writes that are intended for NVM are written to the RAM, and then are shadowed to the NVM. Thus, the chip's internal processors access the RAM only; they do not directly access either the ROM or external NVM.

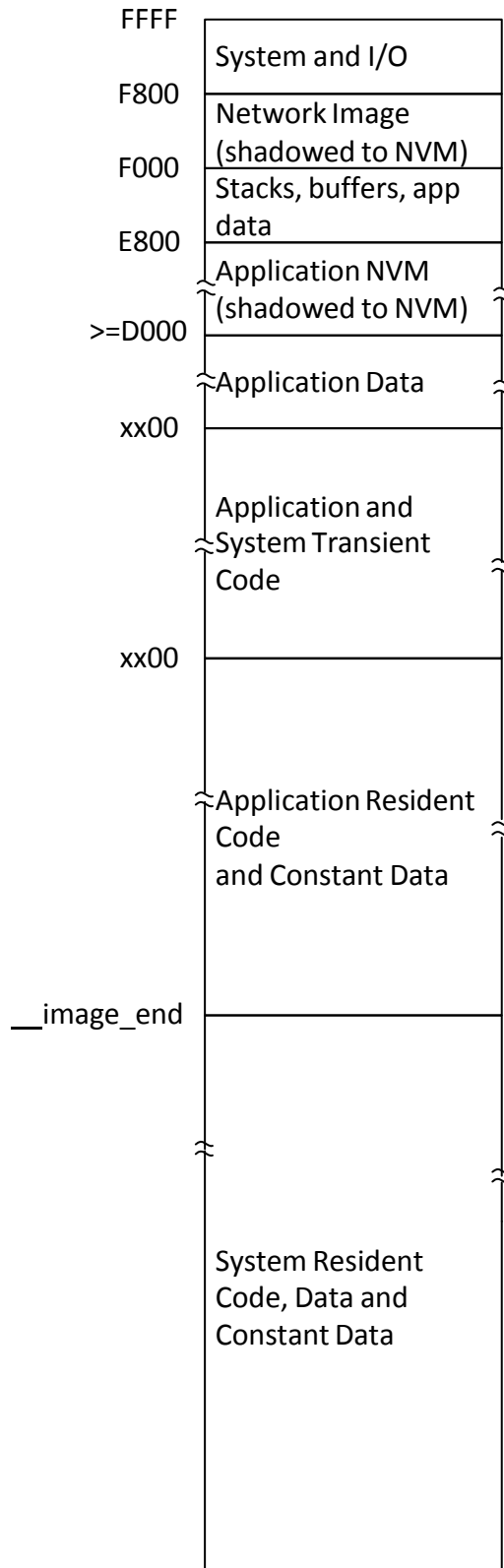
The state of the RAM is retained as long as power is applied to the device. After a device reset, the initialization sequence copies the contents of the ROM and relevant NVM data to the RAM.

---

## Memory Map

A Neuron C application has a memory map of 64 KB. **Figure 6** shows the memory map for a Series 6000 chip. The memory map is a logical view of device memory, rather than a physical view, because the Series 6000 chip's processors only directly access RAM.

The memory map for a Series 6000 chip is "auto-tuned". That is, the linker decides how to partition the RAM based on the needs placed upon it by the application. The user does not specify the address ranges used for each type of memory (code vs data vs persistent data).



**Figure 6.** Series 6000 Chip Memory Map

The memory map divides the Series 6000 chip’s physical RAM into the following types of logical memory:

- System Image (0x0000 to image\_end (system image dependent)) — This area is initially a copy of the system firmware image from the physical ROM but this is overwritten with a system image from flash later in the boot process. This area is write-protected so that an application cannot alter the system firmware.
- Application Resident Code/Data (from image\_end+1 up to a variable address) — The size of this area is determined at application link time.
- Transient Code – The size of this area is determined at application link time. By default, most code in an application is “transient” which means it is brought into this area from flash on demand. There is some system image transient code as well that shares this area.
- Application NVM – The size of this area is determined at application link time. The maximum size of this area is 6KB. This area is brought in from flash at boot time and written back to flash as it is modified.
- System RAM (2 KB at addresses 0xE800 to 0xEFFF) — This area holds system data, stack segments, buffers and select application data.
- Mandatory NVM (2 KB at addresses 0xF000 to 0xF7FF) — This area is shadowed from the mandatory 2 KB of NVM, and holds device configuration data.
- Reserved memory (2 KB at addresses 0xF800 to 0xFFFF) — This area is reserved for system use.

---

## External Serial Memory Interface

The interface for accessing off-chip non-volatile memory (NVM) is a serial interface that uses the serial peripheral interface (SPI).

## Serial Peripheral Interface (SPI)

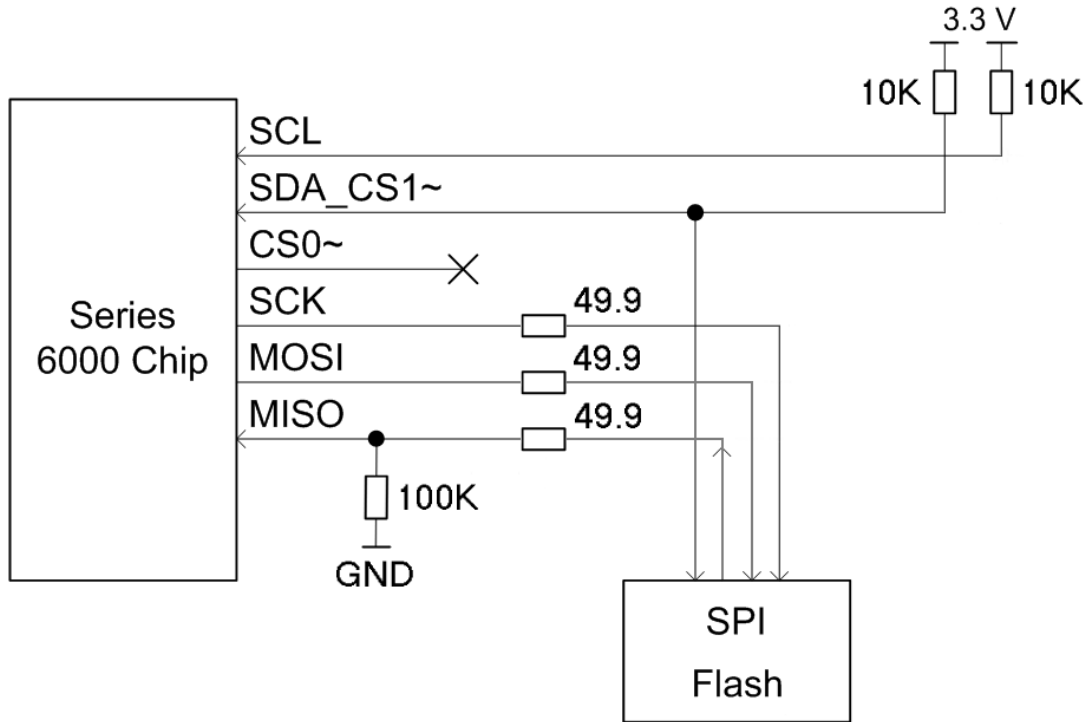
The serial peripheral interface (SPI) protocol for the Series 6000 chip uses the pins listed in table 11 and shown in Figure 7.

**Table 11.** Memory Interface Pins for the SPI Protocol

Pin Number	Pin Name	Direction	Description
Pin 40	CS0~	Output	First slave-select (SS) signal
Pin 43	SDA_CS1~	Bidirectional	Second slave-select (SS) signal
Pin 46	MISO	Input	Master Input, Slave Output (MISO) signal
Pin 47	SCK	Output	Serial clock (SCK) signal
Pin 48	MOSI	Output	Master Output, Slave Input (MOSI) signal
<b>Note:</b> Signal direction is from the point of view of the Series 6000 chip.			

These pins are 3.3 V pins, and are 5 V tolerant.

A Series 6000 chip is always the master SPI device; any external NVM devices are always slave devices. Multimaster configurations are not supported.



**Figure 7.** SPI Memory Interface

Series 6000 devices support the 3-byte addressing mode for SPI flash devices.

The SPI protocol defines four modes of operation; each mode specifies different behavior for flow control on the data bus with respect to the clock signal polarity (CPOL) and phase (CPHA). A Series 6000 device uses SPI Mode 0: CPOL is 0, CPHA is 0, and the SCK line is idle low. For this mode, the Series 6000 chip latches in data on the rising edge of the SCK line, and is output on the falling edge of the SCK line. Note that the 49.9 Ohm and 100k Ohm resistors shown in the figure are generally not needed, and can be omitted.

A Series 6000 chip runs the SPI protocol from the serial memory interface at 20 MHz for reads and 2.5 MHz for writes.

## Non-Volatile Memory Integrity

The areas labeled Network Image and Application NVM (see **Figure 6.** Series 6000 Chip Memory Map) are written out to flash in an all or nothing fashion. This is accomplished by having multiple copies of the data, an active and a standby. When updating, the standby is updated and only once that is completed does it become active. Therefore, when changing NVM from state X to state Y, were a power cycle to occur during the process, you will either end up in state X or state Y, but not some intermediate (corrupted) version.

The maximum allowed size of this area is 8KB. This means that the typical application non-volatile data will be limited to somewhere in the range of 6 to 7KB depending on other uses

of this area (e.g., network configuration tables). This area comprises either 2 or 4 flash sectors of 4KB each depending on the demands of the application. For the 2 sector case, this area can be modified at most 200,000 times over the device's lifetime. This works out to about one update per hour over a 20-year lifetime.

Note that the data is committed to flash using a 500 millisecond hold down timer. So, if you make multiple modifications to NVM in quick succession, it will typically only result in one erase/write cycle. Note that if you make modifications to NVM and then do a controlled reset before the timer expires, the data is written immediately prior to the reset.

## Device Support

A Series 6000 device requires 512KB or greater flash devices that meet the requirements as described below. Furthermore, the flash device must use 4KB sectors and be capable of write-protecting the lower half of the address space.

Larger flash sizes are supported and allow for larger system images and larger application code, data and logs. Series 6000 chips have no user-accessible on-chip ROM or non-volatile writable memory. A default system image is contained in on-chip ROM, but its sole purpose is to support the downloading of the system image over the network in a factory or lab setting. Flash memory for use with Series 6000 chips must support the following features:

- SPI serial interface, minimum clock rate of 20 MHz
- 24-bit addressing
- At least 4 Mb capacity
- 3.3VCC operation with a minimum 2.7 VCC
- Operating temperature range of -40 °C to +85 °C
- >100,000 erase cycles, 20 year retention data
- Status register with BUSY flag at D0
- 4 KB erasable sector size
- 256-byte page write architecture (up to 256 bytes written inside a single ~CS assertion)
- Block write-protection capability via Status Register write, at least 4 block protect bits, with capability of protecting first half of the device
- Block write protect setting using these bits: 0bxx1011xx (4 Mb), 0bxx1100xx (8 Mb), 0bxx1101xx (16 Mb), 0bxx1110xx (32 Mb)
- JEDEC ID reporting, including device capacity in the 3<sup>rd</sup> byte
- Identical command set for all implemented commands listed below:

Command	Value
Write Enable	06h
Read Status Reg	05h
Write Status Reg	01h
Read Data	03h
Page Program (write)	02h
4KB Sector Erase	20h
Chip Erase	C7h
JEDEC ID	9Fh

Echelon has qualified the following SPI flash memory devices for use with a Series 6000 device:

- Winbond W25X40CL 4 M-bit 2.3 V minimum SPI serial flash memory
- Winbond W25Q80BV 8 M-bit 2.7 V minimum SPI serial flash memory



- ON Semiconductor LE25U40CMC 4 M-bit 2.3V minimum SPI serial flash memory
- Micron M25PX80 8 M-bit 2.3V minimum SPI serial flash memory
- Macronix MX25L8035E 8 M-bit 2.7V minimum SPI serial flash memory
- Adesto AT25SF041 4 M-bit 2.5V minimum SPI serial flash memory
- Adesto AT25SF081 8 M-bit 2.5V minimum SPI serial flash memory

## Device Programming

When building a custom device, the bootloader and system image need to be loaded using a PROM programmer or using a I2C/SPI Host Adaptor such as the Aardvark tool available from Total Phase. These images can also be loaded over the network in certain cases.

In the following instructions <LonWorks> is typically “C:\Program Files (x86)\LonWorks” and <part> is “6010” for a Neuron 6010 or FT 6010 Smart Transceiver and “6050” for a Neuron 6050 Processor or FT 6050 Smart Transceiver. For use with a programmer, the combined bootloader and system image can be found at:

```
<LonWorks>\images\ver21\b<part>v4.hex
```

For the Neuron 6050 Processor and FT 6050 Transceiver you can load images over the network. In order to do this, use NodeLoad with the -Q or -W with the following image:

```
<LonWorks>\images\ver21\bl<part>v4.ndl
```

Network loading can only be done if the default 78kbps communications parameters and transceiver type match that of the network interface or IzoT Router in use.

**Note:** You cannot do network loading using the FT 6010 Smart Transceiver.

After the NVM has been programmed initially, the application image or a revised system image can be loaded over the network using NodeUtil, NodeLoad or any OpenLNS based tool such as the IzoT Commissioning Tool.

When a revised system image is loaded to a device with NodeUtil or NodeLoad, the bootloader should also be updated.

The revised system image file can be found at:

```
<LonWorks>\images\ver21\b<part>v4.ndl
```

The bootloader file for use with all Series 6000 parts can be found at:

```
<LonWorks>\images\ver21\bla6000.ndl
```

An application image may also be loaded using a universal programmer or SPI programming device. The application image for programmer use contains the extension “.NMF”. This image contains the bootloader, system image and application image.

When using the Aardvark I2C/SPI Host Adapter with the Flash Center Memory Programmer software to load your application NMF file, you must use a byte padding value of “00” (the default padding value used by the Aardvark I2C/SPI Host Adapter is “FF”). Furthermore, Total Phase programmers require that the file name end in “.HEX” in order to properly read the programming file so you will need to add a .HEX extension to your NMF file.

## Recovering a Device

If it should become necessary to recover a Series 6000 chip, perform the following tasks:

1. Make sure the Service Pin button is not depressed.
2. Press and hold the device's Reset button. If the device does not have a Reset button, connect the **RST~** pin (pin 28) of the Series 6000 chip to GND to hold the chip in the reset state.
3. Press and hold the Service Pin button.
4. Release the device's Reset button (or remove the GND connection from the Series 6000 chip's **RST~** pin).
5. Wait for at least 10 seconds.
6. Release the Service Pin button.
7. The device will become "applicationless".

At this point, you can reload the device with whatever application is required (for example, a Neuron C application or a ShortStack Micro Server).

---

## *Transience*

Transient code is either system image code or application code that is read in from flash only when it is needed. By using this strategy, much larger applications than would be allowed by the internal RAM alone can be supported. The application program controls which of its functions are "resident" (always in RAM) vs. "transient" (must be brought in from flash on demand). Resident functions reduce the space available in the RAM for transient functions.

The linker imposes certain minimums on the transient area based on the number of transient function and their sizes.

Functions that execute within interrupts must be resident.

---

## *Data Logging*

A data logging mechanism is provided which allows the application to store logs into external flash. These logs are circular and the number of entries and size of each entry are user definable. The logs are power fail safe (that is, a power failure during a write of entry N either produces a log with N or N-1 entries but does not corrupt entries). APIs exist to both read and write entries. The number of writes that can occur to a log depend completely on the log parameters. In terms of an example, think about a log that is 32KB with 128-byte entries. This works out to about 256 entries. With 4KB flash sectors, this means one sector erase for every 32 entries. Since there are 8 sectors in a 32KB log and each sector can be erased 100,000 times, you have a total of  $8 \times 100,000 \times 32$  (or 25.6 million) log entry writes possible. This works out to one log update every 30 seconds over a 20-year lifetime. Higher frequency writes can be achieved by increasing the size of the log or decreasing the size of each entry.

---

## *Boot Loader*

In addition to a system image, application, network image and logs, the flash contains a boot loader. The boot loader is responsible for choosing a system image and application to run at boot time and conveying essential information about this to the system image loaded into RAM. The system image and application and the boot loader itself can be updated over the network. During the update of the system image and boot loader, the active version continues to run and the node is only interrupted during the switchover.

The first half of the flash memory is write-protected. This protects against accidental writes to the boot loader, system image, or application that would have the potential to cause a hard

failure in the device. The write-protected part of the flash contains the bootloader, active system image, and active application.

---

## JTAG Interface

All Series 6000 chips provide an interface for the Institute of Electrical and Electronics Engineers (IEEE) Standard Test Access Port and Boundary-Scan Architecture (IEEE 1149.1-1990) of the Joint Test Action Group (JTAG) to allow a Series 6000 chip to be included in the boundary-scan chain for device production tests.

You can obtain a Boundary Scan Description Language (BSDL) file from the Echelon Web site:

- [www.echelon.com/products/neuron/](http://www.echelon.com/products/neuron/) for a Neuron 6000 Processor
- <http://www.echelon.com/products/components/ic/ft5000/default.htm> for an FT 6000 Smart Transceiver

The JTAG interface for Series 6000 chips can operate at up to 5 MHz. The JTAG interface includes the following pins:

- **TDI** — Test Data In (pin 21)  
Used to shift in serial test instructions and data. Connect this pin to the TDI signal of a JTAG connector or to the TDO signal of an upstream device in a JTAG chain.
- **TDO** — Test Data Out (pin 22)  
Used to shift out serial test instructions and data. When **TDO** is not being driven by the internal circuitry, the pin is in a high impedance state. Connect this pin to the TDO signal of a JTAG connector or to the TDI signal of a downstream device in a JTAG chain.
- **TCK** — Test Clock (pin 19)  
Provides the clock to run the test access port (TAP) controller state machine, which controls the JTAG data and instruction registers. You can stop the **TCK** signal in either the high or low state, and you can set the clock frequency up to 5 MHz. The **TCK** pin supports hysteresis; the typical hysteresis is approximately 300 mV.
- **TMS** — Test Mode Select (pin 20)  
Controls test operations of the TAP controller. On the falling edge of the **TCK** signal, depending on the state of the **TMS** signal, the TAP controller state machine changes state.
- **TRST~** — Test Reset (pin 17)  
Resets the TAP controller state machine.

These pins comply with the JTAG standard protocol (IEEE 1149.1) for boundary scan operations, and can be used with industry-standard JTAG tools. Each of these pins also includes an internal pull-up resistor, as recommended by the JTAG standard. These pull-ups are only strong enough to pull the input up when the pin is floating, but not strong enough for an external load.

The JTAG interface for Series 6000 chips supports the following JTAG instructions (see the device BSDL file for instruction register codes):

- **BYPASS** — bypasses the current device (to allow connection to another device in the chain)  
Required by the IEEE 1149.1 standard
- **SAMPLE/PRELOAD** — samples current values, or preloads known values into the boundary-scan cells for a follow-on operation  
Required by the IEEE 1149.1 standard

- EXTEST — tests the interconnection between two devices  
Required by the IEEE 1149.1 standard
- HIGHZ — sets all digital outputs of the Series 6000 chip to a disabled (high-impedance) state
- IDCODE — returns the Device ID for the chip

The Device ID for an FT 6000 Smart Transceiver is 0x1320062F; the Device ID for a Neuron 6000 Processor is 0x1320162F.

For more information about the JTAG standard, see *IEEE Standard Test Access Port and Boundary-Scan Architecture*, IEEE Std 1149.1-1990 (includes IEEE Std 1149.1a-1993) and *Supplement to IEEE Std 1149.1-1990, IEEE Standard Test Access Port and Boundary-Scan Architecture*, IEEE Std 1149.1b-1994. These documents are available from the IEEE: [www.ieee.org/web/standards/home/index.html](http://www.ieee.org/web/standards/home/index.html).

## Operating Conditions

**Table 12** describes the standard operating conditions for Series 6000 chips. In the table, all values apply to both the FT 6000 Smart Transceiver and the Neuron 6000 Processor, except the value for  $I_{DD3-TX}$ , which applies to the FT 6000 Smart Transceiver only. For a Neuron 6000 Processor, see the specifications for your specific transceiver for transmit current consumption.

**Table 12.** Series 6000 Chip Operating Conditions

Parameter <sup>1</sup>	Description	Minimum	Typical	Maximum
$V_{DD3}$	Supply voltage	3.0 V	3.3 V	3.6 V
$T_A$	Ambient temperature	-40 °C		+85 °C
$f_{XIN}$	XIN clock frequency <sup>2</sup>		10.0000 MHz	
$I_{DD3-RX}$	Current consumption in receive mode for given system clock rates <sup>3</sup>  5 MHz 10 MHz 20 MHz 40 MHz 80 MHz		9 mA 9 mA 15 mA 23 mA 38 mA	15 mA 15 mA 23 mA 33 mA 52 mA
$I_{DD3-TX}$	Current consumption in transmit mode <sup>3, 4</sup>		$I_{DD3-RX} + 15$ mA	$I_{DD3-RX} + 18$ mA

### Notes for Table 12:

1. All parameters assume nominal supply voltage ( $V_{DD3} = 3.3$  V) and operating temperature ( $T_A$  between -40 °C and +85 °C), unless otherwise noted.
2. See *Clock Requirements* for more detailed information about the XIN clock frequency.

- Assumes no load on digital I/O pins, and that the I/O lines are not switching.

To calculate the  $I_{DD3}$  current for each switching output, use the following formula:

$$I_{DD3\_pin} = ((12 \times 10^{-12}) + C_{L\_pin}) \times V_S \times f_{pin}$$

where  $12 \times 10^{-12}$  is the effective on-chip capacitance,  $C_{L\_pin}$  is the load capacitance of the I/O pin,  $V_S$  is the supply voltage, and  $f_{pin}$  is the frequency at which the pin switches.

For example, a pin with 27 pF external load switching at 1 MHz would have a total switching current of  $I_{DD3} = (12\text{pF} + 27\text{pF}) * 3.6\text{V} * 10^6\text{Hz} = 140 \mu\text{A}$ .

To calculate the total  $I_{DD3}$  current, sum the  $I_{DD3}$  calculations for each pin:

$$I_{DD3\_total} = \sum_1^N I_{DD3\_pin\_N}$$

Any DC loads, such as LEDs or resistors, should also be added.

- Current consumption in transmit mode represents a peak value rather than a continuous usage value because a Series 6000 device does not typically transmit data continuously.

**Table 13** describes the absolute maximum conditions for Series 6000 chips. Absolute maximum ratings are limits beyond which the device might become damaged or have its useful life impaired. Functional operation under these conditions is not implied.

**Table 13.** Series 6000 Chip Absolute Maximum Ratings

Parameter	Description	Minimum	Maximum
$V_{DD3}$	Supply voltage	-0.3 V	+3.7 V
$V_{i\text{-digitalIn}}$	Input voltage – digital I/O pins	-0.3 V	+5.5 V
$V_{i\text{-digitalOut}}$	Output voltage – digital I/O pins	-0.3 V	$V_{DD3} + 0.3 \text{ V}$
$V_{i\text{-other}}$	Input voltage – other non-power pins	-0.3 V	$V_{DD3} + 0.3 \text{ V}$
$I_i$	Input current – all non-power pins	-10 mA	+10 mA
$T_{\text{storage}}$	Storage temperature	-55 °C	+125 °C

All input and output pins can withstand 100 mA forced into or out of the pin without latch-up. See *Avoidance of Damaging Conditions* for more information about latch-up.

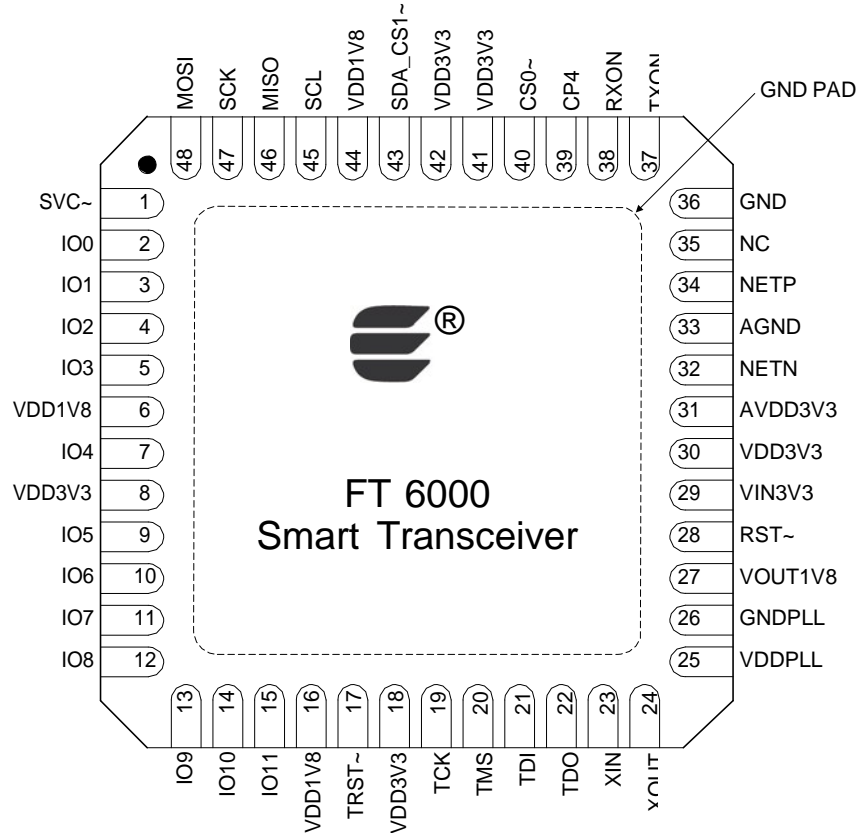
## Pin Assignments

Although the pin assignments for the Neuron 6000 Processor and the FT 6000 Smart Transceiver are very similar, there are a few differences, as described in the following sections.

All pins can withstand 2 kV Electrostatic Discharge (ESD) voltage, as tested according to MIL-STD-883 Method 3015.7.

## FT 6000 Smart Transceiver

**Figure 8** shows the pinout for the FT 6000 Smart Transceiver. The central rectangle in the figure represents the bottom pad (pin 49), which must be connected to ground.



**Figure 8.** FT 6000 Smart Transceiver Chip Pinout Diagram

**Table 14** lists the pin assignments for the FT 6000 Smart Transceiver. All digital inputs are low-voltage transistor-transistor logic (LVTTTL) compatible, 5 V tolerant, with low leakage. All digital outputs are slew-rate limited to reduce Electromagnetic Interference (EMI) concerns.

**Table 14.** FT 6000 Smart Transceiver Pin Assignments

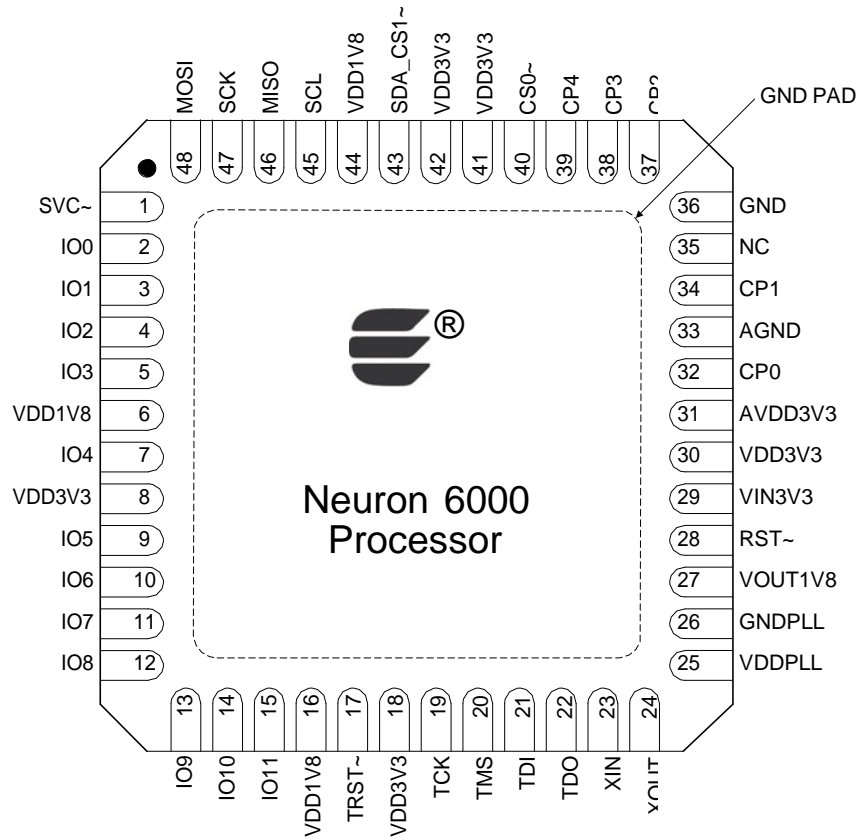
<b>Name</b>	<b>Pin Number</b>	<b>Type</b>	<b>Description</b>
SVC~	1	Digital I/O	Service (active low)
IO0	2	Digital I/O	IO0 for I/O Objects
IO1	3	Digital I/O	IO1 for I/O Objects
IO2	4	Digital I/O	IO2 for I/O Objects
IO3	5	Digital I/O	IO3 for I/O Objects
VDD1V8	6	Power	1.8 V Power Input (from internal voltage regulator)
IO4	7	Digital I/O	IO4 for I/O Objects
VDD3V3	8	Power	3.3 V Power
IO5	9	Digital I/O	IO5 for I/O Objects
IO6	10	Digital I/O	IO6 for I/O Objects
IO7	11	Digital I/O	IO7 for I/O Objects
IO8	12	Digital I/O	IO8 for I/O Objects
IO9	13	Digital I/O	IO9 for I/O Objects
IO10	14	Digital I/O	IO10 for I/O Objects
IO11	15	Digital I/O	IO11 for I/O Objects
VDD1V8	16	Power	1.8 V Power Input (from internal voltage regulator)
TRST~	17	Digital Input	JTAG Test Reset (active low)
VDD3V3	18	Power	3.3 V Power
TCK	19	Digital Input	JTAG Test Clock
TMS	20	Digital Input	JTAG Test Mode Select
TDI	21	Digital Input	JTAG Test Data In
TDO	22	Digital Output	JTAG Test Data Out
XIN	23	Oscillator In	Crystal oscillator input
XOUT	24	Oscillator Out	Crystal oscillator output
VDDPLL	25	Power	1.8 V Power Input (from internal voltage regulator)
GNDPLL	26	Power	Ground
VOU1V8	27	Power	1.8 V Power Output (of internal voltage regulator)
RST~	28	Digital I/O	Reset (active low)

Name	Pin Number	Type	Description
VIN3V3	29	Power	3.3 V input to internal voltage regulator
VDD3V3	30	Power	3.3 V Power
AVDD3V3	31	Power	3.3 V Power
NETN	32	Comm	Network Port (polarity insensitive)
AGND	33	Ground	Ground
NETP	34	Comm	Network Port (polarity insensitive)
NC	35	N/A	Do Not Connect
GND	36	Ground	Ground
TXON	37	Digital I/O	TxActive for optional network activity LED
RXON	38	Digital I/O	RxActive for optional network activity LED
CP4	39	Digital I/O	Connect to $V_{DD33}$ through a 4.99 k $\Omega$ pullup resistor
CS0~	40	Digital I/O for Memory	SPI slave select 0 (active low)
VDD3V3	41	Power	3.3 V Power
VDD3V3	42	Power	3.3 V Power
SDA_CS1~	43	Digital I/O for Memory	I <sup>2</sup> C: serial data SPI: slave select 1 (active low)
VDD1V8	44	Power	1.8 V Power Input (from internal voltage regulator)
SCL	45	Digital I/O for Memory	I <sup>2</sup> C serial clock
MISO	46	Digital I/O for Memory	SPI master input, slave output (MISO)
SCK	47	Digital I/O for Memory	SPI serial clock
MOSI	48	Digital I/O for Memory	SPI master output, slave input (MOSI)
PAD	49	Ground Pad	Ground

## Neuron 6000 Processor

**Figure 9** shows the pinout for the Neuron 6000 Processor. The central rectangle in the figure represents the bottom pad (pin 49), which must be connected to ground.





**Figure 9.** Neuron 6000 Processor Pinout Diagram

**Table 15** lists the pin assignments for the Neuron 6000 Processor. All digital inputs are low-voltage transistor-transistor logic (LVTTL) compatible, 5 V tolerant, with low leakage. All digital outputs are slew-rate limited to reduce Electromagnetic Interference (EMI) concerns.

**Table 15.** Neuron 6000 Processor Pin Assignments

Name	Pin Number	Type	Description
SVC~	1	Digital I/O	Service (active low)
IO0	2	Digital I/O	IO0 for I/O Objects
IO1	3	Digital I/O	IO1 for I/O Objects
IO2	4	Digital I/O	IO2 for I/O Objects
IO3	5	Digital I/O	IO3 for I/O Objects
VDD1V8	6	Power	1.8 V Power Input (from internal voltage regulator)
IO4	7	Digital I/O	IO4 for I/O Objects
VDD3V3	8	Power	3.3 V Power
IO5	9	Digital I/O	IO5 for I/O Objects

Name	Pin Number	Type	Description
IO6	10	Digital I/O	IO6 for I/O Objects
IO7	11	Digital I/O	IO7 for I/O Objects
IO8	12	Digital I/O	IO8 for I/O Objects
IO9	13	Digital I/O	IO9 for I/O Objects
IO10	14	Digital I/O	IO10 for I/O Objects
IO11	15	Digital I/O	IO11 for I/O Objects
VDD1V8	16	Power	1.8 V Power Input (from internal voltage regulator)
TRST~	17	Digital Input	JTAG Test Reset (active low)
VDD3V3	18	Power	3.3 V Power
TCK	19	Digital Input	JTAG Test Clock
TMS	20	Digital Input	JTAG Test Mode Select
TDI	21	Digital Input	JTAG Test Data In
TDO	22	Digital Output	JTAG Test Data Out
XIN	23	Oscillator In	Crystal oscillator input
XOUT	24	Oscillator Out	Crystal oscillator output
VDDPLL	25	Power	1.8 V Power Input (from internal voltage regulator)
GNDPLL	26	Power	Ground
VOUT1V8	27	Power	1.8 V Power Output (of internal voltage regulator)
RST~	28	Digital I/O	Reset (active low)
VIN3V3	29	Power	3.3 V Power Input
VDD3V3	30	Power	3.3 V Power
AVDD3V3	31	Power	3.3 V Power
CP0	32	Comm	Single-Ended Mode: Receive serial data Special-Purpose Mode: Receive serial data
AGND	33	Ground	Ground
CP1	34	Comm	Single-Ended Mode: Transmit serial data Special-Purpose Mode: Transmit serial data
NC	35	N/A	Do Not Connect
GND	36	Ground	Ground
CP2	37	Comm	Single-Ended Mode: External transceiver enable Special-Purpose Mode: Bit clock

Name	Pin Number	Type	Description
CP3	38	Comm	Do Not Connect
CP4	39	Comm	Single-Ended Mode: Collision detect Special-Purpose Mode: Frame clock
CS0~	40	Digital I/O for Memory	SPI slave select 0 (active low)
VDD3V3	41	Power	3.3 V Power
VDD3V3	42	Power	3.3 V Power
SDA_CS1~	43	Digital I/O for Memory	I <sup>2</sup> C: serial data SPI: slave select 1 (active low)
VDD1V8	44	Power	1.8 V Power Input (from internal voltage regulator)
SCL	45	Digital I/O for Memory	I <sup>2</sup> C serial clock
MISO	46	Digital I/O for Memory	SPI master input, slave output (MISO)
SCK	47	Digital I/O for Memory	SPI serial clock
MOSI	48	Digital I/O for Memory	SPI master output, slave input (MOSI)
PAD	49	Ground Pad	Ground

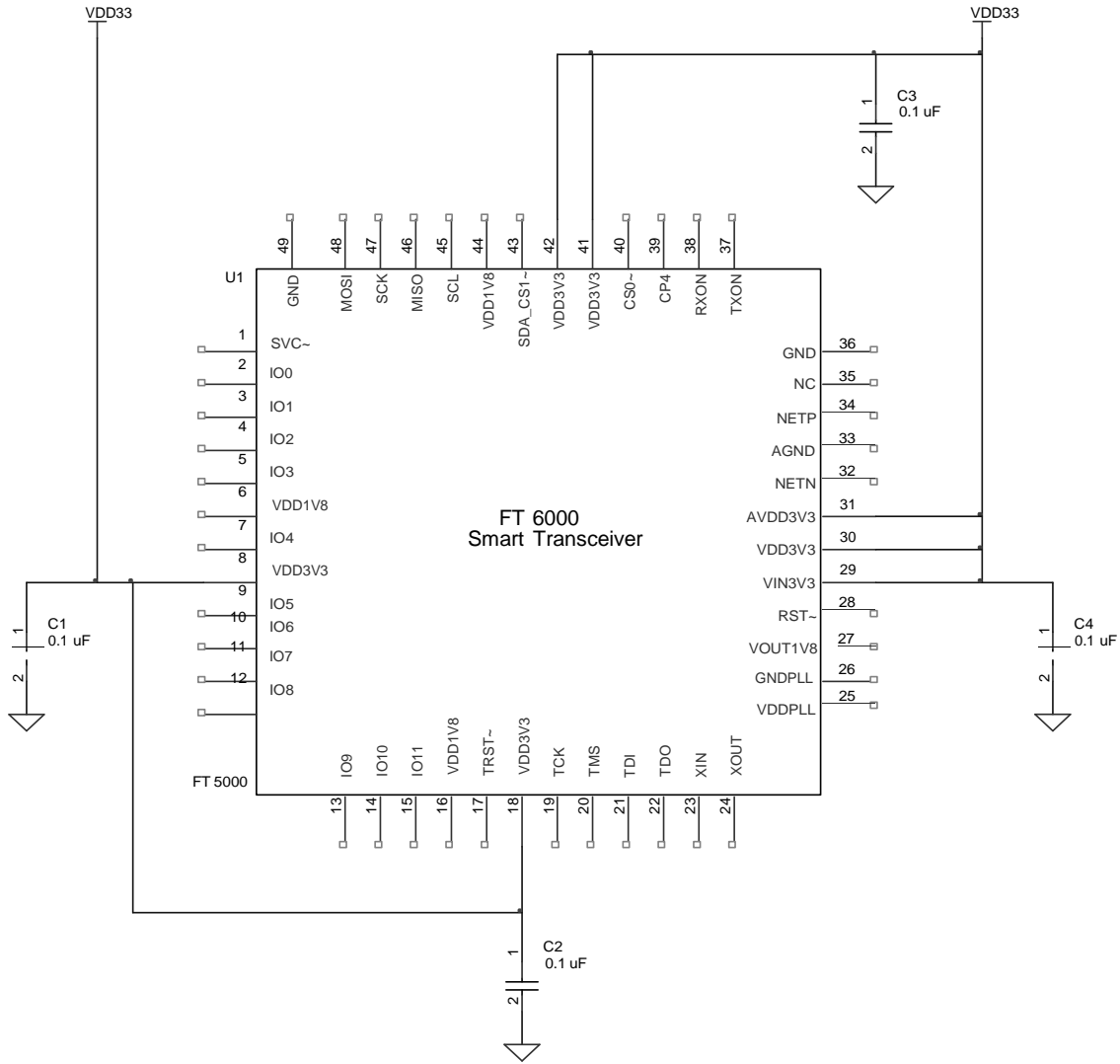
---

## Pin Connections

This section describes the electrical connections for the various pins on a Series 6000 chip. Unless specified otherwise, the connections apply to both the FT 6000 Smart Transceiver and the Neuron 6000 Processor.

See Appendix E, *Example Schematic*, for a more complete example schematic for an FT 6000 Smart Transceiver.

Connect the **VDD3V3** pins (8, 18, 29, 30, 41, and 42) to  $V_{DD33}$ . Also connect the **AVDD3V3** pin (31) to an analog  $V_{DD33}$  source, if different from the digital  $V_{DD33}$  source. In general, the **VDD3V3** pins and the **AVDD3V3** pin connect to the same  $V_{DD33}$  source. In addition, connect decoupling capacitors to the **VDD3V3** pins, as shown in **Figure 10**.



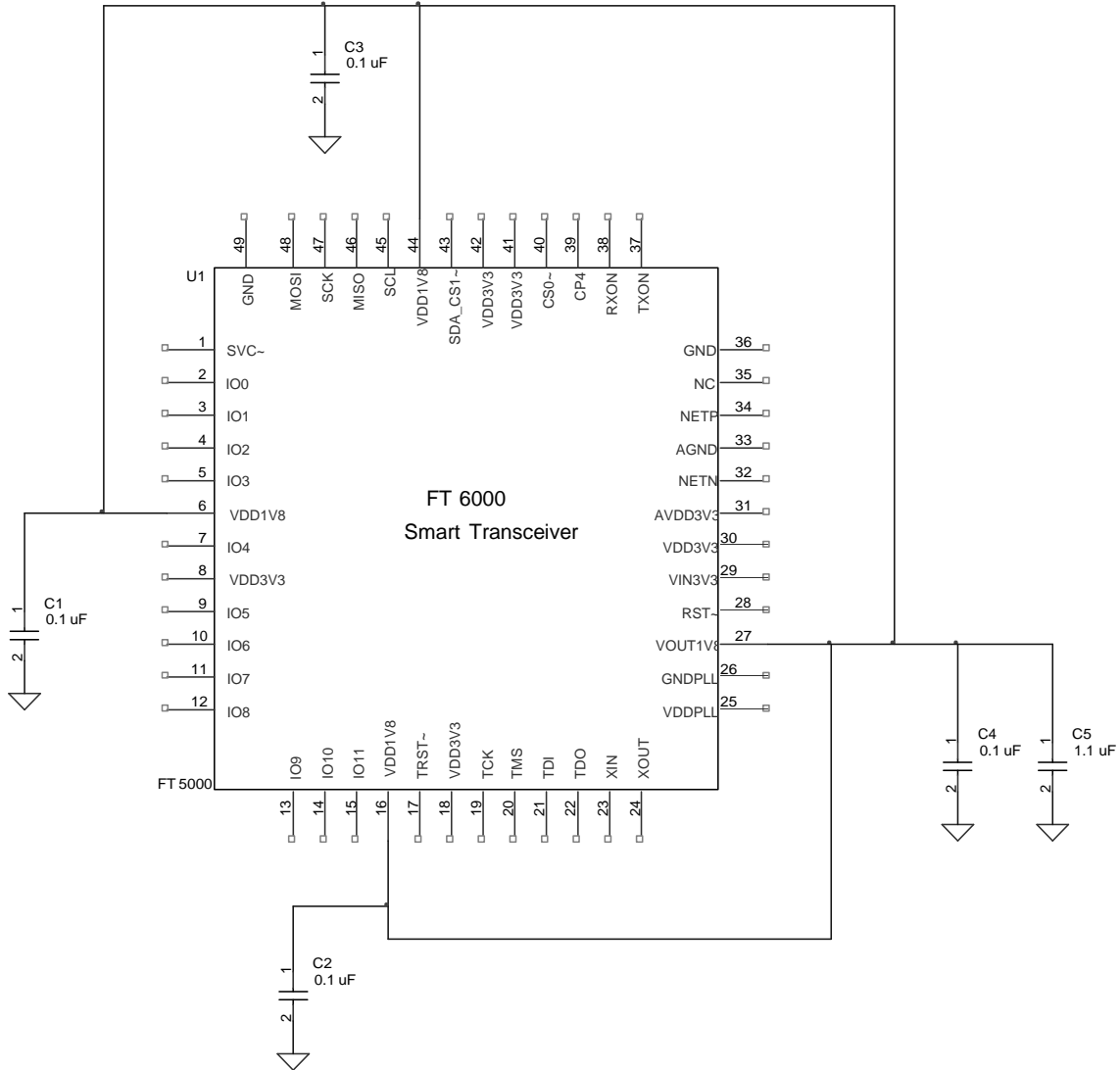
**Figure 10.** Connections for the VDD33 Pins

In the figure, the capacitors are:

- **C1-C4:** 0.1  $\mu$ F Ceramic

The **VOUT1V8** pin (27) is the output of the on-chip voltage regulator. Connect the **VDD1V8** pins (6, 16, and 44) to the **VOUT1V8** pin (27) to connect the 1.8 V input pins to the output of the internal voltage regulator, as shown in **Figure 11**. Connect a bulk decoupling capacitor (**C5** in **Figure 11**) near the **VOUT1V8** pin (27), in addition to the other decoupling capacitor.

**Important:** Do not connect an external 1.8 V source to any of the **VDD1V8** pins (6, 16, and 44). Connect these pins to the **VOUT1V8** pin (27) only. **Using an external 1.8 V source voids the warranty for the chip, and can cause unpredictable and possibly irreparable results.**

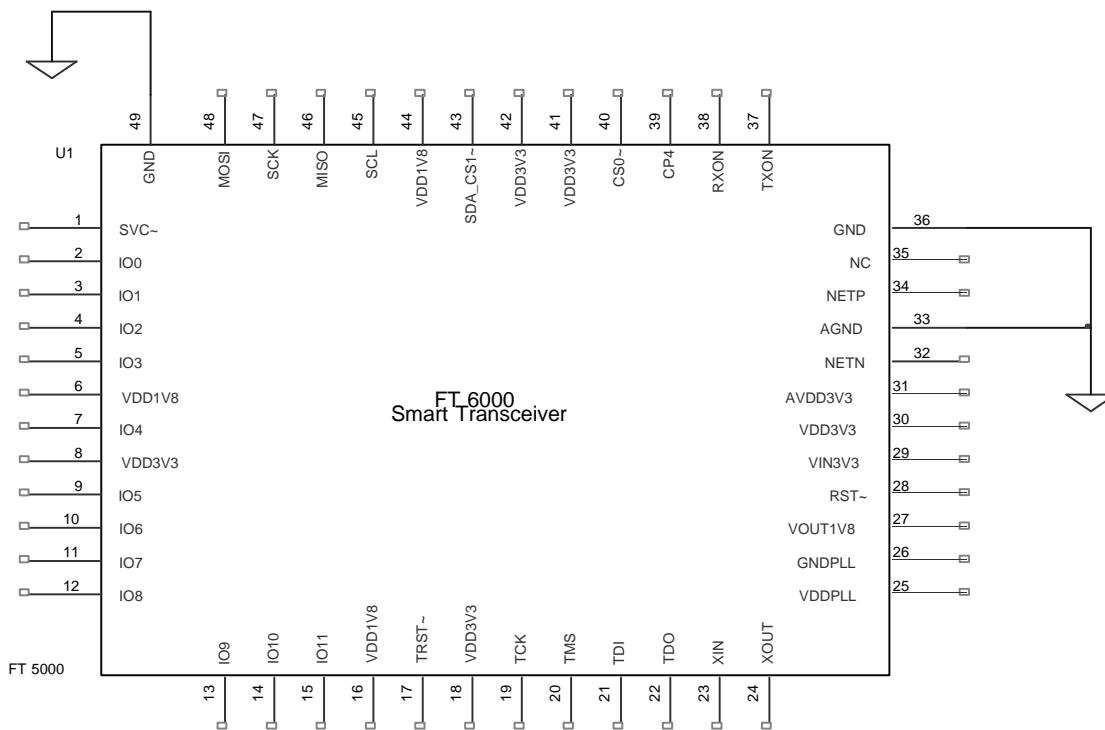


**Figure 11.** Connections for the VDD18 Pins

In the figure, the capacitors are:

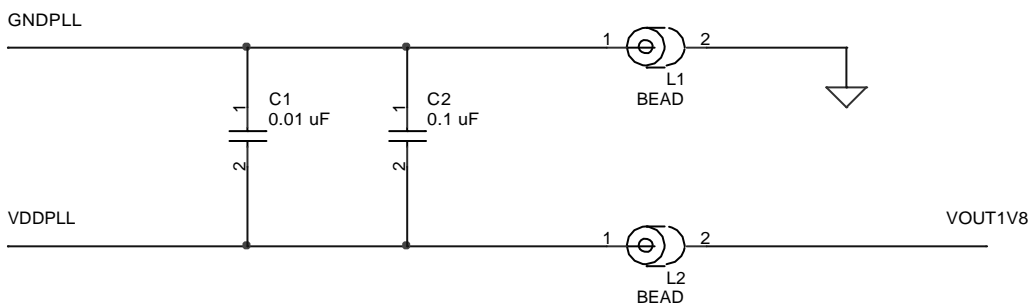
- **C1-C4:** 0.1  $\mu$ F Ceramic
- **C5:** 1.0  $\mu$ F Ceramic

Connect the chip's pad (pin 49) to logic ground. Also connect the **AGND** pin (33) to logic ground. **Figure 12** shows the connections for the ground pins.



**Figure 12.** Connections for the Ground Pins

Connect the **VDDPLL** pin (25) to the **VOUT1V8** pin (27), with an associated chip ferrite bead, as shown in **Figure 13**. Connect the **GNDPLL** pin (26) to GND, with an associated chip ferrite bead. In addition, add stabilizing capacitors across the VDDPLL and GNDPLL pins. Place each capacitor directly adjacent to the PLL pins, on the top layer of the PCB.



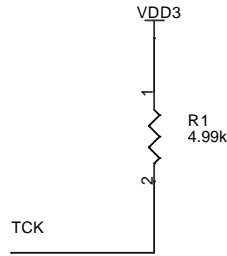
**Figure 13.** Connections for the PLL Pins

In the figure, the capacitors are:

- **C1:** 0.01  $\mu\text{F}$  Ceramic
- **C2:** 0.1  $\mu\text{F}$  Ceramic

The chip ferrite beads should be rated for  $\geq 50$  mA saturation current, provide  $\geq 120 \Omega$  impedance at 100 MHz per  $20^\circ\text{C}$ , and have a DC resistance  $\leq 1 \Omega$ . An example part is the Laird Technologies<sup>®</sup> LI0603E151R-10 part (formerly a Steward part).

Connect a 1 to 10 k $\Omega$  pull-up resistor to the JTAG **TCK** pin (19), as shown in **Figure 14**.



**Figure 14.** Connection for the JTAG TCK Pin

## Characteristics of the Digital Pins

Series 6000 chips provide 12 bidirectional I/O pins that are usable in several different configurations. These pins provide flexible interfacing to external hardware and access to the internal timer/counters. In addition to reading the input pins, the application processor can read the current logic level of the output pins.

The digital I/O pins (**IO0 – IO11**) have LVTTL-level inputs. Pins **IO0 – IO7** also have low-level-detect latches. The **RST~** and **SVC~** pins have internal pull-ups, and the **RST~** pin has hysteresis.

See the *I/O Model Reference for Smart Transceivers and Neuron Chips* for more information about how to use the digital I/O pins.

**Table 16** lists the characteristics of the digital I/O pins, which include the **IO0 – IO11** pins, the memory I/O pins, the Neuron 6000 **CP0 – CP4** pins, and the other digital pins listed in **Table 14** and **Table 15**.

**Table 16.** Series 6000 Chip Digital Pin Characteristics

Parameter <sup>[1]</sup>	Description	Minimum	Typical	Maximum
V <sub>OH</sub>	Output drive high at I <sub>OH</sub> = 8 mA	2.4 V	—	V <sub>DD3</sub>
V <sub>OL</sub>	Output drive low at I <sub>OL</sub> = 8 mA	GND	—	0.4 V
V <sub>IH</sub>	Input high level	2.0 V	—	5.5 V
V <sub>IL</sub>	Input low level	GND	—	0.8 V
V <sub>HYS</sub>	Input hysteresis for <b>RST~</b> pin and <b>TCK</b> pin	—	300 mV	—
I <sub>IN</sub>	Input leakage current	—	—	10 μA
R <sub>PU</sub>	Pullup resistance <sup>[2]</sup>	13 kΩ	—	23 kΩ
I <sub>PU</sub>	Pullup current when pin at 0 V <sup>[2]</sup>	130 μA	—	275 μA

**Notes:**

1. All parameters assume nominal supply voltage ( $V_{DD3} = 3.3\text{ V}$ ) and operating temperature ( $T_A$  between  $-40\text{ }^\circ\text{C}$  and  $+85\text{ }^\circ\text{C}$ ), unless otherwise noted.
2. Applies to **RST~** and **SVC~** pins only.

## Communications Port (CP) Pins for the Neuron 6000 Processor

The Neuron 6000 Processor has a very versatile communications port. It consists of five pins (named CP0 through CP4) that can be configured to interface to a wide variety of media interfaces (network transceivers) and operates over a wide range of data rates.

The communications port can be configured to operate in one of two modes: single-ended mode or special-purpose mode. **Table 17** lists the pin assignments for the communications port pins for each of the modes, and **Figure 15** shows a block diagram of the communications port.

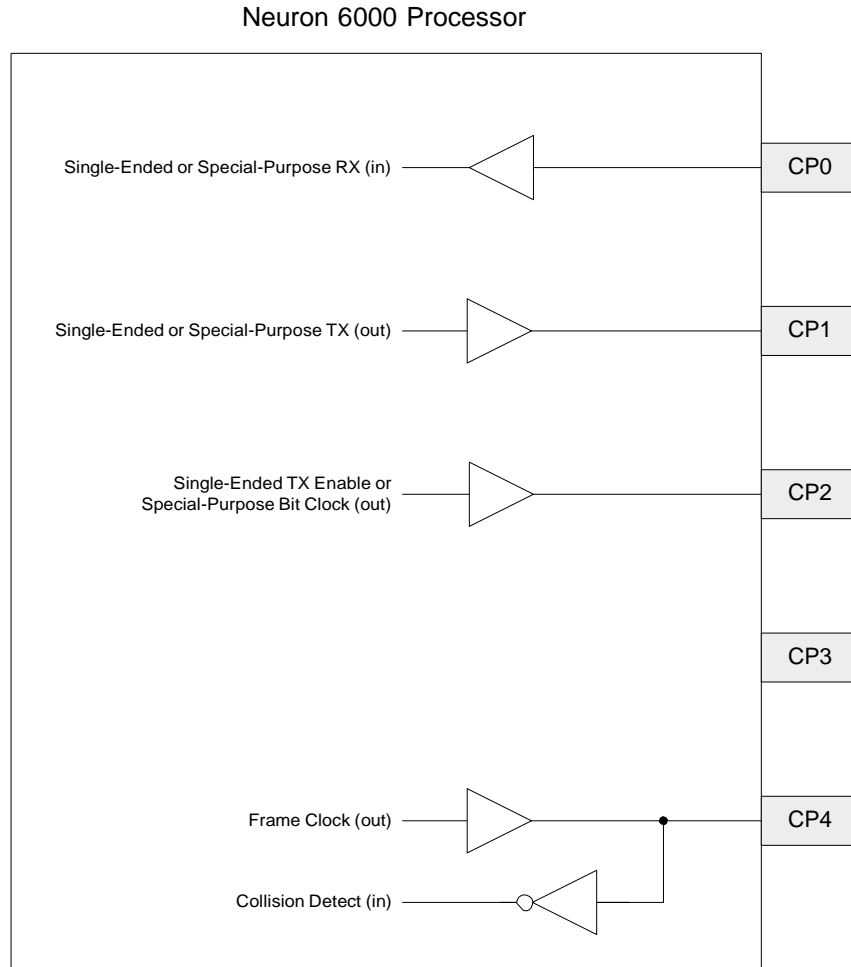
**Table 17.** Communications Port Pin Assignments

Pin	Drive Current	Single-Ended Mode (3.3 V)	Special-Purpose Mode (3.3 V)	Connect To
CP0	N/A	Data input	Rx input	Transceiver RXD
CP1	8 mA	Data output	Tx output	Transceiver TXD
CP2	8 mA	Transmit Enable output	Bit Clock output	Transmit Enable (single ended mode) Bit Clock (special-purpose mode)
CP3	N/A	Do Not Connect		
CP4	8 mA	Collision Detect input	Frame Clock output	Collision Detect (single ended mode) Frame Clock (special-purpose mode)

Before programming, a Neuron 6000 Processor uses its default communications parameters, which define a simplified single-ended mode 78 kbps channel. The default communications parameters allow you to load an application image over a 78 kbps network, for example during device manufacturing. Devices that use a 78 kbps transceiver (such as a 78 kbps EIA-485 transceiver or an LPT-11 Link Power Transceiver) can use the default communications parameters within development or manufacturing test networks. For production networks (networks with many devices), you should ensure that each device has communications parameters defined for the channel; use the IzoT NodeBuilder Development Tool to develop applications with the correct communications parameters. Note that devices defined for a TP/XF-1250 channel cannot use the default communications parameters; each



device's external serial non-volatile memory must be loaded with the correct communications parameters before connecting to the network.



**Figure 15.** Internal Transceiver Block Diagram

Single-ended mode uses Differential Manchester encoding (also known as bi-phase space encoding), which is a widely used and reliable format for transmitting data over various media. This encoding scheme provides a transition at the beginning of every bit period to synchronize the receiver clock (referred to as the *clock transition*). The data is indicated by the presence or absence of a second transition (the *data transition*) halfway between clock transitions. A mid-cell transition indicates a zero. Lack of a mid-cell transition indicates a one.

The transmitter transmits a *preamble* at the beginning of a packet to allow the other devices to synchronize their receiver clocks. The preamble consists of a bit-sync field and a byte-sync field. The bit-sync field is a series of Differential Manchester ones; its duration is user selectable, and is at least four bits long. The byte-sync field is a single bit Differential Manchester zero that marks the end of the preamble, and the beginning of the first data byte of the packet.

The Neuron Chip terminates the packet by forcing a Differential Manchester code violation, that is, the Neuron Chip holds the data output transitionless long enough for the receiver to recognize an invalid code that signals the end of transmission. The data output can be either high or low for the duration of the line-code violation, depending on the state of the data

output after transmitting the last bit. The line-code violation begins after the end of the last CRC bit, and lasts for at least 2.5 bit times. The last bit does not have a trailing clock edge. The Transmit Enable pin is held active until the end of the line-code violation, and is then released.

Differential Manchester coding is polarity-insensitive. Thus, reversal of polarity in the communication link does not affect data reception.

A Neuron Chip in single-ended mode supports any of the following network bit rates:

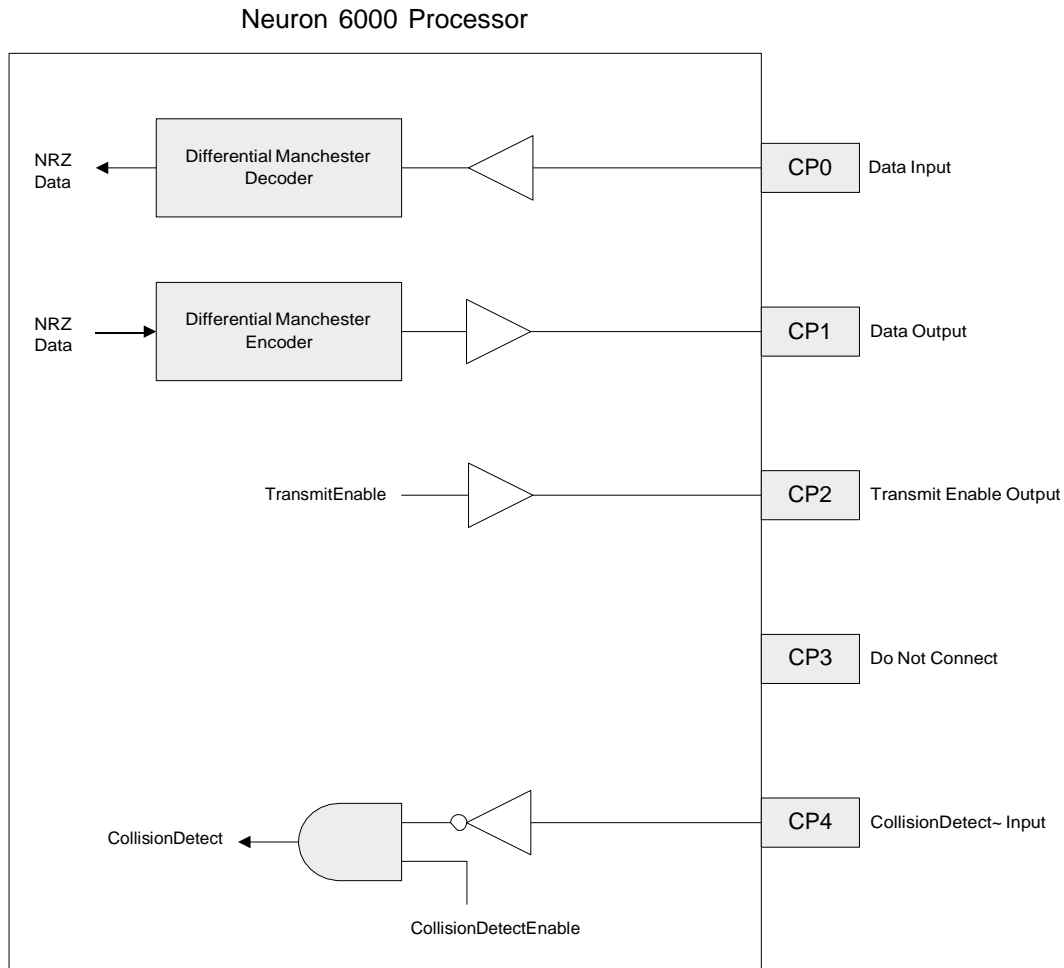
- 2.5 Mbps
- 1.25 Mbps
- 625 kbps
- 312.5 kbps
- 156 kbps
- 78 kbps
- 39 kbps
- 19.5 kbps
- 9.6 kbps
- 4.8 kbps

The 625 kbps and lower bit rates are available for any of the system-clock rates of the Neuron 6000 Processor. The 2.5 Mbps bit rate requires the Neuron 6000 Processor's system clock to be set at 40 MHz or higher, and the 1.25 Mbps bit rate requires the clock to be set to 20 MHz or higher.

---

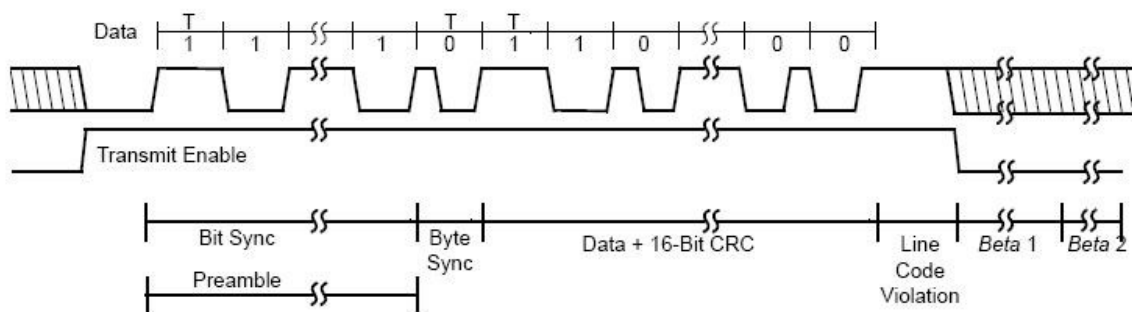
## *Single-Ended Mode*

Single-ended mode (3.3 V) is most commonly used with external active transceivers that interface to media such as RF, IR, fiber optics, twisted-pair cable, and coaxial cable. **Figure 16** shows the communications port configuration for single-ended mode operation. Data communication occurs through the single-ended (with respect to GND) input and output buffers on pins CP0 and CP1.



**Figure 16.** Single-Ended Mode Configuration

**Figure 17** shows a typical packet, where  $T$  is the bit period, equal to  $1/(\text{bit rate})$ . Clock transitions occur at the beginning of a bit period, and therefore, the last valid bit in the packet does not have a trailing clock edge.



**Figure 17.** Single-Ended Mode Data Format

Before beginning to transmit the packet, the Neuron Chip initializes the output data pin to start low. It then asserts the Transmit Enable pin (CP2) to ensure that the first transition in the packet is from low to high. This first transition occurs within 1 bit time of asserting Transmit Enable, and marks the beginning of the packet.

**Important:** Transmit Enable is actively driven at all times in single-ended mode. In single-ended mode, the 8 mA driver is connected to CP1 and it is not high impedance when receiving packets.

At the end of the packet after the Differential Manchester code violation, the Transmit Enable pin on CP2 is driven low to indicate the end of transmission.

## Collision Detection for Single-Ended Mode

As an option, the Neuron Chip accepts an active-low Collision Detect input from the transceiver. If collision detection is enabled, and CP4 goes low for at least one system clock period (12.5 ns with an 80 MHz system clock) during transmission, the Neuron Chip is signaled that a collision has occurred (or is occurring) and that the message must be sent again. The device then attempts to re-access the channel.

The collision detect flag is checked by firmware at the end of the preamble and end of packet. If the node does not use collision detection, the only way that it can determine that a message has not been received is to request an acknowledgment. When acknowledged service is used, the retry timer is set to allow sufficient time for a message to be sent and acknowledged (typically 48 ms to 96 ms at 1.25 Mbps when there are no routers in the transmission path). If the retry timer times out, the device attempts to re-access the channel. The benefit of using collision detection is that the device does not have to wait for the retry timer to time-out before attempting to resend the message, because the device detects the collision when it sends the packet.

## Beta 1 and Beta 2 Timeslots in Single-Ended Mode

**Important:** The information in this section applies only to development of new network types. If you use a standard LONMARK channel in a LONWORKS network, you do not need to work with the Beta 1 and Beta 2 timeslots.

The idle period between packets comprises the *Beta 1* and *Beta 2* timeslots. The *Beta 1* time is the fixed component in the idle period after a packet has been sent. This component is a function of the following:

- Oscillator frequencies and accuracies on the various network devices.
- Media indeterminate time — that time following packet transmission when the network can appear to be busy due to ringing on the line.
- Minimum interpacket gap — transceiver-dependent timing requirements.
- Receive-end delay — skew between the transmitter Neuron Chip's and the receiver Neuron Chip's view of the end of the packet. This skew can occur because of buffering in the transceivers, and is typically found in special-purpose mode transceivers.

The Media Access Control (MAC) Layer timings are a function of five parameters stored in the configuration data. These parameters determine the Preamble Length, the Packet Cycle, the Beta 2 Slot Width, the Transmit Interpacket Padding, and the Receive Interpacket Padding.

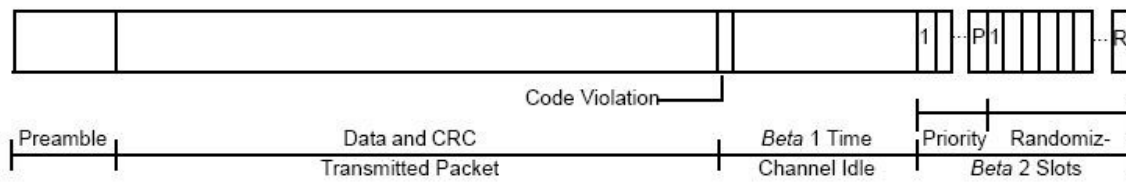
All timings are given in terms of the Neuron Chip processor cycles. One cycle is 37.5 ns at 80 MHz, 75 ns at 40 MHz, 150 ns at 20 MHz, 0.3  $\mu$ s at 10 MHz, and 0.6  $\mu$ s at 5 MHz:

- Beta 1 Time after Transmission = 583 cycles + Transmit Interpacket Padding + Beta 2 Slot Width
- Beta 1 Time after Reception = 565 cycles + Receive Interpacket Padding + Beta 2 Slot Width

An indeterminate time is defined during the Beta 1 period in which all transitions on the channel are ignored. This period starts following the end of any packet (transmitted or received). Its duration is defined as follows:

- Indeterminate Time after transmission = 313 cycles + Transmit Interpacket Padding
- Indeterminate Time after reception = 295 cycles + Receive Interpacket Padding

Both priority (P) and non-priority slots are defined by the *Beta 2* time. Devices listen to the network prior to transmitting a packet. This prevents devices from transmitting packets on top of each other except when the packets are initiated at nearly the same time. In addition, devices randomize the time before they start transmitting on the network. When the network is idle, all nodes randomize over 16 slots. As the estimated network load increases, devices start randomizing over more slots to lower the probability of a collision. The number of randomizing slots (R) varies from 16 up to 1008, based on “n,” the estimated channel backlog (the number of slots is  $n \cdot 16$  where “n” has a range of 1 to 63), as shown in **Figure 18**.



**Figure 18.** Packet Timing

Following a packet, and prior to randomizing, devices wait for a configurable number of priority slots to pass. Devices with priority packets and a configured priority slot transmit in a priority slot. Use of priority substantially reduces the probability of collision. The number of priority slots (P) is fixed for a given channel and can range from 0 to 127.

The Beta 2 time is defined by the following:

- Oscillator frequencies and accuracies on the various network devices.
- Number of priority slots on the channel.
- Receive start delay — the time from when a device starts transmitting to when the receiving device detect the start of transmission. This delay is a function of the receive-to-transmit turnaround time of the transceiver, the bit rate and length of the media, delay through the receiver, and initial preamble bits lost.
- For special-purpose mode transceivers, framing delays between the Neuron Chip and the transceiver.

For the receiver to detect the edge transitions, two windows are set up for each bit period, T. The first window is set at T/2 and determines if a zero is being received. The second window is at T and defines a one. This transition then sets up the next two windows (T/2 and T). If no transition occurs, a Differential Manchester code violation is detected and the packet is assumed to have ended.

**Table 18** shows the width of this window. If a transition falls outside of either window, it is not detected. Timing instability of the transitions, known as jitter, can be caused by changes

in the communications medium, or instability in the transmitting or receiving device's input clocks. The jitter tolerance windows are expressed as fractions of the bit period, T.

**Table 18.** Receiver Jitter Tolerance Windows

Next Data Edge (Nominal)	Next Clock Edge (Nominal)	Line Code Violation to Receive (Minimum)
0.500T	1.000T	1.46T

For the receiver to reliably terminate reception of a packet, the received line-code violation period must have no transitions until the Neuron Chip detects the end of the packet. The receiving Neuron Chip terminates a packet if no clock transitions are detected after the last bit. **Table 18** shows the minimum duration from the last clock edge to where the Neuron Chip is guaranteed to recognize the line-code violation. Data transitions are allowed in this period (and must fall within the data window).

For a Neuron Chip, the time from when an application software call is issued to send a 12-byte message to when the packet is sent is approximately 175  $\mu$ s for an 80 MHz system clock (the time varies inversely with the system clock rate).

---

## Special-Purpose Mode

In special situations, it is desirable for the Neuron Chip to provide the packet data in an unencoded format and without a preamble. In this case, an intelligent transmitter accepts the unencoded data and does its own formatting and preamble insertion. The intelligent receiver then detects and strips off the preamble and formatting, and returns the decoded data to the Neuron Chip.

### PATENT NOTICE

The Special-Purpose Mode is protected by U.S. Patent No. 5,182,746 and foreign patents based on this patent. No express or implied license is granted herein with respect to such patents. If you are interested in obtaining a non-exclusive, royalty free license to these patents, please call Echelon at +1 (408) 938 5200 and ask for Contracts Management.

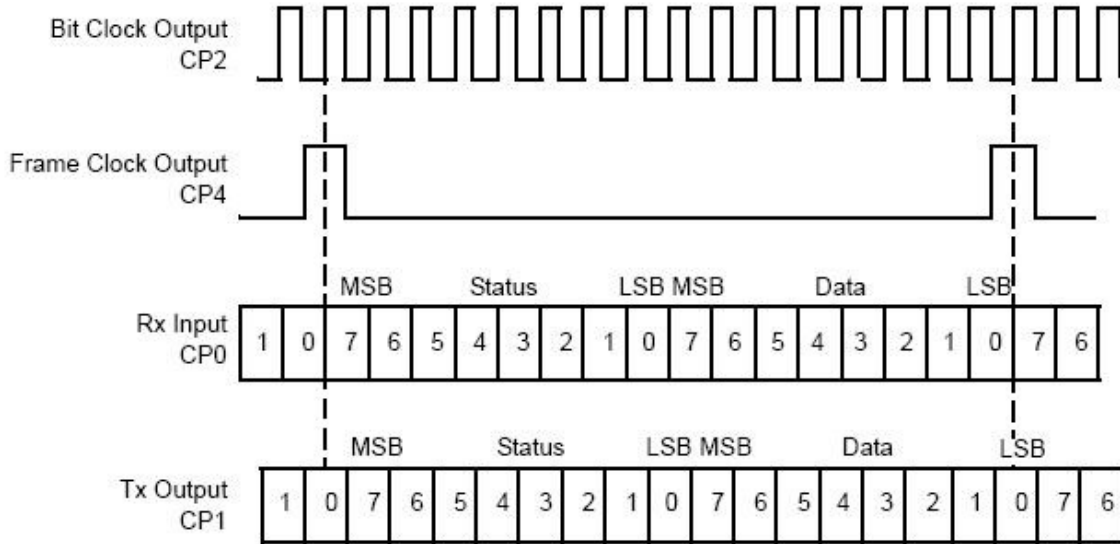
Such an intelligent transceiver contains its own input and output data buffers and intelligent control functions, and provides handshaking signals to properly pass the data back and forth between the Neuron Chip and the transceiver. In addition, there are many features that can be defined by and incorporated into a special-purpose transceiver:

- Ability to configure various parameters of the transceiver from the Neuron Chip
- Ability to report on various parameters of the transceiver to the Neuron Chip
- Multiple channel operation
- Multiple bit rate operation
- Use of forward error correction
- Media-specific modulation techniques requiring special message headers and framing
- Collision detection

While the special-purpose mode offers custom features, it is expected that most transceivers will use the single-ended mode for most types of media. This is because single-ended mode offers Differential Manchester encoding, which takes care of clock recovery, whereas special-purpose mode does not have this feature. In addition, the special-purpose mode is a

restricted protocol that Echelon licenses for use only when the Neuron Chip and transceiver are sold as one unit. For more details, contact Echelon Support.

When the special-purpose mode (3.3 V) is used, the Neuron 6000 Processor and the transceiver use a protocol that consists of the Neuron 6000 Processor and the transceiver each exchanging 16 bits (8 bits of status and 8 bits of data; see **Figure 19**) simultaneously and continuously at rates up to 20.0 Mbps (when the Neuron Chip's system clock is 80 MHz). The 20.0-Mbps bit rate allows time-critical flags, such as a Carrier Detect, to be exchanged across the interface with network bit rates up to 625 kbps. The maximum bit rate is 625 kbps because of the overhead associated with the handshaking.



**Figure 19.** Special-Purpose Mode Data Format

The Neuron Chip communicates with the transceiver through its CP[4:0] pins. CP4 and CP2 are synchronizing clocks generated by the Neuron Chip: CP4 is a frame clock, and CP2 is a bit clock. CP0 and CP1 contain the exchanged data: CP0 transfers data from the transceiver to the Neuron Chip, and CP1 transfers data from the Neuron Chip to the transceiver.

The Neuron Chip and transceiver continuously exchange data through its CP0 and CP1 pins. The bit clock defines transitions between bits in the data stream. The Neuron Chip uses the falling edge of the bit clock to both sample CP0 and change CP1 to the next bit. The transceiver should use the rising edge of bit clock to sample CP1 and update CP0.

The serial data streams on CP0 and CP1 are divided into 16-bit frames. The frame clock (CP4) is used to define the boundaries of the frames. The frame clock is active (high) while the Neuron Chip is outputting the least-significant bit (LSB) of the frame on CP1. On the falling edge of the frame clock, the Neuron Chip is sampling the most-significant bit (MSB) of the next frame on CP0.

The first eight bits of each frame are interpreted as the status field and the last eight bits as the data field. The status field controls transceiver operation and controls passing data between the Neuron Chip and the transceiver. The interpretation of each status bit is shown in **Table 19** and **Table 20**.

**Table 19.** Special-Purpose Mode Transmit Status Bits

Bit	Flag	Description
7	TX_FLAG	Neuron Chip in the process of transmitting packet
6	TX_REQ_FLAG	Neuron Chip requests to transmit on the network
5	TX_DATA_VALID	Neuron Chip is passing network data to the transceiver in this frame
4	Don't Care	Unused
3	TX_ADDR_R/W	If negated, Neuron Chip is writing internal transceiver register
2	TX_ADDR_2	Address bit 2 of internal transceiver register [1..7]
1	TX_ADDR_1	Address bit 1 of internal transceiver register [1..7]
0	TX_ADDR_0	Address bit 0 of internal transceiver register [1..7]
<p><b>Note:</b> For bits [2..0] the internal transceiver register 0 is not valid. Registers [1..7] are defined by the transceiver implementation.</p>		

**Table 20.** Special-Purpose Mode Receive Status Bits

Bit	Flag	Description
7	SET_TX_FLAG	Transceiver accepts request to transmit packet
6	CLR_TX_REQ_FLAG	Transceiver acknowledges request to transmit packet
5	RX_DATA_VALID	Transceiver is passing network data to the Neuron Chip in this frame
4	TX_DATA_CTS	Transceiver indicates that Neuron Chip is clear to send byte of network data
3	SET_COLL_DET	Transceiver has detected a collision while transmitting the preamble
2	RX_FLAG	Transceiver has detected a packet on the network
1	RD/WR_ACK	Transceiver acknowledges read/write to internal register
0	TX_ON	Transceiver is transmitting on the network

There are three types of data that can be sent and received during each frame:

1. Network packet data — Actual data (8 bits at a time) that is to be transmitted or has been received.



2. Configuration data — Information from the Neuron Chip that tells the transceiver how it is to be set up or configured.
3. Status data — Informational parameters reported from the transceiver to the Neuron Chip (when requested by the Neuron Chip).

The contents of the configuration data and status data are defined by the transceiver.

The Neuron Chip controls the communication with the transceiver by asserting and examining status bits. There are four basic operations that the Neuron Chip performs with the transceiver: transmit packet, receive packet, write configuration, and read status.

When the Neuron Chip wants to transmit a packet, it sets the TX REQ FLAG bit of its output status field. The transceiver can then accept or reject the request. To reject the request, the transceiver sets the CLR TX REQ FLAG bit and clears the SET TX FLAG bit. The transceiver indicates that it is ready to transmit by setting the CLR TX REQ FLAG and SET TX FLAG bits for one frame. In that same frame, the transceiver must also set the TX DATA CTS bit to indicate that the Neuron Chip can send the first byte of data.

The Neuron Chip sends a packet of data only if the transceiver accepts the transmit request. The Neuron Chip then sets the TX FLAG bit for the entire duration of the packet. The transceiver must set the TX ON bit while it is transmitting a packet.

Each byte is transferred from the Neuron Chip to the transceiver with a handshake protocol. The transceiver indicates that it is ready to accept a byte by setting the TX DATA CTS bit for a single frame. The Neuron Chip uses this flag to cause it to send out another byte in a subsequent frame; the Neuron Chip also sets the TX DATA VALID bit during the frame that contains the data byte.

After the Neuron Chip sends the last byte in the packet, it clears the TX FLAG bit to indicate the end of transmission. When the transceiver finishes transmitting the packet, including any error codes, it must clear the TX ON bit to indicate that it has released the network.

The transceiver can abort transmission if it detects a collision by setting the SET COLL DET bit for one frame. The Neuron Chip then clears the TX FLAG bit and prepares to resend the packet.

The transceiver initiates packet reception by setting the RX FLAG bit. The transceiver can begin sending data to the Neuron Chip in the frame after setting the RX FLAG bit. Each frame that contains valid data must be marked with the RX DATA VALID bit set. When the transceiver finishes receiving a packet, it clears the RX FLAG bit and the Neuron Chip terminates reception of the packet.

The Neuron Chip performs a configuration write or status read by using the TX ADDR R/W and TX ADDR [2:0] bits. The TX ADDR [2:0] bits indicate which of seven transceiver registers is being accessed, and the TX ADDR R/W bit indicates whether the operation is a configuration register write (0) or status register read (1). Register 0 (TX ADDR [2:0] = 000) is unused, so that TX ADDR R/W = 0 and TX ADDR [2:0] = 000 indicates no read or write operation is to be performed.

To write to a configuration register, the Neuron Chip clears the TX ADDR R/W bit and indicates the selected register with the TX ADDR [2:0] bits. The transceiver must acknowledge that the operation is complete by setting the RD/WR ACK bit. The Neuron Chip continues to send the configuration write command until it receives a frame with the RD/WR ACK bit set.

To read a status register, the Neuron Chip sets the TX ADDR R/W bit and indicates the selected register with the TX ADDR [2:0] bits. The transceiver must acknowledge that the operation is complete by setting the RD/WR ACK bit and by placing the requested

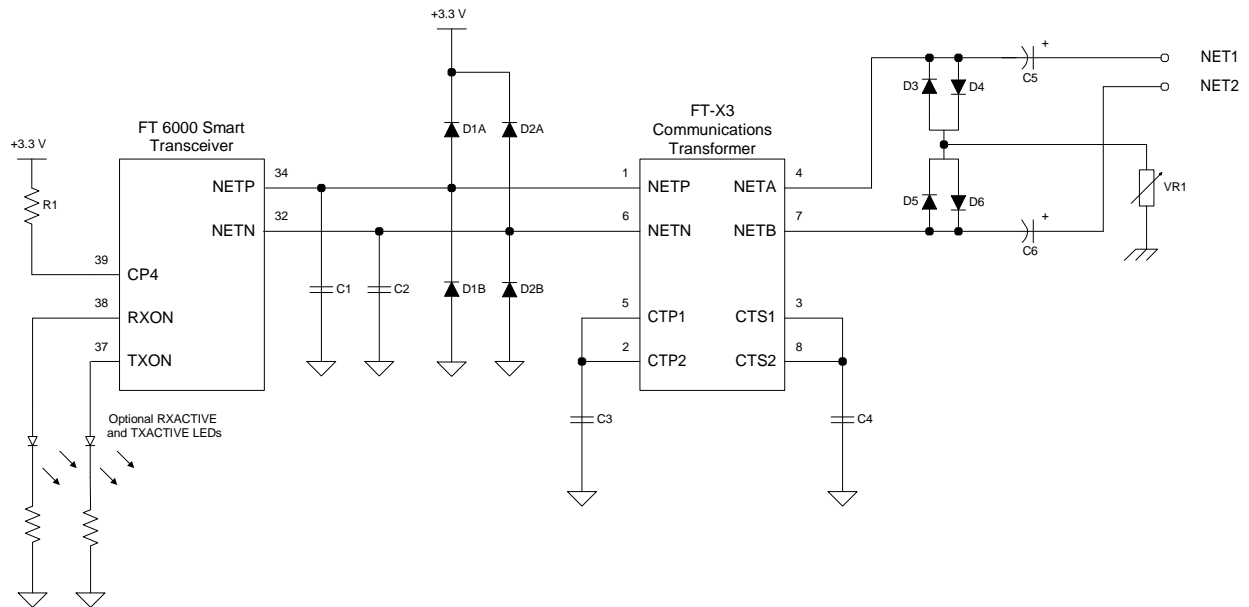
information in the data field. The Neuron Chip continues to send the status request command until it receives a frame with the RD/WR ACK bit set.

## Network Connection

How you connect a Series 6000 device to a network depends primarily on whether the Series 6000 device contains an FT 6000 Smart Transceiver or a Neuron 6000 Processor. For FT 6000 Smart Transceivers, you use the FT-X3 transformer; for Neuron 6000 Processors, you use an external transceiver and associated interconnect circuitry.

### Connection for an FT 6000 Smart Transceiver

**Figure 20** shows the preferred interconnection between the FT 6000 Smart Transceiver and the FT-X3 Communications Transformer; the figure also shows the associated transient protection circuitry. Connect pins 1 and 6 of the FT-X3 transformer to the FT 6000 Smart Transceiver, as shown in the figure. The figure is not a complete schematic, because it does not include the clock, reset, and power supply bypass circuits for the FT 6000 Smart Transceiver. See Appendix C, *FT-X3 Communications Transformer*, for a schematic view of the FT-X3 Communications Transformer.



**Figure 20.** FT 6000 Smart Transceiver and FT-X3 Interconnections

**Table 21.** External Components for FT 6000 Smart Transceiver

Name	Value	Description
R1	4.99 k $\Omega$	Pullup resistor
VR1	470 V MOV, 5 mm, 40 pF (typical)	Panasonic ERZV05D471, Digi-Key P7186-ND or equivalent

Name	Value	Description
C1, C2	56 pF, 50 V	Common-mode noise immunity capacitors (for EN61000-4-6 Level 3)
C3, C4	100 pF, 5%	Optional center-tap capacitors
C5, C6	22 $\mu$ F, $\geq$ 50 V, polar	DC blocking capacitors
D1, D2	BAV99	ESD transient clamping diodes
D3, D4, D5, D6	BAV99, 1N4148-equivalent 1N4934, 1N4935, FR1D, RS1D, RS1DB	Differential network clamping diodes: For up to 2 kV Surge Protection For up to 6 kV Surge Protection

In **Figure 20**, diodes D1 and D2 are ESD transient clamping diodes. Capacitors C1 and C2 provide common-mode noise immunity for compliance with EN61000-4-6 Level 3. Capacitors C5 and C6 are used to provide DC voltage isolation for the FT 6000 Smart Transceiver when it is used on a link power network and to protect it in the event of a DC power fault on the network wires. The capacitors are required to meet LONMARK interoperability guidelines for the TP/FT-10 channel. These capacitors are not needed for devices that will be connected exclusively to non-link power networks and do not require protection against DC faults. Two polar capacitors are used to protect against the application of a DC voltage of either polarity, while providing a total capacitance of 11  $\mu$ F. Alternatively, a single non-polar capacitor of 10  $\mu$ F can be used in either of the two legs that connect to the network. The initial tolerance of the capacitor should be  $\pm$ 20% or less, and degradation due to aging and temperature effects should not exceed 20% of the initial minimum value.

In some cases, adding capacitors (C3 and C4) between the center tap pins and earth ground can reduce EMI emissions.

Note that Series 3100 FT Smart Transceivers had a single **COMM\_ACTIVE** pin (equivalent to the CP2 pin for a Series 3100 Neuron Chip) that you could connect to a special **COMM\_ACTIVE** LED circuit to drive a pair of LEDs to display network activity. FT 6000 Smart Transceivers have two communications pins, **TXON** and **RXON**, that you can connect to network activity LEDs (**RXACTIVE** and **TXACTIVE**) without any special circuitry requirements. However, you might want to add pulse-stretching circuitry for these packet-activity signals for increased visibility. If your device does not require network activity LEDs, pins 37 and 38 should be treated as No Connect.

## Comparison with FT 3120 or FT 3150 Devices

The interconnection with the network transformer for an FT 3120 Smart Transceiver or an FT 3150 Smart Transceiver is similar to the interconnection for an FT 6000 Smart Transceiver (as described in *Connection for an FT 6000 Smart Transceiver*). However, FT 3120 and FT 3150 Smart Transceivers can use one of three transformers: the FT-X1 (a through-hole part), the FT-X2 (a surface-mount part), or the FT-X3 (a surface-mount part).

Although you can use an FT-X1 or FT-X2 transformer with an FT 6000 Smart Transceiver, you cannot simply replace an existing FT 3120 or FT 3150 Smart Transceiver with an FT 6000 Smart Transceiver. The voltage requirement is different (the FT 6000 Smart

Transceiver is a 3.3 V part and the FT 3120 or FT 3150 Smart Transceiver is a 5 V part); the packages are different; and the pinouts are different. In addition, if your Series 3100 device uses a COMM\_ACTIVE circuit to drive network-activity LEDs, the requirements for that circuit are very specific for FT 3120 or FT 3150 Smart Transceivers, whereas for FT 6000 Smart Transceivers, you can use a simple LED driver circuit for the two network activity LEDs.

See the *FT 3120 / FT 3150 Smart Transceiver Data Book* for more information about the interface for FT 3120 or FT 3150 Smart Transceivers.

## Comparison with Series 5000 Devices

For details of new features of the Series 6000 parts, please see *What's New for Echelon's Smart Transceivers and Neuron Chips*

The pinout and packaging of both Series 5000 and Series 6000 parts are identical, thus enabling a simple transition.

## Comparison with the FTT-10A Transceiver

The FTT-10A transceiver is designed to be used with Neuron Chips (Series 3100, Series 5000, and Series 6000). The migration path from a Series 3100 Neuron Chip to a Series 3100 Smart Transceiver is fairly straightforward:

- The Series 3100 Smart Transceiver has the same footprint as the corresponding Series 3100 Neuron Chip
- The FT-X1 transformer has the same footprint as the FTT-10A transceiver
- The pinout of the FT-X1 transformer is compatible with the connections between the Series 3100 Neuron Chip and the FTT-10A transformer

See the *FT 3120 and FT 3150 Smart Transceiver* datasheet for more detailed information on these pinouts and footprints.

A device based on a Series 3100 Smart Transceiver with the FT-X1 or FT-X2 transformer can run the same applications with the same functionality as a 3100 Neuron Chip with an FTT-10A transceiver. In addition, Series 3100 Smart Transceiver with the FT-X1, FT-X2, or FT-X3 transformer has the same levels of transient immunity, but has improved magnetic field noise immunity, and improved common-mode network noise immunity (as tested per EN 61000-4-6). See the *FT 3120 / FT 3150 Smart Transceiver Data Book* for more information migrating from a 3100 Neuron Chip with an FTT-10A transceiver to a Series 3100 Smart Transceiver with the FT-X1 or FT-X2 transformer.

The migration path from a Series 3100 Neuron Chip to a Series 6000 Smart Transceiver requires additional design work:

- The Series 6000 Smart Transceiver is a 3.3 V part and the Series 3100 Neuron Chip is a 5 V part
- The Series 6000 Smart Transceiver has a different footprint compared to the corresponding Series 3100 Neuron Chip
- The FT-X3 transformer has a different footprint compared to the FTT-10A transceiver
- The pinout of the FT-X3 transformer is not entirely compatible with the connections between the Series 3100 Neuron Chip and the FTT-10A transformer

A device based on a Series 6000 Smart Transceiver with the FT-X3 transformer can run the same applications (after they are recompiled for the FT 6000 Smart Transceiver) with the same functionality as a 3100 Neuron Chip with an FTT-10A transceiver or a Series 3100 Smart Transceiver with a FT-X1 or FT-X2 transformer. In addition, a Series 6000 Smart Transceiver with the FT-X3 transformer has the same levels of transient immunity, magnetic field noise immunity, and common-mode network noise immunity (as tested per EN 61000-4-6) as a Series 3100 device.

---

## Connection for a Neuron 6000 Processor

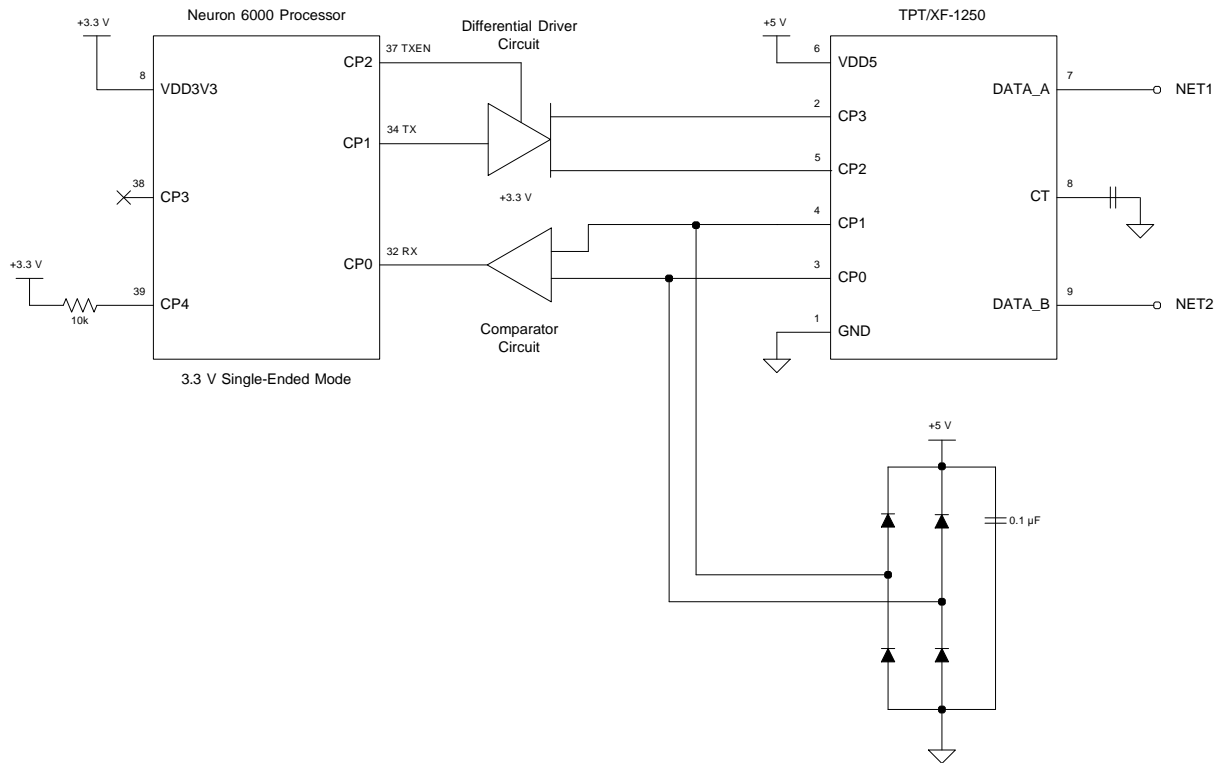
You can connect a Neuron 6000 Processor to an external transceiver to communicate with a TP/XF-1250 channel, an EIA-485 network, a link-power TP/FT-10 channel, or other transceivers. Use an FT 6000 Smart Transceiver for a standard (non-link-powered) TP/FT-10 channel or for a locally powered device on a link-power TP/FT-10 channel.

### TPT/XF-1250 Transceivers

You can use the Neuron 6000 Processor with an Echelon TPT Twisted Pair Transceiver Module for a TP/XF-1250 channel type. However, because the Neuron 6000 Processor does not include an on-chip differential transceiver (that is, the Neuron 6000 Processor does not support the differential mode of operation that Neuron 3120 Chips and Neuron 3150 Chips supported), you must:

- Select “TP/XF-1250” as the transceiver type within the Hardware Template Editor of the IzoT NodeBuilder Development Tool. This selection causes the Neuron firmware to configure the Neuron 6000 Processor’s communications port to operate in 3.3 V single-ended mode.
- Add a single-ended mode to differential mode converter circuit, as described in the *Connecting a Neuron 5000 Processor to an External Transceiver* Engineering Bulletin (005-0202-01B). This circuit converts the Neuron 5000 or Neuron 6000 Processor’s 3.3 V single-ended mode signals to the 5 V differential mode signals required for the TPT/XF-1250 transceiver.

**Figure 21** shows the basic configuration for connecting a Neuron 6000 Processor to a TPT/XF-1250 transceiver.



**Figure 21.** Connecting a Neuron 6000 Processor to a TP/XF-1250 Transceiver

In the figure, the pullup resistor for the Neuron Chip's CP4 pin is optional, but helps prevent contention on the CP4 pin if the Neuron Processor is incorrectly configured to operate in special-purpose mode (for which the CP4 pin is an output). The diode clamps for the TPT/XF-1250 transceiver's CP0 and CP1 signals are high-speed switching diodes, such as Fairchild Semiconductor® 1N4148 small-signal diodes. The value of the capacitor on the TPT/XF-1250 transceiver's transformer center tap (CT) pin depends on the device's PCB layout and EMI characteristics. A typical value is 100 pF rated for 1000 V. For more information about the TPT/XF-1250 transceiver, see the *LONWORKS TPT Twisted Pair Transceiver Module User's Guide* (078-0025-01C).

The details of the required differential driver circuit and the comparator circuit for the Neuron 5000 or Neuron 6000 are described in the *Connecting a Neuron 5000 Processor to an External Transceiver* Engineering Bulletin (005-0202-01B).

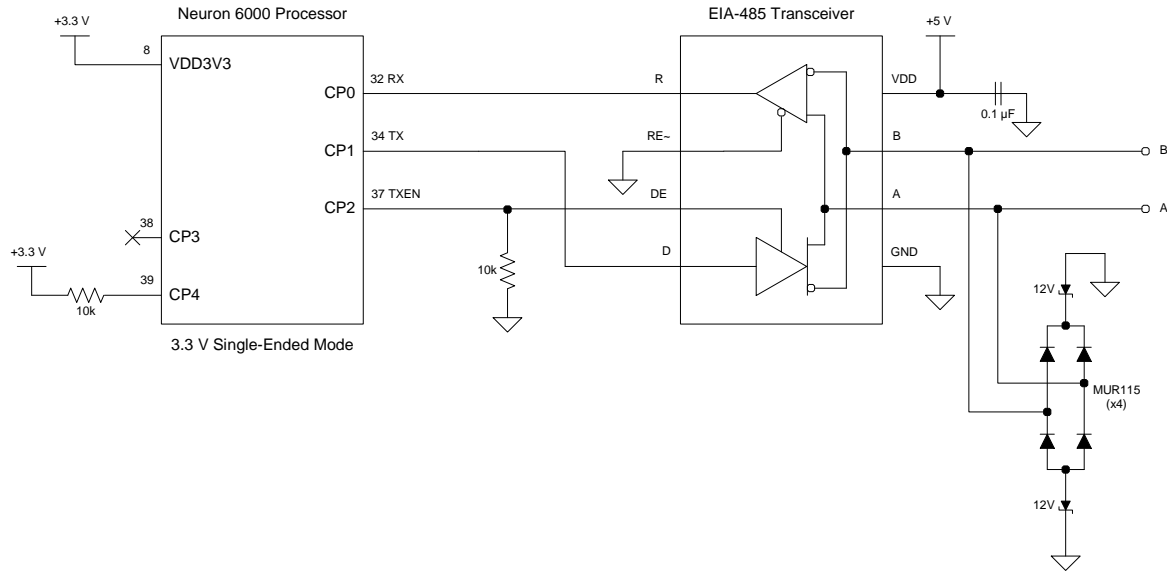
## EIA-485 Transceivers

You can use the Neuron 6000 Processor with commercially available EIA-485 transceivers. Multiple data rates (up to 1.25 Mbps), and a number of wire types can be supported. With an EIA-485 transceiver, common-mode voltage ranges between  $-7$  V to  $+12$  V. To implement an EIA-485 device, the Neuron 6000 Processor's communications port runs in single-ended mode.

Available industry standards that describe EIA-485 specifications provide details on unit loads, data rate, wire size, and wire distances. To ensure interoperability between devices, the LONMARK interoperability guidelines require a data rate of 39 kbps for devices that use EIA-485 transceivers. In addition, the EIA-485 transceiver must have TTL-compatible

inputs for the connection to the Neuron 6000 Processor. A typical circuit configuration, shown in **Figure 22**, can support up to 32 loads.

Individual device power sources can create problems when the common voltage exceeds  $-7\text{ V}$ ,  $+12\text{ V}$ , or with ground faults.



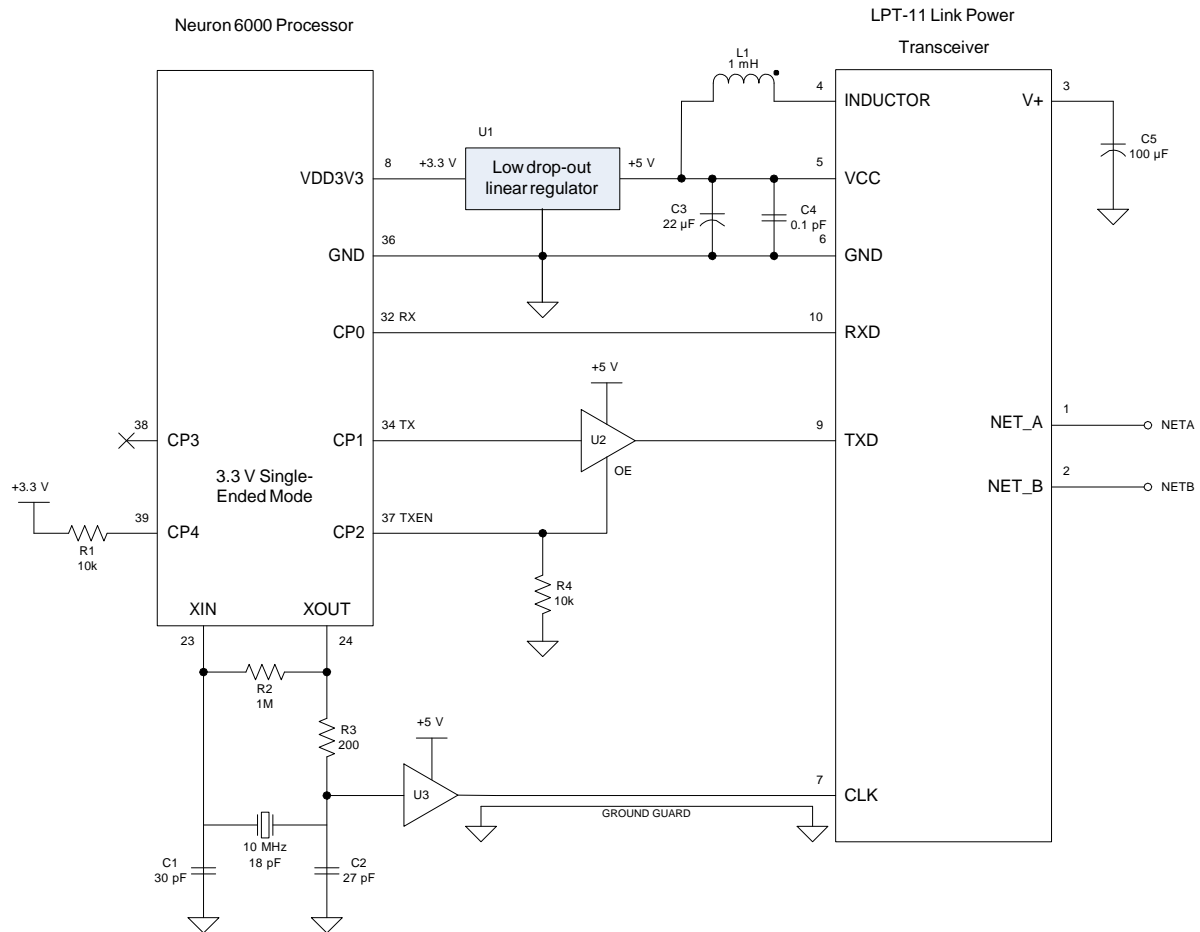
**Figure 22.** EIA-485 Twisted-Pair Interface (Uses Single-Ended Mode)

The EIA-485 specification requires a common ground reference for all transceivers. This common ground reference can be provided by adding a third conductor in the network cable or a separate connection to common ground at each device.

## LPT-11 Link Power Transceivers

The Echelon LONWORKS LPT-11 Link Power Twisted Pair Transceiver provides a simple, cost effective method for adding a network-powered LONWORKS transceiver to any Neuron Chip-based sensor, activator, display, lighting device, or general purpose I/O controller. The LPT-11 transceiver eliminates the need to use a local power supply for each device, because device power is supplied by a central power supply over the same twisted wire pair that handles network communications.

**Figure 23** shows the basic configuration for connecting a Neuron 6000 Processor to an LPT-11 Twisted-Pair Link Power Transceiver.



**Figure 23.** Connecting a Neuron 6000 Processor to an LPT-11 Link Power Transceiver

The major differences between connecting a Series 3100 Neuron Chip to an LPT-11 transceiver (see the *LONWORKS LPT-11 Link Power Transceiver User's Guide*, 078-0198-01A) and connecting a Neuron 6000 Processor to an LPT-11 transceiver are:

- The connection between the LPT-11 VCC pin and the Neuron 6000 VDD3V3 pin requires the addition of a low drop-out linear regulator to convert the +5 V output from the LPT-11 transceiver to the +3.3 V input for the Neuron 6000 Processor.
- The connection between the LPT-11 TXD pin and the Neuron 6000 CP1 pin requires the addition of a non-inverting bus buffer/line driver that supports TTL-compatible input and 5V CMOS output. The output of the Neuron CP2 pin is also connected to the buffer/line driver to allow the Neuron 6000 Processor to propagate a device reset to the LPT-11 transceiver by setting the buffer/line driver to a tri-state impedance state. An example part for the buffer/line driver is an NXP® 74AHCT1G126 bus buffer/line driver.
- The connection between the LPT-11 CLK pin and the Neuron 6000 XOUT pin requires the addition of a standard (inverting or non-inverting) bus buffer/line driver that supports TTL-compatible input and 5V CMOS output.

See the *Connecting a Neuron 5000 Processor to an External Transceiver Engineering Bulletin* (005-0202-01B) for additional information.



---

## Clock Requirements

A Series 6000 chip requires a 10 MHz external crystal or oscillator to provide its input clock signal. The chip then multiplies the input frequency by an amount specified in the device's hardware template (specified during device development using the IzoT NodeBuilder Development Tool) to derive its internal system clock frequency. For multipliers greater than one, the chip uses a phase-locked loop (PLL) to drive and manage the internal on-chip system clock frequency.

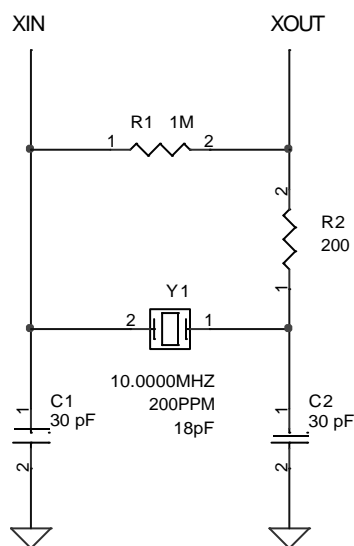
This section describes the requirements for the external crystal and compares terminology for Series 6000 chip clock frequencies with Series 3100 chip clock frequencies.

---

### External Crystal

A Series 6000 chip requires a 10.0 MHz external clock signal for operation. An example part that meets the requirements for a Series 6000 chip is the Abracon Corporation ABMM2100000MHZD1 Ceramic Surface Mount Low Profile Quartz Crystal.

The crystal must have a load capacitance rating of 18 pF. Because a Series 6000 chip does not have internal load capacitance on-chip, you must add 30 pF combined external series capacitance, as shown in **Figure 24**.

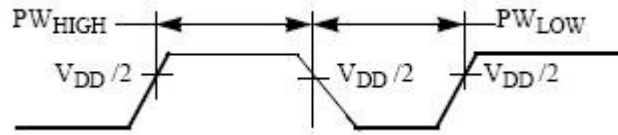


**Figure 24.** Series 6000 Chip Clock Generator Circuit

Unlike the Series 3100 chip, the Series 6000 chip's **XOUT** pin cannot be used to drive an external CMOS load. However, if you maintain the required capacitance for the **XOUT** pin, you can drive an external clock, for example, as shown for the LPT-11 Link-Power Transceiver in **Figure 23**.

If your device requires a common clock signal, you can use an external 3.3 V oscillator module (such as a Vishay® Intertechnology XOSM-533 Surface Mount Oscillator), and leave **XOUT** unconnected. You could also define an output frequency I/O model for one of the Series 6000 chip's I/O pins (IO0..IO11) and connect the load's clock signal to the Series 6000 chip's I/O pin.

A 60/40 duty cycle or better is required for the external oscillator, as shown in **Figure 25**. An external oscillator must provide low-voltage transistor-transistor logic (LVTTL) voltage levels (0 to 3.3 V) to the **XIN** pin.



**Figure 25.** Test Point Levels for XIN Duty-Cycle Measurements

To ensure proper oscillator startup, the equivalent series resistance specification for the crystal should be  $\leq 50 \Omega$ , and the crystal shunt capacitance should be no greater than 7 pF.

A Series 6000 chip requires a clock frequency with a total accuracy of  $\pm 200$  ppm over the full range of component tolerances and operating conditions, including oscillator tolerance, crystal tolerance, PCB and capacitor variation, and aging. Variation within the Series 6000 chip uses a portion of the overall  $\pm 200$  ppm budget. Its duty cycle symmetry must be no worse than 60/40%. In addition, the voltage swing of the clock signal must be within the GND and  $V_{DD33}$  supply rails of the Series 6000 chip. This clock can be provided by connecting an appropriate parallel resonant crystal to the **XIN** and **XOUT** pins of the Series 6000 chip, as shown in **Figure 24**.

The remaining portion of the error budget allocated for *total crystal uncertainty* is  $\pm 85$  ppm (assuming that the selected crystal has a load capacitance specification that matches the circuit loading). *Total crystal uncertainty* is the combination of the crystal's initial frequency tolerance plus its temperature and aging tolerances. Note that a typical crystal aging specification is 5 ppm/yr but, because the aging effect tends to follow a logarithmic curve, aging over a 10 year span is commonly in the range of 10 to 15 ppm (contact individual crystal vendors for detailed specifications).

---

## Comparison with Series 3100 Clocks

For Series 3100 chips, you specified the value of the system clock through the use of a specific external crystal or oscillator (for example, a 10 MHz crystal). For Series 6000 devices, you specify the system clock rate through software tools (the IzoT NodeBuilder Development Tool). For a Series 6000 device, the external clock is *always* a 10 MHz crystal, but the internal system clock rate can vary from 5 MHz to 80 MHz.

Internally, a Series 3100 chip divided the external crystal's frequency by 2 to obtain an internal system clock rate; thus, a 10 MHz external crystal provided a 5 MHz internal system clock rate. However, a Series 6000 chip multiplies the external crystal's 10 MHz frequency by a value specified in the device's hardware template to specify the internal system clock rate; thus, a multiplier value of 1 yields a 10 MHz internal system clock rate, and a multiplier value of 8 yields an 80 MHz internal system clock rate. Valid multiplier values are  $\frac{1}{2}$ , 1, 2, 4, and 8. Note that for a multiplier value of  $\frac{1}{2}$ , the Series 6000 chip actually runs at 10 MHz (as if a multiplier of 1 were specified), but the Neuron system firmware schedules the application such that the application runs at 5 MHz.

Because the internal system clock rate is multiplied, rather than divided, a Series 6000 chip of a specific system clock rate can be considered to be approximately twice as fast as an equivalent Series 3100 chip (for example, an FT 6000 Smart Transceiver with a system clock of 20 MHz is approximately twice as fast as FT 3150 Smart Transceiver with an input clock of 20 MHz). The difference is approximate because a specific application on a Series 6000 device might run more than twice (or less than twice) as fast it would on a Series 3100 device due to variations in the hardware and software that are required by the Neuron architecture for Series 6000 devices.

Whenever the documentation for Series 6000 devices describes the system clock rate, it refers to the 10 MHz to 80 MHz internal system clock rate that is specified in the device's hardware template, *not* the 10 MHz frequency value of the external crystal.

---

## Reset Function

The reset function is a critical operation in any embedded microprocessor or microcontroller. For Series 6000 chips, the following mechanisms initiate a reset:

- The **RST**~ pin is pulled low and then released by an external switch or circuit.
- Device power up.
- Watchdog timeout occurs during application execution. The watchdog period is fixed at 840 ms (1.19 Hz) for all system clock rates. The actual timeout range is between 0.8 s and 1.7 s.
- Software command either from the application program or from the network.
- An exception trap (interrupt).
- The internal Low-Voltage Indicator (LVI) circuit detects a drop in the power supply below a set level. See the FT 6000 Free Topology Smart Transceiver data sheet or the Neuron 6000 Processor data sheet for internal LVI trip points.

During a reset, when the **RST**~ pin is in the low state, the Series 6000 chip pins go to the following states:

- Oscillator continues to run
- All processor functions stop
- The **SVC**~ pin goes to high impedance, with pullup
- I/O pins go to high impedance
- All memory interface pins go to high impedance

**Figure 28** illustrates the condition of the pins during reset and the Series 6000 chip initialization sequence after the **RST**~ pin is released.

When the **RST**~ pin is released back to a high state, the Series 6000 chip begins its initialization procedure starting at address 0x0001. The time it takes the Series 6000 chip to complete its initialization differs between the type of external serial memory used (SPI or I<sup>2</sup>C), different firmware versions that are being run, and the memory space used by the application (code and data); see *Reset Processes and Timing* for more information.

---

## **RST**~ Pin

The **RST**~ pin is both an input and an output. As an input, the **RST**~ pin is internally pulled high by a resistor. The **RST**~ pin becomes an output when any of the following events occur:

- Internal LVI detects a low voltage condition
- Software reset initialization
- Watchdog Timer event (times out)
- Traps

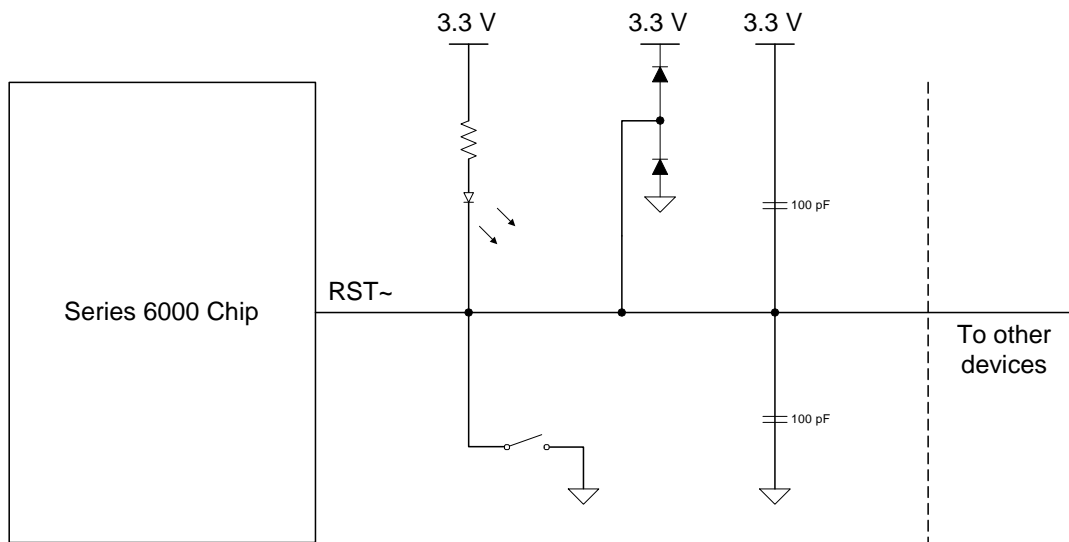
In some cases it is desirable to use the input capability of the **RST~** pin to allow other devices to reset the Series 6000 device. Examples of external devices that can be used for this purpose include push button switches, microcontrollers, and external low-voltage detectors.

**Important:** If the proper external reset circuitry is not used, the Series 6000 device can become applicationless or unconfigured. The applicationless or unconfigured state occurs when the checksum error verification routine detects corruption in memory which could have been falsely detected because of an improper reset sequence.

The following guidelines must be followed in order for the Series 6000 device's reset functions to operate reliably:

- Any device connected to the **RST~** pin must have an open-drain (or equivalent) output. If an external device were to actively drive the **RST~** pin high, contention between that device and the Series 6000 chip's internal circuitry could result in anomalous behavior ranging from applicationless errors to device failure.
- If any external devices are connected to the **RST~** pin of the Series 6000 chip, a capacitor should be connected between **RST~** and ground to provide noise immunity. The value of this capacitor should be at least 100 pF, and must not exceed 1000 pF. For even greater noise immunity, two capacitors (totaling  $\leq 1000$  pF) can be used, with one connected from the **RST~** pin to ground and the other from **RST~** to  $V_{DD33}$ . These capacitors should be located within 5 mm of the Series 6000 chip's **RST~** pin.
- During board level in-circuit testing (ICT), the **RST~** pin should be hard wired to ground through a "pogo pin".

**Figure 26** shows an example reset circuit.



**Figure 26.** Reset Circuit

## Reset Sources

Any of the following sources can cause a Series 6000 chip to reset:

- Device reset button press (or other hardware-driven assertion of the **RST~** pin)
- Power-on reset

- LVI circuit trip
- Watchdog timer expiration
- System-level traps
- Software-driven reset

The source of the last reset is saved in the Reset Cause register for diagnostic purposes.

## Power-Up and LVI

Both the power-on reset and low-voltage indications act as a single reset source. During power up sequences, the **RST~** pin is held low by the internal LVI until the power supply is stable. Likewise, when powering down, the **RST~** pin is driven low when the power supply goes below the Series 6000 chip's minimum operating voltage.

See the FT 6000 Free Topology Smart Transceiver data sheet or the Neuron 6000 Processor data sheet for internal LVI trip points.

## Watchdog Timer

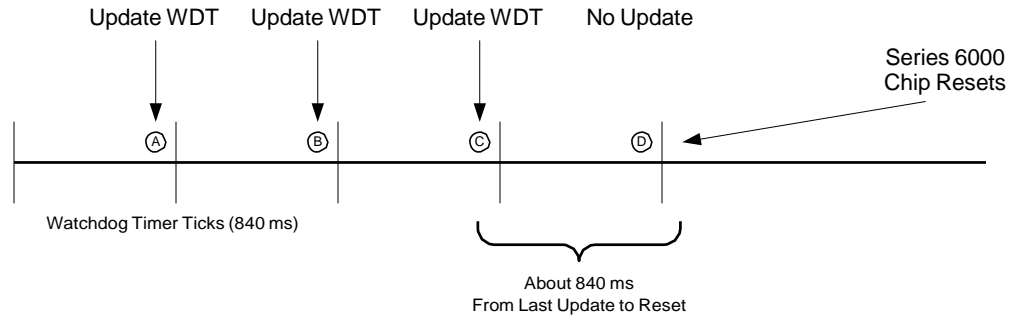
A Series 6000 chip is protected against malfunctioning software or memory faults by three watchdog timers, one for each processor that makes up the Neuron Core. If the application or the system software fails to update these timers periodically, the entire Series 6000 chip automatically resets. The Watchdog Timer circuit is always active and cannot be disabled.

The watchdog timer period is fixed at 840 ms (1.19 Hz) for all system clock rates. However, the actual timeout range is between 0.8 s and 1.7 s (see **Figure 27**). Each watchdog timer is a free-running timer, rather than a one-shot timer; that is, the timeout value is not set or reset each time the watchdog timer is updated. Updating the watchdog timer ensures that the expiration of the next timer tick does not cause a processor reset.

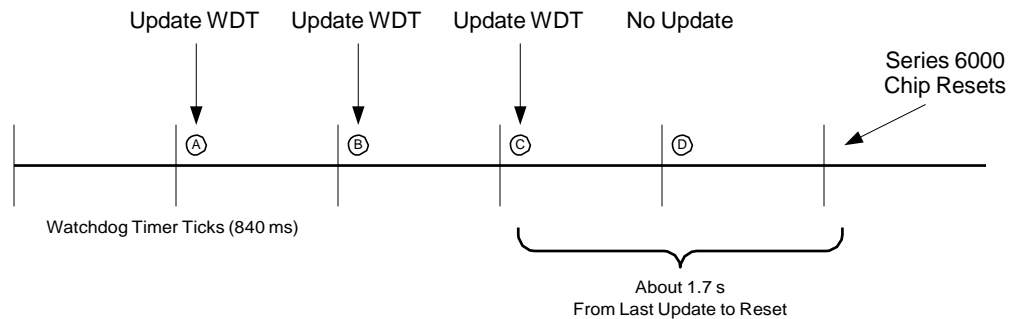
**Example 1:** The top example in **Figure 27** shows periodic WDT updates that occur just before the current WDT tick expires. The update at C ensures that the processor does not reset at the next WDT tick (which occurs immediately after the update at C). However, the missed update at D causes the processor to reset. The time between the last WDT update and the processor reset is about 840 ms.

**Example 2:** The bottom example in **Figure 27** shows periodic WDT updates that occur just after the current WDT tick has expired. The update at C ensures that the processor does not reset at the next WDT tick (which occurs almost a full WDT period after C). However, the missed update at D does not cause the processor to reset because the update at C ensured no reset. Instead, another WDT period elapses before the processor resets. The time between the last WDT update and the processor reset is about 1.7 s.

### EXAMPLE 1



### EXAMPLE 2



**Figure 27.** Series 6000 Watchdog Timer Period

Because your application typically has no knowledge of the current WDT tick, the application should update the WDT at regular intervals at least every 500 ms.

## Traps

The Neuron architecture provides a set of interrupts for various error conditions that allow the application or firmware to continue to run. A system-level trap is highest level of interrupt and is non-maskable, that is, it cannot be disabled. For each of these traps, the system firmware handles the interrupt, initiates a reset if necessary, and updates the error log for the chip. See *Processor Integrity* for additional information about these traps.

## Software-Controlled Reset

When the CPU watchdog timer expires, or a software command to reset occurs, the **RST~** pin is pulled low for 100  $\mu$ s.

---

### *Reset Processes and Timing*

During the reset period, the I/O pins are in a high-impedance state. The **SVC~** pin is high impedance during reset with an internal pull-up resistor.

Below is a summarization of the steps that a Series 6000 chip follows in preparing to execute application code. After the **RST~** pin is released, the Series 6000 chip performs hardware

and firmware initialization before executing application programs, including the following tasks:

- The ROM system image is copied from ROM to RAM (approximately 43 ms)
- The three base processors (NET, MAC, and APP) start running and the ROM system image starts running
- The ROM system image discovers the external FLASH boot loader image and loads it over the original ROM system image in RAM (approximately 260 ms). The three base processors restart and execute the boot loader.
- The FLASH boot loader adjusts the system clock to 80MHz and proceeds to load the FLASH system image over the boot loader image in RAM (approximately 90ms). The three base processors restart and execute the system image. The built-in self test (BIST) executes, testing the timer/counter logic, and the counter logic.
- The application data in FLASH is shadowed to RAM. This is a 3-step process (network image, NVM data, application code and constant data) which is at a minimum 10 ms with a maximum of about 100 ms based on the size of the NVM data and resident application data
- The **SVC~** pin is initialized, turning off the **SVC~** pin (high state)
- The system clock is set to the rate specified in the configuration data
- The extended RAM is initialized based on the information contained in the configuration data
- The communication port is initialized
- The state is initialized and a checksum is performed for the application
- The scheduler is initialized

Approximately 10  $\mu$ s after the **RST~** pin is released, the Neuron Core starts running. The **SVC~** pin oscillates between a solid low and a weak pullup. Once the network image is loaded the **SVC~** pin is configured to no longer oscillate. After approximately one second the **SVC~** pin is configured to reflect the application state of the device.

The period between the **RST~** pin being released and the start of the scheduler initialization task can be between 400 ms to 500 ms. Once the scheduler initialization task starts the network processor is available to accept incoming packets and the application may start.

If the BIST self-test fails, the device goes offline, the service LED comes on solid, and an error is logged in the device's status structure.

Self-test results are available in the first byte of RAM (0xE800), as listed in **Table 22**.

**Table 22.** Self-Test Results

Value	Description
0	No Failure
2	Timer/counter failure
3	Counter failure

The state initialization task determines if the external flash needs to be initialized; if it does need to be initialized, the state initialization task configures the Series 6000 chip with the default communication parameters and copies them to the external flash. This chip also enters the applicationless state.

The scheduler initialization task allows the application processor to perform application-related initialization:

- **State wait** — Wait for the device to leave the applicationless state.
- **Initialization step** — Execute initialization task, which is created by the compiler/linker to handle initialization of static variables and the timer/counters.
- **I/O pin initialization step** — Initialize I/O pins based on application definition. Prior to this point, I/O pins are high impedance.
- **State wait II** — Wait for the device to leave the unconfigured or hard-offline state. If waiting was required, a flag is set to indicate that the device should come up offline.
- **Parallel I/O synchronization** — Devices using parallel I/O attempt to execute the master/slave synchronization protocol.
- **Reset task** — Execute the application reset task (**when (reset){ }**).
- **Flag check** — If the offline flag was set, the chip goes offline and executes the offline task (**when(offline){ }**). If the BIST flag indicated a failure, the SERVICE LED is turned on and the offline task is executed. Otherwise, the scheduler starts its normal task scheduling loop.

The amount of time required to perform these steps depends on a variety of factors, including: Series 6000 chip model; configured system clock rate; whether the device is applicationless, configured, or unconfigured; amount of configured extended RAM; and application initialization.

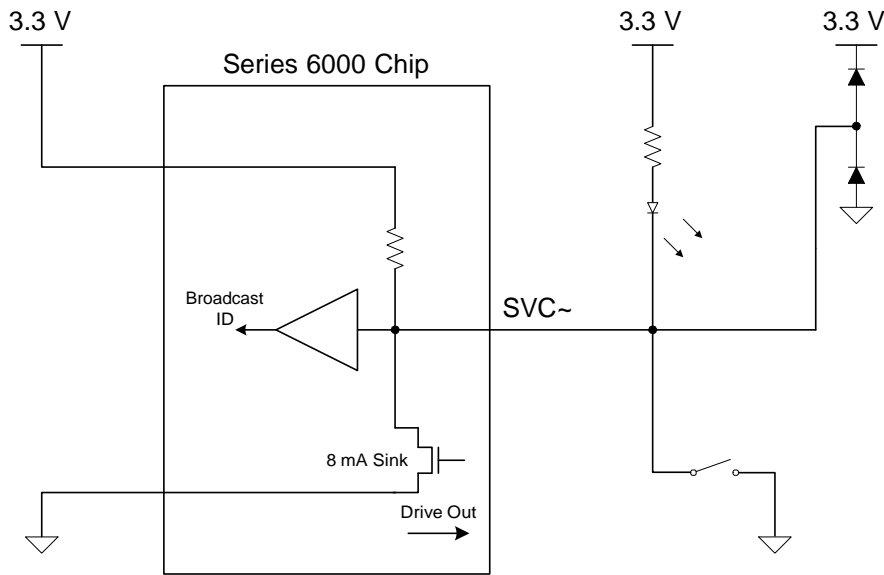


## SVC~ Pin

The SVC~ pin alternates between input and open-drain output at a 76 Hz rate with a 50% duty cycle. When it is an output, it can sync up to 8 mA for use in driving an LED. When it is used exclusively as an input, it uses an optional external pull-up to bring the input to an inactive-high state.

Under control of the Neuron firmware, this pin is used during configuration, installation, and maintenance of the device containing the Series 6000 chip. The firmware flashes the LED at a 1/2 Hz rate when the Series 6000 chip has not been configured with network address information. Grounding the SVC~ pin causes the Series 6000 chip to transmit a network management message containing its unique 48-bit IEEE MACID and the application's program ID. This information can then be used by a network management tool to install and configure the device. **Table 24** lists the state of the Service LED for various device states. The Neuron firmware samples the SVC~ pin whenever it is not actively driving the pin low.

A typical circuit for the SVC~ pin LED and push-button is shown in **Figure 29**. During reset, the SVC~ pin is pulled high by its internal pull-up resistor.



**Figure 28.** SVC~ Pin Circuit

**Table 23.** Service LED Behavior during Different States

Device State	State Code	Service LED
Applicationless and Unconfigured	3	On
Unconfigured (but with an Application)	2	Flashing

Device State	State Code	Service LED
Configured, Hard Offline	6	Off
Configured	4	Off
Defective External Memory	—	On

The **SVC~** pin is active low, and the service pin message is sent once per **SVC~** pin transition. The service pin message goes into the next available non-priority output network buffer.

---

## Integrity Mechanisms

The Neuron architecture for a Series 6000 chip includes mechanisms for maintaining system integrity by ensuring processor integrity and application integrity.

---

### *Processor Integrity*

To maintain processor integrity while an application is running, the Neuron architecture provides a set of interrupts for various error conditions that allow the application or firmware to continue to run. There are certain error conditions that, without interrupt support, would cause the processor to stop execution and possibly cause a reset of the device. A Series 6000 chip handles the following error conditions with system-level traps:

- Watchdog timer timeout
- Memory-protection violations for writing to system image
- Stack exceptions, including underflow, overflow, and collision conditions for the data stack, return stack, and ISR stack
- Execution of an illegal Neuron assembly language opcode
- Execution of the Neuron assembly language **HALT** instruction

A system-level trap is highest level of interrupt and is non-maskable, that is, it cannot be disabled. For each of these traps, the system firmware handles the interrupt, initiates a reset if necessary, and updates the error log for the chip.

---

### *System Firmware Image*

The 16 KB of RAM from memory address 0x0000 to address 0x3FFF holds the executing copy of the Neuron firmware that is copied from external flash memory. This memory area is write protected so that an application program cannot alter the system firmware. Attempted writes to this memory area trigger a memory-protection violation trap, which causes the chip to reset.

---

### *Application Integrity Using Checksums*

To ensure application integrity, the Neuron firmware maintains a checksum of the application image. The checksum is a single byte, and is the two's complement of the sum of all bytes that it covers. The checksums is verified during reset processing, and also on a continual basis through a background diagnostic process.

The application image checksum covers the application code in both the Application Resident Code and Constant Data areas. The default behavior is that an application checksum error causes the device to go to the applicationless state. Application read/write data residing the Application NVM area is not checksummed.

No checksum is computed if the device is in the applicationless state.

Upon detecting a checksum error, the reset process forces the appropriate state and logs an error in the error log. A checksum must fail twice during reset processing for it to be considered in error. If the application checksum is bad, and no application recovery options are set, an application checksum error is logged, and the device state is changed to applicationless.



# 3

## Hardware Design Considerations

This chapter describes PCB layout guidelines for Series 6000 chips, and describes how to use an FT 6000 Smart Transceiver with a host microprocessor.

---

## PC Board Layout Guidelines

Electrostatic discharge (ESD) and electromagnetic interference (EMI) are two of the most important design considerations when laying out the PCB for a device. See Chapter 4, *Design and Test for Electromagnetic Compatibility*, for more information about ESD and EMI design considerations.

Tolerance of ESD and other types of network transients requires careful layout for power, ground, and other device circuitry. In general, ESD currents return to Earth ground or to other nearby metal structures. The device's ground scheme must be able to pass this ESD current between the network connection and the device's external ground connection without generating significant voltage gradients across the device's PCB. The low-inductance star-ground configuration accomplishes this task. The star-ground configuration conducts transients out of the device with minimal disruption to other function blocks.

The following list describes the general features of a careful PCB design layout for FT 6000 Smart Transceivers and Neuron 6000 Processors:

**Star-Ground Configuration:** The various blocks of the device that directly interface with off-board connections (the network, any external I/O, and the power supply cable) should be arranged so that the connections are together along one edge of the PCB. This arrangement allows any transient current that comes in by one connection to flow back out of the device by one of the other connections.

If connection is made between the PCB ground and a metal enclosure, that connection should be made using a low-inductance connection (like a short standoff) in the center of the star ground. The center of the star ground is anywhere within the common ground area around the off-board connections.

For a 4-layer PCB, the ground plane serves to distribute ground from the center of the star ground out to the various function blocks in the floorplan. For a 2-layer PCB, ground pours should be placed on the bottom layer (and also on the top layer where possible) in order to connect the grounds of the various function blocks to the center of the star ground.

**EMC Keepout Area:** The area around the FT 6000 Smart Transceiver network connection traces and components should be considered "ESD Hot", and other traces and components (and inner planes) should be kept at least 3.5 mm (0.14 inch) away from the network connection traces and components to prevent ESD arc-overs. In addition, digital signal traces (and other high-speed switching signal traces) should be routed around this keep out area. If you route signals under this area, be sure to add a return plane (ground or power) between the network connection trace layer and the other signal layers.

The PCB layout should be designed so that substantial ESD hits from the network discharge directly to the star-ground center point. Placing a 470 V MOV near the network connector and near the center of the star ground shunts the majority of the network ESD hit energy directly to the star center, which helps to limit the transient current that passes through the FT-X3 transformer.

The PCB layer ground at the center of the star-ground should have a low-inductance return to an external metal package if there is one. If there is no metal package, then this ground area should connect to the ground areas near the power supply connector and the external I/O connectors, as applicable. The transient current that is clamped by the MOV should be routed off of the PCB as directly as possible, without any

opportunity to run through the Series 6000 chip itself, and any other circuitry, such as a host microprocessor.

**Transceiver-Side Clamp Diodes:** Two diodes clamp the FT 6000 Smart Transceiver side of the FT-X3 transformer between  $V_{DD33}$  and ground. The  $V_{DD33}$  and ground connections between the diodes and the transformer must be made with short, wide traces using a low inductance technique, which ensures that the secondary transient energy (remaining after the primary discharge through the MOV) does not disrupt the FT Smart Transceiver. The  $V_{DD33}$  and ground connections of the diodes are designed to return transient currents to the star-ground center point.

**Network-Side Clamp Diodes:** Four diodes clamp the network side of the FT-X3 transformer to ground through the MOV during ESD and surge transients. The connections between the diodes and the MOV must be made using low inductance traces, which ensures that secondary transient energy remaining after the primary discharge through the MOV does not disrupt the FT Smart Transceiver. The connection of the MOV is designed to return transient currents to the star-ground center point.

**Ground Return for a Series 6000 Chip:** The FT 6000 Smart Transceiver has internal protection circuitry built into its NETP and NETN pins (the CP0 and CP1 pins for a Neuron 6000 Processor). When an ESD or surge transient comes in from the network, the portion of the transient that makes it to the Series 6000 chip is clamped to the chip's  $V_{DD33}$  power pins and ground pins.  $V_{DD33}$  is bypassed to ground at the Series 6000 chip, so the transient current returns to the center of the star ground through the ground layer for a 4-layer PCB, or the ground pours for a 2-layer PCB. Be sure to provide a short and wide ground path from the Series 6000 chip back to the center of the star ground.

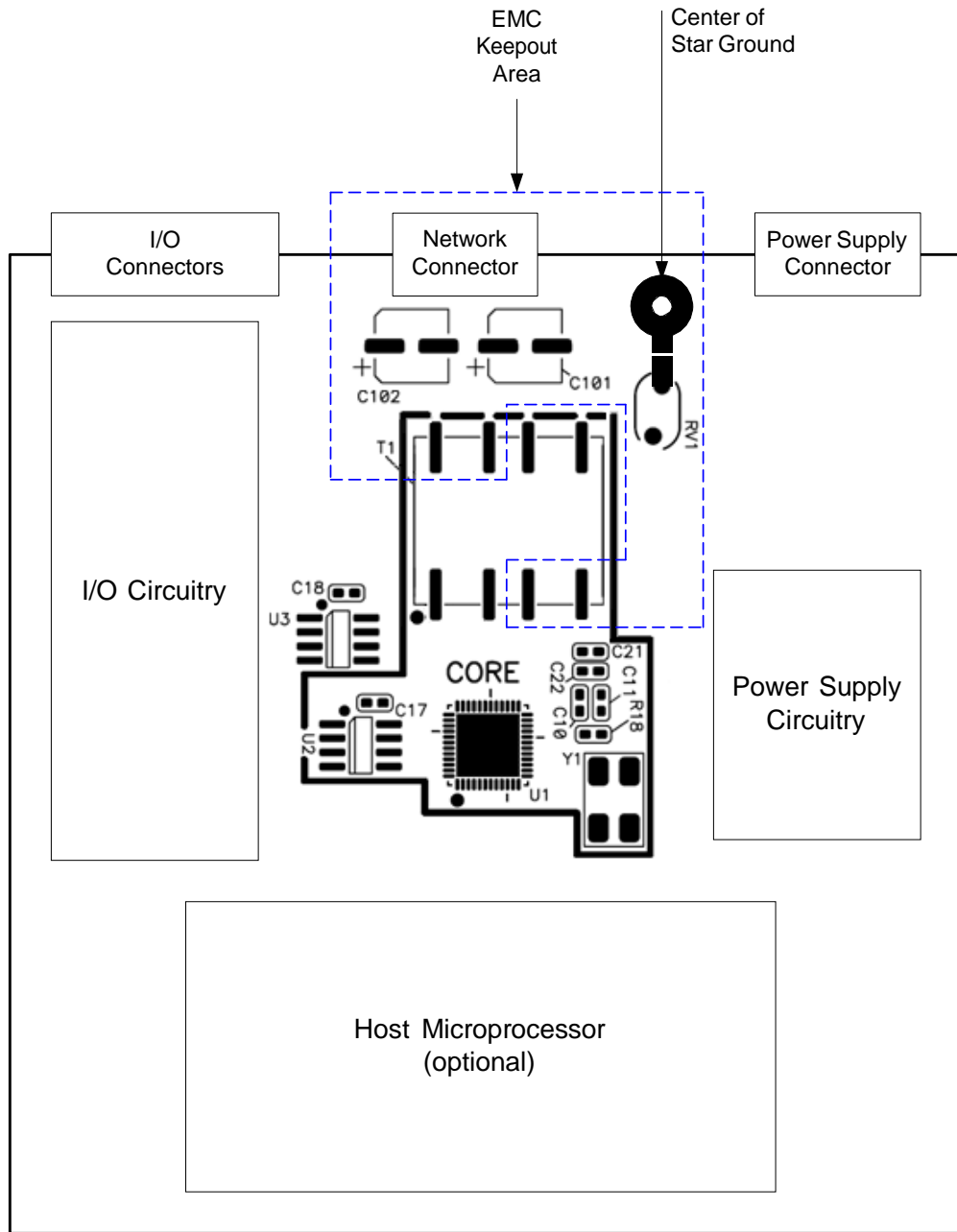
**Ground Planes:** As ground is routed from the center of the star out to the function blocks on the board, planes or very wide traces should be used to lower the inductance (and therefore the impedance) of the ground distribution system.

**$V_{DD33}$  Decoupling Capacitors:** A good rule of thumb is to provide at least one  $V_{DD33}$  decoupling capacitor to ground for each  $V_{DD33}$  power pin on an IC in the design. For SMT devices like a Series 6000 chip, each decoupling capacitor should be placed on the top layer with the chip, and placed as close as possible to the chip to minimize the length of  $V_{DD33}$  trace between the capacitor and the chip's  $V_{DD33}$  pad. The ground end of the capacitor should have a wide, short connection to ground. Keeping these connections short and wide reduces their inductance, which improves the effectiveness of the decoupling. SMT capacitors with a value of 0.1  $\mu\text{F}$  work well for decoupling, as long as the connections are kept very short. If you use ESD clamp diodes between  $V_{DD33}$  and ground on I/Os, there should generally be at least one decoupling capacitor for every two diode clamps, placed very close to those diode clamps.

**Host Microprocessor Kept Away From Network Connection:** The (optional) host microprocessor (for a ShortStack device or an FTXL device) is a potential source of digital noise that could cause radiated EMI problems if that noise is allowed to couple onto the external network, power, or I/O wiring. To help prevent this coupling, the host microprocessor and any other noisy digital circuitry should be kept away from the network side of the Series 6000 chip. For example, place the host microprocessor on the opposite side of the Series 6000 chip from the network, power, and I/O connectors.

**Figure 30** shows a portion of the top layer of a 4-layer printed circuit board (PCB) layout for the FT 6000 Smart Transceiver, along with the other building blocks of a PCB design. A PCB layout for a Neuron 6000 Processor would be similar to that shown in **Figure 30**.

Variations on this suggested PCB layout design are possible as long as the general principles discussed in this chapter are followed. Through-hole capacitors and diodes can be used, but SMT components are generally superior because of their lower series inductance.



**Figure 29.** Example PCB Layout Design for an FT 6000 Smart Transceiver

For a development and test board, you can use a socket for the Neuron 6000 Processor or FT 6000 Smart Transceiver, such as the 48LQ50S17070 open-top dual latch QFN socket from Plastronics Socket Company, Inc., or the S-MLF-00-048-A1 open-top QFN/MLF socket from Emulation Technology, Inc.



# 4

## **Design and Test for Electromagnetic Compatibility**

This chapter describes electromagnetic compatibility design considerations for Series 6000 devices and the tests that you perform to ensure immunity.

---

## Overview

A product that is designed for electromagnetic compatibility (EMC) must be able to pass rigorous tests for immunity to external interference and demonstrate low electromagnetic interference (EMI) emissions. If the product will be sold in the European Union (EU), the product must demonstrate appropriate EMC levels to pass European Conformité Européene<sup>4</sup> (CE) Marking tests. Even if the product will not be sold in the EU, immunity testing helps you to design a better, more robust product.

Echelon has performed immunity tests for CE Marking on Series 6000 devices, and has also performed additional tests to ensure immunity and low emissions. Specifically, Echelon has performed the following immunity tests:

- Electrostatic discharge (ESD) testing (both air and contact discharge) for compliance with Comité Européen de Normalisation<sup>5</sup> (CEN), standard EN 61000-4-2
- Radiated radio frequency (RF) immunity testing for compliance with CEN standard EN 61000-4-3
- Burst testing for compliance with CEN standard EN 61000-4-4
- Surge testing for compliance with CEN standard EN 61000-4-5
- Conducted RF Immunity testing for compliance with CEN standard EN 61000-4-6

*Summary and Testing Results* summarizes the results of Echelon's testing for Series 6000 devices.

You need to perform your own immunity testing for Series 6000 devices that you design and build.

The test results for each of the CEN standard EN 61000-4-x tests are interpreted within the scope of the product's specifications and standard operating conditions. A product's test results fall into one of the following categories, which are referred to as "performance criteria":

1. Normal product performance within specified limits
2. Temporary degradation or loss of function, or performance, that is self-recoverable
3. Temporary degradation or loss of function, or performance, that requires operator intervention to reset the system
4. Degradation or loss of function that is not recoverable

For example, within a LONWORKS network, losing one network packet because of an ESD or surge hit likely meets category 1 because the Series 6000 chip resends network data that is not acknowledged as received.

For more information about the CEN standard tests and to purchase copies of the standards documents, go to the Information Handling Services (IHS) Global page: [global.ihs.com](http://global.ihs.com).

---

<sup>4</sup> European Conformity

<sup>5</sup> European Committee for Standardization

---

## Achieving High Immunity

Achieving good immunity to ESD and other types of network transients requires good layout of the power, ground, and other device circuitry. In general, an ESD current will return to Earth ground or to other nearby metal structures. The device's ground scheme must be able to pass this ESD current between the network connection and the device's external ground connection without generating significant voltage gradients across the device.

To achieve high immunity, ensure that your design conforms to the following general guidelines:

- Use a star-ground configuration for your device layout
- Limit entry points in the device for ESD current
- Provide ground guarding for switching power supply control loops
- Provide good decoupling for  $V_{DD33}$  and  $V_{DD18}$  inputs
- Maintain separation between digital circuitry and cabling for the network and power

In a star-ground configuration, the power supply, network coupling circuit, and any I/O circuitry are distributed on the PCB in the form of a star, with the respective connectors and any chassis ground connections forming the center of the star. The host microprocessor and other sensitive circuitry should be located away from the center of the star. The goal of the star-ground configuration is to conduct transients that enter the device on one cable out of the device through the other cables, with minimal disruption to other functional areas of the device. If the device has a metal chassis, ESD and other transients generally return to that chassis by way of the star-ground center point. If the device's logic ground is connected to this chassis ground, you should only connect it at this single point, with a short standoff, in the center of the star. Keep noisy digital lines (such as host microprocessor memory array lines) away from the metal enclosure walls. If a device is housed in a plastic enclosure and is powered with an isolating transformer, an explicit Earth ground or chassis ground might not be available. In this case, it is still important for the network connector and power supply connector to be located near the center of the star.

Switching power supply control loops can pick up radio-frequency (RF) noise and rectify it. RF immunity depends on limiting the pickup of such RF noise, so you need to provide sufficient ground guarding for the switching power supply control loops.

To provide good decoupling for  $V_{DD33}$  and  $V_{DD18}$  inputs, you should distribute  $V_{DD33}$  and  $V_{DD18}$  through low inductance traces and planes in the same manner as ground. All of the ground pins on an FT 6000 Smart Transceiver or Neuron 6000 Processor should be connected with either a ground plane (for PCBs with at least 4 layers) or a ground pad directly underneath the FT 6000 Smart Transceiver or Neuron 6000 Processor on the bottom of the board (for PCBs with 2 layers). Place one SMT decoupling capacitor per power pin between the FT 6000 Smart Transceiver or Neuron 6000 Processor and ground. Place each decoupling capacitor on the top side of the PCB, with the connection to its  $V_{DD33}$  or  $V_{DD18}$  pin as short as possible.

Maintaining separation between digital circuitry and cabling for the network and power limits RF crosstalk to any traces associated with the network or power supply (and any I/O lines that leave the device).

---

## Electrostatic Discharge

Electronic systems in industrial and commercial environments frequently encounter electrostatic discharge (ESD). An ESD event is a momentary electric current that flows

between electrically charged objects at different voltage potentials (one of which can be ground). The most common form of ESD is an electric spark, but not all ESD hits are accompanied by a spark.

A reliable system design must consider the effects of ESD, and take steps to protect sensitive components. Static discharges occur frequently in low-humidity environments when human operators touch electronic equipment. Keyboards, connectors, and enclosures can also provide paths for static discharges to reach ESD-sensitive components. In addition, the European Community has adopted requirements for ESD testing.

There are two general approaches to minimizing the effects of ESD for an electronic product:

- Seal the product to prevent static discharges from reaching sensitive circuits inside the package.
- Design the grounding of the product so that ESD hits to user-accessible metal parts can be shunted around sensitive circuitry.

Because a LONWORKS network connector is likely to be user-accessible, it is generally not possible to seal Series 6000 devices completely. However, the product's package should be designed to minimize the possibility of an ESD hit arcing into the device's circuit board. If the product's package is made of plastic, then the PCB should be supported within the package so that unprotected circuitry on the PCB is not adjacent to any seams in the package. The PCB should not touch the plastic of an enclosure near a seam, because a static discharge can creep along the surface of the plastic, through the seam, and arc onto the PCB.

After an ESD hit arcs into the product, the current from the discharge flows through all possible paths back to Earth ground. The grounding of the PCB, and the protection of user-accessible circuitry, must allow these ESD return currents to flow back to Earth ground without disrupting normal circuit operation of the Series 6000 chip, its host microprocessor (if any), or other device circuitry. Generally, this means that you should ensure that the ESD currents are shunted to the center of a star ground configuration (as described in *Achieving High Immunity*), and then out to the product's chassis or Earth ground connection. If the device floats with respect to Earth ground, the ESD current can return capacitively to Earth by the network wire, the power supply wires, and the PCB ground plane.

Testing for ESD to comply with the EN 61000-4-2 ESD immunity test standard is performed on a metal test table using an ESD transient generator. Level 4 testing involves injecting up to  $\pm 8$  kV contact discharges and up to  $\pm 15$  kV air discharges into the product under test. Depending on the product design, you can inject the discharges at the network connector, power connector, or other user-accessible areas. During the test, the device should continue to operate normally, with occasional packet loss due to the ESD hits.

---

## Electromagnetic Interference

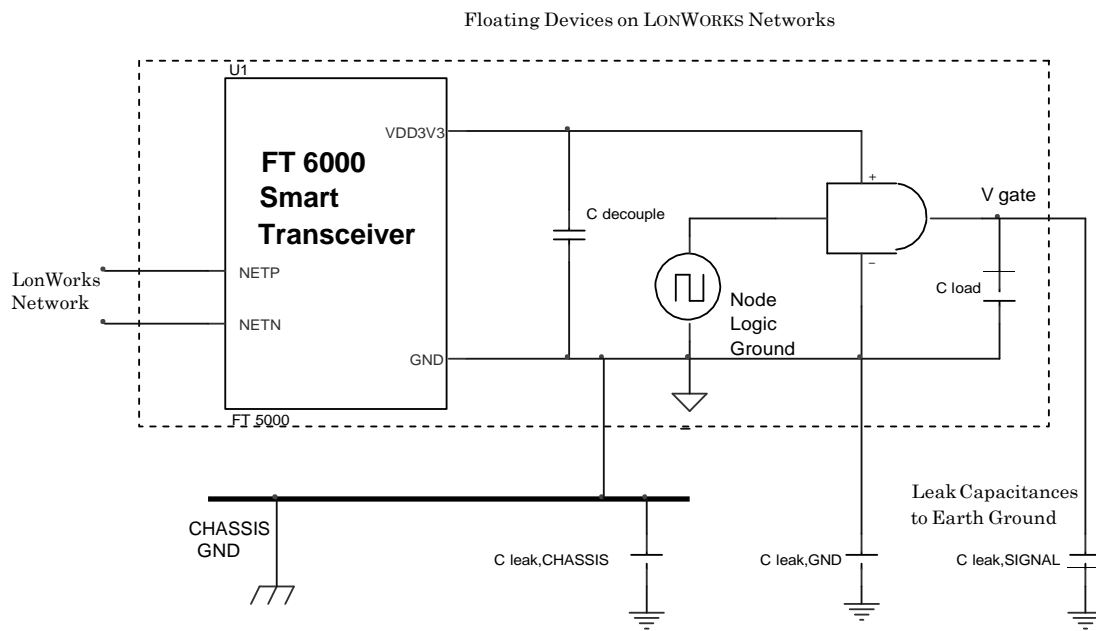
The high-speed digital signals that are associated with microcontroller designs can generate unintentional electromagnetic interference (EMI). This interference is emitted by electrical circuits that carry rapidly changing signals that generate RF currents that can cause unwanted signals to be induced in other circuits. These unwanted signals can interrupt or degrade the effective performance of those other circuits.

Products that use an FT 6000 Smart Transceiver or Neuron 6000 Processor will generally need to demonstrate compliance with EMI limits enforced by various regulatory agencies. In the USA, the Federal Communications Commission (FCC) requires that industrial products comply with Title 47 of the Code of Federal Regulations (CFR) Part 15, Subpart A, and it requires that products which can be used in residential environments comply with Subpart

B. The European comité européen de normalisation electrotechnique<sup>6</sup> (CENELEC) EN 55022 standard and the international comité international spécial des perturbations radioélectriques<sup>7</sup> (CISPR) 22 standard both require similar compliance, and most countries throughout the world require compliance with similar regulations.

A typical Series 6000 device has several digital I/O signals that switch in the kHz to MHz range. These signals generate voltage noise near the signal traces, and also generate current noise in the signal traces and power supply traces. The goal of good device design is to keep this voltage and current noise from coupling out of the product's package. Thus, careful PCB layout can ensure that a Series 6000 device achieves the desired low level of EMI emissions.

It is important to minimize the leakage capacitance from circuit traces in the device to any external pieces of metal near the device, because this capacitance provides a path for the digital noise to couple out of the product's package. Figure 31 shows the leakage capacitances to Earth ground from a device's logic ground ( $C_{leak,GND}$ ) and from a digital signal line in the device ( $C_{leak,SIGNAL}$ ).



**Figure 31.** Parasitic Leakage Capacitances to Earth Ground

If the Series 6000 device is housed inside a metal chassis, that chassis likely has the largest leakage capacitance to other nearby pieces of metal. If the device is housed inside a plastic package, use PCB ground guarding to minimize  $C_{leak,SIGNAL}$ . Effective guarding of digital traces with logic ground reduces  $C_{leak,SIGNAL}$  significantly, which reduces the level of common-mode RF currents driven onto the network cable.

For a device mounted near a piece of metal, especially metal that is Earth grounded, any leakage capacitance from fast signal lines to that external metal provides a path for RF currents to flow. When  $V_{gate}$  is pulled down to logic ground, the voltage of logic ground with respect to Earth ground increases slightly. When  $V_{gate}$  is pulled up to  $V_{DD33}$ , logic ground is pushed down slightly with respect to Earth ground.

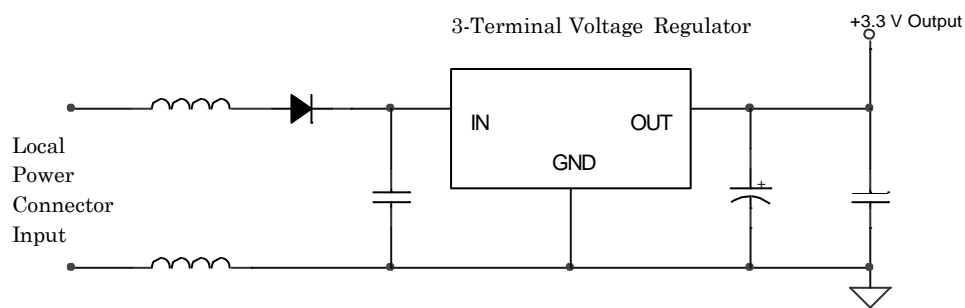
<sup>6</sup> European Committee for Electrotechnical Standardization

<sup>7</sup> International Special Committee on Radio Interference

As  $C_{\text{leak,SIGNAL}}$  increases, a larger current flows during  $V_{\text{gate}}$  transitions, and more common-mode RF current couples onto the network twisted pair. This common-mode RF current can generate EMI in the 30-500 MHz frequency range, well in excess of CFR Part 15 Subpart B or CISPR 22 Class B levels, even when the capacitance of  $C_{\text{leak,SIGNAL}}$  from a clock line to Earth ground is less than 1 pF. Thus, it is essential to guard clock lines (and keep them on the top side of the PCB, if possible) for meeting Subpart B limits.

By using 0.1  $\mu\text{F}$  or 0.01  $\mu\text{F}$  decoupling capacitors at each digital IC power pin, you can reduce  $V_{\text{DD33}}$  and logic ground noise. You can then use logic ground as a ground shield for other noisy digital signals and clock lines.

In addition, some amount of filtering might also be required on a Series 6000 device's power supply input, depending on the level of noise generated by the application circuitry. A good way to achieve this filtering is to place ferrite chokes in series with the power input traces adjacent to the power connector. Figure 32 shows a typical power supply circuit illustrating the placement of these ferrite chokes.



**Figure 32.** Power Supply Input Filtering Using Ferrite Chokes

Testing for EMI to comply with the CISPR 22 Radio Disturbance Characteristics test standard takes two forms:

- Radiated EMI testing checks for RF noise that radiates from network and power cables (or from inside the device)
- Conducted EMI testing checks for RF noise that radiates from the power supply connection to the AC mains

Compliance with the CISPR 22 Class A standard is required for industrial products, and compliance with the Class B standard is required for products that can be used in residential environments.

The following general rules and guidelines summarize EMI design considerations:

- The faster the system clock speed for a Series 6000 device, the higher the level of EMI.
- Better  $V_{\text{DD3}}$  decoupling quiets RF noise at the sources (the digital ICs), which lowers radiated EMI.
- A four-layer PCB generates less EMI than a two-layer PCB because the extra layers provide better  $V_{\text{DD3}}$  decoupling and more effective logic ground guarding.

---

## Radiated and Conducted Immunity

The EN 61000-4-3 RF Susceptibility and EN 61000-4-6 Conducted RF Immunity tests ensure that a device's operation is not impaired by strong electromagnetic fields, such as those generated near cellular phones and portable radios.

The EN 61000-4-3 RF Susceptibility test is generally performed in an RF-shielded anechoic chamber with high-power transmitter-driven antennas aimed at the equipment under test (EUT). During the EN 61000-4-3 RF Susceptibility test, the RF signal generator is set to an amplitude modulation (AM) depth of 80% at 1 kHz, and the frequency is slowly swept from 30 MHz to 1 GHz. With this condition, there are three levels of testing:

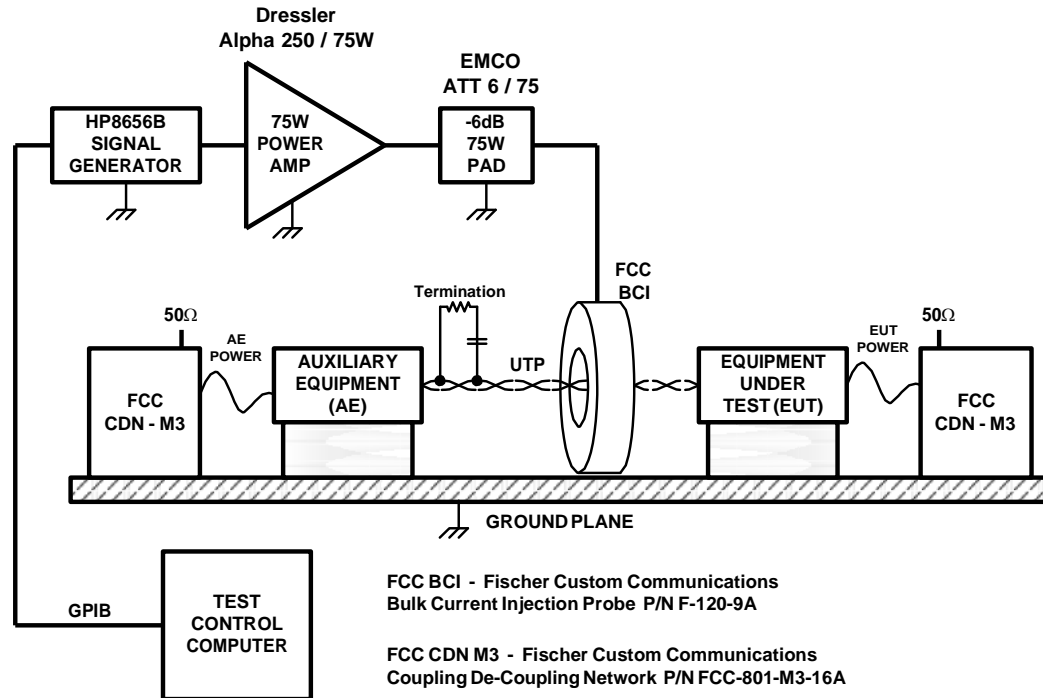
- Level 1 subjects the EUT to a 1 V/m field strength
- Level 2, which represents a moderate electromagnetic radiation environment, subjects the EUT to a 3 V/m field strength
- Level 3, which represents a severe electromagnetic radiation environment, subjects the EUT to a 10 V/m field strength

During the EN 61000-4-6 Conducted RF Immunity test, the RF signal generator is set to an AM depth of 80% at 1 kHz, and the frequency is slowly swept from 150 kHz to 80 MHz. With this condition, there are three levels of testing:

- Level 1 injects a common-mode voltage on the EUT's network cable of 1 V<sub>RMS</sub> (5 V<sub>P-P</sub> including the 80% AM)
- Level 2, which represents a light industrial environment, injects a common-mode voltage on the EUT's network cable of 3 V<sub>RMS</sub> (15.3 V<sub>P-P</sub> including the 80% AM)
- Level 3, which represents a harsh industrial environment, injects a common-mode voltage on the EUT's network cable of 10 V<sub>RMS</sub> (50.9 V<sub>P-P</sub> including the 80% AM)

For twisted-pair networks, the preferred test method is the Current Injection method, also called the Bulk Current Injection (BCI) method. A current clamp injects common-mode noise onto the twisted-pair communication cable, and both the auxiliary equipment and the EUT experience similar common-mode noise at their network connections. Even when this wiring passes through a coupling-decoupling network, the RF noise that is present during the test can disrupt wired communication between the auxiliary equipment and an external control PC. Thus, the auxiliary equipment should provide a visual indication of a pass/fail result during the test, rather than requiring a wired connection to a computer to monitor the result.

Figure 33 shows a typical setup for EN 61000-4-6 testing of a Series 6000 device with unshielded twisted-pair (UTP) network wire.



**Figure 33.** Typical EN 61000-4-6 Test Setup for Unshielded Twisted-Pair (UTP) Wires

For the EN 61000-4-6 tests, the EUT is placed on a 10 cm high, non-conducting support on top of a metal ground plane. If the chassis of the EUT is connected to Earth ground in typical installations, for the test it should be connected directly to the metal ground plane with a short wire. If the EUT is left floating in normal use, there should be no connection between the EUT and Earth ground for the EN 61000-4-6 tests.

Power connections for the auxiliary equipment and EUT should be routed through suitable decoupling devices, such as non-driven M3 “coupling-decoupling” network (CDN) devices. During the network immunity tests, any I/O lines that come out of the auxiliary equipment or the EUT should also pass through a decoupling network. The objective of the BCI current clamp is to drive the large common-mode noise signal into the network cable of the EUT. The M3 CDNs ensure that the power supply inputs to the auxiliary equipment and EUT are not an RF return path.

For shielded twisted-pair (STP) networks, the BCI current clamp injects common-mode noise into the STP cable. The cable shield should be connected to Earth ground with a parallel resistor and capacitor as shown in Figure 34. The resistor is generally 470 kΩ, 0.25 W, 5%. The capacitor is generally 0.1 μF, 10%, metal polyester, with a voltage rating of 100 VDC or higher.



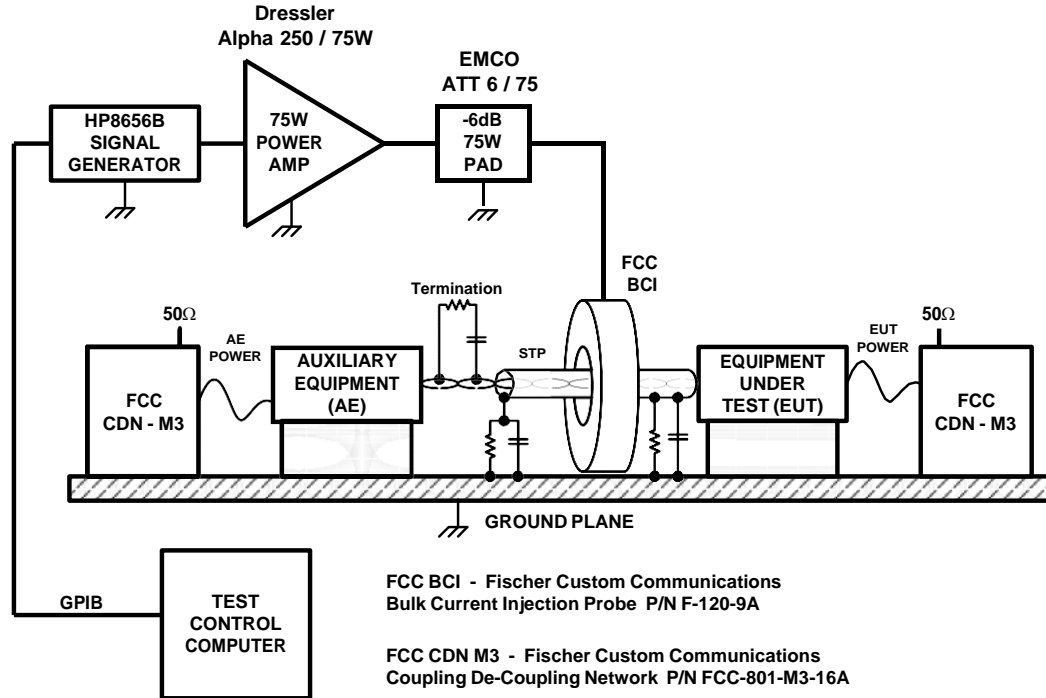


Figure 34. Typical EN 61000-4-6 Test Setup for Shielded Twisted-Pair (STP) Wires

## Surge and Burst

For the purposes of EMC testing, a surge is a transient overvoltage of several kV with a rise time that is measured in microseconds or nanoseconds, and with a duration that is measured in microseconds. Compared with fast transient bursts and ESD, surges are relatively slow, but also long lived.

A surge is created by a switching event or insulation fault in the AC power distribution network, or by the switching of a reactive load (such as an electric motor). A surge can also be caused by lightning, but EN 61000-4-5 only indirectly addresses the effects of lightning.

EN 61000-4-5 Surge testing is performed on a non-conducting table using specialized surge generation equipment. The surges are injected directly into the network wiring (in a common-mode fashion) or into the power supply cable through a coupling circuit. During the test, the device should continue to operate normally, with occasional packet loss due to the surges.

There are three levels of network testing that are relevant to Series 6000 devices:

- Level 2 conductively couples a  $\pm 1$  kV surge into the network
- Level 3 conductively couples a  $\pm 2$  kV surge into the network
- Level “X” conductively couples a user-defined surge voltage into the network

EN 61000-4-4 Burst testing of the network cable is performed on a non-conducting table, with 1 meter of the network cable clamped in a high-voltage burst generation apparatus. The test capacitively injects high voltage bursts of noise into the network cable. The test injects three bursts onto the network cable each second. During the test, the device should continue to operate normally, with occasional packet loss due to the bursts.

There are two levels of network testing that are relevant to Series 6000 devices:

- Level 3, which represents a typical industrial environment, injects  $\pm 1$  kV bursts continuously for 60 seconds
- Level 4 which represents a severe industrial environment, injects  $\pm 2$  kV bursts continuously for 60 seconds

In addition, burst testing is performed on the power supply input cable. For Series 6000 devices, the following levels of power supply input testing are relevant:

- Level 3, which represents a typical industrial environment, injects  $\pm 2$  kV bursts continuously for 60 seconds
- Level 4 which represents a severe industrial environment, injects  $\pm 4$  kV bursts continuously for 60 seconds

---

## Lightning Protection

Protection against lightning is required when designing control networks that run outside of buildings.

---

### *Building Entrance Protection*

Echelon recommends using shielded twisted-pair wire for all networks, or portions of networks, that are run outside of buildings or grounded structures. The shield, as well as the two network lines, should be connected to Earth ground through Data Line Lightning/Surge arresters at each building entry point. This connection conducts excessive energy surges or lightning strike energy directly to Earth and prevents their entry inside the building through the network shield or data line conductors. Therefore, three arresters should be used at each building entrance for shielded twisted-pair wiring.

---

### *Network Line Protection*

The arresters used on the network data lines must be of the Gas Discharge type. The intrinsically low capacitance to ground of these devices, typically less than 5 pF, minimizes the corruption of any data signals. Due to their low capacitance construction, the use of Gas Discharge devices does not alter the maximum number of devices allowed per network segment.

**Important:** MOV and TVS protection devices must not be used on the network data lines because of their much higher capacitance ( $>200$  pF) and potentially poor differential capacitance matching. These devices can corrupt, and possibly prevent, network communication between devices.

---

### *Shield Protection*

Gas Discharge, MOV, or TVS devices can be used for the **shield-to-ground** protection. MOV and TVS devices should not be used to protect the network data lines.

---

### *Suggested Gas Discharge Arresters*

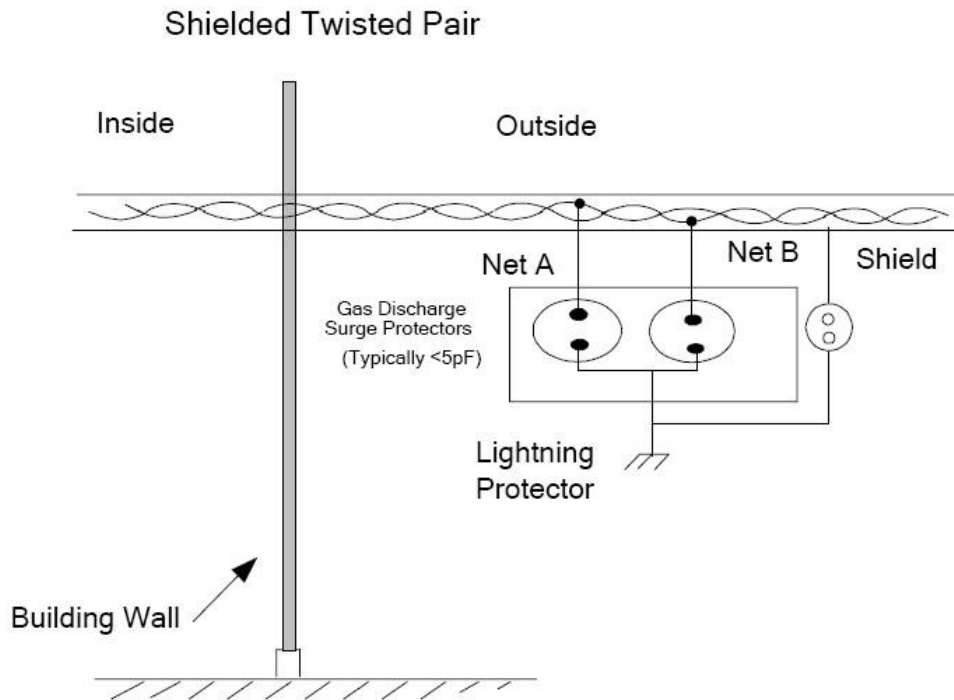
Three-electrode device configurations are suggested for the data network lines, because they require the use of only one physical device to protect both lines. The network lines should be connected to the two outside ends of the arrester, while the middle terminal must be

connected to a stable Earth ground. Alternatively, two each of two-electrode configurations can be used (contact manufacturer for details). Table 25 provides a list of three-electrode Gas Discharge device manufacturers.

**Table 25.** Manufactures of Suggested Gas Discharge Arresters

Vendor and Configuration	Series	Voltage
Sankosha, 3 Electrode <a href="http://www.sankosha-usa.com/arresters.asp?id=2">www.sankosha-usa.com/arresters.asp?id=2</a>	3H or 3P	90 VDC
Citel, 3 Electrode <a href="http://www.citelprotection.com/citel/gas_cover.htm">www.citelprotection.com/citel/gas_cover.htm</a>	BT, BTR, or BTS	90 VDC
Littelfuse, 3 Electrode <a href="http://www.littelfuse.com/series/PMT8.html">www.littelfuse.com/series/PMT8.html</a>	PMT8	90 VDC

Figure 35 shows a typical outdoor twisted pair network in which Gas Discharge arresters have been incorporated.



**Figure 35.** Network and Shield Lightning Protection

When the network data line extends outside of a building or grounded structure, **every** FT 6000 Smart Transceiver or Neuron 6000 Processor device on the network segment, whether located indoors or outdoors, must be equipped with surge protection circuitry. Additionally, protection devices must be added to the network at every point where the network cable exits the building or structure.

---

## Avoiding Magnetic Field Interference

All transformer-based transceivers are vulnerable to stray magnetic fields that can interfere with the transformer coupling. In most environments, stray magnetic field noise is not a concern for FT 6000 Smart Transceivers or Neuron 6000 Processors with external transceivers. However, high frequency external magnetic fields can couple sufficient energy into the transceiver to cause erratic network performance or, in some cases, cause data traffic to cease.

One possible source of stray magnetic fields is a DC-DC switching power supply, or regulator, using unshielded switching inductors located in close proximity to the transceiver. To minimize magnetic coupling into the transceiver, the switching magnetics of power supplies should be kept at least 7.5 cm (3 inches) from the FT 6000 Smart Transceiver or Neuron 6000 Processor with external transceiver. Otherwise, noise induced into the receiver could affect communications.

If you suspect magnetic field interference, you should measure the level of noise at the FT 6000 Smart Transceiver or Neuron 6000 Processor with external transceiver. You can measure the noise induced by a switching power supply by using an oscilloscope with differential probes having at least 5 V common-mode range with 50 dB of common-mode rejection to measure the voltage between the Series 6000 chip's NETP and NETN pins during an interval when there is no packet activity. You can also identify the source of the magnetic noise by moving the suspected source away from the FT 6000 Smart Transceiver or Neuron 6000 Processor with external transceiver by connecting it to at least 15 cm twisted-pair wires and monitoring the noise at the NETP and NETN pins.

The noise between the NETP and NETN pins should be less than 15 mV peak-to-peak differential. For noise that is magnetically coupled from a switching power supply, the noise will be synchronous with the power supply switching frequency. The worst case occurs when the coupled noise is between 10 kHz and 300 kHz, the center of the network data communication band. If the noise is greater than 15 mV peak-to-peak, you should take steps to reduce the coupling effect. The easiest solution is to provide more distance between the power supply and the FT 6000 Smart Transceiver or Neuron 6000 Processor with external transceiver.

For noisy power converters, shielded inductors can provide a solution to magnetic field interference. In the commonly used buck DC-DC converter, a shielded inductor can be used instead of an open-slug inductor to significantly lower the amount of stray magnetic field generated by the DC-DC converter. For example, Taiyo Yuden's LHFP-series inductor can be used instead of their LHL-series, and TDK's FS-series inductor can be used instead of their EL or ELF-series. In transformer-based DC-DC converters, the power supply designer should take care to choose a transformer style that generates minimum external stray magnetic fields. For example, a pot-core DC-DC transformer will generally produce less stray magnetic field than will an E-E core transformer, and the stray fields that it does generate are vertical when they go through the plane of the PCB. A common way to minimize magnetic fields emitted from power supply transformers is to wrap a "shorted-turn" of copper tape around the transformer in the same direction as the transformer winding.

In addition to power supplies, other noise sources can include DC motor controllers and industrial ovens or heaters. For these noise sources, shielding the emitting device is often the most effective approach to solving magnetic field interference problems.

## Summary and Testing Results

Table 26 summarizes the results of the immunity and RF testing for a typical LONWORKS application based on an FT 6000 Smart Transceiver with the FT-X3 Communications Transformer. EMC testing results for the Neuron 6000 Processor depend on the specific network transceiver used.

**Table 26.** Immunity and EMI Results

Test	FT 6000 Smart Transceiver with FT-X3 Communications Transformer
EN 61000-4-2 ESD	15 kV Air 8 kV Contact (Level 4)
EN 61000-4-3 Radiated RF	10 V/m (Level 3)
EN 61000-4-4 Network Burst	2 kV (Level 4)
EN 61000-4-5 Network Surge	2 kV or 6 kV (depends on clamping diodes used; see <b>Table 21</b> ) (Level 3)
EN 61000-4-6 Conducted RF	10 V <sub>RMS</sub> (Level 3)
CISPR 22 Radiated EMI	Class B
CISPR 22 Conducted EMI	Class B



# 5

## **Network Cabling and Connections for FT Devices**

This chapter describes the network connections and cable types supported for FT devices.

---

## Network Connection

For a TP/FT-10 channel, the network connection (from the NETP and NETN pins) is polarity insensitive. Therefore, either of the two twisted pair wires can be connected to either of these network connections.

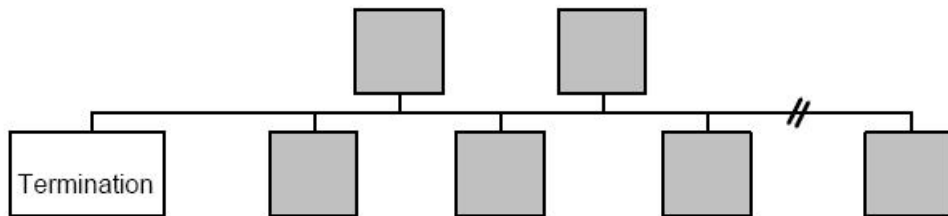
For any of the supported cable types, the average temperature of the wire must not exceed +55 °C, although individual segments of wire can be as hot as +85 °C.

As a general rule, TP/FT-10 network channel communication cables should be separated from high voltage power cables. Follow local electrical codes with regard to cable placement.

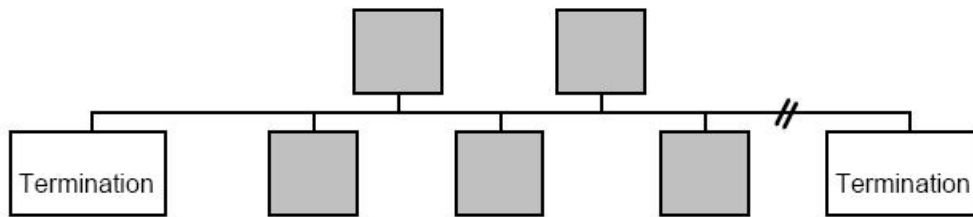
---

## Network Topology Overview

The TP/FT-10 network is designed to support free topology wiring, and can accommodate bus, star, loop, or any combination of these topologies. Series 6000 devices can be located at any point along the network wiring. This capability simplifies system installation, and makes it easy to add devices if the network needs to be expanded. Figure 36 through Figure 40 present five different network topologies. The actual termination circuit varies by application.

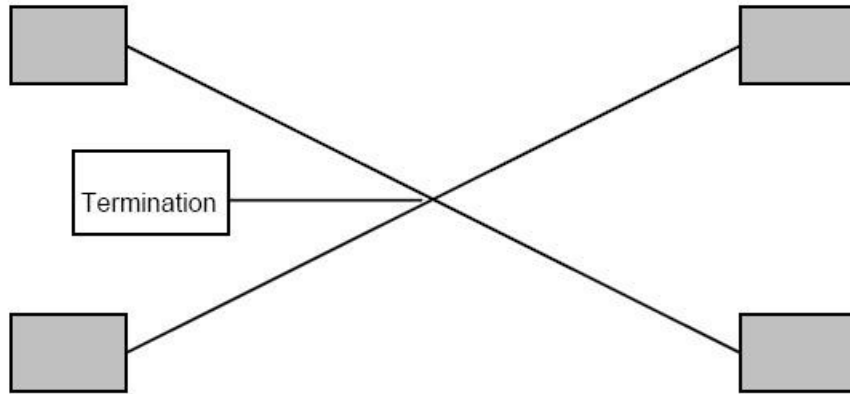


**Figure 36.** Singly Terminated Bus Topology

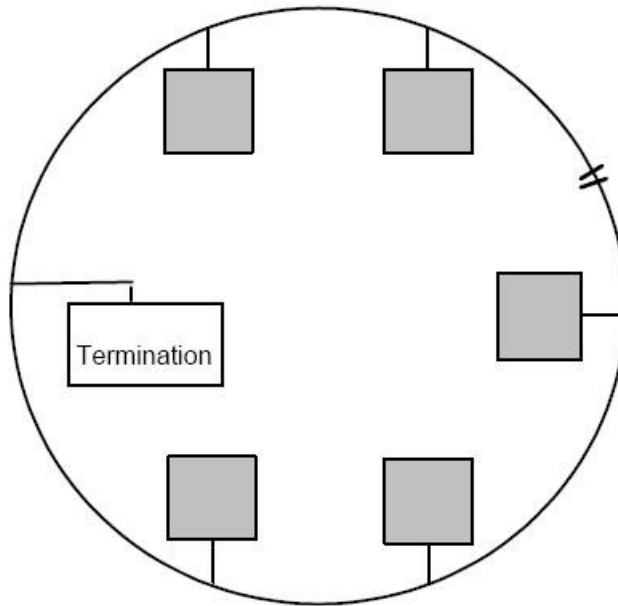


**Figure 37.** Doubly Terminated Bus Topology

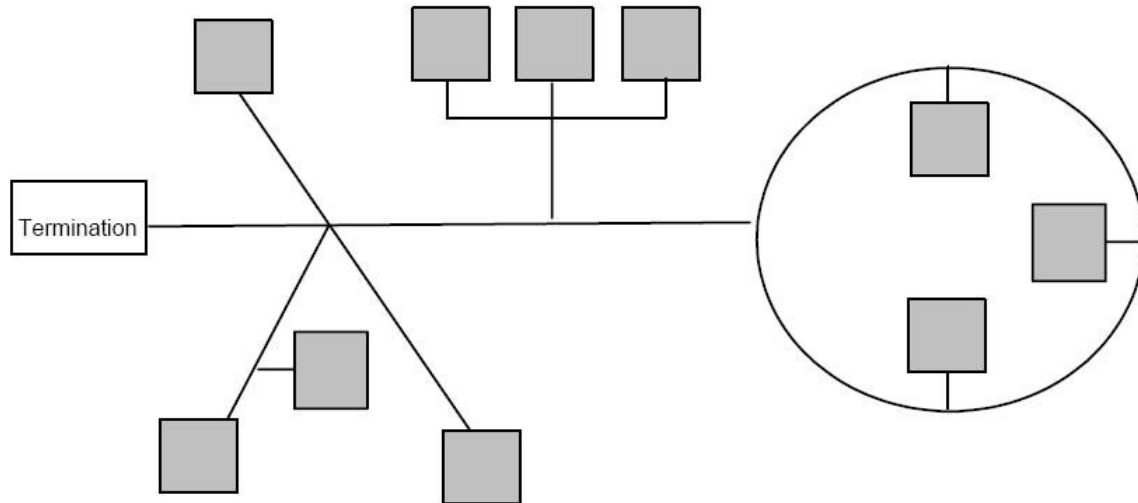




**Figure 38.** Star Topology



**Figure 39.** Loop, or Ring, Topology



**Figure 40.** Mixed Topology

In the event that the limits for the number of transceivers or total wire distance are exceeded, then one FTT physical layer repeater (PLR) can be added to interconnect two segments and double the overall system capability. FTT-10A Transceivers are used to make physical layer repeaters. See the *FTT-10A Free Topology Transceiver User's Guide* for more information about physical layer repeaters.

---

## System Performance and Cable Selection

Echelon has qualified the following types of cable types for use with TP/FT-10 channels:

- A generic American wire gauge (AWG) 16 (1.3 mm diameter) plenum-rated twisted-pair cable (similar to Belden® 85102 2-conductor wire)
- A generic American wire gauge (AWG) 16 (1.3 mm diameter) standard twisted-pair cable (similar to Belden 8471 1-Pair wire)
- National Electrical Manufacturers Association (NEMA) Type 4 cable (this cable is *not* equivalent to TIA Category 4 cable)
- AWG 24 (0.511 mm) ANSI/TIA/EIA-568-B.2-2001 Category 5 or Category 6 twisted-pair wire
- An EN 50441 telecommunications cable, such as J-Y(ST)Y

Based on the cost, performance, and availability of these different cable types, system designers can choose the most appropriate cable for their application.

Appendix B, *Qualified TP/FT-10 Cable Specifications*, lists the electrical specifications for these cables. The *Junction Box and Wiring Guidelines for Twisted Pair LONWORKS Networks* engineering bulletin (005-0023-01) provides a list of cable vendors for each type of supported cable. This bulletin is available from the Echelon Web site ([www.echelon.com](http://www.echelon.com)). These cables have been qualified by Echelon in a generic form, and are available from vendors in a number of variations, including shielded, unshielded, plenum jacketing, and non-plenum jacketing. Additionally, Echelon has qualified two 16 AWG (1.3 mm) Belden cables, and one cable used in specific applications in the European market (type J-Y(ST)Y cable).

TP/FT-10 channels must meet the system specifications and transmission specifications described in the following sections. When you create documentation and installation

procedures for TP/FT-10 channels, be sure to include the TP/FT-10 system specifications and, based upon the cable used, the appropriate transmission distance specifications. Incorporating these specifications can ensure a smoother installation, and provide a resource for the installer who must troubleshoot the installation.

**Note:** The following specifications apply to a single network segment. You can combine multiple segments by using FTT-10A based physical layer repeaters to increase the number of devices and distance as described in the *FTT-10A Free Topology Transceiver User's Guide*.

---

## System Specifications

Each network segment can include up to 64 FT-X3 (or FT X1 or FT-X2) Transformers and FT Smart Transceivers.

You can use LPT-11 transceivers on network segments with FTT-10A transceivers and FT Smart Transceivers, but they are subject to additional constraints, particularly on distance. See the *LONWORKS LPT-11 Link Power Transceiver User's Guide* for more information.

The average temperature of the wire must not exceed +55°C, although individual segments of wire may be as hot as +85°C.

As a general rule, the TP/FT-10 channel communication cables should be separated from high voltage power cables. Follow local electrical codes with regard to cable placement.

---

## Transmission Distance Specifications

Table 27 and Table 28 list the transmission distance specifications for the supported cable types.

**Table 27.** Doubly Terminated Bus Topology Specifications

Cable Type	Maximum Bus Length (Meters)
Belden 85102	2700
Belden 8471	2700
NEMA Type 4, 22 AWG	1400
J-Y(ST)Y 2x2x0.8	900
ANSI/TIA/EIA Category 5 or 6	900

A doubly-terminated bus can have stubs of up to 3 meters from the bus to each device.

**Table 28.** Free Topology Specifications

Cable Type	Maximum Device-to-Device Distance (Meters)	Maximum Total Wire Length (Meters)
Belden 85102	500	500
Belden 8471	400	500
NEMA Type 4, 22 AWG	400	500

Cable Type	Maximum Device-to-Device Distance (Meters)	Maximum Total Wire Length (Meters)
J-Y(ST)Y 2x2x0.8	320	500
ANSI/TIA/EIA Category 5 / 6	250	450

The free topology transmission distance specification includes two components that must both be met for proper system operation. The distance from each transceiver to all other transceivers and to the termination (including the LPI-10 termination, if used) must not exceed the *maximum device-to-device distance*. If multiple paths exist, for example, in a loop topology, then the longest path should be used for calculations. The *maximum total wire length* is the total length of wire within a segment.

---

## Cable Termination and Shield Grounding

TP/FT-10 network segments require termination for proper data transmission performance. The type of terminator varies depending on whether shielded or unshielded cable is used. Free Topology and bus topology networks also differ in their termination requirements. The following sections describe the various terminators and termination procedures.

---

### *Free Topology Network Segment*

For a Free Topology segment, only one termination is required; it can be placed anywhere on the Free Topology segment. There are two choices for the termination:

- RC circuit, with  $R_a = 52.3 \Omega \pm 1\%$ , 1/8 W
- LPI-10 Link Power Interface, with jumper at the “1 CPLR” setting

Figure 41 shows the RC circuit for twisted-pair termination.

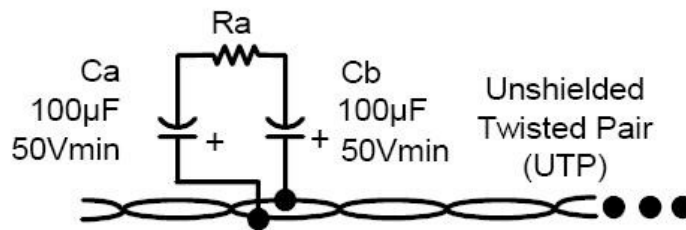
---

### *Doubly Terminated Bus Topology Segment*

For a doubly terminated bus topology, two terminations are required: one at each end of the bus. There are two choices for each termination:

- RC circuit, with  $R_a = 105 \Omega \pm 1\%$ , 1/8 W
- LPI-10 Link Power Interface, with jumper at the “2 CPLR” setting

Only one LPI-10 interface is supported per segment. The LPI-10 contains the two required terminators. The other terminator must be an RC-type.



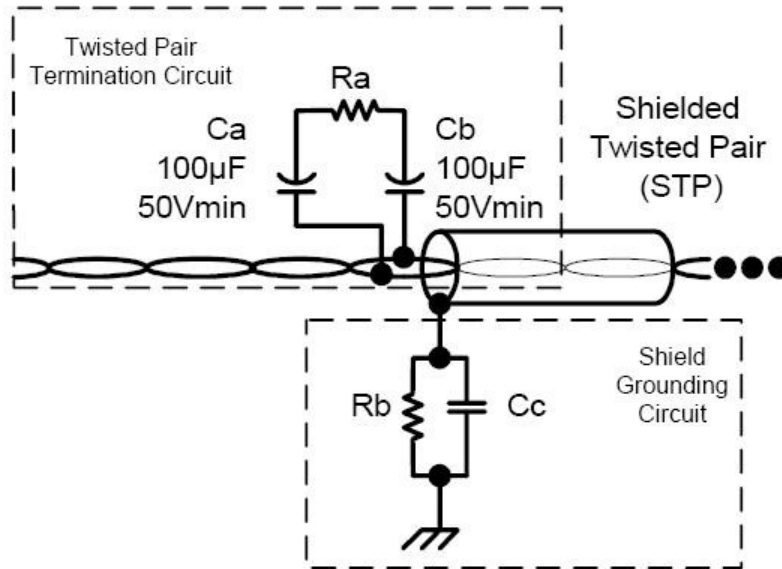
**Figure 41.** Twisted-Pair Termination

Ca and Cb are typically aluminum-electrolytic type for improved longevity in the presence of ESD. Be sure to observe their polarity.

---

## Grounding Shielded Twisted Pair Cable

When using shielded twisted-pair cable, terminate the twisted pair *and* ground the cable shield, as shown in Figure 42.



**Figure 42.** Shielded Twisted-Pair Termination and Grounding

Use the termination described in *Free Topology Network Segment* or in *Doubly Terminated Bus Topology Segment*. The cable shield should be grounded using a capacitor to tie the shield to earth ground, and a large-value resistor to bleed off any static charge on the shield.

Tie the shield to earth ground through a capacitor, instead of using a direct connection, to avoid DC and 50/60 Hz ground paths from being formed through the shield. Typical values for  $R_b$  and  $C_c$  are:

- $C_c = 0.1\ \mu\text{F}$ , 10%, Metalized Polyester,  $\geq 100\text{V}$
- $R_b = 470\ \text{k}\Omega$ , 1/4 W,  $\pm 5\%$

The cable shield should be grounded at least once per segment, and preferably at each device. Grounding the shield at every device assists in suppressing 50/60 Hz standing waves.



# 6

## Input/Output Interfaces for the Series 6000

This chapter provides an overview of the I/O models that are available for Series 6000 devices.

See the *I/O Model Reference for Smart Transceivers and Neuron Chips* for more information about the available I/O models.

---

## Overview

Echelon's Neuron Chips and Smart Transceivers connect to application-specific external hardware through 11 or 12 I/O pins, named IO0-IO11. You can configure these pins to provide flexible input and output (I/O) functions with minimal external circuitry. These functions are described as *I/O models*.

The Neuron C programming language allows the application programmer to declare *I/O objects* that use one or more I/O pins. An I/O object is a software instance of an I/O model, and provides programmable access to an I/O driver for a specified on-chip I/O hardware configuration and a specified input or output waveform definition. Programs can then refer to most of these objects through **io\_in()** and **io\_out()** system calls to perform the actual input or output function during execution of the program. Because events are associated with changes in input values, the task scheduler can execute associated application code when these changes occur.

There are many different I/O models available for use with the Neuron Chips and Smart Transceivers. Most I/O models are available in system images by default. If an I/O model is required by an application, but is not included in the default system image, the development tool links the appropriate models into available memory space. For Series 6000 device designs, the model is added to the application image.

Series 6000 chips also support application-specific interrupts, which can trigger on either or both edges, or on either level, for any of the I/O pins, regardless of any associated I/O object. See the *Neuron C Programmer's Guide* for more information about interrupts.

See the *I/O Model Reference for Smart Transceivers and Neuron Chips* for more information about the available I/O models and how to use them.

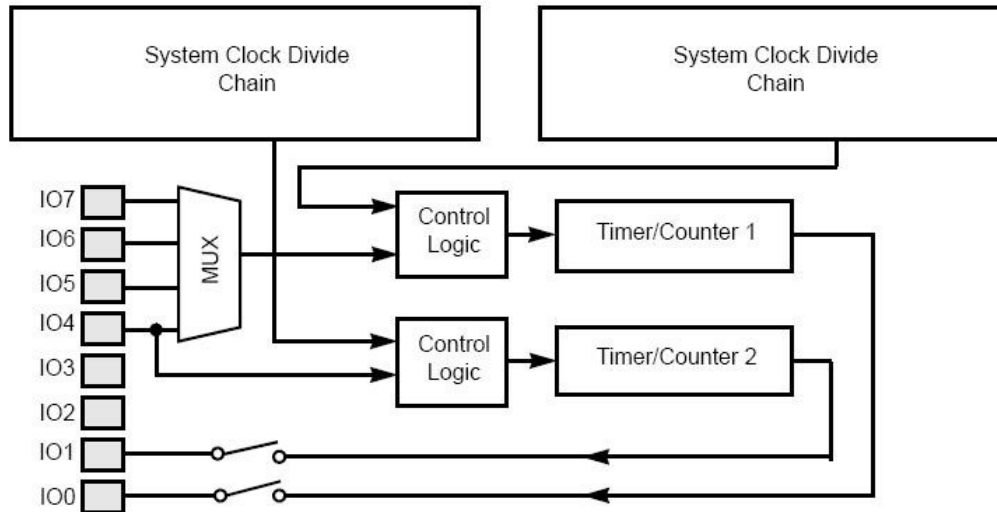
---

## Two 16-Bit Timer/Counters

Two classes of I/O model use internal timer/counters. The timer/counters are implemented as a register that is writable by the application processor, a 16-bit counter, and a latch that is readable by the processor. The 16-bit registers are accessed 1 byte at a time. Series 6000 chips have two timer/counters, as shown in Figure 43:

- Timer/Counter 1, with input that is selectable among pins IO4 – IO7 and output to pin IO0
- Timer/Counter 2, with input from pin IO4 and output to pin IO1





**Figure 43.** Timer/Counter Circuits

No I/O pins are dedicated to timer/counter functions. If, for example, Timer/Counter 1 is used for input signals only, then IO0 is available for other input or output functions. Clock and enable inputs for the timer/counters can be from external pins, or from scaled clocks derived from the system clock. The clock rates of the two timer/counters are independent of each other. External clock actions occur optionally on the rising edge, the falling edge, or both edges of the input.

Series 6000 chips also support up to one application-specific interrupt task per Timer/Counter unit. These interrupts are triggered by a condition selected through the choice of I/O object that uses the Timer/Counter unit; see the *Neuron C Programmer's Guide* for more information about timer/counter interrupts.

See the *I/O Model Reference for Smart Transceivers and Neuron Chips* for more information about how to use the timer/counters.

---

## Summary of the Available I/O Objects

Many I/O models are available for Neuron Chips and Smart Transceivers. Certain I/O models are available only for specific chip types, but most are available to all Neuron Chips and Smart Transceivers. For detailed information please see the *I/O Model Reference for Neuron Chips and Smart Transceivers*. The I/O models are grouped into the following categories:

- *Direct I/O Models* are based on a logic level at the I/O pins; none of the Neuron Chip or Smart Transceiver hardware's timer/counters are used in conjunction with these I/O models. These models can be used in multiple, overlapping combinations within the same Neuron Chip or Smart Transceiver. Direct I/O models include the following types:

### *Input Model Types*

**bit**  
**byte**  
**leveldetector**  
**nibble**  
**touch**

### *Output Model Types*

**bit**  
**byte**  
**nibble**  
**touch**

- *Timer/Counter I/O Models* use a timer/counter circuit in the Neuron Chip or Smart Transceiver. Each Neuron Chip and each Smart Transceiver has two timer/counter circuits: One whose input can be multiplexed, and one with a dedicated input. Timer/counter I/O models include the following types:

*Input Model Types*

**dualslope**  
**edgelog**  
**infrared**  
**ontime**  
**period**  
**pulsecount**  
**quadrature**  
**totalcount**

*Output Model Types*

**edgedivide**  
**frequency**  
**infrared\_pattern**  
**oneshot**  
**pulsecount**  
**pulsewidth**  
**stretchedtriac**  
**triac**  
**triggeredcount**

- *Serial I/O Models* are used for transferring data serially over a pin or a set of pins. The **neurowire**, **i2c**, **magcard**, **magcard\_bitstream**, **magtrack1**, and **serial** I/O models are mutually exclusive within a single Neuron Chip or Smart Transceiver. Both the input and output versions of a serial I/O model can coexist within a single Neuron Chip or Smart Transceiver. Serial I/O models include the following types:

*Serial Input Model Types*

**bitshift**  
**magcard**  
**magcard\_bitstream**  
**magtrack1**  
**serial**  
**wiegand**

*Serial Output Model Types*

**bitshift**  
**serial**

*Serial Input/Output Model Types*

**i2c**  
**neurowire**  
**sci**  
**spi**

- *Parallel I/O Models* are used for high-speed bidirectional I/O. I/O models within this group use all of the Neuron Chip or Smart Transceiver I/O pins. The parallel I/O models include the following types:

*Parallel Input/Output Model Types*

**muxbus**  
**parallel**

Table 29 through Table 33 list the available I/O models within each category. **Figure 46** summarizes the pin configuration for each of the I/O models. A single device can use various I/O models of different types simultaneously.

**Table 29.** Summary of the Direct I/O Models

I/O Model	Applicable I/O Pins	Total Pins per Object	Input/Output Value
Bit Input <sup>1</sup>	IO0 – IO11	1	0, 1 binary data

<b>I/O Model</b>	<b>Applicable I/O Pins</b>	<b>Total Pins per Object</b>	<b>Input/Output Value</b>
Bit Output <sup>1</sup>	IO0 – IO11	1	0, 1 binary data
Byte Input	IO0 – IO7	8	0 – 255 binary data
Byte Output	IO0 – IO7	8	0 – 255 binary data
Leveldetect Input	IO0 – IO7	1	Logic 0 level detected
Nibble Input	Any adjacent four in IO0 – IO7	4	0 – 15 binary data
Nibble Output	Any adjacent four in IO0 – IO7	4	0 – 15 binary data
Touch I/O	IO0 – IO7	1	Up to 2048 bits of input or output bits
<b>Notes:</b> <ol style="list-style-type: none"> <li>The IO11 pin for this I/O model is available for the following device types: PL 3120-E4, PL 3150, PL 3170, FT 5000, Neuron 5000, FT 6000, and Neuron 6000.</li> </ol>			

**Table 30.** Summary of the Parallel I/O Models

<b>I/O Model</b>	<b>Applicable I/O Pins</b>	<b>Total Pins per Object</b>	<b>Input/Output Value</b>
Muxbus I/O	IO0 – IO10	11	Parallel bidirectional port using multiplexed addressing
Parallel I/O <sup>1</sup>	IO0 – IO11	12	Parallel bidirectional handshaking port
<b>Notes:</b> <ol style="list-style-type: none"> <li>The IO11 pin for this I/O model is available for the following device types: FT 5000, Neuron 5000, FT 6000, and Neuron 6000.</li> </ol>			

**Table 31.** Summary of the Serial I/O Models

I/O Model	Applicable I/O Pins	Total Pins per Object	Input/Output Value
Bitshift Input	Any adjacent pair (except IO7 + IO8 & IO10 + IO11)	2	Up to 16 bits of clocked data
Bitshift Output	Any adjacent pair (except IO7 + IO8 & IO10 + IO11)	2	Up to 16 bits of clocked data
I <sup>2</sup> C	IO8 + IO9 or IO0 + IO1	2	Up to 255 bytes of bidirectional serial data
Magcard Bitstream	IO8 + IO9 + (one of IO0 – IO7)	2 or 3	Unprocessed serial data stream from a magnetic card reader
Magcard Input	IO8 + IO9 + (one of IO0 – IO7)	2 or 3	Encoded ISO7811 track 2 data stream from a magnetic card reader
Magtrack1	IO8 + IO9 + (one of IO0 – IO7)	2 or 3	Encoded ISO3554 track 1 data stream from a magnetic card reader
Neurowire I/O	IO8 + IO9 + IO10 + (one of IO0 – IO7)	4	Up to 256 bits of bidirectional serial data
SCI (UART) <sup>1</sup>	IO8 + IO10	2	Up to 255 bytes input and 255 bytes output
Serial Input	IO8	1	8-bit characters
Serial Output	IO10	1	8-bit characters
SPI	IO8 + IO9 + IO10 + (IO7)	3 or 4	Up to 255 bytes of bidirectional data
Wiegand Input	Any adjacent pair in IO0 – IO7	2	Encoded data stream from Wiegand card reader
<b>Notes:</b>			
1. The SCI (UART) model is available for the following device types: PL 3120-E4, PL 3150, PL 3170, FT 5000, Neuron 5000, FT 6000, and Neuron 6000.			

**Table 32.** Summary of the Timer/Counter Input Models

I/O Model	Applicable I/O Pins	Total Pins per Object	Input/Output Value
Dualslope Input	IO0, IO1 + (one of IO4 – IO7)	2	Comparator output of the dualslope converter logic
Edgelog Input	IO4	1	A stream of input transitions
Infrared Input	IO4 – IO7	1	Encoded data stream from an infrared demodulator
Overtime Input	IO4 – IO7	1	Pulse width of 0.2 $\mu$ s – 1.678 s
Period Input	IO4 – IO7	1	Signal period of 0.2 $\mu$ s – 1.678 s
Pulsecount Input	IO4 – IO7	1	0 – 65,535 input edges during 0.839 s
Quadrature Input	IO4 + IO5, IO6 + IO7	2	$\pm$ 16,383 binary Gray code transitions
Totalcount Input	IO4 – IO7	1	0 – 65,535 input edges

**Table 33.** Summary of the Timer/Counter Output Models

I/O Model	Applicable I/O Pins	Total Pins per Object	Input/Output Value
Edgedivide Output	IO0, IO1 + (one of IO4 – IO7)	2	Output frequency is the input frequency divided by a user-specified number
Frequency Output	IO0, IO1	1	Square wave of 0.3 Hz to 2.5 MHz
Infrared Pattern Output	IO0, IO1	1	Series of timed repeating square wave output signals
Oneshot Output	IO0, IO1	1	Pulse of duration 0.2 $\mu$ s to 1.678 s
Pulsecount Output	IO0, IO1	1	0 – 65,535 pulses
Pulsewidth Output	IO0, IO1	1	0 – 100% duty cycle pulse train
Stretched Triac Output <sup>1</sup>	IO0, IO1 + (one of IO4 – IO7)	2	Delay of output pulse with respect to input edge

I/O Model	Applicable I/O Pins	Total Pins per Object	Input/Output Value
Triac Output <sup>2</sup>	IO0, IO1 + (one of IO4 – IO7)	2	Delay of output pulse with respect to input edge
Triggered-Count Output	IO0, IO1 + (one of IO4 – IO7)	2	Output pulse controlled by counting input edges
<b>Notes:</b> <ol style="list-style-type: none"> <li>1. The Stretched Triac Output model is available for the following device types: FT 5000, Neuron 5000, FT 6000, and Neuron 6000.</li> <li>2. Dual-edge triggering is not available for the following device types: Neuron 3150, FT 3150, or PL 3150.</li> </ol>			

Neuron Chips and Smart Transceivers have two 16-bit timer/counters on-chip. The input to timer/counter 1, also called the *multiplexed timer/counter*, is selectable among pins IO4 – IO7, through a programmable multiplexer and its output can be connected to pin IO0. The input to timer/counter 2, also called the *dedicated timer/counter*, can be connected to pin IO4 and its output to pin IO1.

The timer/counters are implemented as a 16-bit load register writable by the CPU, a 16-bit counter, and a 16-bit latch readable by the CPU. The load register and latch are accessed a byte at a time. No I/O pins are dedicated to timer/counter functions. If, for example, timer/counter 1 is used for input signals only, then IO0 is available for other input or output functions. Timer/counter clock and enable inputs can be from external pins, or from scaled clocks derived from the system clock; the clock rates of the two timer/counters are independent of each other. External clock actions occur optionally on the rising edge, the falling edge, or both rising and falling edges of the input.

For Series 6000 devices, many of the timer/counter I/O models can also trigger interrupt tasks, which can provide minimum application latency for I/O events that are related to the timer/counter models. See the *Neuron C Programmer's Guide* for more information about defining and using interrupts for Series 6000 devices.

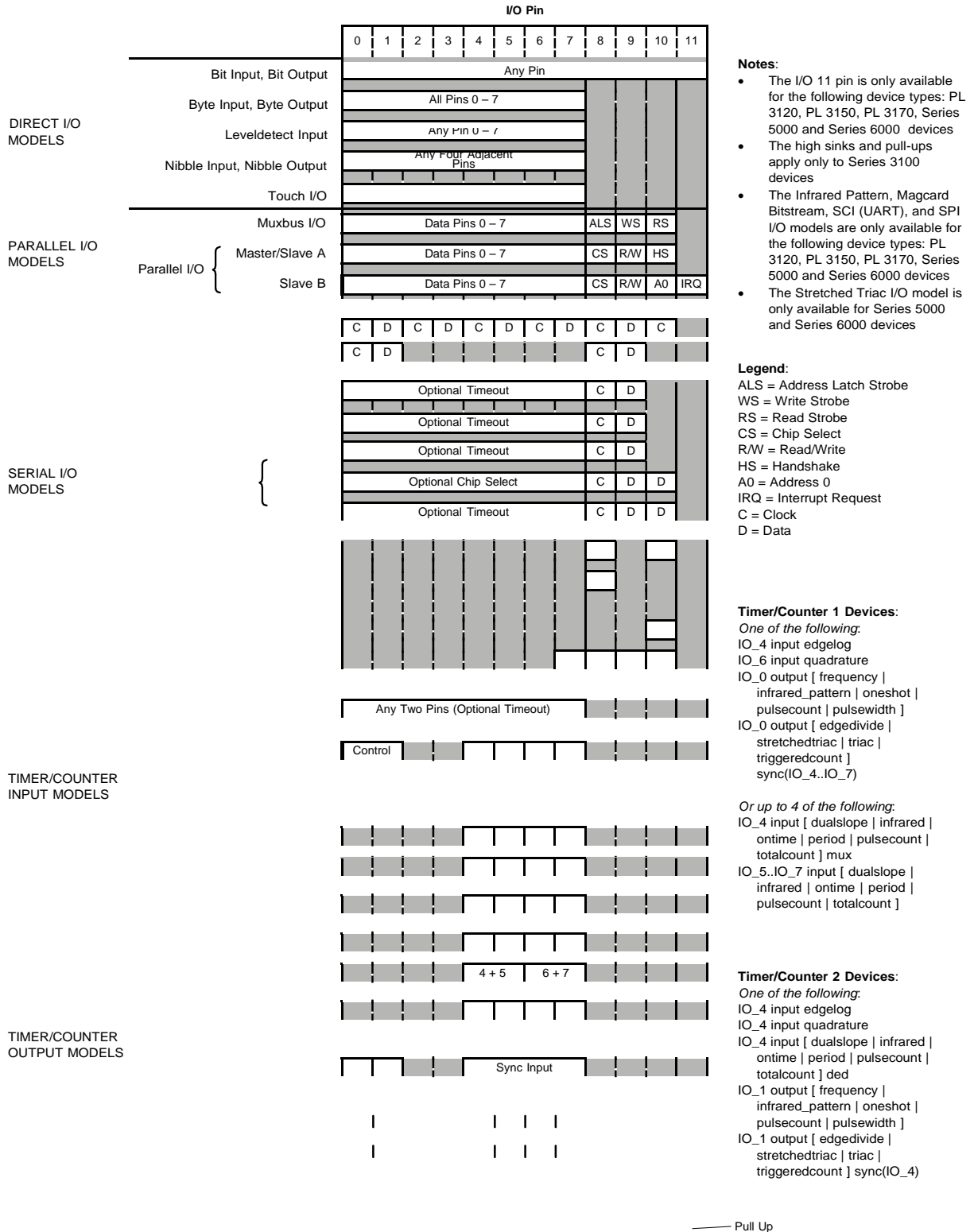
Multiple timer/counter input objects can be declared on different pins within a single application. By calling the `io_select()` function, the application can use the first timer/counter to implement up to four different input objects. If a timer/counter is configured to implement one of the output models, or is configured as a quadrature input object, then it cannot be reassigned to another timer/counter object in the same application program.

The following guidelines for declaring I/O object types apply to the I/O models shown in Figure 44:

- Up to 16 I/O objects can be declared.
- Timer/counter 1 can be multiplexed for up to four input objects.
- The **neurowire**, **i2c**, **magcard**, **magcard\_bitstream**, **magtrack1**, and **serial** I/O models are mutually exclusive. One or more of a single type of these I/O models can be declared in one program.
- Because the **parallel** and **muxbus** I/O models require all I/O pins for some Neuron Chips and Smart Transceivers, no other object types can be declared when either of these objects is declared. You can declare the IO11 pin as a **bit** input or output in

addition to the **parallel** or **muxbus** object for the following device types: PL 3120-E4, PL 3150, or PL 3170. For Series 6000 devices, you can also declare the IO11 pin as a **bit** input or output in addition to the **parallel** (master or slave A mode) or **muxbus** object; the IO11 pin serves as an IRQ pin for the **parallel** (slave B mode) object.

- Direct I/O object types (such as **bit**, **nibble**, **byte**) can be declared in any combination. Timer/counter, **serial**, and **neurowire** I/O object declarations override the pin directions of any overlaying direct I/O object types.
- The **quadrature** and **dualslope** input objects cannot be multiplexed with other input objects on timer/counter 1. The **edgelog** input uses both timer/counters and is exclusive of any other timer/counter objects.
- The **bitshift** I/O objects cannot be declared on the same I/O pins as timer/counter objects. Direct I/O objects can be overlaid with **bitshift** I/O objects. Two adjacent **bitshift** I/O objects cannot share any I/O pins.



- Notes:**
- The I/O 11 pin is only available for the following device types: PL 3120, PL 3150, PL 3170, Series 5000 and Series 6000 devices
  - The high sinks and pull-ups apply only to Series 3100 devices
  - The Infrared Pattern, Magcard Bitstream, SCI (UART), and SPI I/O models are only available for the following device types: PL 3120, PL 3150, PL 3170, Series 5000 and Series 6000 devices
  - The Stretched Triac I/O model is only available for Series 5000 and Series 6000 devices

**Legend:**  
ALS = Address Latch Strobe  
WS = Write Strobe  
RS = Read Strobe  
CS = Chip Select  
R/W = Read/Write  
HS = Handshake  
A0 = Address 0  
IRQ = Interrupt Request  
C = Clock  
D = Data

**Timer/Counter 1 Devices:**  
One of the following:  
IO\_4 input edgelog  
IO\_6 input quadrature  
IO\_0 output [ frequency | infrared\_pattern | oneshot | pulsecount | pulsewidth ]  
IO\_0 output [ edgedivide | stretchedtriac | triac | triggeredcount ]  
sync(IO\_4..IO\_7)

Or up to 4 of the following:  
IO\_4 input [ dualslope | infrared | ontime | period | pulsecount | totalcount ] mux  
IO\_5..IO\_7 input [ dualslope | infrared | ontime | period | pulsecount | totalcount ]

**Timer/Counter 2 Devices:**  
One of the following:  
IO\_4 input edgelog  
IO\_4 input quadrature  
IO\_4 input [ dualslope | infrared | ontime | period | pulsecount | totalcount ] ded  
IO\_1 output [ frequency | infrared\_pattern | oneshot | pulsecount | pulsewidth ]  
IO\_1 output [ edgedivide | stretchedtriac | triac | triggeredcount ] sync(IO\_4)

**Figure 44.** Pin Configuration Summary for the I/O Models



**Example:** The following I/O object types can be combined for a Neuron Chip or Smart Transceiver:

- 1 **parallel** I/O object type (on **IO\_0..IO10**)

OR

- 1 **muxbus** I/O object type (on **IO\_0..IO10**)

OR

- A combination of any or all of the other I/O models *A* through *E* shown in Table 34:

**Table 34.** Example I/O Model Combinations

A	B	C	D	E
1 to 4 timer/counter inputs (multiplexed on <b>IO_4, IO_5, IO_6, IO_7</b> ), including <b>quadrature</b> input on <b>IO_6</b>	1 timer/counter input (on <b>IO_4</b> ), including <b>quadrature</b> input on <b>IO_4</b>	1 <b>neurowire</b> I/O object (on <b>IO_8, IO_9, IO_10</b> ) and 1 of <b>IO_0 ... IO_7</b>	Any direct I/O object type on any pin ( <b>IO_0</b> through <b>IO_10</b> )	A bit I/O object on <b>IO_11</b>
OR	OR	OR		
1 timer/counter output (on <b>IO_0</b> )	1 timer/counter output (on <b>IO_1</b> )	1 serial I/O object type (on <b>IO_8, IO_10</b> )		

## Hardware Considerations

For a description of the electrical characteristics of the I/O pins, see *Characteristics of the Digital Pins* or the appropriate Series 3100, Series 5000, or Series 6000 device data sheet. Pins that are configured as outputs can also be read as inputs, returning the value that was last written to the pin. In addition, an application program can optionally specify the initial values of digital outputs.

For Series 3100 devices, pins IO4 – IO7 and IO11 have optional pull-up current sources that act as pull-up resistors. You use a Neuron C compiler directive (**#pragma enable\_io\_pullups**) to enable these pull-ups. Also for Series 3100 devices, pins IO0 – IO3 have high current-sink capability (20 mA); the other pins have standard current-sink capability.

For Series 3100 FT Smart Transceivers, the I/O pull-ups are enabled during the stack initialization and built-in self-test (BIST) task (see the *FT 3120 / FT 3150 Smart Transceiver Data Book* for more information about the stack initialization and BIST task).

For Series 6000 devices, the I/O pins do not have configurable pull-ups or high current-sink capability. If your I/O circuitry requires pull-up resistors, you must add them to the hardware design for the device. The I/O pins on a Series 6000 device have an 8 mA current

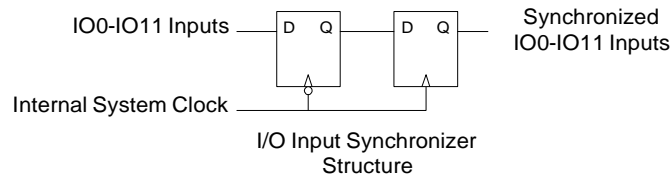
source and sink capability. If your I/O circuitry has higher current requirements, you can add external driver circuitry (for example, using a Fairchild Semiconductor® 74AC245/74ACT245 Octal Bidirectional Transceiver or 74VHC245/74VHCT245 Octal Buffer/Line Driver).

In addition, the Series 6000 device pins are all 3.3 V pins: the input pins are 5 V tolerant, and the output pins are CMOS compatible. Series 3100 device pins are *all* 5 V pins.

For Series 3100, Series 5000, and Series 6000 devices, pins IO0 – IO7 have low-level detect latches.

Because the I/O pins are controlled by system firmware, the timing for reading or writing an I/O pin includes latency that can vary by I/O model and even vary by I/O pin. All inputs are software sampled during processing for the Neuron C **when** statement. In general, the latency scales inversely with the system clock rate.

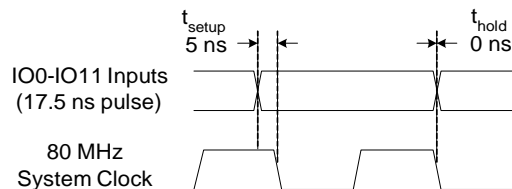
To maintain and provide consistent behavior for external events, and to prevent setup and hold metastability, all I/O pins, when configured as simple inputs, are passed through a hardware synchronization block, shown in Figure 45, that is sampled by the internal system clock.



**Figure 45.** Synchronization Block

I/O pins used for other functions do not have this synchronization requirement.

For Series 6000 devices, the sample rate is equivalent to the system clock rate. For a signal to be reliably synchronized with an 80 MHz system clock, it must be at least 17.5 ns in duration; see Figure 46.



**Figure 46.** Synchronization of External Signals for Series 6000 Devices

Any event that lasts longer than 220 ns (for a Series 3100 device at 10 MHz) or 17.5 ns (for a Series 6000 device at 80 MHz) is synchronized by hardware, but there can be latency in software sampling, which can result in a delay in detecting the event. If the state changes at a faster rate than software sampling can process, the interim changes are not detected.

The following exceptions apply to the use of the synchronization block:

- The chip select (CS~) input used in the slave B mode of the parallel I/O object recognizes rising edges asynchronously.
- The **leveldetect** input is latched by a flip-flop with a 200 ns clock (for Series 3100 devices) or a 12.5 ns clock (for Series 6000 devices). The level detect transition event is latched, but there is a delay in software detection.
- The SCI (UART) and SPI objects are buffered on byte boundaries by the hardware, and are transferred to memory using an interrupt.

- Events on the I/O pins for the input timer/counter functions are accurately measured, and a value returned to a register, regardless of the state of the application or interrupt processor within the Neuron Chip or Smart Transceiver. However, the application processor can be delayed in reading the register.



# 7

## Programming Considerations

This chapter describes software tools for creating applications that run on Series 6000 devices.

---

## Application Program Development

You can perform initial development and test for Neuron C applications using the IzoT NodeBuilder Development Tool. You can also perform application debugging using the IzoT NodeBuilder Development Tool. See the *IzoT NodeBuilder User's Guide* for detailed instructions on developing, testing, and debugging applications.

For initial device development, you should use the FT 6000 EVB Evaluation Boards that are included with the FT 6000 EVK. These boards include sample applications that demonstrate simple Neuron C applications for an FT 6000 Smart Transceiver. See the *FT 6000 EVB Hardware Guide* for more information about the FT 6000 EVB Evaluation Boards.

---

## IzoT NodeBuilder Development Tool

The IzoT NodeBuilder Development Tool is a hardware and software platform that is used to develop applications for Neuron Chips and Echelon Smart Transceivers. The IzoT NodeBuilder tool enables you to do the following tasks:

- View standard resource file definitions for SNVTs, SCPTs, and standard functional profiles.
- Create your own resource files with your UNVTs, UCPTs, and user functional profiles.
- Automatically generate Neuron C code that implements your device interface.
- Edit your Neuron C code to implement your device functionality.
- Compile and build your application, and download it to an FT 6000 EVB Evaluation Board or to your own devices.
- Test with prototype I/O hardware on the FT 6000 EVB Evaluation Board, use the FT 6000 EVB to prototype and test your own I/O hardware, or use your own custom device.
- Install your device into a LONWORKS network and test your device interoperating with other LONWORKS devices.
- Use the LNS Plug-in Framework to develop an LNS plug-in for your device.
- Test your LNS plug-in with the IzoT Commissioning Tool to ensure that your device is easy to configure and install.

The IzoT NodeBuilder Development Tool is required to build applications for Series 6000 devices.

For more information about using the IzoT NodeBuilder Development Tool, see the *IzoT NodeBuilder User's Guide*.

---

## Development Hardware Setup

You configure the IzoT NodeBuilder Development Tool to use the TP/FT-10 channel by using an IzoT compatible network interface with a TP/FT-10 connection; this is typically done using an IzoT Router. For initial device development, use the FT 6000 Evaluation Board device template to target the FT 6000 EVB Evaluation Board for the development environment or as the base template for your Series 6000 device. By default, the hardware template for the FT 6000 EVB platform uses an 80 MHz system clock. You can choose any of

the available system clock rates for your device. However, the recommended internal clock speed is 80MHz. The reason is that transient code must be brought in from flash on demand and the time it takes to load such code is directly proportional to the internal clock speed. See the *IzoT NodeBuilder User's Guide* for more information.

The IzoT NodeBuilder Device Template wizard runs during the creation of a new device template. This wizard provides an opportunity to select predefined hardware templates. At a later point in the development process, you can access the hardware template through the Development and Release folders of the project pane.

During initial device development, use the FT 6000 Evaluation Board hardware template. If this template was not selected in the IzoT NodeBuilder Device Template Wizard, you can access it by dragging the FT 6000 Evaluation Board icon from the Standard Templates folder located in the Hardware Templates folder to the device template Development folder for the device.

---

## Release Hardware Setup

After you have developed, tested, and debugged the application on the FT 6000 EVB Evaluation Board, you must create a hardware template to match the final target hardware.

The IzoT NodeBuilder Development Tool does not include predefined hardware templates for general Series 6000 devices; you can use the FT 6000 Evaluation Board device template as a basis for any custom Neuron 6000 Processor or FT 6000 Smart Transceiver device.

During the initial process of creating a device in the IzoT NodeBuilder Development Tool, select this template in the NodeBuilder Device Template wizard. To access the template later, drag the FT 6000 Evaluation Board icon from Standard Templates folder into the Release folder for the device.

After you place the standard template icon in the User Templates folder, the NodeBuilder Hardware Template Properties window opens with the values of the selected standard template. Change the template's name and modify the template properties as follows:

- From the Hardware tab:
  - Specify the type of Series 6000 device (FT 6000 Smart Transceiver) from the **Neuron chip model** dropdown list box.
  - Specify the clock multiplier value from the **Clock multiplier** dropdown list box. This multiplier value specifies the system clock rate for the device.
- From the Memory tab:
  - Specify the correct external flash memory type using the Non-volatile memory Type dropdown list box.

After you create the hardware template, drag the new hardware template to the device. Drag the newly created icon in the User Templates folder to the Release folder of the device template to complete the procedure.

You can update the user-defined hardware template at any time by double-clicking the template icon. Your new changes affect any projects opened and compiled using this template. A **Build All** might be required if you change a hardware template without making any other changes.

---

# SNMP Support

The Series 6000 chip supports SNMP V1. The following are the commands and objects that are implemented.

---

## *Supported Commands*

SNMP Get  
SNMP Get Next

---

## *Supported Objects*

**Name: system.sysDescr**

ID: 1.3.6.1.2.1.1.1

A textual description of the entity. This value should include the full name and version identification of the system's hardware type, software operating-system, and networking software. The Neuron's implementation returns the string "Neuron".

**Name: system.sysObjectID**

ID: 1.3.6.1.2.1.1.2

The vendor's authoritative identification of the network management subsystem contained in the entity. The Neuron's implementation returns 1.3.6.1.4.1.4941.1.1.

**Name: system.sysUpTime**

ID: 1.3.6.1.2.1.1.3

The time (in hundredths of a second) since the network management portion of the system was last re-initialized.

**Name: system.sysContact**

ID: 1.3.6.1.2.1.1.4

The textual identification of the contact person for this managed node, together with information on how to contact this person. If no contact information is known, the value is the zero-length string. The Neuron's implementation returns the string "Echelon".

**Name: interfaces.ifNumber**

ID: 1.3.6.1.2.1.2.1

The number of network interfaces (regardless of their current state) present on this system. The Neuron's implementation returns 1.

**Name: interfaces.ifInOctets**

ID: 1.3.6.1.2.1.2.2.1.10

The total number of octets received on the interface, including framing characters.

**Name: interfaces.ifInUcastPkts**

ID: 1.3.6.1.2.1.2.2.1.11

The number of packets, delivered by this sub-layer to a higher (sub-)layer, which were not addressed to a multicast or broadcast address at this sub-layer.



**Name: interfaces.ifOutOctets**

ID: 1.3.6.1.2.1.2.2.1.16

The total number of octets transmitted out of the interface, including framing characters.

**Name: interfaces.ifOutUcastPkts**

ID: 1.3.6.1.2.1.2.2.1.17

The total number of packets that higher-level protocols requested be transmitted, and which were not addressed to a multicast or broadcast address at this sub-layer, including those that were discarded or not sent.

---

## Migrating from earlier Neuron Chips

When porting your application to a Series 6000 chip, you can avoid a number of problems by defining all your functions to be resident by specifying the following prior to any code:

```
#pragma resident enabled
```

As long as this doesn't produce space issues, this can be an easy way to go. Assuming this works, then the following additional issues may arise:

1. If your NVM data (i.e., data declared as "eeprom" or read/write CPs) cannot fit in the maximum space allowed (around 7KB), then you must reduce it or opt to store some of this data in data logs.
2. If you use `update_alias()`, `update_nv()`, `access_alias()`, `update_alias()`, you will have to change your application because of the changes made for the extended address table. See "Migrating Self-installation Routines" below.
3. If the program references `read_only_data.neuron_id`, this yields the device MAC ID except that the first byte will be 7 instead of the value in the actual MAC ID used by the device.

If you cannot use "pragma resident enabled", then you may run into these issues as well:

1. If you have a significant amount transient code, then you will want to run the device at 80MHz. If you attempt to run slower, then you may notice that your device performance is not acceptable.
2. If your application implements system callbacks (ISI or `get_nv_length_override()`), then these must be declared as resident by defining them with `"_RESIDENT"`. Furthermore, any functions these callbacks invoke must also be defined as resident.
3. If your program uses interrupts and the interrupt code invokes other functions, these functions must be declared resident by defining them with `"_RESIDENT"`.
4. You cannot debug functions that are not resident.

---

## *Migrating Self-Installation Routines*

Series 6000 chips support more than 15 address table entries (ATEs). This affects the configuration structures referenced by the following APIs:

```
access_nv()  
access_alias()  
update_nv()  
update_alias()
```

Both the NV and Alias configuration structures can be referenced using macros named `NV_STRUCT_TYPE` and `ALIAS_STRUCT_TYPE` – these will work regardless of whether the target device supports the extended address table.

For the `NV_STRUCT_TYPE` data type the “`nv_addr_index_high`” represents the upper 4-bits of an 8-bit address table entry index. The “`nv_addr_index`” field represents the lower 4 bits. When using `update_nv()`, “`nv_addr_index_high`” must be set to represent the upper 4 bits of the address table entry. For entries indexed from 0 to 15, the value would be 0. In the case where the NV is unbound, “`nv_addr_index`” and “`nv_addr_index_high`” must both be set to 15. Correspondingly, `access_nv()` returns a structure with “`nv_addr_index_high`” included.

For the NV Alias configuration structure the same rules apply for the use of the field “`alias_nv.nv_addr_index_high`”.

The actual address table entry count must be referenced using a macro named `ADDRESS_COUNT` and not directly via “`read_only_data.address_count`”.

As an example, to bind network variable index 34 for address table index 6:

```
NV_STRUCT_TYPE nv_copy;  
nv_copy = *access_nv(34);  
nv_copy.nv_addr_index = 6;  
nv_copy.nv_addr_index_high = 0;  
update_nv(&nv_copy, 34);
```

# A

## Series 6000 Design Checklists

This appendix includes a set of checklists, including chip connections, power supplies, PCB layout, and network cabling. These checklists help you ensure that products that you design for the Series 6000 chip meet the specifications described in this manual.

You can copy and freely distribute the contents of this appendix.

## Checklist 1: Series 6000 Chip Connections

This checklist applies to all Series 6000 chips, including FT 6000 Smart Transceivers and Neuron 6000 Processors.

Check When Complete	Item	Description
	CC1	The <b>VDD3V3</b> pins (8, 18, 29, 30, 41, and 42) are connected to $V_{DD3}$ (+3.3 V), as described in <i>Pin Connections</i> .
	CC2	The <b>VDD1V8</b> pins (6, 16, and 44) are connected to the <b>VOUT1V8</b> pin (27) only, as described in <i>Pin Connections</i> .  Do not connect an external 1.8 V source to any of the <b>VDD1V8</b> pins (6, 16, and 44). Connect these pins to the <b>VOUT1V8</b> pin (27) only. <b>Using an external 1.8 V source for the VDD1V8 pins voids the warranty for the chip, and can cause unpredictable and possibly irreparable results.</b>
	CC3	The <b>AVDD3V3</b> pin (31) are connected to analog $V_{DD3}$ (if separate from digital $V_{DD3}$ ) or to +3.3 V, as described in <i>Pin Connections</i> .
	CC4	The chip's pad (pin 49) is connected to logic ground, as described in <i>Pin Connections</i> .
	CC5	The <b>AGND</b> pin (33) is connected to analog ground (if separate from logic ground) or to logic ground, as described in <i>Pin Connections</i> .
	CC6	Decoupling capacitors are placed between $V_{DD3}$ and ground (0.1 $\mu$ F 10% 16V X7R) for pins 6, 8, 16, 18, 27, 29, 30, 31, 41, and 44. Each capacitor is placed directly adjacent to a $V_{DD3}$ pin, on the top layer of the PCB, with a short connection to ground, as described in <i>Pin Connections</i> .
	CC7	An additional decoupling capacitor is placed between $V_{DD3}$ and ground (0.1 $\mu$ F 10% 6.3V X7R) for the <b>VOUT1V8</b> pin (27). The capacitor is placed directly adjacent to the <b>VOUT1V8</b> pin, on the top layer of the PCB, with a short connection to ground, as described in <i>Pin Connections</i> .
	CC8	Unused I/O pins are pulled up to $V_{DD3}$ , or pulled down to ground, with a 10 k $\Omega$ resistor.
	CC9	The crystal or oscillator is connected to the <b>XIN</b> and <b>XOUT</b> pins (23 and 24), is 10 MHz, is 18 pF parallel resonant, and meets the accuracy requirements described in <i>Clock Requirements</i> .

Check When Complete	Item	Description
	CC10	Capacitors (30 pF 5% 50V NPO) are placed at the <b>XIN</b> and <b>XOUT</b> pins (23 and 24), as described in <i>Clock Requirements</i> . Each capacitor is placed directly adjacent to the <b>XIN</b> and <b>XOUT</b> pins, on the top layer of the PCB, with a short connection to ground.
	CC11	A feedback resistor (1 M $\Omega$ ) is added across the <b>XIN</b> and <b>XOUT</b> pins (23 and 24), as described in <i>Clock Requirements</i> .
	CC12	A series resistor (200 $\Omega$ ) is added at the <b>XOUT</b> pin (24), as described in <i>Clock Requirements</i> .
	CC13	Other than the crystal, the capacitors, series resistor, and the feedback resistor, there are no other connections to the <b>XIN</b> pin. The <b>XOUT</b> pin can optionally drive a CMOS buffer, as described in <i>Clock Requirements</i> .
	CC14	The <b>VDDPLL</b> pin (25) is connected to the <b>VOU1V8</b> pin (27) with an associated chip ferrite bead, as described in <i>Pin Connections</i> .
	CC15	The <b>GNDPLL</b> pin (26) is connected to GND with an associated chip ferrite bead, as described in <i>Pin Connections</i> .
	CC16	Stabilizing capacitors (0.01 $\mu$ F 10% 50V X7R and 0.1 $\mu$ F 10% 16V X7R) are added across the PLL pins (pins 25 and 26), as described in <i>Pin Connections</i> . Each capacitor is placed directly adjacent to the PLL pins, on the top layer of the PCB.
	CC17	The connections for the external memory parts meet the requirements specified in <i>Device Support</i>
	CC18	The JTAG <b>TCK</b> pin (19) includes a pullup resistor (4.99 k $\Omega$ ) to $V_{DD3}$ , as described in <i>Pin Connections</i> .

---

## Checklist 2: FT 6000 Smart Transceiver Connections

This checklist applies to FT 6000 Smart Transceivers.

Check When Complete	Item	Description
	FC1	All items in <i>Checklist 1: Series 6000 Chip Connections</i> .
	FC2	Environmental and electrical specifications are met, as described in the <i>FT 6000 Free Topology Smart Transceiver</i> data sheet.
	FC3	The FT-X3 Communications Transformer pins are connected as specified in <i>Transformer Electrical Connections</i> .
	FC4	The FT 6000 Smart Transceiver and the FT-X3 Communications Transformer are placed adjacent to one another on the same PCB.
	FC5	The connections for the <b>NETP</b> and <b>NETN</b> pins (34 and 32) match the requirements specified in <i>Connection for an FT 6000 Smart Transceiver</i> .
	FC6	The <b>CP4</b> pin (39) is connected to $V_{DD3}$ through a 4.99 k $\Omega$ pullup resistor, as shown in <i>Connection for an FT 6000 Smart Transceiver</i> .

---

## Checklist 3: Neuron 6000 Processor Connections

This checklist applies to Neuron 6000 Processors.

Check When Complete	Item	Description
	NC1	All items in <i>Checklist 1: Series 6000 Chip Connections</i> .
	NC2	Environmental and electrical specifications are met, as described in the <i>Neuron 6000 Processor</i> data sheet.
	NC3	The connections for the <b>CP0..CP4</b> pins (32, 34, 37, 38, and 39) match the requirements specified in <i>Connection for a Neuron 6000 Processor</i> .

---

## Checklist 4: Power Supply

This checklist applies to all Series 6000 chips, including FT 6000 Smart Transceivers and Neuron 6000 Processors.

Check When Complete	Item	Description
	PS1	$V_{DD3} = 3.3V \pm 0.3V$ over the full device temperature range and device application current range (including any ripple).
	PS2	Any ripple on $V_{DD3}$ is $\leq 50 \text{ mV}_{p-p}$ , measured with a 20 MHz bandwidth.
	PS3	For host-based devices (ShortStack devices), the rise time of $V_{DD3}$ at power-up meets the requirements of the host microprocessor (see the appropriate host microprocessor data sheet – the maximum allowable risetime is often listed).



## Checklist 5: Device PCB Layout

This checklist applies to all Series 6000 chips, including FT 6000 Smart Transceivers and Neuron 6000 Processors.

Check When Complete	Item	Description
	LO1	Your design incorporates a “star ground” layout design, with the network connector, coupling circuit, power supply input, and externally-accessible I/Os all grouped near each other along one edge (or two adjacent edges) of the PCB.
	LO2	If your device has a metal enclosure, the enclosure is tied to the center of the star ground through a low inductance connection (optionally with a low-inductance DC blocking capacitor in series).
	LO3	For 4-layer PCBs, the internal ground plane is used to connect the center of the star ground out to the ground connections of the other functional blocks.  For 2-layer PCBs, ground pours on the bottom and top layers are used to connect the center of the star ground out to the ground connections of the other functional blocks.
	LO5	For FT 6000 Smart Transceiver devices, the EMC keepout area shown in <b>Figure 30</b> has no traces or planes in the area shown, except for the connections from the NETA and NETB traces through the coupling capacitors and into the communication transformer.
	LO6	There is a low-inductance ground path from the Series 6000 chip back to the center of the star ground, to ensure that ESD and surge transients clamped inside the Series 6000 chip have a good return path back off of the PCB without going through any sensitive circuitry.
	LO7	If the device has a host microprocessor or any other digital circuitry that could generate RF noise, that circuitry is kept away from the network cable, power cable, and any I/O cables.
	LO8	The leakage capacitance to external metal surfaces from high frequency circuit traces is controlled with guard traces.
	LO9	The FT-X3 Communications Transformer PCB layout matches <b>Figure 52</b> .

---

## Checklist 6: Network Cabling and Termination

This checklist applies to FT 6000 Smart Transceivers.

Check When Complete	Item	Description
	NT1	The LONWORKS network uses one of the approved wire types described in Chapter 5, <i>Network Cabling and Connections for FT Devices</i> .
	NT2	The LONWORKS network uses the appropriate termination, as described in <i>Cable Termination and Shield Grounding</i> .

---

## Checklist 7: Device Programming

This checklist applies to all Series 6000 chips, including FT 6000 Smart Transceivers and Neuron 6000 Processors.

Check When Complete	Item	Description
	PG1	For FT 6000 Smart Transceivers, TP/FT-10 is used as the channel definition in the development tool.  For Neuron 6000 Processors, the appropriate channel type is specified.
	PG2	The device's hardware template defines the appropriate clock multiplier for the Series 6000 chip's PLL to specify the system clock rate.



# B

## Qualified TP/FT-10 Cable Specifications

This appendix describes generic cable specifications for cables that Echelon has qualified to work with TP/FT-10 channels.

---

## Introduction

This appendix documents generic cable specifications for cables that Echelon has qualified to work with TP/FT-10 channels. Specific vendors and their cables are cited only to highlight the variety of cable types available that meet these generic specifications; other vendors may also meet the required specifications.

---

## Qualified Cables

Echelon has qualified five cable types that are available from a variety of different vendors. Table 35 describes these cables.

**Table 35.** Qualified Cables

Cable Type	AWG	Diameter	Comment
TIA 568A Category 5 or Category 6 cable	24 AWG	0.5 mm	Widely available, and can be found as part of structured cabling systems, such as the CommScope® Inc. Systimax® Structured Connectivity Solutions (originally developed by AT&T® Bell Laboratories).
NEMA Type 4 cable	16 AWG	1.3 mm	Available with a broad range of options, including stranded or solid, 1 or 2 pairs per cable, shielded or unshielded, and plenum or PVC.  <i>See also NEMA Type 4 Cable Specifications.</i>
Belden 8471 cable	16 AWG	1.3 mm	<i>See 16 AWG (1.3 mm) “Generic” Cable Specifications.</i>
Belden 85102 cable	22 AWG	0.65 mm	<i>See 16 AWG (1.3 mm) “Generic” Cable Specifications.</i>
J-Y(ST)Y 2x2x0.8 cable	20.4 AWG	0.8 mm	Available only in Europe. See the <i>Junction Box and Wiring Guidelines for Twisted Pair LONWORKS Networks</i> engineering bulletin (005-0023-01) for more information.

**Notes:**

- AWG: American wire gauge. See *ASTM B258 - 02(2008) Standard Specification for Standard Nominal Diameters and Cross-Sectional Areas of AWG Sizes of Solid Round Wires Used as Electrical Conductors* ([www.astm.org/Standards/B258.htm](http://www.astm.org/Standards/B258.htm)) for a definition of the wire gauges.
- NEMA: National Electrical Manufacturers Association. [www.nema.org](http://www.nema.org)
- TIA: Telecommunications Industry Association. [www.tiaonline.org](http://www.tiaonline.org)

The *Junction Box and Wiring Guidelines for Twisted Pair LONWORKS Networks* engineering bulletin (005-0023-01) provides a list of cable vendors for each cable type. This document is available from the Echelon website ([www.echelon.com](http://www.echelon.com)).

---

## Category 5 and 6 Cable Specifications

The specification for the Telecommunications Industry Association *Commercial Building Telecommunications Cabling Standard* (ANSI/TIA/EIA-568-A-95) is available from Information Handling Services (IHS) at [global.ih.com](http://global.ih.com).

---

## NEMA Type 4 Cable Specifications

The Type 4 cable specification used by Echelon, and as originally defined by the National Electrical Manufacturers Association (NEMA), differs from the Category IV specification proposed by the Electronic Industries Association/Telecommunication Industry Association (EIA/TIA).

Tables 36 through Table 39 list the Type 4 cable specifications. In the tables, specifications apply to shielded or unshielded 22 AWG (0.65 mm) cable, unless listed otherwise.

**Table 36.** General Specifications

Specification	Value
<b>DC Resistance</b> (ohms per 1000 feet at 20 °C) maximum for a single copper conductor regardless of whether it is solid or stranded and is or is not metal-coated	18 [for 22 AWG (0.65 mm) cable] 28.6 [for 24 AWG (0.5 mm) cable]
<b>DC Resistance Unbalance</b> (percent) maximum	5
<b>Mutual Capacitance of a Pair</b> (pF/foot) maximum	17
<b>Pair-to-Ground Capacitance Unbalance</b> (pF/1000 feet) maximum	1000

**Table 37.** Impedance Characteristics

Frequency	Impedance (Ohms)
772 kHz	102 ±15% (87-117)
1.0 MHz	100 ±15% (85-115)
4.0 MHz	100 ±15% (85-115)
8.0 MHz	100 ±15% (85-115)
10.0 MHz	100 ±15% (85-115)
16.0 MHz	100 ±15% (85-115)
20.0 MHz	100 ±15% (85-115)

**Table 38.** Attenuation (dB per 1000 feet at 20 °C) Maximums

Frequency	Attenuation (dB per 1000 feet at 20 °C)
772 kHz	4.5 [for 22 AWG (0.65 mm) cable] 5.7 [for 24 AWG (0.5 mm) cable]
1.0 MHz	5.5 [for 22 AWG (0.65 mm) cable] 6.5 [for 24 AWG (0.5 mm) cable]
4.0 MHz	11.0 [for 22 AWG (0.65 mm) cable] 13.0 [for 24 AWG (0.5 mm) cable]
8.0 MHz	15.0 [for 22 AWG (0.65 mm) cable] 19.0 [for 24 AWG (0.5 mm) cable]
10.0 MHz	17.0 [for 22 AWG (0.65 mm) cable] 22.0 [for 24 AWG (0.5 mm) cable]
16.0 MHz	22.0 [for 22 AWG (0.65 mm) cable] 27.0 [for 24 AWG (0.5 mm) cable]
20.0 MHz	24.0 [for 22 AWG (0.65 mm) cable] 31.0 [for 24 AWG (0.5 mm) cable]



**Table 39.** Worst-Pair Near-End Crosstalk (dB) Minimums

Specification	Value (dB)
772 kHz	58
1.0 MHz	56
4.0 MHz	47
8.0 MHz	42
10.0 MHz	41
16.0 MHz	38
20.0 MHz	36

Values in Table 39 are shown for informational use only. The minimum near-end cross talk (NEXT) coupling loss for any pair combination at room temperature is to be greater than the value determined using the following formula for all frequencies in the range of 0.772 MHz to 20 MHz for a length of 1000 feet (305 m):

$$NEXT(F_{MHz}) > NEXT(0.772) - 15 * \log\left(\frac{F_{MHz}}{0.772}\right)$$

## 16 AWG (1.3 mm) “Generic” Cable Specifications

Tables 40 and 41 describe the specifications for the 16 AWG (1.3 mm) generic cable qualified by Echelon for use with TP/FT-10 networks. The generic single twisted pair is stranded (19 x 29) with tinned copper.

The conditions listed in the tables are specified according to *ASTM D4566 - 05e1 Standard Test Methods for Electrical Performance Properties of Insulations and Jackets for Telecommunications Wire and Cable* ([www.astm.org/Standards/D4566.htm](http://www.astm.org/Standards/D4566.htm)).

**Table 40.** General Specifications

Specification	Minimum	Typical	Maximum	Condition
DC resistance, each conductor	14.0	14.7	15.5 Ω/km	20 °C
DC resistance, unbalance	—	—	5%	20 °C
Mutual capacitance	—	—	55.9 nF/km	—
Characteristic impedance	92	100	108	64 kHz to 1 MHz

**Table 41.** Attenuation and Propagation Delay Characteristics

<b>Characteristic</b>	<b>Maximum</b>	<b>Condition</b>
Attenuation		20 °C
20 kHz	1.3 dB/km	
64 kHz	1.9 dB/km	
78 kHz	2.2 dB/km	
156 kHz	3.0 dB/km	
256 kHz	4.8 dB/km	
512 kHz	8.1 dB/km	
772 kHz	11.3 dB/km	
1000 kHz	13.7 dB/km	
Propagation delay	5.6 ns/m	78 kHz

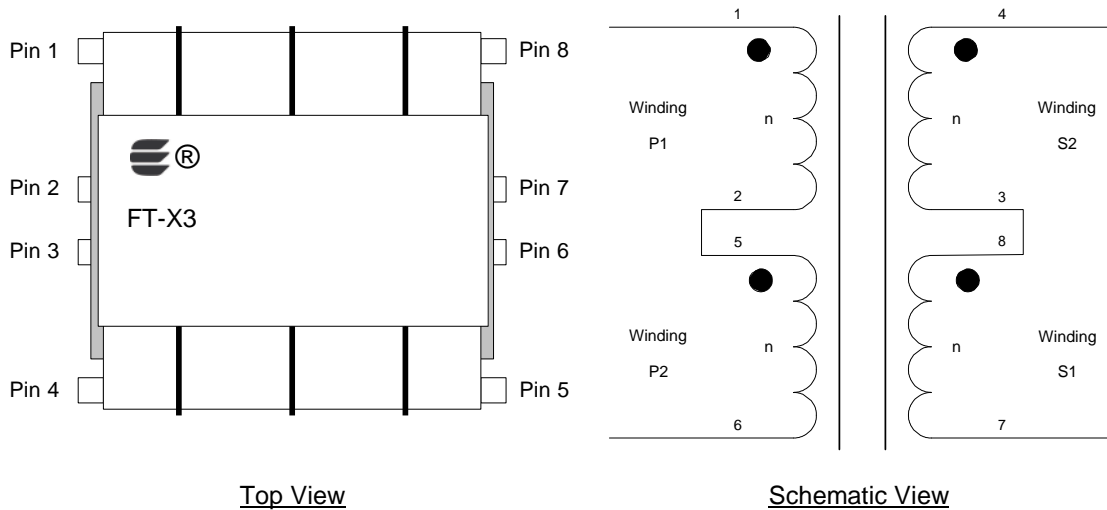
# C

## **FT-X3 Communications Transformer**

This appendix describes the FT-X3 Communications Transformer, including its pinout, electrical connections, and pad layout.

## Transformer Pinout

**Figure 49** shows the pinout for the FT-X3 Communications Transformer and the equivalent electrical schematic. The FT-X3 Communications Transformer is rotationally symmetric; thus, the package does not mark pin 1. The wiring connections shown in *Figure 47* are made on the PCB, as described in *Transformer Pad Layout*. *Table 42* lists the pin assignments for the FT-X3 Communications Transformer.



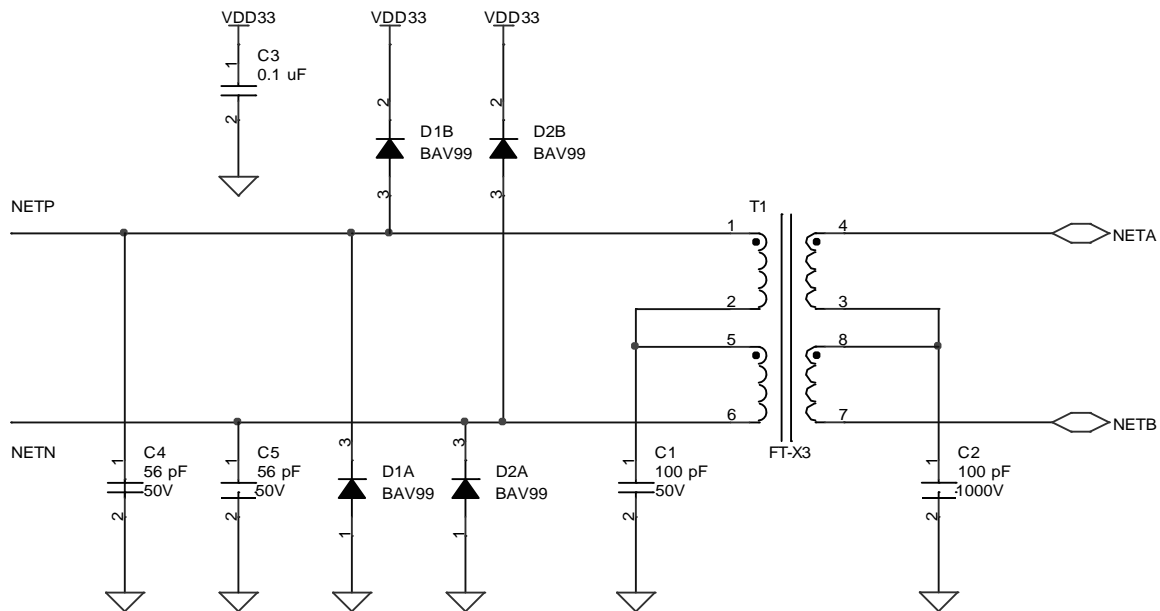
**Figure 47.** FT-X3 Communications Transformer Pinout Diagram and Schematic

**Table 42.** FT-X3 Communications Transformer Pin Assignments

Name	Pin Number	Description
NETP	1	NETP connection from FT 6000 Smart Transceiver
CTP1	2	Center tap for primary winding 1
CTS2	3	Center tap for secondary winding 2
NETA	4	NETA connection to LONWORKS network
CTP2	5	Center tap for primary winding 2
NETN	6	NETN connection from FT 6000 Smart Transceiver
NETB	7	NETB connection to LONWORKS network
CTS1	8	Center tap for secondary winding 1

## Transformer Electrical Connections

Figure 48 shows the electrical connections for the FT-X3 Communications Transformer. The NETP and NETN signals represent connections to the FT 6000 Smart Transceiver NETP and NETN pins (32 and 34). The NETB and NETA ports represent the connections to the LONWORKS network, as shown in Figure 49.

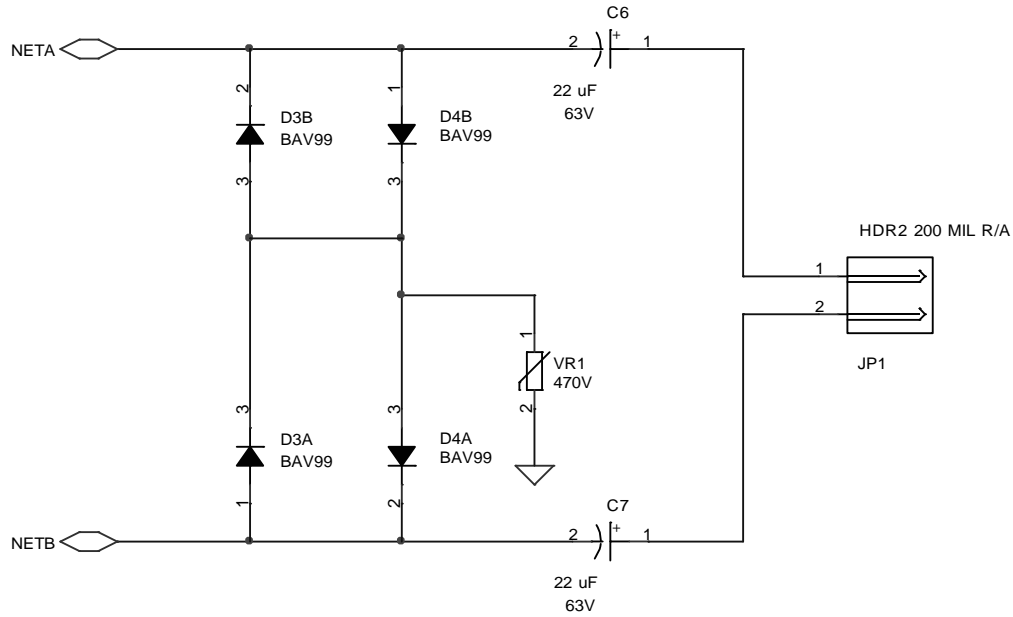


**Figure 48.** FT-X3 Electrical Connections

In the figure, the diodes D1 and D2 are ESD transient clamping diodes. Capacitors C1 and C2 are optional center-tap capacitors for the primary and secondary sides of the transformer. You can tune the values for C1 and C2 based on required EMC performance. Capacitor C3 provides decoupling for the ESD clamp diodes. Capacitors C4 and C5 provide common-mode noise immunity for compliance with EN61000-4-6 Level 3.

Note that the electrical connections for the FT-X3 Communications Transformer shown in **Figure 50** differ from the connections shown in the schematic for the FT 6000 Evaluation Board that is included with the IzoT NodeBuilder Development Tool. The connections described in this data book are the *preferred* connections for the FT-X3 Communications Transformer.

**Figure 51** shows the electrical connections for the FT network connector to the LONWORKS network.



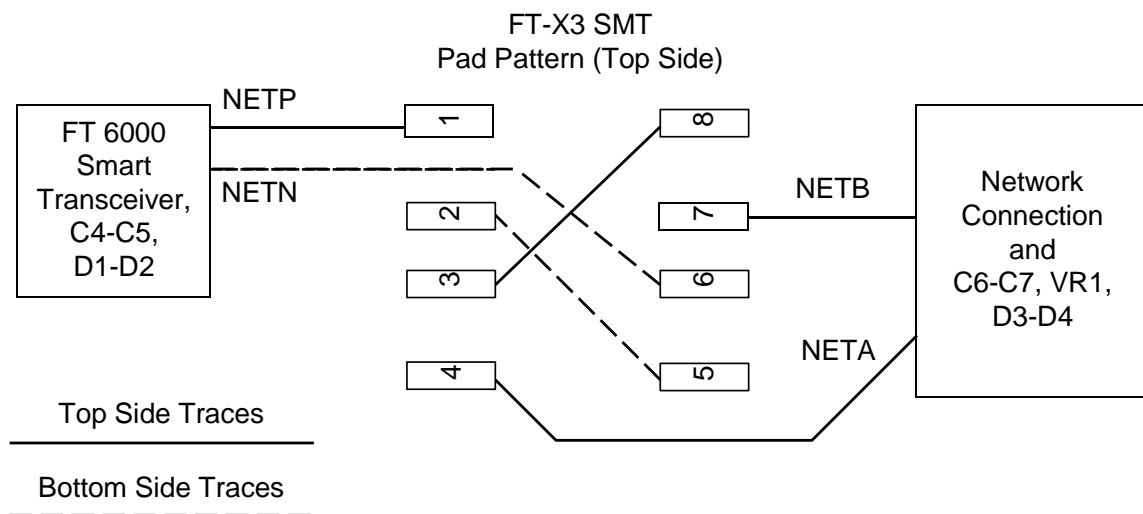
**Figure 49.** FT Network Electrical Connections

In the figure, the diodes D3 and D4 are differential network clamping diodes. Capacitors C6 and C7 are DC blocking capacitors, 22  $\mu$ F, 63 V, polarized electrolytic aluminum. Varistor VR1 is 470 V, 5 mm. See *Connection for an FT 6000 Smart Transceiver* for more information about the network connection.

## Transformer Pad Layout

See the FT 6000 Free Topology Smart Transceiver data sheet (for a description of the pad layout for the FT-X3 Communications Transformer).

Figure 50 shows the recommended PCB trace layout for the FT-X3 Communications Transformer for a two-layer PCB.

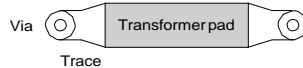


**Figure 50.** Recommended PCB Layout for FT-X3 Transformer

Notes for the figure:

- Maintain a minimum distance of 2 mm between a routed trace and any of the transformer pads or traces. This distance is especially important for the network pins (3, 4, 7, and 8) to maintain EMC compliance. The primary and secondary traces should be kept away from each other as much as possible.
- If you use center-tap capacitors, place them near pin 2 (Primary) and pin 8 (Secondary).
- Vias and other PCB features are not shown. Use standard practices for vias and trace widths.
- The component callout letters refer to the callouts used in **Figure 50** and **Figure 51**.

**Recommendation:** Add vias to the ends of each of the pin pad connections (just outside the SMT pad rectangles) to provide additional mechanical support for the transformer, as shown in Figure 51. The figure shows the pad trace extended to the via at each end, and slightly narrowed to distinguish the trace from the pad; use standard layout rules to determine the size and distances for the traces.



**Figure 51.** Adding Vias to the Transformer Pad Layout





# D

## Handling and Manufacturing Guidelines

This appendix describes guidelines for handling and manufacturing devices that use the Neuron 6000 Processor or FT 6000 Smart Transceiver, including soldering profiles and ESD handling guidelines.

---

## Application Considerations

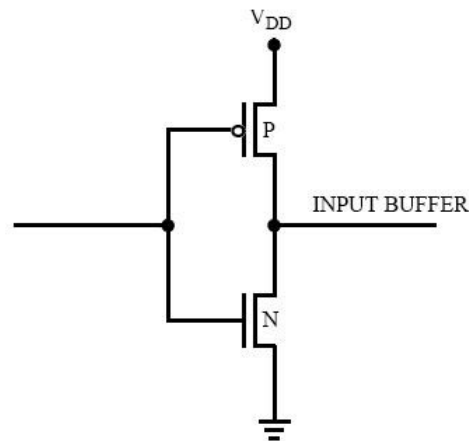
This section describes application considerations for design and manufacturing of LONWORKS devices.

---

### *Termination of Unused Pins*

Because Series 6000 devices are CMOS devices, you must terminate all unused input pins, including undeclared or unconnected I/O pins that are configured as inputs and including three-state pins, to assure proper operation and reliability.

Figure 52 shows a CMOS inverter representative of circuitry found on CMOS input pins. When the input is logic zero, the P-channel transistor is *on* (conducts), and the N-channel transistor is *off*. When the input is a logic one, the P-channel transistor is *off*, and the N-channel transistor is *on*. These transistors are linear devices with relatively broad switch points. As the input transitions through the mid-supply region, there is a period of time when both transistors are conducting. With fast rise-time digital signals at the input, this period is very short. When the inverter is out of the linear region, there is very little current flow. This effect is the reason that the overall current drain of a CMOS device is directly proportional to the switching speed. Almost all the current consumption is by transistors passing through the linear region and charging and discharging of internal capacitances. If a pin is configured as an input or three-state, then the input can oscillate because of power supply noise or it can float to the mid-supply region, which can result in higher current consumption. Current design techniques have made latch-up due to floating input unlikely, but it is good design practice to terminate unused I/O pins that are not configured (high impedance) or are configured as inputs.



**Figure 52.** CMOS Inverter

The best method to terminate unused I/O pins is with an individual pull-up or pull-down resistor for each unused pin. Other, less desirable, methods include:

- Connecting unused input pins to each other and then to a common termination point. This cost- and space-effective method has the disadvantage of not allowing individual pin configuration later and has the possibility of contention if the pins are later declared as outputs.

- Connecting individual unused I/O pins directly to GND or to  $V_{DD}$ . This method is not recommended in case of software error and because of the possibility of output declaration to an opposing state.
- Declaring unused pins as outputs.

Thus, you should never connect a pin that is capable of being configured as an output to another such pin or directly to GND or to  $V_{DD}$ .

---

## Avoidance of Damaging Conditions

All integrated circuit devices can be damaged or destroyed by exceeding specified voltage and environmental limits. These limits are conservative to ensure reliable operation within the conditions specified.

The maximum peak temperature for a Series 6000 chip is 260 °C. See *Recommended Solder Profile*, and consult the data sheet of the solder manufacturer for recommendations on the optimum reflow profile. The actual reflow profile that you choose should consider these peak temperature limitations.

Most potentially destructive AC waveforms fall into one of two categories:

- High-voltage (10 kV to 25 kV), low-energy, spikes due to ESD discharge that usually last no longer than 100 ns. ESD modeling has shown that the human body can generate and discharge electrostatic voltages of up to 12 kV.
- Lower-voltage, higher energy, transients that can last for several hundred microseconds or more, that can be caused by capacitive coupling of lightning or by inductive load sources.

Different protection devices for these destructive waveforms must be implemented, depending on what is anticipated in the operating environment. Failure modes can be quantified and protective precautions taken to avoid product malfunction. This could be PC board layout-related or could involve the use of external protection devices. External protection is required for products that are subject to human contact or where interfaces to other equipment might be encountered. See Chapter 4, *Design and Test for Electromagnetic Compatibility*, for more information about ESD protection.

Many factors, including ambient temperature and semiconductor lot-to-lot processing variations, can influence the effect of illegal conditions on a Series 6000 chip. The ground pins are internally connected to the substrate of the silicon die and are the reference point for all voltages. The Series 6000 chip functions for  $V_{DD}$  are connected to the positive supply pins. In limited temperature range environments, the device might operate over a wider  $V_{DD}$  ranges, with timing, drive, FT transceiver, and other specifications not met. There might also be some adverse effects on gate oxides from long-term exposures to  $V_{DD}$  greater than 3.3 V.

For Series 6000 chips, do not connect an external 1.8 V source to any of the **VDD1V8** pins (6, 16, and 44). Connect these pins to the **VOUT1V8** pin (27) only. **Using an external 1.8 V source voids the warranty for the chip, and can cause unpredictable and possibly irreparable results.**

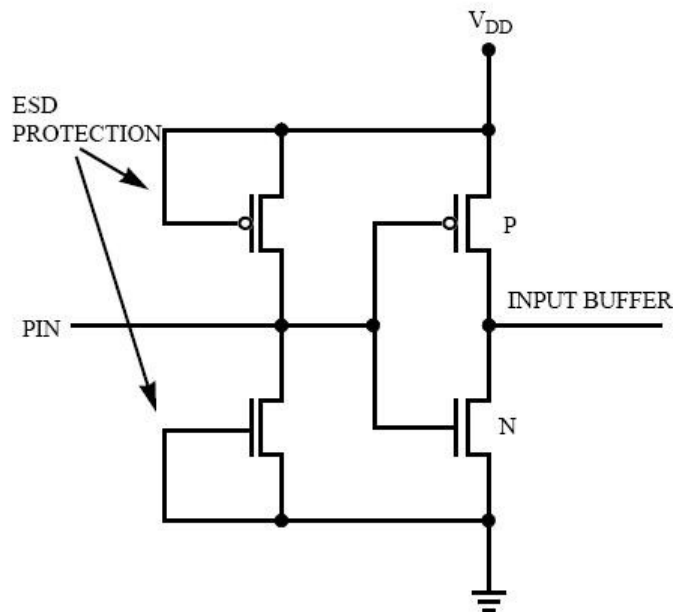
Two additional damage mechanisms that are resident in CMOS chips include *zap* and *latch-up*:

- Zap refers to damage caused by exposure to very-high-voltage static electricity. This damage usually appears as breakdown of the relatively thin oxide layers, which

causes leakage or shorts. Often secondary damage occurs after an initial zap failure causes a short.

- Latch-up refers to a usually catastrophic condition that is caused by turning on a parasitic, bipolar, silicon-controlled rectifier (SCR). A latch-up is formed by N and P regions in the layout of the integrated circuit, which act as the collector, base, and emitter of parasitic transistors. Bulk resistance of silicon in the wells and substrate acts as resistors in the SCR circuit. Application of voltages to pins above  $V_{DD} + 0.3\text{ V}$  or below  $GND - 0.3\text{ V}$ , in conjunction with enough current to develop voltage drops across the parasitic resistors, can cause the SCR to turn on. After it is on, the SCR can be turned off only by removal of all power and applied voltages. The low on-impedance of the SCR circuit can overheat and destroy the chip.

Figure 53 shows the MOS circuitry for a digital input-only pin. The gates of the input buffer are very high impedance for all voltages that would ever be applied to the pin. Protection is implemented with a P-channel transistor that acts as a diode to  $V_{DD}$  and an N-channel transistor that acts as a diode to GND. Allowing a pin to float or be driven to a mid-supply level can result in both the N- and P-channel devices in the input buffer simultaneously being partially on, which can cause excess current and noise for the  $V_{DD}/GND$  power supply. If a digital input is driven above  $V_{DD}$ , the pseudo-diode will conduct, protecting the input. As the current is increased to high levels (100 mA), damage can result.



**Figure 53.** Digital Input

Figure 54 shows the CMOS circuitry for a digital I/O pin.

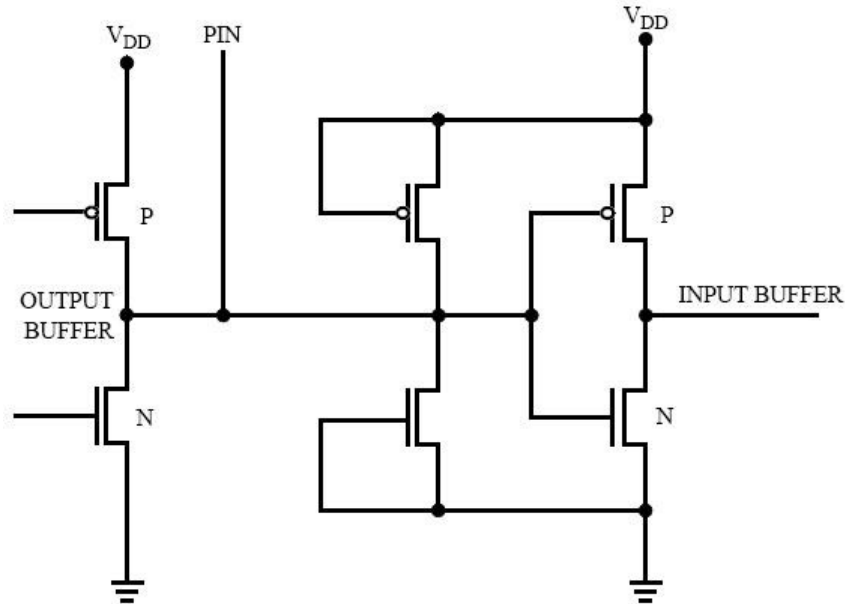


Figure 54. Digital I/O

---

## Electrostatic Discharge Design Guidelines

There are many ways to deal with ESD, including:

- Divert or limit energy from points of contact to circuitry.
- Start with a series of electromagnetic interference (EMI) ferrites or resistors for high frequency filtering.
- Use diodes, transient voltage suppressors (such as, MOSorbs or transorbs) for high-speed clamping.
- Use capacitors to protect critical inputs.
- Use good power distribution.
- Use a separate, low-impedance, ESD ground path to divert energy from electronics (for example, the star-ground strategy described in Chapter 4, *Design and Test for Electromagnetic Compatibility*).

**Note:** The impedance of a wire at 300 MHz is approximately 20  $\Omega$ /cm. Use a conductor with less than or equal to 3:1 length:width ratio.

---

## Power Supply, Ground, and Noise Considerations

Some of the most important considerations for PCB layout concern how to manage noise. Noise can come from the power supply, from digital circuitry on the device, and from digital signals that couple to analog signals. Best practices for PCB layout methods to help prevent noise-induced problems include:

- Keep digital signals as far away from analog signals as possible.

- Use short, low-inductance, traces for the analog circuitry to reduce inductive, capacitive, and radio frequency (RF) noise sensitivities.
- Use short, low-inductance, traces for the digital circuitry to reduce inductive, capacitive, and radio frequency (RF) radiated noise.
- Connect bypass capacitors between the  $V_{DD}$  and GND pairs with minimal trace length. These capacitors help supply the instantaneous currents of the digital circuitry, in addition to decoupling the noise that can be generated by other sections of the device or by other circuitry on the power supply.
- Use short, wide, low-inductance, traces to connect all of the GND ground pins together. Depending on the application, a double-sided PCB with a ground plane under the device that connects all of the digital and analog GND pins together could be a good grounding method. A multilayer PCB with a ground plane that connects all of the digital and analog GND pins together would be the optimal ground configuration. These methods result in the lowest resistance and the lowest inductance in the ground circuit, which is important to reduce voltage spikes in the ground circuit resulting from the high-speed digital current spikes. Suppressing these voltage spikes on the integrated circuit is the reason for multiple GND leads.
- Use short, wide, low-inductance, traces to connect all of the  $V_{DD}$  power supply pins together. Depending on the application, a double-sided PCB with  $V_{DD}$  bypass capacitors to the ground plane under the device can complete the low-impedance coupling for the power supply. For a multilayer PCB with a power plane, connecting all of the digital and analog  $V_{DD}$  pins to the power plane would be the optimal power distribution method. The integrated circuit layout and packaging considerations for the 3.3  $V_{DD}$  power circuit are essentially the same as for the ground circuit.

---

## *Decoupling Capacitors*

To absorb switching spikes, which can introduce noise problems, the following CMOS devices should be bypassed with good quality 0.022  $\mu\text{F}$  to 0.33  $\mu\text{F}$  decoupling capacitors:

- Every device that drives a bus on which outputs switch simultaneously.
- All synchronous counters.
- Devices used as oscillator elements.
- Schmitt-trigger devices with slow input rise and fall times. The slower the rise and fall time, the larger the bypass capacitor. Lab experimentation is suggested.

Bypass capacitors should be distributed over the circuit board. In addition, boards could be decoupled with a 1  $\mu\text{F}$  capacitor. You should also ensure low-impedance paths to and from logic devices in board layouts.

---

## **Board Soldering Considerations**

This section describes PC board soldering considerations for design and manufacturing of Series 6000 devices.

---

## *Recommended Solder Profile*

Follow the general guidelines described in IPC/JEDEC Standard J-STD-020D.1 when soldering Series 6000 chips to PCBs. This standard includes information for classification reflow profiles. All Series 6000 chips comply with the European Union Restriction of

Hazardous Substances (RoHS) Directive (2002/95/EC), thus their profiles use the lead-free assembly, with a peak temperature  $T_p$  of 260 °C.

---

## Soldering Surface Mount (SMT) Parts

Table 43 lists the maximum reflow temperature for surface mount (SMT) parts. In all cases, consult the solder manufacturer's data sheet for recommendations on optimum reflow profile. The actual reflow profile chosen should consider the peak temperature limitations.

**Table 43.** Peak Temperatures for Surface Mount Parts

Product	RoHS Compliant	Model Number	Peak Temperature
FT 6000 Free Topology Smart Transceiver	Yes	14235R	260 °C
Neuron 6000 Processor	Yes	14305R	260 °C
FT-X3 Communications Transformer	Yes	14255R	245 °C

As measured according to the IPC/JEDEC Standard J-STD-020D.1, Series 6000 chips have a Level 3 Classification. The recommended soldering technique for Series 6000 chips is surface mount reflow. Soldering techniques that involve immersing the entire part are not recommended. Consult the solder manufacturer's datasheet for recommendations on optimum reflow profile.

Dry pack is a process that slowly bakes moisture from the surface mount technology package and seals it into a dry pack bag to shield the unit from moisture in the atmosphere. The exterior of the bag is marked with a label that indicates that the devices are moisture sensitive and is marked with the date that the bag was sealed (there is a one year shelf life for such devices).

There is a limited amount of time to use surface-mount devices after they are removed from the dry pack. Before surface mounting, packages should not be out of the dry pack longer than 168 hours at  $\leq 60\%$  relative humidity and  $\leq 30$  °C. If the units have not been shipped dry pack or have been unpacked for too long, then units must be baked at 125 °C for 12 hours prior to board soldering. If this is not done, some percentage of the units can exhibit destructive failures or latent failures after the soldering process.

---

## General ESD Handling Guidelines

All complementary metal-oxide-semiconductor (CMOS) devices have an insulated gate that is subject to voltage breakdown. The high-impedance gates on the devices are protected by on-chip networks. However, these on-chip networks do not make the chip immune to ESD. Laboratory tests show that devices can fail after one very high voltage discharge. They can also fail due to the cumulative effect of several discharges of lower potential.

Static-damaged devices behave in various ways, depending on the severity of the damage. The most severely damaged are the easiest to detect because the input or output has been completely destroyed and is shorted to  $V_{DD}$ , shorted to GND, or is open-circuited. As a result of this damage, the device no longer functions. Less severe cases are more difficult to detect

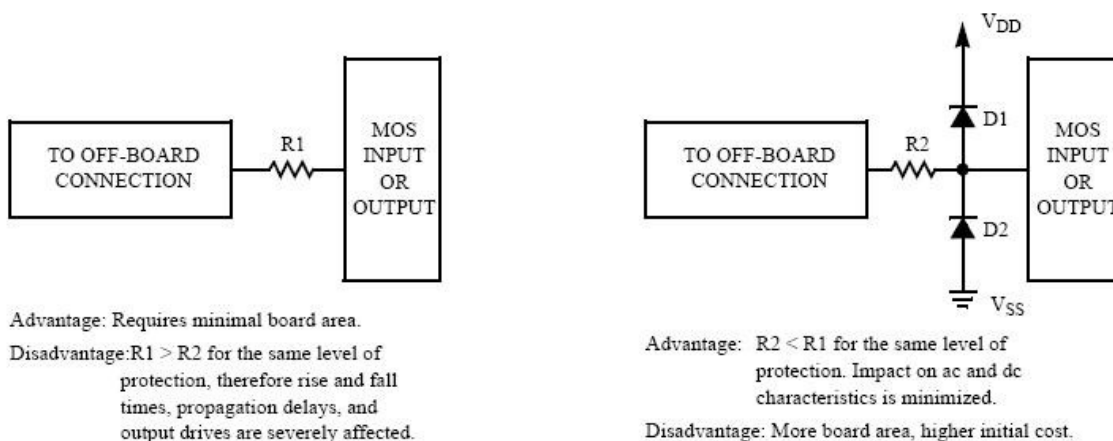
because they appear as intermittent failures or as degraded performance. Static damage can often increase leakage currents.

CMOS devices are not immune to large static voltage discharges that can be generated during handling. For example, static voltages generated by a person walking across a waxed floor have been measured in the 4 kV – 15 kV range (depending on humidity, surface conditions, and so on). Therefore, you should observe the following general precautions:

1. Do not exceed the maximum ratings specified by the data sheet.
2. All unused device inputs should be connected to  $V_{DD}$  or GND.
3. All low-impedance equipment (for example, pulse generators) should be connected to CMOS inputs only after the device is powered up. Similarly, this type of equipment should be disconnected before power is turned off.
4. A circuit board containing CMOS devices is merely an extension of the device, and the same handling precautions apply. Contacting connectors wired directly to devices can cause damage. Plastic wrapping should be avoided. When external connections to a PC board address pins of CMOS integrated circuits, a resistor should be used in series with the inputs or outputs. The limiting factor for the series resistor is the added delay caused by the time constant formed by the series resistor and input capacitance. This resistor will help limit accidental damage if the PC board is removed and is brought into contact with static-generating materials. For convenience, Figure 55 describes equations for added propagation delay and rise-time effects due to series-resistance size.
5. All CMOS devices should be stored or transported in materials that are antistatic. Devices must not be inserted into conventional plastic “snow,” Styrofoam®, or plastic trays. Devices should be left in their original container until ready for use.
6. All CMOS devices should be placed on a grounded bench surface and operators should ground themselves prior to handling devices, because a worker can be statically charged with respect to the bench surface. Wrist straps in contact with skin are strongly recommended. See Figure 56.
7. Nylon or other static-generating materials should not come in contact with CMOS circuits.
8. If automatic handling is being used, high levels of static electricity can be generated by the movement of devices, belts, or boards. Reduce static build-up by using ionized air blowers or room humidifiers. All parts of machines that come into contact with the top, bottom, and sides of IC packages must be grounded metal or other conductive material.
9. Cold chambers that use  $CO_2$  for cooling should be equipped with baffles, and devices must be contained on or in conductive material, or soldered onto a PCB.
10. When lead-straightening or hand-soldering is necessary, provide ground straps for the apparatus used and be sure that soldering ties are grounded.
11. The following precautions apply during wave-solder operations:
  - a. The solder pot and conductive conveyor system of the wave-soldering machine must be grounded to an Earth ground.
  - b. The loading and unloading work benches should have conductive tops which are grounded to an Earth ground.
  - c. Operators must comply with precautions previously explained.



- d. Completed assemblies should be placed in antistatic containers prior to being moved to subsequent stations.



NOTE: These networks are useful for protecting the following:

- a. digital inputs and outputs
- b. analog inputs and outputs
- c. three-state outputs
- d. bidirectional (I/O) ports

**Equation 1 – Propagation Delay vs. Series Resistance**

$$R \approx \frac{t}{C \cdot k}$$

where:

- R = the maximum allowable series resistance in ohms
- t = the maximum tolerable propagation delay in seconds
- C = the board capacitance plus the input capacitance of the driven device in farads
- k = 0.33 for the TTL input levels (switch point = 1.3 V)

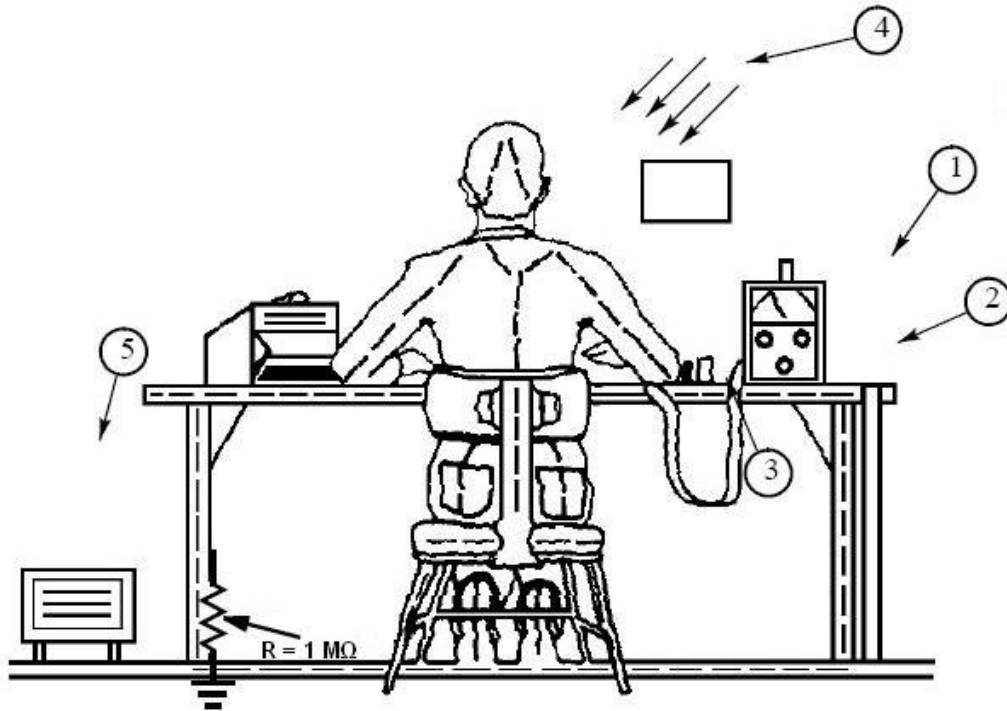
**Equation 2 – Rise Time vs. Series Resistance**

$$R \approx \frac{t}{C \cdot k}$$

where:

- R = the maximum allowable series resistance in ohms
- t = the maximum rise time per data sheet in seconds
- C = the board capacitance plus the input capacitance of the driven device in farads
- k = 2.3 for other devices

**Figure 55.** Networks for Minimizing ESD and Reducing CMOS Latch-Up Susceptibility



**Figure 56.** Typical Manufacturing Work Station

Notes for Figure 56:

1. 1/16-inch conductive sheet stock covering bench-top work area.
2. Ground strap.
3. Wrist strap in contact with skin.
4. Static neutralizer (ionized air blower directed at work). Primarily for use in areas where direct grounding is impractical.
5. Room humidifier. Primarily for use in areas where the relative humidity is less than 45%. Caution: building heating and cooling systems usually dry the air, which causes the relative humidity inside a building to be less than outside humidity.

The following steps should be observed during board cleaning operation:

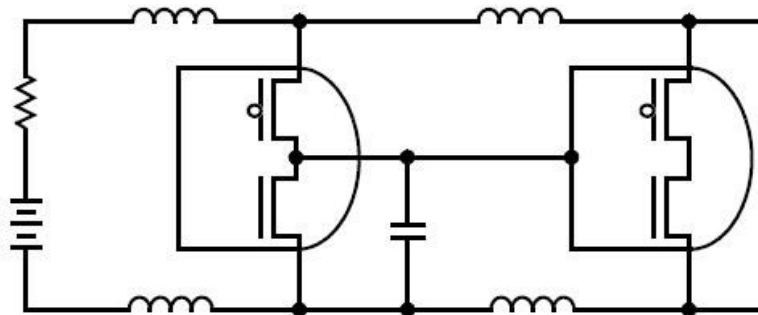
1. Vapor degreasers and baskets must be grounded to an Earth ground. Operators must likewise be grounded.
2. Brush or spray cleaning should not be used.
3. Assemblies should be placed into the vapor degreaser immediately upon removal from the antistatic container.
4. Cleaned assemblies should be placed in antistatic containers immediately after removal from the cleaning basket.
5. High-velocity air movement or application of solvents and coatings should be employed only when module circuits are grounded and a static eliminator is directed at the module. The use of static-detection meters for line surveillance is highly recommended.
6. The use of static-detection meters for line surveillance is highly recommended.

7. Equipment specifications should alert users to the presence of CMOS devices and require familiarization with this specification prior to performing any kind of maintenance or replacement of devices or modules.
8. Do not insert or remove CMOS devices from test sockets with power applied. Check all power supplies to be used for testing devices to be certain there are no voltage transients present.
9. Double-check the equipment setup for proper polarity of voltage before conducting parametric or functional testing.
10. Do not recycle shipping rails. Continuous use causes deterioration of their antistatic coating.
11. Wrist straps and equipment logs should be maintained and audited on a regular basis. Wrist straps malfunction and the malfunction can go unnoticed. Also, equipment gets moved from time to time and grounds might not be reconnected properly.

---

## Power Distribution and Decoupling Capacitors

Inductance in the power distribution creates noise during switching transients.



**Figure 57.** Inductance Creates Noise

For example, a 200 nH inductor with 25 mA and 5 ns surge characteristic can generate 1 V in noise:

$$V_{noise} = L \frac{dI}{dt}$$

If  $L = 200 \text{ nH}$ ,  $dI = 25 \text{ mA}$ ,  $dt = 5 \text{ ns}$ , then  $V_{noise} = 200 \text{ nH} * (25 \text{ mA} / 5 \text{ ns}) = 1 \text{ V}$ .

---

## Recommended Bypass Capacitor Placement

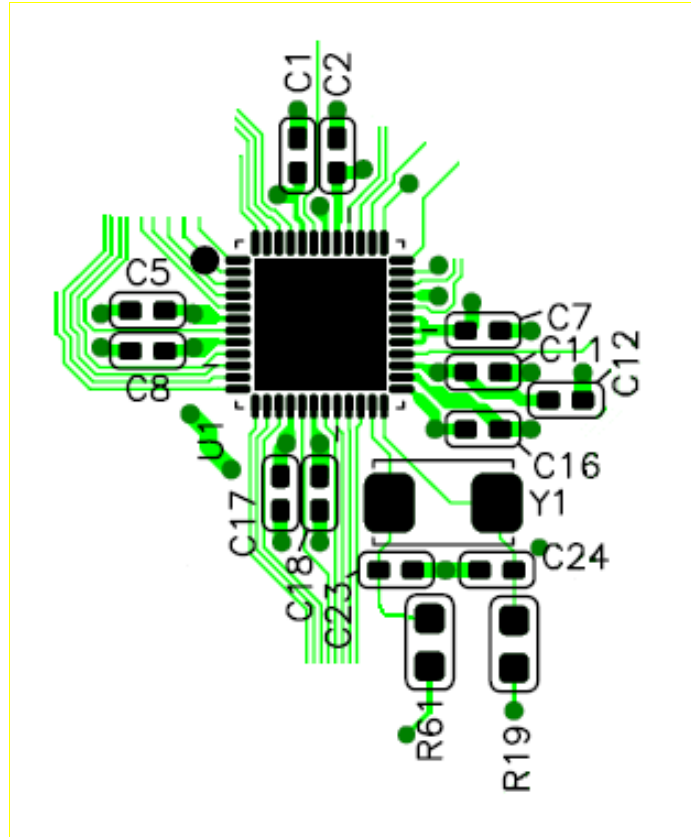
Proper decoupling is required to ensure proper operation of an FT 6000 Smart Transceiver or Neuron 6000 Processor. When you connect  $V_{DD}$  decoupling capacitors to Series 6000 chips, make the leads as short as possible. All  $V_{DD}$  pins must be tied to +3.3 V, and all GND pins to ground. Keep the crystal circuit close to the Series 6000 chip and isolated from communications lines.

Bypass capacitors should be 0.1  $\mu\text{F}$  or 0.33  $\mu\text{F}$  ceramic or dipped-mica capacitors, and should be placed as close to  $V_{DD33}$  pins as possible.  $V_{DD33}$  and GND loops should be avoided. Recommended configurations are:

- VDD3V3 pins: 8, 18, 29, 30, 31, 41
- VDD1V8 pins: 6, 16, 27, 44

**Recommendation:** Add an additional 1.0  $\mu\text{F}$  (6.3 V, 10%, X7R) capacitor to pin 27 to provide extra protection and stability for the Series 6000 chip's internal voltage regulator.

Figure 58 shows suggested bypass capacitor placement and crystal circuit trace outlines. See *Pin Connections* for additional information about placing these capacitors.



**Figure 58.** Minimum Recommended Capacitor Placement

The reference designators shown in the figure and the table are included as examples only.

**Table 44.** Parts Shown in the Figure

Reference	Part
C1	0.1 $\mu\text{F}$ for pin 44 VDD1V8
C2	0.1 $\mu\text{F}$ for pin 41 VDD3V3 and pin 42 VDD3V3
C5	0.1 $\mu\text{F}$ for pin 6 VDD1V8
C7	0.1 $\mu\text{F}$ for pin 31 AVDD3V3, pin 30 VDD3V3, and pin 29 VIN3V3
C8	0.1 $\mu\text{F}$ for pin 8 VDD3V3
C11	0.1 $\mu\text{F}$ for pin 27 VOUT1V8

Reference	Part
C12	1.0 $\mu$ F for pin 27 <b>VOUT1V8</b>
C16	0.01 $\mu$ F across pins 25 and 26 ( <b>VDDPLL</b> and <b>GNDPLL</b> )
C17	0.1 $\mu$ F for pin 16 <b>VDD1V8</b>
C18	0.1 $\mu$ F for pin 18 <b>VDD3V3</b>
C23	30 pF for pin 23 <b>XIN</b>
C24	30 pF for pin 24 <b>XOUT</b>
R19	200 $\Omega$ for pin 24 <b>XOUT</b>
R61	1 M $\Omega$ across pins 23 and 24 ( <b>XIN</b> and <b>XOUT</b> )
Y1	External 10 MHz crystal

**Key Layout Rules:**

1. If possible, use 4-layer boards (or boards with more than four layers). Additional layers simplify the layout, and reduce noise-related and grounding problems.
2. For 2-layer boards, the four bypass capacitors must be close to the Series 6000 chip.  $V_{DD}$  and ground must use large traces to reduce inductance and noise.
3. On 2-layer boards, avoid running high-frequency digital signal traces under the crystal circuit or the communications port, on opposite sides of the board.
4. Ensure that power supply and ground traces are large enough to handle the peak surge switching currents. Otherwise, there can be power supply dips on the  $V_{DD}$  pins, which could cause errors in the checksum calculation, resulting in the Series 6000 chip's resetting.



# E

## Example Schematic

This appendix provides an example schematic for an FT 6000 Smart Transceiver, with associated non-volatile memory, communications transformer, and network connections.

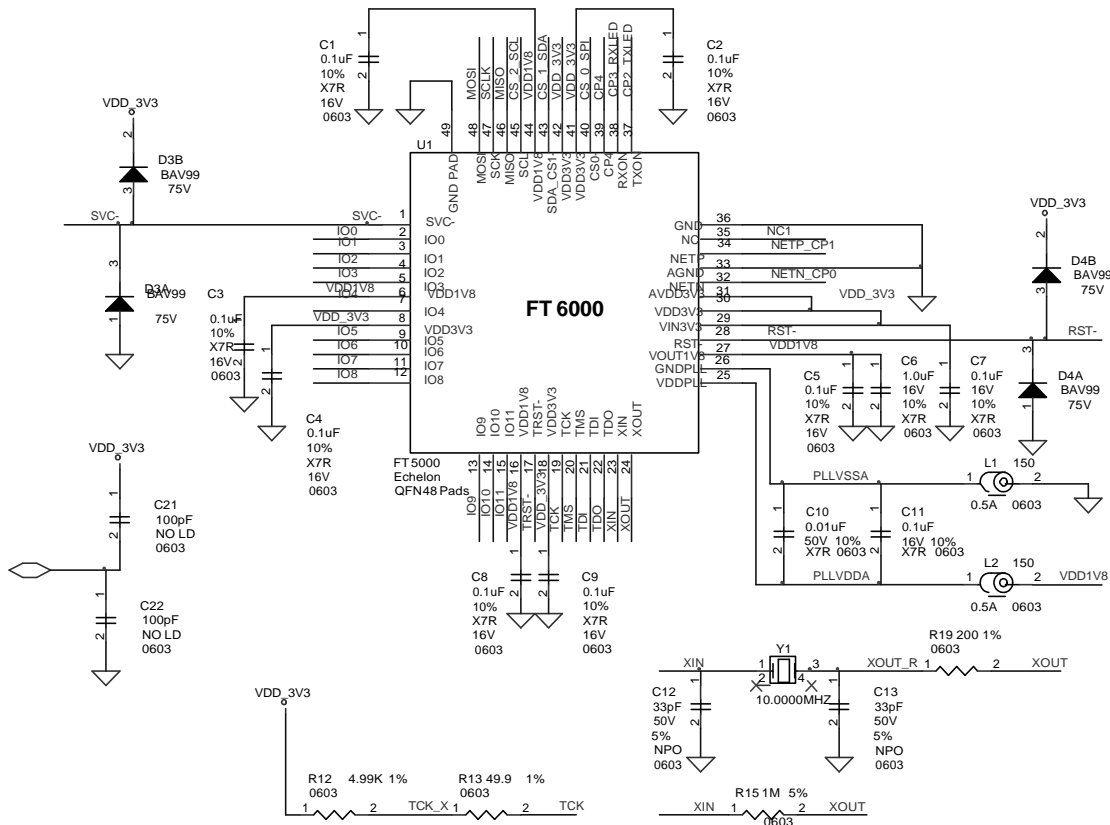
## Example Schematic

This appendix provides an example schematic for an FT 6000 Smart Transceiver. The example schematics are based on the FT 6000 Evaluation Board that is included with the FT 6000 Evaluation Kit. The example schematic incorporates the design requirements that are described in the following sections:

- *On-Chip Memory*
- *Memory Map*
- *External Serial Memory Interface*
- *Pin Connections*
- *Connection for an FT 6000 Smart Transceiver*
- *Clock Requirements*
- *Transformer Electrical Connections*

## Basic Electrical Connections

Figure 60 shows the basic electrical connections for the FT 6000 Smart Transceiver.

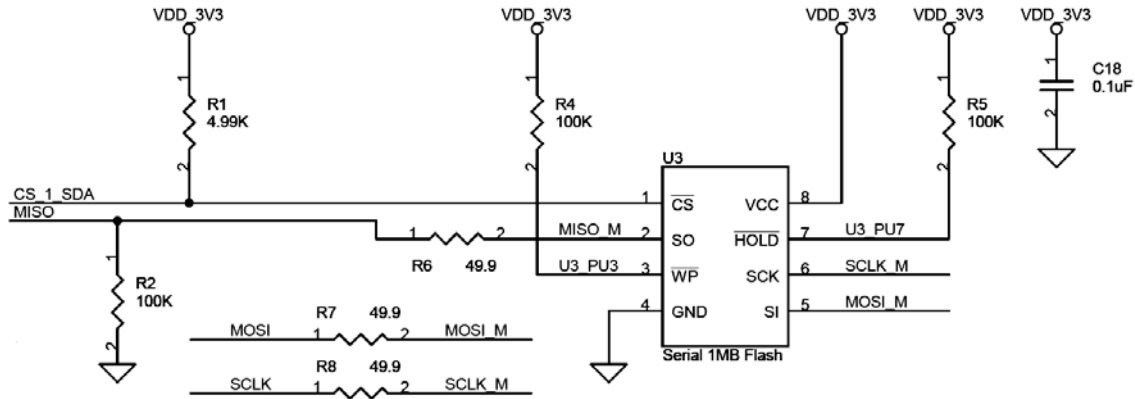


**Figure 60.** Basic Electrical Connections



## Memory Interface Connections

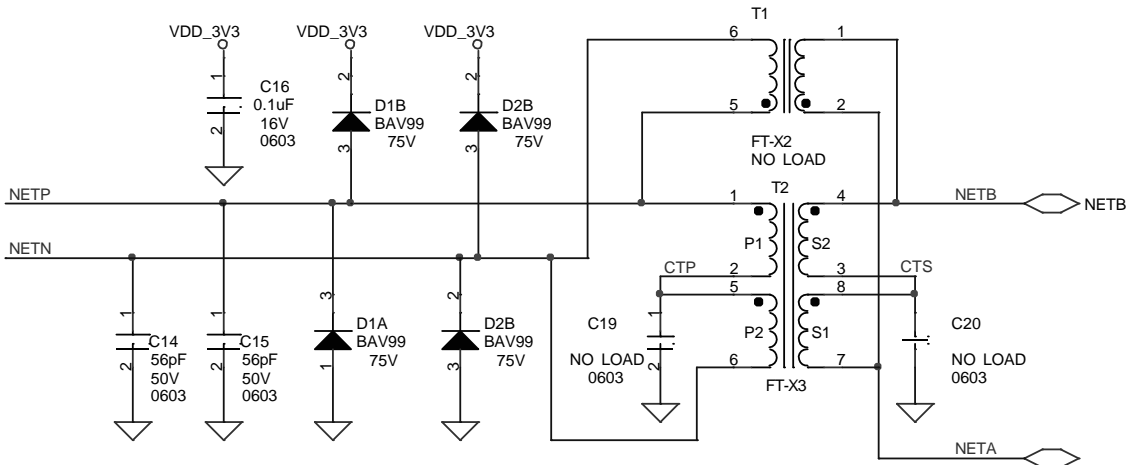
Figure 61 shows the connections for the serial flash memory device.



**Figure 61.** Memory Interface Connections

## Transformer Connections

Figure 62 shows the connections for the communications transformer. The figure shows connections for both the FT-X2 Communication Transformer and the FT-X3 Communications Transformer. Your PCBA would include only an FT-X2 or an FT-X3. The capacitors C19 and C20 are generally not needed to pass EMC testing, and can be omitted.



**Figure 62.** Transformer Connections

## I/O and Network Connections

Figure 63 shows the basic I/O connections and the network connections. The figure does not show external I/O devices, and thus does not include pull-up or pull-down resistors for the IO0..IO11 signals.

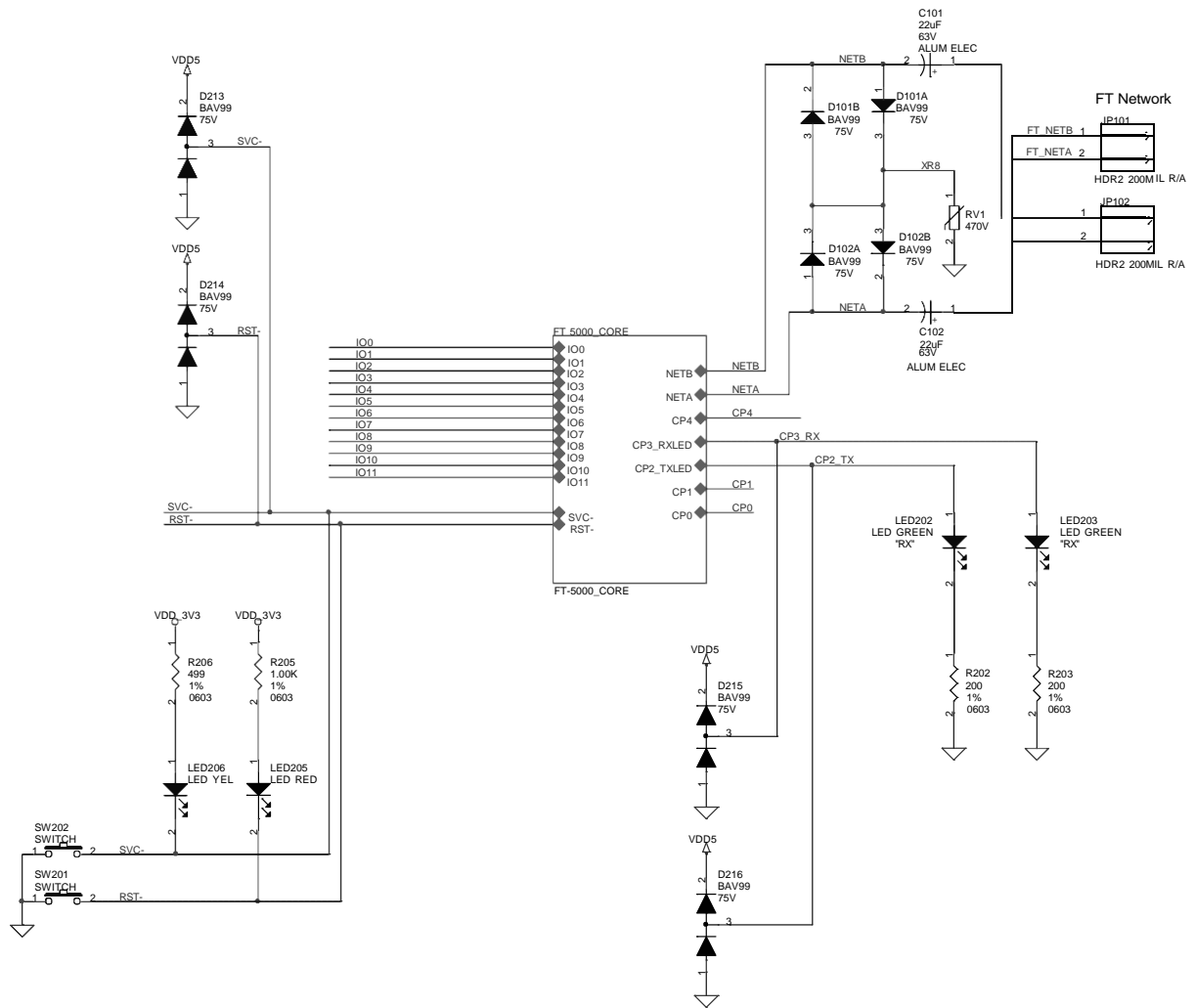


Figure 63. I/O and Network Connections

## BOM for Example Schematic

Table 45 shows a partial bill of materials (BOM) for the example schematic shown in this appendix.

Table 45. Example BOM for Example Schematic

Reference Designator	Value
C10	0.01 $\mu$ F
C12, C13	33 pF
C14, C15	56 pF
C19, C20, C21, C22	100 pF
C1, C2, C3, C4, C5, C7, C8, C9, C11, C16, C17, C18	0.1 $\mu$ F

Reference Designator	Value
C6	1.0 $\mu$ F
C101, C102	22 $\mu$ F
D1, D2, D3, D4, D101, D102, D213, D214, D215, D216	BAV99
L1, L2	150 $\Omega$
R6, R7, R8, R13	49.9 $\Omega$
R18, R202, R203	200 $\Omega$
R206	499 $\Omega$
R205	1.00 k $\Omega$
R1, R9, R10, R12	4.99 k $\Omega$
R2, R3, R4, R5	100 k $\Omega$
R15	1 M $\Omega$
RV1	470 V
T2	Echelon FT-X3
T1	Echelon FT-X2 (not needed if FT-X3 is present)
U1	Echelon FT 6000 Smart Transceiver
U3	Winbond W25Q80BV serial flash
Y1	10.0000 MHz

# F

## Vendor Contact Information

This appendix lists contact information for many of the product vendors mentioned in this manual.

---

## Vendor Information

This appendix lists contact information for many of the product vendors mentioned in this manual. For most of the parts listed in this manual, Echelon does not require that you use these vendors, but recommends products from the vendors listed.

---

### *Abracon Corporation*

[www.abracon.com](http://www.abracon.com)

---

### *Atmel Corporation*

[www.atmel.com](http://www.atmel.com)

---

### *Belden Inc.*

[www.belden.com](http://www.belden.com)

---

### *BPM Microsystems*

[www.bpmmicro.com](http://www.bpmmicro.com)

---

### *Citel Inc.*

[www.citelprotection.com](http://www.citelprotection.com)

---

### *CommScope Inc.*

[www.commscope.com](http://www.commscope.com)

---

### *Emulation Technology Inc.*

[www.emulation.com](http://www.emulation.com)

---

### *Fairchild Semiconductor Inc.*

[www.fairchildsemi.com](http://www.fairchildsemi.com)

---

### *HiLo System Research Company Ltd.*

[www.hilosystems.com.tw](http://www.hilosystems.com.tw)

---

*Laird Technologies PLC*

[www.lairdtech.com](http://www.lairdtech.com)

---

*Littelfuse Inc.*

[www.littelfuse.com](http://www.littelfuse.com)

---

*Numonyx BV*

[www.numonyx.com](http://www.numonyx.com)

---

*NXP Semiconductors BV*

[www.nxp.com](http://www.nxp.com)

---

*ON Semiconductor*

[www.onsemi.com](http://www.onsemi.com)

---

*Panasonic Corp.*

[panasonic.co.jp/index3.html](http://panasonic.co.jp/index3.html)

[panasonic.com](http://panasonic.com)

---

*Plastronics Socket Company Inc.*

[www.plastronicsusa.com](http://www.plastronicsusa.com)

---

*Sankosha Corp.*

[www.sankosha-usa.com](http://www.sankosha-usa.com)

---

*Silicon Storage Technology Inc.*

[www.sst.com](http://www.sst.com)

---

*Taiyo Yuden Company Ltd.*

[www.t-yuden.com](http://www.t-yuden.com) or [www.yuden.co.jp/e/index.html](http://www.yuden.co.jp/e/index.html)

---

*TDK Corp.*

[www.tdk.com](http://www.tdk.com)

---

*Total Phase Inc.*

[www.totalphase.com](http://www.totalphase.com)

---

*Vishay Intertechnology Inc.*

[www.vishay.com](http://www.vishay.com)

