

Target Board for RX23W module Schematic
 (Product No: RTK5RX23W0C01000BJ)

PAGE	DESCRIPTION
1	Index
2	MAIN
3	USER BLOCK
4	Emulator Circuit

Note:
 C, EC : Capacitor
 D : Diode
 R : Fixed Resistor
 U, EU : Integrated Circuit
 X : Crystal, Oscillator
 SW, RES : Switch
 LED : Light Emitting Diode
 J, CN : Connector
 JP : Jumper
 L : Inductor
 N.C. : Not connected
 SS : Short-pad Short-type(Default : Short)
 SO : Short-pad Open-type(Default : Open)

* "DNF" marking means that component
 is not fitted by default.

RENESAS		Renesas Electronics Corporation	
Title Target Board for RX23W module Schematic [Index]			
Size A4	Document Number R20UT4889EJ0100		Rev 1.00
Date: January 15, 2021	Sheet		1 of 4

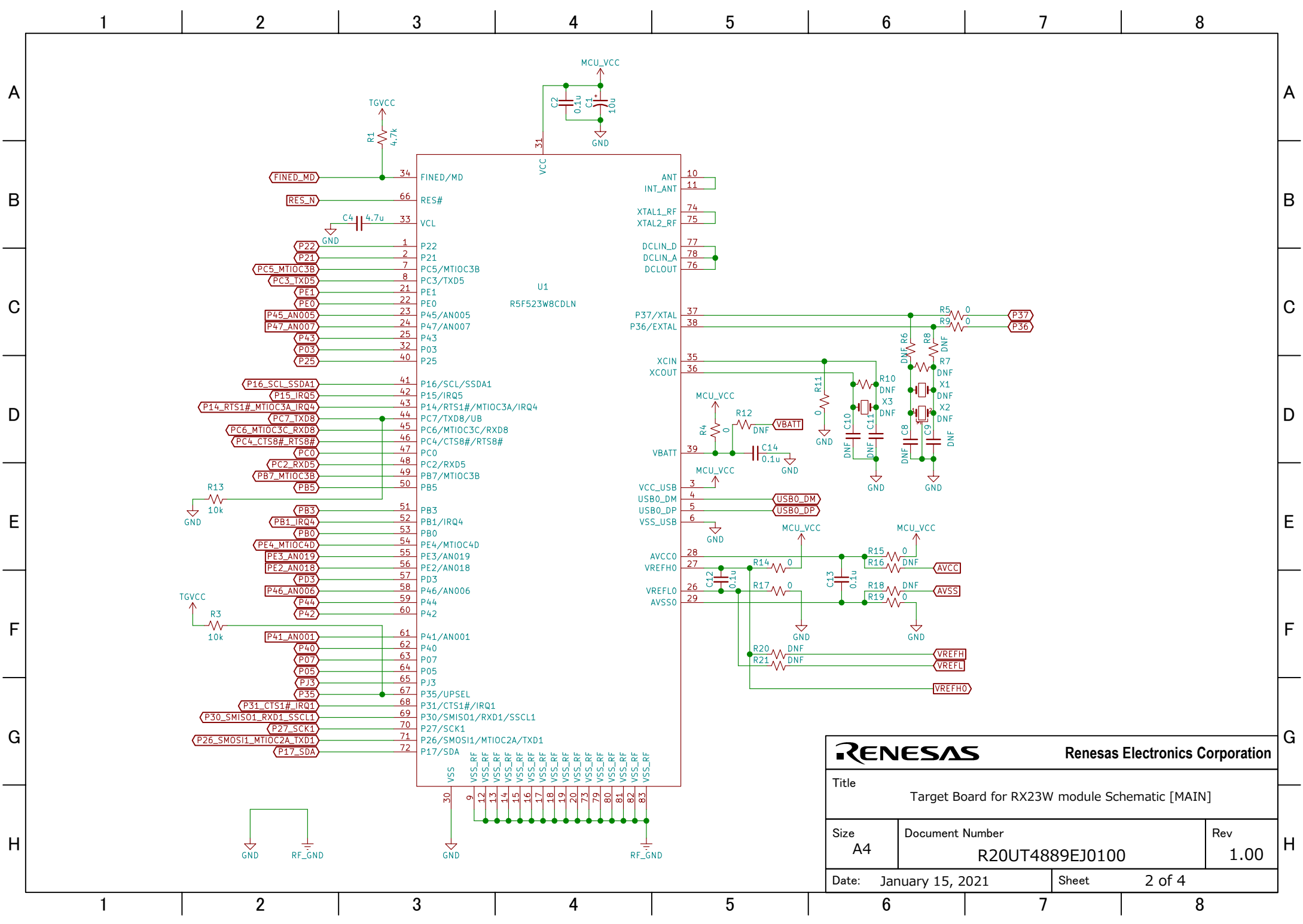

RENESAS		Renesas Electronics Corporation	
Title Target Board for RX23W module Schematic [MAIN]			
Size A4	Document Number R20UT4889EJ0100		Rev 1.00
Date: January 15, 2021		Sheet	2 of 4

PMOD

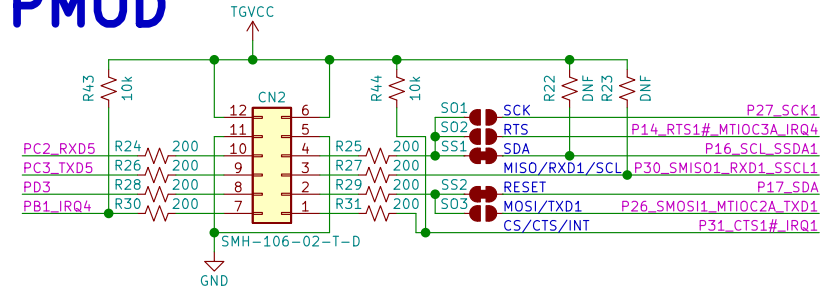

Arduino I/F

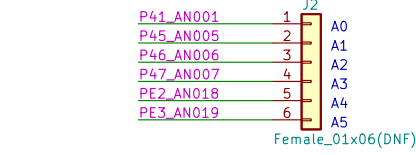

MCU HEADER

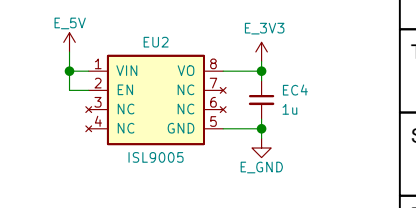
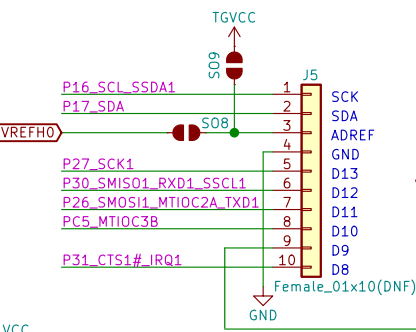
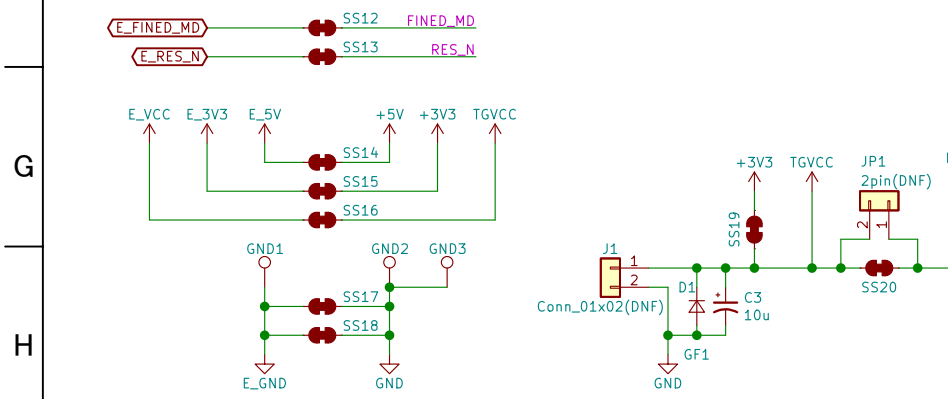
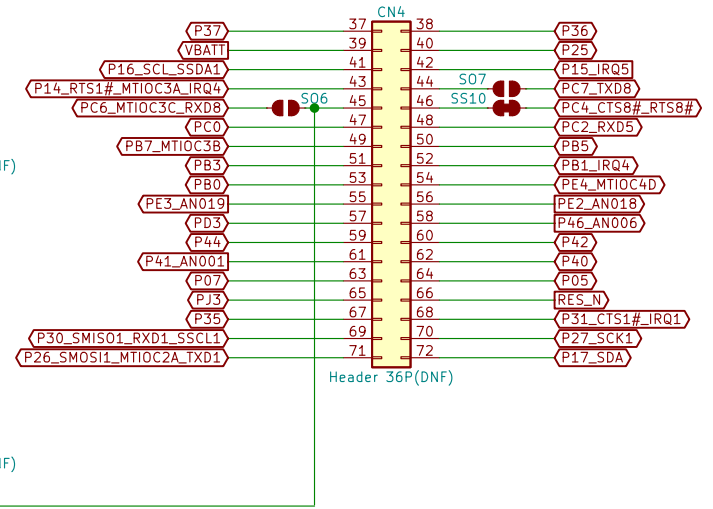
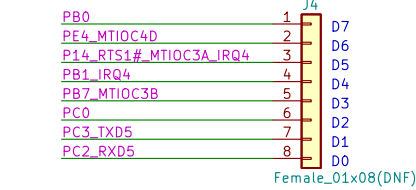
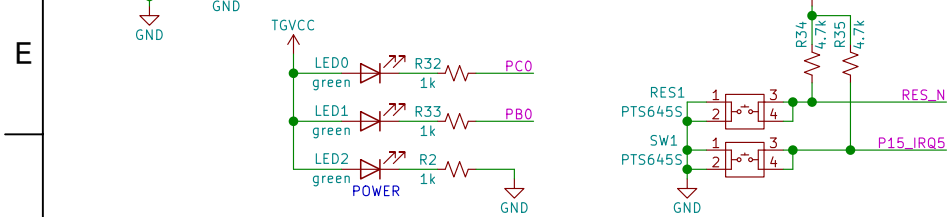
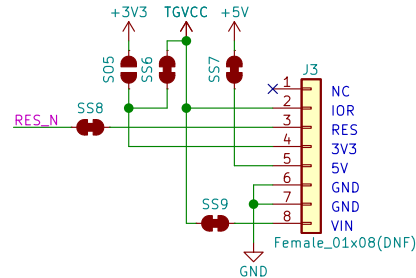
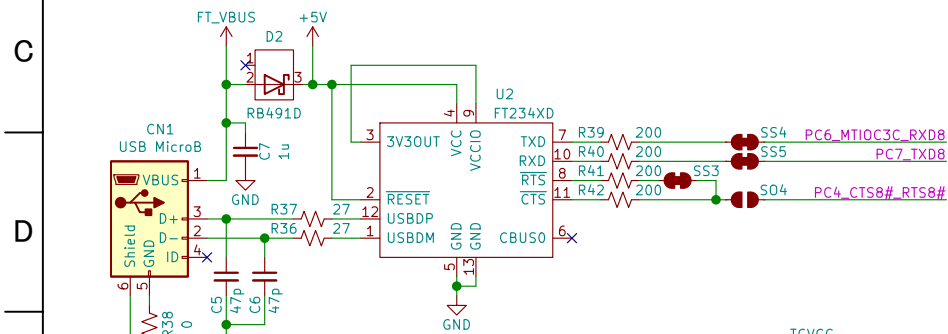
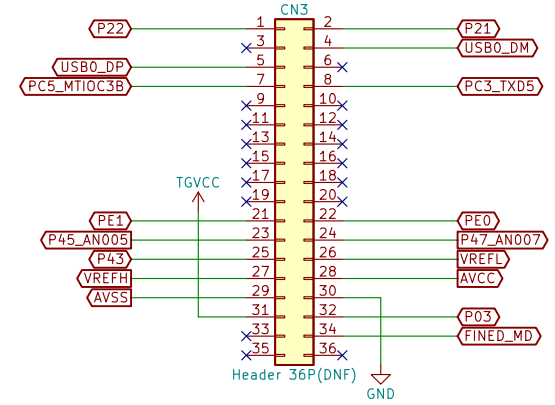

RENESAS		Renesas Electronics Corporation	
Title Target Board for RX23W module Schematic [USER BLOCK]			
Size A4	Document Number R20UT4889EJ0100	Rev 1.00	
Date: January 15, 2021	Sheet 3 of 4		

1 2 3 4 5 6 7 8

A

A

B

B

C

C

D

D

E

E

F

F

G

G

H

H

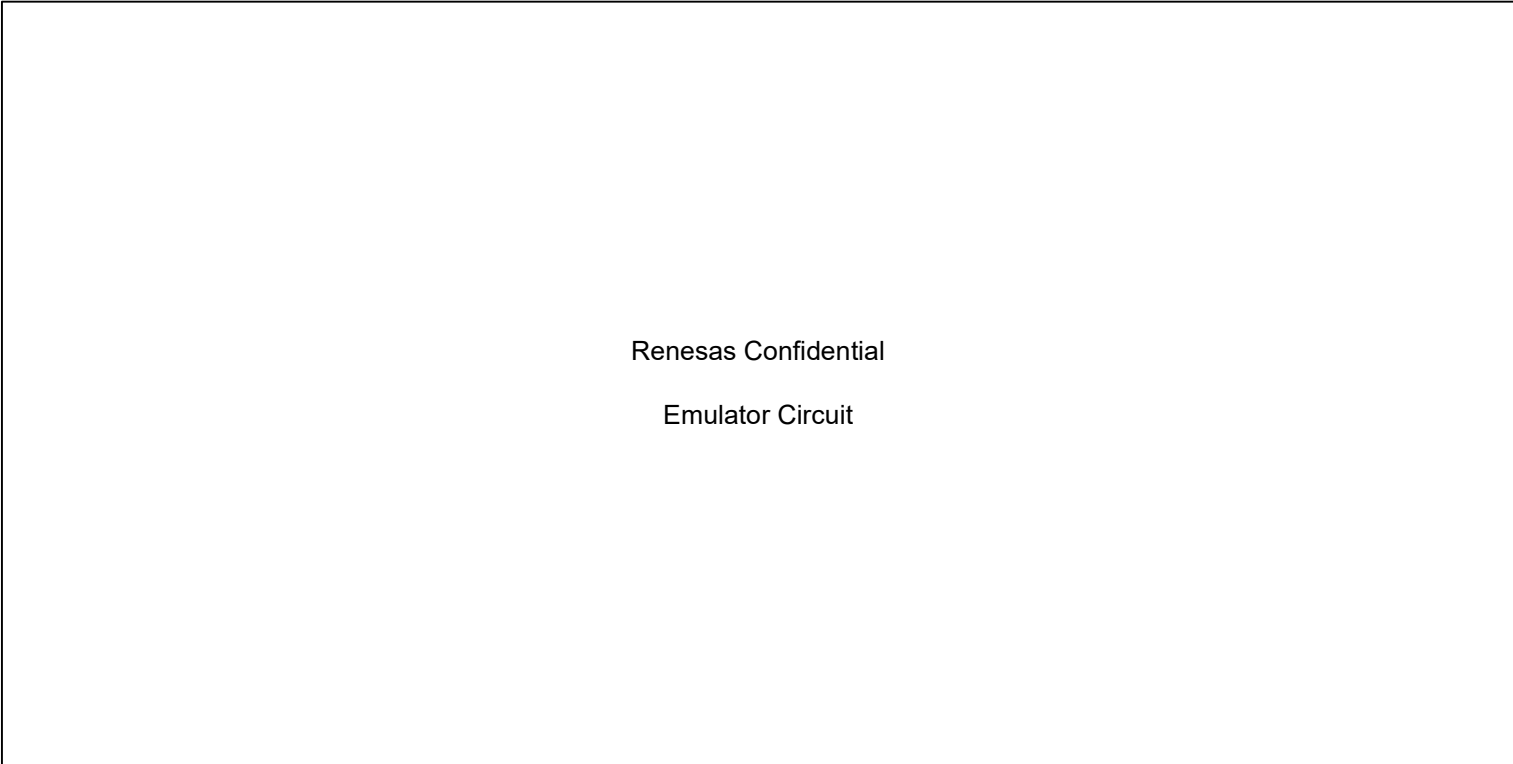

Renesas Confidential
Emulator Circuit

RENESAS Renesas Electronics Corporation

Title Target Board for RX23W module Schematic [Emulator Circuit]

Size A4	Document Number R20UT4889EJ0100	Rev 1.00
------------	------------------------------------	-------------

Date: January 15, 2021	Sheet 4 of 4
------------------------	--------------

1 2 3 4 5 6 7 8