

# RA6T1 Group

Motor Control Evaluation System for RA Family  
- RA6T1 Group  
Quick Start Guide

Renesas RA Family  
RA6 Series

All information contained in these materials, including products and product specifications, represents information on the product at the time of publication and is subject to change by Renesas Electronics Corp. without notice. Please review the latest information published by Renesas Electronics Corp. through various means, including the Renesas Electronics Corp. website (<http://www.renesas.com>).

## Notice

1. Descriptions of circuits, software and other related information in this document are provided only to illustrate the operation of semiconductor products and application examples. You are fully responsible for the incorporation or any other use of the circuits, software, and information in the design of your product or system. Renesas Electronics disclaims any and all liability for any losses and damages incurred by you or third parties arising from the use of these circuits, software, or information.
2. Renesas Electronics hereby expressly disclaims any warranties against and liability for infringement or any other claims involving patents, copyrights, or other intellectual property rights of third parties, by or arising from the use of Renesas Electronics products or technical information described in this document, including but not limited to, the product data, drawings, charts, programs, algorithms, and application examples.
3. No license, express, implied or otherwise, is granted hereby under any patents, copyrights or other intellectual property rights of Renesas Electronics or others.
4. You shall not alter, modify, copy, or reverse engineer any Renesas Electronics product, whether in whole or in part. Renesas Electronics disclaims any and all liability for any losses or damages incurred by you or third parties arising from such alteration, modification, copying or reverse engineering.
5. Renesas Electronics products are classified according to the following two quality grades: "Standard" and "High Quality". The intended applications for each Renesas Electronics product depends on the product's quality grade, as indicated below.

"Standard": Computers; office equipment; communications equipment; test and measurement equipment; audio and visual equipment; home electronic appliances; machine tools; personal electronic equipment; industrial robots; etc.

"High Quality": Transportation equipment (automobiles, trains, ships, etc.); traffic control (traffic lights); large-scale communication equipment; key financial terminal systems; safety control equipment; etc.

Unless expressly designated as a high reliability product or a product for harsh environments in a Renesas Electronics data sheet or other Renesas Electronics document, Renesas Electronics products are not intended or authorized for use in products or systems that may pose a direct threat to human life or bodily injury (artificial life support devices or systems; surgical implantations; etc.), or may cause serious property damage (space system; undersea repeaters; nuclear power control systems; aircraft control systems; key plant systems; military equipment; etc.). Renesas Electronics disclaims any and all liability for any damages or losses incurred by you or any third parties arising from the use of any Renesas Electronics product that is inconsistent with any Renesas Electronics data sheet, user's manual or other Renesas Electronics document.

6. When using Renesas Electronics products, refer to the latest product information (data sheets, user's manuals, application notes, "General Notes for Handling and Using Semiconductor Devices" in the reliability handbook, etc.), and ensure that usage conditions are within the ranges specified by Renesas Electronics with respect to maximum ratings, operating power supply voltage range, heat dissipation characteristics, installation, etc. Renesas Electronics disclaims any and all liability for any malfunctions, failure or accident arising out of the use of Renesas Electronics products outside of such specified ranges.
7. Although Renesas Electronics endeavors to improve the quality and reliability of Renesas Electronics products, semiconductor products have specific characteristics, such as the occurrence of failure at a certain rate and malfunctions under certain use conditions. Unless designated as a high reliability product or a product for harsh environments in a Renesas Electronics data sheet or other Renesas Electronics document, Renesas Electronics products are not subject to radiation resistance design. You are responsible for implementing safety measures to guard against the possibility of bodily injury, injury or damage caused by fire, and/or danger to the public in the event of a failure or malfunction of Renesas Electronics products, such as safety design for hardware and software, including but not limited to redundancy, fire control and malfunction prevention, appropriate treatment for aging degradation or any other appropriate measures. Because the evaluation of microcomputer software alone is very difficult and impractical, you are responsible for evaluating the safety of the final products or systems manufactured by you.
8. Please contact a Renesas Electronics sales office for details as to environmental matters such as the environmental compatibility of each Renesas Electronics product. You are responsible for carefully and sufficiently investigating applicable laws and regulations that regulate the inclusion or use of controlled substances, including without limitation, the EU RoHS Directive, and using Renesas Electronics products in compliance with all these applicable laws and regulations. Renesas Electronics disclaims any and all liability for damages or losses occurring as a result of your noncompliance with applicable laws and regulations.
9. Renesas Electronics products and technologies shall not be used for or incorporated into any products or systems whose manufacture, use, or sale is prohibited under any applicable domestic or foreign laws or regulations. You shall comply with any applicable export control laws and regulations promulgated and administered by the governments of any countries asserting jurisdiction over the parties or transactions.
10. It is the responsibility of the buyer or distributor of Renesas Electronics products, or any other party who distributes, disposes of, or otherwise sells or transfers the product to a third party, to notify such third party in advance of the contents and conditions set forth in this document.
11. This document shall not be reprinted, reproduced or duplicated in any form, in whole or in part, without prior written consent of Renesas Electronics.
12. Please contact a Renesas Electronics sales office if you have any questions regarding the information contained in this document or Renesas Electronics products.

(Note1) "Renesas Electronics" as used in this document means Renesas Electronics Corporation and also includes its directly or indirectly controlled subsidiaries.

(Note2) "Renesas Electronics product(s)" means any product developed or manufactured by or for Renesas Electronics.

(Rev.4.0-1 November 2017)

## Corporate Headquarters

TOYOSU FORESIA, 3-2-24 Toyosu,  
Koto-ku, Tokyo 135-0061, Japan  
[www.renesas.com](http://www.renesas.com)

## Trademarks

Renesas and the Renesas logo are trademarks of Renesas Electronics Corporation. All trademarks and registered trademarks are the property of their respective owners.

## Contact information

For further information on a product, technology, the most up-to-date version of a document, or your nearest sales office, please visit:  
[www.renesas.com/contact/](http://www.renesas.com/contact/).

# General Precautions in the Handling of Microprocessing Unit and Microcontroller Unit Products

The following usage notes are applicable to all Microprocessing unit and Microcontroller unit products from Renesas. For detailed usage notes on the products covered by this document, refer to the relevant sections of the document as well as any technical updates that have been issued for the products.

## 1. Precaution against Electrostatic Discharge (ESD)

A strong electrical field, when exposed to a CMOS device, can cause destruction of the gate oxide and ultimately degrade the device operation. Steps must be taken to stop the generation of static electricity as much as possible, and quickly dissipate it when it occurs. Environmental control must be adequate. When it is dry, a humidifier should be used. This is recommended to avoid using insulators that can easily build up static electricity. Semiconductor devices must be stored and transported in an anti-static container, static shielding bag or conductive material. All test and measurement tools including work benches and floors must be grounded. The operator must also be grounded using a wrist strap. Semiconductor devices must not be touched with bare hands. Similar precautions must be taken for printed circuit boards with mounted semiconductor devices.

## 2. Processing at power-on

The state of the product is undefined at the time when power is supplied. The states of internal circuits in the LSI are indeterminate and the states of register settings and pins are undefined at the time when power is supplied. In a finished product where the reset signal is applied to the external reset pin, the states of pins are not guaranteed from the time when power is supplied until the reset process is completed. In a similar way, the states of pins in a product that is reset by an on-chip power-on reset function are not guaranteed from the time when power is supplied until the power reaches the level at which resetting is specified.

## 3. Input of signal during power-off state

Do not input signals or an I/O pull-up power supply while the device is powered off. The current injection that results from input of such a signal or I/O pull-up power supply may cause malfunction and the abnormal current that passes in the device at this time may cause degradation of internal elements. Follow the guideline for input signal during power-off state as described in your product documentation.

## 4. Handling of unused pins

Handle unused pins in accordance with the directions given under handling of unused pins in the manual. The input pins of CMOS products are generally in the high-impedance state. In operation with an unused pin in the open-circuit state, extra electromagnetic noise is induced in the vicinity of the LSI, an associated shoot-through current flows internally, and malfunctions occur due to the false recognition of the pin state as an input signal become possible.

## 5. Clock signals

After applying a reset, only release the reset line after the operating clock signal becomes stable. When switching the clock signal during program execution, wait until the target clock signal is stabilized. When the clock signal is generated with an external resonator or from an external oscillator during a reset, ensure that the reset line is only released after full stabilization of the clock signal. Additionally, when switching to a clock signal produced with an external resonator or by an external oscillator while program execution is in progress, wait until the target clock signal is stable.

## 6. Voltage application waveform at input pin

Waveform distortion due to input noise or a reflected wave may cause malfunction. If the input of the CMOS device stays in the area between  $V_{IL}$  (Max.) and  $V_{IH}$  (Min.) due to noise, for example, the device may malfunction. Take care to prevent chattering noise from entering the device when the input level is fixed, and also in the transition period when the input level passes through the area between  $V_{IL}$  (Max.) and  $V_{IH}$  (Min.).

## 7. Prohibition of access to reserved addresses

Access to reserved addresses is prohibited. The reserved addresses are provided for possible future expansion of functions. Do not access these addresses as the correct operation of the LSI is not guaranteed.

## 8. Differences between products

Before changing from one product to another, for example to a product with a different part number, confirm that the change will not lead to problems. The characteristics of a microprocessing unit or microcontroller unit products in the same group but having a different part number might differ in terms of internal memory capacity, layout pattern, and other factors, which can affect the ranges of electrical characteristics, such as characteristic values, operating margins, immunity to noise, and amount of radiated noise. When changing to a product with a different part number, implement a system-evaluation test for the given product.

Renesas RA Family

# Motor Control Evaluation System for RA Family - RA6T1 Group Quick Start Guide

## Contents

1. Introduction.....	5
1.1 Presupposition and precautions of this document .....	5
2. Product Contents.....	6
3. Quick Start Sample Project Overview .....	7
3.1 Quick start sample project flow .....	7
4. Execute the Quick Start Sample Project .....	8
4.1 Connect the board and supply power .....	9
4.1.1 Jumper pin setting .....	9
4.1.2 Connect the motor and the board .....	10
4.1.3 Connect the stabilized power supply and the cables .....	10
4.1.4 Turn on power supply.....	11
4.2 Execute the quick start sample project .....	12
5. Customize the Quick Start Sample Project .....	13
5.1 Connection method .....	13
6. Others.....	15
7. Website and Support.....	16

**Figure table of contents**

Figure 2-1 Product contents ..... 6  
Figure 3-1 Quick start sample project flow ..... 7  
Figure 4-1 Jumper pin setting ..... 9  
Figure 4-2 Connect cables ..... 10  
Figure 4-3 Connect the stabilized power supply ..... 11  
Figure 5-1 Connect cables ..... 14

**Table of contents**

Table 4-1 Jumper pin setting ..... 9

## 1. Introduction

This Quick Start Guide (QSG) describes the followings.

- Overview of the Quick Start Sample Project which has already been programmed into the RA6T1 CPU Card.
- Steps to execute the Quick Start Sample Project.

### 1.1 Presupposition and precautions of this document

1. Experience of using tools: This document assumes that the user has used terminal emulation program of Integrated Development Environment (IDE) such as e2 studio before.
2. Knowledge about the development subject: This document assumes that the user has a basic knowledge to modify the sample project regarding MCU and embedded system.
3. Before using this product, wear an antistatic wrist strap. If you touch this product with static charge on your body, a device failure may occur or operation may become unstable
4. To use this product prepare the following items, too.
  - Stabilized power supply : Output voltage of DC24 V or higher, the upper limit of the output current can be set at 1A
  - Power supply cable (x2) : Cables which enable to apply the current of 1A or higher.  
(To connect the stabilized power supply and the inverter board)
5. All screen shots provided in this document is for reference. Actual screen displays may differ depending on the software and development tool version which you use.

## 2. Product Contents

This kit consists of the following parts.

1. Inverter Board (RTK0EM0000B10020BJ)
2. RA6T1 CPU Card (RTK0EMA170C00000BJ)
3. Brushless DC Motor (TG-55L-KA 24V)
4. Motor Cable
5. Communication Cable
6. USB Cable
7. Ferrite Core

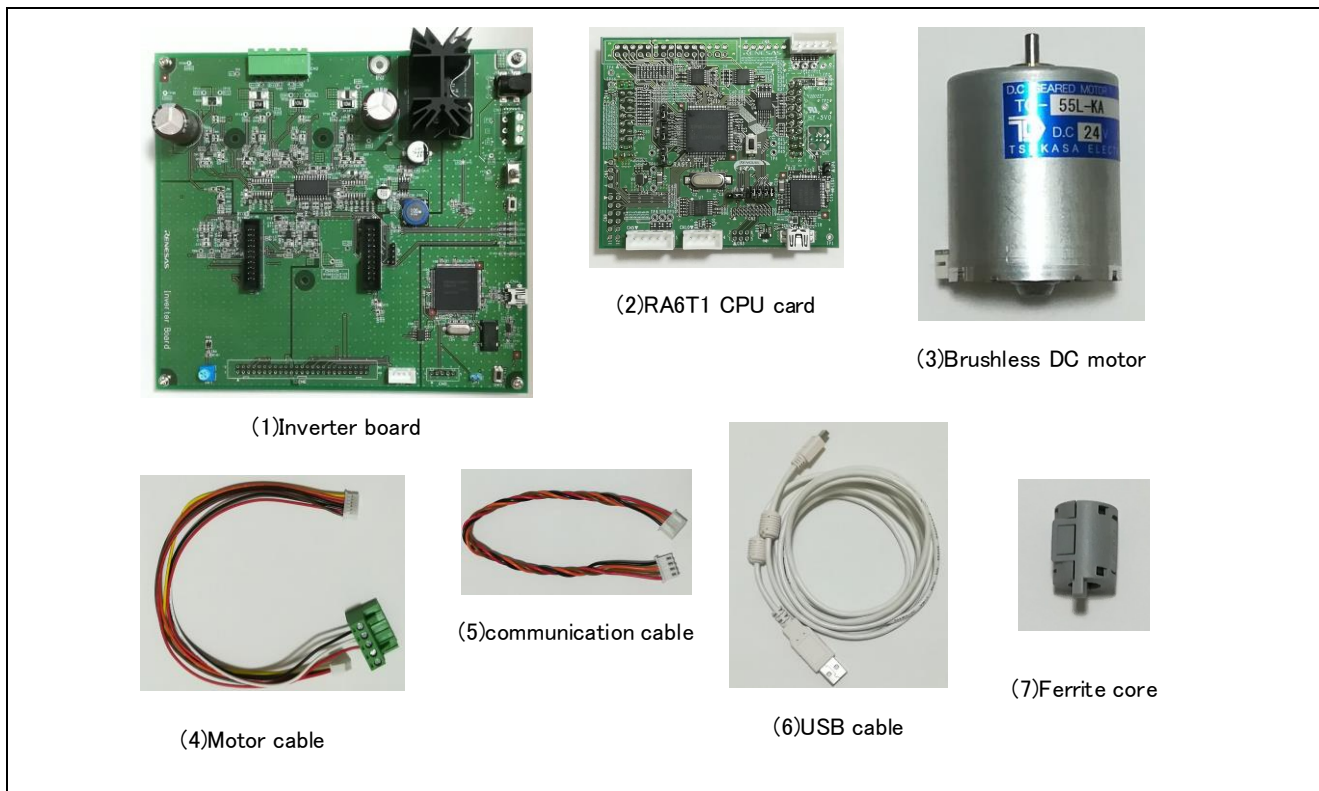

Figure 2-1 Product contents

### 3. Quick Start Sample Project Overview

In the Quick Start Sample Project, users can start/stop the rotation and change the rotation speed of the supplied permanent magnet synchronous motor by TSUKASA ELECTRIC CO., LTD, "TG-55L-KA" (hereinafter called "Motor") with the toggle switch and the volume on the inverter board.

#### 3.1 Quick start sample project flow

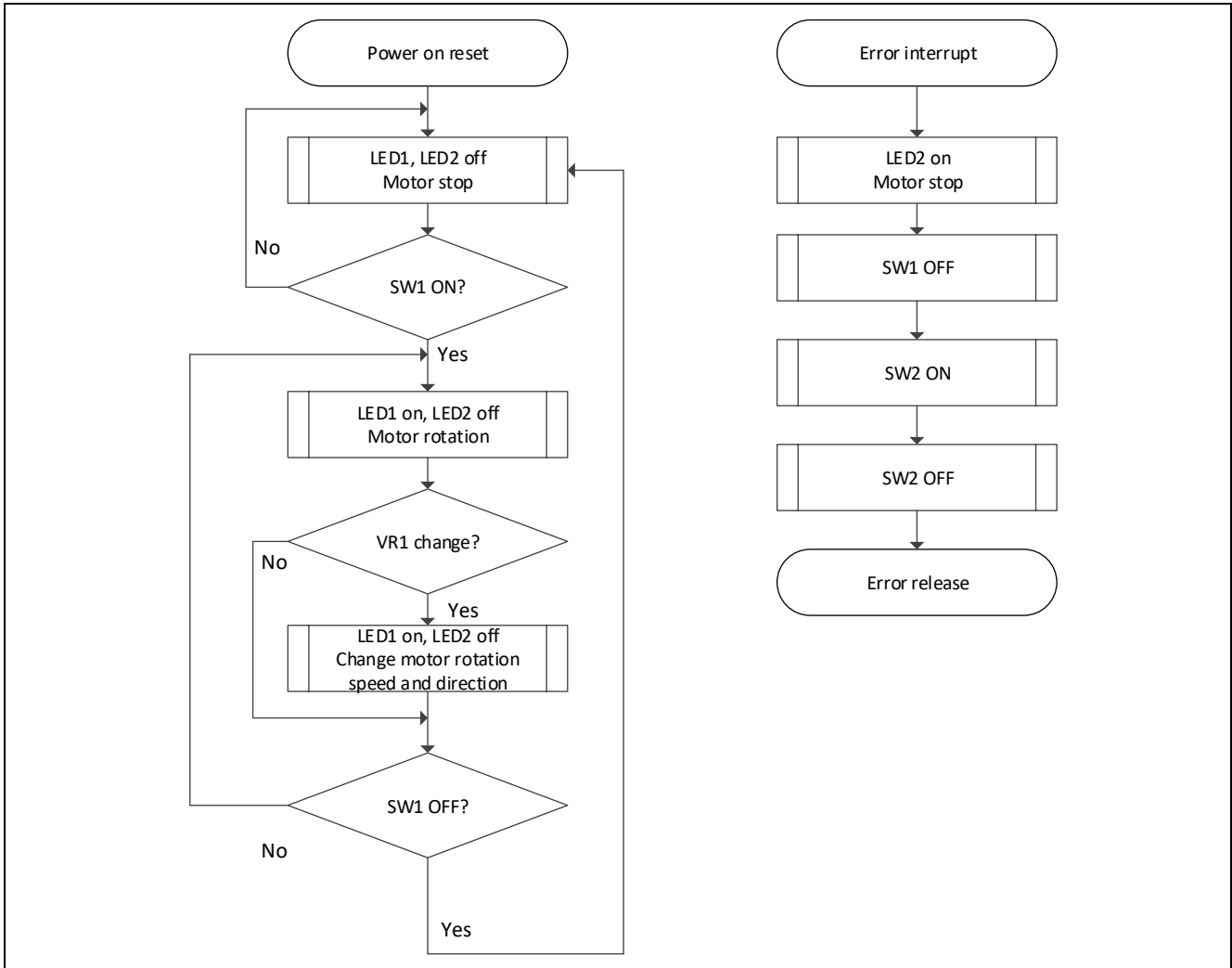

Figure 3-1 Quick start sample project flow



## 4. Execute the Quick Start Sample Project

This chapter describes the requirements and steps to turn on the power supply of the Motor Control Evaluation System for RA Family - RA6T1 Group and execute the Quick Start Sample Project. The software to control sensorless vector is written in RA6T1.

### Hardware Requirement :

- Inverter Board
- RA6T1 CPU Card
- Permanent Magnet Synchronous Motor : TG-55L-KA
- Motor Cable
- Ferrite Core
- Stabilized Power Supply : Output voltage of DC24V or higher, the upper limit of the output current can be set at 1A
- Power Supply Cable (x2) : Cables which enable to apply the current of 1A or higher.  
(To connect the stabilized power supply and the inverter board)

### Software Requirement :

- None

## 4.1 Connect the board and supply power

### 4.1.1 Jumper pin setting

Check that the jumper pins (JP1~JP6) are set as shown in the below table.

Table 4-1 Jumper pin setting

Jumper Pin	Setting
JP1	2-3pin short
JP2	2-3pin short
JP3	1-2pin short
JP4	1-2pin open
JP5	1-2pin, 3-4pin, 5-6pin, 7-8pin short
JP6	1-2pin short

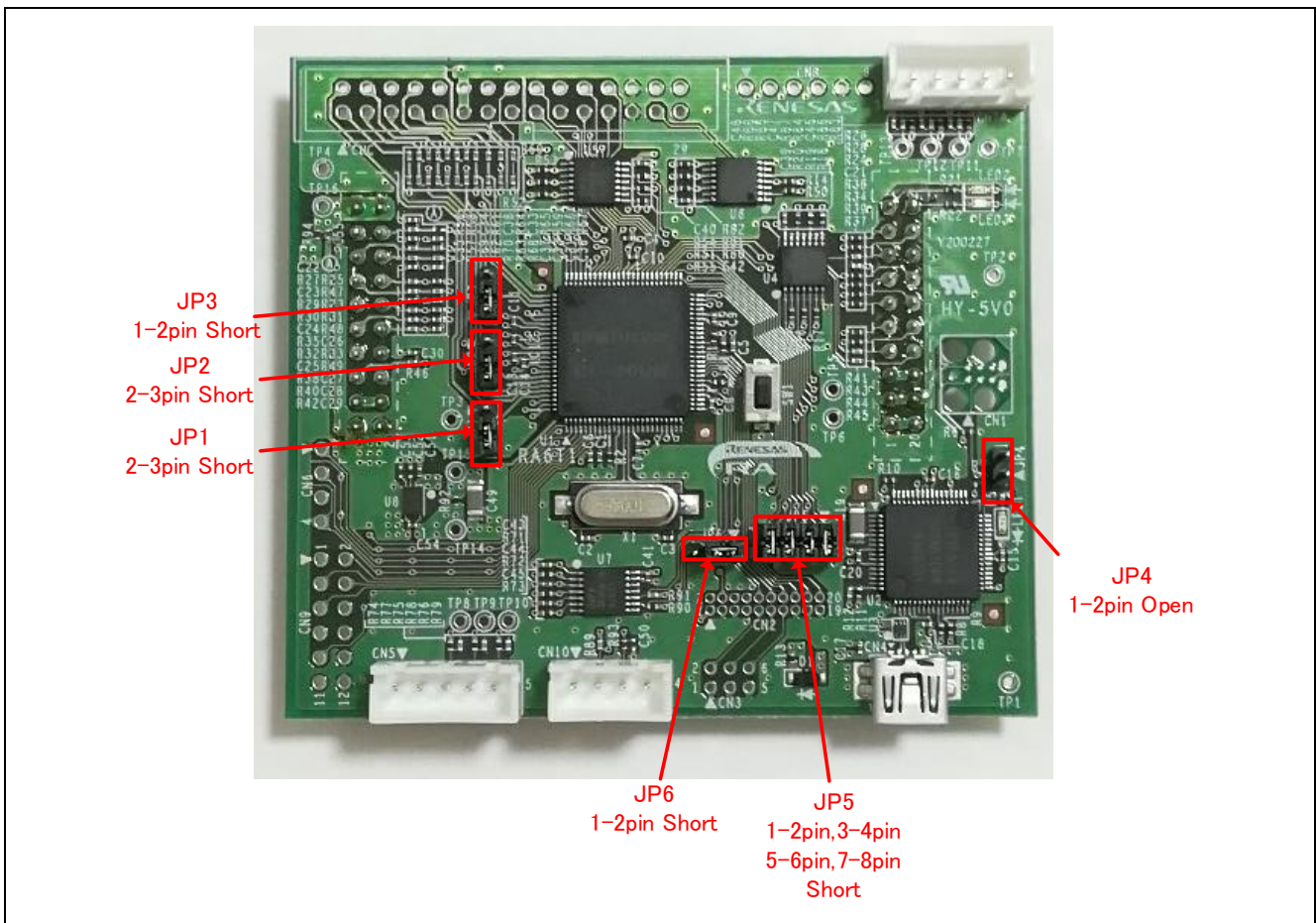

Figure 4-1 Jumper pin setting

## 4.1.2 Connect the motor and the board

Connect the supplied motor and cable following Figure 4-2. Next, connect the plug attached to the cable to CN2 on the inverter board.

Figure 4-2 shows how to connect the supplied motor “TG-55L-KA”

Although the cable has the hall sensor signal connector, if you do not use the hall sensor signal, (if you perform sensorless vector control), you do not need to connect it,



See Figure 4-2 to attach the supplied ferrite core to the motor connection cables.

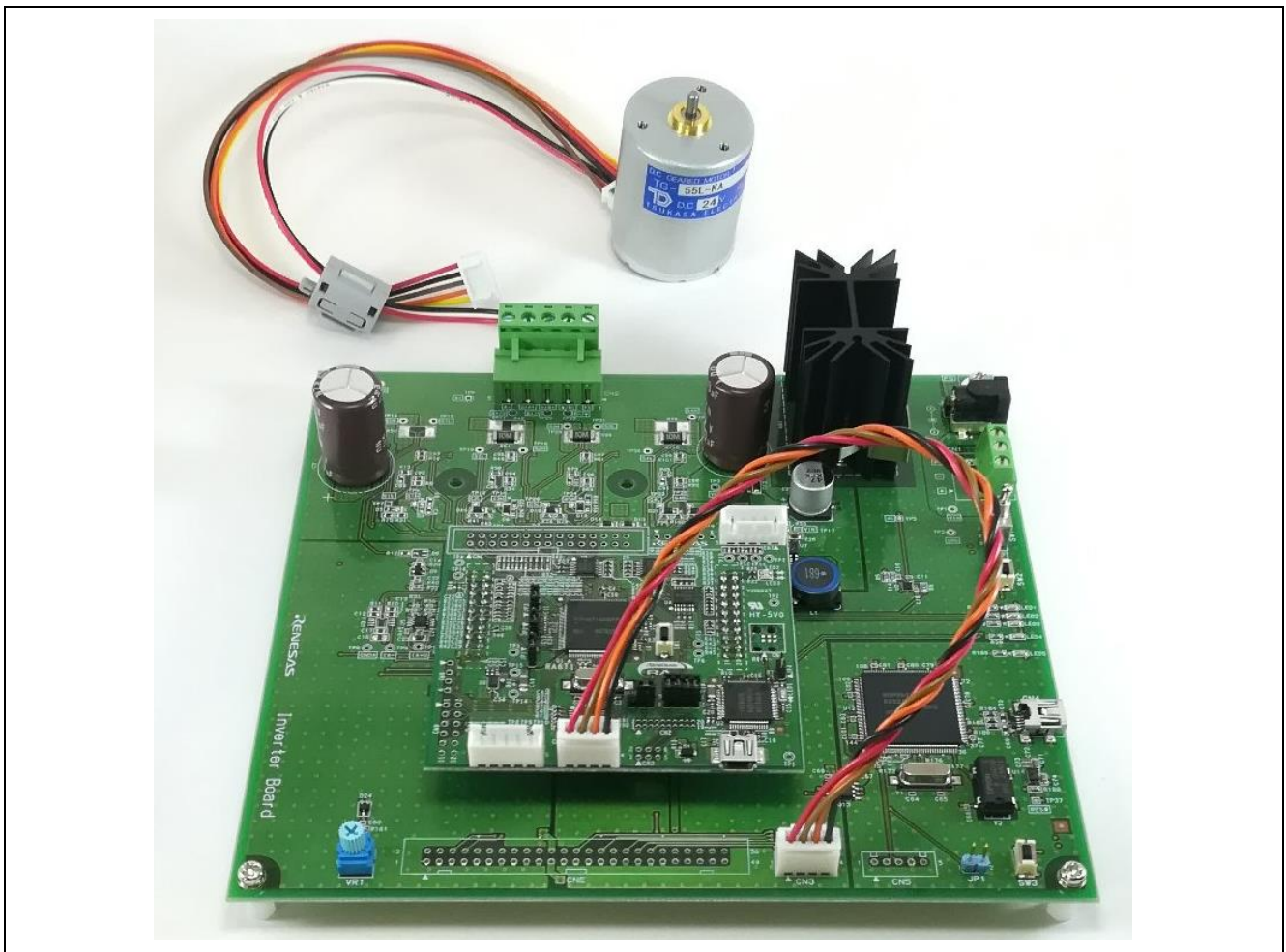

Figure 4-2 Connect cables

## 4.1.3 Connect the stabilized power supply and the cables

This product has the terminal block (CN1) as connector to supply power for the board. Connect positive output of the stabilized power supply with 1 pin of CN1 (“+” silk) and negative output with 2 pin (“-” silk) with the cables.

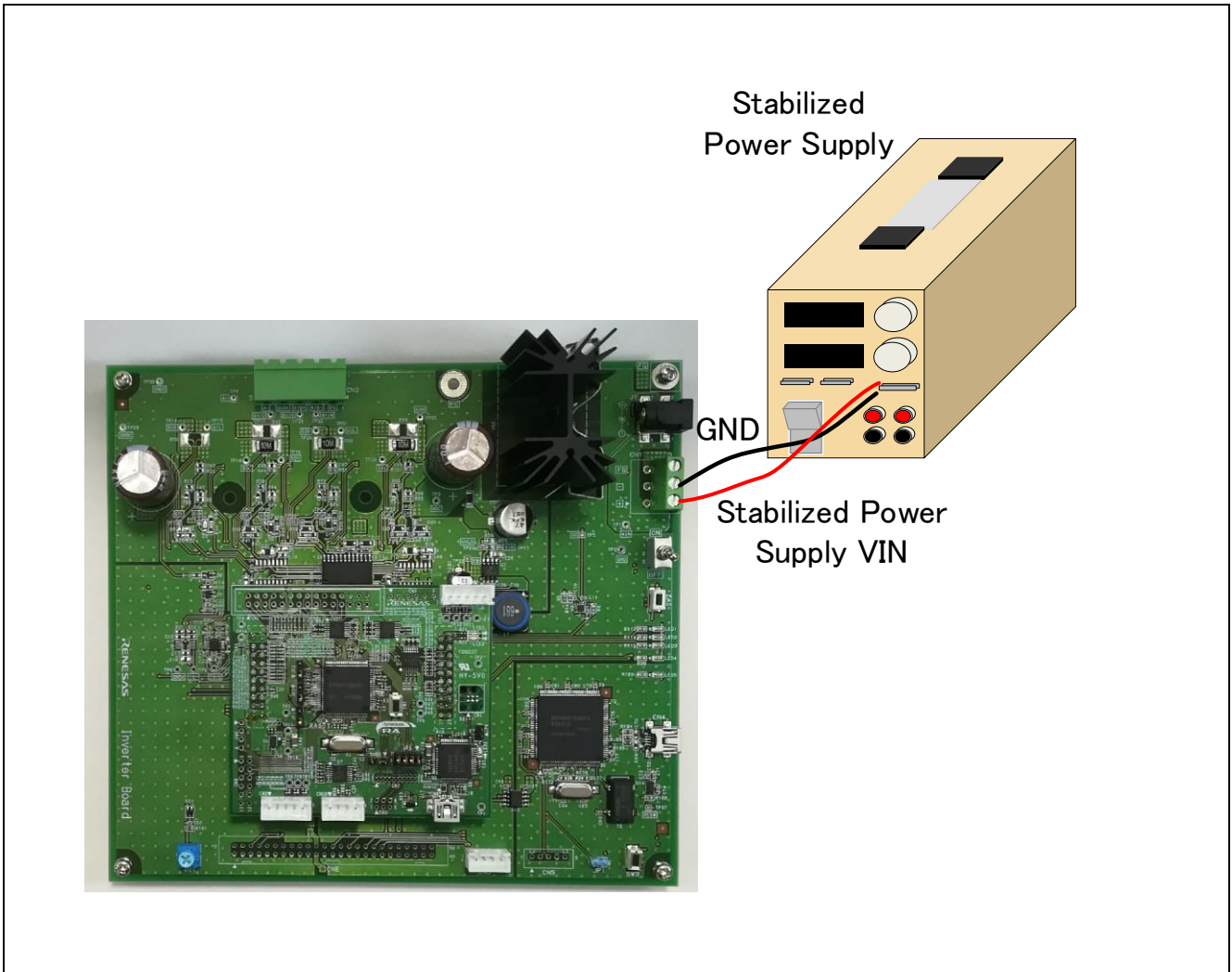

Figure 4-3 Connect the stabilized power supply

#### 4.1.4 Turn on power supply

Use the stabilized power supply, set the output voltage to 24V and the limit current to 1A and turn on power supply. If the voltage drops even for a moment, power supplied for the RA6T1 CPU Card also drops, which causes reset. As a result, the program will halt.

## 4.2 Execute the quick start sample project

Follow the below steps to execute the quick start sample project.

1. After turning on power supply or executing reset, LED1 and LED2 on the inverter board are both off and the motor stops.
2. IF the toggle switch (SW1) on the inverter board is turned on, the motor starts to rotate. Every time the toggle switch (SW1) is pressed, motor rotation starts/stops. If the motor rotates normally, LED1 on the inverter board is on. However, if LED2 on the inverter board is also on, error is occurring.
3. In order to change the direction of the motor rotation, adjust it with the variable resistor (VR1) on the inverter board.
  - Turn the variable resistor (VR1) right : the motor rotates clockwise
  - Turn the variable resistor (VR1) left : The motor rotates counterclockwise
4. If error occurs, LED2 on the inverter board is on, and the motor rotation stops. To restore, the toggle switch (SW1) on the inverter board needs to be turned off, the push switch (SW2) to be turned on, and then SW2 needs to be turned off again.
5. In order to stop the operation check, turn off the output of the stabilized power supply after making sure that the motor rotation has already stopped

## 5. Customize the Quick Start Sample Project

In this product, the user can modify the program using the motor control development support tool by Renesas Electronics, "Renesas Motor Workbench V.x.xx".

This chapter describes the requirements and steps to customize the Quick Start Sample Project.

### Hardware requirement :

- Inverter Board
- RA6T1 CPU Card
- Permanent Magnet Synchronous Motor : TG-55L-KA
- Motor Cable
- Ferrite Core
- Stabilized Power Supply : Output voltage of DC24V or higher, the upper limit of the output current of 1A can be set.
- Power supply cable(x2) : Cables which enable to apply the current of 1A or higher.  
(To connect the stabilized power supply and the inverter board.)
- Communication cable
- USB cable

### Software requirement :

- Microsoft® Windows® 10 Operating System
- Motor Control Development Support Tool "Renesas Motor Workbench V.x.xx"
- USB Driver
- Quick Start example project

### 5.1 Connection method

In order to use the motor control development support tool, "Renesas Motor Workbench V.x.xx", connect the inverter board and PC with the USB cable.

- (1) Connect the communication cable

Connect the SCI connector (CN10) on the CPU card and the connector (CN3) on the inverter board with the communication cable supplied with this product.

- (2) Connect the USB cable

Connect the USB mini B connector on the inverter board and your PC with the USB cable supplied with this product.

Refer to the motor control development support tool, "Renesas Motor Workbench V.x.xx" user's manual, for how to use the tool.

\* V.x.xx is the release version of the applicable tool.

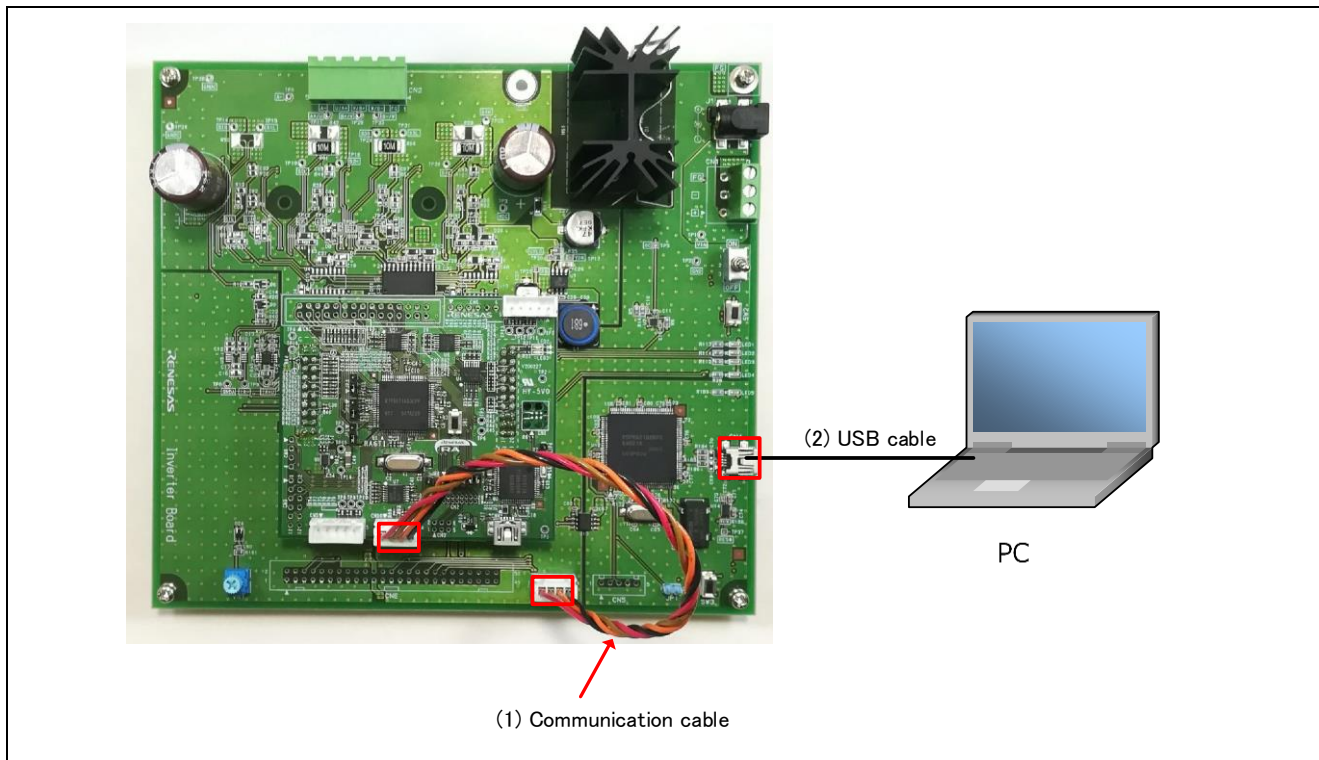

Figure 5-1 Connect cables

## 6. Others

1. As for more details about Motor Control Evaluation System for RA Family - RA6T1 Group, refer to the user's manual, design information and application notes which are available in its web page.
2. Renesas provides some sample projects to conduct demonstration for RA MCU's various functions. These sample projects can be used as good reference materials to start application development. The sample projects for the RA kit are available in the Renesas GitHub Web page, [renesas.com/ra/example-projects](https://renesas.com/ra/example-projects).  
All sample projects provide project file and readme file. In order to enable to write them into this product, after these files are downloaded, the project needs to be built using corresponding tool chain and FSP.



## 7. Website and Support

In order to learn, download tools and documents, apply technical support for RA family MCU and its kit, visit the below Web site.

- RA Product Information [renesas.com/ra](https://www.renesas.com/ra)
- RA Product Support Forum [renesas.com/ra/forum](https://www.renesas.com/ra/forum)
- Renesas Support [renesas.com/support](https://www.renesas.com/support)

# Renesas RA Family Motor Control Evaluation System for RA Family - RA6T1 Group Quick Start Guide

---

Revision History	Motor Control Evaluation System for RA Family - RA6T1 Group Quick Start Guide
------------------	-------------------------------------------------------------------------------

Rev.	Date	Description	
		Page	Summary
1.00	May 8, 2020	-	First Edition

---

Motor Control Evaluation System for RA Family - RA6T1  
Group  
Quick Start Guide

Publication Date: May 8, 2020

Published by: Renesas Electronics Corporation

---

Motor Control Evaluation System for RA  
Family - RA6T1 Group  
Quick Start Guide