

Thyristor · Triac

R07ZZ0011EJ0200
(Previous: REJ27G0020-0100)

Precautions for Use

Rev.2.00
Aug.7.2019

Contents

1. Use of Thyristors.....	2
(1) How to select current rating	2
(2) How to select withstanding voltage class.....	2
(3) Cautions on dv/dt.....	3
(4) Cautions on di/dt.....	3
(5) Measures to prevent false triggering	3
2. Use of Triacs	4
(1) How to select current rating	4
(2) How to select withstanding voltage class.....	4
(3) Selection of CR absorber	5
(4) L load and R load	5
(5) Trigger mode of triacs.....	6
(6) Gate circuit and gate current	7
3. Designing method of Gate Trigger Circuit	9
3.1 Determining Gate Circuit Parameters for Thyristor	9
3.2 How to Prevent False Triggering.....	10
3.3 Example of Designing Gate Trigger Circuit	11
3.4 Designing Gate Circuits for High Rate-of-Rise of On-state Current (di/dt)	12
3.5 Current Concentration at Turn-on	12
3.6 Gate Structure and Spread of Turn-On Area.....	12
4. Thermal Designing for Power Devices.....	13
4.1 Thermal Resistance of Heatsink.....	14
4.2 Device Setting	15
5. Cautions for mounting.....	15
5.1 Cautions for mounting	15
5.2 Cautions for through-hole type devices.....	16
5.3 Cautions for surface-mounted type devices	17
Revision History	18

1. Use of Thyristors

(1) How to select current rating

The permissible currents for thyristors are shown by the average value.

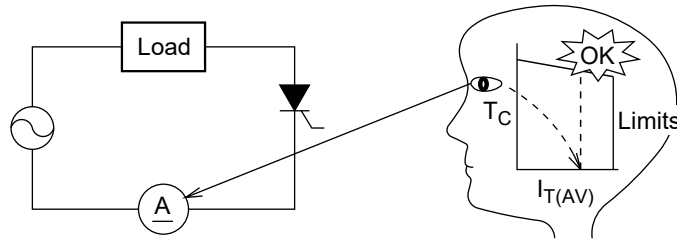

- When no rush current flows (heater, solenoid load)
 Load current × 1.3 to 1.5 ≤ current rating of thyristor
 Example: 1 A × 1.5 = 1.5 → 2 A class thyristors
 Determine the size of heatsink from the catalog.
- When the rush current flows (lamp, transformer, motor load)
 The rush current should be measured and a detailed heat calculation should be made. The current rating is roughly estimated to be twice the calculated value when no rush current flows.
- When pulses are used (capacitor discharge, LC oscillation, short-duration application (less than 10 seconds))
 For appropriate data on thyristors used for pulse applications (gas ignition, leakage protector, CDI, strobe), contact Renesas.

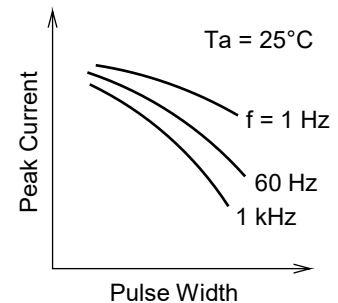

(2) How to select withstanding voltage class

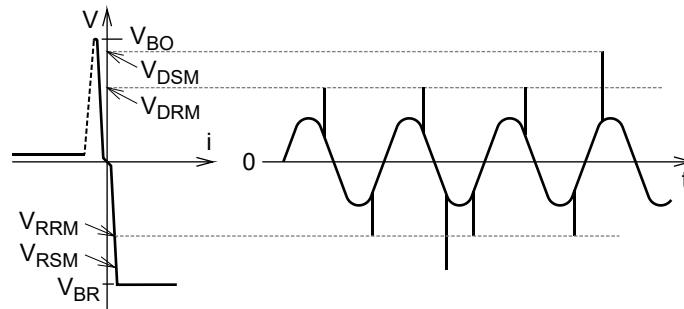

$$V_{DRM} = \text{supply voltage} \times 2.5 \text{ to } 3$$

Selection of voltage items

Supply voltage	Location of use	Withstanding voltage class	V _{DRM} (V)	V _{DSM} (V)
100 V line	Japan (home use)	8/12	400/600	—
120 V line	U.S.			
100 V (120 V) line	Earth leakage breaker	12/16	600/800	— /960
200 V line	Japan (factory use)	12	600	—
240 V line	Europe			
200 V (240V) line	Earth leakage breaker	16	800	960

(3) Cautions on dv/dt

When voltage with large dv/dt is applied to thyristors, CR absorbers should be connected in parallel to the thyristors to suppress the dv/dt applied to the device.

A capacitor of 0.047 μF and a resistor of 33 Ω are generally used for low power thyristors.

For high-sensitivity and low-current thyristors, it is generally recommended to insert a resistor of 1 kΩ between the gate and the cathode. This is also one of the measures against dv/dt.

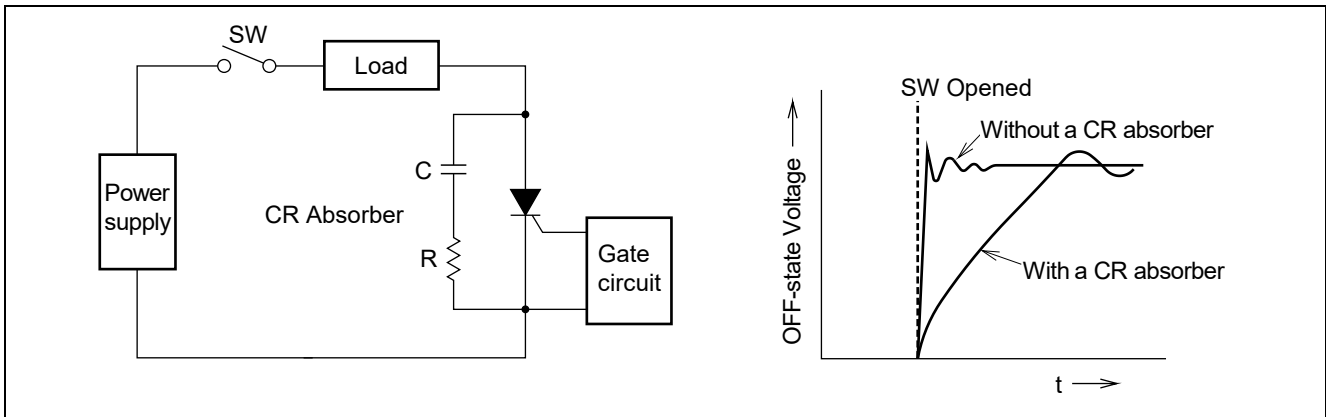

Figure1 To suppress the dv/dt by a CR absorber

(4) Cautions on di/dt

If the rate-of-rise di/dt of current when a thyristor is turned on exceeds the limit, the device may be damaged. In applications such as inverters and choppers which discharge large current when the thyristor is turned on, the di/dt often causes problems, so it is necessary to connect an anode reactor to suppress di/dt.

(5) Measures to prevent false triggering

The causes and measures of false triggering in the trigger circuit are shown in the table below.

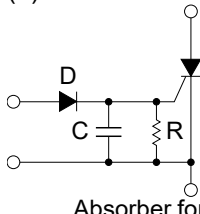
Cause	Preventive measures
Noise to trigger circuit	(1) Stabilize the supply voltage (2) Insert a surge voltage absorber. (3) Avoid the use of noise sensitive circuits such as differentiation circuit. (4) Electromagnetic shielding with chassis etc. to avoid external noise
Noise voltage induced from wiring from the trigger circuit to the gate of the thyristor.	(1) Use shielded wires to transmit the trigger signals. (2) Keep the wires as far as possible from the main circuit wires to avoid electromagnetic coupling.
Feedback noise from the main circuit	(1) Insert an absorber for the gate (see below). (2) Insert a diode (see below).  <p>Values for general use R : 100 to 1 kΩ C : 0.01 to 0.1 μF</p> <p>Absorber for the gate</p>

2. Use of Triacs

(1) How to select current rating

The permissible currents for triacs are shown by the effective values.

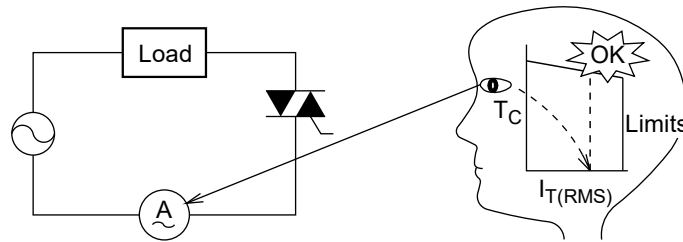

- When no rush current flows (heater load)
 Load current $\times 1.3$ to $1.5 \leq$ current rating of triac
 Example : $6\text{ A} \times 1.5 = 9 \rightarrow 10\text{ A}$ class triacs
 Determine the size of heatsink from the catalog.
- When the rush current flows (lamp, transformer, motor load)
 The rush current should be measured and a detailed heat calculation should be made.
 Provide us with the following values and Renesas will do the calculation for you.

Ambient temperature $T_a = \text{---}^\circ\text{C}$

Peak value of rush current $I_p = \text{---}\text{A}$, waveform if available

Constant current value $I_{T(RMS)} = \text{---}\text{A}$

Operation sequence --- seconds during ON, --- seconds during OFF

Heatsink Material, size, painting, heat resistance $R_{th(f-a)}$ if available.

The following triacs are applicable to the loads when the rush current flows (see Table below).

Load	Rush current	Applicable triacs	
Incandescent lamp	100 V • 800 W	80 A	BCR10FM-12LB
	100 V • 600 W	60 A	BCR12FM-12LB
	100 V • 500 W	50 A	BCR16FM-12LB
Halogen lamp	100 V • 600 W	72 A	BCR16FM-12LB
Microwave oven	100 V • 600 W	80 A	BCR16FM-12LB
General purpose 3-phase induction motor	200 V • 0.75 kW	40 to 45 A	BCR16FM-12LB

(2) How to select withstanding voltage class

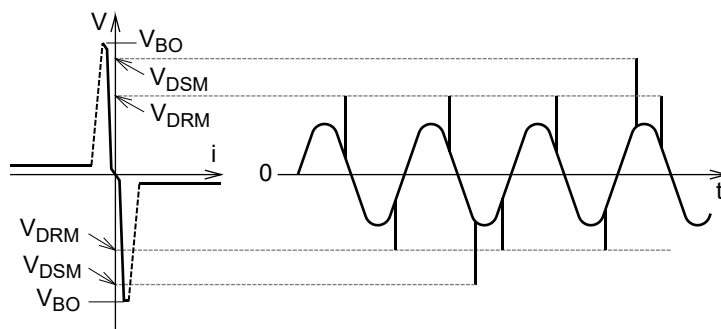

$$V_{DRM} = \text{supply voltage} \times 2 \text{ to } 3$$

Selection of withstanding voltage items

	Supply voltage	Location of use	Withstanding voltage item	V _{DRM} (V)	V _{DSM} (V)
100 V line system	100 V line	Japan (home use)	8/12	400/600	500/720
	120 V line	U.S.			
	100 V (120 V) line	Reversing operation of capacitor motor			
200 V line system	200 V line	Japan (factory use)	12	600	720
	240 V line	Europe	14	700	840
	200 V (240 V) line	Reversing operation of capacitor motor			

(3) Selection of CR absorber

In general, CR absorbers should be connected to suppress the (dv/dt)_c value applied to the device when controlling the inductive load by triacs as shown below. The values for CR absorbers depend on the circuit conditions and sometimes they must be determined by experimentation. In most cases, the (dv/dt)_c value can be suppressed to be less than 2.5 V/μs (supply voltage 100 V) and 5 V/μs (supply voltage 200 V) when C is 0.1 μF and R is 100 Ω.

In addition, please be sure to insert R (47 to 100 Ω) so that the discharge current of capacitor does not cause di/dt destruction of the triacs.

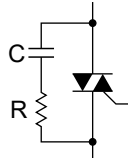

	100 V	200 V
C	0.1 μF, 400 W.V.	0.1 μF, 600 W.V.
R	100 Ω, 1/2 W	100 Ω, 1 W

(4) L load and R load

The commutation characteristics of triacs should be considered according to the load. In the case of inductive load (L load), the phase shift of the current tends to increase the rate of rise of commutating voltage (dv/dt)_c. If (di/dt)_c and (dv/dt)_c at commutation exceed certain values, the triac is spontaneously re-fired to on-state without the gate signal (commutation failure) and become uncontrollable as shown below .

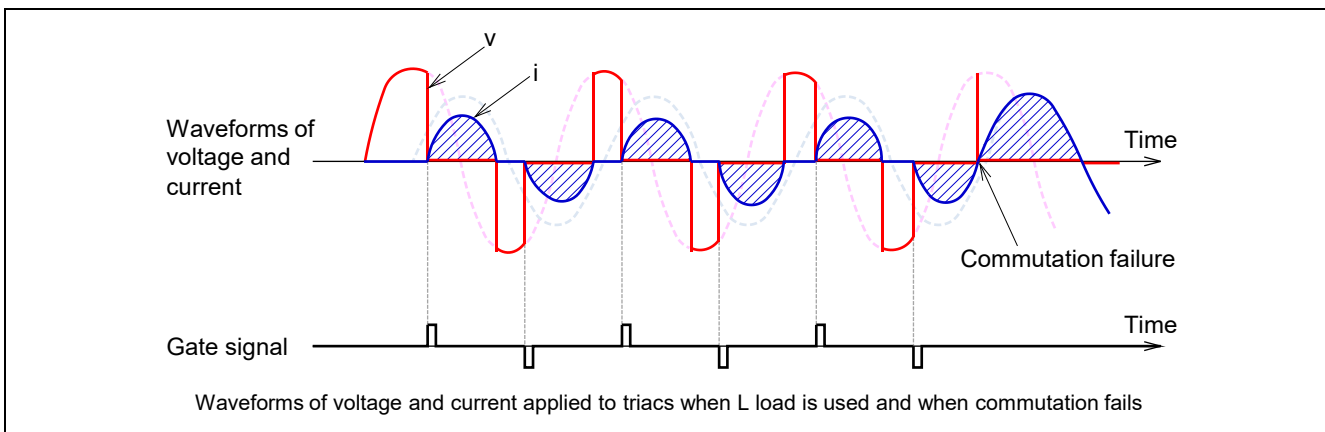

Figure2 Waveforms of voltage and current applied to triacs during L load

To turn off the triac without fail, it is common to select an appropriate device in accordance with the load, but also to connect C and R in parallel to the device to suppress the rate of rise of voltage at commutation.

	Example of load
L Load (inductive load)	Motors, electromagnetic valves, transformers, solenoids
R Load (resistive load)	Heaters, lamps

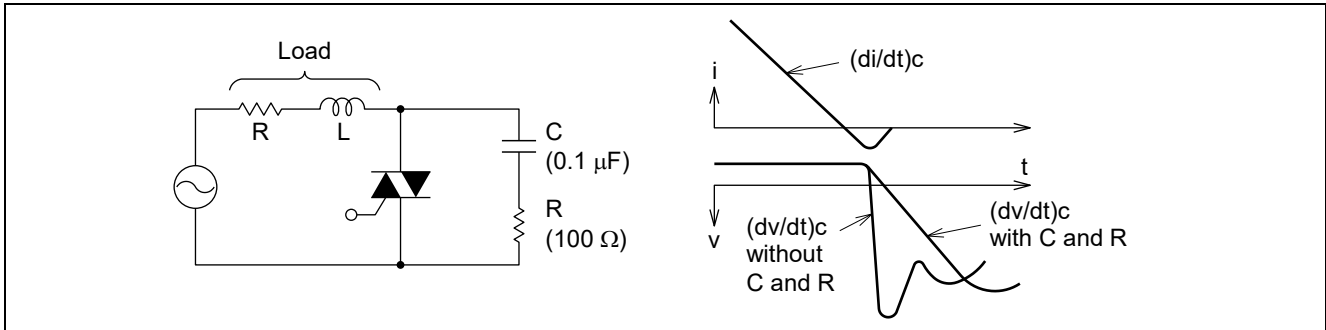

Figure 3 Waveforms during commutation

(5) Trigger mode of triacs

Triacs can be triggered by applying either positive or negative gate signals. In addition, the triac can be turned on by the gate signal not only in the forward direction of the main terminals like a thyristor but also in reverse direction.

There are the following four trigger modes depending on the polarity of Gate and T2 terminals with respect to T1.

However, the IV mode is not guaranteed except for BCR1AM-8P, BCR1AM-14A and BCR08AS-12A.

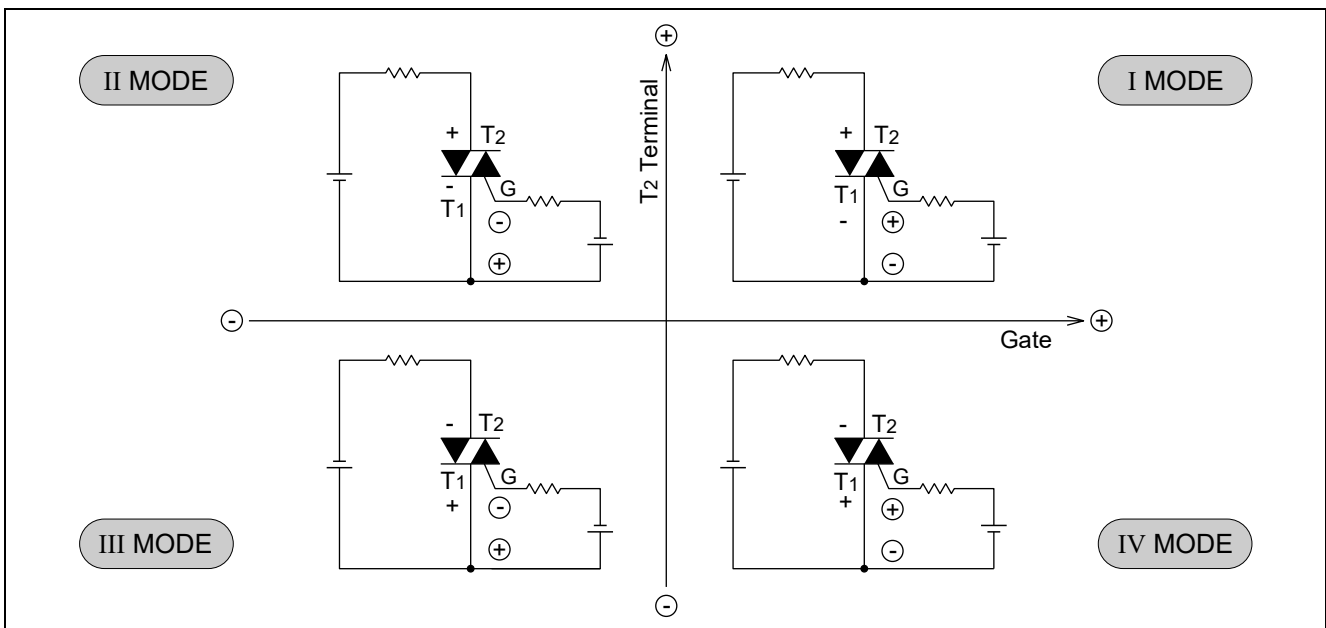

Figure 4 Trigger mode for triacs

(6) Gate circuit and gate current

Generally, a combination of the two trigger modes is used, as in the circuit example in Table 1.

See Figure 5 for how to determine the gate current.

Table 1 Gate circuit

Examples of gate trigger circuit			
I • III Mode	<p style="text-align: center;">SBS • diac</p>	<p style="text-align: center;">Lead relay</p>	<p style="text-align: center;">Photo triac coupler Photo thyristor coupler</p>
II • III Mode	<p style="text-align: center;">22 Ω Pulse transformer</p>	<p style="text-align: center;">IG Vcc IC Tr IC. Transistor</p>	<p style="text-align: center;">4.4 k 1 W 150 Ω 0.47 μ 100 Ω Transistor oscillation</p>
I • IV Mode	<p style="text-align: center;">*1 Vcc IC IC. Transistor</p>	<p style="text-align: center;">BCR1AM-8P etc. Vcc IC Auxiliary trigger by BCR1AM-8P</p>	<p>I • IV mode trigger is possible by using BCR1AM-8P or the like that guaranteed IV mode as an auxiliary triac.</p>

*1: The IV mode (G+, T₂-) is not generally guaranteed except for BCR1AM-8P, BCR1AM-14A and BCR08AS-12A.

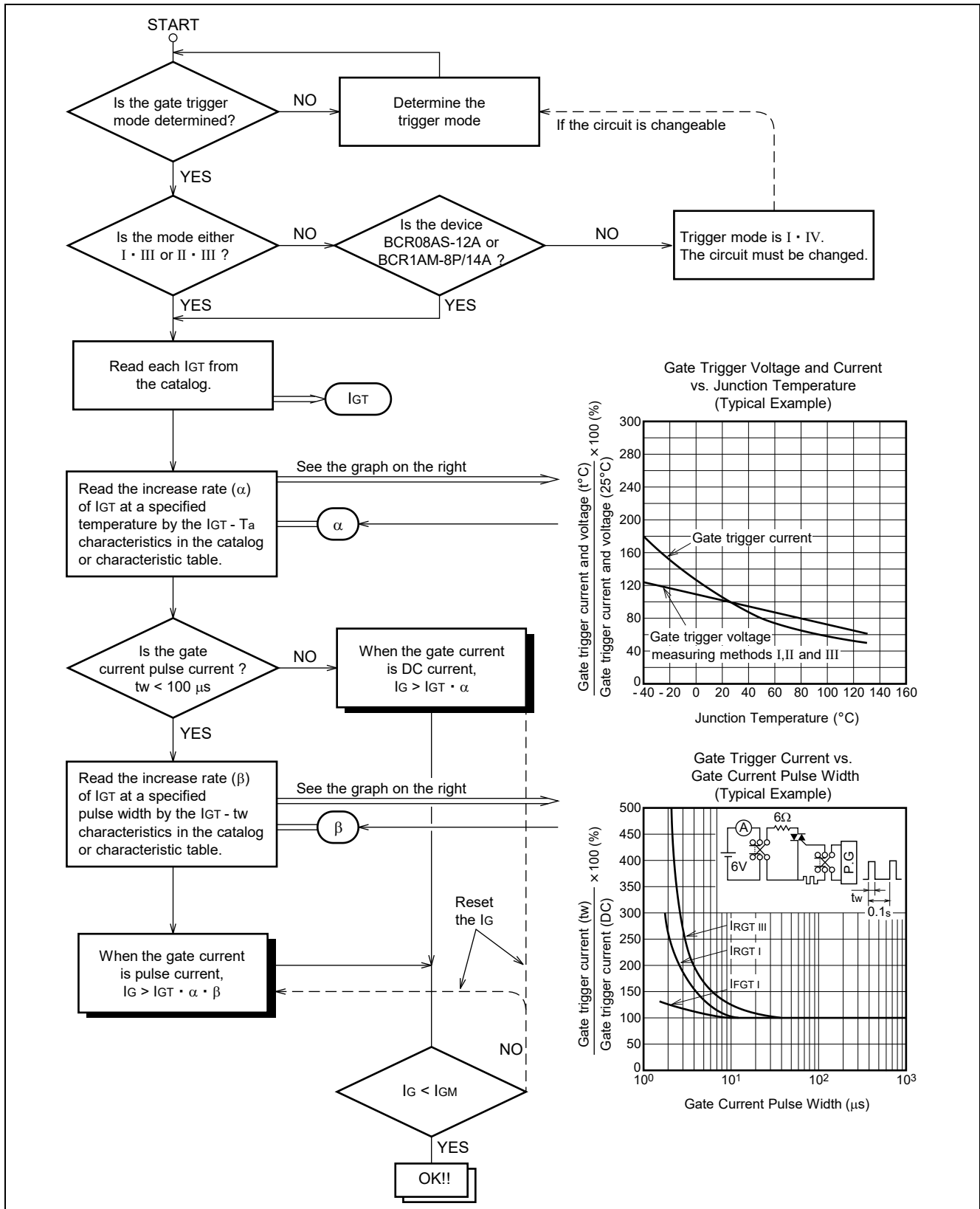

Figure 5 Determination of Gate Current

3. Designing method of Gate Trigger Circuit

This section explains gate circuit for thyristor, including the determination of circuit parameters, how to prevent false triggering, and precautions for circuits with a high rate-of-rise di/dt of on-state current.

3.1 Determining Gate Circuit Parameters for Thyristor

When designing trigger circuits for thyristors, one of the first concerns is to ensure that the devices to be triggered are triggered completely regardless of fluctuations in characteristics. However, attempts to achieve this are hindered by the restrictions in gate power dissipation (peak value, average value), peak gate forward current and voltage, as well as fluctuating values in gate input resistance (gate-to-cathode resistance) that range from a few 10 ohms to a few kilohms. Thus, determining circuit parameters should be carefully considered.

A graph as shown in Figure 6 can be used to help determine circuit parameters. Here, the gate forward current is shown on the horizontal axis, and the gate forward voltage on the vertical axis. The variation range of trigger characteristics and the hyperbolic curve that represents allowable gate power dissipation according to the gate duty interval are plotted in the graph.

In the upper and right areas of the shaded range in this graph, the device will always trigger. The boundary represents the maximum gate trigger current and voltage in the operating temperature range (minimum junction temperature). By contrast, the lower and left area of the shaded range, the device will not trigger. Here, the boundary represents the minimum gate non-triggering current and voltage in the operating temperature range (maximum junction temperature). The graph in Figure 6 is for the thyristor CR25RM-12D (a double logarithmic scale graph is used in the catalog). The maximum gate trigger current for that device is 30 mA ($T_j = 25^\circ\text{C}$), the maximum gate trigger voltage is 1.5 V ($T_j = 25^\circ\text{C}$), and the minimum gate non-trigger voltage is 0.2 V ($T_j = 125^\circ\text{C}$).

A basic gate trigger circuit is considered to connect a constant voltage power supply in series with the current limiting resistor and the gate of thyristor as shown in Figure 7.

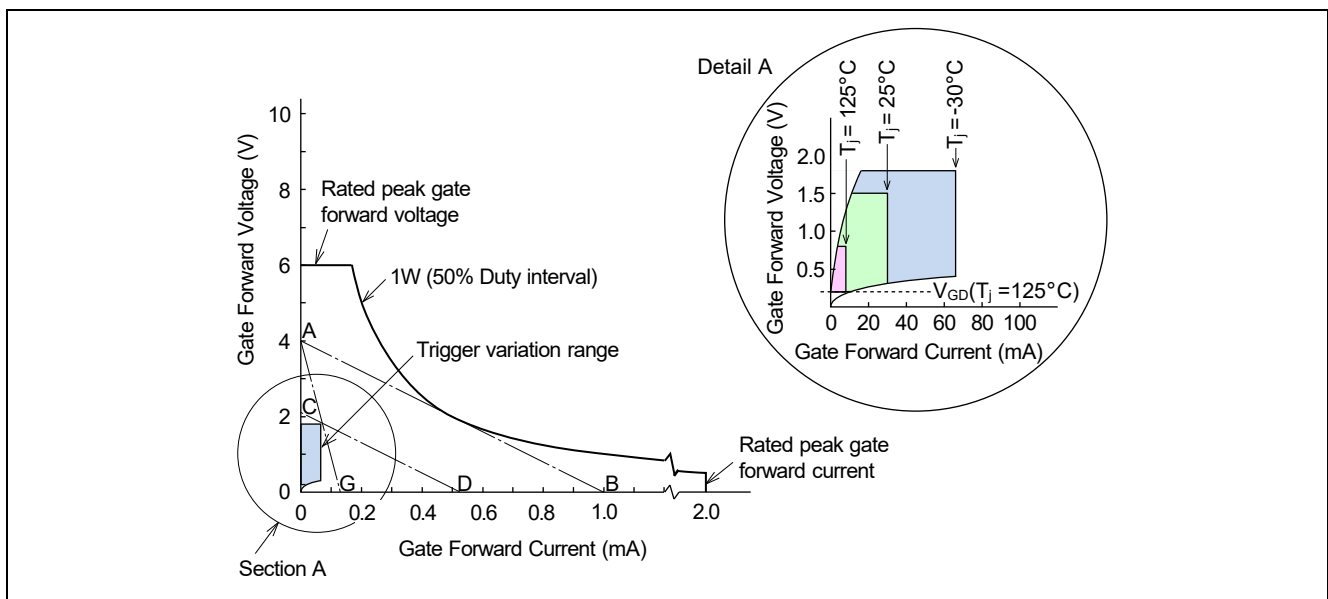

Figure 6 Gate triggering conditions

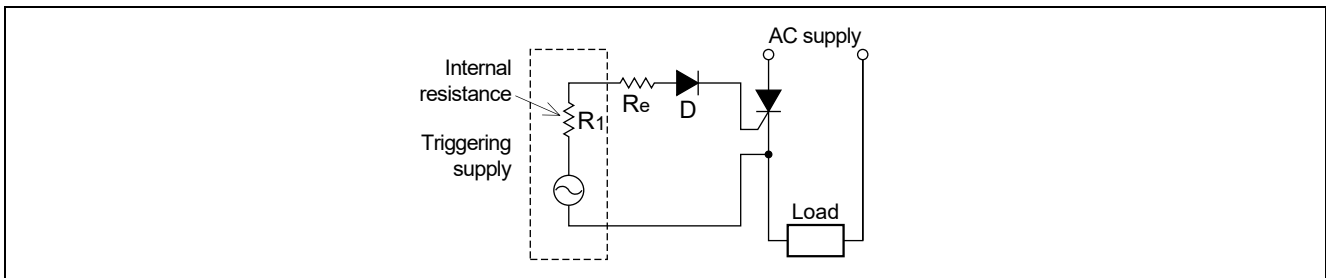

Figure 7 Basic trigger circuit

The main concerns in designing a trigger circuit center around determining proper values for power supply voltage, power supply internal resistance, and current-limiting resistors. These can be determined using the graph in Figure 6, by marking the triggering source voltage value for an open output terminal on the vertical axis, and the value for short-circuit current, when the output terminal is closed, on the horizontal axis, and then connecting the two points. This straight line is called the “gate load line”, and no matter how much gate input resistance inside the thyristor fluctuates, the voltage and current applied to the gate will be values on this gate load line. Consequently, as long as this load line does not cross the shaded range, and remains below the rated gate power dissipation curve, all devices will trigger completely and safely. If the load line crossing the shaded range, some devices may not always trigger, and if crossing the rated gate power dissipation curve, the power dissipation at the gate of some devices will be exceeded the rating.

3.2 How to Prevent False Triggering

Thyristor has high gate control gain, so it can be turned on by a very small gate current (several micro-amperes to several tens of milli-amperes) to control a large current of several amperes to several kilo-amperes. On the other hand, the gate is so sensitive that noise voltage may cause false triggering. One cause of such false triggering is that a large current flowing in the main circuit near the gate circuit induces a noise voltage in the gate line by electromagnetic effect, and special care must be taken in multiphase circuits. The following methods are recommended to prevent false triggering.

- (1) Keep gate lead lines far enough away from the main circuit lines to prevent voltage induction.
- (2) Insert a capacitor (0.01 to 0.1 μF) between the gate and cathode to absorb noise voltage.
- (3) Avoid using the common cathode line of the main circuit and the gate circuit and connect them directly to the device cathode.
- (4) Use shielded wires or two core flat cables for gate lines to inhibit the electromagnetic induction effect.
- (5) Connect a silicon diode in series with the gate and use the voltage rise (approx. 0.7 V) to block the noise voltage.
- (6) Apply negative bias to the gate with respect to the cathode to block noise voltage.

The above points summarize the various methods available. Figure 8 shows these points diagrammatically.

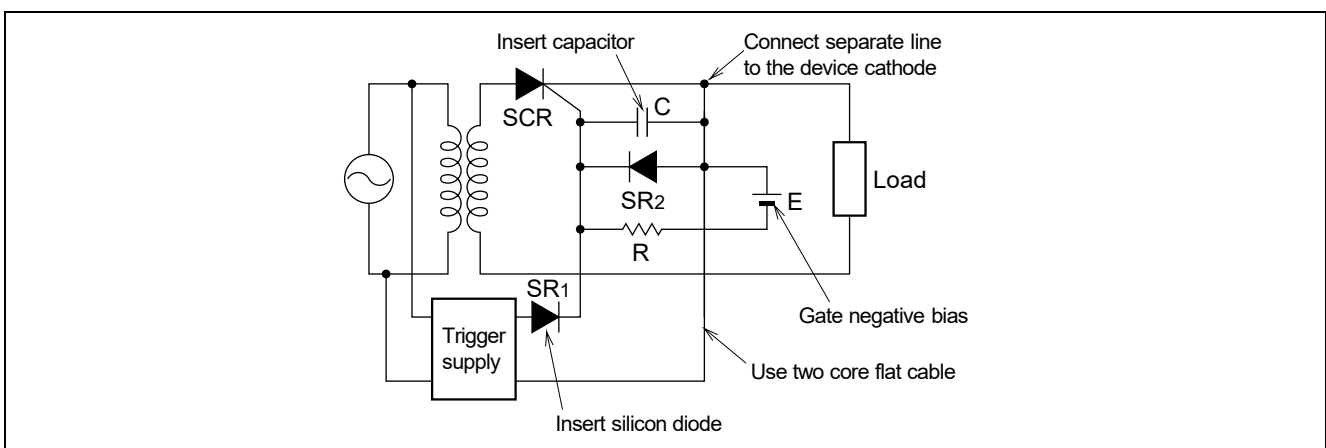

Figure 8 Trigger circuit

3.3 Example of Designing Gate Trigger Circuit

It is explained that an example of designing a gate trigger circuit for thyristor CR25RM-12D synchronized with the main circuit voltage as shown in Figure 9. The silicon diode (SR) blocks negative cycles of the AC power supply for triggering. Unlike germanium diodes, the threshold voltage of silicon diodes is as high as 0.7 V, which helps prevent false triggering. The trigger supply voltage is rectified to half wave by the silicon diode (SR), so the gate duty period is 50%. Draw the allowable power dissipation curve for the 50% duty period on the gate load line graph in Figure 6. The average rating of gate power dissipation for CR25RM-12D is 0.5 W, so the allowable average gate power dissipation during 50% duty period will correspond to the 1 W according to the following formula.

$$\text{Average gate input} \times \frac{100}{\text{duty interval (\%)}}$$

If this value exceeds rated peak gate power dissipation (5 W for CR25RM-12D), use 5 W.

For example, when the RMS value for trigger supply voltage is 4 V, drawing the gate load line AB down from 4 V on the vertical axis as a tangent to the allowable power dissipation curve (for 50% duty interval), it will intersect the horizontal axis at 1.0A, which is the short circuit current. The gradient of this line (4 V/ 1 A) indicates that the resistance value must be over 4 Ω. Assuming a resistance value of 4 Ω, draw another load line in parallel with line AB, which corresponds to another supply voltage instantaneous value. As the trigger supply voltage rises from zero, the gate load line moves upward parallel to the AB line. When it does not cross the shaded range, all devices will trigger. This gate load line is marked CD on the graph, indicating that the gate supply voltage needs to be 2.1 V or more.

In this method where the gate trigger supply voltage is a sine wave, the variation of the firing phase angle tends to be large depending on the individual characteristics of the device. The variation can be reduced by using a supply voltage with a high rate-of-rise. Therefore, in practice, a higher voltage power supply may be used, and a Zener diode clips the voltage to 6 V or less.

When using a magnetic amplifier or similar device as a gate trigger power supply, the voltage waveform applied to the gate is close to a square wave, so the variation in firing phase angle becomes smaller. When these types of waveforms are applied, draw the gate load line based on the peak value.

Circuit parameters are determined as described above. In addition, to prevent false triggering, a capacitor (approx. 0.047 μF) is inserted between the gate and the cathode. In this circuit, the silicon diode used to rectify the trigger voltage to a half-wave also helps prevent false triggering by suppressing noise. The gate line should be connected directly to the gate and cathode terminal of the device using a two core flat cable or shielded cable to minimize electromagnetic induction effect.

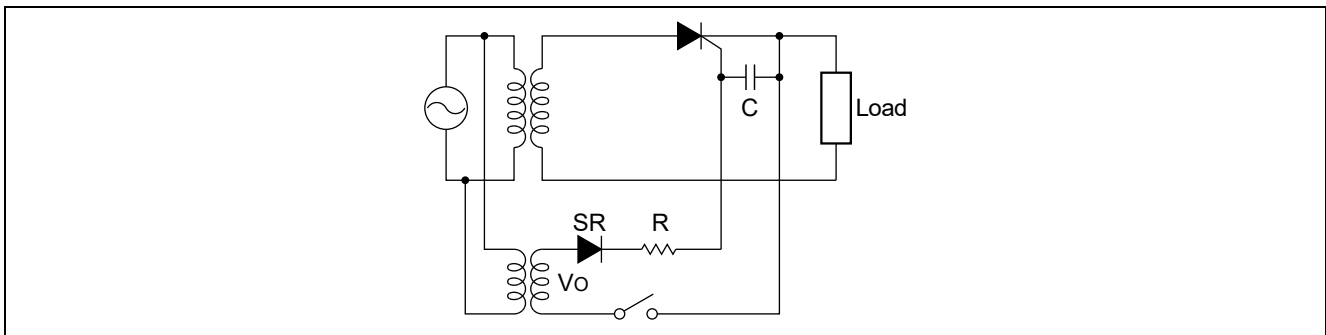

Figure 9 Example of Trigger circuit wiring diagram

3.4 Designing Gate Circuits for High Rate-of-Rise of On-state Current (di/dt)

In this section, a gate circuit design method used for applications such as motor-controllers, inverters, and DC choppers in which a large inrush current with high rate-of-rise of current (di/dt) flows at turn-on will be described.

Thyristor turns on whenever the gate current and voltage higher than the gate trigger characteristics are applied, but the turn-on time is affected by the amplitude and width of the gate current, the on-state current, the off-state voltage between anode and cathode, and the characteristics of the load. In applications where a large inrush current with high di/dt flows at turn-on, local temperature rise will occur in the thyristor, and the characteristics may become unstable or even deteriorate. These problems can be solved through trigger circuit design, and more reliable operation can be achieved.

3.5 Current Concentration at Turn-on

Considering the turn-on process inside a thyristor, the time required for the conduction area to spread over the entire junction region after the signal enters the gate is considerably longer than the turn-on-time. At the beginning of the process of spreading the conduction area, carriers are locally injected from the cathode closest to the gate and turn-on starts from there. At this time, if the current concentrates on the small spot, local temperature rise will occur, and the characteristics may deteriorate. The solution to prevent local current concentration is to suppress the rate-of-rise di/dt of the load current below a certain value.

In general, for applications where the rate-of-rise di/dt of load current is low, such local hot-spots are not a problem.

In applications such as motor-controllers, inverters, and DC choppers in which a large inrush current with high rate-of-rise of current (di/dt) flows, the hot-spots become a problem. Extra care should be taken to solve high di/dt problems during turn-on, when using devices designed for large switching current.

3.6 Gate Structure and Spread of Turn-On Area

The spread speed of the conduction area is generally considered to be approximately $0.1 \text{ mm}/\mu\text{s}$. However, the time required for the conduction area to spread over the entire effective conducting region depends on the gate structure and the gate current.

The turn-on of thyristor starts at a junction where it is most easily triggered.

When the gate current is small, the initial conduction area may be local, but if a sufficiently large gate current flows, the initial conduction area will spread like a band as shown in Figure 10. Not only is the initial conduction area significantly increased, but the spread time of the conduction area can be shortened and local heating in the junction can be reduced. Consequently, applying a sufficiently large gate current (High Gate Drive) can help solve the di/dt problems and can significantly improve the spread of conduction area.

In general, applying current and voltage that exceed the gate trigger characteristics to gate of the thyristor will turn the device on, and the device will continue to operate stably under these conditions unless the di/dt of load current is particularly high. However, considering the temperature dependency of the gate characteristics and the current concentration at turn-on, driving with a large gate current rather than just the characteristic value will shorten the turn-on delay time and enhance the reliability of the device.

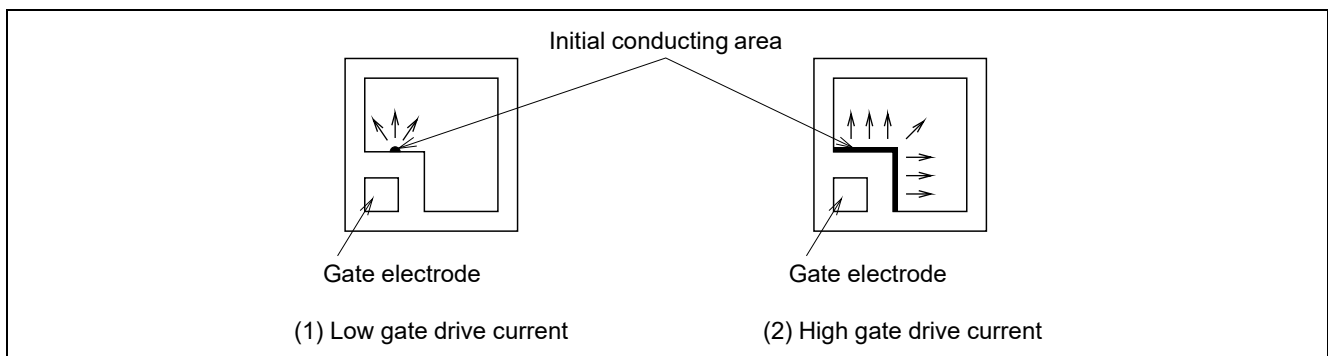

Figure 10 Turn-on area spreading

4. Thermal Designing for Power Devices

Especially for power semiconductor devices, it is necessary to take measures to dissipate the heat generated in the device to the environment. Because the natural heat dissipation from only the outer casing of the device is not sufficient, and the junction temperature of the device may exceed their allowable limits. There are several methods to dissipate heat, including natural convection cooling, forced air cooling, liquid cooling, oil cooling, evaporative cooling. Heat transfer can be modelled by analogy to an electrical circuit as shown in the table 2, where thermal resistance is represented by resistor.

Table 2 Analogy between electrical circuit and equivalent thermal circuit

Electrical circuit	Equivalent Thermal circuit
Voltage (V)	Temperature (°C)
Current (A)	Power dissipation (W)
Resistance (Ω)	Thermal resistance (°C/W)

The equivalent thermal circuit is shown in Figure 11. The figure shows equivalently how the heat generated at the junction of the device flows through the thermal resistance between the junction and the case, between the case and the heatsink, and between the heatsink and the ambient, and dissipates to the ambient.

Considering $P(W)$ to be the heat generated at the junction, the following equation can be derived.

$$T_j - T_a = P(R_{th(j-c)} + R_{th(c-f)} + R_{th(f-a)})$$

T_j : Junction temperature (°C)

T_a : Ambient temperature (°C)

P : Power dissipation within the device (W)

$R_{th(j-c)}$: Junction to case thermal resistance (°C/W)

$R_{th(c-f)}$: Case to heatsink thermal resistance (°C/W)

$R_{th(f-a)}$: Heatsink to ambient thermal resistance (°C/W)

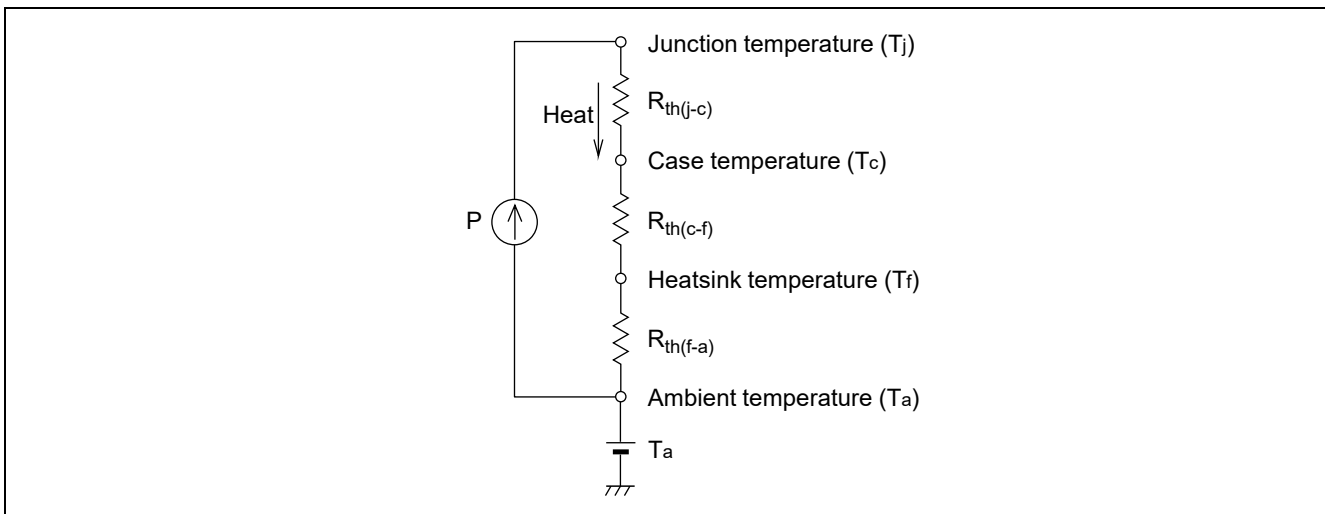

Figure 11 Equivalent thermal circuit

The design procedure is as follows. First, design a rectifier circuit and select devices based on electrical conditions. Therefore, maximum rating of junction temperature, junction-to-case thermal resistance and power dissipation at the junction can be determined, and the case-to-heatsink thermal resistance is also roughly determined. After that, if the maximum ambient temperature ($T_{a(max)}$) in the operating environment will be determined, the only variable that can be selected is the heatsink-to-ambient thermal resistance. This value is roughly determined by the size of the heatsink, but if the size of the heatsink is not appropriate, it may be necessary to change to another current rated device or another cooling method.

4.1 Thermal Resistance of Heatsink

The thermal resistance of a heatsink depends not only on its size, but also on shape, material, surface configuration (surface finish, painted or bare, etc.) and orientation. Other factors such as the temperature difference between heatsink and ambient, the airflow speed at heatsink surface, the airflow conditions and the temperature of surrounding objects also influence thermal resistance.

Thermal resistance data of flat heatsinks are given in figure 12. For example, when $R_{th(f-a)}$ of $3^{\circ}C/W$ is required, the data indicates that an unpainted aluminum plate with a thickness of $t2.3$ mm and an area of 220 cm^2 , that is, about 15 cm square, is suitable.

Measured data for heatsinks on the market is available from the individual manufacturers. Transient thermal impedance for aluminum plates of various size is illustrated in Figure 13.

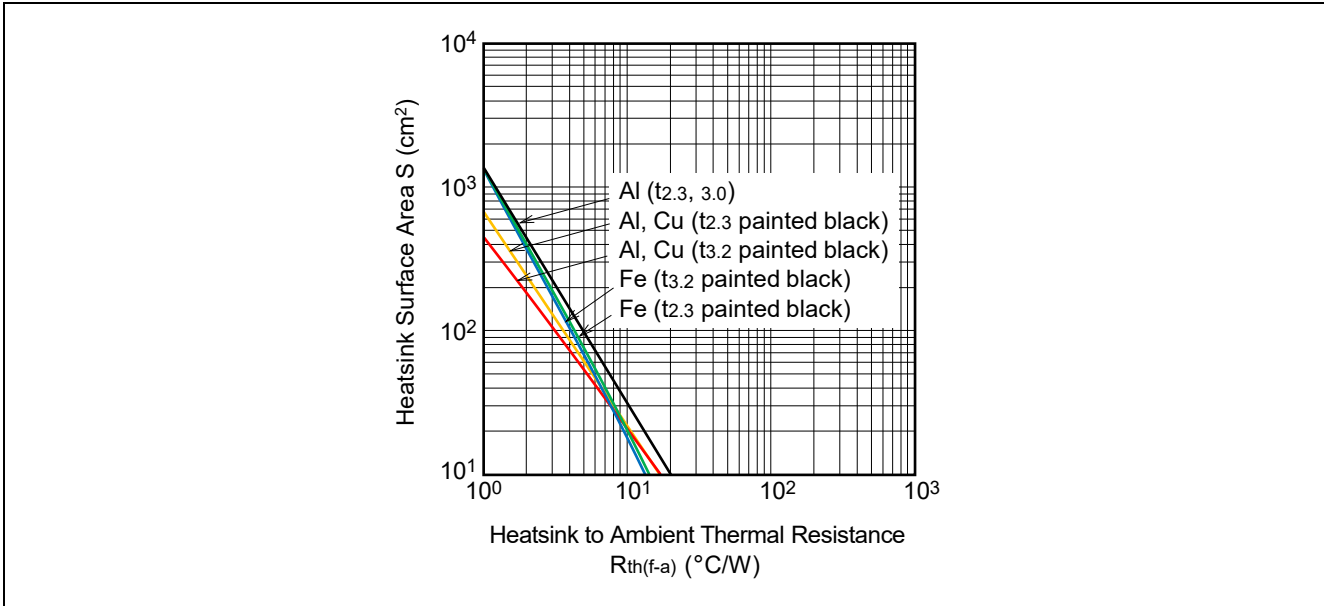

Figure 12 Heatsink Surface Area–Heatsink to Ambient Thermal Resistance Characteristics

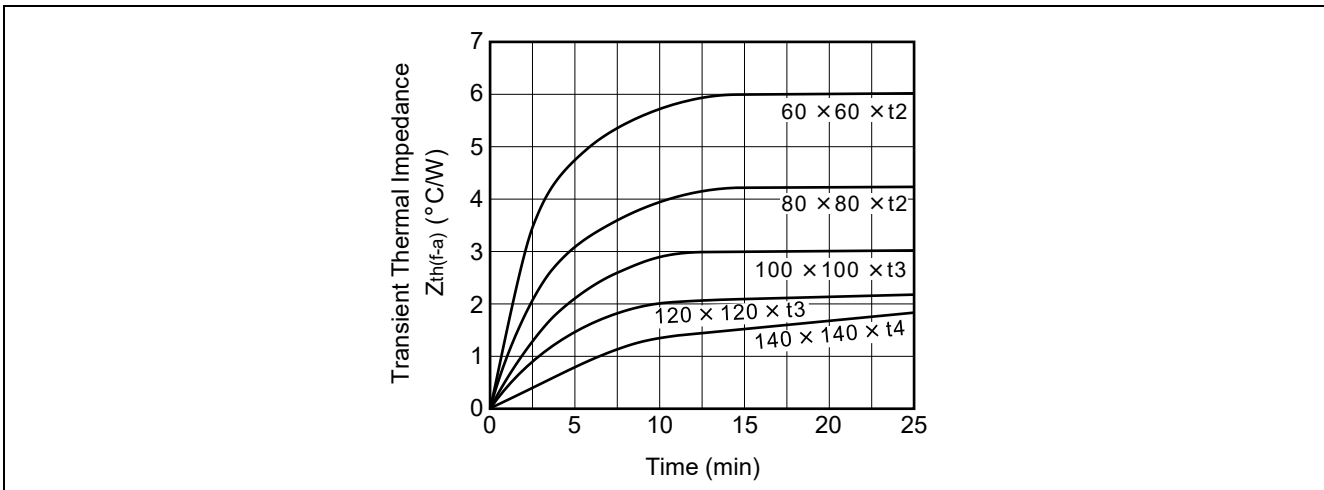

Figure 13 Transient thermal impedance for aluminum plate heatsinks (single plate mounted perpendicular, painted black, self-cooling, temperature in center of fin $60^{\circ}C$) (actual measurements)

4.2 Device Setting

The thermal resistance $R_{th(c-f)}$ between the device and heatsink (contact thermal resistance) depends heavily on factors such as materials of objects in contact, contact surface roughness, contact area, interposed material, and contact pressure. Whenever mounting a device, minimizing $R_{th(c-f)}$ should be considered,

When mounting a device to a heatsink, applying grease to the contact surface not only reduces contact thermal resistance but also prevents corrosion of the contact surface. However, it is important to select grease that does not deteriorate over the years and operating temperature range. When using an aluminum heatsink, it is necessary to remove the oxidized layer on the contact surface with a wire brush. Grease is usually applied only to the contact surface and not to the threads.

The contact thermal resistance in each package is as shown in Table 3.

A torque wrench or torque driver must be used to mount the device, and tighten the screws to the specified torque.

Table 3 Contact thermal resistance information Package type

Package Type	Thread Diameter	Recommended torque		Contact thermal resistance (°C/W)
		N • m	(kgf • cm)	
TO-3P	M3	0.59	(6)	0.3
TO-220ABA	M3	0.49	(5)	1.0
TO-220F	M3	0.49	(5)	0.5
TO-220FPA	M3	0.49	(5)	0.5

Notes: Values for contact thermal resistance applicable for mounting, using joint compound and torque to recommend values.

5. Cautions for mounting

5.1 Cautions for mounting

- (1) When mounting the TO-220 device to the heatsink, the surface of the heatsink should be smooth enough (finish level : 6S ∇∇∇ or higher) without burrs or metal chips .
- (2) A torque wrench or torque driver must be used to mount the device, and tighten the screws to the specified torque.
- (3) Apply silicone grease to the contact surface to improve thermal conductivity from device to heatsink.
- (4) Lead terminals of through-hole devices should be soldered according to the following conditions.
 - 1) Soldering should be at least 2 mm away from the molded part.
 - 2) For manual soldering, use a soldering iron of 80 W or less, and the soldering temperature should not exceed 350°C and the time should be within 3 s.
 - 3) For wave soldering (flow soldering), the solder temperature should not exceed 260°C and the immersion time should be within 10 s.
- (5) When mounting a non-insulated TO-220 package in electrical conduction with a heat sink or when mounting an isolated TO-220 package, the diameter of the through hole of the heatsink should be approximately $\phi 3.2$ to $\phi 3.8$.

5.2 Cautions for through-hole type devices

Care should be taken as follows when using a through-hole type device.

(1) Stress to electrode leads

Excessive stress given to electrode leads in a device may damage the device. The load as shown by the arrow in Figure 14 should be less than 9.8 N.

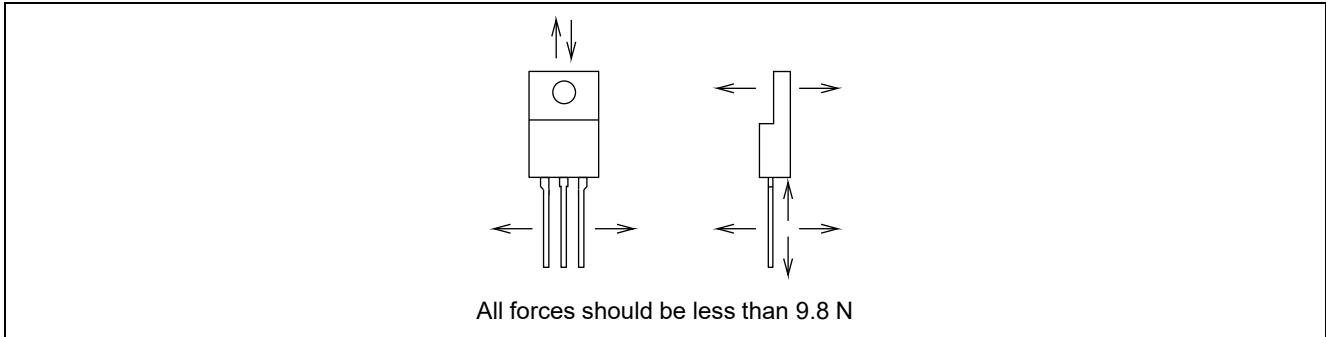

Figure 14 Stress to electrode leads

(2) Cautions for lead forming

Care should be taken as follows when forming external leads due to the arrangement of parts in the equipment.

- It is desirable to use a dedicated forming machine to avoid the stress as shown in Figure 14. Alternatively, prepare two narrow tipped radio pliers, fix the base of the lead by one pliers, and bend the lead on the tip side by another pliers.
- When bending the lead in the lateral direction, bend it at a thin part of the lead or at a point at least 2 mm away from the main body and its angle should be less than 30 degrees as shown in the Figure 15.
- When bending the lead perpendicular to the marking surface, bend it at a point at least 2 mm away from the main body as shown in the figure 16.

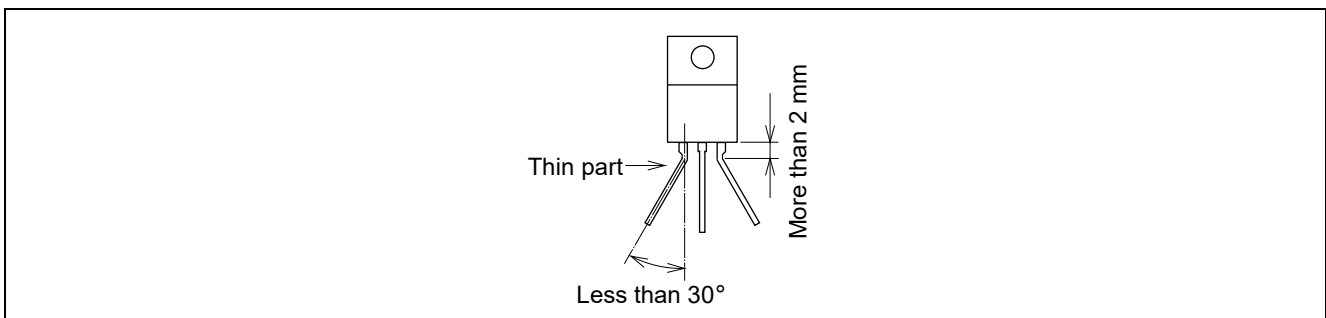

Figure 15 Bending leads in lateral direction

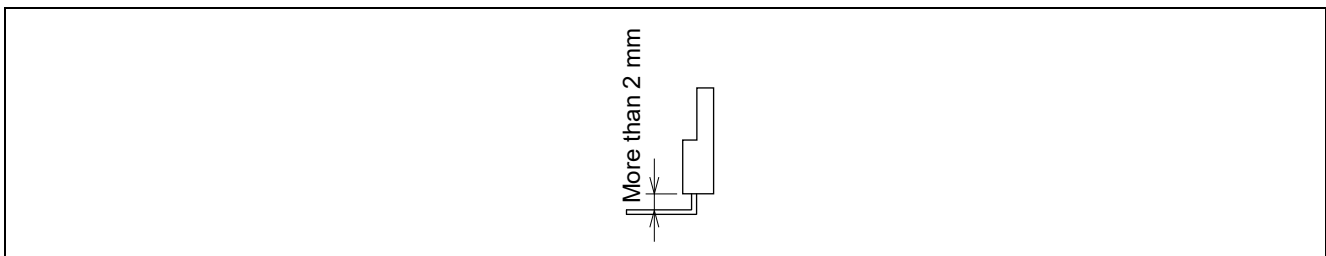

Figure 16 Bending leads in perpendicular direction

5.3 Cautions for surface-mounted type devices

(1) Allowable power dissipation and recommended mounting pad

Because the allowable power dissipation of surface-mounted devices depends on the materials of the circuit board and wiring pattern, etc., it is recommended to test the heat dissipation after mounting. Typical mounting pad patterns for MP-3A, TO-263, UPAK packages are shown in the Figure 17.

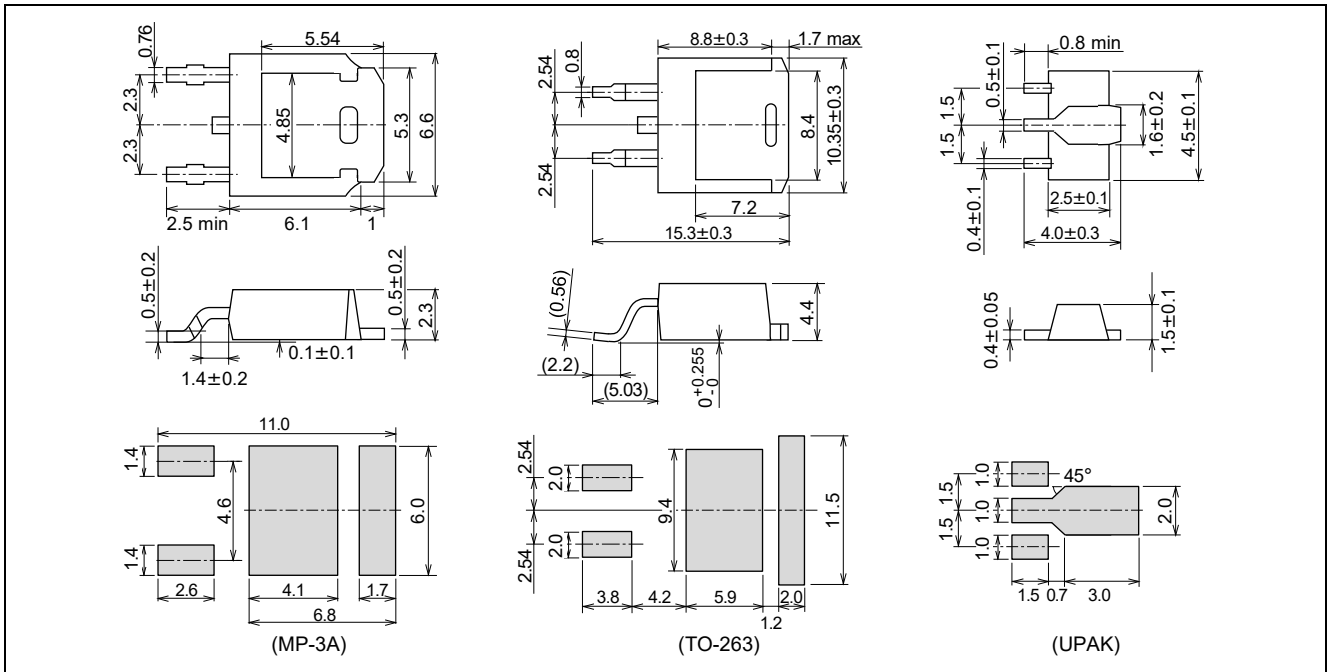

Figure 17 Recommended mounting pad

(2) Reflow method

The recommended soldering method for surface-mount devices is reflow soldering. The recommended temperature profile depends on the product, please contact us.

(3) Cleaning PCB (Printed Circuit Board)

When cleaning the PCB to remove flux after soldering, observe the following instructions.

1) When using an ultrasonic cleaner, make sure that the ratings are as follows.

- Recommended conditions
 - Frequency 28 kHz max
 - Output of ultrasonic 20 W/l max
 - Cleaning time 30 sec max
- The ultrasonic vibrator should not be in contact with the PCB and devices. Do not allow the devices to be resonant at the vibrating frequency.

Revision History

Rev.	Date	Description	
		Page	Summary
1.00	Jan.26.2005	—	First edition issued
2.00	Aug.7.2019	—	<ul style="list-style-type: none">· Added table of contents· Updated to latest part number and package· Updated according to lead free· Corrected minor errors

Notice

1. Descriptions of circuits, software and other related information in this document are provided only to illustrate the operation of semiconductor products and application examples. You are fully responsible for the incorporation or any other use of the circuits, software, and information in the design of your product or system. Renesas Electronics disclaims any and all liability for any losses and damages incurred by you or third parties arising from the use of these circuits, software, or information.
2. Renesas Electronics hereby expressly disclaims any warranties against and liability for infringement or any other claims involving patents, copyrights, or other intellectual property rights of third parties, by or arising from the use of Renesas Electronics products or technical information described in this document, including but not limited to, the product data, drawings, charts, programs, algorithms, and application examples.
3. No license, express, implied or otherwise, is granted hereby under any patents, copyrights or other intellectual property rights of Renesas Electronics or others.
4. You shall not alter, modify, copy, or reverse engineer any Renesas Electronics product, whether in whole or in part. Renesas Electronics disclaims any and all liability for any losses or damages incurred by you or third parties arising from such alteration, modification, copying or reverse engineering.
5. Renesas Electronics products are classified according to the following two quality grades: "Standard" and "High Quality". The intended applications for each Renesas Electronics product depends on the product's quality grade, as indicated below.
 - "Standard": Computers; office equipment; communications equipment; test and measurement equipment; audio and visual equipment; home electronic appliances; machine tools; personal electronic equipment; industrial robots; etc.
 - "High Quality": Transportation equipment (automobiles, trains, ships, etc.); traffic control (traffic lights); large-scale communication equipment; key financial terminal systems; safety control equipment; etc.

Unless expressly designated as a high reliability product or a product for harsh environments in a Renesas Electronics data sheet or other Renesas Electronics document, Renesas Electronics products are not intended or authorized for use in products or systems that may pose a direct threat to human life or bodily injury (artificial life support devices or systems; surgical implantations; etc.), or may cause serious property damage (space system; undersea repeaters; nuclear power control systems; aircraft control systems; key plant systems; military equipment; etc.). Renesas Electronics disclaims any and all liability for any damages or losses incurred by you or any third parties arising from the use of any Renesas Electronics product that is inconsistent with any Renesas Electronics data sheet, user's manual or other Renesas Electronics document.
6. When using Renesas Electronics products, refer to the latest product information (data sheets, user's manuals, application notes, "General Notes for Handling and Using Semiconductor Devices" in the reliability handbook, etc.), and ensure that usage conditions are within the ranges specified by Renesas Electronics with respect to maximum ratings, operating power supply voltage range, heat dissipation characteristics, installation, etc. Renesas Electronics disclaims any and all liability for any malfunctions, failure or accident arising out of the use of Renesas Electronics products outside of such specified ranges.
7. Although Renesas Electronics endeavors to improve the quality and reliability of Renesas Electronics products, semiconductor products have specific characteristics, such as the occurrence of failure at a certain rate and malfunctions under certain use conditions. Unless designated as a high reliability product or a product for harsh environments in a Renesas Electronics data sheet or other Renesas Electronics document, Renesas Electronics products are not subject to radiation resistance design. You are responsible for implementing safety measures to guard against the possibility of bodily injury, injury or damage caused by fire, and/or danger to the public in the event of a failure or malfunction of Renesas Electronics products, such as safety design for hardware and software, including but not limited to redundancy, fire control and malfunction prevention, appropriate treatment for aging degradation or any other appropriate measures. Because the evaluation of microcomputer software alone is very difficult and impractical, you are responsible for evaluating the safety of the final products or systems manufactured by you.
8. Please contact a Renesas Electronics sales office for details as to environmental matters such as the environmental compatibility of each Renesas Electronics product. You are responsible for carefully and sufficiently investigating applicable laws and regulations that regulate the inclusion or use of controlled substances, including without limitation, the EU RoHS Directive, and using Renesas Electronics products in compliance with all these applicable laws and regulations. Renesas Electronics disclaims any and all liability for damages or losses occurring as a result of your noncompliance with applicable laws and regulations.
9. Renesas Electronics products and technologies shall not be used for or incorporated into any products or systems whose manufacture, use, or sale is prohibited under any applicable domestic or foreign laws or regulations. You shall comply with any applicable export control laws and regulations promulgated and administered by the governments of any countries asserting jurisdiction over the parties or transactions.
10. It is the responsibility of the buyer or distributor of Renesas Electronics products, or any other party who distributes, disposes of, or otherwise sells or transfers the product to a third party, to notify such third party in advance of the contents and conditions set forth in this document.
11. This document shall not be reprinted, reproduced or duplicated in any form, in whole or in part, without prior written consent of Renesas Electronics.
12. Please contact a Renesas Electronics sales office if you have any questions regarding the information contained in this document or Renesas Electronics products.

(Note1) "Renesas Electronics" as used in this document means Renesas Electronics Corporation and also includes its directly or indirectly controlled subsidiaries.

(Note2) "Renesas Electronics product(s)" means any product developed or manufactured by or for Renesas Electronics.

(Rev.4.0-1 November 2017)

Corporate Headquarters

TOYOSU FORESIA, 3-2-24 Toyosu,
Koto-ku, Tokyo 135-0061, Japan
www.renesas.com

Trademarks

Renesas and the Renesas logo are trademarks of Renesas Electronics Corporation. All trademarks and registered trademarks are the property of their respective owners.

Contact information

For further information on a product, technology, the most up-to-date version of a document, or your nearest sales office, please visit:
www.renesas.com/contact/.