

ISL91134IIQ-EVZ

Evaluation Board

AN1957  
Rev 0.00  
September 5, 2014

**Description**

The ISL91134 is an integrated boost with bypass switching regulator for battery powered applications. The device provides a power supply solution for products using one cell Li-ion or Li-polymer battery. The device is capable of delivering up to 1.8A output current from  $V_{IN} = 3V$  and  $V_{OUT} = 5V$ . The no-load quiescent current is only 108µA in boost mode and 45µA in forced bypass mode, which significantly reduces the standby consumption. The ISL91134 evaluation board allows quick evaluation of the high performance features of this regulator.

**Specifications**

The boards are designed to operate at the following operating conditions:

- Input voltage rating from 2.35V to 5.4V
- Output current: up to 1.8A ( $V_{IN} = 3V$ ,  $V_{OUT} = 5V$ )
- Forced bypass or auto bypass modes with a 38mΩ switch
- PFM mode at light-load currents
- 108µA quiescent current minimizes standby consumption in boost mode
- 2.5MHz switching frequency

**Key Board Features**

- Jumper selectable EN (Enabled/Disabled)
- Jumper selectable  $\overline{BYP}$  (Auto/Forced)
- Jumper selectable VSET (No offset/offset on  $V_{OUT}$ )
- Connectors, test points, and jumpers for easy probing

**References**

- [ISL91134](#) Datasheet

**Ordering Information**

EVALUATION BOARD NUMBER	$V_{OUT}$ OPTION
ISL91134IIQ-EVZ	5.0/5.2V (VSET L/H)

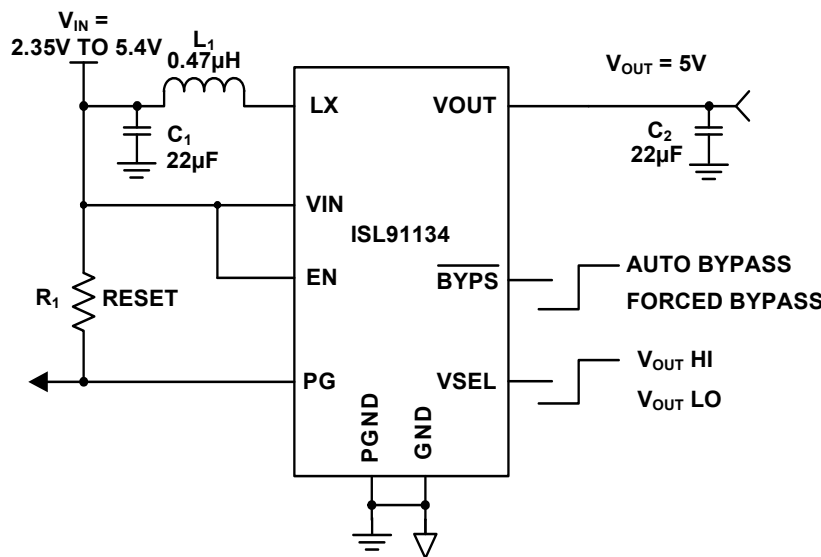

FIGURE 1. ISL91134 TYPICAL APPLICATION SCHEMATIC

## Functional Description

The ISL91134 implements a complete boost switching regulator, with PWM controller, internal switches, references, protection circuitry and bypass control. The ISL91134 is designed to support 5V output voltage. A voltage select pin (VSET) is available to scale up the output voltage by a small offset to compensate the load transient droop. The evaluation boards have been functionally optimized for best performance of the ISL91134. This part requires only an inductor and a few external components to operate. The 2.5MHz switching frequency further reduces the size of external components. The input power and load connections are provided through multi pin connectors for high current operations.

The ISL91134 evaluation board is shown in [Figures 3 and 4](#). The board's enable function is controlled by the on-board jumper header J3. Similarly, the VSET function is controlled by the on-board jumper header J4 and the BYPASS function can be set to Forced or Auto mode by controlling the on-board jumper header J5.

The schematic of the ISL91134-EVZ evaluation board is shown on [page 4](#). The PCB layout images for all layers are shown in [Figures 5 and 6](#). The bill of materials of the ISL91134-EVZ is shown in [Table 1](#).

## Operating Range

The  $V_{IN}$  range of the boards is 2.35V to 5.4V. The  $V_{OUT}$  for the ISL91134 is 5V. The  $I_{OUT}$  range of the boards is 0 to 2A. The operating ambient temperature range is  $-40^{\circ}\text{C}$  to  $+85^{\circ}\text{C}$ .

## Quick Start Guide

For the ISL91134 board, the voltage can be set to 5V with  $VSET = 0$  and 5.2V with  $VSET = 1$ .

Refer to the following Quick Setup Guide to configure and power-up the board for proper operation. During the power-on process, the expected waveforms are shown in [Figure 2](#).

## Quick Setup Guide

1. Install jumpers on J3 shorting EN to VIN.
2. Install jumper on J5 shorting  $\overline{\text{BYPSS}}$  to VIN, auto bypass mode.
3. Install jumper on J4 shorting VSET to GND or leave it as NC.
4. Connect power supply to J1, with voltage setting between 2.35V and 5.4V.
5. Connect electronic load to J2.
6. Place scope probes on VOUT test point, and other test points of interest.
7. Turn on the power supply.
8. Monitor the output voltage  $V_{OUT} = 5.05\text{V}$  when  $V_{IN} < 5\text{V}$  (Boost mode),  $V_{IN} = V_{OUT}$  when  $V_{IN} > 5.15$  (bypass mode), the supply current should be  $\sim 110\mu\text{A}$  (boost mode) and  $\sim 95\mu\text{A}$  in (auto bypass mode). In forced bypass ( $\overline{\text{BYPSS}}$  pin = GND), supply current should be  $\sim 45\mu\text{A}$ .
9. Turn on the electronic load.
10. Measure the output voltage with the voltmeter. The voltage should regulate within data sheet spec limits.
11. To determine efficiency, measure input and output voltages at the test points J1 and TP3. The bench power supply can be

connected to the PVIN and GND headers on J1. The electronic load can be connected to the  $V_{OUT}$  and GND headers on J2 measure the input and output currents. Calculate efficiency based on these measurements.

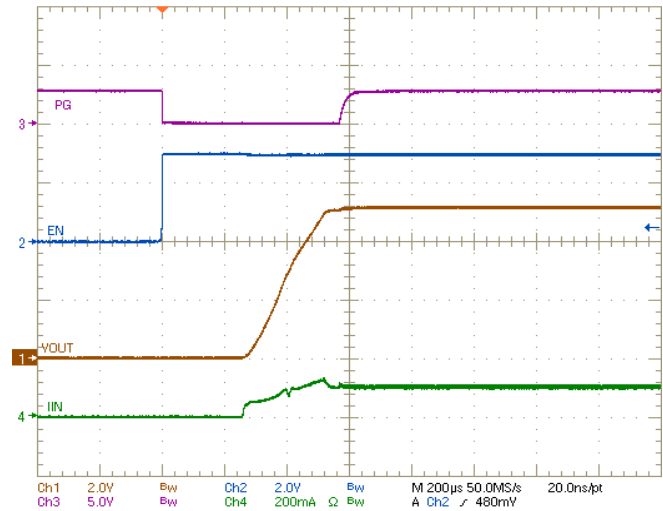

FIGURE 2. START-UP WAVEFORM 50Ω LOAD

## Layout Considerations

1.  $C_1$  is used to compensate for line drops on cables from power supply to the IC, this will not be required for the actual board design.
2. The Input capacitor ( $C_2$ ) should be placed close to the IC to reduce  $V_{IN}$  spikes/noise.
3. Output capacitors ( $C_3$ ,  $C_4$ ) should be placed as close as possible to the IC to minimize  $V_{OUT}$  spikes.
4. Boost Inductor ( $L_1$ ) between VIN and LX should be connected using short and wide traces. It is recommended to use multiple vias between the LX pin and the inductor. Three vias of 7mils width were used on the evaluation board.
5. Recommend maximizing copper pour area for VIN, VOUT and GND for better thermal performance.
6. AGND and PGND of the IC should be connected to each other. It is crucial to connect these two grounds at a location very close to the IC.

# ISL91134 Evaluation Board

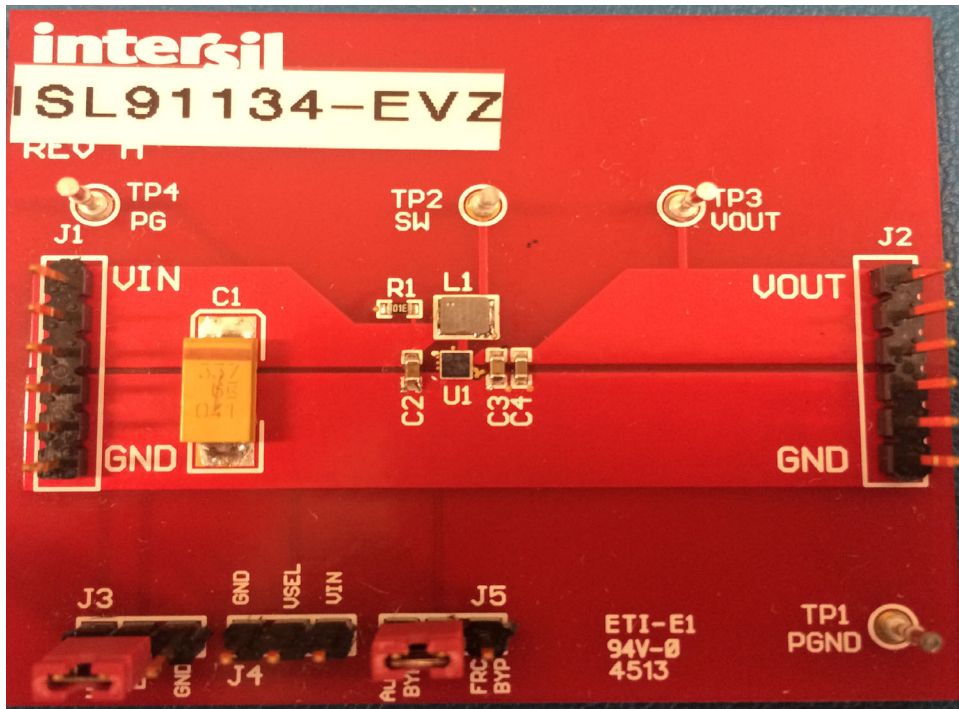

FIGURE 3. TOP VIEW

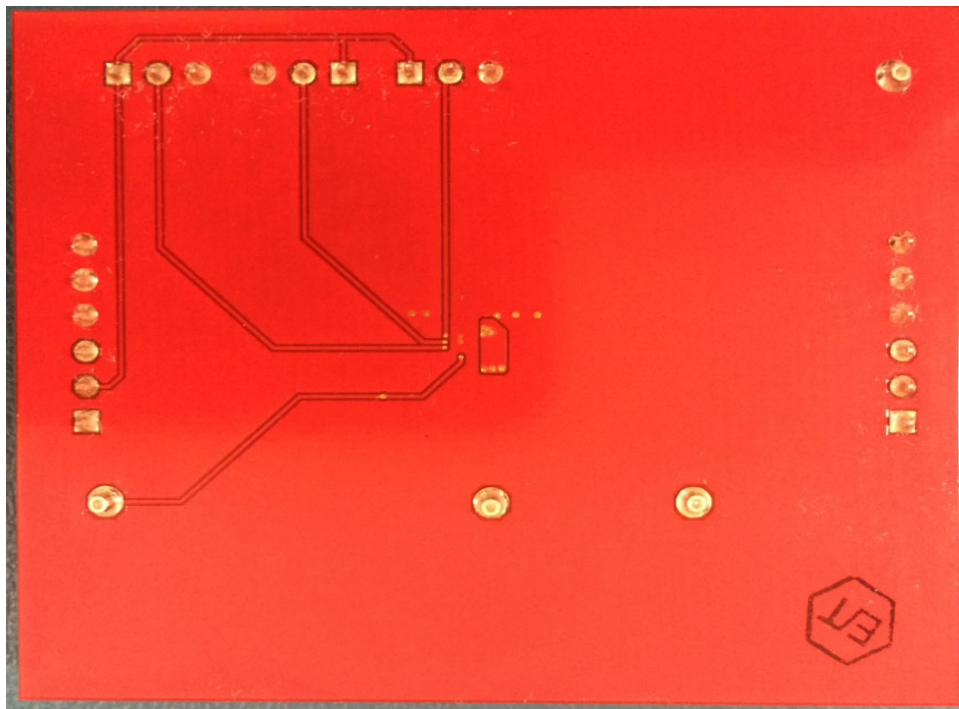

FIGURE 4. BOTTOM VIEW

# ISL91134 Evaluation Board Schematic

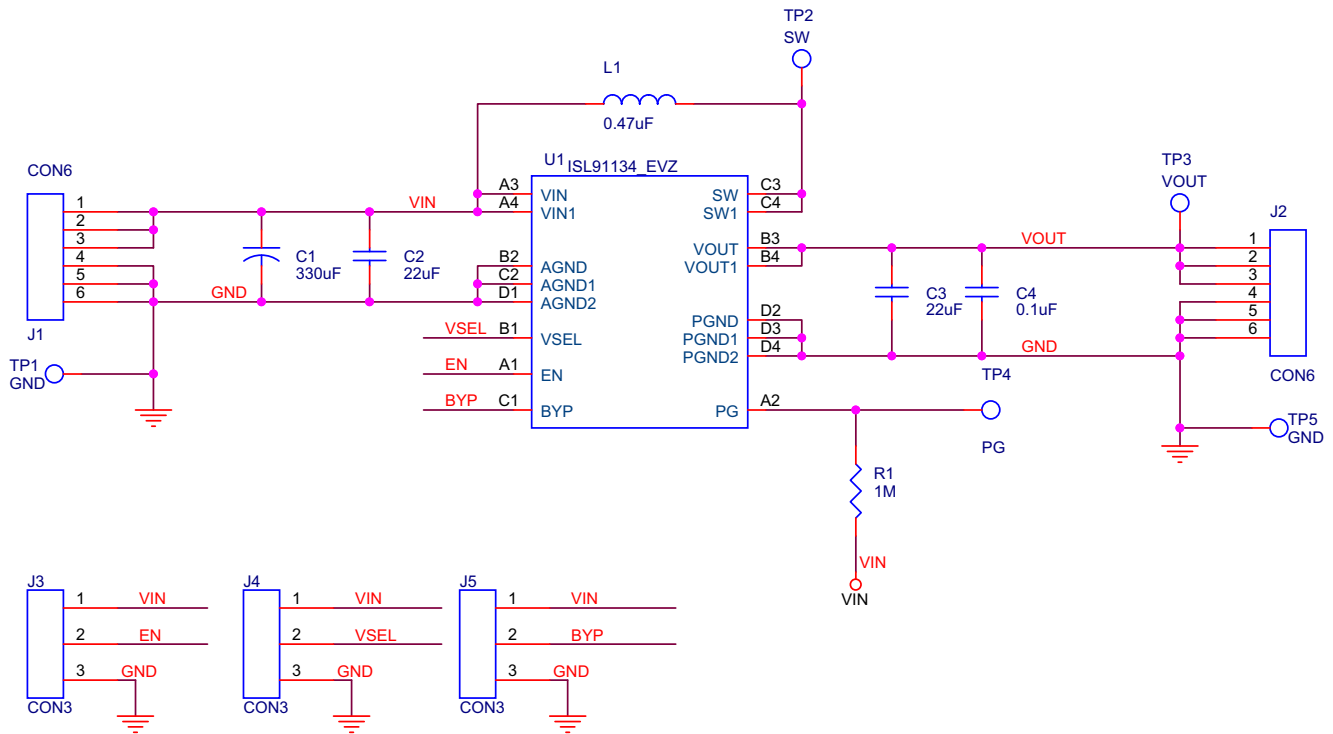

TABLE 1. ISL91134 EVALUATION BOARD BILL OF MATERIALS

ITEM#	QTY	DESIGNATORS	PART TYPE	FOOTPRINT	DESCRIPTION	VENDORS
1	1	U1	ISL91134	W4x4.16E WLCSP	Intersil ISL91134 Boost with Bypass Regulator	INTERSIL
2	1	L1	0.47µH	3.2x2.5mm	PIFE32251B-R47MS-39	Cyntec
3	1	C1	330µF/6.3V/X5R	7343	T491D337K006AT	Kemet
4	2	C2, C3	22µF/6.3V/X5R	0603	GRM188R61A226M	ANY
5	1	C4	0.1µF	0603	GRM188R71H104KA93D	ANY
6	1	R1	1MΩ, 1%	0603	Resistor, Generic	ANY
7	2	J1, J2	HDR-6	HDR-6	Vert. Pin Header, 6-Pin, 0.1" Spacing, Generic	FCI
8	3	J3, J4, J5	HDR-3	HDR-3	Vert. Pin Header, 3-Pin, 0.1" Spacing, Generic	FCI
9	4	TP1, TP2, TP3, TP4	TEST POINT	TEST POINT	Test Point, 1514-2	KEYSTONE

# PCB Layout

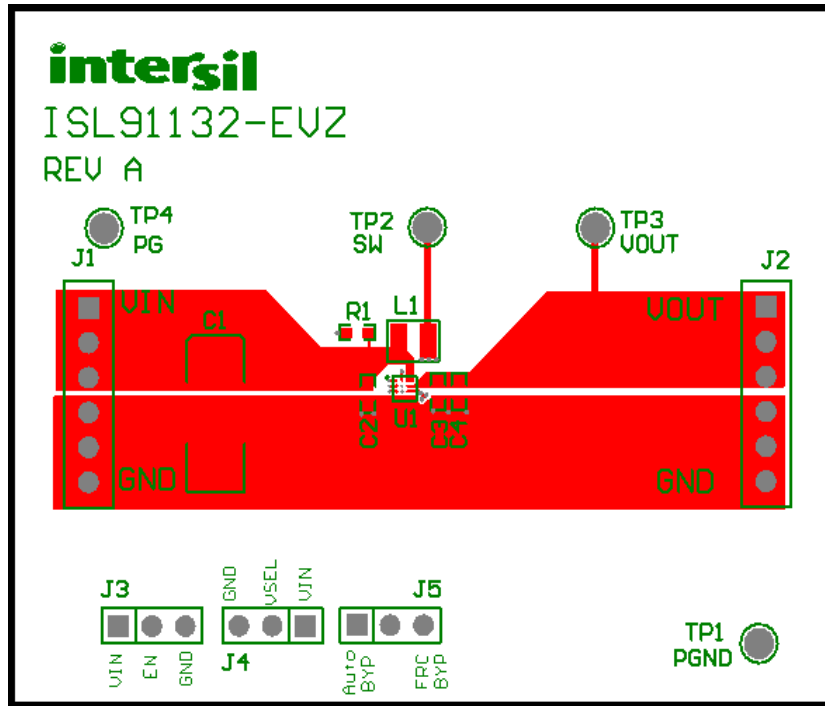

FIGURE 5. TOP LAYER (RECOMMEND USING ISL91132 LAYOUT PLAN FOR ISL91134)

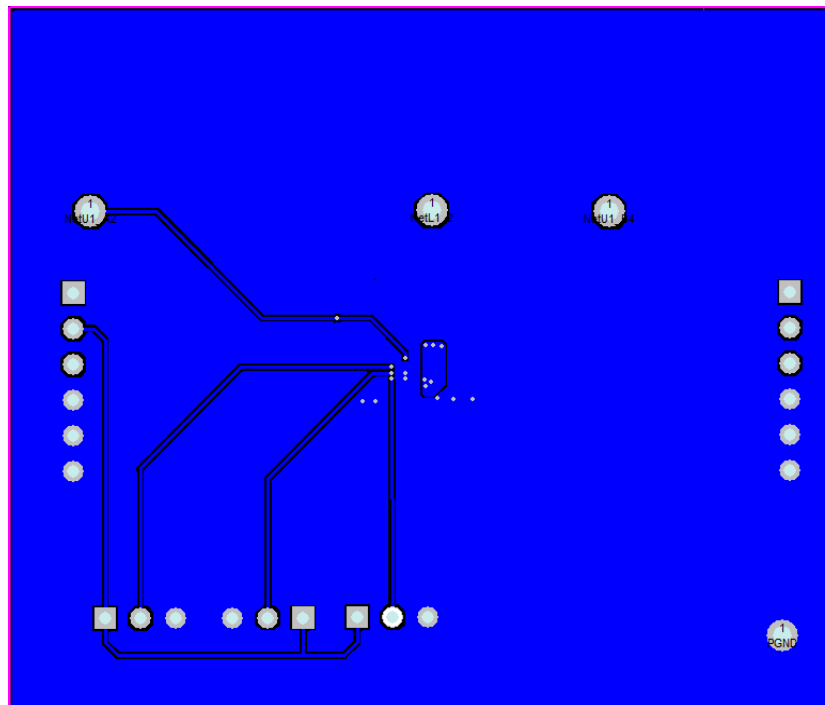

FIGURE 6. BOTTOM LAYER

# Typical Performance Curves

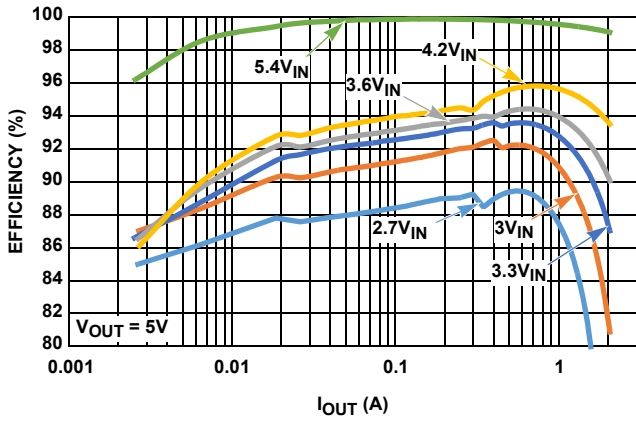

FIGURE 7. EFFICIENCY vs LOAD CURRENT,  $V_{OUT} = 5V$

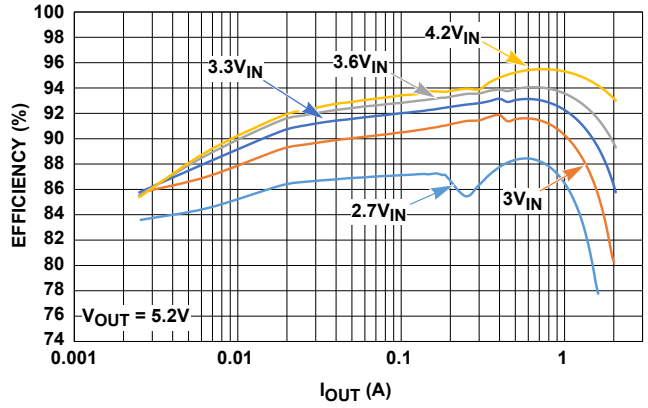

FIGURE 8. EFFICIENCY vs LOAD CURRENT,  $V_{OUT} = 5.2V$

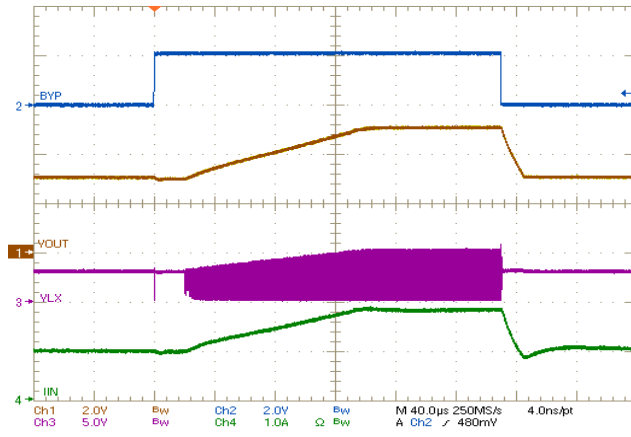

FIGURE 9. FORCED BYPASS TO BOOST TRANSITION, 1A LOAD,  $V_{IN} = 3V$

## IMPORTANT NOTICE AND DISCLAIMER

RENESAS ELECTRONICS CORPORATION AND ITS SUBSIDIARIES (“RENESAS”) PROVIDES TECHNICAL SPECIFICATIONS AND RELIABILITY DATA (INCLUDING DATASHEETS), DESIGN RESOURCES (INCLUDING REFERENCE DESIGNS), APPLICATION OR OTHER DESIGN ADVICE, WEB TOOLS, SAFETY INFORMATION, AND OTHER RESOURCES “AS IS” AND WITH ALL FAULTS, AND DISCLAIMS ALL WARRANTIES, EXPRESS OR IMPLIED, INCLUDING, WITHOUT LIMITATION, ANY IMPLIED WARRANTIES OF MERCHANTABILITY, FITNESS FOR A PARTICULAR PURPOSE, OR NON-INFRINGEMENT OF THIRD PARTY INTELLECTUAL PROPERTY RIGHTS.

These resources are intended for developers skilled in the art designing with Renesas products. You are solely responsible for (1) selecting the appropriate products for your application, (2) designing, validating, and testing your application, and (3) ensuring your application meets applicable standards, and any other safety, security, or other requirements. These resources are subject to change without notice. Renesas grants you permission to use these resources only for development of an application that uses Renesas products. Other reproduction or use of these resources is strictly prohibited. No license is granted to any other Renesas intellectual property or to any third party intellectual property. Renesas disclaims responsibility for, and you will fully indemnify Renesas and its representatives against, any claims, damages, costs, losses, or liabilities arising out of your use of these resources. Renesas' products are provided only subject to Renesas' Terms and Conditions of Sale or other applicable terms agreed to in writing. No use of any Renesas resources expands or otherwise alters any applicable warranties or warranty disclaimers for these products.

(Rev.1.0 Mar 2020)

### Corporate Headquarters

TOYOSU FORESIA, 3-2-24 Toyosu,  
Koto-ku, Tokyo 135-0061, Japan  
[www.renesas.com](http://www.renesas.com)

### Contact Information

For further information on a product, technology, the most up-to-date version of a document, or your nearest sales office, please visit:  
[www.renesas.com/contact/](http://www.renesas.com/contact/)

### Trademarks

Renesas and the Renesas logo are trademarks of Renesas Electronics Corporation. All trademarks and registered trademarks are the property of their respective owners.