

DA14583 Reference Design

Design Name	DA14583ATDB-P_VA
Ref. Number	285-03-A
Version	A00
Date	Mar, 03, 2015
Designer	K.L/N.T.

History Table		
Version	Date	Comments
A00	03 /Mar / 2015	Initial Schematic

Configuration note

NOTE box

Changes in this Version.



Dialog Semiconductor
52-54 Kalabriton Str.
26335, Patra, Greece
tel. (+30) 2610390940
fax. (+30) 2610390941

Title : **DA14583UNDB-P**

Doc. Nr.	285-03-A	Designer: Liantinioti Kalliopi/N.T.	Rev: A
Date:	Thursday, March 05, 2015		Sheet: 1 of 2

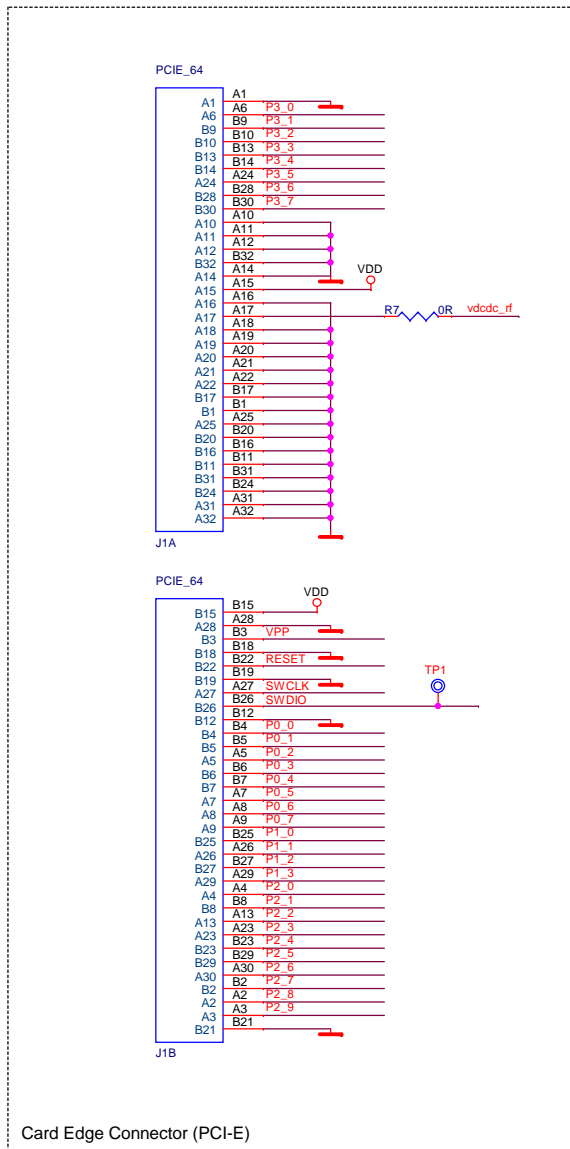

PORT PIN	SPI FLASH
P2_0	SPI_CLK
P2_3	SPI_EN
P2_4	SPI_DO
P2_9	SPI_DI

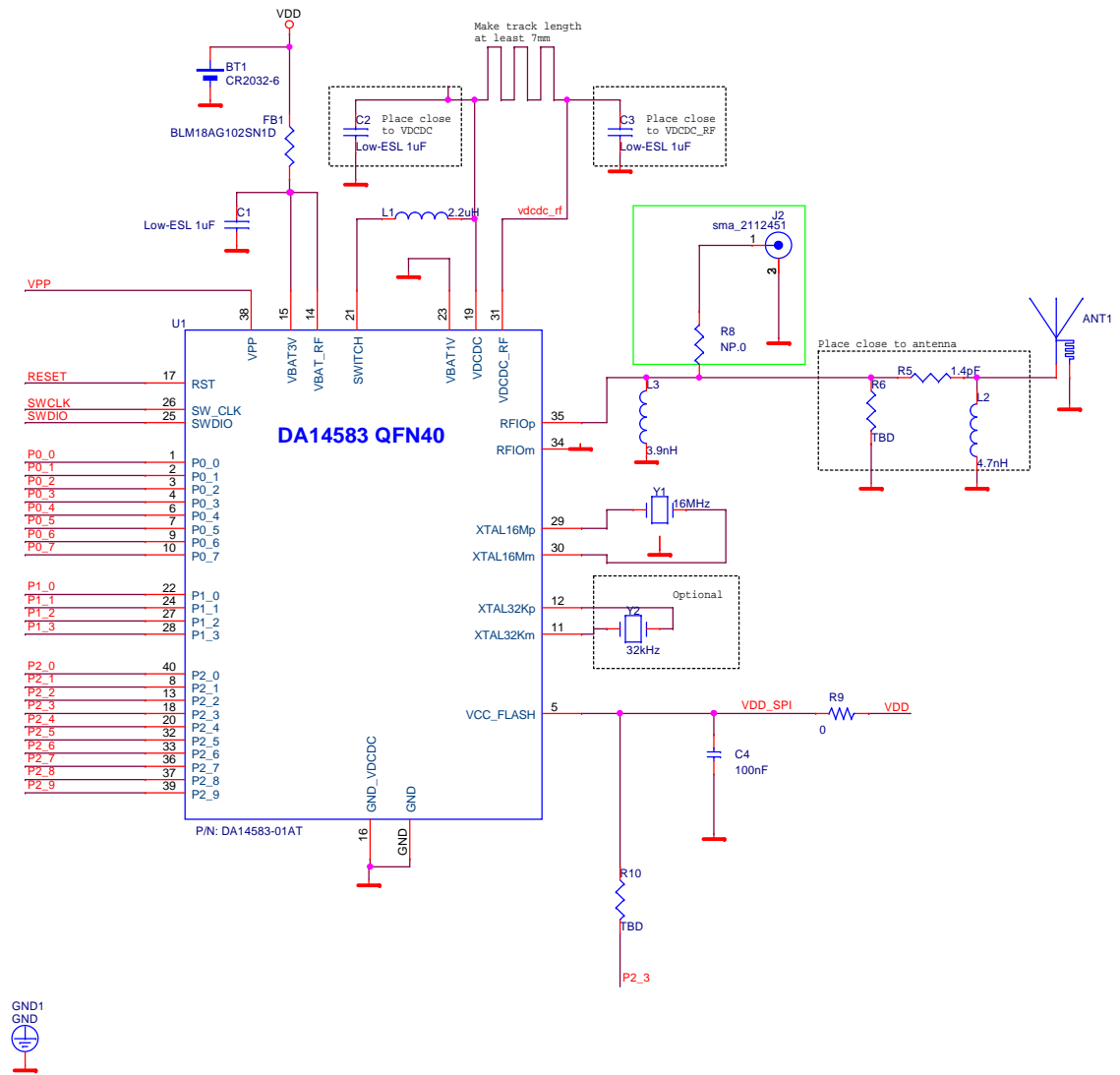

NOTICE: To ensure proper functionality it is recommended to disable the SPI Flash located at the PRO motherboard as it might conflict with the built in SPI Flash inside the DA14583