

iW7038

16-Channel Internal Current Sink LED Backlighting Driver for HDR LCD TV/Monitor/Notebook Displays

The **iW7038** is a 16-channel, internal current sink, high precision, LED backlighting driver for high dynamic range (HDR) LCD TVs, monitors and notebook displays.

It combines adaptive DC/DC or AC/DC feedback control together with Dialog's patented **BroadLED™** digital adaptive switch mode technology to enable the best system efficiency and thermal performance.

The iW7038 also offers Dialog's **AnyMode™** comprehensive dimming control, which includes head/tail/center mode PWM alignments to reduce motion blur. Additionally, it supports 13-bit PWM dimming and 11-bit analog dimming to improve contrast ratio in HDR applications.

Full protections are included, including built-in LED open/short detection and protection during both start-up and normal operation.

Features

- 16 channel LED driver
- Internal current sink MOSFETs
- External current sense resistors
- Single power supply, 12V (9V to 16V range) 50V max. output voltage
- 200mA x 100% duty x 16ch output current capability, support 2 channel grouping
- 13-bit max PWM dimming
 - range from 0% to 99.9%
 - 1μs min. PWM output pulse
 - Programmable output slew rate for EMI control (0.35μs/0.70μs/1μs)
- Enhanced pure digital **BroadLED™** mode
- 11-bit global or 9-bit independent analog dimming
- LED current and PWM duty update both
- 46Hz to 32kHz VSYNC input, 46Hz to 32KHz PWM output
- Adaptive external DC/DC or AC/DC feedback control to optimize system power efficiency
- PWM-generator clock
 - HSYNC (up to 22MHz)
 - PLL (20MHz)
 - Internal OSC (10MHz)
- 16MHz Max SPI with Daisy chain
- Optional Key registers write protection with password, and optional data packet CRC/checksum for noisy SPI interface
Programmable LED open/short detection threshold and protection
- High temperature shutdown and auto recovery
- Fault interrupt output (open drain, need external pull up)
- HBM +/- 2kV JESD22-A114 -20 at all pins
- -20 to +85°C operating ambient temperature range
- 145°C max. operating junction temperature
- Package: 7mm x 7mm QFN48 with EP, 0.5mm pin pitch synchronized to VSYNC

Applications

- HDR LCD TV
- HDR LCD Monitor
- HDR NB display
- Automobile Display

1. Overview

1.1 System Diagram

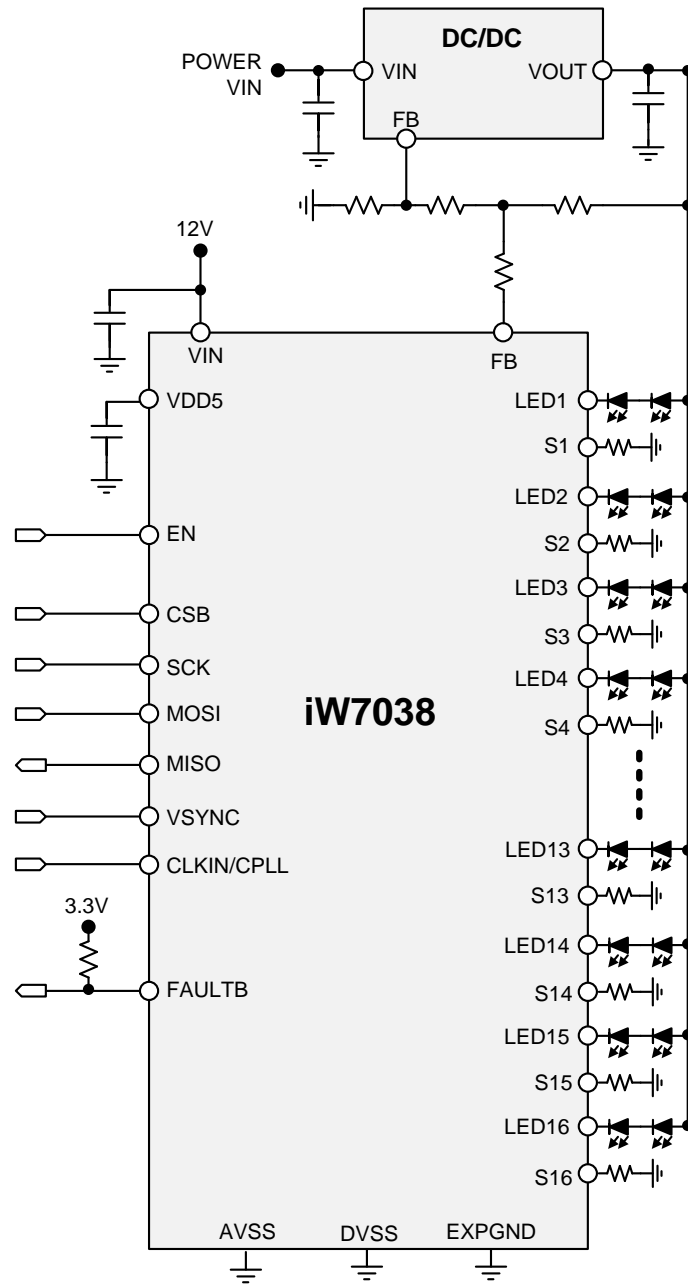

Figure 1. System Diagram

2. Pin Information

2.1 Pin Assignments

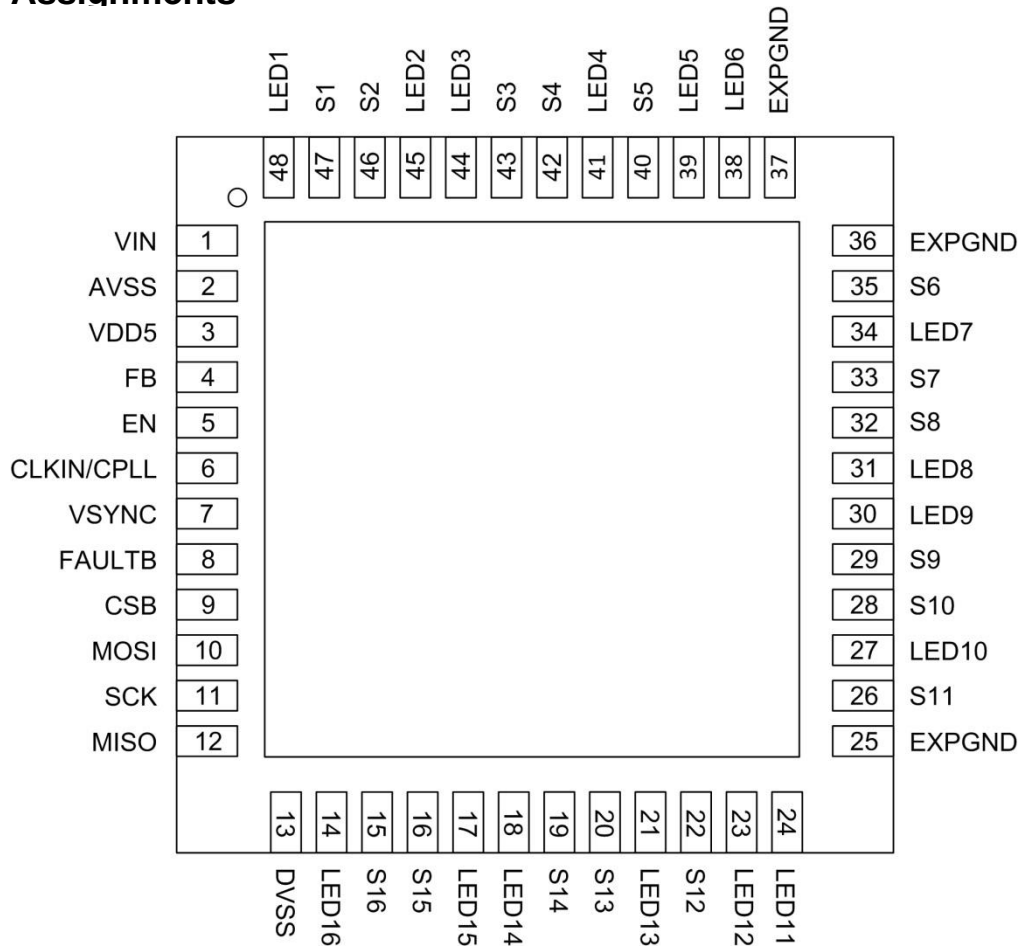

Figure 2. Pin Assignments – Top View

2.2 Pin Descriptions

Pin Number	Pin Name	Type	Description
1	VIN	AI	Power supply. Connect 4.7 μ F capacitor to AVSS.
2	AVSS	GND	GND.
3	VDD5	AIO	5V LDO compensation Pin. Need a \geq 4.7 μ F ceramic cap for decoupling. Recommended ESR range of 50m Ω to 350m Ω .
4	FB	AIO	Analog DAC output interface with external AC/DC or DC/DC converter for LED strings.
5	EN	DI	Chip enable.
6	CLKIN/CPLL	DI/AI	PLL compensation input/External clock in.
7	VSYNC	DI	VSYNC clock input in SPI dimming mode
8	FAULTB	DO	Fault status (Active Low) - Open drain.

iW7038 Product Summary

Pin Number	Pin Name	Type	Description
9	CSB	DI	chip select input for SPI slave. Active LOW.
10	MOSI	DI	Master output, slave input for SPI.
11	SCK	DI	Serial clock input for SPI.
12	MISO	DO	Master input, slave output for SPI.
13	DVSS	GND	GND.
14	LED16	AI	LED cathode connection for string 16.
15	S16	AO	Source of internal MOSFET, connect to sense resistor.
16	S15	AO	Source of internal MOSFET, connect to sense resistor.
17	LED15	AI	LED cathode connection for string 15.
18	LED14	AI	LED cathode connection for string 14.
19	S14	AO	Source of internal MOSFET, connect to sense resistor.
20	S13	AO	Source of internal MOSFET, connect to sense resistor.
21	LED13	AI	LED cathode connection for string 13.
22	S12	AO	Source of internal MOSFET, connect to sense resistor.
23	LED12	AI	LED cathode connection for string 12.
24	LED11	AI	LED cathode connection for string 11.
25	EXPGND	GND	Exposed PAD for LED driver, connect to GND.
26	S11	AO	Source of internal MOSFET, connect to sense resistor.
27	LED10	AI	LED cathode connection for string 10.
28	S10	AO	Source of internal MOSFET, connect to sense resistor.
29	S9	AO	Source of internal MOSFET, connect to sense resistor
30	LED9	AI	LED cathode connection for string 9.
31	LED8	AI	LED cathode connection for string 8.
32	S8	AO	Source of internal MOSFET, connect to sense resistor.
33	S7	AO	Source of internal MOSFET, connect to sense resistor.
34	LED7	AI	LED cathode connection for string 7.
35	S6	AO	Source of internal MOSFET, connect to sense resistor.
36	EXPGND	GND	Exposed PAD for LED driver, connect to GND.
37	EXPGND	GND	Exposed PAD for LED driver, connect to GND.
38	LED6	AI	LED cathode connection for string 6.
39	LED5	AI	LED cathode connection for string 5.

iW7038 Product Summary

Pin Number	Pin Name	Type	Description
40	S5	AO	Source of internal MOSFET, connect to sense resistor.
41	LED4	AI	LED cathode connection for string 4.
42	S4	AO	Source of internal MOSFET, connect to sense resistor.
43	S3	AO	Source of internal MOSFET, connect to sense resistor.
44	LED3	AI	LED cathode connection for string 3.
45	LED2	AI	LED cathode connection for string 2.
46	S2	AO	Source of internal MOSFET, connect to sense resistor.
47	S1	AO	Source of internal MOSFET, connect to sense resistor.
48	LED1	AI	LED cathode connection for string 1.

A_I/O: Analog pin

P: Power pin

DO: Digital Output

DO_OD: Digital Output Open Drain

DI: Digital Input

DI_PU: Digital Input with Pull Up resistor

DI_PD: Digital Input with Pull Down resistor

3. Specifications

3.1 Absolute Maximum Ratings

Caution: Do not operate at or near the maximum ratings listed for extended periods of time. Exposure to such conditions can adversely impact product reliability and result in failures not covered by warranty.

Parameter	Symbol	Minimum	Maximum	Unit
VIN supply voltage	VIN	-0.3	20	V
5V LDO output	VDD5	-0.3	7	V
Ground pins	GND pins (AVSS, DVSS, EXPGND)	-0.3	0.3	V
LEDn pin voltage	LEDn (LED1~LED16)	-0.3	50	V
Internal MOSFET source pins	Sn(S1~S16)	-0.3	7	V
Digital logic I/O pins and voltage feedback pins	Other low voltage pins (CSB, SCK, MISO, MOSI, VSYNC, CLKIN/CPLL, EN, FAULTB, FB)	-0.3	7	V
Junction Temperature	T _{JMAX}	-40	+150	°C
Storage Temperature Range	T _{ST}	-40	+150	°C
Human Body Model (Tested per JS-001-2017)	V _{ESDHBM}	-2000	+2000	V
Latch-Up (Tested per JESD78E; Class 2, Level A)	I _{SCR}	-100	+100	mA

3.2 Thermal Specifications

Parameter	Package	Symbol	Condition	Typical Value	Unit
Thermal Resistance	48-QFN, 7mm x 7mm	θ_{JA}	Junction to ambient	TBD	°C/W
		θ_{JC}	Junction to case	TBD	

4. Package Outline Drawings

The package outline drawings are located at the end of this document and are accessible from the Renesas website. The package information is the most current data available and is subject to change without revision of this document.

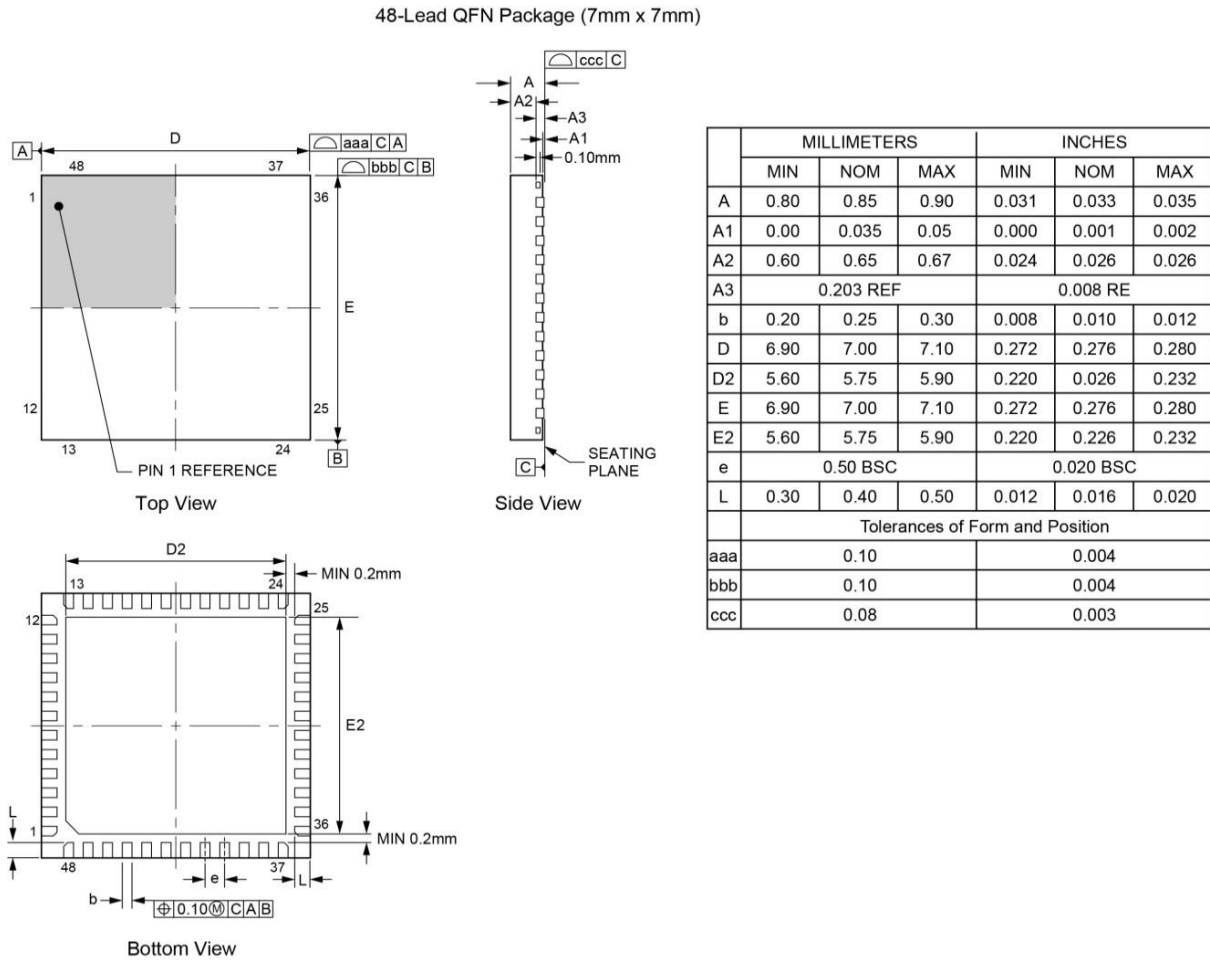

Controlling dimensions are in millimeters; inch dimensions are for reference only.

Package warpage max. 0.08mm.

Package is IPC/JEDEC Std 020D Moisture Sensitivity Level 3.

This product is RoHS compliant and Halide free.

Compliant to JEDEC Standard MO-220.

Figure 3: 48-Lead 7mm x 7mm QFN Package Outline Drawing

5. Ordering Information

Part Number	Package Description	Carrier Type	Temperature Range
iW7038-00-QFN4	QFN-7mm x 7mm 48L	Tape and Reel ¹	-40°C to +150°C

1. Tape & Reel packing quantity is 4,000/reel. Minimum ordering quantity is 4,000.

IMPORTANT NOTICE AND DISCLAIMER

RENESAS ELECTRONICS CORPORATION AND ITS SUBSIDIARIES (“RENESAS”) PROVIDES TECHNICAL SPECIFICATIONS AND RELIABILITY DATA (INCLUDING DATASHEETS), DESIGN RESOURCES (INCLUDING REFERENCE DESIGNS), APPLICATION OR OTHER DESIGN ADVICE, WEB TOOLS, SAFETY INFORMATION, AND OTHER RESOURCES “AS IS” AND WITH ALL FAULTS, AND DISCLAIMS ALL WARRANTIES, EXPRESS OR IMPLIED, INCLUDING, WITHOUT LIMITATION, ANY IMPLIED WARRANTIES OF MERCHANTABILITY, FITNESS FOR A PARTICULAR PURPOSE, OR NON-INFRINGEMENT OF THIRD PARTY INTELLECTUAL PROPERTY RIGHTS.

These resources are intended for developers who are designing with Renesas products. You are solely responsible for (1) selecting the appropriate products for your application, (2) designing, validating, and testing your application, and (3) ensuring your application meets applicable standards, and any other safety, security, or other requirements. These resources are subject to change without notice. Renesas grants you permission to use these resources only to develop an application that uses Renesas products. Other reproduction or use of these resources is strictly prohibited. No license is granted to any other Renesas intellectual property or to any third-party intellectual property. Renesas disclaims responsibility for, and you will fully indemnify Renesas and its representatives against, any claims, damages, costs, losses, or liabilities arising from your use of these resources. Renesas’ products are provided only subject to Renesas’ Terms and Conditions of Sale or other applicable terms agreed to in writing. No use of any Renesas resources expands or otherwise alters any applicable warranties or warranty disclaimers for these products.

© 2024 Renesas Electronics Corporation. All rights reserved.

(Disclaimer Rev.1.01 Jan 2024)

Corporate Headquarters

TOYOSU FORESIA, 3-2-24 Toyosu
Koto-ku, Tokyo 135-0061, Japan
www.renesas.com

Contact Information

For further information on a product, technology, the most up-to-date version of a document, or your nearest sales office, please visit: www.renesas.com/contact/

Trademarks

Renesas and the Renesas logo are trademarks of Renesas Electronics Corporation. All trademarks and registered trademarks are the property of their respective owners.