

## AS3824

16-Channel White LED Controller for LCD Backlight

The **AS3824** is a 16 channel high precision LED controller for use in LCD-backlight panels. Dynamic power feedback controls the external power supply to guarantee best efficiency. One high accurate global 10 bit DAC can be used to set the LED current as well as each channel has its own additional 8 bit DAC to boost the dynamic range of LED Backlight systems.

Each channel is equipped with an independent PWM generator which can also be synchronized to an external synchronization signal (VSYNC).

A fast mode supports minimum PWM duty cycle operation which helps to further reduce the energy consumption of modern LED Backlight systems.

The PWM generator clock can be generated internally (DPLL) or an external clock source can be connected to the HSYNC input.

Built-in safety features include thermal shutdown as well as open and short LED detection. The device is programmable via serial interface (SPI).

## Features

- Supports all LED backlight topologies
- No limit of VLED or ILED, device is not exposed to high voltage/high current
- Optimum power savings through local dimming
  - 16 fully flexible 12 bit PWM generators (period, high time, delay, reverse)
- One global highly accurate 10 bit DAC which sets the LED current ( $\pm 0.5\%$  accuracy)
- High dynamic range boost function
  - 16 independent 8 bit DACs can be used to boost/decrease LED current within certain frames
- Global dimming mode option
  - AS3824E/E1 are pre-programmed as external PWM mode (DPWM mode), V<sub>SYNC</sub> pin is used as PWM input. AS3824A/A1 are pre-programmed as SPI mode
- VSYNC and HSYNC inputs, as well as integrated digital PLL for synchronization with TV frame
- Lowest BOM
  - Due to 2 pin concept of the output channel: no HV protection, no cascade FETs
- Feedback function is compatible to every DC-DC architecture and configurable via SPI
- Short/OPEN LED detection, temperature shutdown, register lock/unlock, SPI transfer checksum

## Applications

- HD TVs
- UHD TVs
- LCD Monitors

# 1. Overview

## 1.1 Typical Application

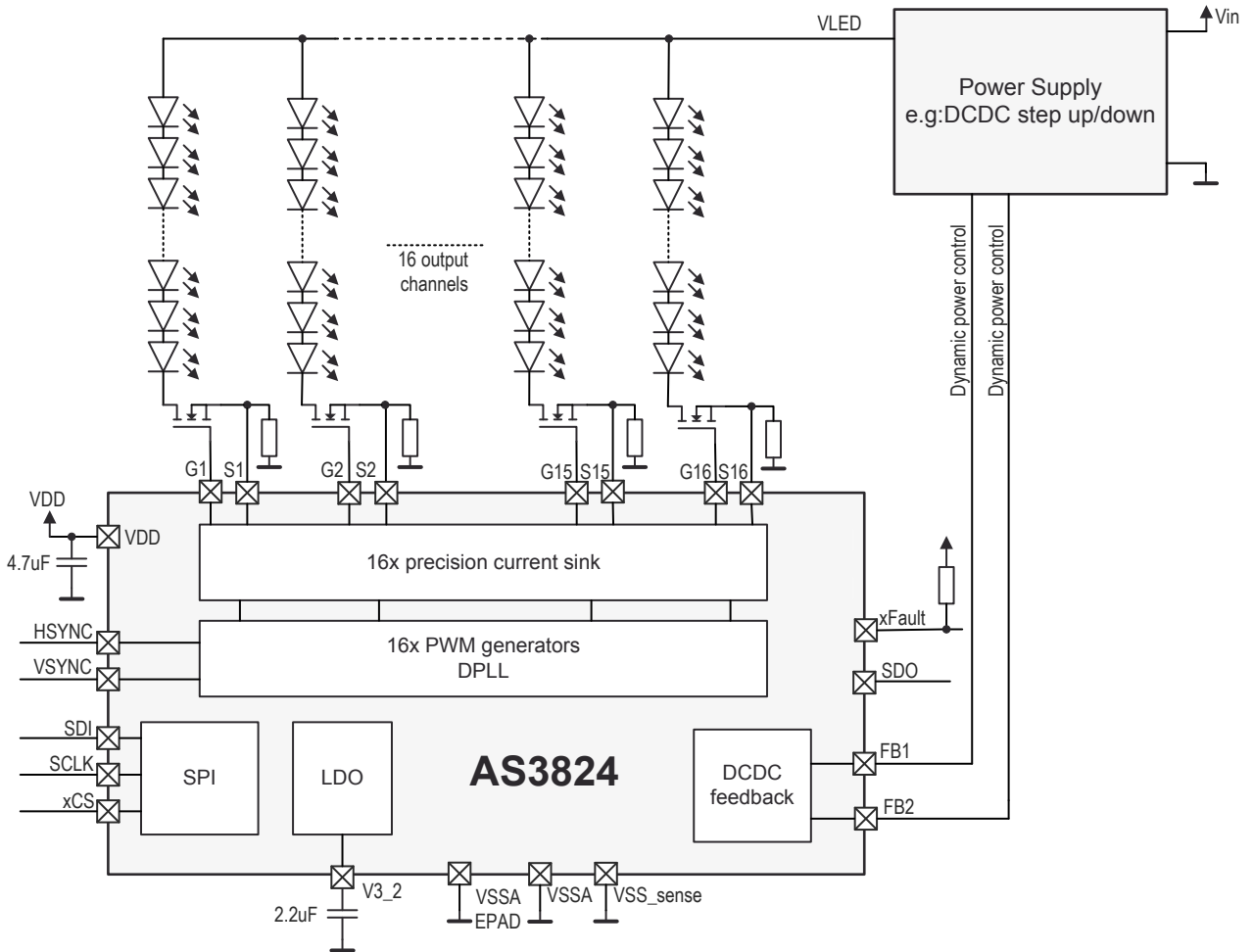

Figure 1. AS3824 Typical Application

## 2. Pin Information

### 2.1 Pin Assignments

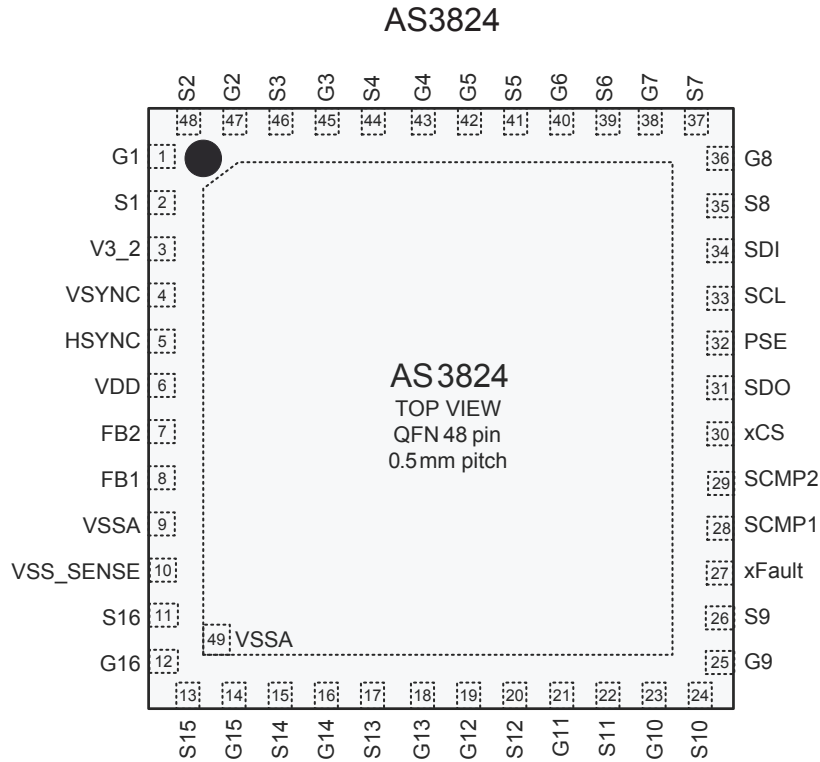

Figure 2. Top View

### 2.2 Pin Description

Pin Number	Pin Name	Type	Description	If Not Used
1	G1	A_I/O	Connect to gate of external transistor	Connect to S1
2	S1	A_I/O	Connect to source of external transistor	Connect to G1
3	V3_2	P	Digital supply output. Connect 2.2uF capacitor to GND	
4	VSYNC	DI_PD	Vertical sync frequency. PWM generator reset	Leave open
5	HSYNC	DI_PD	Clock input for PWM generators	Leave open
6	VDD	P	Supply Voltage input Connect 4.7uF bypass capacitor to GND	
7	FB2	A_I/O	Power supply feedback output 2	Leave open
8	FB1	A_I/O	Power supply feedback output 1	Leave open
9	VSSA	P	GND	
10	VSS_SENSE	P	GND	
11	S16	A_I/O	Connect to source of external transistor	Connect to G16
12	G16	A_I/O	Connect to gate of external transistor	Connect to S16
13	S15	A_I/O	Connect to source of external transistor	Connect to G15
14	G15	A_I/O	Connect to gate of external transistor	Connect to S15
15	S14	A_I/O	Connect to source of external transistor	Connect to G14
16	G14	A_I/O	Connect to gate of external transistor	Connect to S14

## AS3824 Product Summary

Pin Number	Pin Name	Type	Description	If Not Used
17	S13	A I/O	Connect to source of external transistor	Connect to G13
18	G13	A I/O	Connect to gate of external transistor	Connect to S13
19	G12	A I/O	Connect to gate of external transistor	Connect to S12
20	S12	A I/O	Connect to source of external transistor	Connect to G12
21	G11	A I/O	Connect to gate of external transistor	Connect to S11
22	S11	A I/O	Connect to source of external transistor	Connect to G11
23	G10	A I/O	Connect to gate of external transistor	Connect to S10
24	S10	A I/O	Connect to source of external transistor	Connect to G10
25	G9	A I/O	Connect to gate of external transistor	Connect to S9
26	S9	A I/O	Connect to source of external transistor	Connect to G9
27	xFAULT	DO_OD	Open drain fault output, connect pull-up to V3_2	Leave open
28	SCMP1	AI	Input of short comparator 1	Connect to VSS
29	SCMP2	AI	Input of short comparators 2	Connect to VSS
30	xCS	DI_PU	SPI interface chip select	Leave open
31	SDO	DO	SPI interface data output. Tristate output	Leave open
32	PSE	DI_PU	Phase Shift enable	Leave open
33	SCL	DI_PD	SPI interface clock	Leave open
34	SDI	DI_PD	SPI interface data input	Leave open
35	S8	A I/O	Connect to source of external transistor	Connect to G8
36	G8	A I/O	Connect to gate of external transistor	Connect to S8
37	S7	A I/O	Connect to source of external transistor	Connect to G7
38	G7	A I/O	Connect to gate of external transistor	Connect to S7
39	S6	A I/O	Connect to source of external transistor	Connect to G6
40	G6	A I/O	Connect to gate of external transistor	Connect to S6
41	S5	A I/O	Connect to source of external transistor	Connect to G5
42	G5	A I/O	Connect to gate of external transistor	Connect to S5
43	G4	A I/O	Connect to gate of external transistor	Connect to S4
44	S4	A I/O	Connect to source of external transistor	Connect to G4
45	G3	A I/O	Connect to gate of external transistor	Connect to S3
46	S3	A I/O	Connect to source of external transistor	Connect to G3
47	G2	A I/O	Connect to gate of external transistor	Connect to S2
48	S2	A I/O	Connect to source of external transistor	Connect to G2
EP	VSSA	P	Exposed PAD. Connect to VSSP	

**A\_I/O:** Analog pin

**P:** Power pin

**DO:** Digital Output

**DO\_OD:** Digital Output Open Drain

**DI:** Digital Input

**DI\_PU:** Digital Input with Pull Up resistor

**DI\_PD:** Digital Input with Pull Down resistor

### 3. Specifications

#### 3.1 Absolute Maximum Ratings

**CAUTION:** Do not operate at or near the maximum ratings listed for extended periods of time. Exposure to such conditions can adversely impact product reliability and result in failures not covered by warranty.

Parameter	Symbol	Comments	Min	Max	Unit
Supply Voltage to Ground	$V_{DDMAX} / V_{GND}$	Applicable for pin VDD	-0.3	7	V
Maximum Voltage Analog pins	$V_{ANAMAX}$	Applicable for pins: FB1, FB2, G1-G16, S1-S16, VSYNC, HSYNC	-0.3	7	V
Maximum Voltage Digital pins	$V_{DIGMAX}$	Applicable for pins: V3_2, SDI, SDO, SCL, xCS, SCMP1, SCMP2, xFAULT, PSE	-0.3	5	V

#### 3.2 ESD Ratings

ESD Model/Test	Symbol	Rating	Unit
Human Body Model (Tested per JS-001-2017)	ESD <sub>HBM</sub>	±2000	V
CDM (Tested per JESD78E)	ESD <sub>CDM</sub>	±500	V
MM (Tested per JESD78E)	ESD <sub>MM</sub>	±200	V
Latch-Up (Tested per JESD78E; Class 2, Level A)	$I_{SCR}$	±100	mA

#### 3.3 Recommended Operating Conditions

Parameter	Symbol	Comments	Min	Max	Unit
Package Body Temperature	$T_{BODY}$	IPC/JEDEC J-STD-020 The reflow peak soldering temperature (body temperature) is specified according to IPC/JEDEC J-STD-020 "Moisture/Reflow Sensitivity Classification for Non-hermetic Solid State Surface Mount Devices." The lead finish for Pb-free leaded packages is "Matte Tin" (100% Sn)		260	°C
Relative Humidity (non-condensing)	RH <sub>NC</sub>		5	85	%
Moisture Sensitivity Level	MSL	Maximum floor life time of 168h		3	

#### 3.4 Thermal Specifications

Thermal Resistance (Typical)	$\theta_{JA}$ (°C/W)
QFN-32 package	35

Parameter	Symbol	Minimum	Maximum	Unit
Maximum Junction Temperature	$T_J$	-20	+115	°C
Maximum Storage Temperature Range	$T_{STRG}$	-55	+150	°C

## 4. Package Outline Drawings

The package outline drawings are located at the end of this document and are accessible from the Renesas website. The package information is the most current data available and is subject to change without revision of this document.

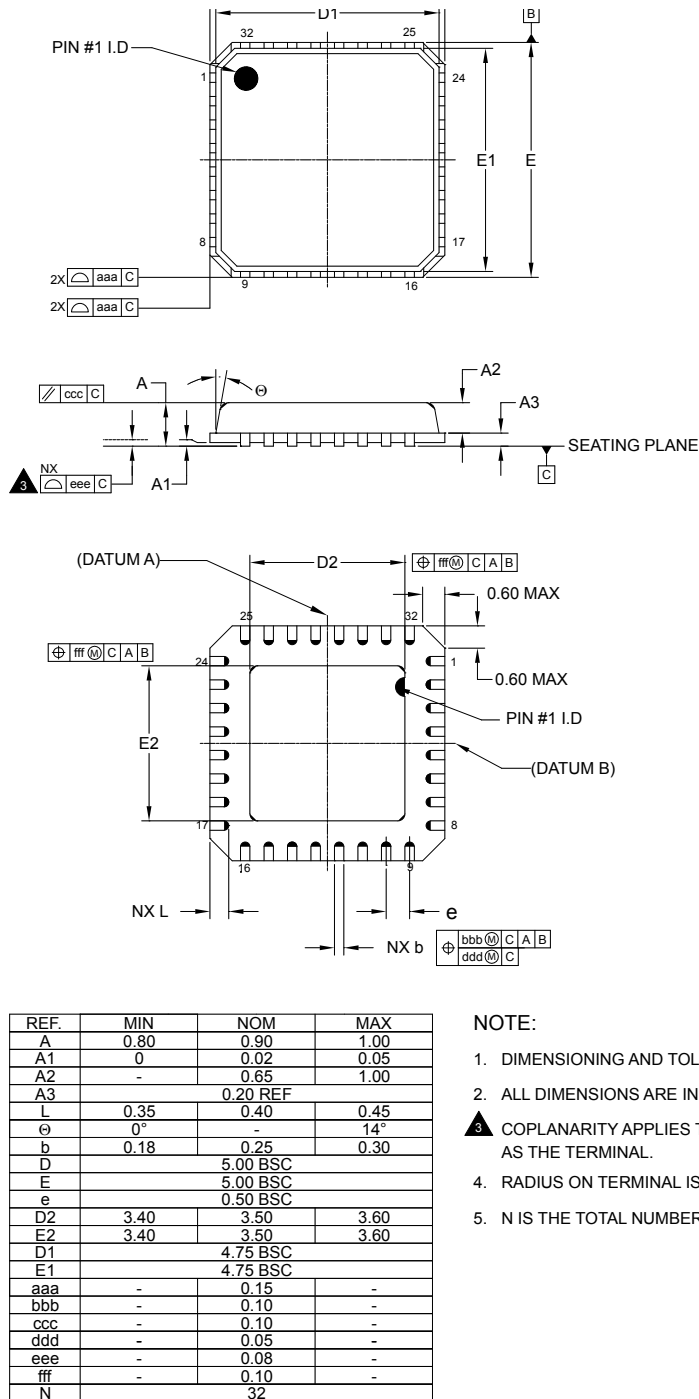

Figure 3. QFN-32 Package Outline Drawing

## 5. Ordering Information

Part Number	Ordering Code	Package	Description
AS3824A1	AS3824A1-ZQFT	48-Pin QFN	Tape & Reel <sup>1</sup>
AS3824E1	AS3824E1-ZQFT	48-Pin QFN	Tape & Reel <sup>1</sup>

1. Tape & Reel packing quantity is 4,000/reel. Minimum packing quantity is 4,000.

### IMPORTANT NOTICE AND DISCLAIMER

RENESAS ELECTRONICS CORPORATION AND ITS SUBSIDIARIES (“RENESAS”) PROVIDES TECHNICAL SPECIFICATIONS AND RELIABILITY DATA (INCLUDING DATASHEETS), DESIGN RESOURCES (INCLUDING REFERENCE DESIGNS), APPLICATION OR OTHER DESIGN ADVICE, WEB TOOLS, SAFETY INFORMATION, AND OTHER RESOURCES “AS IS” AND WITH ALL FAULTS, AND DISCLAIMS ALL WARRANTIES, EXPRESS OR IMPLIED, INCLUDING, WITHOUT LIMITATION, ANY IMPLIED WARRANTIES OF MERCHANTABILITY, FITNESS FOR A PARTICULAR PURPOSE, OR NON-INFRINGEMENT OF THIRD PARTY INTELLECTUAL PROPERTY RIGHTS.

These resources are intended for developers who are designing with Renesas products. You are solely responsible for (1) selecting the appropriate products for your application, (2) designing, validating, and testing your application, and (3) ensuring your application meets applicable standards, and any other safety, security, or other requirements. These resources are subject to change without notice. Renesas grants you permission to use these resources only to develop an application that uses Renesas products. Other reproduction or use of these resources is strictly prohibited. No license is granted to any other Renesas intellectual property or to any third-party intellectual property. Renesas disclaims responsibility for, and you will fully indemnify Renesas and its representatives against, any claims, damages, costs, losses, or liabilities arising from your use of these resources. Renesas' products are provided only subject to Renesas' Terms and Conditions of Sale or other applicable terms agreed to in writing. No use of any Renesas resources expands or otherwise alters any applicable warranties or warranty disclaimers for these products.

© 2024 Renesas Electronics Corporation. All rights reserved.

(Disclaimer Rev.1.01 Jan 2024)

### Corporate Headquarters

TOYOSU FORESIA, 3-2-24 Toyosu  
Koto-ku, Tokyo 135-0061, Japan  
[www.renesas.com](http://www.renesas.com)

### Contact Information

For further information on a product, technology, the most up-to-date version of a document, or your nearest sales office, please visit: [www.renesas.com/contact/](http://www.renesas.com/contact/)

### Trademarks

Renesas and the Renesas logo are trademarks of Renesas Electronics Corporation. All trademarks and registered trademarks are the property of their respective owners.