

## SLG46855-A

### Auto AEC-Q100 Qualified GreenPAK Programmable Mixed-Signal Matrix

#### General Description

The SLG46855-A provides a small, low power component for commonly used Mixed-Signal functions. The user creates their circuit design by programming the one time programmable (OTP) Non-Volatile Memory (NVM) to configure the interconnect logic, the IO Pins, and the macrocells of the SLG46855-A. This highly versatile device allows a wide variety of Mixed-Signal functions to be designed within a very small, low power single integrated circuit.

#### Key Features

- Two High Speed General Purpose Analog Comparators (ACMPxH)
- Two Low Power General Purpose Analog Comparators (ACMPxL)
- Two Voltage References (Vref)
  - Two Vref Outputs
- Fifteen Combination Function Macrocells
  - Three Selectable DFF/LATCH or 2-bit LUTs
  - One Selectable Programmable Pattern Generator or 2-bit LUT
  - Nine Selectable DFF/LATCH or 3-bit LUTs
  - One Selectable Pipe Delay or Ripple Counter, or 3-bit LUT
  - One Selectable DFF/LATCH or 4-bit LUTs
- Eight Multi-Function Macrocells
  - Seven Selectable DFF/LATCH or 3-bit LUTs + 8-bit Delay/Counters
  - One Selectable DFF/LATCH or 4-bit LUT + 16-bit Delay/Counter
- Serial Communications
  - I<sup>2</sup>C Protocol Interface
- Programmable Delay with Edge Detector Output
- Deglitch Filter or Edge Detector
- Three Oscillators (OSC)
  - 2.048 kHz Oscillator
  - 2.048 MHz Oscillator
  - 25 MHz Oscillator
- Analog Temperature Sensor
- Power-On Reset (POR)
- Read Back Protection (Read Lock)
- Power Supply
  - 2.5 V (±8 %) to 5 V (±10 %)
- Ambient Operating Temperature Range: -40 °C to 105 °C
- RoHS Compliant/Halogen-Free
- Available Package
  - 14-pin FCQFN: 3.0 mm x 3.0 mm x 0.55 mm, 0.65 mm pitch
- AEC-Q100 (T<sub>A</sub> = -40 °C to 105 °C) Qualified

#### Applications

- Infotainment
- Advanced Driver Assistance Systems (ADAS)
- Instrument clusters
- Audio, video, navigation

**Auto AEC-Q100 Qualified GreenPAK Programmable Mixed-Signal Matrix**
**Contents**

<b>General Description</b> .....	<b>1</b>
<b>Key Features</b> .....	<b>1</b>
<b>Applications</b> .....	<b>1</b>
<b>1 Block Diagram</b> .....	<b>7</b>
<b>2 Pinout</b> .....	<b>8</b>
2.1 Pin Configuration - FCQFN- 14L .....	8
<b>3 Characteristics</b> .....	<b>12</b>
3.1 Absolute Maximum Ratings .....	12
3.2 Electrostatic Discharge Ratings .....	12
3.3 Recommended Operating Conditions .....	12
3.4 Electrical Characteristics .....	13
3.5 I <sup>2</sup> C Pins Electrical Characteristics .....	16
3.6 Macrocells Current Consumption .....	20
3.7 Timing Characteristics .....	20
3.8 Counter/Delay Characteristics .....	24
3.9 Oscillator Characteristics .....	25
3.10 ACMP Characteristics .....	25
3.11 Analog Temperature Sensor Characteristics .....	29
<b>4 User Programmability</b> .....	<b>31</b>
<b>5 IO Pins</b> .....	<b>32</b>
5.1 GPIO Pins .....	32
5.2 GPI Pins .....	32
5.3 GPO Pins .....	32
5.4 Pull-Up/Down Resistors .....	32
5.5 Fast Pull-up/down during Power-up .....	32
5.6 GPI Structure .....	33
5.7 GPIO with I <sup>2</sup> C Mode IO Structure .....	34
5.8 Matrix OE IO Structure .....	35
5.9 GPO Structure .....	37
5.10 IO Typical Performance .....	38
<b>6 Connection Matrix</b> .....	<b>43</b>
6.1 Matrix Input Table .....	44
6.2 Matrix Output Table .....	46
6.3 Connection Matrix Virtual Inputs .....	49
6.4 Connection Matrix Virtual Outputs .....	49
<b>7 Combination Function Macrocells</b> .....	<b>50</b>
7.1 2-Bit LUT or D Flip-Flop Macrocells .....	50
7.2 2-bit LUT or Programmable Pattern Generator .....	53
7.3 3-Bit LUT or D Flip-Flop with Set/Reset Macrocells .....	55
7.4 4-Bit LUT or D Flip-Flop with Set/Reset Macrocell .....	64
7.5 3-Bit LUT or Pipe Delay/Ripple Counter Macrocell .....	66
<b>8 Multi-Function Macrocells</b> .....	<b>70</b>
8.1 3-Bit LUT or DFF/Latch with 8-Bit Counter/Delay Macrocells .....	70
8.2 4-Bit LUT or DFF/Latch with 16-Bit Counter/Delay Macrocell .....	80
8.3 CNT/DLY/FSM Timing Diagrams .....	83
8.4 Wake and Sleep Controller .....	92
<b>9 Analog Comparators</b> .....	<b>97</b>
9.1 ACMP0H Block Diagram .....	98
9.2 ACMP1H Block Diagram .....	99
9.3 ACMP2L Block Diagram .....	100
9.4 ACMP3L Block Diagram .....	101
9.5 ACMP Typical Performance .....	102
<b>10 Programmable Delay/Edge Detector</b> .....	<b>105</b>
10.1 Programmable Delay Timing Diagram - Edge Detector Output .....	105
<b>11 Additional Logic Function. Deglitch Filter</b> .....	<b>106</b>

**Auto AEC-Q100 Qualified GreenPAK Programmable  
Mixed-Signal Matrix**

<b>12 Voltage Reference</b> .....	<b>107</b>
12.1 Voltage Reference Overview .....	107
12.2 Vref Selection Table .....	107
12.3 Vref Block Diagram .....	108
12.4 Vref Load Regulation .....	109
<b>13 Clocking</b> .....	<b>111</b>
13.1 OSC General description .....	111
13.2 Oscillator0 (2.048 kHz) .....	112
13.3 Oscillator1 (2.048 MHz) .....	113
13.4 Oscillator2 (25 MHz) .....	114
13.5 CNT/DLY Clock Scheme .....	114
13.6 External Clocking .....	115
13.7 Oscillators Power-On Delay .....	116
13.8 Oscillators Accuracy .....	118
<b>14 Power-On Reset</b> .....	<b>120</b>
14.1 General Operation .....	120
14.2 POR Sequence .....	121
14.3 Macrocells Output States During POR Sequence .....	121
<b>15 I<sup>2</sup>C Serial Communications Macrocell</b> .....	<b>124</b>
15.1 I <sup>2</sup> C Serial Communications Macrocell Overview .....	124
15.2 I <sup>2</sup> C Serial Communications Device Addressing .....	124
15.3 I <sup>2</sup> C Serial General Timing .....	125
15.4 I <sup>2</sup> C Serial Communications Commands .....	125
15.5 I <sup>2</sup> C Serial Command Register Map .....	129
15.6 I <sup>2</sup> C Additional Options .....	130
<b>16 Analog Temperature Sensor</b> .....	<b>132</b>
<b>17 Register Definitions</b> .....	<b>135</b>
17.1 Register Map .....	135
<b>18 Package Top Marking Definitions</b> .....	<b>193</b>
18.1 FCQFN 14L 3mm x 3 mm 0.65P FCD .....	193
<b>19 Package Information</b> .....	<b>194</b>
19.1 Package Outlines for FCQFN 14L 3.0 mm x 3.0 mm x 0.55 mm 0.65P FC Package .....	194
19.2 FCQFN Handling .....	195
19.3 Soldering Information .....	195
<b>20 Ordering Information</b> .....	<b>195</b>
20.1 Tape and Reel Specifications .....	195
20.2 Carrier Tape Drawing and Dimensions .....	195
<b>21 Layout Guidelines</b> .....	<b>196</b>
21.1 FCQFN 14L 3 mm x 3 mm x 0.5 mm 0.65P FC Green .....	196
<b>Glossary</b> .....	<b>197</b>
<b>Revision History</b> .....	<b>200</b>

**Auto AEC-Q100 Qualified GreenPAK Programmable Mixed-Signal Matrix**
**Figures**

Figure 1: Block Diagram .....	7
Figure 2: Steps to Create a Custom GreenPAK Device .....	31
Figure 3: IO0 GPI Structure Diagram .....	33
Figure 4: GPIO with I <sup>2</sup> C Mode IO Structure Diagram .....	34
Figure 5: Matrix OE IO Structure Diagram.....	35
Figure 6: Matrix OE IO 4x Drive Structure Diagram .....	36
Figure 7: GPO Register OE 4x Drive Structure Diagram.....	37
Figure 8: Typical High Level Output Current vs. High Level Output Voltage at T = 25 °C .....	38
Figure 9: Typical Low Level Output Current vs. Low Level Output Voltage, 1x Drive at T = 25 °C, Full Range.....	38
Figure 10: Typical Low Level Output Current vs. Low Level Output Voltage, 1x Drive at T = 25 °C.....	39
Figure 11: Typical Low Level Output Current vs. Low Level Output Voltage, 2x Drive at T = 25 °C, Full Range.....	39
Figure 12: Typical Low Level Output Current vs. Low Level Output Voltage, 2x Drive at T = 25 °C.....	40
Figure 13: Typical Low Level Output Current vs. Low Level Output Voltage, 3.2x Drive at T = 25 °C, Full Range.....	40
Figure 14: Typical Low Level Output Current vs. Low Level Output Voltage, 3.2x Drive at T = 25 °C.....	41
Figure 15: Typical Low Level Output Current vs. Low Level Output Voltage, 4x Drive at T = 25 °C, Full Range.....	41
Figure 16: Typical Low Level Output Current vs. Low Level Output Voltage, 4x Drive at T = 25 °C.....	42
Figure 17: Connection Matrix.....	43
Figure 18: Connection Matrix Example.....	43
Figure 19: 2-bit LUT0 or DFF0.....	50
Figure 20: 2-bit LUT1 or DFF1.....	51
Figure 21: 2-bit LUT2 or DFF2.....	51
Figure 22: DFF Polarity Operations.....	53
Figure 23: 2-bit LUT3 or PGen .....	54
Figure 24: PGen Timing Diagram .....	54
Figure 25: 3-bit LUT0 or DFF3.....	56
Figure 26: 3-bit LUT1 or DFF4.....	57
Figure 27: 3-bit LUT2 or DFF5.....	57
Figure 28: 3-bit LUT3 or DFF6.....	58
Figure 29: 3-bit LUT4 or DFF7.....	58
Figure 30: 3-bit LUT5 or DFF8.....	59
Figure 31: 3-bit LUT6 or DFF9.....	59
Figure 32: 3-bit LUT7 or DFF10.....	60
Figure 33: 3-bit LUT8 or DFF11.....	60
Figure 34: DFF Polarity Operations with nReset .....	63
Figure 35: DFF Polarity Operations with nSet .....	64
Figure 36: 4-bit LUT0 or DFF12.....	65
Figure 37: 3-bit LUT16/Pipe Delay/Ripple Counter .....	67
Figure 38: Example: Ripple Counter Functionality .....	68
Figure 39: Possible Connections Inside Multi-Function Macrocell .....	70
Figure 40: 8-bit Multi-Function Macrocells Block Diagram (3-bit LUT9/DFF13, CNT/DLY1).....	71
Figure 41: 8-bit Multi-Function Macrocells Block Diagram (3-bit LUT10/DFF14, CNT/DLY2).....	72
Figure 42: 8-bit Multi-Function Macrocells Block Diagram (3-bit LUT11/DFF15, CNT/DLY3).....	73
Figure 43: 8-bit Multi-Function Macrocells Block Diagram (3-bit LUT12/DFF16, CNT/DLY4).....	74
Figure 44: 8-bit Multi-Function Macrocells Block Diagram (3-bit LUT13/DFF17, CNT/DLY5).....	75
Figure 45: 8-bit Multi-Function Macrocells Block Diagram (3-bit LUT14/DFF18, CNT/DLY6).....	76
Figure 46: 8-bit Multi-Function Macrocells Block Diagram (3-bit LUT15/DFF19, CNT/DLY7).....	77
Figure 47: 4-bit LUT1 or CNT/DLY0 .....	81
Figure 48: Delay Mode Timing Diagram, Edge Select: Both, Counter Data: 3 .....	83
Figure 49: Delay Mode Timing Diagram for Different Edge Select Mode.....	84
Figure 50: Counter Mode Timing Diagram without Two DFFs Synced Up.....	84
Figure 51: Counter Mode Timing Diagram with Two DFFs Synced Up .....	85
Figure 52: One-Shot Function Timing Diagram .....	86
Figure 53: Frequency Detection Mode Timing Diagram .....	87
Figure 54: Edge Detection Mode Timing Diagram.....	88
Figure 55: Delayed Edge Detection Mode Timing Diagram .....	89

**Auto AEC-Q100 Qualified GreenPAK Programmable Mixed-Signal Matrix**

Figure 56: CNT/FSM Timing Diagram (Reset Rising Edge Mode, Oscillator is Forced On, UP = 0) for Counter Data = 3.....	90
Figure 57: CNT/FSM Timing Diagram (Set Rising Edge Mode, Oscillator is Forced On, UP = 0) for Counter Data = 3.....	90
Figure 58: CNT/FSM Timing Diagram (Reset Rising Edge Mode, Oscillator is Forced On, UP = 1) for Counter Data = 3.....	91
Figure 59: CNT/FSM Timing Diagram (Set Rising Edge Mode, Oscillator is Forced On, UP = 1) for Counter Data = 3.....	91
Figure 60: Counter Value, Counter Data = 3.....	92
Figure 61: Wake/Sleep Controller.....	93
Figure 62: Wake/Sleep Timing Diagram, Normal Wake Mode, Counter Reset is Used.....	94
Figure 63: Wake/Sleep Timing Diagram, Short Wake Mode, Counter Reset is Used.....	94
Figure 64: Wake/Sleep Timing Diagram, Normal Wake Mode, Counter Set is Used.....	95
Figure 65: Wake/Sleep Timing Diagram, Short Wake Mode, Counter Set is Used.....	95
Figure 66: ACMP0H Block Diagram.....	98
Figure 67: ACMP1H Block Diagram.....	99
Figure 68: ACMP2L Block Diagram.....	100
Figure 69: ACMP3L Block Diagram.....	101
Figure 70: Typical Propagation Delay vs. Vref for ACMPxH at T = 25 °C, Gain = 1, Hysteresis = 0.....	102
Figure 71: Typical Propagation Delay vs. Vref for ACMPxL at T = 25 °C, Gain = 1, Hysteresis = 0.....	102
Figure 72: ACMPxH Power-On Delay vs. V <sub>DD</sub> .....	103
Figure 73: ACMPxL Power-On Delay vs. V <sub>DD</sub> .....	103
Figure 74: ACMPxH Input Offset Voltage vs. Vref at T = -40 °C to 105 °C.....	104
Figure 75: ACMPxL Input Offset Voltage vs. Vref at T = -40 °C to 105 °C.....	104
Figure 76: Programmable Delay.....	105
Figure 77: Edge Detector Output.....	105
Figure 78: Deglitch Filter/Edge Detector.....	106
Figure 79: Voltage Reference Block Diagram.....	108
Figure 80: Typical Load Regulation, Vref = 320 mV, T = -40 °C to +105 °C, Buffer - Enabled.....	109
Figure 81: Typical Load Regulation, Vref = 640 mV, T = -40 °C to +105 °C, Buffer - Enabled.....	109
Figure 82: Typical Load Regulation, Vref = 1280 mV, T = -40 °C to +105 °C, Buffer - Enabled.....	110
Figure 83: Typical Load Regulation, Vref = 2016 mV, T = -40 °C to +105 °C, Buffer - Enabled.....	110
Figure 84: Oscillator0 Block Diagram.....	112
Figure 85: Oscillator1 Block Diagram.....	113
Figure 86: Oscillator2 Block Diagram.....	114
Figure 87: Clock Scheme.....	115
Figure 88: Oscillator Startup Diagram.....	116
Figure 89: Oscillator0 Maximum Power-On Delay vs. V <sub>DD</sub> at T = 25 °C, OSC0 = 2.048 kHz.....	116
Figure 90: Oscillator1 Maximum Power-On Delay vs. V <sub>DD</sub> at T = 25 °C, OSC1 = 2.048 MHz.....	117
Figure 91: Oscillator2 Maximum Power-On Delay vs. V <sub>DD</sub> at T = 25 °C, OSC2 = 25 MHz.....	117
Figure 92: Oscillator0 Frequency vs. Temperature, OSC0 = 2.048 kHz.....	118
Figure 93: Oscillator1 Frequency vs. Temperature, OSC1 = 2.048 MHz.....	118
Figure 94: Oscillator2 Frequency vs. Temperature, OSC2 = 25 MHz.....	119
Figure 95: Oscillators Total Error vs. Temperature.....	119
Figure 96: POR Sequence.....	121
Figure 97: Internal Macrocell States During POR Sequence.....	122
Figure 98: Power-Down.....	123
Figure 99: Basic Command Structure.....	125
Figure 100: I <sup>2</sup> C General Timing Characteristics.....	125
Figure 101: Byte Write Command, R/W = 0.....	126
Figure 102: Sequential Write Command.....	126
Figure 103: Current Address Read Command, R/W = 1.....	127
Figure 104: Random Read Command.....	127
Figure 105: Sequential Read Command.....	128
Figure 106: Reset Command Timing.....	128
Figure 107: Example of I <sup>2</sup> C Byte Write Bit Masking.....	131
Figure 108: Analog Temperature Sensor Structure Diagram.....	133
Figure 109: TS Output vs. Temperature, V <sub>DD</sub> = 2.3 V to 5.5 V.....	134

**Auto AEC-Q100 Qualified GreenPAK Programmable Mixed-Signal Matrix**
**Tables**

Table 1: Functional Pin Description .....	8
Table 2: Pin Type Definitions .....	11
Table 3: Absolute Maximum Ratings .....	12
Table 4: Electrostatic Discharge Ratings .....	12
Table 5: Recommended Operating Conditions .....	12
Table 6: EC at $T_A = -40\text{ }^\circ\text{C}$ to $+105\text{ }^\circ\text{C}$ , $V_{DD} = 2.3\text{ V}$ to $5.5\text{ V}$ Unless Otherwise Noted .....	13
Table 7: EC of the I <sup>2</sup> C Pins for DI Mode at $T_A = -40\text{ }^\circ\text{C}$ to $+105\text{ }^\circ\text{C}$ , $V_{DD} = 2.3\text{ V}$ to $5.5\text{ V}$ Unless Otherwise Noted .....	16
Table 8: EC of the I <sup>2</sup> C Pins for DILV Mode at $T_A = -40\text{ }^\circ\text{C}$ to $+105\text{ }^\circ\text{C}$ , $V_{DD} = 2.3\text{ V}$ to $5.5\text{ V}$ Unless Otherwise Noted .....	17
Table 9: I <sup>2</sup> C Pins Timing Characteristics, DI Mode, $T_A = -40\text{ }^\circ\text{C}$ to $+105\text{ }^\circ\text{C}$ , $V_{DD} = 2.3\text{ V}$ to $5.5\text{ V}$ Unless Otherwise Noted .....	17
Table 10: I <sup>2</sup> C Pins Timing Characteristics, DILV Mode, $T_A = -40\text{ }^\circ\text{C}$ to $+105\text{ }^\circ\text{C}$ , $V_{DD} = 2.3\text{ V}$ to $5.5\text{ V}$ Unless Otherwise Noted .....	18
Table 11: Typical Current Estimated for Each Macrocell at $T_A = 25\text{ }^\circ\text{C}$ .....	20
Table 12: Typical Delay Estimated for Each Macrocell at $T_A = 25\text{ }^\circ\text{C}$ .....	20
Table 13: Typical Propagations Delays and Pulse Widths at $T_A = 25\text{ }^\circ\text{C}$ .....	24
Table 14: Typical Filter Rejection Pulse Width at $T_A = 25\text{ }^\circ\text{C}$ .....	24
Table 15: Typical Counter/Delay Offset at $T_A = 25\text{ }^\circ\text{C}$ .....	24
Table 16: Oscillators Frequency Limits, $V_{DD} = 2.3\text{ V}$ to $5.5\text{ V}$ .....	25
Table 17: Oscillators Power-On Delay at $T_A = -40\text{ }^\circ\text{C}$ to $+105\text{ }^\circ\text{C}$ , OSC Power Setting: "Auto Power-On" .....	25
Table 18: ACMP Specifications at $T_A = -40\text{ }^\circ\text{C}$ to $+105\text{ }^\circ\text{C}$ , $V_{DD} = 2.3\text{ V}$ to $5.5\text{ V}$ Unless Otherwise Noted .....	25
Table 19: TS Output vs Temperature (Output Range 1), $V_{DD} = 2.3\text{ V}$ to $5.5\text{ V}$ .....	29
Table 20: TS Output vs Temperature (Output Range 2), $V_{DD} = 2.3\text{ V}$ to $5.5\text{ V}$ .....	29
Table 21: TS Output Error (Output Range 1), $V_{DD} = 2.3\text{ V}$ to $5.5\text{ V}$ .....	30
Table 22: TS Output Error (Output Range 2), $V_{DD} = 2.3\text{ V}$ to $5.5\text{ V}$ .....	30
Table 23: Matrix Input Table .....	44
Table 24: Matrix Output Table .....	46
Table 25: Connection Matrix Virtual Inputs .....	49
Table 26: 2-bit LUT0 Truth Table .....	52
Table 27: 2-bit LUT1 Truth Table .....	52
Table 28: 2-bit LUT2 Truth Table .....	52
Table 29: 2-bit LUT Standard Digital Functions .....	52
Table 30: 2-bit LUT3 Truth Table .....	55
Table 31: 2-bit LUT Standard Digital Functions .....	55
Table 32: 3-bit LUT0 Truth Table .....	61
Table 33: 3-bit LUT1 Truth Table .....	61
Table 34: 3-bit LUT2 Truth Table .....	61
Table 35: 3-bit LUT3 Truth Table .....	61
Table 36: 3-bit LUT4 Truth Table .....	61
Table 37: 3-bit LUT5 Truth Table .....	61
Table 38: 3-bit LUT6 Truth Table .....	61
Table 39: 3-bit LUT7 Truth Table .....	61
Table 40: 3-bit LUT8 Truth Table .....	62
Table 41: 3-bit LUT Standard Digital Functions .....	62
Table 42: 4-bit LUT0 Truth Table .....	65
Table 43: 4-bit LUT Standard Digital Functions .....	66
Table 44: 3-bit LUT16 Truth Table .....	69
Table 45: 3-bit LUT9 Truth Table .....	78
Table 46: 3-bit LUT10 Truth Table .....	78
Table 47: 3-bit LUT11 Truth Table .....	78
Table 48: 3-bit LUT12 Truth Table .....	78
Table 49: 3-bit LUT13 Truth Table .....	78
Table 50: 3-bit LUT14 Truth Table .....	78
Table 51: 3-bit LUT15 Truth Table .....	78
Table 52: 4-bit LUT1 Truth Table .....	82
Table 53: 4-bit LUT Standard Digital Functions .....	82
Table 54: Vref Selection Table .....	107
Table 55: Oscillator Operation Mode Configuration Settings .....	111
Table 56: Read/Write Protection Options .....	129
Table 57: Register Map .....	135

SLG46855-A

Auto AEC-Q100 Qualified GreenPAK Programmable Mixed-Signal Matrix

1 Block Diagram

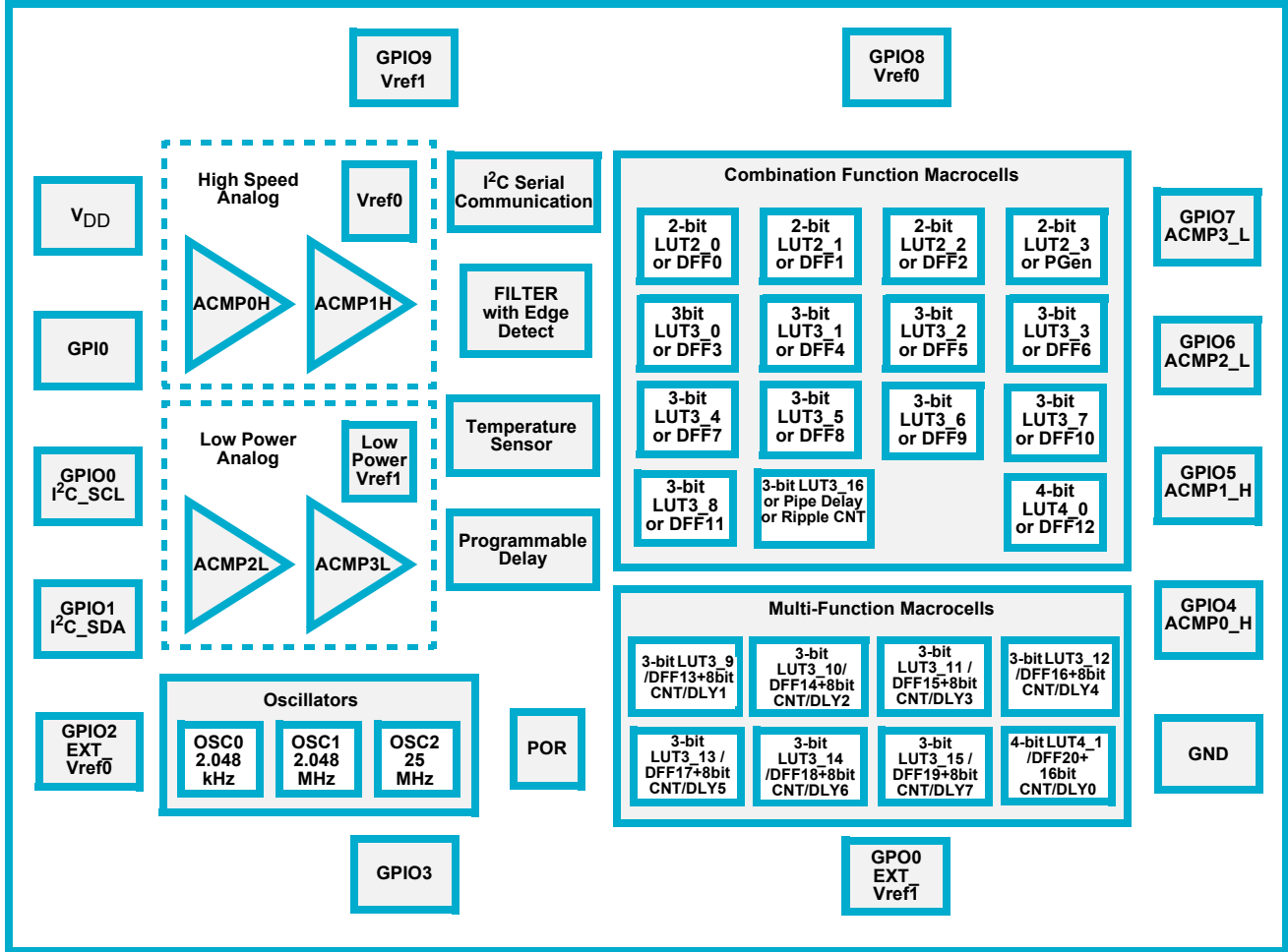

Figure 1: Block Diagram

# SLG46855-A

## Auto AEC-Q100 Qualified GreenPAK Programmable Mixed-Signal Matrix

### 2 Pinout

#### 2.1 PIN CONFIGURATION - FCQFN- 14L

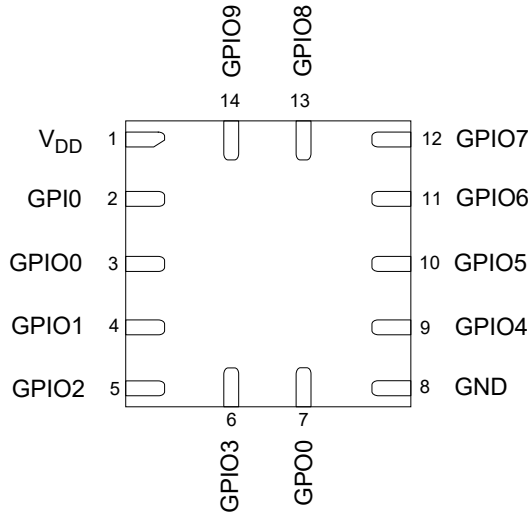

**FCQFN-14L  
(Top View)**

Pin #	Pin Name	Pin Functions
1	V <sub>DD</sub>	Power Supply
2	GPIO0	GPI, SLA_0
3	GPIO0	GPIO, SCL
4	GPIO1	GPIO, SDA
5	GPIO2	GPIO with OE, EXT_Vref0, SLA_1
6	GPIO3	GPIO with OE
7	GPO0	GPO, EXT_Vref1
8	GND	Ground
9	GPIO4	GPIO with OE, ACMP0_H+, SLA_2
10	GPIO5	GPIO with OE, ACMP1_H+, SLA_3
11	GPIO6	GPIO with OE, ACMP2_L+
12	GPIO7	GPIO with OE, ACMP3_L+
13	GPIO8	GPIO with OE, Vref0_OUT, TS_OUT
14	GPIO9	GPIO with OE, Vref1_OUT

Legend:

- OE: Output Enable
- ACMPx+: ACMPx Positive Input
- ACMPx-: ACMPx Negative Input
- SCL: I<sup>2</sup>C Clock Input
- SDA: I<sup>2</sup>C Data Input/Output
- Vrefx: Voltage Reference Output
- EXT\_CLKx: External Clock Input
- SLA: Slave Address
- TS\_OUT: Temperature Output

**Table 1: Functional Pin Description**

FCQFN 14L Pin #	Pin Name	Signal Name	Function	Input Options	Output Options
1	V <sub>DD</sub>	V <sub>DD</sub>	Power Supply	--	--
		ACMP0_H+	Analog Comparator 0 Positive Input	Analog	--
		ACMP1_H+	Analog Comparator 1 Positive Input	Analog	--
		ACMP2_L+	Analog Comparator 2 Positive Input	Analog	--
		ACMP3_L+	Analog Comparator 3 Positive Input	Analog	--
2	GPIO0	GPIO0	General Purpose Input	Digital Input without Schmitt Trigger	--
				Digital Input with Schmitt Trigger	--
				Low Voltage Digital Input	--
		Slave Address 0	--	--	



**Auto AEC-Q100 Qualified GreenPAK Programmable Mixed-Signal Matrix**
**Table 1: Functional Pin Description(Continued)**

FCQFN 14L Pin #	Pin Name	Signal Name	Function	Input Options	Output Options
3	GPIO0	GPIO0	General Purpose IO with OE <b>(Note 1)</b>	Digital Input without Schmitt Trigger	Open-Drain NMOS (3.2x)
				Digital Input with Schmitt Trigger	
				Low Voltage Digital Input	--
	SCL	I <sup>2</sup> C Serial Clock	Digital Input without Schmitt Trigger	--	
			Digital Input with Schmitt Trigger	--	
			Low Voltage Digital Input	--	
4	GPIO1	GPIO1	General Purpose IO	Digital Input without Schmitt Trigger	Open-Drain NMOS (3.2x)
				Digital Input with Schmitt Trigger	
				Low Voltage Digital Input	
	SDA	I <sup>2</sup> C Serial Data	Digital Input without Schmitt Trigger	--	
			Digital Input with Schmitt Trigger	--	
			Low Voltage Digital Input	--	
5	GPIO2	GPIO2	General Purpose IO with OE <b>(Note 1)</b>	Digital Input without Schmitt Trigger	Push-Pull (1x) (2x)
				Digital Input with Schmitt Trigger	Open-Drain NMOS (1x) (2x)
				Low Voltage Digital Input	--
	Slave Address 1		--	--	
EXT_VREF0	Analog Comparator Negative Input	Analog	--		
6	GPIO3	GPIO3	General Purpose IO with OE <b>(Note 1)</b>	Digital Input without Schmitt Trigger	Push-Pull (1x) (2x)
				Digital Input with Schmitt Trigger	Open-Drain NMOS (1x) (2x)
				Low Voltage Digital Input	--
7	GPO0	GPO0	General Purpose Output	--	Push-Pull (1x) (2x)
				--	Open-Drain NMOS (1x) (2x) (4x)
	EXT_VREF1	Analog Comparator Negative Input	Analog	--	
8	GND	GND	Power Supply	--	--

**Auto AEC-Q100 Qualified GreenPAK Programmable Mixed-Signal Matrix**
**Table 1: Functional Pin Description(Continued)**

FCQFN 14L Pin #	Pin Name	Signal Name	Function	Input Options	Output Options
9	GPIO4	GPIO4	General Purpose IO with OE (Note 1)	Digital Input without Schmitt Trigger	Push-Pull (1x) (2x)
				Digital Input with Schmitt Trigger	Open-Drain NMOS (1x) (2x) (4x)
				Low Voltage Digital Input	--
		ACMP0_H+	Analog Comparator 0_H Positive Input	Analog	--
	Slave Address 2			--	--
10	GPIO5	GPIO5	General Purpose IO with OE (Note 1)	Digital Input without Schmitt Trigger	Push-Pull (1x) (2x)
				Digital Input with Schmitt Trigger	Open-Drain NMOS (1x) (2x)
				Low Voltage Digital Input	--
		ACMP1_H+	Analog Comparator 1_H Positive Input	Analog	--
	Slave Address 3			--	--
11	GPIO6	GPIO6	General Purpose IO with OE (Note 1)	Digital Input without Schmitt Trigger	Push-Pull (1x) (2x)
				Digital Input with Schmitt Trigger	Open-Drain NMOS (1x) (2x)
				Low Voltage Digital Input	--
		ACMP2_L+	Analog Comparator 2_L Positive Input	Analog	--
12	GPIO7	GPIO7	General Purpose IO with OE (Note 1)	Digital Input without Schmitt Trigger	Push-Pull (1x) (2x)
				Digital Input with Schmitt Trigger	Open-Drain NMOS (1x) (2x)
				Low Voltage Digital Input	--
		ACMP3_L+	Analog Comparator 3_L Positive Input	Analog	--
13	GPIO8	GPIO8	General Purpose IO with OE (Note 1)	Digital Input without Schmitt Trigger	Push-Pull (1x) (2x)
				Digital Input with Schmitt Trigger	Open-Drain NMOS (1x) (2x)
				Low Voltage Digital Input	--
		Vref0	Vref0 Output	Analog	--
14	GPIO9	GPIO9	General Purpose IO with OE (Note 1)	Digital Input without Schmitt Trigger	Push-Pull (1x) (2x)
				Digital Input with Schmitt Trigger	Open-Drain NMOS (1x) (2x)
				Low Voltage Digital Input	--
		Vref1	Vref1 Output	Analog	--

**Note 1** General Purpose IO's with OE can be used to implement bidirectional signals under user control via Connection Matrix to OE signal in IO structure.

## SLG46855-A

### Auto AEC-Q100 Qualified GreenPAK Programmable Mixed-Signal Matrix

**Table 2: Pin Type Definitions**

Pin Type	Description
V <sub>DD</sub>	Power Supply
GPI	General Purpose Input
GPIO	General Purpose Input/Output
GPO	General Purpose Output
GND	Ground

# SLG46855-A

## Auto AEC-Q100 Qualified GreenPAK Programmable Mixed-Signal Matrix

### 3 Characteristics

#### 3.1 ABSOLUTE MAXIMUM RATINGS

Stresses beyond those listed under Absolute Maximum Ratings may cause permanent damage to the device. These are stress ratings only, so functional operation of the device at these or any other conditions beyond those indicated in the operational sections of the specification are not implied. Exposure to Absolute Maximum Rating conditions for extended periods may affect device reliability.

**Table 3: Absolute Maximum Ratings**

Parameter		Min	Max	Unit
Supply Voltage on $V_{DD}$ relative to GND		-0.3	7	V
DC Input Voltage		GND - 0.5 V	$V_{DD} + 0.5$ V	V
Maximum Average or DC Current (Through $V_{DD}$ or GND pin)		--	90	mA
Maximum Average or DC Current (Through pin)	Push-Pull 1x	--	11	mA
	Push-Pull 2x	--	16	
	Push-Pull 4x	--	32	
	OD 1x	--	11	
	OD 2x	--	21	
	OD 4x	--	43	
Current at Input Pin		-1.0	1.0	mA
Input Leakage Current (Absolute Value)		--	1000	nA
Storage Temperature Range		-65	150	°C
Junction Temperature		--	150	°C
Moisture Sensitive Level		1		

#### 3.2 ELECTROSTATIC DISCHARGE RATINGS

**Table 4: Electrostatic Discharge Ratings**

Parameter	Min	Max	Unit
ESD Protection (Human Body Model)	2000	--	V
ESD Protection (Charged Device Model)	1300	--	V

#### 3.3 RECOMMENDED OPERATING CONDITIONS

**Table 5: Recommended Operating Conditions**

Parameter	Condition	Min	Max	Unit
Supply Voltage ( $V_{DD}$ )		2.3	5.5	V
Operating Ambient Temperature		-40	105	°C
Maximal Voltage Applied to any PIN in High Impedance State		--	$V_{DD} + 0.3$	V
Capacitor Value at $V_{DD}$		0.1	--	μF
Analog Input Common Mode Range	Allowable Input Voltage at Analog Pins	0	$V_{DD}$	V

# SLG46855-A

## Auto AEC-Q100 Qualified GreenPAK Programmable Mixed-Signal Matrix

### 3.4 ELECTRICAL CHARACTERISTICS

Table 6: EC at  $T_A = -40\text{ }^\circ\text{C}$  to  $+105\text{ }^\circ\text{C}$ ,  $V_{DD} = 2.3\text{ V}$  to  $5.5\text{ V}$  Unless Otherwise Noted

Parameter	Description	Condition	Min	Typ	Max	Unit
$V_{IH}$	HIGH-Level Input Voltage	Logic Input ( <b>Note 1</b> )	$0.7 \times V_{DD}$	--	$V_{DD} + 0.3$	V
		Logic Input with Schmitt Trigger	$0.8 \times V_{DD}$	--	$V_{DD} + 0.3$	V
		Low-Level Logic Input ( <b>Note 1</b> )	1.25	--	$V_{DD} + 0.3$	V
$V_{IL}$	LOW-Level Input Voltage	Logic Input ( <b>Note 1</b> )	GND-0.3	--	$0.3 \times V_{DD}$	V
		Logic Input with Schmitt Trigger	GND-0.3	--	$0.2 \times V_{DD}$	V
		Low-Level Logic Input ( <b>Note 1</b> )	GND-0.3	--	0.5	V
$V_{OH}$	HIGH-Level Output Voltage	Push-Pull, 1x Drive, $V_{DD} = 2.3\text{ V}$ , $I_{OH} = 1\text{ mA}$	2.17	--	--	V
		Push-Pull, 1x Drive, $V_{DD} = 3.3\text{ V}$ , $I_{OH} = 3\text{ mA}$	3.02	--	--	V
		Push-Pull, 1x Drive, $V_{DD} = 5.5\text{ V}$ , $I_{OH} = 5\text{ mA}$	5.19	--	--	V
		Push-Pull, 2x Drive, $V_{DD} = 2.3\text{ V}$ , $I_{OH} = 1\text{ mA}$	2.23	--	--	V
		Push-Pull, 2x Drive, $V_{DD} = 3.3\text{ V}$ , $I_{OH} = 3\text{ mA}$	3.16	--	--	V
		Push-Pull, 2x Drive, $V_{DD} = 5.5\text{ V}$ , $I_{OH} = 5\text{ mA}$	5.34	--	--	V
		Push-Pull, 4x Drive (only for GPO0 and GPIO4), $V_{DD} = 2.3\text{ V}$ , $I_{OH} = 1\text{ mA}$	2.27	--	--	V
		Push-Pull, 4x Drive (only for GPO0 and GPIO4), $V_{DD} = 3.3\text{ V}$ , $I_{OH} = 3\text{ mA}$	3.23	--	--	V
		Push-Pull, 4x Drive (only for GPO0 and GPIO4), $V_{DD} = 5.5\text{ V}$ , $I_{OH} = 5\text{ mA}$	5.41	--	--	V
$V_{OL}$	LOW-Level Output Voltage	Push-Pull, 1x Drive, $V_{DD} = 2.3\text{ V}$ , $I_{OL} = 1\text{ mA}$	--	--	0.100	V
		Push-Pull, 1x Drive, $V_{DD} = 3.3\text{ V}$ , $I_{OL} = 3\text{ mA}$	--	--	0.227	V
		Push-Pull, 1x Drive, $V_{DD} = 5.5\text{ V}$ , $I_{OL} = 5\text{ mA}$	--	--	0.272	V
		Push-Pull, 2x Drive, $V_{DD} = 2.3\text{ V}$ , $I_{OL} = 1\text{ mA}$	--	--	0.049	V
		Push-Pull, 2x Drive, $V_{DD} = 3.3\text{ V}$ , $I_{OL} = 3\text{ mA}$	--	--	0.112	V

# SLG46855-A

## Auto AEC-Q100 Qualified GreenPAK Programmable Mixed-Signal Matrix

Table 6: EC at  $T_A = -40\text{ }^{\circ}\text{C}$  to  $+105\text{ }^{\circ}\text{C}$ ,  $V_{DD} = 2.3\text{ V}$  to  $5.5\text{ V}$  Unless Otherwise Noted (Continued)

Parameter	Description	Condition	Min	Typ	Max	Unit
$V_{OL}$	LOW-Level Output Voltage	Push-Pull, 2x Drive, $V_{DD} = 5.5\text{ V}$ , $I_{OL} = 5\text{ mA}$	--	--	0.137	V
		Push-Pull, 4x Drive (only for GPO0 and GPIO4), $V_{DD} = 2.3\text{ V}$ , $I_{OL} = 1\text{ mA}$	--	--	0.023	V
		Push-Pull, 4x Drive (only for GPO0 and GPIO4), $V_{DD} = 3.3\text{ V}$ , $I_{OL} = 3\text{ mA}$	--	--	0.055	V
		Push-Pull, 4x Drive (only for GPO0 and GPIO4), $V_{DD} = 5.5\text{ V}$ , $I_{OL} = 5\text{ mA}$	--	--	0.067	V
		NMOS OD, 1x Drive, $V_{DD} = 2.3\text{ V}$ , $I_{OL} = 1\text{ mA}$	--	--	0.042	V
		NMOS OD, 1x Drive, $V_{DD} = 3.3\text{ V}$ , $I_{OL} = 3\text{ mA}$	--	--	0.093	V
		NMOS OD, 1x Drive, $V_{DD} = 5.5\text{ V}$ , $I_{OL} = 5\text{ mA}$	--	--	0.117	V
		NMOS OD, 2x Drive, $V_{DD} = 2.3\text{ V}$ , $I_{OL} = 1\text{ mA}$	--	--	0.020	V
		NMOS OD, 2x Drive, $V_{DD} = 3.3\text{ V}$ , $I_{OL} = 3\text{ mA}$	--	--	0.047	V
		NMOS OD, 2x Drive, $V_{DD} = 5.5\text{ V}$ , $I_{OL} = 5\text{ mA}$	--	--	0.058	V
		NMOS OD, 4x Drive (only for GPO0 and GPIO4), $V_{DD} = 2.3\text{ V}$ , $I_{OL} = 1\text{ mA}$	--	--	0.009	V
		NMOS OD, 4x Drive (only for GPO0 and GPIO4), $V_{DD} = 3.3\text{ V}$ , $I_{OL} = 3\text{ mA}$	--	--	0.022	V
		NMOS OD, 4x Drive (only for GPO0 and GPIO4), $V_{DD} = 5.5\text{ V}$ , $I_{OL} = 5\text{ mA}$	--	--	0.027	V
		$I_{OH}$	HIGH-Level Output Pulse Current (Note 2)	Push-Pull, 1x Drive, $V_{DD} = 2.3\text{ V}$ , $V_{OH} = V_{DD} - 0.2\text{ V}$	1.44	--
Push-Pull, 1x Drive, $V_{DD} = 3.3\text{ V}$ , $V_{OH} = 2.4\text{ V}$	7.75			--	--	mA
Push-Pull, 1x Drive, $V_{DD} = 5.5\text{ V}$ , $V_{OH} = 2.75\text{ V}$	26.98			--	--	mA
Push-Pull, 2x Drive, $V_{DD} = 2.3\text{ V}$ , $V_{OH} = V_{DD} - 0.2\text{ V}$	2.82			--	--	mA
Push-Pull, 2x Drive, $V_{DD} = 3.3\text{ V}$ , $V_{OH} = 2.4\text{ V}$	15.12			--	--	mA
Push-Pull, 2x Drive, $V_{DD} = 5.5\text{ V}$ , $V_{OH} = 2.75\text{ V}$	51.97			--	--	mA
Push-Pull, 4x Drive (only for GPO0 and GPIO4), $V_{DD} = 2.3\text{ V}$ , $V_{OH} = V_{DD} - 0.2\text{ V}$	5.47			--	--	mA
Push-Pull, 4x Drive (only for GPO0 and GPIO4), $V_{DD} = 3.3\text{ V}$ , $V_{OH} = 2.4\text{ V}$	28.97			--	--	mA

**Auto AEC-Q100 Qualified GreenPAK Programmable Mixed-Signal Matrix**
**Table 6: EC at  $T_A = -40\text{ }^\circ\text{C}$  to  $+105\text{ }^\circ\text{C}$ ,  $V_{DD} = 2.3\text{ V}$  to  $5.5\text{ V}$  Unless Otherwise Noted (Continued)**

Parameter	Description	Condition	Min	Typ	Max	Unit
$I_{OH}$	HIGH-Level Output Pulse Current (Note 2)	Push-Pull, 4x Drive (only for GPO0 and GPIO4), $V_{DD} = 5.5\text{ V}$ , $V_{OH} = 2.75\text{ V}$	97.85	--	--	mA
$I_{OL}$	LOW-Level Output Pulse Current (Note 2)	Push-Pull, 1x Drive, $V_{DD} = 2.3\text{ V}$ , $V_{OL} = 0.2\text{ V}$	1.92	--	--	mA
		Push-Pull, 1x Drive, $V_{DD} = 3.3\text{ V}$ , $V_{OL} = 0.4\text{ V}$	5.01	--	--	mA
		Push-Pull, 1x Drive, $V_{DD} = 5.5\text{ V}$ , $V_{OL} = 0.4\text{ V}$	7.10	--	--	mA
		Push-Pull, 2x Drive, $V_{DD} = 2.3\text{ V}$ , $V_{OL} = 0.2\text{ V}$	3.84	--	--	mA
		Push-Pull, 2x Drive, $V_{DD} = 3.3\text{ V}$ , $V_{OL} = 0.4\text{ V}$	9.96	--	--	mA
		Push-Pull, 2x Drive, $V_{DD} = 5.5\text{ V}$ , $V_{OL} = 0.4\text{ V}$	13.96	--	--	mA
		Push-Pull, 4x Drive (only for GPO0 and GPIO4), $V_{DD} = 2.3\text{ V}$ , $V_{OL} = 0.2\text{ V}$	7.72	--	--	mA
		Push-Pull, 4x Drive (only for GPO0 and GPIO4), $V_{DD} = 3.3\text{ V}$ , $V_{OL} = 0.4\text{ V}$	20.12	--	--	mA
		Push-Pull, 4x Drive (only for GPO0 and GPIO4), $V_{DD} = 5.5\text{ V}$ , $V_{OL} = 0.4\text{ V}$	28.34	--	--	mA
		NMOS OD, 1x Drive, $V_{DD} = 2.3\text{ V}$ , $V_{OL} = 0.2\text{ V}$	4.71	--	--	mA
		NMOS OD, 1x Drive, $V_{DD} = 3.3\text{ V}$ , $V_{OL} = 0.4\text{ V}$	12.21	--	--	mA
		NMOS OD, 1x Drive, $V_{DD} = 5.5\text{ V}$ , $V_{OL} = 0.4\text{ V}$	16.95	--	--	mA
		NMOS OD, 2x Drive, $V_{DD} = 2.3\text{ V}$ , $V_{OL} = 0.2\text{ V}$	9.24	--	--	mA
		NMOS OD, 2x Drive, $V_{DD} = 3.3\text{ V}$ , $V_{OL} = 0.4\text{ V}$	23.68	--	--	mA
		NMOS OD, 2x Drive, $V_{DD} = 5.5\text{ V}$ , $V_{OL} = 0.4\text{ V}$	32.64	--	--	mA
		NMOS OD, 4x Drive (only for GPO0 and GPIO4), $V_{DD} = 2.3\text{ V}$ , $V_{OL} = 0.2\text{ V}$	18.96	--	--	mA
		NMOS OD, 4x Drive (only for GPO0 and GPIO4), $V_{DD} = 3.3\text{ V}$ , $V_{OL} = 0.4\text{ V}$	49.08	--	--	mA
		NMOS OD, 4x Drive (only for GPO0 and GPIO4), $V_{DD} = 5.5\text{ V}$ , $V_{OL} = 0.4\text{ V}$	68.27	--	--	mA
$T_{SU}$	Startup Time	From $V_{DD}$ rising past $PON_{THR}$ , $T_{RAMP} = 10\text{ ms}$	--	1.4	2.1	ms
$PON_{THR}$	Power-On Threshold	$V_{DD}$ Level Required to Start Up the Chip	1.56	1.84	2.03	V

**Auto AEC-Q100 Qualified GreenPAK Programmable Mixed-Signal Matrix**
**Table 6: EC at  $T_A = -40\text{ }^\circ\text{C}$  to  $+105\text{ }^\circ\text{C}$ ,  $V_{DD} = 2.3\text{ V}$  to  $5.5\text{ V}$  Unless Otherwise Noted (Continued)**

Parameter	Description	Condition	Min	Typ	Max	Unit
POFF <sub>THR</sub>	Power-Off Threshold	$V_{DD}$ Level Required to Switch Off the Chip	0.83	1.16	1.63	V
R <sub>PULL</sub>	Pull-up or Pull-down Resistance	1 M for Pull-up: $V_{IN} = \text{GND}$	--	1	--	M $\Omega$
		1 M for Pull-down: $V_{IN} = V_{DD}$	--	1	--	M $\Omega$
		100 k for Pull-up: $V_{IN} = \text{GND}$	--	100	--	k $\Omega$
		100 k for Pull-down: $V_{IN} = V_{DD}$	--	100	--	k $\Omega$
		10 k For Pull-up: $V_{IN} = \text{GND}$	--	10	--	k $\Omega$
		10 k for Pull-down: $V_{IN} = V_{DD}$	--	10	--	k $\Omega$
C <sub>IN</sub>	Input Capacitance			4		pF
I <sub>LKG</sub>	Logic Input without Schmitt Trigger (Floating) Leakage	$V_{in} = V_{DD}$ , $V_{DD} = 2.3\text{ V}$ , All Pins	--	4.61	--	nA
		$V_{in} = V_{DD}$ , $V_{DD} = 3.3\text{ V}$ , All Pins	--	5.00	--	nA
		$V_{in} = V_{DD}$ , $V_{DD} = 5.5\text{ V}$ , All Pins	--	6.56	--	nA
		$V_{in} = 0$ , $V_{DD} = 2.3\text{ V}$ , All Pins	--	1.41	--	nA
		$V_{in} = 0$ , $V_{DD} = 3.3\text{ V}$ , All Pins	--	1.58	--	nA
		$V_{in} = 0$ , $V_{DD} = 5.5\text{ V}$ , All Pins	--	4.44	--	nA
	Logic Input with Schmitt Trigger (Floating) Leakage	$V_{in} = V_{DD}$ , $V_{DD} = 2.3\text{ V}$ , All Pins	--	4.72	--	nA
		$V_{in} = V_{DD}$ , $V_{DD} = 3.3\text{ V}$ , All Pins	--	5.10	--	nA
		$V_{in} = V_{DD}$ , $V_{DD} = 5.5\text{ V}$ , All Pins	--	6.64	--	nA
		$V_{in} = 0$ , $V_{DD} = 2.3\text{ V}$ , All Pins	--	1.46	--	nA
		$V_{in} = 0$ , $V_{DD} = 3.3\text{ V}$ , All Pins	--	1.62	--	nA
		$V_{in} = 0$ , $V_{DD} = 5.5\text{ V}$ , All Pins	--	4.48	--	nA
	Low-Level Logic Input (Floating) Leakage	$V_{in} = V_{DD}$ , $V_{DD} = 2.3\text{ V}$ , All Pins	--	4.64	--	nA
		$V_{in} = V_{DD}$ , $V_{DD} = 3.3\text{ V}$ , All Pins	--	5.01	--	nA
		$V_{in} = V_{DD}$ , $V_{DD} = 5.5\text{ V}$ , All Pins	--	6.52	--	nA
		$V_{in} = 0$ , $V_{DD} = 2.3\text{ V}$ , All Pins	--	1.43	--	nA
		$V_{in} = 0$ , $V_{DD} = 3.3\text{ V}$ , All Pins	--	1.59	--	nA
		$V_{in} = 0$ , $V_{DD} = 5.5\text{ V}$ , All Pins	--	4.43	--	nA

**Note 1** No hysteresis.

**Note 2** DC or average current through any pin should not exceed value given in Absolute Maximum Conditions.

**3.5 I<sup>2</sup>C PINS ELECTRICAL CHARACTERISTICS**
**Table 7: EC of the I<sup>2</sup>C Pins for DI Mode at  $T_A = -40\text{ }^\circ\text{C}$  to  $+105\text{ }^\circ\text{C}$ ,  $V_{DD} = 2.3\text{ V}$  to  $5.5\text{ V}$  Unless Otherwise Noted**

Parameter	Description	Condition	Fast-Mode		Fast-Mode Plus		Unit
			Min	Max	Min	Max	
V <sub>IL</sub>	LOW-level Input Voltage		-0.5	0.3xV <sub>DD</sub>	-0.5	0.3xV <sub>DD</sub>	V
V <sub>IH</sub>	HIGH-level Input Voltage		0.7xV <sub>DD</sub>	5.5	0.7xV <sub>DD</sub>	5.5	V
V <sub>HYS</sub>	Hysteresis of Schmitt Trigger Inputs		0.05xV <sub>DD</sub>	--	0.05xV <sub>DD</sub>	--	V



# SLG46855-A

## Auto AEC-Q100 Qualified GreenPAK Programmable Mixed-Signal Matrix

**Table 7: EC of the I<sup>2</sup>C Pins for DI Mode at T<sub>A</sub> = -40 °C to +105 °C, V<sub>DD</sub> = 2.3 V to 5.5 V Unless Otherwise Noted(Continued)**

Parameter	Description	Condition	Fast-Mode		Fast-Mode Plus		Unit
			Min	Max	Min	Max	
V <sub>OL1</sub>	LOW-Level Output Voltage 1	(Open-Drain or open collector) at 3 mA sink current V <sub>DD</sub> > 2 V	0	0.4	0	0.4	V
V <sub>OL2</sub>	LOW-Level Output Voltage 2	(Open-Drain or open collector) at 2 mA sink current V <sub>DD</sub> ≤ 2 V	0	0.2xV <sub>DD</sub>	0	0.2xV <sub>DD</sub>	V
t <sub>of</sub>	Output Fall Time from V <sub>IHmin</sub> to V <sub>ILmax</sub> (Note 1)		14x (V <sub>DD</sub> /5.5V)	250	10x (V <sub>DD</sub> /5.5V)	120	ns
I <sub>i</sub>	Input Current each IO Pin	0.1xV <sub>DD</sub> < V <sub>I</sub> < 0.9xV <sub>DDmax</sub>	-10	+10	-10	+10	μA
C <sub>i</sub>	Capacitance for each IO Pin		--	10	--	10	pF

**Note 1** Does not meet standard I<sup>2</sup>C specifications: t<sub>of</sub> = 20x(V<sub>DD</sub>/5.5V) (min).  
**Note 2** For Fast-mode Plus SDA pin must be configured as NMOS 3.2x Open-Drain, see register [796] in section 17.

**Table 8: EC of the I<sup>2</sup>C Pins for DILV Mode at T<sub>A</sub> = -40 °C to +105 °C, V<sub>DD</sub> = 2.3 V to 5.5 V Unless Otherwise Noted**

Parameter	Description	Condition	Fast-Mode		Unit
			Min	Max	
V <sub>IL</sub>	LOW-level Input Voltage (Note 1)		GND-0.3	0.5	V
V <sub>IH</sub>	HIGH-level Input Voltage (Note 1)		1.25	V <sub>DD</sub> +0.3	V
V <sub>HYS</sub>	Hysteresis of Schmitt Trigger Inputs		0.05xV <sub>DD</sub>	--	V
V <sub>OL1</sub>	LOW-Level Output Voltage 1	(Open-Drain or open collector) at 3mA sink current V <sub>DD</sub> > 2 V	0	0.4	V
V <sub>OL2</sub>	LOW-Level Output Voltage 2	(Open-Drain or open collector) at 2 mA sink current V <sub>DD</sub> ≤ 2 V	0	0.2xV <sub>DD</sub>	V
t <sub>of</sub>	Output Fall Time from V <sub>IHmin</sub> to V <sub>ILmax</sub> (Note 1)		14x (V <sub>DD</sub> /5.5V)	250	ns
I <sub>i</sub>	Input Current each IO Pin	0.1xV <sub>DD</sub> < V <sub>I</sub> < 0.9xV <sub>DDmax</sub>	-10	+10	μA
C <sub>i</sub>	Capacitance for each IO Pin		--	10	pF

**Note 1** Does not meet standard I<sup>2</sup>C specifications: V<sub>IL</sub> = -0.5 V (min), V<sub>IL</sub> = 0.3xV<sub>DD</sub> (max), V<sub>IH</sub> = 0.7xV<sub>DD</sub> (min), V<sub>IH</sub> = 5.5 V (max), t<sub>of</sub> = 20x(V<sub>DD</sub>/5.5V) (min).

**Table 9: I<sup>2</sup>C Pins Timing Characteristics, DI Mode, T<sub>A</sub> = -40 °C to +105 °C, V<sub>DD</sub> = 2.3 V to 5.5 V Unless Otherwise Noted**

Parameter	Description	Condition	Speed						Unit
			400 kHz			1 MHz			
			Min	Typ	Max	Min	Typ	Max	
F <sub>SCL</sub>	Clock Frequency, SCL		--	--	400	--	--	1000	kHz
t <sub>LOW</sub>	Clock Pulse Width Low		1300	--	--	500	--	--	ns

# SLG46855-A

## Auto AEC-Q100 Qualified GreenPAK Programmable Mixed-Signal Matrix

**Table 9: I<sup>2</sup>C Pins Timing Characteristics, DI Mode, T<sub>A</sub> = -40 °C to +105 °C, V<sub>DD</sub> = 2.3 V to 5.5 V Unless Otherwise Noted**

Parameter	Description	Condition	Speed						Unit
			400 kHz			1 MHz			
			Min	Typ	Max	Min	Typ	Max	
t <sub>HIGH</sub>	Clock Pulse Width High		600	--	--	260	--	--	ns
t <sub>I</sub>	Input Filter Spike Suppression (SCL, SDA) (Note 1)	V <sub>DD</sub> = 2.3 V	--	--	90	--	--	87	ns
		V <sub>DD</sub> = 3.3 V	--	--	90	--	--	87	
		V <sub>DD</sub> = 5.5 V	--	--	90	--	--	87	
t <sub>VD_ACK</sub>	Data Valid Acknowledge Time		--	--	900	--	--	450	ns
t <sub>BUF</sub>	Bus Free Time between Stop and Start		1300	--	--	500	--	--	ns
t <sub>HD_STA</sub>	Start Hold Time		600	--	--	260	--	--	ns
t <sub>SU_STA</sub>	Start Set-up Time		600	--	--	260	--	--	ns
t <sub>HD_DAT</sub>	Data Hold Time	Rising Edge	0	--	--	0	--	--	ns
		Falling Edge	0	--	--	0	--	--	ns
t <sub>SU_DAT</sub>	Data Set-up Time		100	--	--	50	--	--	ns
t <sub>R</sub>	Inputs Rise Time	C = 15 pF	--	--	300	--	--	120	ns
		C = 100 pF	--	--	300	--	--	120	ns
		C = 400 pF	--	--	300	--	--	120	ns
t <sub>F</sub>	Inputs Fall Time	C = 15 pF	--	--	300	--	--	120	ns
		C = 100 pF	--	--	300	--	--	120	ns
		C = 400 pF	--	--	300	--	--	120	ns
t <sub>SU_STO</sub>	Stop Set-up Time		600	--	--	260	--	--	ns
t <sub>VD_DAT</sub>	Data Valid Time		50	--	--	50	--	--	ns

**Note 1** Does not meet standard I<sup>2</sup>C specifications: t<sub>I</sub> = 95 ns for V<sub>DD</sub> = 2.3 V, t<sub>I</sub> = 95 ns for V<sub>DD</sub> = 3.3 V, t<sub>I</sub> = 111 ns for V<sub>DD</sub> = 5.5V for 400 kHz; t<sub>I</sub> = 168 ns for V<sub>DD</sub> = 2.3 V, t<sub>I</sub> = 157 ns for V<sub>DD</sub> = 3.3 V, t<sub>I</sub> = 156 ns for V<sub>DD</sub> = 5.5 V for 1 MHz.

**Note 2** Timing diagram can be found in the [Figure 100](#).

**Note 3** Please follow official I<sup>2</sup>C spec UM10204.

**Table 10: I<sup>2</sup>C Pins Timing Characteristics, DILV Mode, T<sub>A</sub> = -40°C to +105°C, V<sub>DD</sub> = 2.3V to 5.5V Unless Otherwise Noted**

Parameter	Description	Condition	Speed			Unit
			400 kHz			
			Min	Typ	Max	
F <sub>SCL</sub>	Clock Frequency, SCL		--	--	400	kHz
t <sub>LOW</sub>	Clock Pulse Width Low		1300	--	--	ns
t <sub>HIGH</sub>	Clock Pulse Width High		600	--	--	ns
t <sub>I</sub>	Input Filter Spike Suppression (SCL, SDA) (Note 1)	V <sub>DD</sub> = 2.3 V	--	--	300	ns
		V <sub>DD</sub> = 3.3 V	--	--	235	
		V <sub>DD</sub> = 5.5 V	--	--	185	
t <sub>VD_ACK</sub>	Data Valid Acknowledge Time		--	--	900	ns
t <sub>BUF</sub>	Bus Free Time between Stop and Start		1300	--	--	ns
t <sub>HD_STA</sub>	Start Hold Time		600	--	--	ns

**Auto AEC-Q100 Qualified GreenPAK Programmable Mixed-Signal Matrix**
**Table 10: I<sup>2</sup>C Pins Timing Characteristics, DILV Mode, T<sub>A</sub> = -40°C to +105°C, V<sub>DD</sub> = 2.3V to 5.5V Unless Otherwise Noted**

Parameter	Description	Condition	Speed			Unit
			400 kHz			
			Min	Typ	Max	
t <sub>SU_STA</sub>	Start Set-up Time		600	--	--	ns
t <sub>HD_DAT</sub>	Data Hold Time (Note 1)	Rising Edge	255	--	--	ns
		Falling Edge	0	--	--	ns
t <sub>SU_DAT</sub>	Data Set-up Time		100	--	--	ns
t <sub>R</sub>	Inputs Rise Time	C = 15 pF	--	--	300	ns
		C = 100 pF	--	--	300	ns
		C = 400pF	--	--	300	ns
t <sub>F</sub>	Inputs Fall Time	C = 15 pF	--	--	300	ns
		C = 100 pF	--	--	300	ns
		C = 400 pF	--	--	300	ns
t <sub>SU_STO</sub>	Stop Set-up Time		600	--	--	ns
t <sub>VD_DAT</sub>	Data Valid Time		50	--	--	ns

**Note 1** Does not meet standard I<sup>2</sup>C specifications: t<sub>r</sub> = 95 ns for V<sub>DD</sub> = 2.3 V, t<sub>r</sub> = 95 ns for V<sub>DD</sub> = 3.3 V, t<sub>r</sub> = 111 ns for V<sub>DD</sub> = 5.5 V; t<sub>HD\_DAT</sub> = 0 ns (min) for Rising Edge.

**Note 2** Timing diagram can be found in the [Figure 100](#).

**Note 3** Please follow official I<sup>2</sup>C spec UM10204.

**Note 4** When SCL Input is in Low-Level Logic mode max frequency is 400 kHz.

# SLG46855-A

## Auto AEC-Q100 Qualified GreenPAK Programmable Mixed-Signal Matrix

### 3.6 MACROCELLS CURRENT CONSUMPTION

Table 11: Typical Current Estimated for Each Macrocell at  $T_A = 25\text{ }^\circ\text{C}$

Parameter	Description	Note	$V_{DD} = 2.5\text{ V}$	$V_{DD} = 3.3\text{ V}$	$V_{DD} = 5.0\text{ V}$	Unit
$I_{DD}$	Current	Chip Quiescent	0.34	0.39	0.46	$\mu\text{A}$
		Vref0, SourceNone	7.61	7.67	7.88	$\mu\text{A}$
		Vref1, SourceNone	1.39	1.42	1.51	$\mu\text{A}$
		OSC2 25 MHz, pre-divider = 1, second divider = 1	50.46	62.63	90.60	$\mu\text{A}$
		OSC2 25 MHz, pre-divider = 4, second divider = 1	33.46	39.91	55.47	$\mu\text{A}$
		OSC2 25 MHz, pre-divider = 8, second divider = 1	30.35	35.75	49.03	$\mu\text{A}$
		OSC1 2.048 MHz, pre-divider = 1, second divider = 1	20.64	21.99	24.94	$\mu\text{A}$
		OSC1 2.048 MHz, pre-divider = 4, second divider = 1	18.56	19.21	20.61	$\mu\text{A}$
		OSC1 2.048 MHz, pre-divider = 8, second divider = 1	18.18	18.71	19.84	$\mu\text{A}$
		OSC0 2.048 kHz, pre-divider = 1, second divider = 1	0.62	0.66	0.77	$\mu\text{A}$
		OSC0 2.048 kHz, pre-divider = 4, second divider = 1	0.62	0.66	0.76	$\mu\text{A}$
		OSC0 2.048 kHz, pre-divider = 8, second divider = 1	0.61	0.66	0.76	$\mu\text{A}$
		Temperature Sensor, output range 1 (0.62 V to 0.99 V)	14.80	14.87	15.43	$\mu\text{A}$
		Temperature Sensor, output range 2 (0.75 V to 1.2 V)	14.94	15.02	15.43	$\mu\text{A}$
		All ACMPs (includes internal Vref, $V_{in+} = 0$ , Vref = 32 mV)	37.36	38.10	40.42	$\mu\text{A}$
		All ACMPxH (includes internal Vref, $V_{in+} = 0$ , Vref = 32 mV)	48.95	50.26	53.90	$\mu\text{A}$
		ACMP0H 100 $\mu\text{A}$ Enabled (includes internal Vref, $V_{in+} = 0$ , Vref = 32 mV)	35.95	36.65	38.92	$\mu\text{A}$
Any ACMPxL (includes internal Vref, $V_{in+} = 0$ , Vref = 32 mV)	1.89	1.93	2.04	$\mu\text{A}$		

### 3.7 TIMING CHARACTERISTICS

Table 12: Typical Delay Estimated for Each Macrocell at  $T_A = 25\text{ }^\circ\text{C}$

Parameter	Description	Note	$V_{DD} = 2.5\text{ V}$		$V_{DD} = 3.3\text{ V}$		$V_{DD} = 5\text{ V}$		Unit
			Rising	Falling	Rising	Falling	Rising	Falling	
tpd	Delay	Digital Input to PP 1x	23	26	17	19	12	15	ns
tpd	Delay	Digital Input to PP 2x	22	25	16	16	12	14	ns
tpd	Delay	Digital Input with Schmitt Trigger to PP 1x	24	27	18	21	14	15	ns
tpd	Delay	Low Voltage Digital Input to PP 1x	38	241	26	164	18	104	ns
tpd	Delay	Digital input to NMOS 1x	--	24	--	18	--	13	ns

**Auto AEC-Q100 Qualified GreenPAK Programmable Mixed-Signal Matrix**
**Table 12: Typical Delay Estimated for Each Macrocell at T<sub>A</sub> = 25 °C(Continued)**

Parameter	Description	Note	V <sub>DD</sub> = 2.5 V		V <sub>DD</sub> = 3.3 V		V <sub>DD</sub> = 5 V		Unit
			Rising	Falling	Rising	Falling	Rising	Falling	
tpd	Delay	Digital input to NMOS 2x	--	23	--	17	--	13	ns
tpd	Delay	Digital input to NMOS 4x	--	23	--	17	--	13	ns
tpd	Delay	Output enable from Pin, OE Hi-Z to 1	23	--	16	--	12	--	ns
tpd	Delay	Output enable from Pin, OE Hi-Z to 0	--	22	--	16	--	12	ns
tpd	Delay	PP 1x 3 State Hi-Z to 1	22	--	16	--	12	--	ns
tpd	Delay	PP 1x 3 State Hi-Z to 0	--	22	--	16	--	12	ns
tpd	Delay	PP 2x 3 State Hi-Z to 1	21	--	16	--	12	--	ns
tpd	Delay	PP 2x 3 State Hi-Z to 0	--	21	--	15	--	11	ns
tpd	Delay	LATCH Q	16	18	11	13	8	9	ns
tpd	Delay	LATCH nQ	19	15	14	11	9	7	ns
tpd	Delay	LATCH nRESET High Q	25	21	17	15	12	10	ns
tpd	Delay	LATCH nRESET High nQ	22	24	16	17	11	12	ns
tpd	Delay	LATCH nRESET Low Q	22	23	15	16	11	12	ns
tpd	Delay	LATCH nRESET Low nQ	24	21	17	15	12	10	ns
tpd	Delay	LATCH nSET High Q	19	21	14	15	9	10	ns
tpd	Delay	LATCH nSET High nQ	22	19	16	13	11	9	ns
tpd	Delay	LATCH nSET Low Q	22	18	16	13	11	9	ns
tpd	Delay	LATCH nSET Low nQ	19	21	14	15	9	10	ns
tpd	Delay	Multi-Function LATCH Q	19	22	14	16	9	11	ns
tpd	Delay	Multi-Function LATCH nQ	22	19	16	13	11	9	ns
tpd	Delay	Multi-Function LATCH nRESET Q	23	27	16	19	11	14	ns
tpd	Delay	Multi-Function LATCH nRESET nQ	27	23	20	17	14	11	ns
tpd	Delay	Multi-Function LATCH nSET Q	25	21	18	15	13	10	ns
tpd	Delay	Multi-Function LATCH nSET nQ	21	25	15	18	10	13	ns
tpd	Delay	LATCH3, LATCH12 First Q	17	19	12	14	8	9	ns
tpd	Delay	LATCH3, LATCH12 First nQ	20	17	14	12	10	8	ns
tpd	Delay	LATCH3, LATCH12 First nRESET High Q	26	23	18	16	13	11	ns
tpd	Delay	LATCH3, LATCH12 First nRESET High nQ	24	26	17	18	12	13	ns
tpd	Delay	LATCH3, LATCH12 First nRESET Low Q	23	25	16	18	11	12	ns
tpd	Delay	LATCH3, LATCH12 First nRESET Low nQ	26	23	18	16	13	11	ns
tpd	Delay	LATCH3, LATCH12 First nSET High Q	21	22	15	16	10	11	ns
tpd	Delay	LATCH3, LATCH12 First nSET High nQ	23	20	17	14	12	10	ns
tpd	Delay	LATCH3, LATCH12 First nSET Low Q	23	20	16	14	11	10	ns
tpd	Delay	LATCH3, LATCH12 First nSET Low nQ	21	23	15	16	10	11	ns
tpd	Delay	LATCH3, LATCH12 Second Q	19	19	13	13	9	9	ns
tpd	Delay	LATCH3, LATCH12 Second nQ	20	18	14	13	10	9	ns
tpd	Delay	LATCH3, LATCH12 Second nRESET High Q	--	22	--	16	--	11	ns

**Auto AEC-Q100 Qualified GreenPAK Programmable Mixed-Signal Matrix**
**Table 12: Typical Delay Estimated for Each Macrocell at T<sub>A</sub> = 25 °C(Continued)**

Parameter	Description	Note	V <sub>DD</sub> = 2.5 V		V <sub>DD</sub> = 3.3 V		V <sub>DD</sub> = 5 V		Unit
			Rising	Falling	Rising	Falling	Rising	Falling	
tpd	Delay	LATCH3, LATCH12 Second nRESET High nQ	23	--	17	--	12	--	ns
tpd	Delay	LATCH3, LATCH12 Second nRESET Low Q	--	25	--	18	--	12	ns
tpd	Delay	LATCH3, LATCH12 Second nRESET Low nQ	26	--	18	--	13	--	ns
tpd	Delay	LATCH3, LATCH12 Second nSET High Q	20	--	14	--	10	--	ns
tpd	Delay	LATCH3, LATCH12 Second nSET High nQ	--	20	--	14	--	10	ns
tpd	Delay	LATCH3, LATCH12 Second nSET Low Q	23	--	16	--	11	--	ns
tpd	Delay	LATCH3, LATCH12 Second nSET Low nQ	--	22	--	16	--	11	ns
tpd	Delay	2-bit LUT	15	16	11	11	7	8	ns
tpd	Delay	3-bit LUT	16	17	11	12	8	8	ns
tpd	Delay	4-bit LUT	19	17	13	12	9	9	ns
tpd	Delay	Multi-Function 3-bit LUT	18	21	13	15	9	11	ns
tpd	Delay	Multi-Function 3-bit LUT, CNT Delay	46	47	33	34	23	24	ns
tpd	Delay	Multi-Function 4-bit LUT	21	23	15	17	10	12	ns
tpd	Delay	Multi-Function 4-bit LUT, CNT Delay	48	46	34	34	23	24	ns
tpd	Delay	Edge detect	19	20	13	14	9	9	ns
tw	Width	Edge detect	211	212	156	157	115	115	ns
tpd	Delay	Edge detect Delayed	231	235	170	173	124	126	ns
tpd	Delay	Ripple CNT CLK DOWN Q0	18	16	13	11	9	8	ns
tpd	Delay	Ripple CNT CLK DOWN Q1	29	22	20	16	14	11	ns
tpd	Delay	Ripple CNT CLK DOWN Q2	27	29	20	21	14	14	ns
tpd	Delay	Ripple CNT CLK UP Q0	18	16	13	11	9	8	ns
tpd	Delay	Ripple CNT CLK UP Q1	24	24	17	17	12	12	ns
tpd	Delay	Ripple CNT CLK UP Q2	29	23	21	17	15	12	ns
tpd	Delay	Ripple CNT nSET DOWN Q0	26	33	19	23	14	16	ns
tpd	Delay	Ripple CNT nSET DOWN Q1	26	41	19	29	13	21	ns
tpd	Delay	Ripple CNT nSET DOWN Q2	25	41	18	29	13	20	ns
tpd	Delay	Ripple CNT nSET UP Q0	26	33	19	23	14	16	ns
tpd	Delay	Ripple CNT nSET UP Q1	26	38	19	27	13	19	ns
tpd	Delay	Ripple CNT nSET UP Q2	25	44	18	32	13	22	ns
tpd	Delay	DFF Q	17	17	12	12	8	8	ns
tpd	Delay	DFF nQ	18	16	13	11	9	8	ns
tpd	Delay	DFF nRESET High Q	--	20	--	14	--	10	ns
tpd	Delay	DFF nRESET High nQ	21	--	15	--	10	--	ns
tpd	Delay	DFF nRESET Low Q	--	22	--	16	--	11	ns
tpd	Delay	DFF nRESET Low nQ	23	--	17	--	12	--	ns
tpd	Delay	DFF nSET High Q	21	--	15	--	10	--	ns

**Auto AEC-Q100 Qualified GreenPAK Programmable Mixed-Signal Matrix**
**Table 12: Typical Delay Estimated for Each Macrocell at T<sub>A</sub> = 25 °C(Continued)**

Parameter	Description	Note	V <sub>DD</sub> = 2.5 V		V <sub>DD</sub> = 3.3 V		V <sub>DD</sub> = 5 V		Unit
			Rising	Falling	Rising	Falling	Rising	Falling	
tpd	Delay	DFF nSET High nQ	--	20	--	14	--	10	ns
tpd	Delay	DFF nSET Low Q	23	--	16	--	12	--	ns
tpd	Delay	DFF nSET Low nQ	--	22	--	16	--	11	ns
tpd	Delay	Multi-Function DFF Q	19	19	13	13	9	9	ns
tpd	Delay	Multi-Function DFF nQ	20	19	14	13	9	9	ns
tpd	Delay	Multi-Function DFF nRESET Q	--	26	--	19	--	13	ns
tpd	Delay	Multi-Function DFF nRESET nQ	26	--	19	--	13	--	ns
tpd	Delay	Multi-Function DFF nSET Q	26	--	19	--	13	--	ns
tpd	Delay	Multi-Function DFF nSET nQ	--	26	--	19	--	14	ns
tpd	Delay	DFF3, DFF12 First Q	18	18	13	13	9	9	ns
tpd	Delay	DFF3, DFF12 First nQ	19	18	14	13	9	9	ns
tpd	Delay	DFF3, DFF12 First nRESET High Q	--	22	--	15	--	11	ns
tpd	Delay	DFF3, DFF12 First nRESET High nQ	22	--	16	--	11	--	ns
tpd	Delay	DFF3, DFF12 First nRESET Low Q	--	24	--	17	--	12	ns
tpd	Delay	DFF3, DFF12 First nRESET Low nQ	25	--	18	--	12	--	ns
tpd	Delay	DFF3, DFF12 First nSET High Q	22	--	16	--	11	--	ns
tpd	Delay	DFF3, DFF12 First nSET High nQ	--	22	--	15	--	11	ns
tpd	Delay	DFF3, DFF12 First nSET Low Q	24	--	17	--	12	--	ns
tpd	Delay	DFF3, DFF12 First nSET Low nQ	--	24	--	17	--	12	ns
tpd	Delay	DFF3, DFF12 Second Q	20	21	14	15	10	10	ns
tpd	Delay	DFF3, DFF12 Second nQ	21	20	15	14	11	10	ns
tpd	Delay	DFF3, DFF12 Second nRESET High Q	--	21	--	15	--	10	ns
tpd	Delay	DFF3, DFF12 Second nRESET High nQ	22	--	16	--	11	--	ns
tpd	Delay	DFF3, DFF12 Second nRESET Low Q	--	23	--	17	--	12	ns
tpd	Delay	DFF3, DFF12 Second nRESET Low nQ	24	--	17	--	12	--	ns
tpd	Delay	DFF3, DFF12 Second nSET High Q	22	--	15	--	11	--	ns
tpd	Delay	DFF3, DFF12 Second nSET High nQ	--	21	--	15	--	10	ns
tpd	Delay	DFF3, DFF12 Second nSET Low Q	24	--	17	--	12	--	ns
tpd	Delay	DFF3, DFF12 Second nSET Low nQ	--	23	--	17	--	12	ns
tpd	Delay	PGen CLK	16	16	12	11	8	8	ns
tpd	Delay	PGen nRESET Hi-Z to 0	--	21	--	15	--	11	ns
tpd	Delay	PGen nRESET Hi-Z to 1	20	--	14	--	10	--	ns
tpd	Delay	Pipe Delay Out	23	20	16	15	11	10	ns
tpd	Delay	Pipe Delay nRESET Out	30	28	22	21	16	15	ns
tpd	Delay	Filter Q	160	140	109	98	68	65	ns
tpd	Delay	Filter nQ	141	159	99	108	66	68	ns

**Auto AEC-Q100 Qualified GreenPAK Programmable Mixed-Signal Matrix**
**Table 13: Typical Propagations Delays and Pulse Widths at T<sub>A</sub> = 25 °C**

Parameter	Description	Note	V <sub>DD</sub> = 2.5 V	V <sub>DD</sub> = 3.3V	V <sub>DD</sub> = 5.0V	Unit
tw	Pulse Width, 1 cell	mode: (any)edge detect, edge detect output	221	163	119	ns
tw	Pulse Width, 2 cell	mode: (any)edge detect, edge detect output	438	322	234	ns
tw	Pulse Width, 3 cell	mode: (any)edge detect, edge detect output	652	480	349	ns
tw	Pulse Width, 4 cell	mode: (any)edge detect, edge detect output	869	639	464	ns
time1	Delay, 1 cell	mode: (any)edge detect, edge detect output	18	13	9	ns
time1	Delay, 2 cell	mode: (any)edge detect, edge detect output	18	13	9	ns
time1	Delay, 3 cell	mode: (any)edge detect, edge detect output	18	13	9	ns
time1	Delay, 4 cell	mode: (any)edge detect, edge detect output	18	13	9	ns
time2	Delay, 1 cell	mode: both edge delay, edge detect output	240	176	128	ns
time2	Delay, 2 cell	mode: both edge delay, edge detect output	455	334	243	ns
time2	Delay, 3 cell	mode: both edge delay, edge detect output	672	493	358	ns
time2	Delay, 4 cell	mode: both edge delay, edge detect output	888	673	473	ns

**Table 14: Typical Filter Rejection Pulse Width at T<sub>A</sub> = 25 °C**

Parameter	V <sub>DD</sub> = 2.5 V	V <sub>DD</sub> = 3.3V	V <sub>DD</sub> = 5.0V	Unit
Filtered Pulse Width	< 127	< 86	< 54	ns
Inverter Filtered Pulse Width	< 109	< 77	< 52	ns

**3.8 COUNTER/DELAY CHARACTERISTICS**
**Table 15: Typical Counter/Delay Offset at T<sub>A</sub> = 25 °C**

Parameter	OSC Freq	OSC Power	V <sub>DD</sub> = 2.5 V	V <sub>DD</sub> = 3.3 V	V <sub>DD</sub> = 5.0 V	Unit
Power-On time	25 MHz	auto	0.14	0.14	0.14	μs
Power-On time	2.048 MHz	auto	0.5	0.5	0.4	μs
Power-On time	2.048 kHz	auto	628	544	466	μs
frequency settling time	25 MHz	auto	4	4	8	μs
frequency settling time	2.048 MHz	auto	0.3	0.4	0.4	μs
frequency settling time	2.048 kHz	auto	660	570	480	μs
variable (CLK period)	25 MHz	forced	0-40	0-40	0-40	ns
variable (CLK period)	2.048 MHz	forced	0-0.5	0-0.5	0-0.5	μs
variable (CLK period)	2.048 kHz	forced	0-488	0-488	0-488	μs
tpd (non-delayed edge)	25 MHz/ 2.048 kHz	either	35	14	10	ns



# SLG46855-A

## Auto AEC-Q100 Qualified GreenPAK Programmable Mixed-Signal Matrix

### 3.9 OSCILLATOR CHARACTERISTICS

Table 16: Oscillators Frequency Limits,  $V_{DD} = 2.3\text{ V to }5.5\text{ V}$

OSC	Temperature Range					
	+25 °C			-40 °C to +105 °C		
	Minimum Value, kHz	Maximum Value, kHz	Error, %	Minimum Value, kHz	Maximum Value, kHz	Error, %
2.048 kHz OSC0	2.0150	2.0685	+1.00	1.7799	2.1085	+2.95
			-1.61			-13.09
2.048 MHz OSC1	2019.42	2068.48	+1.00	1947.519	2080.775	+1.60
			-1.40			-4.91
25 MHz OSC2	24623	25250	+1.00	23655	25369	+1.48
			-1.51			-5.38

#### 3.9.1 OSC Power-On Delay

Table 17: Oscillators Power-On Delay at  $T_A = -40\text{ °C to }+105\text{ °C}$ , OSC Power Setting: "Auto Power-On"

Power Supply Range ( $V_{DD}$ ) V	OSC0 2.048 kHz		OSC1 2.048 MHz		OSC2 25 MHz		OSC2 25 MHz Start with Delay	
	Typical Value, $\mu\text{s}$	Maximum Value, $\mu\text{s}$	Typical Value, ns	Maximum Value, ns	Typical Value, ns	Maximum Value, ns	Typical Value, ns	Maximum Value, ns
2.30	698.2	1063.8	527.6	562.7	44.9	61.2	144.5	166.0
2.50	663.6	993.6	505.5	542.8	39.7	53.9	142.5	164.9
3.00	601.9	866.9	471.0	510.7	31.2	42.1	140.3	164.8
3.30	576.1	812.0	457.7	498.1	28.0	37.8	139.8	165.4
3.60	555.7	768.3	447.3	487.7	25.5	34.6	139.6	166.2
4.00	533.8	721.1	436.0	475.7	23.1	31.8	139.6	167.2
5.00	492.0	637.1	415.6	454.1	19.2	26.9	139.9	170.1
5.50	468.7	598.1	408.3	446.4	18.0	26.2	139.9	171.3

### 3.10 ACMP CHARACTERISTICS

Table 18: ACMP Specifications at  $T_A = -40\text{ °C to }+105\text{ °C}$ ,  $V_{DD} = 2.3\text{ V to }5.5\text{ V}$  Unless Otherwise Noted

Parameter	Description	Note	Condition	Min	Typ	Max	Unit
$V_{ACMP}$	ACMP Input Voltage Range	Positive Input		0	--	$V_{DD}$	V
		Negative Input		0	--	$V_{DD}$	V
$V_{offset}$	ACMP Input Offset	ACMPxH $V_{HYS} = 0\text{ mV}$ , Gain = 1, $V_{ref} = 32\text{ mV to }2016\text{ mV}$		-6.4	--	6.4	mV
		ACMPxL $V_{HYS} = 0\text{ mV}$ , Gain = 1, $V_{ref} = 32\text{ mV to }2016\text{ mV}$		-4.6	--	5.3	mV

**Auto AEC-Q100 Qualified GreenPAK Programmable  
Mixed-Signal Matrix**
**Table 18: ACMP Specifications at  $T_A = -40\text{ }^\circ\text{C}$  to  $+105\text{ }^\circ\text{C}$ ,  $V_{DD} = 2.3\text{ V}$  to  $5.5\text{ V}$  Unless Otherwise Noted(Continued)**

Parameter	Description	Note	Condition	Min	Typ	Max	Unit
$t_{\text{start}}$	ACMP Startup Time	ACMP Power-On delay, Minimal required wake time for the "Wake and Sleep function", for ACMPxH		--	--	37	$\mu\text{s}$
		ACMP Power-On delay, Minimal required wake time for the "Wake and Sleep function", for ACMPxL		--	--	294	$\mu\text{s}$
$V_{\text{HYS}}$	ACMP0H, ACMP1H Built-in Hysteresis (Note 1)	$V_{\text{HYS}} = 32\text{ mV}$	$T = 25\text{ }^\circ\text{C}$	23.33	--	36.59	mV
		$V_{\text{HYS}} = 64\text{ mV}$	$T = 25\text{ }^\circ\text{C}$	55.78	--	68.38	mV
		$V_{\text{HYS}} = 192\text{ mV}$	$T = 25\text{ }^\circ\text{C}$	183.67	--	197.36	mV
		$V_{\text{HYS}} = 32\text{ mV}$		22.03	--	37.25	mV
		$V_{\text{HYS}} = 64\text{ mV}$		54.12	--	68.99	mV
		$V_{\text{HYS}} = 192\text{ mV}$		182.73	--	197.57	mV
	ACMP2L, ACMP3L Built-in Hysteresis (Note 1)	$V_{\text{HYS}} = 32\text{ mV}$	$T = 25\text{ }^\circ\text{C}$	26.96	--	36.84	mV
		$V_{\text{HYS}} = 64\text{ mV}$	$T = 25\text{ }^\circ\text{C}$	58.44	--	69.25	mV
		$V_{\text{HYS}} = 192\text{ mV}$	$T = 25\text{ }^\circ\text{C}$	186.18	--	198.18	mV
		$V_{\text{HYS}} = 32\text{ mV}$		25.01	--	36.82	mV
		$V_{\text{HYS}} = 64\text{ mV}$		57.87	--	69.19	mV
		$V_{\text{HYS}} = 192\text{ mV}$		184.78	--	198.36	mV
$R_{\text{sin}}$	Series Input Resistance	Gain = 1x		--	10	--	$\text{G}\Omega$
		Gain = 0.5x		--	2	--	$\text{M}\Omega$
		Gain = 0.33x		--	2	--	$\text{M}\Omega$
		Gain = 0.25x		--	2	--	$\text{M}\Omega$

**Auto AEC-Q100 Qualified GreenPAK Programmable Mixed-Signal Matrix**
**Table 18: ACMP Specifications at  $T_A = -40\text{ }^\circ\text{C}$  to  $+105\text{ }^\circ\text{C}$ ,  $V_{DD} = 2.3\text{ V}$  to  $5.5\text{ V}$  Unless Otherwise Noted(Continued)**

Parameter	Description	Note	Condition	Min	Typ	Max	Unit
PROP	Propagation Delay, Response Time for ACMP0H, ACMP1H	Gain = 1, Vref = 32 mV to 2016 mV, Overdrive = 10 mV	Low to High	--	1.85	13.55	$\mu\text{s}$
			High to Low	--	2.48	10.04	$\mu\text{s}$
		Gain = 1, Vref = 32 mV to 2016 mV, Overdrive = 100 mV	Low to High	--	0.54	2.03	$\mu\text{s}$
			High to Low	--	0.53	0.97	$\mu\text{s}$
		Gain = 1, T = 25 $^\circ\text{C}$ , Vref = 32 mV, Overdrive = 10 mV	Low to High	--	1.46	--	$\mu\text{s}$
			High to Low	--	1.75	--	$\mu\text{s}$
	Gain = 1, T = 25 $^\circ\text{C}$ , Vref = 32 mV, Overdrive = 100 mV	Low to High	--	0.55	--	$\mu\text{s}$	
		High to Low	--	0.53	--	$\mu\text{s}$	
	Propagation Delay, Response Time for ACMP2L, ACMP3L	Gain = 1, Vref = 32 mV to 2016 mV, Overdrive = 10 mV	Low to High	--	56.65	128.40	$\mu\text{s}$
			High to Low	--	63.01	141.48	$\mu\text{s}$
		Gain = 1, Vref = 32 mV to 2016 mV, Overdrive = 100 mV	Low to High	--	19.73	60.49	$\mu\text{s}$
			High to Low	--	19.33	60.93	$\mu\text{s}$
Gain = 1, T = 25 $^\circ\text{C}$ , Vref = 32 mV, Overdrive = 10 mV		Low to High	--	68.15	--	$\mu\text{s}$	
		High to Low	--	66.31	--	$\mu\text{s}$	
Gain = 1, T = 25 $^\circ\text{C}$ , Vref = 32 mV, Overdrive = 100 mV	Low to High	--	27.54	--	$\mu\text{s}$		
	High to Low	--	27.01	--	$\mu\text{s}$		
G	Gain error	G = 1, Vref = 32 mV		1	1	1	
		G = 0.5, Vref = 32 mV		0.484	0.502	0.526	
		G = 0.33, Vref = 32 mV		0.324	0.338	0.358	
		G = 0.25, Vref = 32 mV		0.238	0.250	0.263	
		G = 1, Vref = 480 mV		1	1	1	
		G = 0.5, Vref = 480 mV		0.497	0.501	0.504	
		G = 0.33, Vref = 480 mV		0.330	0.333	0.337	
		G = 0.25, Vref = 480 mV		0.248	0.250	0.253	
Vref	Internal Vref0 error Vref0 = 32 mV to 2016 mV, Buffer disabled	$V_{DD} = 4.0\text{ V}$	T = 25 $^\circ\text{C}$	-0.85	--	4.95	%
				Internal Vref0 error Vref0 = 320 mV to 2016 mV, Buffer enabled	$V_{DD} = 4.0\text{ V}$	T = 25 $^\circ\text{C}$ $I_{LOAD} = 1\text{ }\mu\text{A}$	-7.96
	$I_{LOAD} = 1\text{ }\mu\text{A}$	-8.66	--				2.39
	Internal Vref1 error Vref1 = 32 mV to 2016 mV, Buffer disabled	$V_{DD} = 4.0\text{ V}$	T = 25 $^\circ\text{C}$	-1.79	--	5.03	%
				Internal Vref1 error Vref1 = 320 mV to 2016 mV, Buffer enabled	$V_{DD} = 4.0\text{ V}$	T = 25 $^\circ\text{C}$ $I_{LOAD} = 1\text{ }\mu\text{A}$	-6.04
$I_{LOAD} = 1\text{ }\mu\text{A}$	-6.79	--	2.51				%

**Auto AEC-Q100 Qualified GreenPAK Programmable Mixed-Signal Matrix**
**Table 18: ACMP Specifications at  $T_A = -40\text{ }^\circ\text{C}$  to  $+105\text{ }^\circ\text{C}$ ,  $V_{DD} = 2.3\text{ V}$  to  $5.5\text{ V}$  Unless Otherwise Noted(Continued)**

Parameter	Description	Note	Condition	Min	Typ	Max	Unit
Is	Input Current Source		$V_{in} = V_{DD} - 0.7\text{ V}$ , $V_{DD} = 2.3\text{ V}$	23.3	94.1	117.7	$\mu\text{A}$
			$V_{in} = V_{DD} - 0.7\text{ V}$ , $V_{DD} = 2.5\text{ V}$	78.4	94.9	111.4	$\mu\text{A}$
			$V_{in} = V_{DD} - 0.7\text{ V}$ , $V_{DD} = 3.3\text{ V}$	78.2	95.3	111.8	$\mu\text{A}$
			$V_{in} = V_{DD} - 0.7\text{ V}$ , $V_{DD} = 4.0\text{ V}$	78.2	95.4	112.0	$\mu\text{A}$
			$V_{in} = V_{DD} - 0.7\text{ V}$ , $V_{DD} = 5.0\text{ V}$	79.4	96.5	112.9	$\mu\text{A}$
			$V_{in} = V_{DD} - 0.7\text{ V}$ , $V_{DD} = 5.5\text{ V}$	81.7	98.7	116.4	$\mu\text{A}$
<b>Note 1</b> $V_{IL} = V_{in} - V_{HYS}$ , $V_{IH} = V_{in}$ .							

## SLG46855-A

### Auto AEC-Q100 Qualified GreenPAK Programmable Mixed-Signal Matrix

#### 3.11 ANALOG TEMPERATURE SENSOR CHARACTERISTICS

Temperature Sensor typical nonlinearity  $\pm 0.72\%$  for output range 1 and  $\pm 0.42\%$  for output range 2 at  $V_{DD} = 2.3\text{ V}$  to  $5.5\text{ V}$ .

**Table 19: TS Output vs Temperature (Output Range 1),  $V_{DD} = 2.3\text{ V}$  to  $5.5\text{ V}$**

T, °C	Buffer Enabled			Buffer Disabled		
	Min, mV	Typ, mV	Max, mV	Min, mV	Typ, mV	Max, mV
-40	992	997	1004	992	997	1005
-20	947	952	960	947	952	960
0	902	907	914	902	907	914
20	856	861	868	856	861	868
25	844	849	856	844	849	856
40	809	814	821	808	814	821
60	761	767	775	761	766	775
80	713	719	727	713	719	727
100	664	670	679	664	670	679
105	652	658	667	652	658	667

**Table 20: TS Output vs Temperature (Output Range 2),  $V_{DD} = 2.3\text{ V}$  to  $5.5\text{ V}$**

T, °C	Buffer Enabled			Buffer Disabled		
	Min, mV	Typ, mV	Max, mV	Min, mV	Typ, mV	Max, mV
-40	1192	1204	1212	1193	1204	1213
-20	1143	1150	1158	1143	1150	1158
0	1088	1095	1103	1088	1095	1103
20	1033	1040	1048	1033	1040	1048
25	1019	1025	1034	1019	1025	1034
40	976	983	992	976	983	991
60	919	926	935	919	926	935
80	861	868	878	861	868	878
100	802	810	820	802	810	820
105	788	795	806	787	795	806

## SLG46855-A

### Auto AEC-Q100 Qualified GreenPAK Programmable Mixed-Signal Matrix

**Table 21: TS Output Error (Output Range 1),  $V_{DD} = 2.3\text{ V}$  to  $5.5\text{ V}$**

T, °C	Buffer Enabled		Buffer Disabled	
	Min, %	Max, %	Min, %	Max, %
-40	-0.56	0.70	-0.57	0.73
-20	-0.56	0.75	-0.56	0.76
0	-0.58	0.78	-0.58	0.78
20	-0.59	0.81	-0.59	0.80
25	-0.61	0.84	-0.61	0.84
40	-0.64	0.92	-0.65	0.92
60	-0.72	1.03	-0.73	1.06
80	-0.79	1.15	-0.79	1.17
100	-0.89	1.33	-0.90	1.33
105	-0.91	1.40	-0.91	1.35

**Table 22: TS Output Error (Output Range 2),  $V_{DD} = 2.3\text{ V}$  to  $5.5\text{ V}$**

T, °C	Buffer Enabled		Buffer Disabled	
	Min, %	Max, %	Min, %	Max, %
-40	-0.99	0.70	-0.96	0.71
-20	-0.58	0.72	-0.59	0.72
0	-0.60	0.76	-0.60	0.74
20	-0.63	0.78	-0.63	0.77
25	-0.64	0.80	-0.64	0.81
40	-0.67	0.89	-0.67	0.90
60	-0.73	1.00	-0.73	0.99
80	-0.82	1.12	-0.82	1.12
100	-0.93	1.28	-0.93	1.28
105	-0.97	1.31	-0.97	1.32

Auto AEC-Q100 Qualified GreenPAK Programmable Mixed-Signal Matrix

4 User Programmability

The SLG46855-A is a user programmable device with one time programmable (OTP) memory elements that are able to configure the connection matrix and macrocells. A programming development kit allows the user the ability to create initial devices. Once the design is finalized, the programming code (.gpx file) is forwarded to Renesas Electronics Corporation to integrate into a production process.

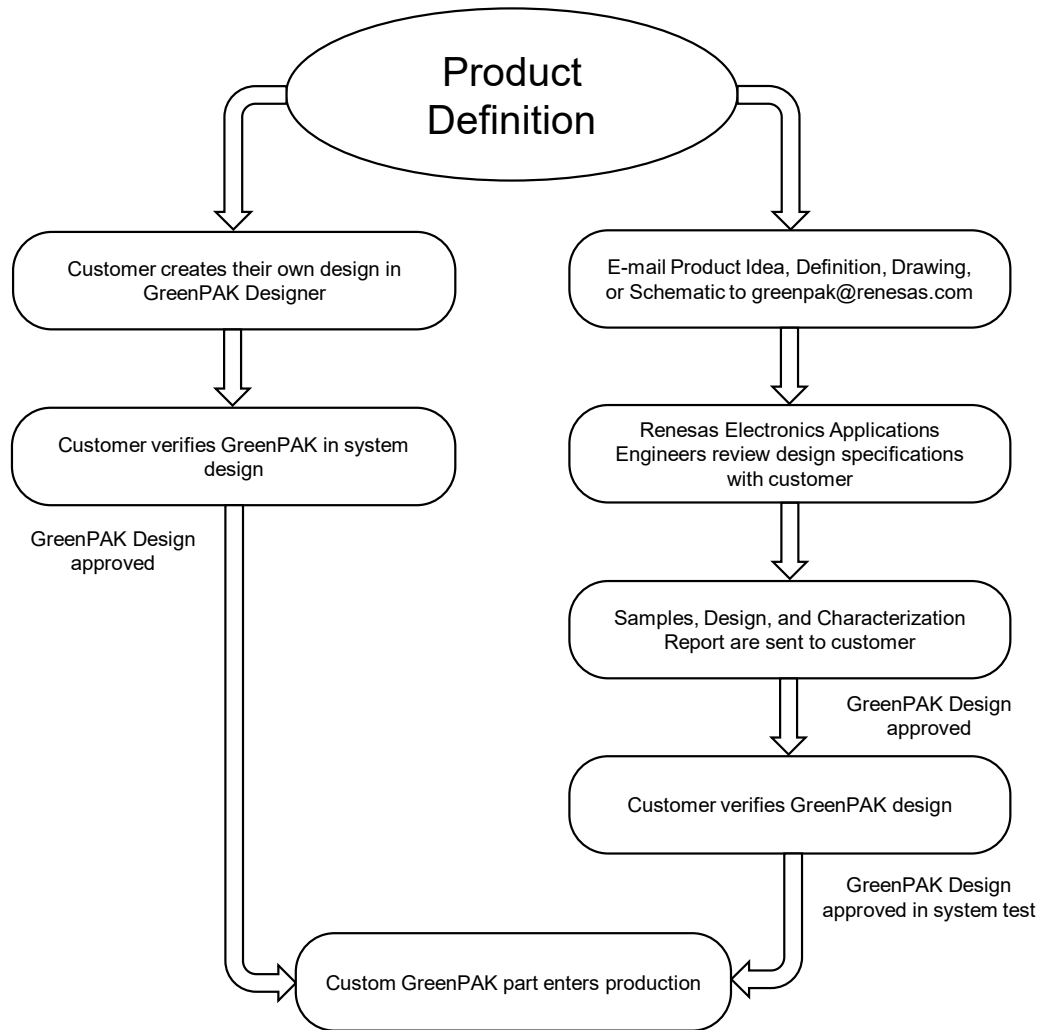

Figure 2: Steps to Create a Custom GreenPAK Device

## SLG46855-A

---

### Auto AEC-Q100 Qualified GreenPAK Programmable Mixed-Signal Matrix

#### 5 IO Pins

The SLG46855-A has a total of 10 GPIO, 1 GPI, and 1 GPO Pins which can function as either a user defined Input or Output, as well as serving as a special function (such as outputting the voltage reference).

##### 5.1 GPIO PINS

GPIO0, GPIO1, GPIO2, GPIO3, GPIO4, GPIO5, GPIO6, GPIO7, GPIO8 and GPIO9 serve as General Purpose IO Pins.

##### 5.2 GPI PINS

GPI0 serves as a General Purpose Input Pin.

##### 5.3 GPO PINS

GPO0 serves as a General Purpose Output Pin.

##### 5.4 PULL-UP/DOWN RESISTORS

All IO Pins have the option for user selectable resistors connected to the input structure. The selectable values on these resistors are 10 k $\Omega$ , 100 k $\Omega$ , and 1 M $\Omega$ . The internal resistors can be configured as either Pull-up or Pull-downs.

##### 5.5 FAST PULL-UP/DOWN DURING POWER-UP

During power-up, IO Pull-up/down resistance will switch to 2.6 k $\Omega$  initially and then it will switch to normal setting value. This function is enabled by register [778].



SLG46855-A

Auto AEC-Q100 Qualified GreenPAK Programmable Mixed-Signal Matrix

5.6 GPI STRUCTURE

5.6.1 GPI Structure (for GPIO)

Input Mode [1:0]  
 00: Digital In without Schmitt Trigger, wosmt\_en = 1, OE=0  
 01: Digital In with Schmitt Trigger, smt\_en = 1, OE = 0  
 10: Low Voltage Digital In mode, lv\_en = 1, OE = 0  
 11: Reserved

Note 1: OE cannot be selected by user  
 Note 2: OE is Matrix output, Digital In is Matrix input

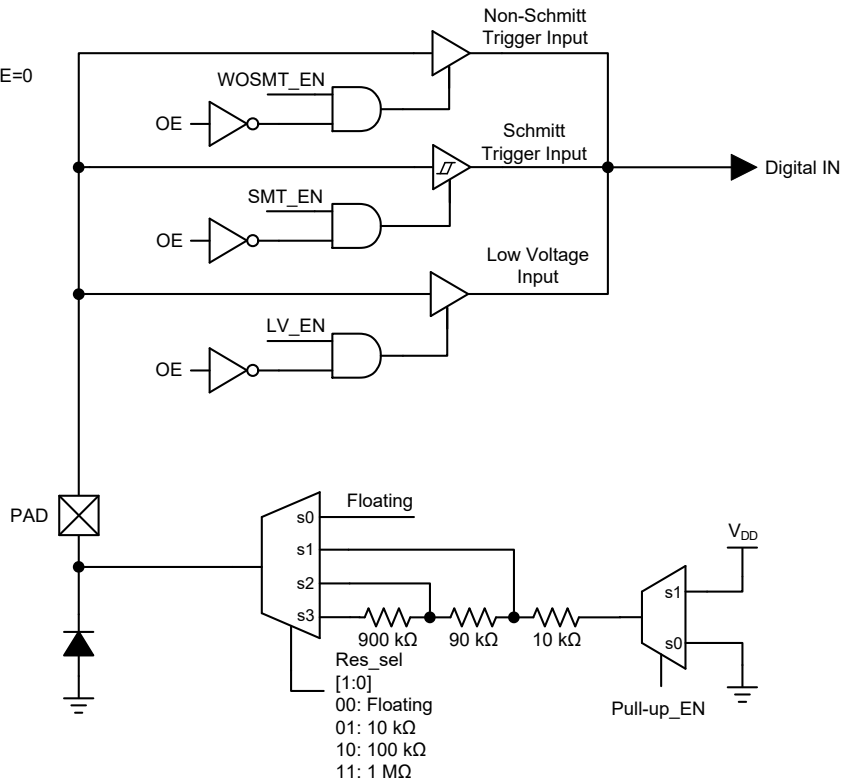

Figure 3: IO0 GPI Structure Diagram

SLG46855-A

Auto AEC-Q100 Qualified GreenPAK Programmable Mixed-Signal Matrix

5.7 GPIO WITH I<sup>2</sup>C MODE IO STRUCTURE

5.7.1 GPIO with I<sup>2</sup>C Mode Structure (for GPIO0 and GPIO1)

IO6, IO7 Mode [2:0]  
 00: Digital Input without Schmitt Trigger  
 01: Digital Input with Schmitt Trigger  
 10: Low Voltage Digital Input  
 11: Reserved

register [790]=1: Open-Drain NMOS for GPIO0  
 register [796]=1: Open-Drain NMOS for GPIO1

Note 1: OE cannot be selected by user and is controlled by register.  
 Digital In is Matrix input.  
 Note 2: GPIO0 and GPIO1 do not support Push-Pull and PMOS Open-Drain modes.  
 Note 3: It is possible to apply an input voltage higher than V<sub>DD</sub> to GPIO0 and GPIO1. However, this voltage should not exceed 5.5 V.  
 Note 4: Can be varied over PVT, for reference only

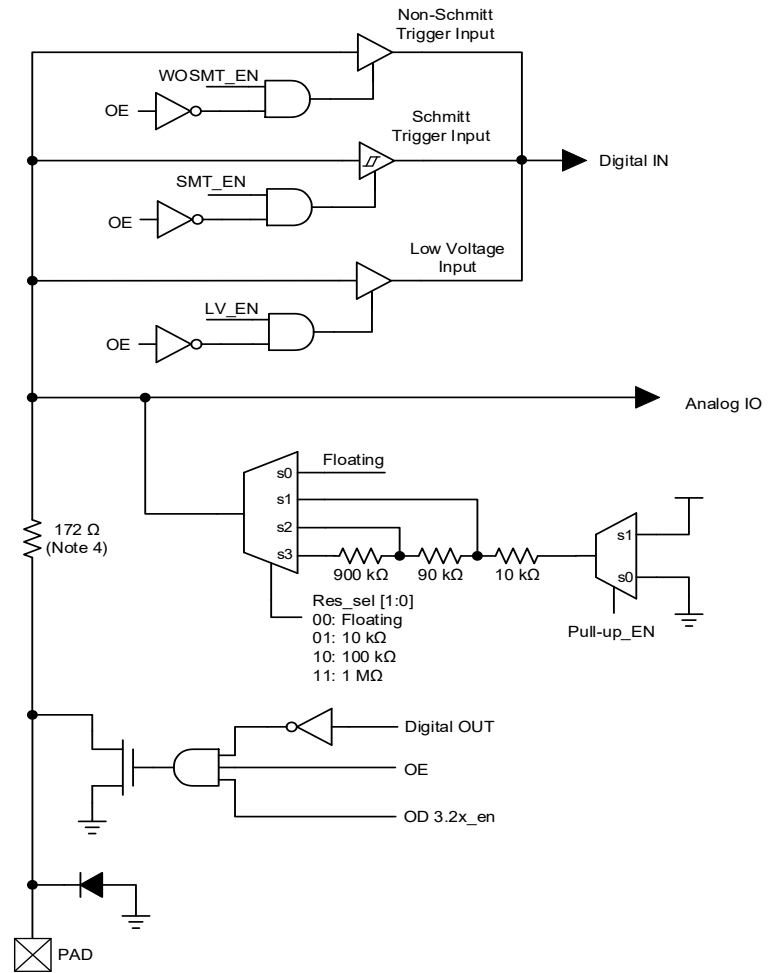

Figure 4: GPIO with I<sup>2</sup>C Mode IO Structure Diagram

SLG46855-A

Auto AEC-Q100 Qualified GreenPAK Programmable Mixed-Signal Matrix

5.8 MATRIX OE IO STRUCTURE

5.8.1 Matrix OE IO Structure (for GPIO2, GPIO3, GPIO5, GPIO6, GPIO7, GPIO8, and GPIO9)

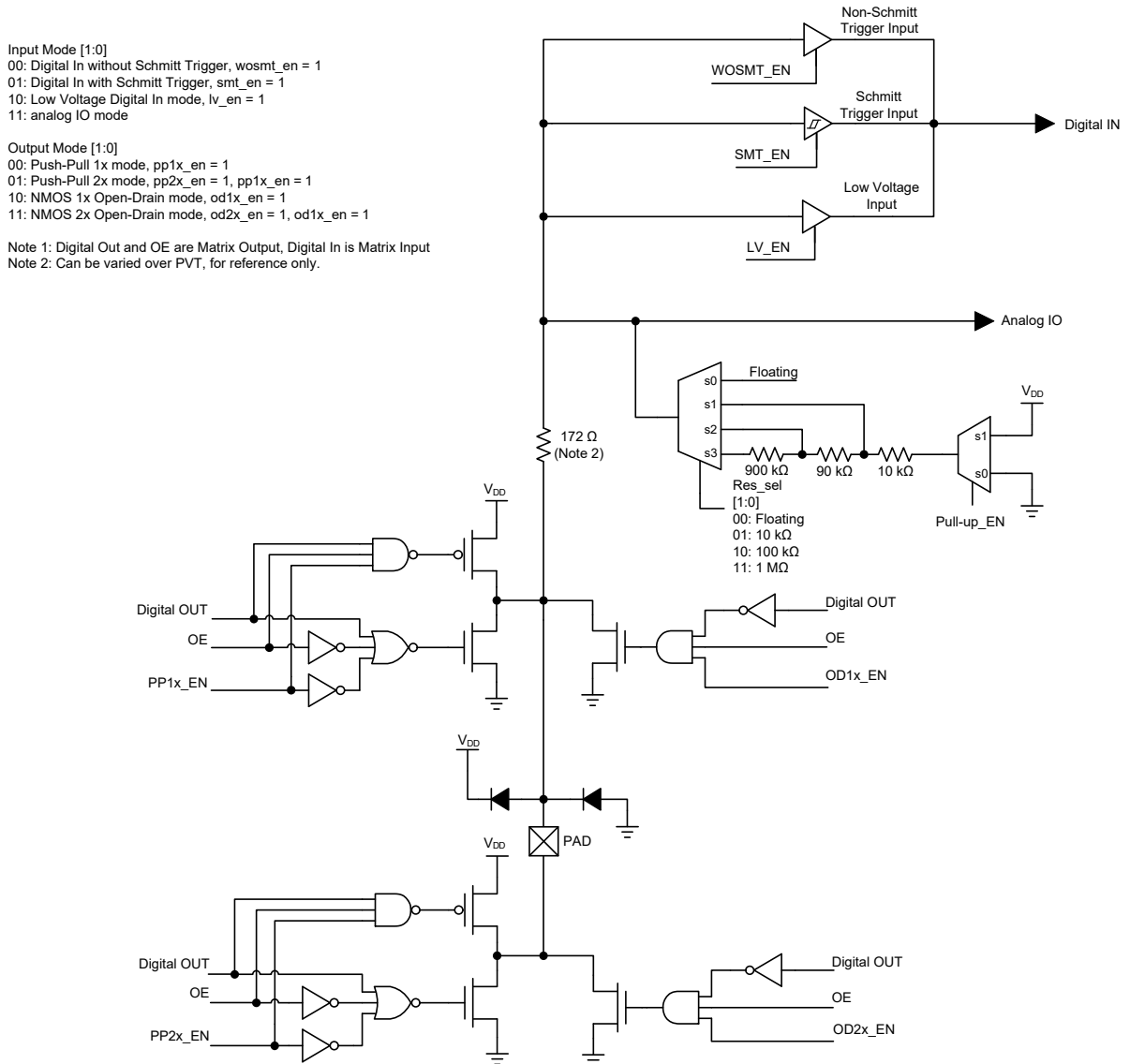

Figure 5: Matrix OE IO Structure Diagram

SLG46855-A

Auto AEC-Q100 Qualified GreenPAK Programmable Mixed-Signal Matrix

5.8.2 Matrix OE 4x Drive Structure (for GPIO4)

Input Mode [1:0]  
 00: Digital In without Schmitt Trigger, wosmt\_en = 1  
 01: Digital In with Schmitt Trigger, smt\_en = 1  
 10: Low Voltage Digital In mode, lv\_en = 1  
 11: Analog IO mode

Output Mode [2:0]  
 Registers [828], [824:823]  
 000: Push-Pull 1x mode (pp1x\_en)  
 001: Push-Pull 2x mode (pp2x\_en)  
 010: NMOS 1x Open-Drain mode (od1x\_en)  
 011: NMOS 2x Open-Drain mode (od2x\_en)  
 100: Reserved  
 101: Push-Pull 4x mode (pp4x\_en)  
 110: Reserved  
 111: NMOS 4x Open-Drain mode (od4x\_en)

Note 1: Digital Out and OE are Matrix output, Digital In is Matrix input  
 Note 2: Can be varied over PVT, for reference only

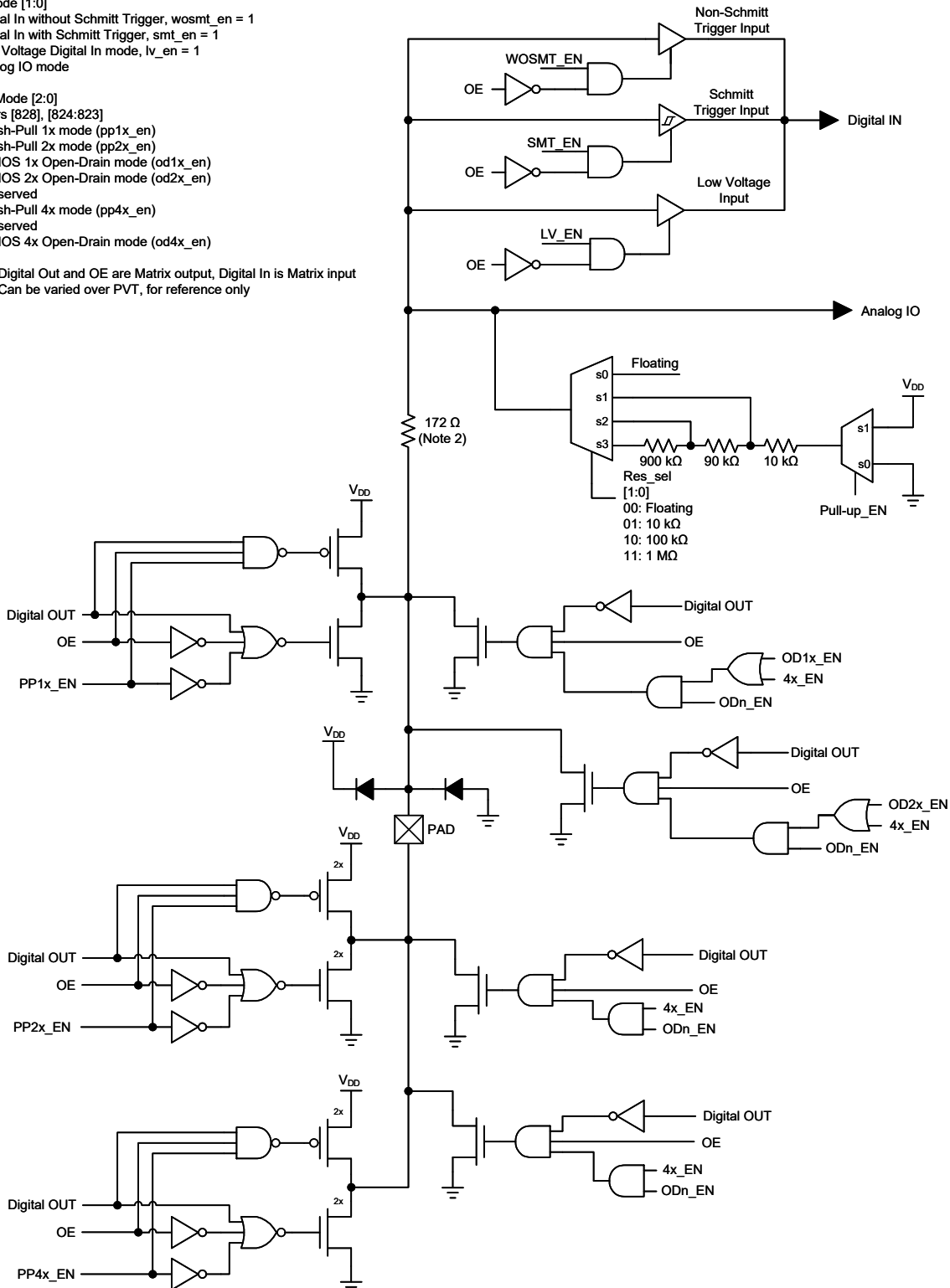

Figure 6: Matrix OE IO 4x Drive Structure Diagram

SLG46855-A

Auto AEC-Q100 Qualified GreenPAK Programmable Mixed-Signal Matrix

5.9 GPO STRUCTURE

5.9.1 GPO Register OE Structure (for GPO0)

Output Mode [2:0]  
 Registers [820], [815:814]  
 000: Push-Pull 1x mode (pp1x\_en)  
 001: Push-Pull 2x mode (pp2x\_en)  
 010: NMOS 1x Open-Drain mode (od1x\_en)  
 011: NMOS 2x Open-Drain mode (od2x\_en)  
 100: Reserved  
 101: Push-Pull 4x mode (pp4x\_en)  
 110: Reserved  
 111: NMOS 4x Open-Drain mode (od4x\_en)

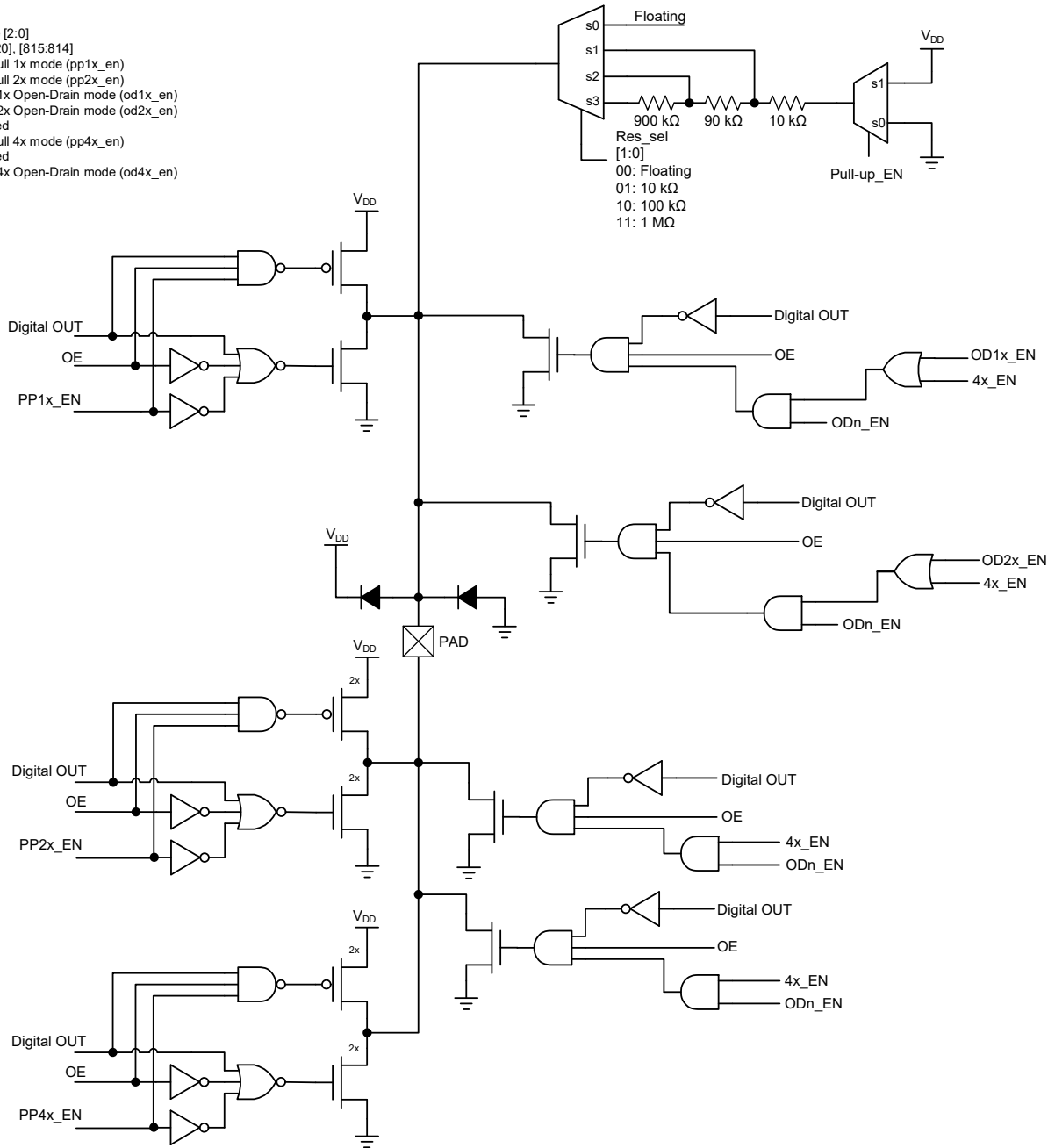

Figure 7: GPO Register OE 4x Drive Structure Diagram

SLG46855-A

Auto AEC-Q100 Qualified GreenPAK Programmable Mixed-Signal Matrix

5.10 IO TYPICAL PERFORMANCE

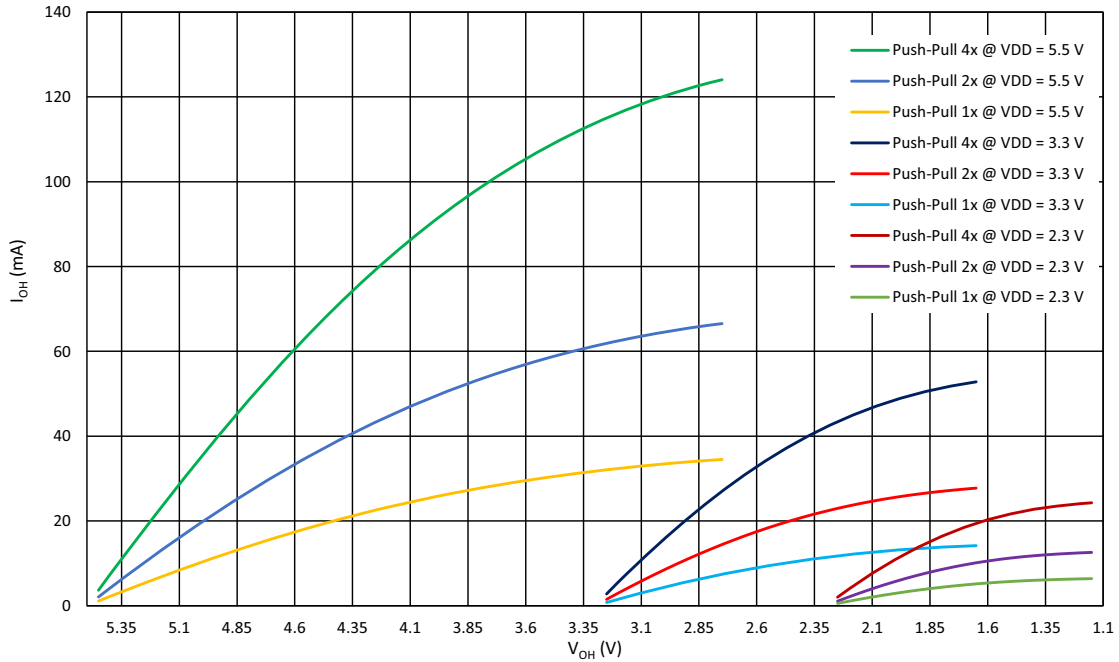

Figure 8: Typical High Level Output Current vs. High Level Output Voltage at T = 25 °C

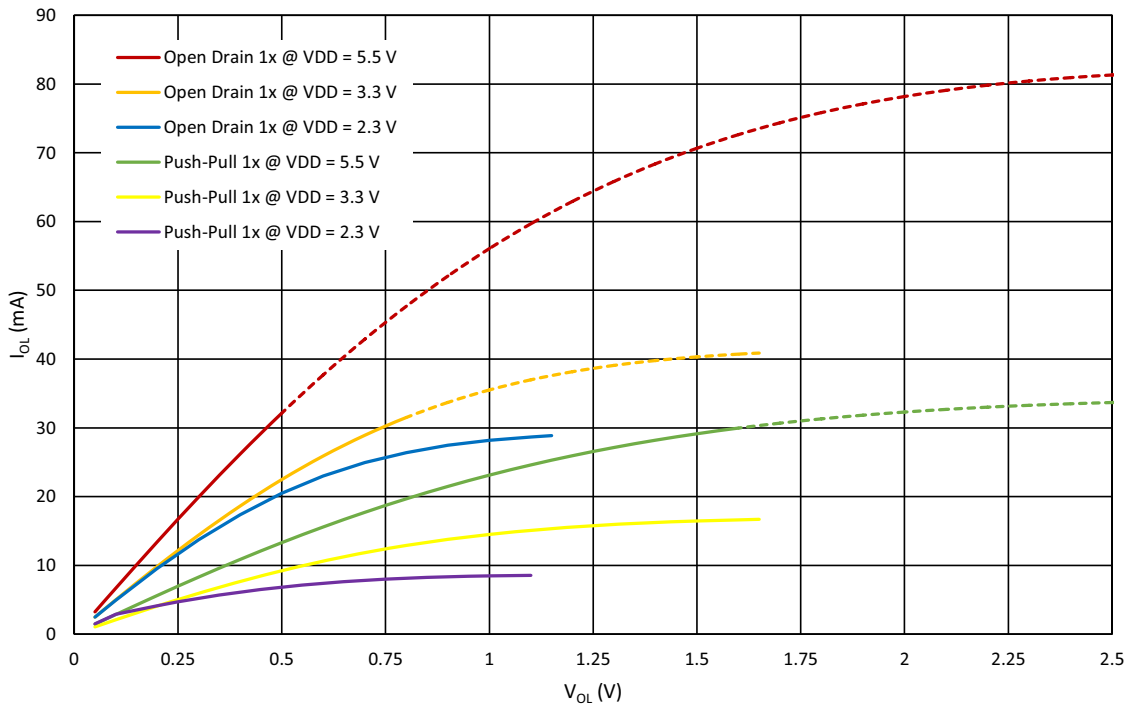

Figure 9: Typical Low Level Output Current vs. Low Level Output Voltage, 1x Drive at T = 25 °C, Full Range

SLG46855-A

Auto AEC-Q100 Qualified GreenPAK Programmable Mixed-Signal Matrix

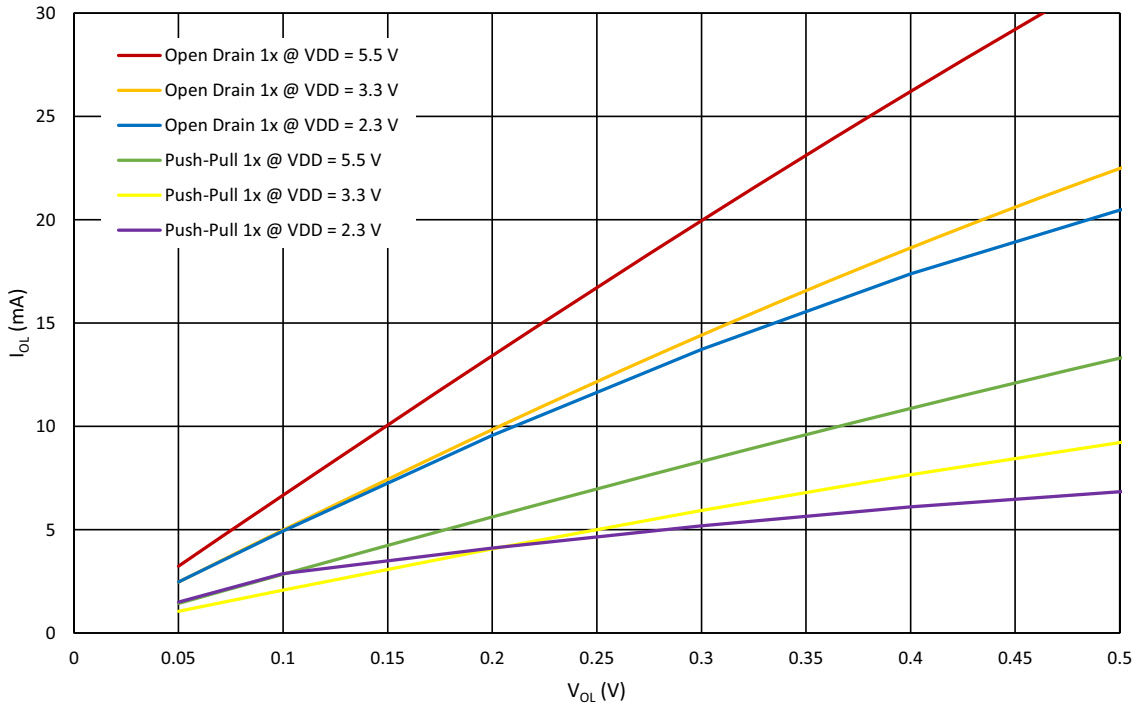

Figure 10: Typical Low Level Output Current vs. Low Level Output Voltage, 1x Drive at T = 25 °C

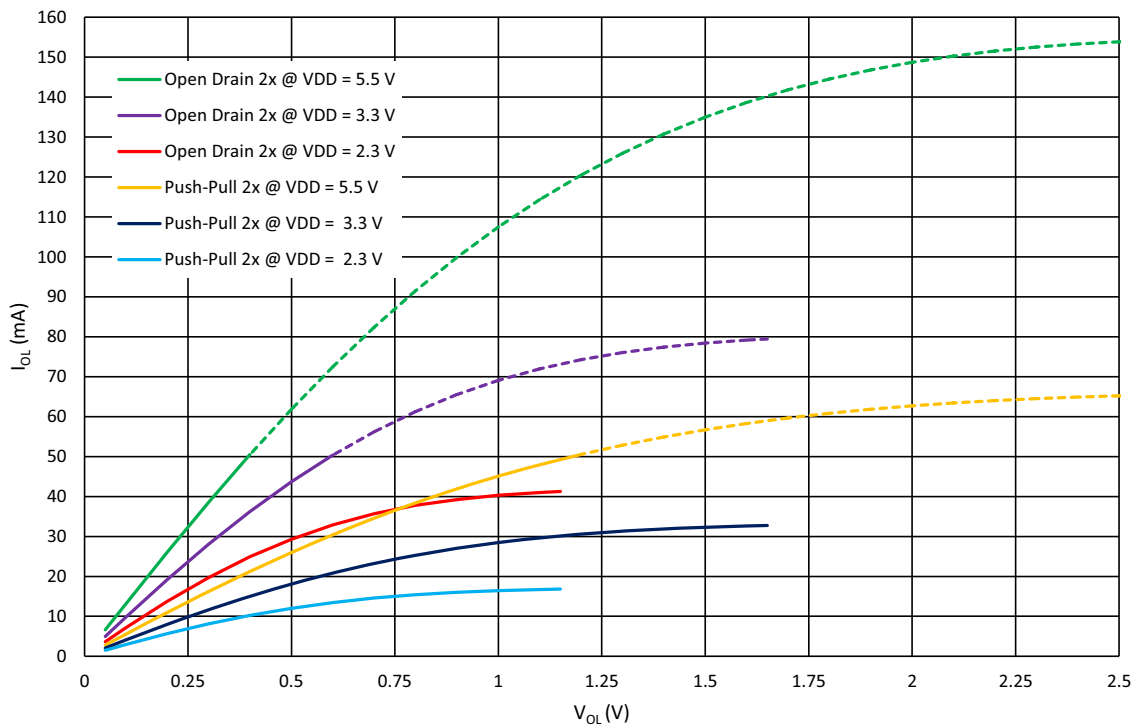

Figure 11: Typical Low Level Output Current vs. Low Level Output Voltage, 2x Drive at T = 25 °C, Full Range

SLG46855-A

Auto AEC-Q100 Qualified GreenPAK Programmable Mixed-Signal Matrix

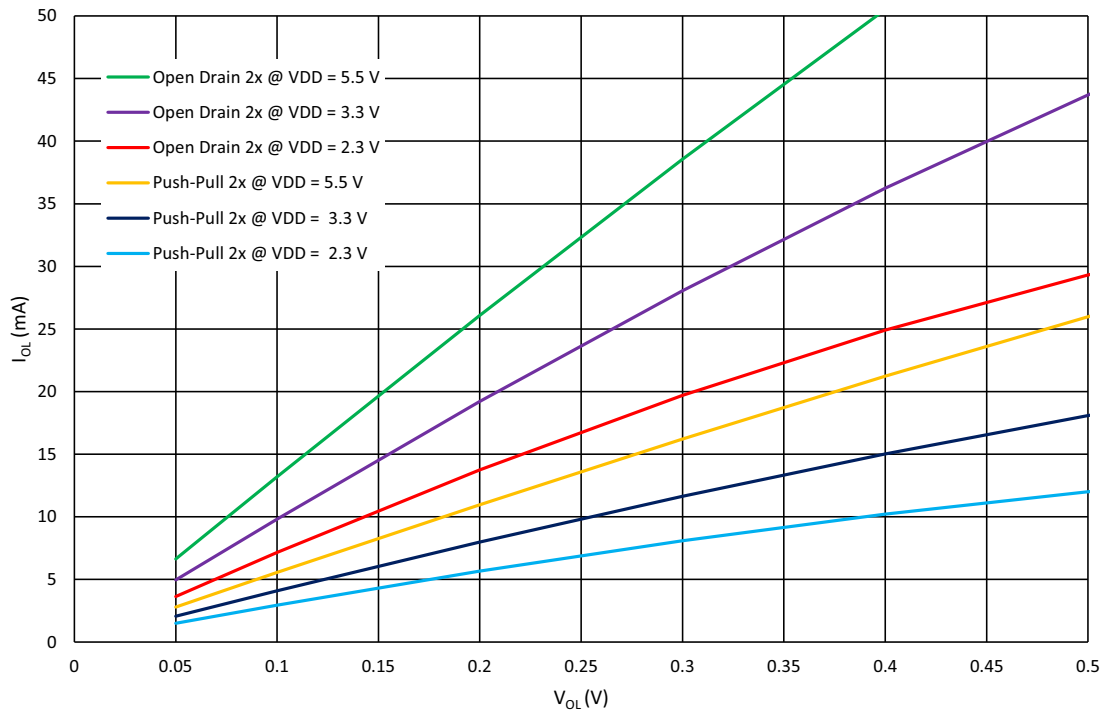

Figure 12: Typical Low Level Output Current vs. Low Level Output Voltage, 2x Drive at T = 25 °C

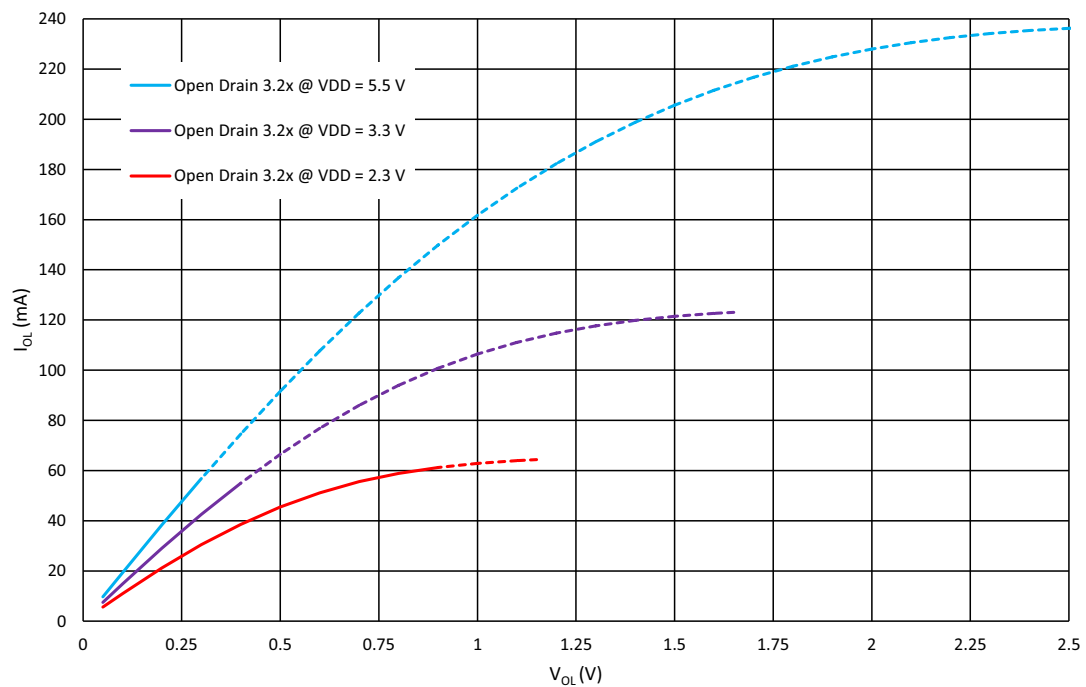

Figure 13: Typical Low Level Output Current vs. Low Level Output Voltage, 3.2x Drive at T = 25 °C, Full Range



SLG46855-A

Auto AEC-Q100 Qualified GreenPAK Programmable Mixed-Signal Matrix

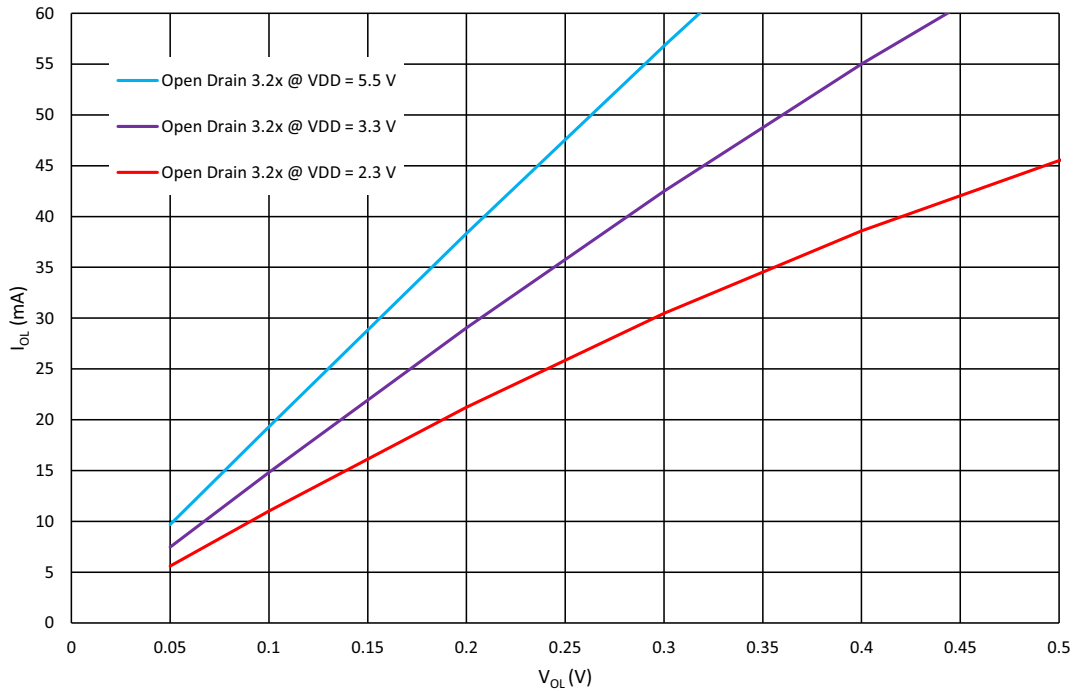

Figure 14: Typical Low Level Output Current vs. Low Level Output Voltage, 3.2x Drive at T = 25 °C

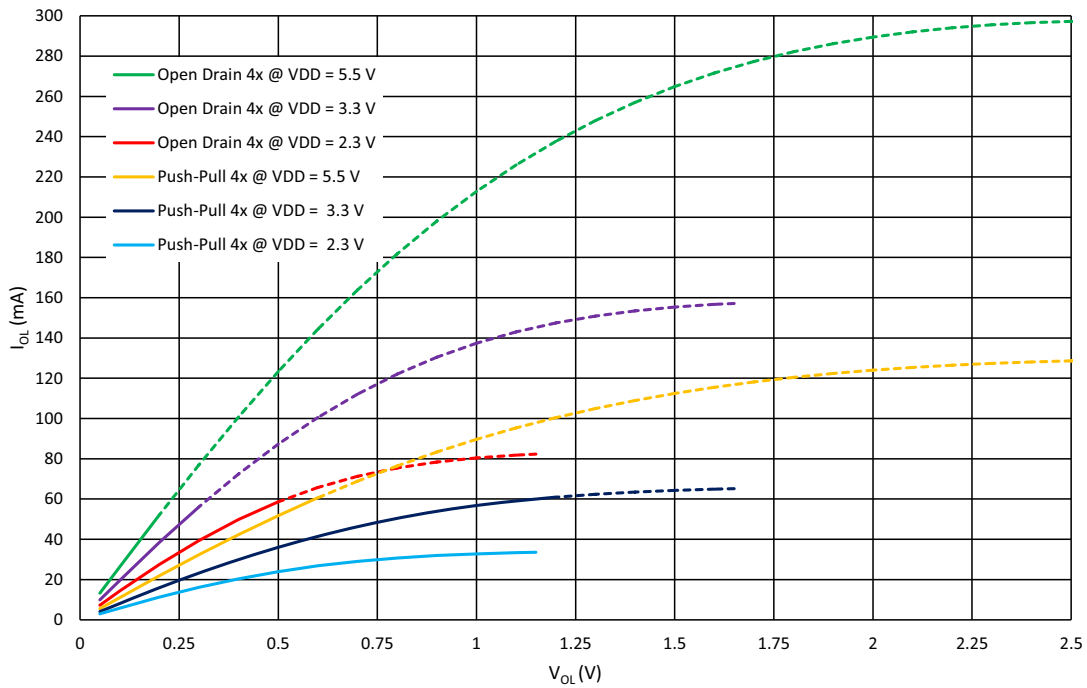

Figure 15: Typical Low Level Output Current vs. Low Level Output Voltage, 4x Drive at T = 25 °C, Full Range

SLG46855-A

Auto AEC-Q100 Qualified GreenPAK Programmable Mixed-Signal Matrix

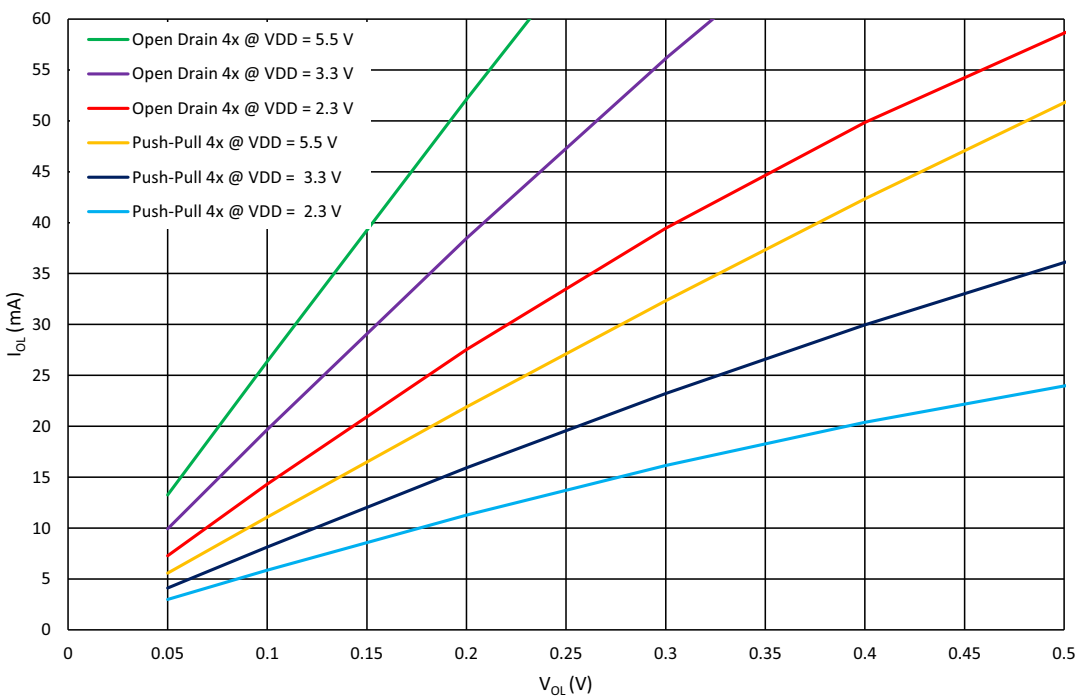

Figure 16: Typical Low Level Output Current vs. Low Level Output Voltage, 4x Drive at T = 25 °C

# SLG46855-A

## Auto AEC-Q100 Qualified GreenPAK Programmable Mixed-Signal Matrix

### 6 Connection Matrix

The Connection Matrix in the SLG46855-A is used to create the internal routing for internal functional macrocells of the device once it is programmed. The registers are programmed from the one time programmable (OTP) NVM cell during Test Mode Operation. The output of each functional macrocell within the SLG46855-A has a specific digital bit code assigned to it that is either set to active “High” or inactive “Low”, based on the design that is created. Once the 2048 register bits within the SLG46855-A are programmed a fully custom circuit will be created.

The Connection Matrix has 64 inputs and 96 outputs. Each of the 64 inputs to the Connection Matrix is hard-wired to the digital output of a particular source macrocell, including IO pins, LUTs, analog comparators, other digital resources, such as V<sub>DD</sub> and GND. The input to a digital macrocell uses a 6-bit register to select one of these 64 input lines.

For a complete list of the SLG46855-A's register table, see Section 17.

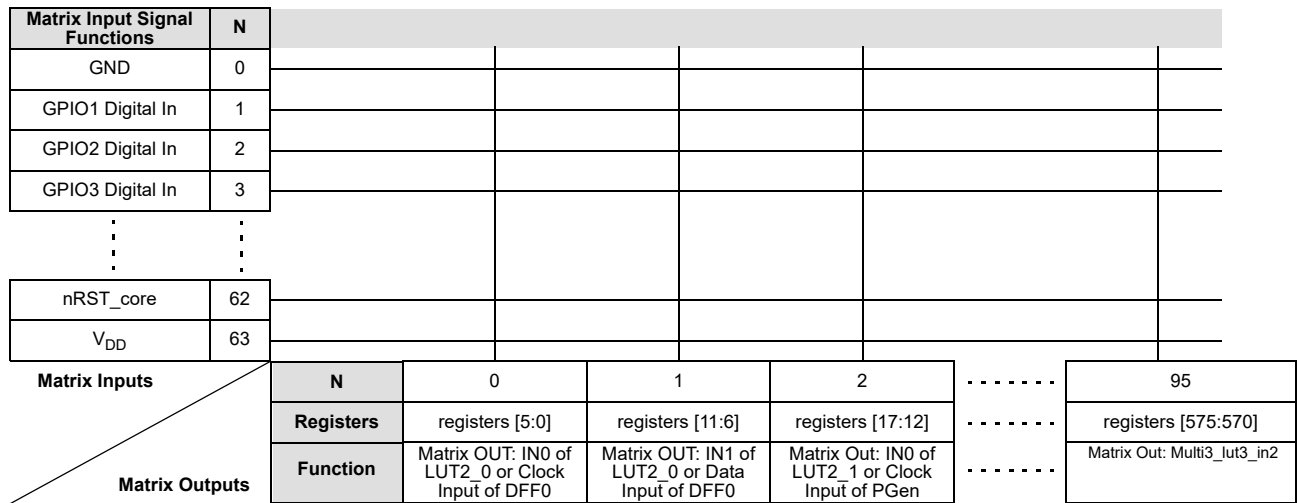

Figure 17: Connection Matrix

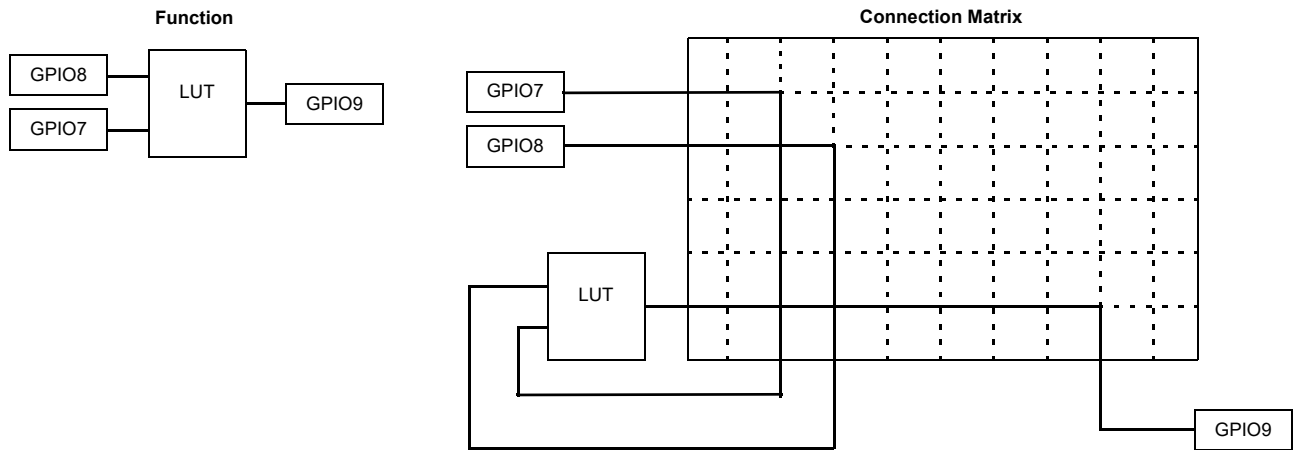

Figure 18: Connection Matrix Example

**Auto AEC-Q100 Qualified GreenPAK Programmable Mixed-Signal Matrix**
**6.1 MATRIX INPUT TABLE**
**Table 23: Matrix Input Table**

Matrix Input Number	Matrix Input Signal Function	Matrix Decode					
		5	4	3	2	1	0
0	GND	0	0	0	0	0	0
1	LUT2_0/DFF0 output	0	0	0	0	0	1
2	LUT2_1/DFF1 output	0	0	0	0	1	0
3	LUT2_2/DFF2 output	0	0	0	0	1	1
4	LUT2_3/PGen output	0	0	0	1	0	0
5	LUT3_0/DFF3 output	0	0	0	1	0	1
6	LUT3_1/DFF4 output	0	0	0	1	1	0
7	LUT3_2/DFF5 output	0	0	0	1	1	1
8	LUT3_3/DFF6 output	0	0	1	0	0	0
9	LUT3_4/DFF7 output	0	0	1	0	0	1
10	LUT3_5/DFF8 output	0	0	1	0	1	0
11	LUT3_6/DFF9 output	0	0	1	0	1	1
12	LUT3_7/DFF10 output	0	0	1	1	0	0
13	LUT3_8/DFF11 output	0	0	1	1	0	1
14	CNT0 output	0	0	1	1	1	0
15	MF0_LUT4/DFF_OUT	0	0	1	1	1	1
16	CNT1 output	0	1	0	0	0	0
17	MF1_LUT3/DFF_OUT	0	1	0	0	0	1
18	CNT2 output	0	1	0	0	1	0
19	MF2_LUT3/DFF_OUT	0	1	0	0	1	1
20	CNT3 output	0	1	0	1	0	0
21	MF3_LUT3/DFF_OUT	0	1	0	1	0	1
22	CNT4 output	0	1	0	1	1	0
23	MF4_LUT3/DFF_OUT	0	1	0	1	1	1
24	CNT5 output	0	1	1	0	0	0
25	MF5_LUT3/DFF_OUT	0	1	1	0	0	1
26	CNT6 output	0	1	1	0	1	0
27	MF6_LUT3/DFF_OUT	0	1	1	0	1	1
28	CNT7 output	0	1	1	1	0	0
29	MF7_LUT3/DFF_OUT	0	1	1	1	0	1
30	LUT3_16/Ripple CNT/Pipe Delay_out0	0	1	1	1	1	0
31	Ripple CNT/Pipe Delay_out1	0	1	1	1	1	1
32	GPIO0 digital input or I <sup>2</sup> C_virtual_0 Input	1	0	0	0	0	0
33	GPIO1 digital input or I <sup>2</sup> C_virtual_1 Input	1	0	0	0	0	1
34	I <sup>2</sup> C_virtual_2 Input	1	0	0	0	1	0
35	I <sup>2</sup> C_virtual_3 Input	1	0	0	0	1	1
36	I <sup>2</sup> C_virtual_4 Input	1	0	0	1	0	0
37	I <sup>2</sup> C_virtual_5 Input	1	0	0	1	0	1

**Auto AEC-Q100 Qualified GreenPAK Programmable Mixed-Signal Matrix**
**Table 23: Matrix Input Table(Continued)**

Matrix Input Number	Matrix Input Signal Function	Matrix Decode					
		5	4	3	2	1	0
38	I <sup>2</sup> C_virtual_6 Input	1	0	0	1	1	0
39	I <sup>2</sup> C_virtual_7 Input	1	0	0	1	1	1
40	Ripple CNT_out2	1	0	1	0	0	0
41	LUT4_0/DFF12 output	1	0	1	0	0	1
42	Programmable Delay Edge Detect Output	1	0	1	0	1	0
43	Edge Detect Filter Output	1	0	1	0	1	1
44	GPIO Digital Input	1	0	1	1	0	0
45	GPIO2 Digital Input	1	0	1	1	0	1
46	GPIO3, Digital Input	1	0	1	1	1	0
47	GPIO4 Digital Input	1	0	1	1	1	1
48	GPIO5 Digital Input	1	1	0	0	0	0
49	GPIO6 Digital Input	1	1	0	0	0	1
50	GPIO7 Digital Input	1	1	0	0	1	0
51	GPIO8 Digital Input	1	1	0	0	1	1
52	GPIO9, Digital Input	1	1	0	1	0	0
53	Oscillator0 output 0	1	1	0	1	0	1
54	Oscillator1 output 0	1	1	0	1	1	0
55	Oscillator2 output	1	1	0	1	1	1
56	ACMP0 Output (normal speed)	1	1	1	0	0	0
57	ACMP1 Output (normal speed)	1	1	1	0	0	1
58	ACMP2 Output (low speed)	1	1	1	0	1	0
59	ACMP3 output (low speed)	1	1	1	0	1	1
60	Oscillator0 output 1	1	1	1	1	0	0
61	Oscillator1 output 1	1	1	1	1	0	1
62	POR OUT	1	1	1	1	1	0
63	V <sub>DD</sub>	1	1	1	1	1	1

**Auto AEC-Q100 Qualified GreenPAK Programmable Mixed-Signal Matrix**
**6.2 MATRIX OUTPUT TABLE**
**Table 24: Matrix Output Table**

Register Bit Address	Matrix Output Signal Function	Matrix Output Number
[5:0]	IN0 of LUT2_0 or Clock Input of DFF0	0
[11:6]	IN1 of LUT2_0 or Data Input of DFF0	1
[17:12]	IN0 of LUT2_1 or Clock Input of DFF1	2
[23:18]	IN1 of LUT2_1 or Data Input of DFF1	3
[29:24]	IN0 of LUT2_2 or Clock Input of DFF2	4
[35:30]	IN1 of LUT2_2 or Data Input of DFF2	5
[41:36]	IN0 of LUT2_3 or Clock Input of PGen	6
[47:42]	IN1 of LUT2_3 or nRST of PGen	7
[53:48]	IN0 of LUT3_0 or CLK Input of DFF3	8
[59:54]	IN1 of LUT3_0 or Data of DFF3	9
[65:60]	IN2 of LUT3_0 or nRST (nSET) of DFF3	10
[71:66]	IN0 of LUT3_1 or CLK Input of DFF4	11
[77:72]	IN1 of LUT3_1 or Data of DFF4	12
[83:78]	IN2 of LUT3_1 or nRST (nSET) of DFF4	13
[89:84]	IN0 of LUT3_2 or CLK Input of DFF5	14
[95:90]	IN1 of LUT3_2 or Data of DFF5	15
[101:96]	IN2 of LUT3_2 or nRST (nSET) of DFF5	16
[107:102]	IN0 of LUT3_3 or CLK Input of DFF6	17
[113:108]	IN1 of LUT3_3 or Data of DFF6	18
[119:114]	IN2 of LUT3_3 or nRST (nSET) of DFF6	19
[125:120]	IN0 of LUT3_4 or CLK Input of DFF7	20
[131:126]	IN1 of LUT3_4 or Data of DFF7	21
[137:132]	IN2 of LUT3_4 or Data of DFF7	22
[143:138]	IN0 of LUT3_5 or CLK Input of DFF8	23
[149:144]	IN1 of LUT3_5 or Data of DFF8	24
[155:150]	IN2 of LUT3_5 or nRST (nSET) of DFF8	25
[161:156]	IN0 of LUT3_6 or CLK Input of DFF9	26
[167:162]	IN1 of LUT3_6 or Data of DFF9	27
[173:168]	IN2 of LUT3_6 or nRST (nSET) of DFF9	28
[179:174]	IN0 of LUT3_7 or CLK Input of DFF10	29
[185:180]	IN1 of LUT3_7 or Data of DFF10	30
[191:186]	IN2 of LUT3_7 or nRST (nSET) of DFF10	31
[197:192]	IN0 of LUT3_8 or CLK Input of DFF11	32
[203:198]	IN1 of LUT3_8 or CLK Input of DFF11	33
[209:204]	IN2 of LUT3_8 or nRST (nSET) of DFF11	34
[215:210]	IN0 of LUT3_12 or CLK Input of DFF16 Delay4 Input (or Counter4 nRST Input)	35
[221:216]	IN1 of LUT3_12 or nRST (nSET) of DFF16 Delay4 Input (or Counter4 nRST Input)	36

**Auto AEC-Q100 Qualified GreenPAK Programmable Mixed-Signal Matrix**
**Table 24: Matrix Output Table(Continued)**

Register Bit Address	Matrix Output Signal Function	Matrix Output Number
[227:222]	IN2 of LUT3_12 or Data of DFF16 Delay4 Input (or Counter4 nRST Input)	37
[233:228]	IN0 of LUT3_13 or CLK Input of DFF17 Delay5 Input (or Counter5 nRST Input)	38
[239:234]	IN1 of LUT3_13 or nRST (nSET) of DFF17 Delay5 Input (or Counter5 nRST Input)	39
[245:240]	IN2 of LUT3_13 or Data of DFF17 Delay5 Input (or Counter5 nRST Input)	40
[251:246]	IN0 of LUT3_14 or CLK Input of DFF18 Delay6 Input (or Counter6 nRST Input)	41
[257:252]	IN1 of LUT3_14 or nRST (nSET) of DFF18 Delay6 Input (or Counter6 nRST Input)	42
[263:258]	IN2 of LUT3_14 or Data of DFF18 Delay6 Input (or Counter6 nRST Input)	43
[269:264]	IN0 of LUT3_15 or CLK Input of DFF19 Delay7 Input (or Counter7 nRST Input)	44
[275:270]	IN1 of LUT3_15 or nRST (nSET) of DFF19 Delay7 Input (or Counter7 nRST Input)	45
[281:276]	IN2 of LUT3_15 or Data of DFF19 Delay7 Input (or Counter7 nRST Input)	46
[287:282]	IN0 of LUT3_16 or Input of Pipe Delay or UP signal of RIPP CNT	47
[293:288]	IN1 of LUT3_16 or nRST of Pipe Delay or nSET of RIPP CNT	48
[299:294]	IN2 of LUT3_16 or Clock of Pipe Delay_RIPP CNT	49
[305:300]	IN0 of LUT4_0 or CLK Input of DFF12	50
[311:306]	IN1 of LUT4_0 or Data of DFF12	51
[317:312]	IN2 of LUT4_0 or nRST (nSET) of DFF12	52
[323:318]	IN3 of LUT4_0	53
[329:324]	Programmable delay/edge detect input	54
[335:330]	Filter/Edge detect input	55
[341:336]	GPIO0 Digital Output	56
[347:342]	GPIO1 Digital Output	57
[353:348]	GPIO2 Digital Output	58
[359:354]	GPIO2 Digital Output OE	59
[365:360]	GPIO3, Digital Output	60
[371:366]	GPIO3, Digital Output OE	61
[377:372]	GPO0 Digital Output	62
[383:378]	GPIO4 Digital Output	63
[389:384]	GPIO4 Digital Output OE	64
[395:390]	GPIO5 Digital Output	65
[401:396]	GPIO5 Digital Output OE	66
[407:402]	GPIO6 Digital Output	67
[413:408]	GPIO6 Digital Output OE	68

**Auto AEC-Q100 Qualified GreenPAK Programmable Mixed-Signal Matrix**
**Table 24: Matrix Output Table(Continued)**

Register Bit Address	Matrix Output Signal Function	Matrix Output Number
[419:414]	GPIO7 Digital Output	69
[425:420]	GPIO7 Digital Output OE	70
[431:426]	GPIO8 Digital Output	71
[437:432]	GPIO8 Digital Output OE	72
[443:438]	GPIO9, Digital Output	73
[449:444]	GPIO9 Digital Output OE	74
[455:450]	PWR UP of ACMP0_H	75
[461:456]	PWR UP of ACMP1_H	76
[467:462]	PWR UP of ACMP2_L	77
[473:468]	PWR UP of ACMP3_L	78
[479:474]	Temp sensor, Vref Out_0, Vref Out_1 Power Up	79
[485:480]	Oscillator0 ENABLE	80
[491:486]	Oscillator1 ENABLE	81
[497:492]	Oscillator2 ENABLE	82
[503:498]	IN0 of LUT4_1 or CLK Input of DFF20 Delay0 Input (or Counter0 nRST Input)	83
[509:504]	IN1 of LUT4_1 or nRST of DFF20 Delay0 Input (or Counter0 nRST Input)	84
[515:510]	IN2 of LUT4_1 or nSET of DFF20 Delay0 Input (or Counter0 nRST Input)	85
[521:516]	IN3 of LUT4_1 or Data of DFF20 Delay0 Input (or Counter0 nRST Input)	86
[527:522]	IN0 of LUT3_9 or CLK Input of DFF13 Delay1 Input (or Counter1 nRST Input)	87
[533:528]	IN1 of LUT3_9 or nRST (nSET) of DFF13 Delay1 Input (or Counter1 nRST Input)	88
[539:523]	IN2 of LUT3_9 or Data of DFF13 Delay1 Input (or Counter1 nRST Input)	89
[545:540]	IN0 of LUT3_10 or CLK Input of DFF14 Delay2 Input (or Counter2 nRST Input)	90
[551:546]	IN1 of LUT3_10 or nRST (nSET) of DFF14 Delay2 Input (or Counter2 nRST Input)	91
[557:552]	IN2 of LUT3_10 or Data of DFF14 Delay2 Input (or Counter2 nRST Input)	92
[563:558]	IN0 of LUT3_11 or CLK Input of DFF15 Delay3 Input (or Counter3 nRST Input)	93
[569:564]	IN1 of LUT3_11 or nRST (nSET) of DFF15 Delay3 Input (or Counter3 nRST Input)	94
[575:570]	IN2 of LUT3_11 or Data of DFF15 Delay3 Input (or Counter3 nRST Input)	95
<b>Note 1</b> For each Address, the two most significant bits are unused.		



**Auto AEC-Q100 Qualified GreenPAK Programmable Mixed-Signal Matrix**
**6.3 CONNECTION MATRIX VIRTUAL INPUTS**

As mentioned previously, the Connection Matrix inputs come from the outputs of various digital macrocells on the device. Eight of the Connection Matrix inputs have the special characteristic that the state of these signal lines comes from a corresponding data bit written as a register value via I<sup>2</sup>C. This gives the user the ability to write data via the serial channel, and have this information translated into signals that can be driven into the Connection Matrix and from the Connection Matrix to the digital inputs of other macrocells on the device. The I<sup>2</sup>C address for reading and writing these register values is at byte 0x4C (076).

Six of the eight Connection Matrix Virtual Inputs are dedicated to this virtual input function. An I<sup>2</sup>C write command to these register bits will set the signal values going into the Connection Matrix to the desired state. A read command to these register bits will read either the original data values coming from the NVM memory bits (that were loaded during the initial device startup), or the values from a previous write command (if that has happened).

Two of the eight Connection Matrix Virtual Inputs are shared with Pin digital inputs (GPIO0Digital or I<sup>2</sup>C\_virtual\_0 Input), and (GPIO1 Digital or I<sup>2</sup>C\_virtual\_1 Input). If the virtual input mode is selected, an I<sup>2</sup>C write command to these register bits will set the signal values going into the Connection Matrix to the desired state. A read command to these register bits will read either the original data values coming from the NVM memory bits (that were loaded during the initial device startup), or the values from a previous write command (if that has happened). The I<sup>2</sup>C disable/enable register bit [2032] selects whether the Connection Matrix input comes from the Pin input or from the virtual register:

- Select SCL & Virtual Input 0 or GPIO0
- Select SDA & Virtual Input 1 or GPIO1

See [Table 24](#) for Connection Matrix Virtual Inputs.

**Table 25: Connection Matrix Virtual Inputs**

Matrix Input Number	Matrix Input Signal Function	Register Bit Addresses (d)
32	I <sup>2</sup> C_virtual_0 Input	[608]
33	I <sup>2</sup> C_virtual_1 Input	[609]
34	I <sup>2</sup> C_virtual_2 Input	[610]
35	I <sup>2</sup> C_virtual_3 Input	[611]
36	I <sup>2</sup> C_virtual_4 Input	[612]
37	I <sup>2</sup> C_virtual_5 Input	[613]
38	I <sup>2</sup> C_virtual_6 Input	[614]
39	I <sup>2</sup> C_virtual_7 Input	[615]

**6.4 CONNECTION MATRIX VIRTUAL OUTPUTS**

The digital outputs of the various macrocells are routed to the Connection Matrix to enable interconnections to the inputs of other macrocells in the device. At the same time, it is possible to read the state of each of the macrocell outputs as a register value via I<sup>2</sup>C. This option, called Connection Matrix Virtual Outputs, allows the user to remotely read the values of each macrocell output. The I<sup>2</sup>C addresses for reading these register values are bytes 0x48 (072) to 0x4F (079). Write commands to these same register values will be ignored (with the exception of the Virtual Input register bits at byte 0x4C (076)).

# SLG46855-A

## Auto AEC-Q100 Qualified GreenPAK Programmable Mixed-Signal Matrix

### 7 Combination Function Macrocells

The SLG46855-A has 15 combination function macrocells that can serve more than one logic or timing function. In each case, they can serve as a Look Up Table (LUT), or as another logic or timing function. See the list below for the functions that can be implemented in these macrocells.

- Three macrocells that can serve as either 2-bit LUT or as D Flip-Flop
- Nine macrocells that can serve as either 3-bit LUTs or as D Flip-Flops with Set/Reset Input
- One macrocell that can serve as either 3-bit LUT or as Pipe Delay/Ripple Counter
- One macrocell that can serve as either 2-bit LUT or as Programmable Pattern Generator (PGen)
- One macrocell that can serve as either 4-bit LUT or as D Flip-Flop with Set/Reset Input

Inputs/Outputs for the 15 combination function macrocells are configured from the connection matrix with specific logic functions being defined by the state of configuration bits.

When used as a LUT to implement combinatorial logic functions, the outputs of the LUTs can be configured to any user defined function, including the following standard digital logic devices (AND, NAND, OR, NOR, XOR, XNOR).

#### 7.1 2-BIT LUT OR D FLIP-FLOP MACROCELLS

There is one macrocell that can serve as either 2-bit LUT or as D Flip-Flop. When used to implement LUT functions, the 2-bit LUT takes in two input signals from the connection matrix and produce a single output, which goes back into the connection matrix. When used to implement D Flip-Flop function, the two input signals from the connection matrix go to the data (D) and clock (CLK) inputs for the Flip-Flop, with the output going back to the connection matrix.

The operation of the D Flip-Flop and LATCH will follow the functional descriptions below:

DFF: CLK is rising edge triggered, then Q = D; otherwise Q will not change

LATCH: when CLK is Low, then Q = D; otherwise Q remains its previous value (input D has no effect on the output, when CLK is High).

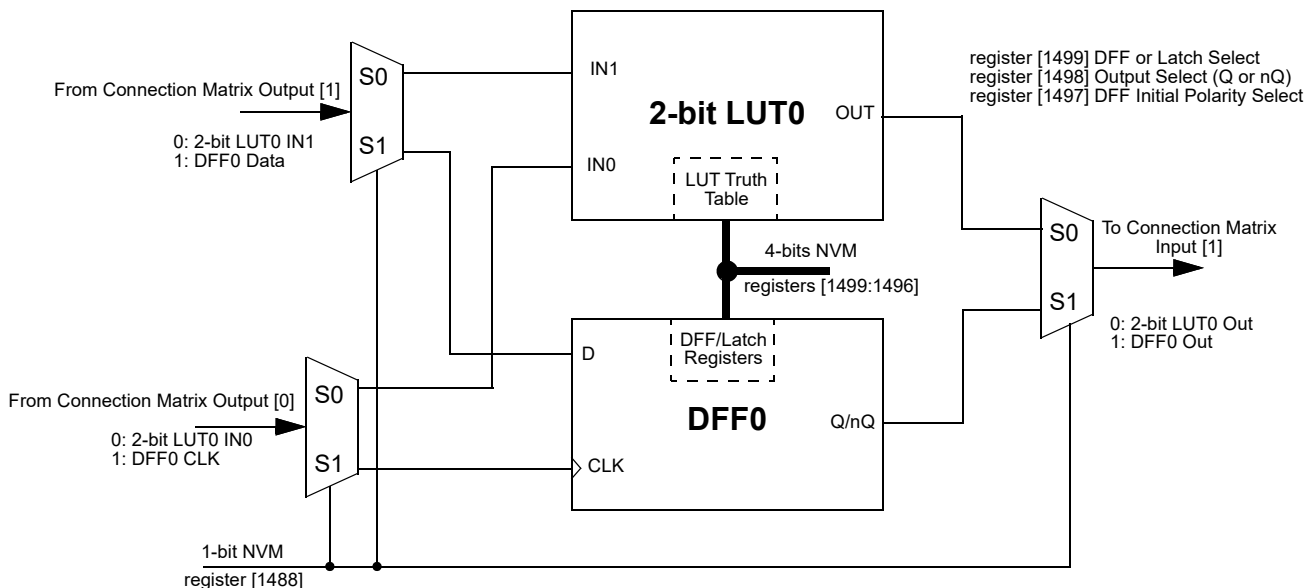

Figure 19: 2-bit LUT0 or DFF0

SLG46855-A

Auto AEC-Q100 Qualified GreenPAK Programmable Mixed-Signal Matrix

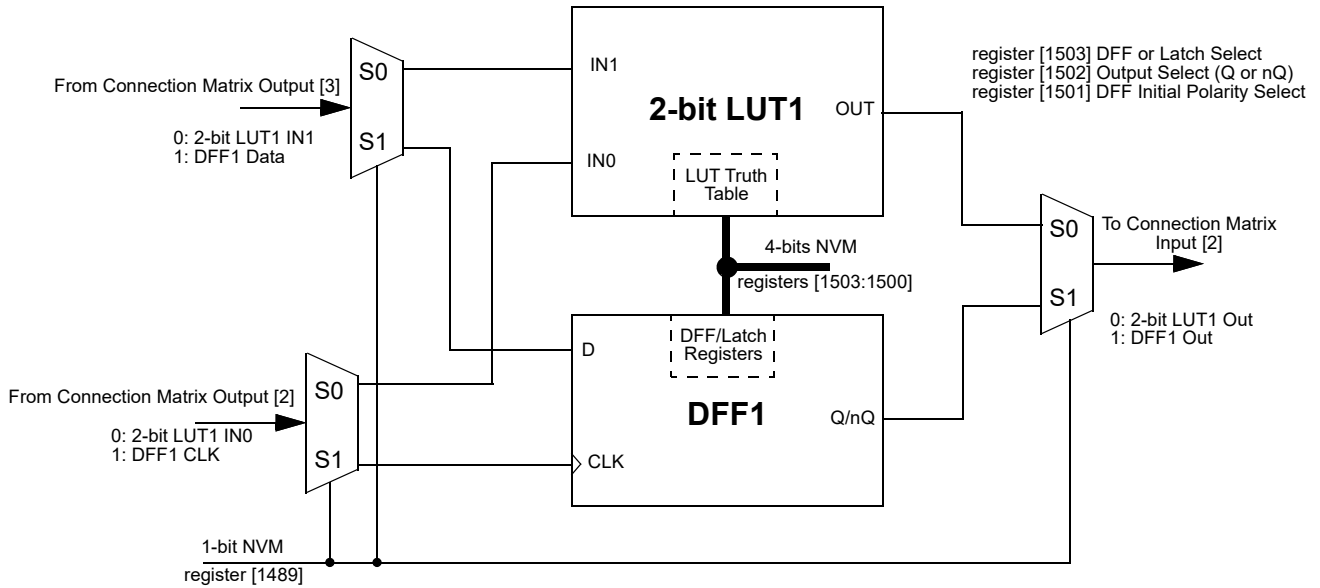

Figure 20: 2-bit LUT1 or DFF1

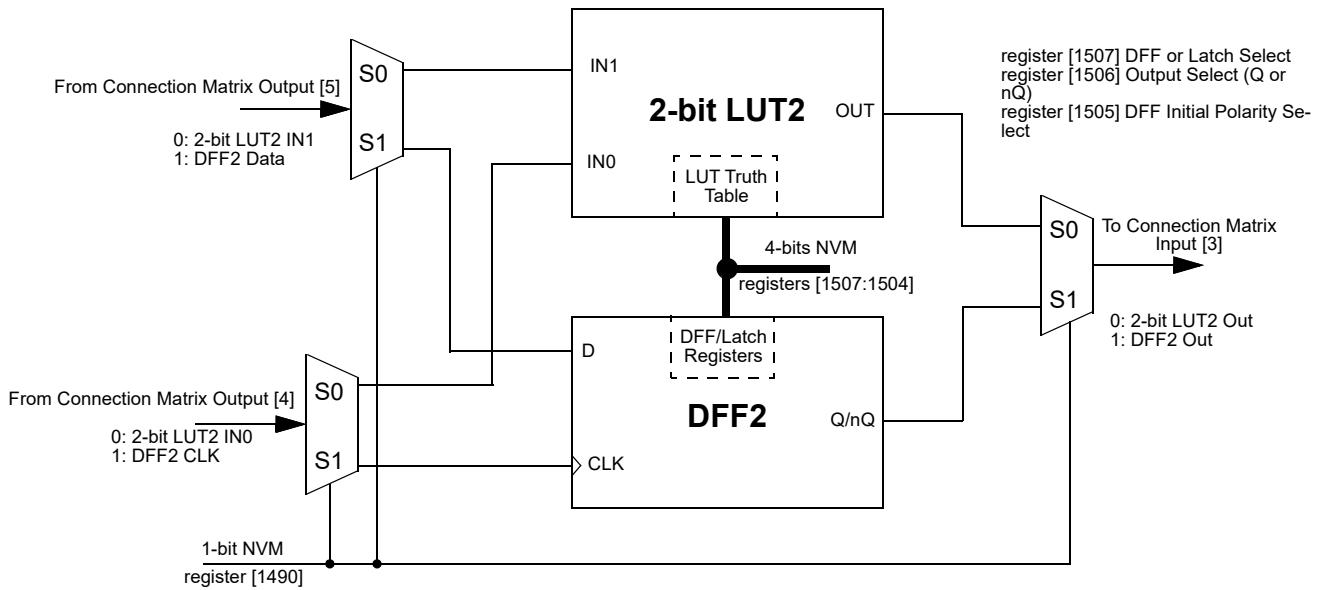

Figure 21: 2-bit LUT2 or DFF2

# SLG46855-A

## Auto AEC-Q100 Qualified GreenPAK Programmable Mixed-Signal Matrix

### 7.1.1 2-Bit LUT or D Flip-Flop Macrocell Used as 2-Bit LUT

**Table 26: 2-bit LUT0 Truth Table**

IN1	IN0	OUT	
0	0	register [1496]	LSB
0	1	register [1497]	
1	0	register [1498]	
1	1	register [1499]	MSB

**Table 27: 2-bit LUT1 Truth Table**

IN1	IN0	OUT	
0	0	register [1500]	LSB
0	1	register [1501]	
1	0	register [1502]	
1	1	register [1503]	MSB

**Table 28: 2-bit LUT2 Truth Table**

IN1	IN0	OUT	
0	0	register [1504]	LSB
0	1	register [1505]	
1	0	register [1506]	
1	1	register [1507]	MSB

This macrocell, when programmed for a LUT function, uses a 4-bit register to define their output function:

*2-Bit LUT0 is defined by registers [1499:1496]*

*2-Bit LUT1 is defined by registers [1503:1500]*

*2-Bit LUT2 is defined by registers [1507:1504]*

Table 28 shows the register bits for the standard digital logic devices (AND, NAND, OR, NOR, XOR, XNOR) that can be created within each of the 2-bit LUT logic cells

**Table 29: 2-bit LUT Standard Digital Functions**

Function	MSB			LSB
AND-2	1	0	0	0
NAND-2	0	1	1	1
OR-2	1	1	1	0
NOR-2	0	0	0	1
XOR-2	0	1	1	0
XNOR-2	1	0	0	1

### 7.1.2 Initial Polarity Operations

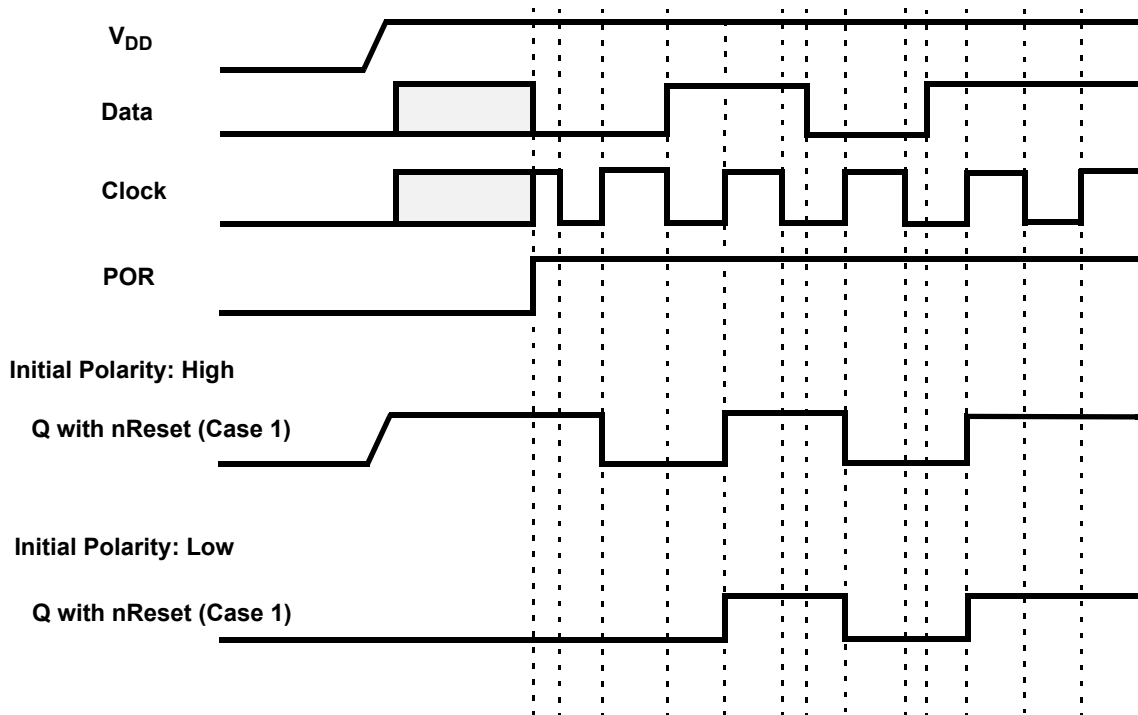

Figure 22: DFF Polarity Operations

### 7.2 2-BIT LUT OR PROGRAMMABLE PATTERN GENERATOR

The SLG46855-A has one combination function macrocell that can serve as a logic or timing function. This macrocell can serve as a Look Up Table (LUT), or Programmable Pattern Generator (PGen).

When used to implement LUT functions, the 2-bit LUT takes in two input signals from the connection matrix and produces a single output, which goes back into the connection matrix. When used as a LUT to implement combinatorial logic functions, the outputs of the LUT can be configured to any user defined function, including the following standard digital logic devices (AND, NAND, OR, NOR, XOR, XNOR). The user can also define the combinatorial relationship between inputs and outputs to be any selectable function.

It is possible to define the RST level for the PGen macrocell. There are both high level reset (RST) and a low level reset (nRST) options available, which are selected by register [1409]. When operating as a Programmable Pattern Generator, the output of the macrocell will clock out a sequence of two to sixteen bits that are user selectable in their bit values, and user selectable in the number of bits (up to sixteen) that are output before the pattern repeats.

SLG46855-A

Auto AEC-Q100 Qualified GreenPAK Programmable Mixed-Signal Matrix

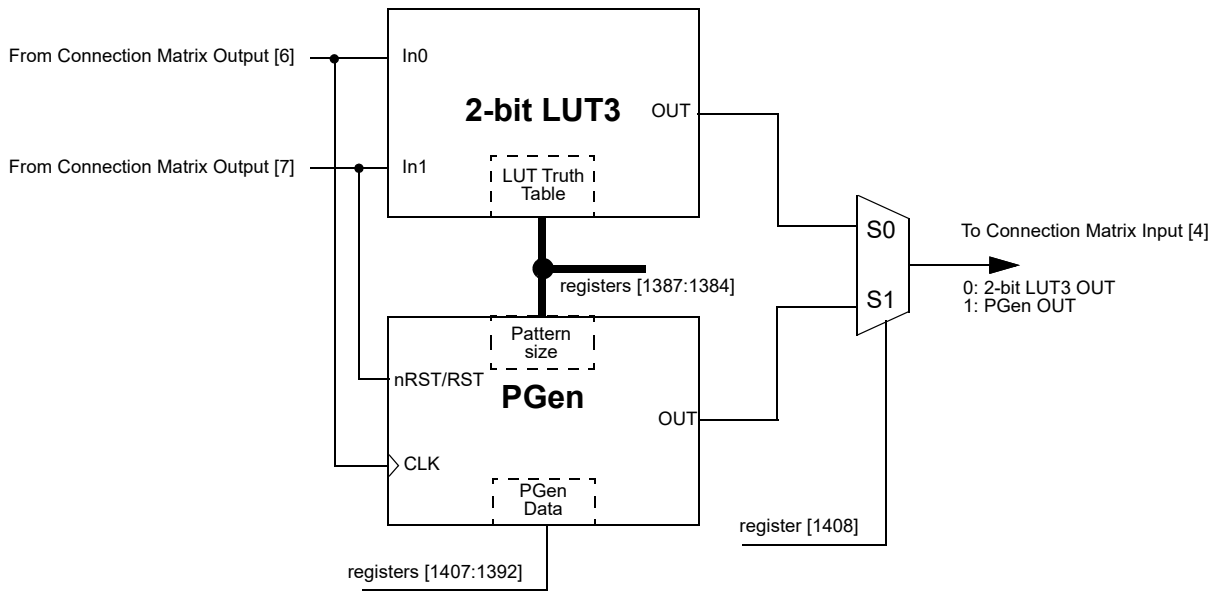

Figure 23: 2-bit LUT3 or PGen

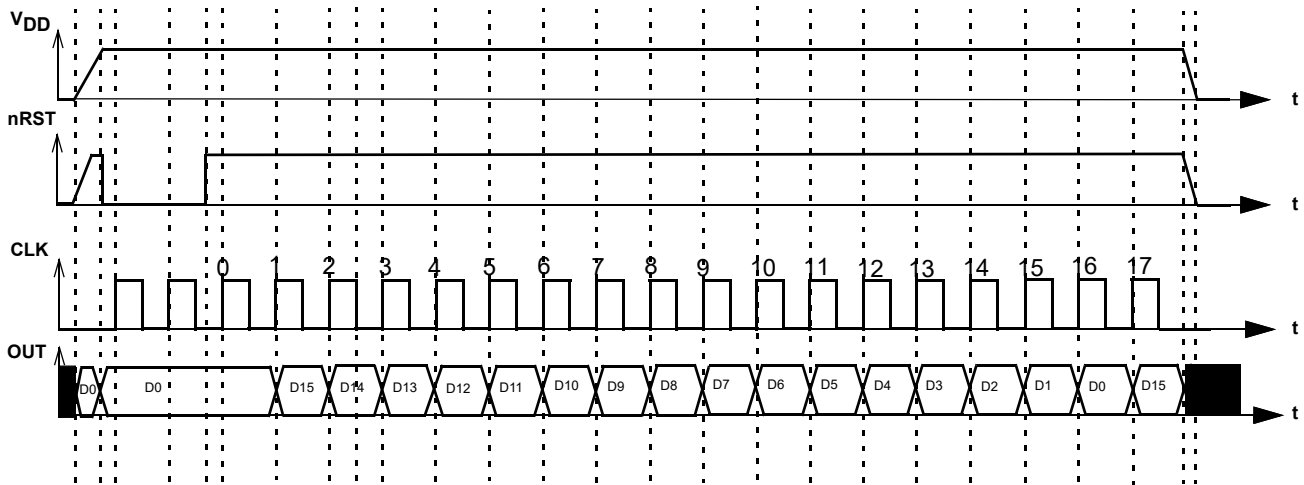

Figure 24: PGen Timing Diagram

## SLG46855-A

### Auto AEC-Q100 Qualified GreenPAK Programmable Mixed-Signal Matrix

#### 7.2.1 2-Bit LUT or PGen Macrocell Used as 2-Bit LUT

**Table 30: 2-bit LUT1 Truth Table**

IN1	IN0	OUT	
0	0	register [1384]	LSB
0	1	register [1385]	
1	0	register [1386]	
1	1	register [1387]	MSB

This macrocell, when programmed for a LUT function, uses a 4-bit register to define their output function:

*2-Bit LUT3 is defined by registers [1387:1384]*

Table 30 shows the register bits for the standard digital logic devices (AND, NAND, OR, NOR, XOR, XNOR) that can be created within each of the 2-bit LUT logic cells.

**Table 31: 2-bit LUT Standard Digital Functions**

Function	MSB			LSB
AND-2	1	0	0	0
NAND-2	0	1	1	1
OR-2	1	1	1	0
NOR-2	0	0	0	1
XOR-2	0	1	1	0
XNOR-2	1	0	0	1

#### 7.3 3-BIT LUT OR D FLIP-FLOP WITH SET/RESET MACROCELLS

There are nine macrocells that can serve as either 3-bit LUTs or as D Flip-Flops with Set/Reset inputs. When used to implement LUT functions, the 3-bit LUTs each take in three input signals from the connection matrix and produce a single output, which goes back into the connection matrix. When used to implement D Flip-Flop function, the three input signals from the connection matrix go to the data (D) and clock (CLK), and Reset/Set (nRST/nSET) inputs for the Flip-Flop, with the output going back to the connection matrix. It is possible to define the active level for the reset/set input of DFF/LATCH macrocell. There are both active high level reset/set (RST/SET) and active low level reset/set (nRST/nSET) options available which are selected by register [1445].

DFF3 operation will flow the functional description below:

- If register [1443] = 0, and the CLK is rising edge triggered, then Q = D, otherwise Q will not change.
- If register [1443] = 1, then data from D is written into the DFF by the rising edge on CLK and output to Q by the falling edge on CLK.

SLG46855-A

Auto AEC-Q100 Qualified GreenPAK Programmable Mixed-Signal Matrix

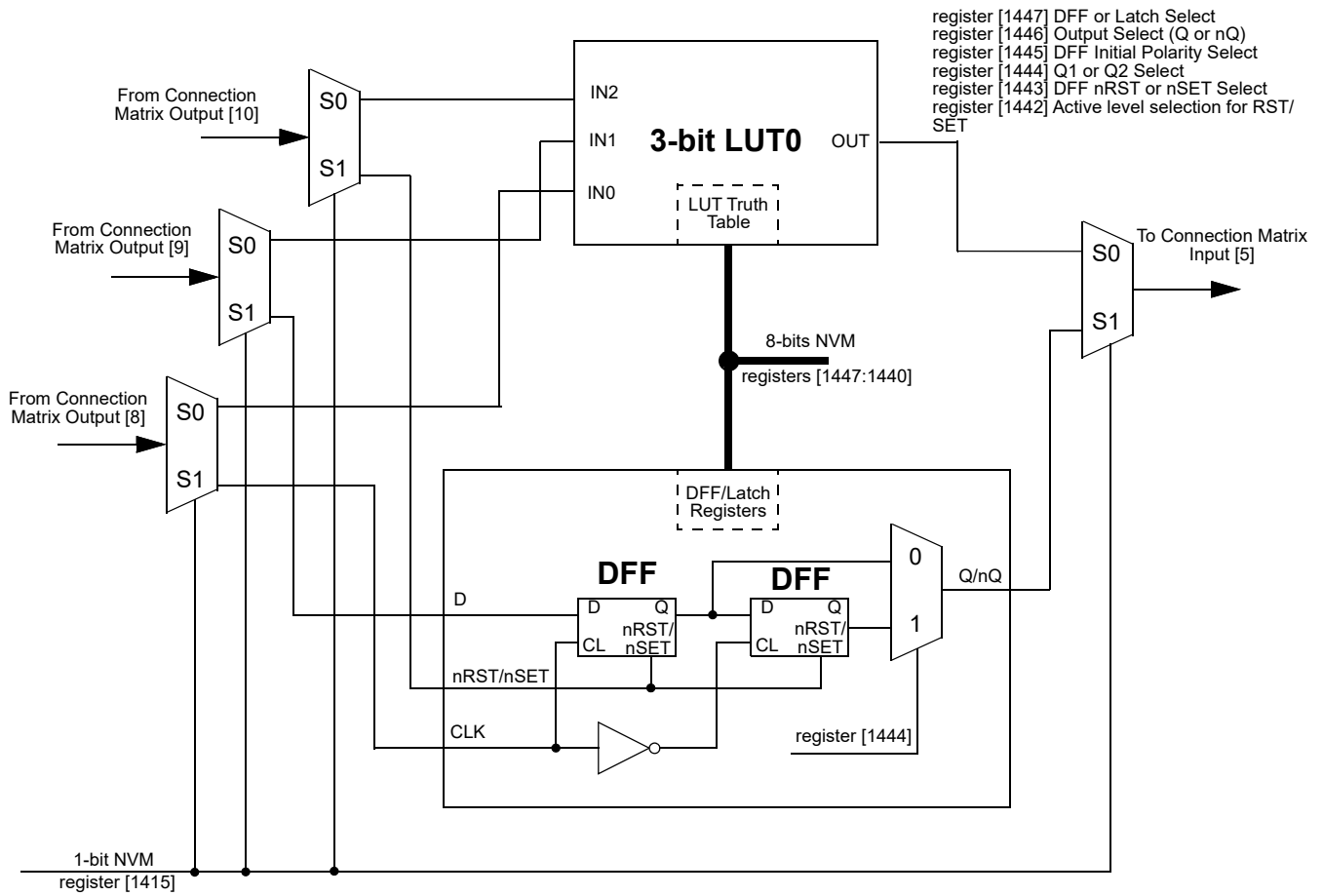

Figure 25: 3-bit LUT0 or DFF3



SLG46855-A

Auto AEC-Q100 Qualified GreenPAK Programmable Mixed-Signal Matrix

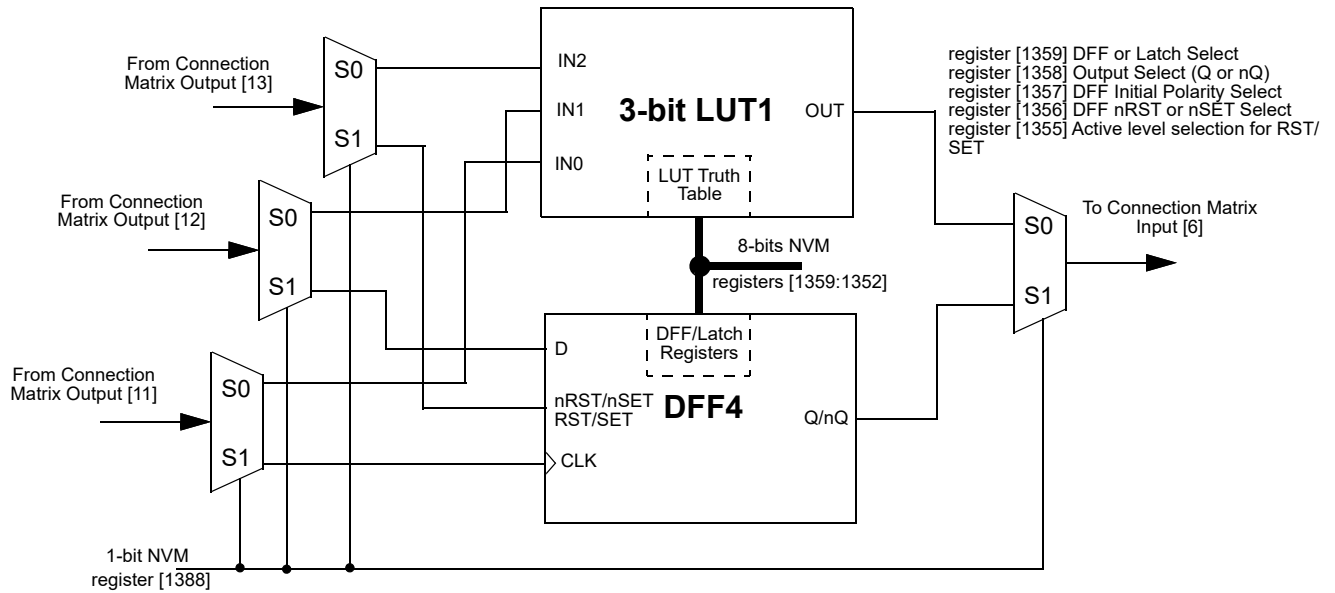

Figure 26: 3-bit LUT1 or DFF4

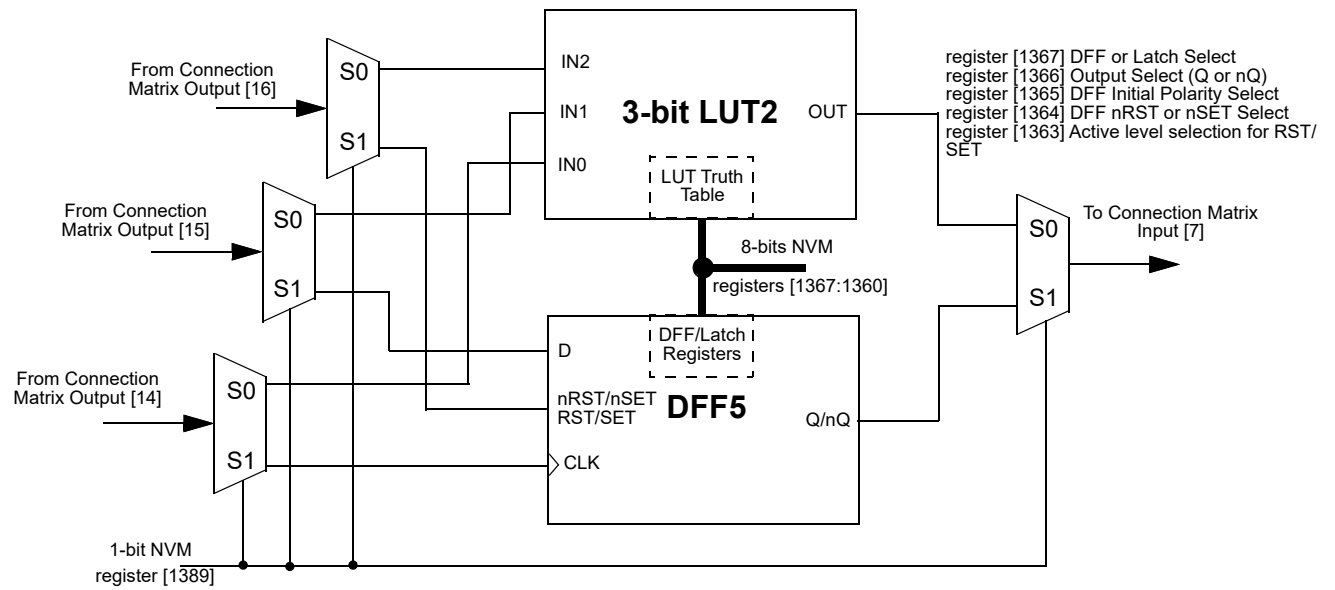

Figure 27: 3-bit LUT2 or DFF5

SLG46855-A

Auto AEC-Q100 Qualified GreenPAK Programmable Mixed-Signal Matrix

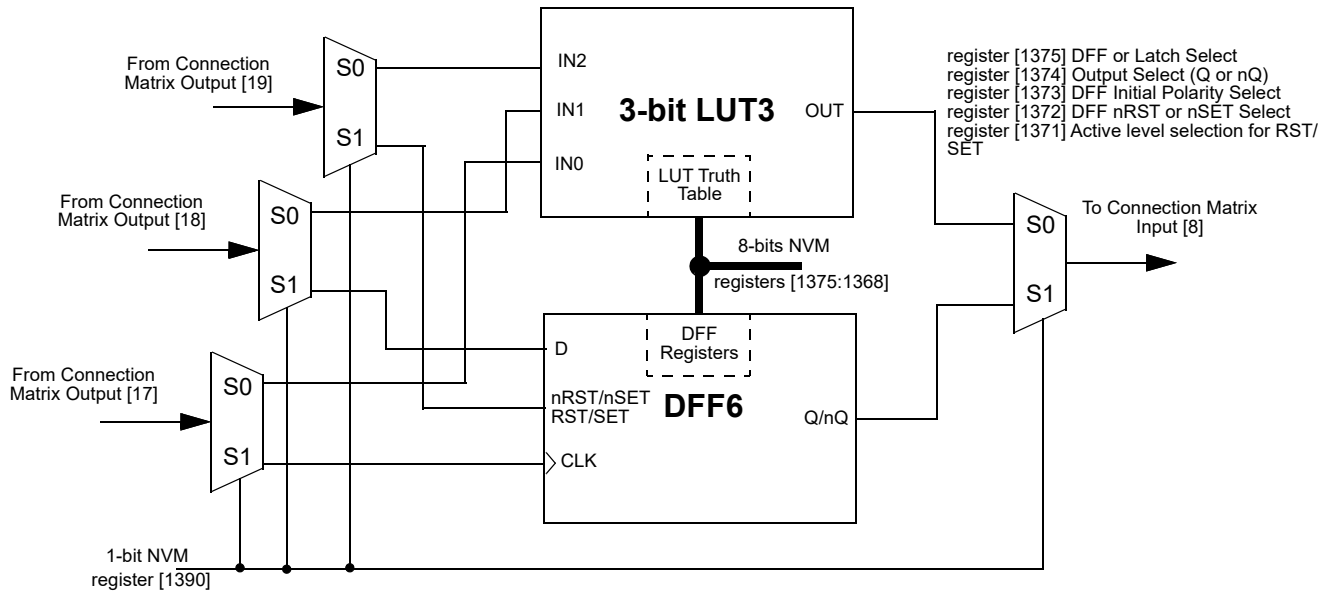

Figure 28: 3-bit LUT3 or DFF6

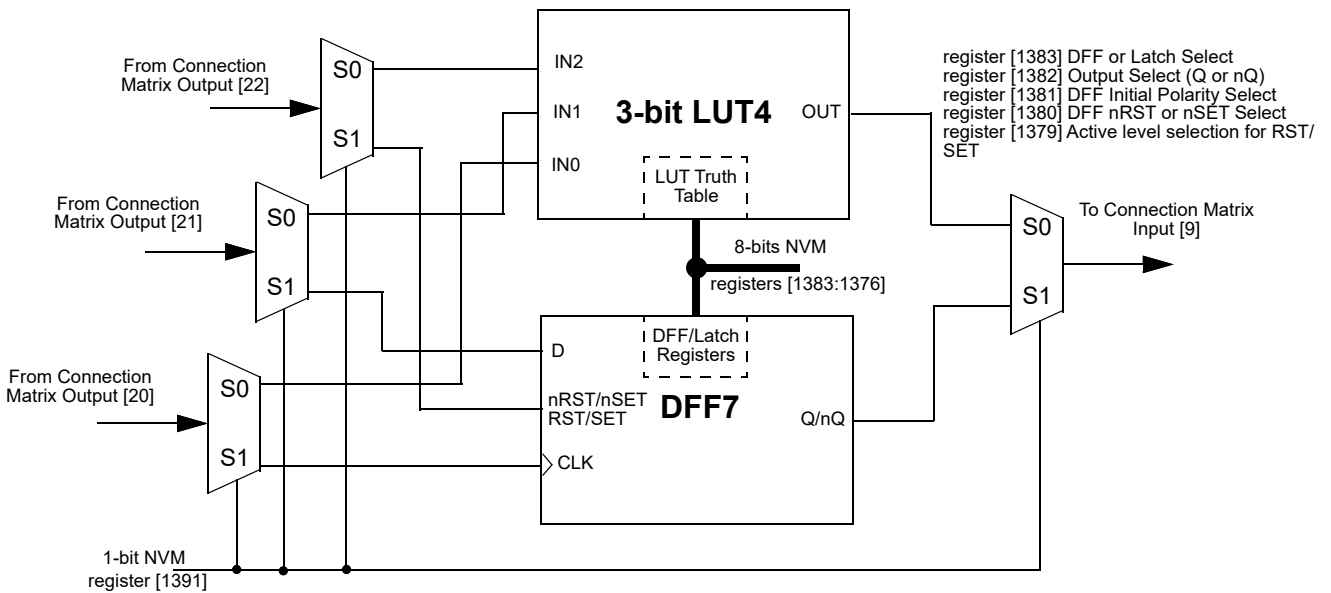

Figure 29: 3-bit LUT4 or DFF7

SLG46855-A

Auto AEC-Q100 Qualified GreenPAK Programmable Mixed-Signal Matrix

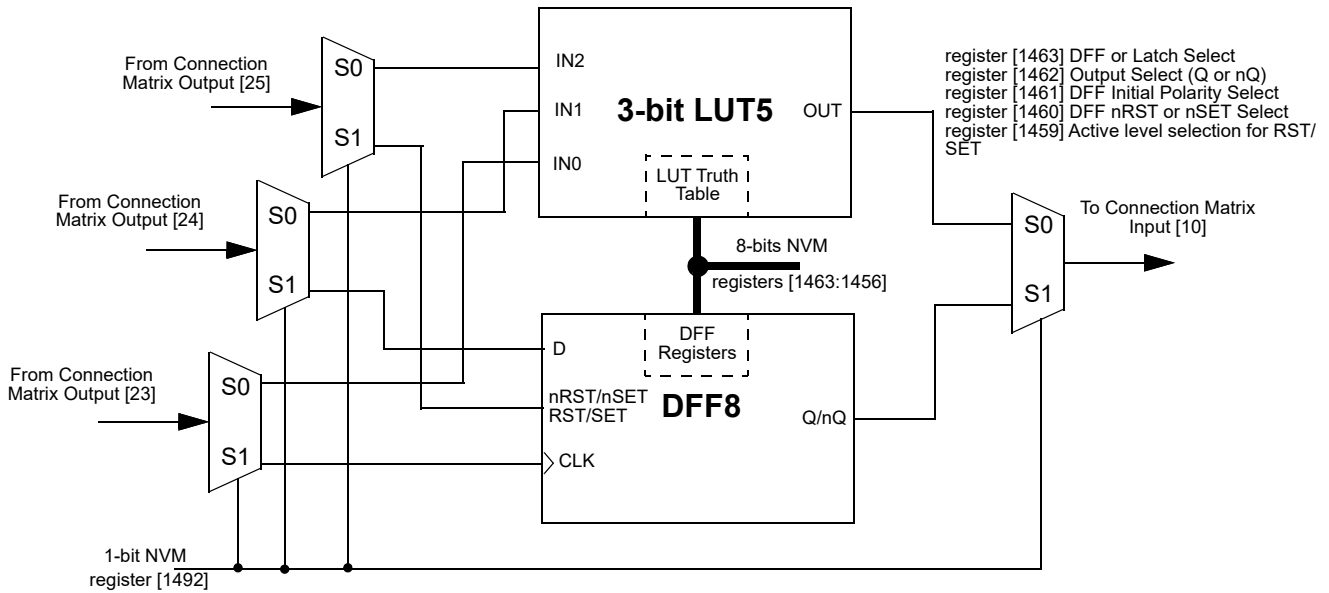

Figure 30: 3-bit LUT5 or DFF8

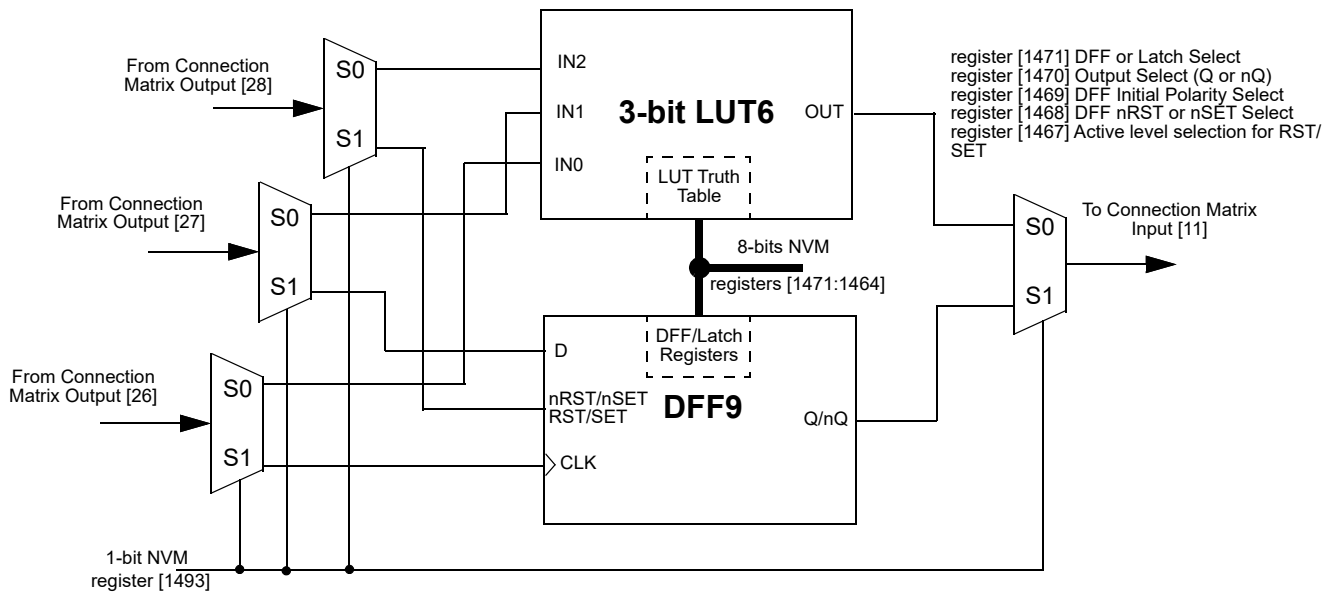

Figure 31: 3-bit LUT6 or DFF9

SLG46855-A

Auto AEC-Q100 Qualified GreenPAK Programmable Mixed-Signal Matrix

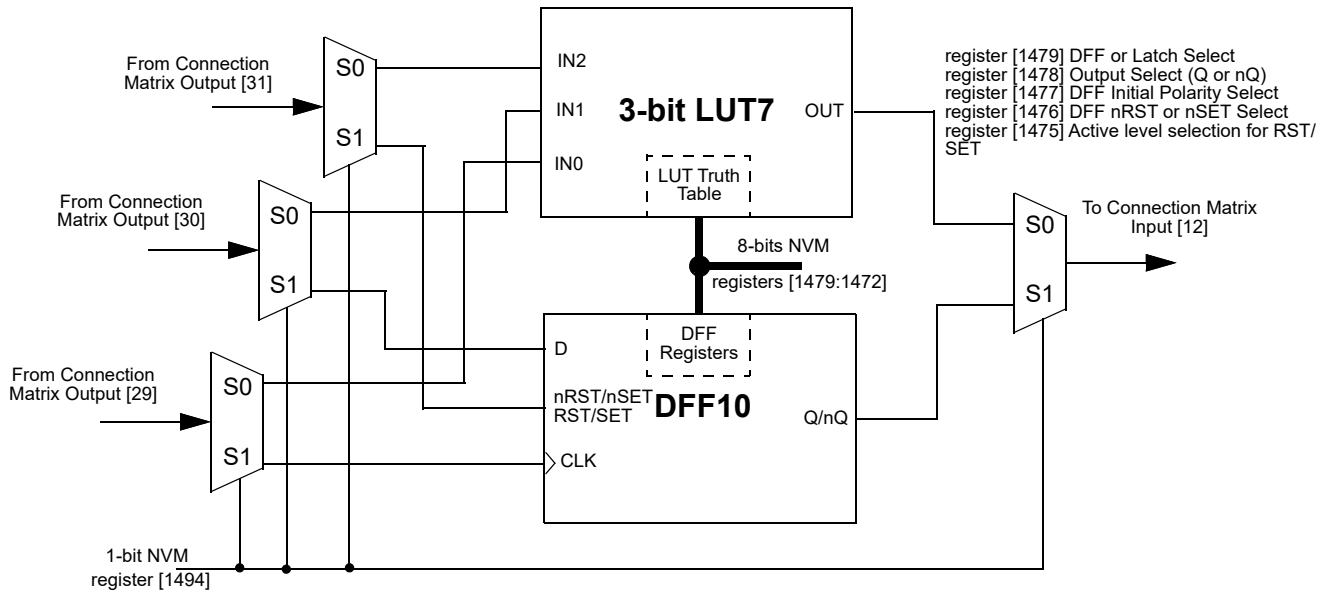

Figure 32: 3-bit LUT7 or DFF10

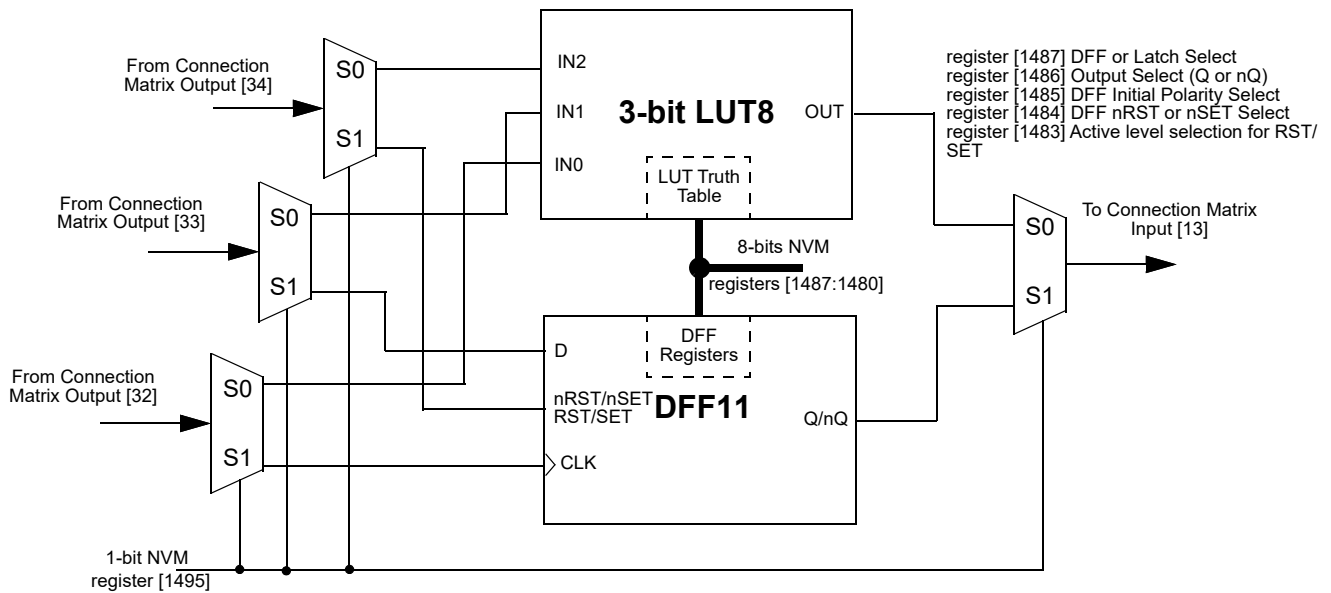

Figure 33: 3-bit LUT8 or DFF11

# SLG46855-A

## Auto AEC-Q100 Qualified GreenPAK Programmable Mixed-Signal Matrix

### 7.3.1 3-Bit LUT or D Flip-Flop Macrocells Used as 3-Bit LUTs

**Table 32: 3-bit LUT0 Truth Table**

IN2	IN1	IN0	OUT	
0	0	0	register [1440]	LSB
0	0	1	register [1441]	
0	1	0	register [1442]	
0	1	1	register [1443]	
1	0	0	register [1444]	
1	0	1	register [1445]	
1	1	0	register [1446]	
1	1	1	register [1447]	MSB

**Table 33: 3-bit LUT1 Truth Table**

IN2	IN1	IN0	OUT	
0	0	0	register [1352]	LSB
0	0	1	register [1353]	
0	1	0	register [1354]	
0	1	1	register [1355]	
1	0	0	register [1356]	
1	0	1	register [1357]	
1	1	0	register [1358]	
1	1	1	register [1359]	MSB

**Table 34: 3-bit LUT2 Truth Table**

IN2	IN1	IN0	OUT	
0	0	0	register [1360]	LSB
0	0	1	register [1361]	
0	1	0	register [1362]	
0	1	1	register [1363]	
1	0	0	register [1364]	
1	0	1	register [1365]	
1	1	0	register [1366]	
1	1	1	register [1367]	MSB

**Table 35: 3-bit LUT3 Truth Table**

IN2	IN1	IN0	OUT	
0	0	0	register [1368]	LSB
0	0	1	register [1369]	
0	1	0	register [1370]	
0	1	1	register [1371]	
1	0	0	register [1372]	
1	0	1	register [1373]	
1	1	0	register [1374]	
1	1	1	register [1375]	MSB

**Table 36: 3-bit LUT4 Truth Table**

IN2	IN1	IN0	OUT	
0	0	0	register [1376]	LSB
0	0	1	register [1377]	
0	1	0	register [1378]	
0	1	1	register [1379]	
1	0	0	register [1380]	
1	0	1	register [1381]	
1	1	0	register [1382]	
1	1	1	register [1383]	MSB

**Table 37: 3-bit LUT5 Truth Table**

IN2	IN1	IN0	OUT	
0	0	0	register [1356]	LSB
0	0	1	register [1357]	
0	1	0	register [1358]	
0	1	1	register [1359]	
1	0	0	register [1360]	
1	0	1	register [1361]	
1	1	0	register [1362]	
1	1	1	register [1363]	MSB

**Table 38: 3-bit LUT6 Truth Table**

IN2	IN1	IN0	OUT	
0	0	0	register [1364]	LSB
0	0	1	register [1365]	
0	1	0	register [1366]	
0	1	1	register [1367]	
1	0	0	register [1368]	
1	0	1	register [1369]	
1	1	0	register [1370]	
1	1	1	register [1371]	MSB

**Table 39: 3-bit LUT7 Truth Table**

IN2	IN1	IN0	OUT	
0	0	0	register [1472]	LSB
0	0	1	register [1473]	
0	1	0	register [1474]	
0	1	1	register [1475]	
1	0	0	register [1476]	
1	0	1	register [1477]	
1	1	0	register [1478]	
1	1	1	register [1479]	MSB

**Auto AEC-Q100 Qualified GreenPAK Programmable Mixed-Signal Matrix**
**Table 40: 3-bit LUT8 Truth Table**

IN2	IN1	IN0	OUT	
0	0	0	register [1480]	LSB
0	0	1	register [1481]	
0	1	0	register [1482]	
0	1	1	register [1483]	
1	0	0	register [1484]	
1	0	1	register [1485]	
1	1	0	register [1486]	
1	1	1	register [1487]	MSB

Each macrocell, when programmed for a LUT function, uses a 8-bit register to define their output function:

*3-Bit LUT0 is defined by registers [1447:1440]*

*3-Bit LUT1 is defined by registers [1359:1352]*

*3-Bit LUT2 is defined by registers [1367:1360]*

*3-Bit LUT3 is defined by registers [1375:1368]*

*3-Bit LUT4 is defined by registers [1383:1376]*

*3-Bit LUT5 is defined by registers [1463:1456]*

*3-Bit LUT6 is defined by registers [1471:1464]*

*3-Bit LUT7 is defined by registers [1479:1472]*

*3-Bit LUT8 is defined by registers [1487:1480]*

Table 40 shows the register bits for the standard digital logic devices (AND, NAND, OR, NOR, XOR, XNOR) that can be created within each of the four 3-bit LUT logic cells.

**Table 41: 3-bit LUT Standard Digital Functions**

Function	MSB							LSB
AND-3	1	0	0	0	0	0	0	0
NAND-3	0	1	1	1	1	1	1	1
OR-3	1	1	1	1	1	1	1	0
NOR-3	0	0	0	0	0	0	0	1
XOR-3	1	0	0	1	0	1	1	0
XNOR-3	0	1	1	0	1	0	0	1

SLG46855-A

Auto AEC-Q100 Qualified GreenPAK Programmable Mixed-Signal Matrix

7.3.2 Initial Polarity Operations

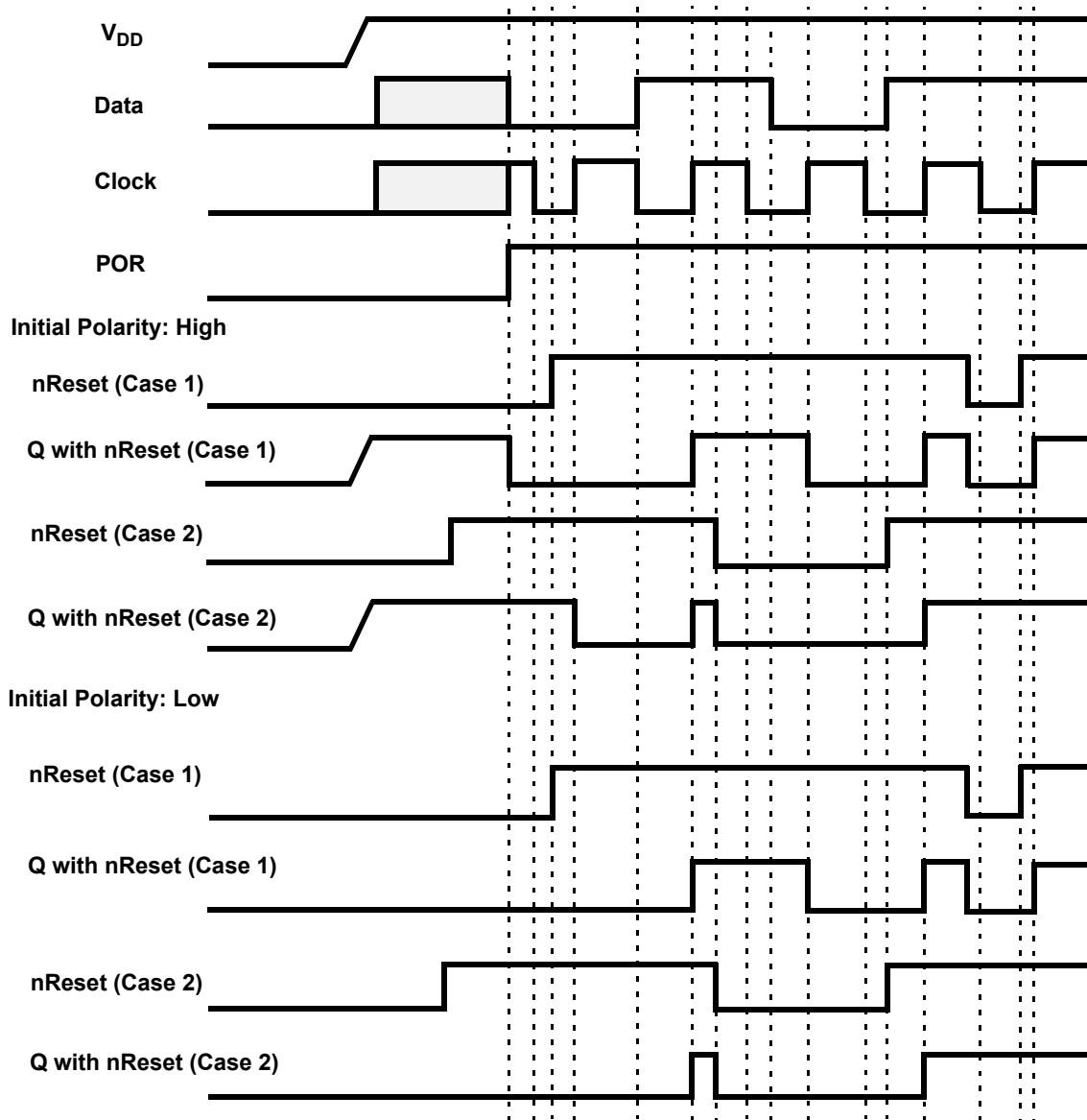
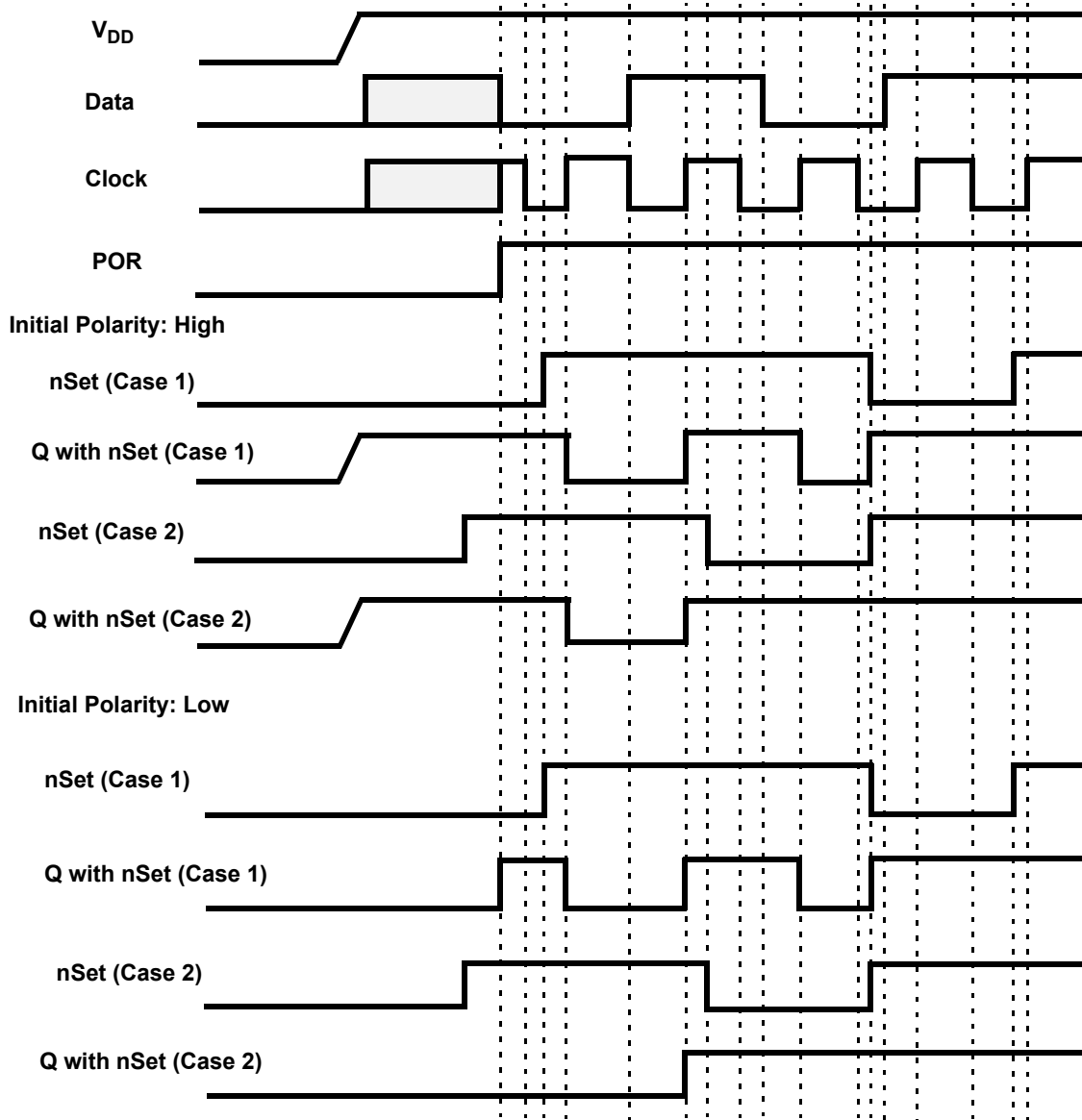

Figure 34: DFF Polarity Operations with nReset



**Figure 35: DFF Polarity Operations with nSet**

#### 7.4 4-BIT LUT OR D FLIP-FLOP WITH SET/RESET MACROCELL

There is one macrocell that can serve as either a 4-bit LUT or as a D Flip-Flop with Set/Reset inputs. When used to implement LUT functions, the 4-bit LUT takes in four input signals from the connection matrix and produce a single output, which goes back into the connection matrix. When used to implement D Flip-Flop function, the input signals from the connection matrix go to the data (D) and clock (CLK), and Reset/Set (nRST/nSET) inputs for the Flip-Flop, with the output going back to the connection matrix.

- If register [1436] = 0, and the CLK is rising edge triggered, then Q = D, otherwise Q will not change.
- If register [1436] = 1, then data from D is written into the DFF by the rising edge on CLK and output to Q by the falling edge on CLK.

It is possible to define the active level for the reset/set input of DFF/LATCH macrocell. There are both active high level reset/set (RST/SET) and active low level reset/set (nRST/nSET) options available which are selected by register [1434].



SLG46855-A

Auto AEC-Q100 Qualified GreenPAK Programmable Mixed-Signal Matrix

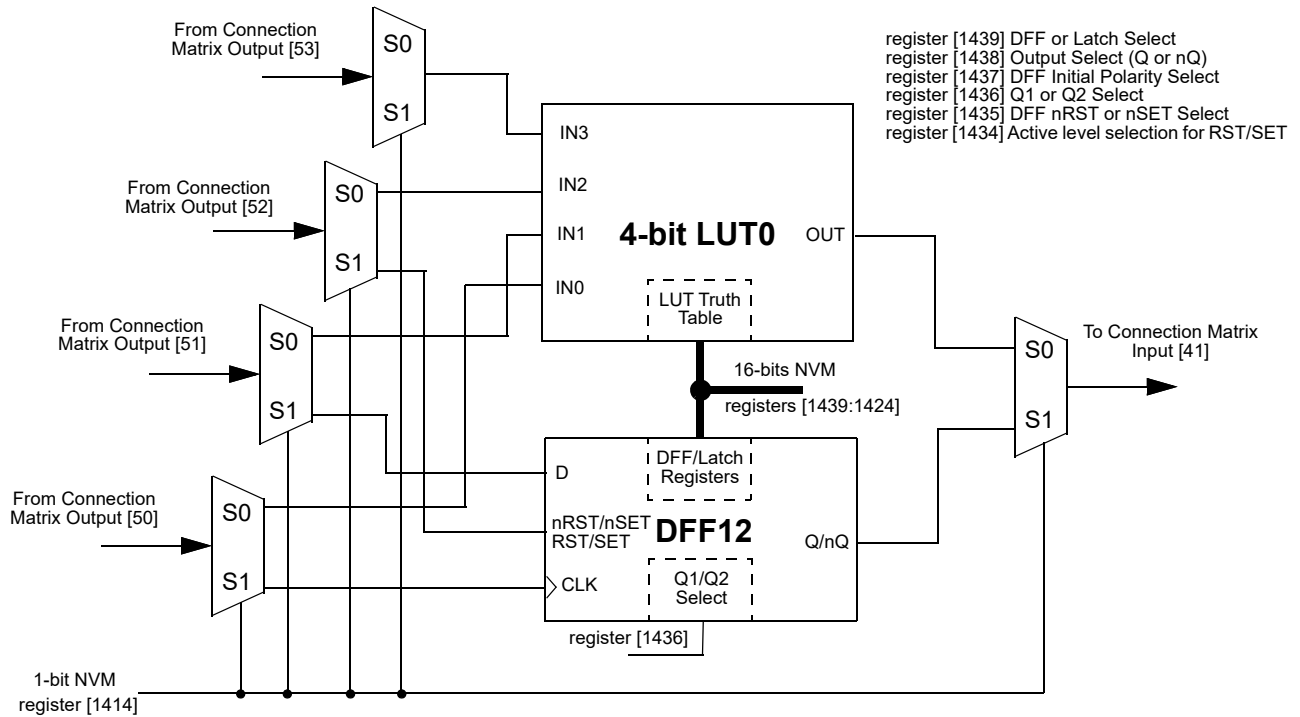

Figure 36: 4-bit LUT0 or DFF12

7.4.1 4-Bit LUT Macrocell Used as 4-Bit LUT

Table 42: 4-bit LUT0 Truth Table

IN3	IN2	IN1	IN0	OUT	
0	0	0	0	register [1424]	LSB
0	0	0	1	register [1425]	
0	0	1	0	register [1426]	
0	0	1	1	register [1427]	
0	1	0	0	register [1428]	
0	1	0	1	register [1429]	
0	1	1	0	register [1430]	
0	1	1	1	register [1431]	
1	0	0	0	register [1432]	
1	0	0	1	register [1433]	
1	0	1	0	register [1434]	
1	0	1	1	register [1435]	
1	1	0	0	register [1436]	
1	1	0	1	register [1437]	
1	1	1	0	register [1438]	
1	1	1	1	register [1439]	MSB

**Auto AEC-Q100 Qualified GreenPAK Programmable Mixed-Signal Matrix**

This macrocell, when programmed for a LUT function, uses a 16-bit register to define their output function:

*4-Bit LUT0 is defined by registers [1439:1424]*

**Table 43: 4-bit LUT Standard Digital Functions**

Function	MSB															LSB
AND-4	1	0	0	0	0	0	0	0	0	0	0	0	0	0	0	0
NAND-4	0	1	1	1	1	1	1	1	1	1	1	1	1	1	1	1
OR-4	1	1	1	1	1	1	1	1	1	1	1	1	1	1	1	0
NOR-4	0	0	0	0	0	0	0	0	0	0	0	0	0	0	0	1
XOR-4	0	1	1	0	1	0	0	1	1	0	0	1	0	1	1	0
XNOR-4	1	0	0	1	0	1	1	0	0	1	1	0	1	0	0	1

### 7.5 3-BIT LUT OR PIPE DELAY/RIPPLE COUNTER MACROCELL

There is one macrocell that can serve as either a 3-bit LUT or as a Pipe Delay/Ripple Counter.

When used to implement LUT functions, the 3-bit LUT takes in three input signals from the connection matrix and produces a single output, which goes back into the connection matrix.

When used as a Pipe Delay, there are three inputs signals from the matrix, Input (IN), Clock (CLK), and Reset (nRST). The Pipe Delay cell is built from 16 D Flip-Flop logic cells that provide the three delay options, two of which are user selectable. The DFF cells are tied in series where the output (Q) of each delay cell goes to the next DFF cell input (IN). Both of the two outputs (OUT0 and OUT1) provide user selectable options for 1 – 16 stages of delay. There are delay output points for each set of the OUT0 and OUT1 outputs to a 4-input mux that is controlled by registers [1419:1416] for OUT0 and registers [1423:1420] for OUT1. The 4-input mux is used to control the selection of the amount of delay.

The overall time of the delay is based on the clock used in the SLG46855-A design. Each DFF cell has a time delay of the inverse of the clock time (either external clock or the internal Oscillator within the SLG46855-A). The sum of the number of DFF cells used will be the total time delay of the Pipe Delay logic cell. OUT1 Output can be inverted (as selected by register [1413]).

In the Ripple Counter mode there are 3 options for setting which use 7 bits. There are 3 bits to set **nSET value (SV)** in range from 0 to 7. This value will be set into the Ripple Counter outputs when nSET input goes LOW. **End value (EV)** will use 3 bits for setting output code, which will be last code in the cycle. After reaching the EV, the Ripple Counter goes to the first code by the rising edge on CLK input. The **Functionality mode** option uses 1 bit. This setting defines how exactly Ripple Counter will operate.

The user can select one of the functionality modes by register: RANGE or FULL. If the RANGE option is selected, the count starts from SV. If UP input is LOW the count goes down: SV→EV→EV-1 to SV+1→SV, and others (if SV is smaller than EV), or SV→SV-1 to EV+1→EV→SV (if SV is bigger than EV). If UP input is HIGH, count starts from SV up to EV, and others.

In the FULL range configuration the Ripple Counter functions as follows. If UP input is LOW, the count starts from SV and goes down to 0. Then current counter value jumps to EV and goes down to 0, and others.

If UP input is HIGH, count goes up starting from SV. Then current counter value jumps to 0 and counts up to EV, and others. See Ripple Counter functionality example in [Figure 38](#).

Every step is executed by the rising edge on CLK input.

SLG46855-A

Auto AEC-Q100 Qualified GreenPAK Programmable Mixed-Signal Matrix

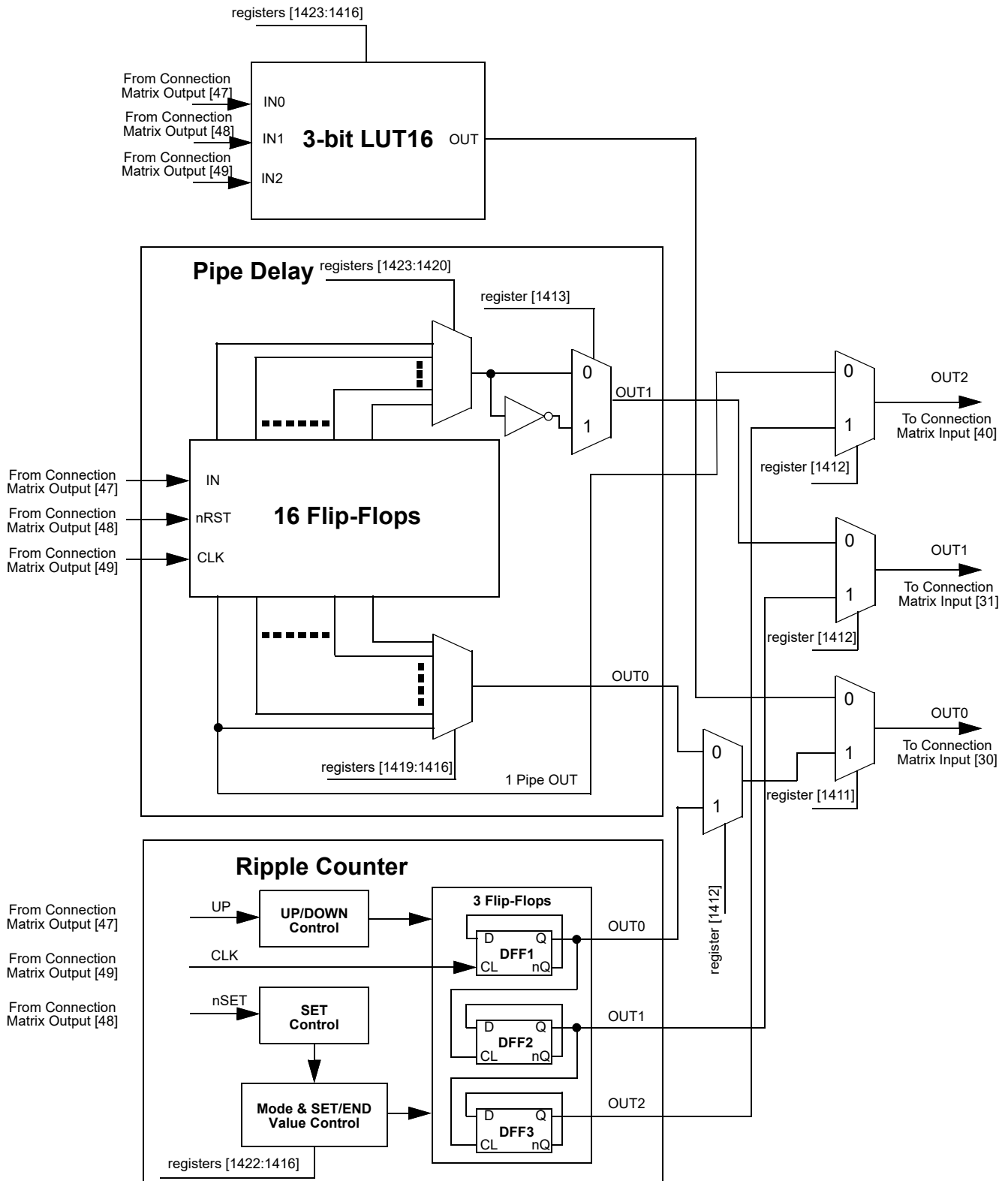

Figure 37: 3-bit LUT16/Pipe Delay/Ripple Counter

SLG46855-A

Auto AEC-Q100 Qualified GreenPAK Programmable Mixed-Signal Matrix

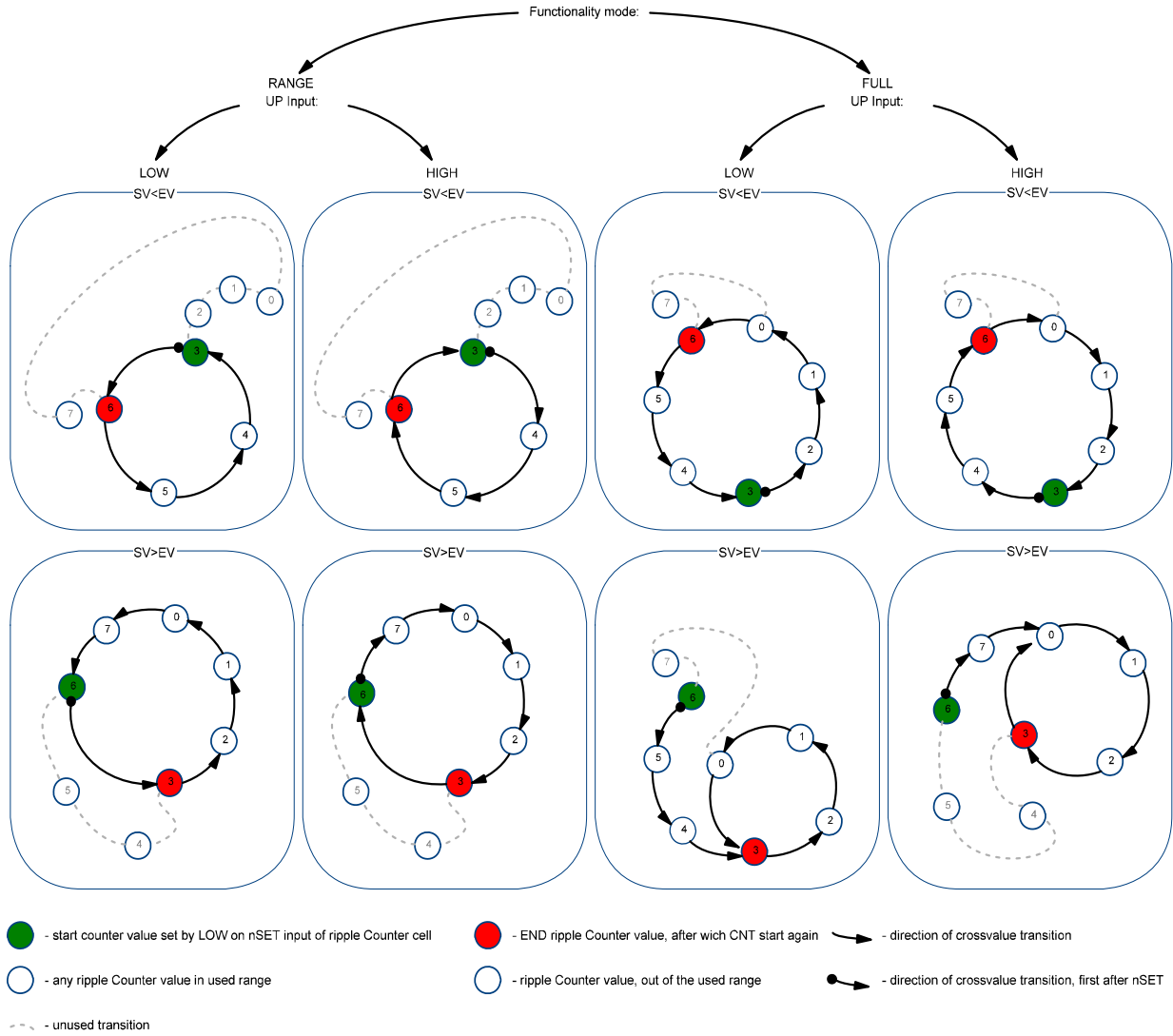

Figure 38: Example: Ripple Counter Functionality

## SLG46855-A

### Auto AEC-Q100 Qualified GreenPAK Programmable Mixed-Signal Matrix

#### 7.5.1 3-Bit LUT or Pipe Delay Macrocells Used as 3-Bit LUT

**Table 44: 3-bit LUT16 Truth Table**

IN2	IN1	IN0	OUT
0	0	0	register [1416]
0	0	1	register [1417]
0	1	0	register [1418]
0	1	1	register [1419]
1	0	0	register [1420]
1	0	1	register [1421]
1	1	0	register [1422]
1	1	1	register [1423]

Each macrocell, when programmed for a LUT function, uses a 8-bit register to define their output function:

*3-Bit LUT16 is defined by registers [1423:1416]*

### 8 Multi-Function Macrocells

The SLG46855-A has 8 Multi-Function macrocells that can serve more than one logic or timing function. In each case, they can serve as a LUT, DFF with flexible settings, or as CNT/DLY with multiple modes, such as One Shot, Frequency Detect, Edge Detect, and others. Also, the macrocell is capable to combine those functions: LUT/DFF connected to CNT/DLY or CNT/DLY connected to LUT/DFF, see [Figure 39](#).

See the list below for the functions that can be implemented in these macrocells:

- Seven macrocells that can serve as 3-bit LUTs/D Flip-Flops and as 8-Bit Counter/Delays
- One macrocell that can serve as a 4-bit LUT/D Flip-Flop and as 16-Bit Counter/Delay/FSM

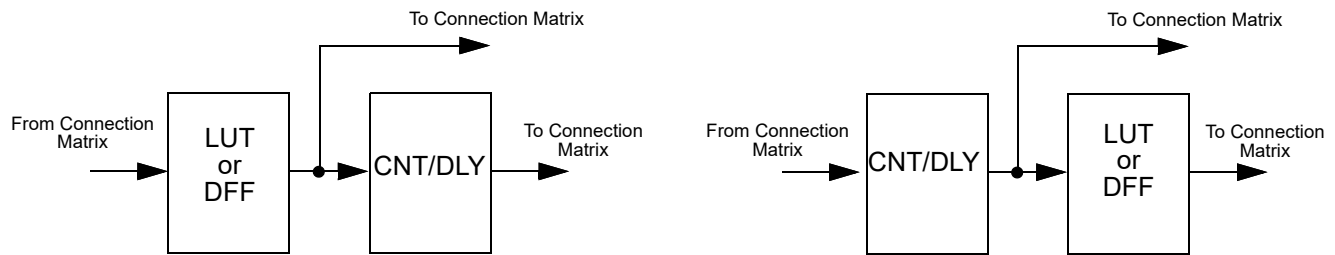

**Figure 39: Possible Connections Inside Multi-Function Macrocell**

Inputs/Outputs for the 8 Multi-Function function macrocells are configured from the connection matrix with specific logic functions being defined by the state of NVM bits.

When used as a LUT to implement combinatorial logic functions, the outputs of the LUTs can be configured to any user defined function, including the following standard digital logic devices (AND, NAND, OR, NOR, XOR, XNOR).

#### 8.1 3-BIT LUT OR DFF/LATCH WITH 8-BIT COUNTER/DELAY MACROCELLS

There are seven macrocells that can serve as 3-bit LUTs/D Flip-Flops and as 8-Bit Counter/Delays.

When used to implement LUT functions, the 3-bit LUTs each take in three input signals from the connection matrix and produce a single output, which goes back into the connection matrix or can be connected to CNT/DLY's input.

When used to implement D Flip-Flop function, the three input signals from the connection matrix go to the data (D), clock (CLK), and Reset/Set (nRST/nSET) inputs of the Flip-Flop, with the output going back to the connection matrix or to the CNT/DLY's input.

When used to implement Counter/Delays, each macrocell has a dedicated matrix input connection. For flexibility, each of these macrocells has a large selection of internal and external clock sources, as well as the option to chain from the output of the previous (N-1) CNT/DLY macrocell, to implement longer count/delay circuits. These macrocells can also operate in a One-Shot mode, which will generate an output pulse of user-defined width. They can also operate in a Frequency Detection or Edge Detection mode.

Counter/Delay macrocell has an initial value, which define its initial value after GPAK is powered up. It is possible to select initial Low or initial High, as well as initial value defined by a Delay In signal.

For example, in case initial LOW option is used, the rising edge delay will start operation.

For timing diagrams refer to sections [7.1](#) and [8.3](#).

**Note:** After two DFF – counters initialize with counter data = 0 after POR.  
 Initial state = 1 – counters initialize with counter data = 0 after POR. Initial state = 0 And After two DFF is bypass – counters initialize with counter data after POR.

SLG46855-A

Auto AEC-Q100 Qualified GreenPAK Programmable Mixed-Signal Matrix

CNT6 and CNT7 current count value can be read via I<sup>2</sup>C. However, it is possible to change the counter data (value counter starts operating from) for any macrocell using I<sup>2</sup>C write commands. In this mode, it is possible to load count data immediately (after two DFF) or after counter ends counting. See Section 15.6.1 for further details.

8.1.1 3-Bit LUT or 8-Bit CNT/DLY Block Diagrams

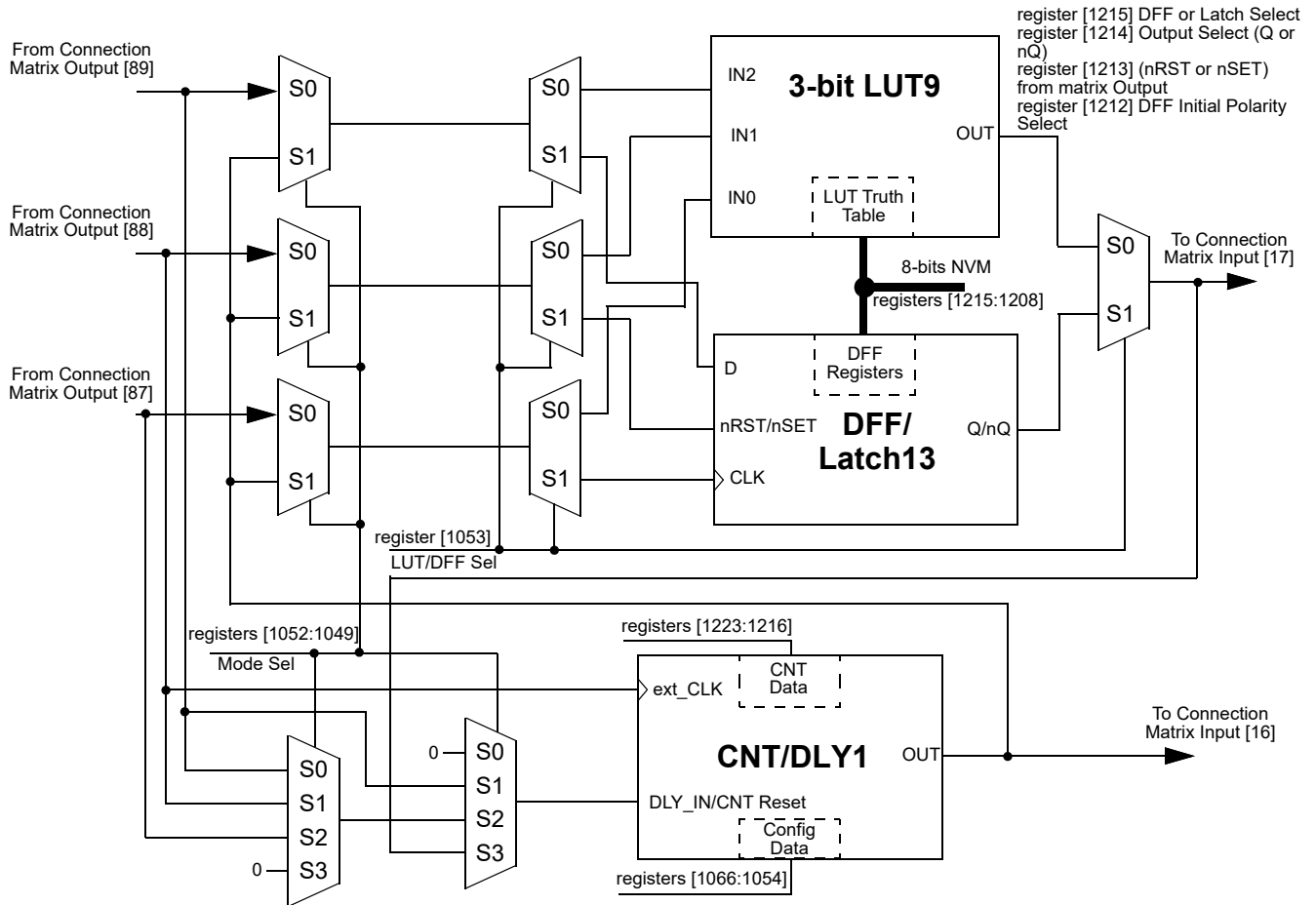

Figure 40: 8-bit Multi-Function Macrocells Block Diagram (3-bit LUT9/DFF13, CNT/DLY1)

SLG46855-A

Auto AEC-Q100 Qualified GreenPAK Programmable Mixed-Signal Matrix

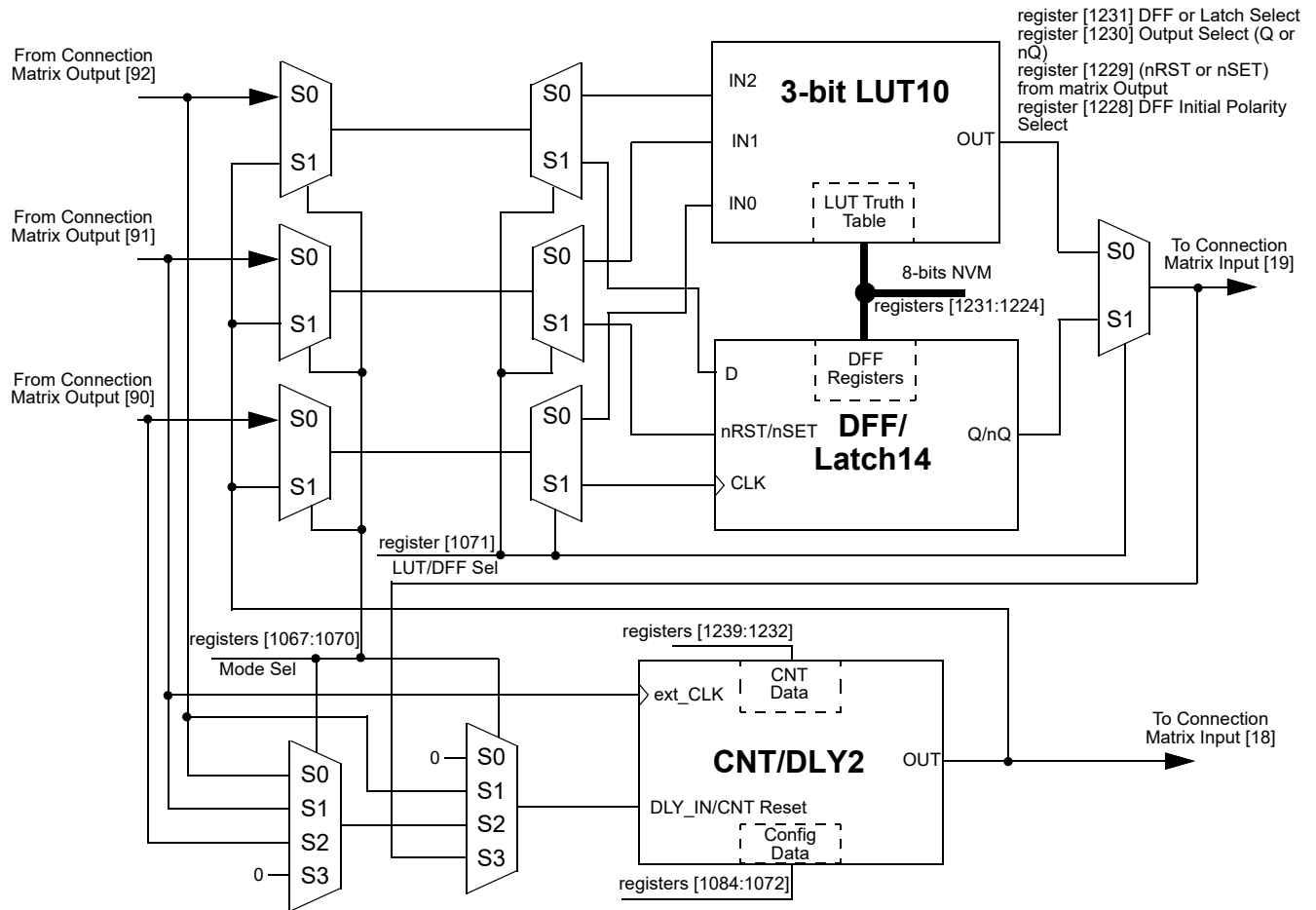

Figure 41: 8-bit Multi-Function Macrocells Block Diagram (3-bit LUT10/DFF14, CNT/DLY2)



SLG46855-A

Auto AEC-Q100 Qualified GreenPAK Programmable Mixed-Signal Matrix

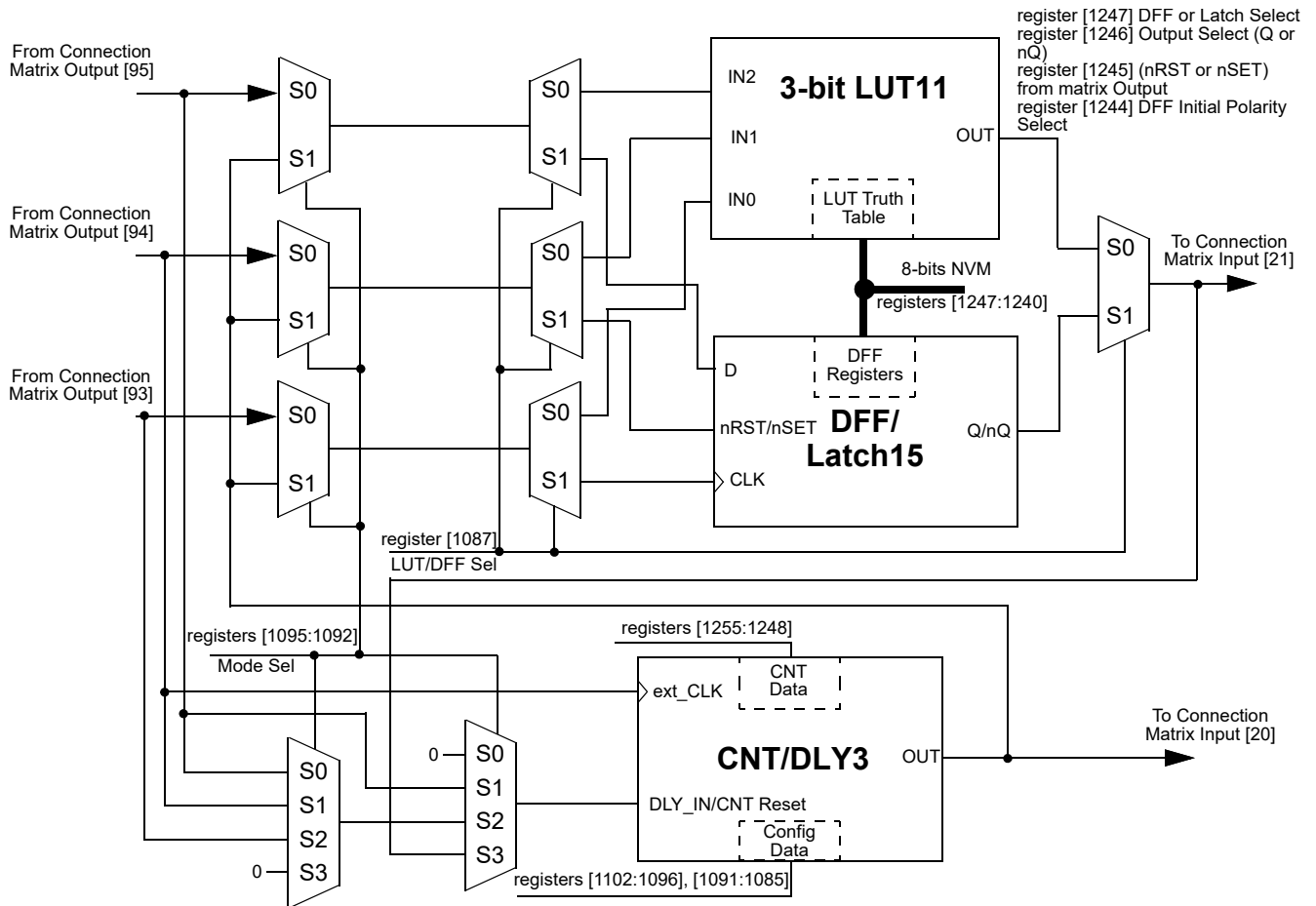

Figure 42: 8-bit Multi-Function Macrocells Block Diagram (3-bit LUT11/DFF15, CNT/DLY3)

SLG46855-A

Auto AEC-Q100 Qualified GreenPAK Programmable Mixed-Signal Matrix

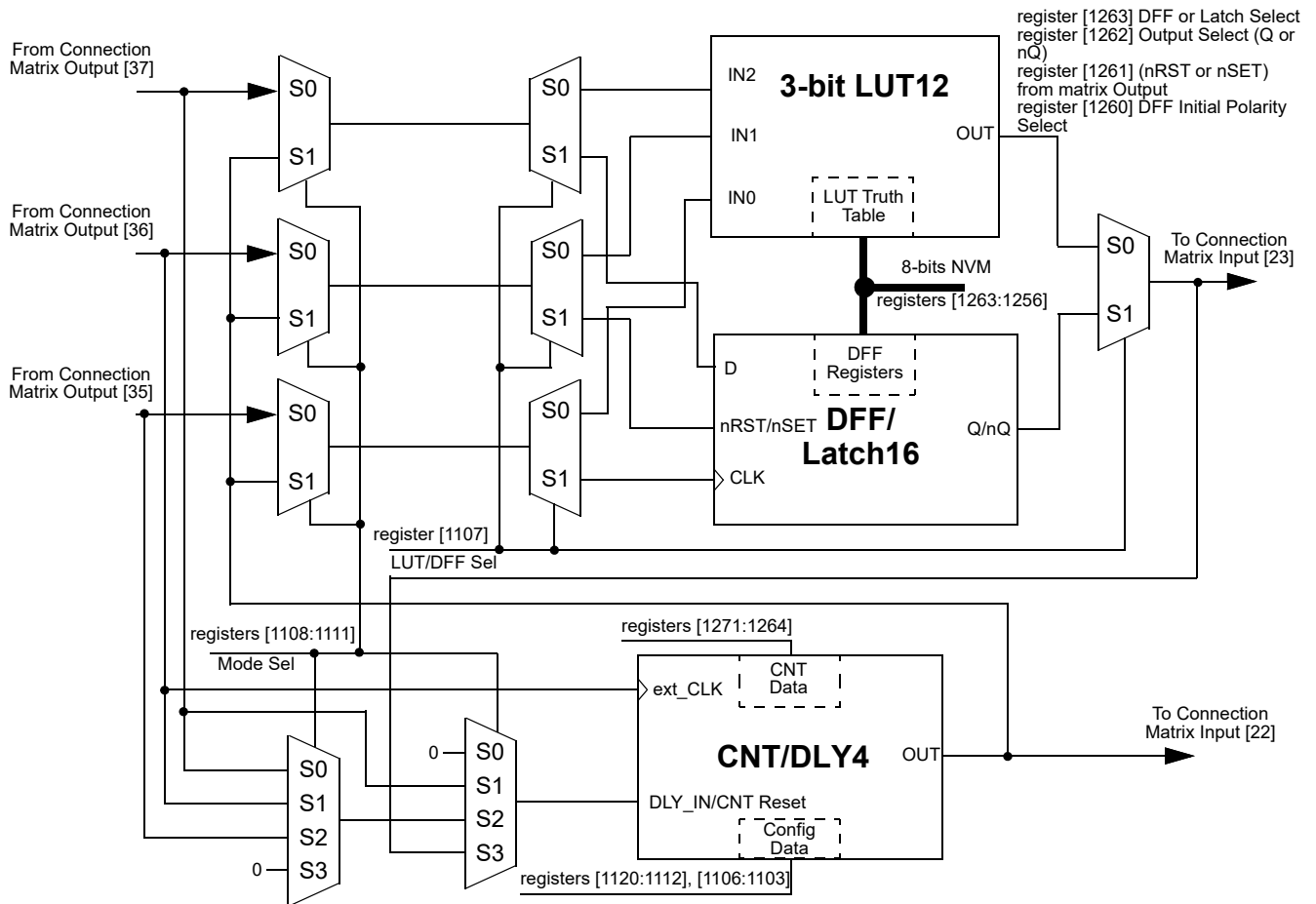

Figure 43: 8-bit Multi-Function Macrocells Block Diagram (3-bit LUT12/DFF16, CNT/DLY4)

SLG46855-A

Auto AEC-Q100 Qualified GreenPAK Programmable Mixed-Signal Matrix

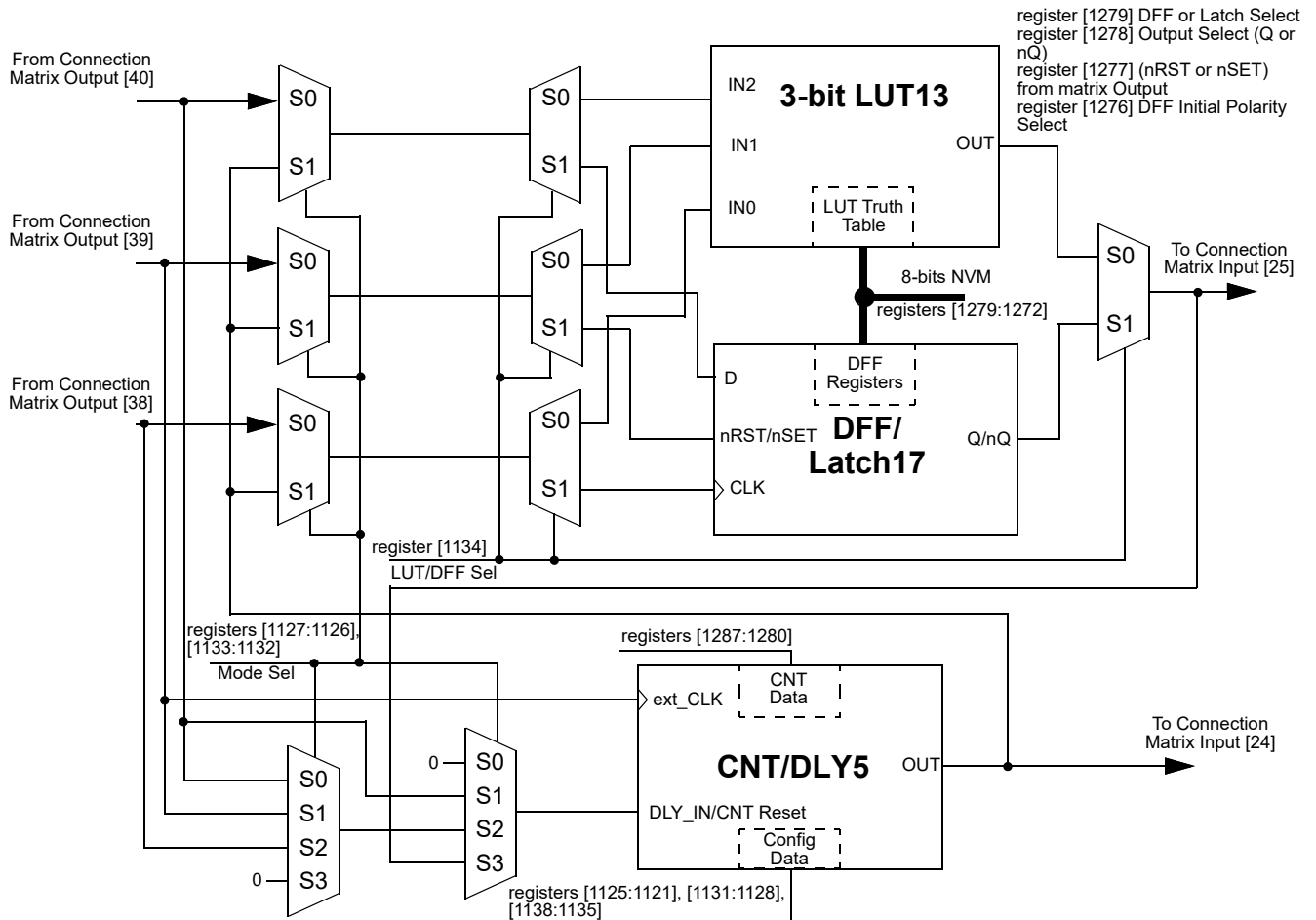

Figure 44: 8-bit Multi-Function Macrocells Block Diagram (3-bit LUT13/DFF17, CNT/DLY5)

SLG46855-A

Auto AEC-Q100 Qualified GreenPAK Programmable Mixed-Signal Matrix

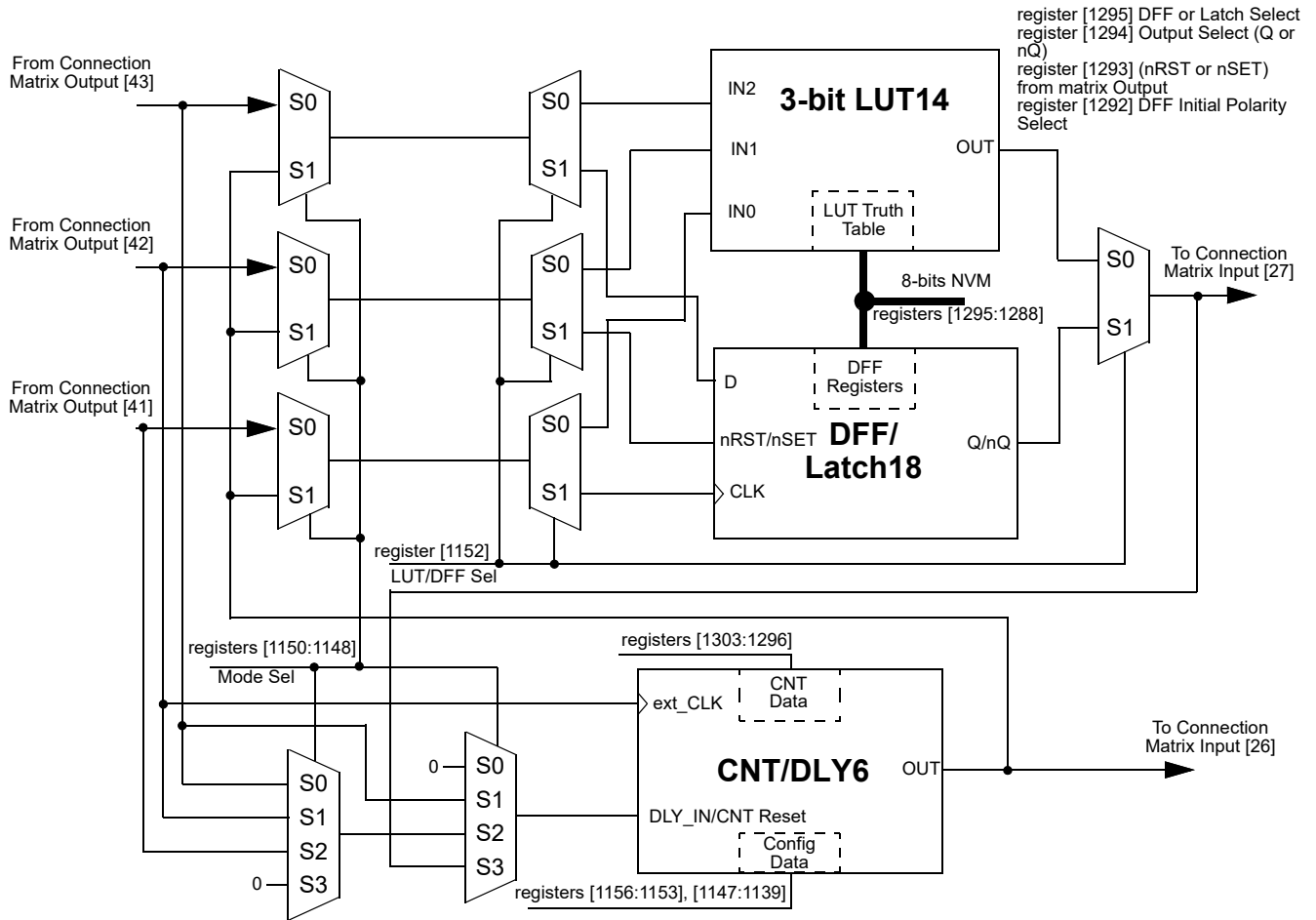

Figure 45: 8-bit Multi-Function Macrocells Block Diagram (3-bit LUT14/DFF18, CNT/DLY6)

Auto AEC-Q100 Qualified GreenPAK Programmable Mixed-Signal Matrix

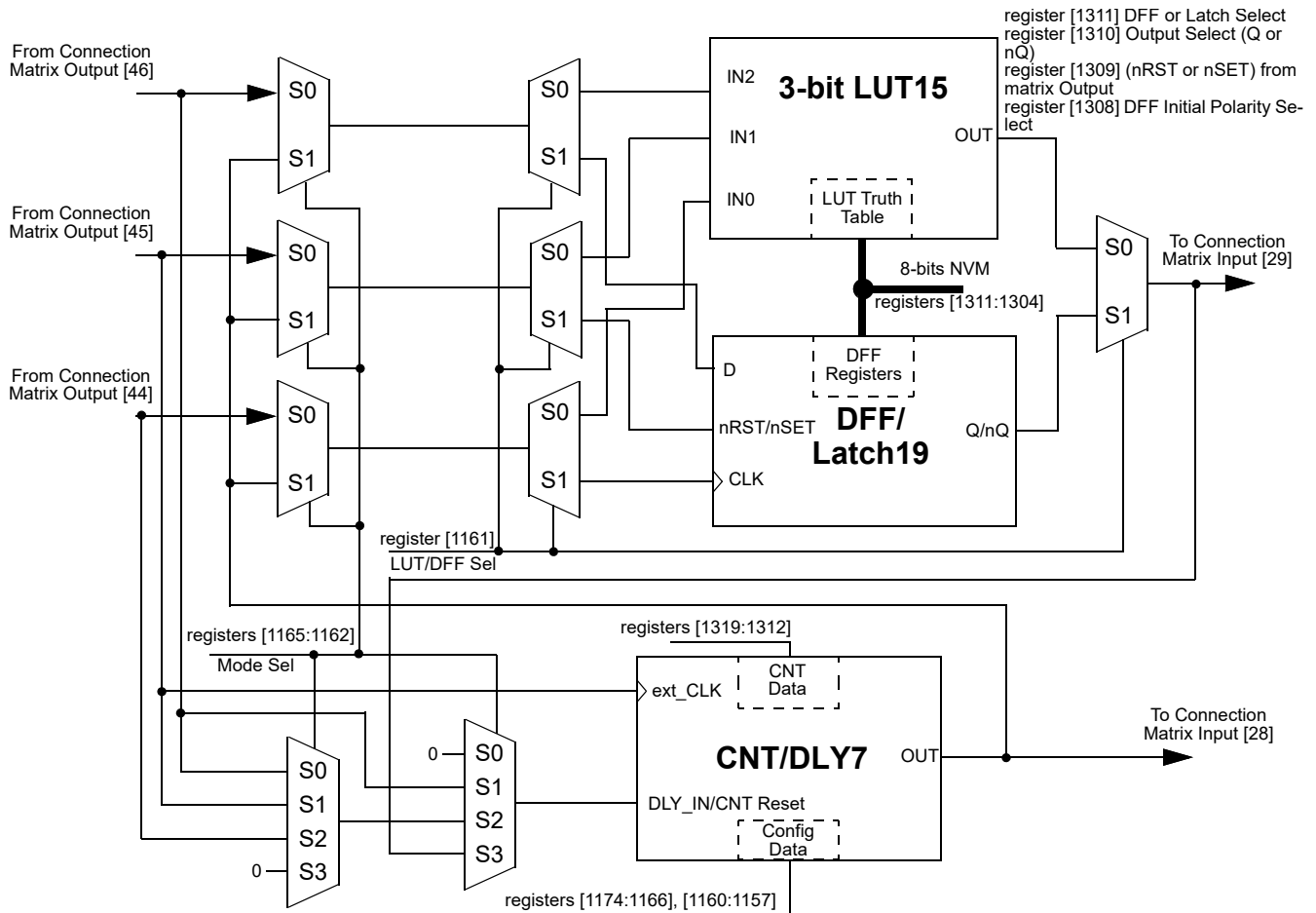

Figure 46: 8-bit Multi-Function Macrocells Block Diagram (3-bit LUT15/DFF19, CNT/DLY7)

As shown in Figures 24-30 there is a possibility to use LUT/DFF and CNT/DLY simultaneously.

**Note:** It is not possible to use LUT and DFF at once, one of these macrocells must be selected.

- Case 1. LUT/DFF in front of CNT/DLY. Three input signals from the connection matrix go to previously selected LUT or DFF's inputs and produce a single output which goes to a CNT/DLY input. In its turn Counter/Delay's output goes back to the matrix.
- Case 2. CNT/DLY in front of LUT/DFF. Two input signals from the connection matrix go to CNT/DLY's inputs (IN and CLK). Its output signal can be connected to any input of previously selected LUT or DFF, after which the signal goes back to the matrix.
- Case 3. Single LUT/DFF or CNT/DLY. Also, it is possible to use a standalone LUT/DFF or CNT/DLY. In this case, all inputs and output of the macrocell are connected to the matrix.

# SLG46855-A

## Auto AEC-Q100 Qualified GreenPAK Programmable Mixed-Signal Matrix

### 8.1.2 3-Bit LUT or CNT/DLYs Used as 3-Bit LUTs

**Table 45: 3-bit LUT9 Truth Table**

IN2	IN1	IN0	OUT	
0	0	0	register [1208]	LSB
0	0	1	register [1209]	
0	1	0	register [1210]	
0	1	1	register [1211]	
1	0	0	register [1212]	
1	0	1	register [1213]	
1	1	0	register [1214]	
1	1	1	register [1215]	MSB

**Table 46: 3-bit LUT10 Truth Table**

IN2	IN1	IN0	OUT	
0	0	0	register [1224]	LSB
0	0	1	register [1225]	
0	1	0	register [1226]	
0	1	1	register [1227]	
1	0	0	register [1228]	
1	0	1	register [1229]	
1	1	0	register [1230]	
1	1	1	register [1231]	MSB

**Table 47: 3-bit LUT11 Truth Table**

IN2	IN1	IN0	OUT	
0	0	0	register [1240]	LSB
0	0	1	register [1241]	
0	1	0	register [1242]	
0	1	1	register [1243]	
1	0	0	register [1244]	
1	0	1	register [1245]	
1	1	0	register [1246]	
1	1	1	register [1247]	MSB

**Table 48: 3-bit LUT12 Truth Table**

IN2	IN1	IN0	OUT	
0	0	0	register [1256]	LSB
0	0	1	register [1257]	
0	1	0	register [1258]	
0	1	1	register [1259]	
1	0	0	register [1260]	
1	0	1	register [1261]	
1	1	0	register [1262]	
1	1	1	register [1263]	MSB

**Table 49: 3-bit LUT13 Truth Table**

IN2	IN1	IN0	OUT	
0	0	0	register [1272]	LSB
0	0	1	register [1273]	
0	1	0	register [1274]	
0	1	1	register [1275]	
1	0	0	register [1276]	
1	0	1	register [1277]	
1	1	0	register [1278]	
1	1	1	register [1279]	MSB

**Table 50: 3-bit LUT14 Truth Table**

IN2	IN1	IN0	OUT	
0	0	0	register [1288]	LSB
0	0	1	register [1289]	
0	1	0	register [1290]	
0	1	1	register [1291]	
1	0	0	register [1292]	
1	0	1	register [1293]	
1	1	0	register [1294]	
1	1	1	register [1295]	MSB

**Table 51: 3-bit LUT15 Truth Table**

IN2	IN1	IN0	OUT	
0	0	0	register [1304]	LSB
0	0	1	register [1305]	
0	1	0	register [1306]	
0	1	1	register [1307]	
1	0	0	register [1308]	
1	0	1	register [1309]	
1	1	0	register [1310]	
1	1	1	register [1311]	MSB

## Auto AEC-Q100 Qualified GreenPAK Programmable Mixed-Signal Matrix

Each macrocell, when programmed for a LUT function, uses a 8-bit register to define their output function:

*3-Bit LUT9 is defined by registers [1215:1208]*

*3-Bit LUT10 is defined by registers [1231:1224]*

*3-Bit LUT11 is defined by registers [1247:1240]*

*3-Bit LUT12 is defined by registers [1263:1256]*

*3-Bit LUT13 is defined by registers [1279:1272]*

*3-Bit LUT14 is defined by registers [1295:1288]*

*3-Bit LUT15 is defined by registers [1311:1304]*

## Auto AEC-Q100 Qualified GreenPAK Programmable Mixed-Signal Matrix

### 8.2 4-BIT LUT OR DFF/LATCH WITH 16-BIT COUNTER/DELAY MACROCELL

There is one macrocell that can serve as either 4-bit LUT/D Flip-Flops or as 16-bit Counter/Delay.

When used to implement LUT function, the 4-bit LUT takes in four input signals from the Connection Matrix and produces a single output, which goes back into the Connection Matrix.

When used to implement D Flip-Flop function, the two input signals from the connection matrix go to the data (D) and clock (CLK) inputs for the Flip-Flop, with the output going back to the connection matrix.

When used to implement 16-Bit Counter/Delay function, two of the four input signals from the connection matrix go to the external clock (EXT\_CLK) and reset (DLY\_IN/CNT Reset) for the Counter/Delay, with the output going back to the connection matrix.

This macrocell has an optional Finite State Machine (FSM) function. There are two additional matrix inputs for Up and Keep to support FSM functionality

This macrocell can also operate in a one-shot mode, which will generate an output pulse of user-defined width.

This macrocell can also operate in a frequency detection or edge detection mode.

This macrocell can have its active count value read via I<sup>2</sup>C. See Section 15.6.1 for further details.

**Note:** After two DFF – counters initialize with counter data = 0 after POR.

Initial state = 1 – counters initialize with counter data = 0 after POR.

Initial state = 0 And After two DFF is bypass – counters initialize with counter data after POR.



SLG46855-A

Auto AEC-Q100 Qualified GreenPAK Programmable Mixed-Signal Matrix

8.2.1 4-Bit LUT or DFF/LATCH with 16-Bit CNT/DLY Block Diagram

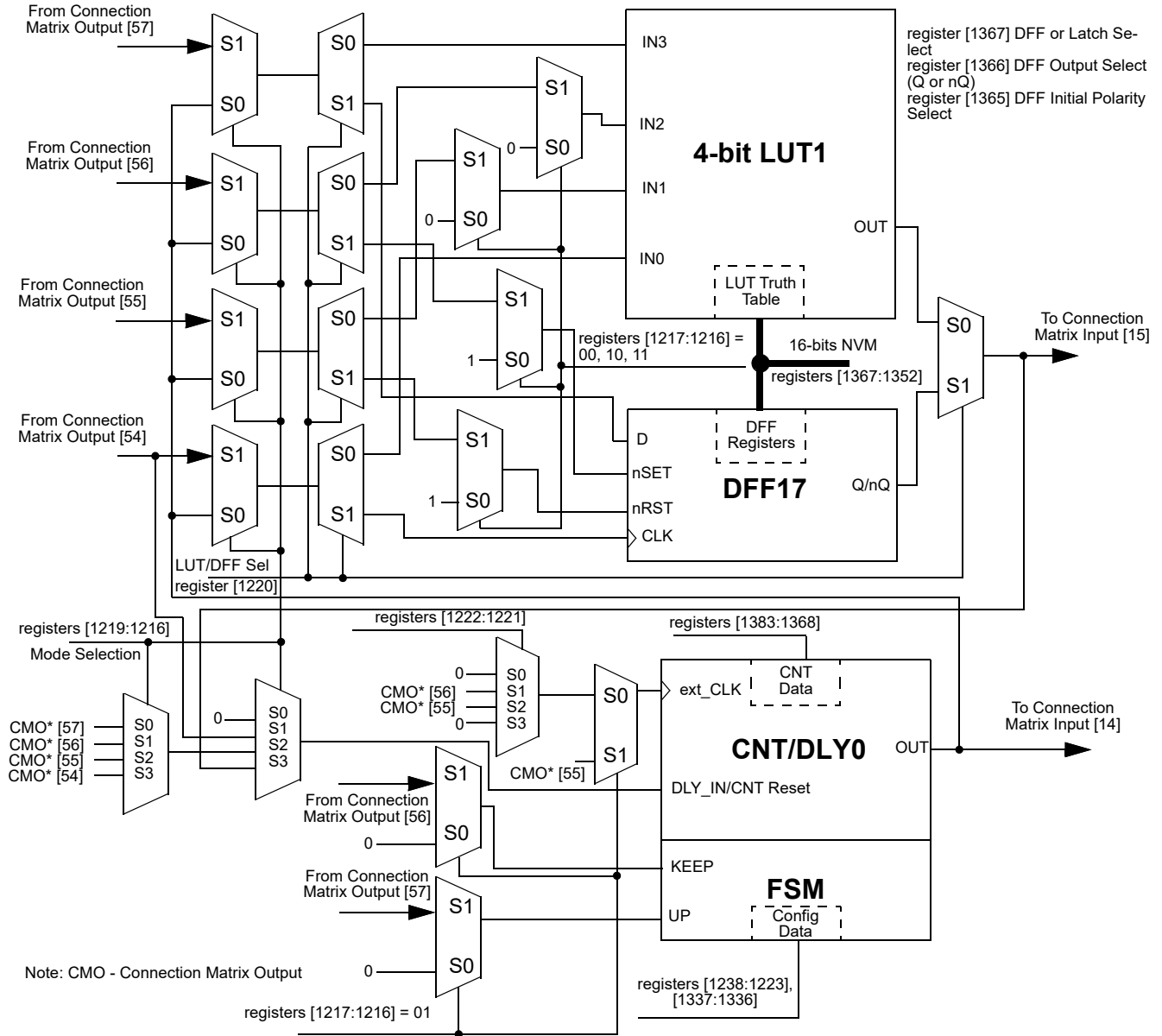

Figure 47: 4-bit LUT1 or CNT/DLY0

# SLG46855-A

## Auto AEC-Q100 Qualified GreenPAK Programmable Mixed-Signal Matrix

### 8.2.2 4-Bit LUT or 16-Bit Counter/Delay Macrocells Used as 4-Bit LUTs

**Table 52: 4-bit LUT1 Truth Table**

IN3	IN2	IN1	IN0	OUT	
0	0	0	0	register [1176]	LSB
0	0	0	1	register [1177]	
0	0	1	0	register [1178]	
0	0	1	1	register [1179]	
0	1	0	0	register [1180]	
0	1	0	1	register [1181]	
0	1	1	0	register [1182]	
0	1	1	1	register [1183]	
1	0	0	0	register [1184]	
1	0	0	1	register [1185]	
1	0	1	0	register [1186]	
1	0	1	1	register [1187]	
1	1	0	0	register [1188]	
1	1	0	1	register [1189]	
1	1	1	0	register [1190]	
1	1	1	1	register [1191]	MSB

This macrocell, when programmed for a LUT function, uses a 16-bit register to define their output function:

*4-Bit LUT1 is defined by registers [1191:1176]*

**Table 53: 4-bit LUT Standard Digital Functions**

Function	MSB															LSB
AND-4	1	0	0	0	0	0	0	0	0	0	0	0	0	0	0	0
NAND-4	0	1	1	1	1	1	1	1	1	1	1	1	1	1	1	1
OR-4	1	1	1	1	1	1	1	1	1	1	1	1	1	1	1	0
NOR-4	0	0	0	0	0	0	0	0	0	0	0	0	0	0	0	1
XOR-4	0	1	1	0	1	0	0	1	1	1	0	0	1	1	1	0
XNOR-4	1	0	0	1	0	1	1	0	0	0	1	1	0	0	0	1

SLG46855-A

Auto AEC-Q100 Qualified GreenPAK Programmable Mixed-Signal Matrix

8.3 CNT/DLY/FSM TIMING DIAGRAMS

8.3.1 Delay Mode CNT/DLY0 to CNT/DLY7

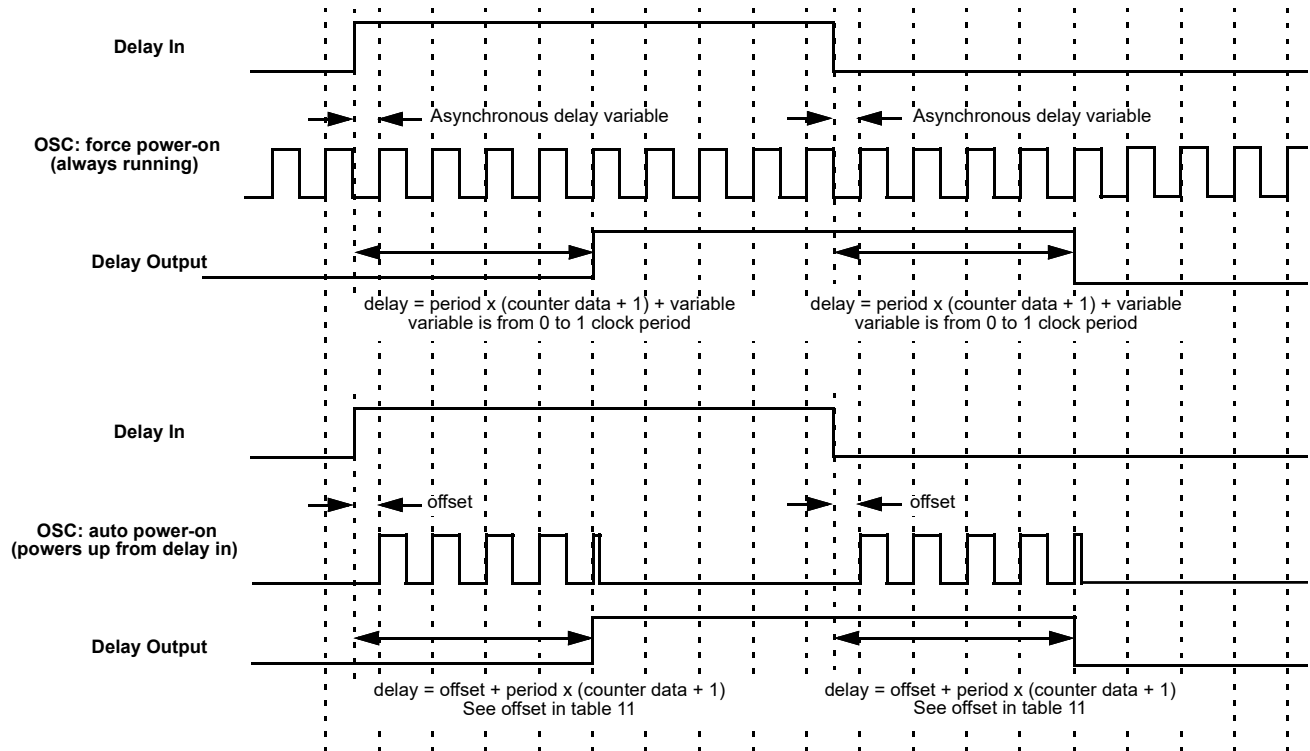

Figure 48: Delay Mode Timing Diagram, Edge Select: Both, Counter Data: 3

SLG46855-A

Auto AEC-Q100 Qualified GreenPAK Programmable Mixed-Signal Matrix

The macrocell shifts the respective edge to a set time and restarts by appropriate edge. It works as a filter, if the input signal is shorter than the delay time.

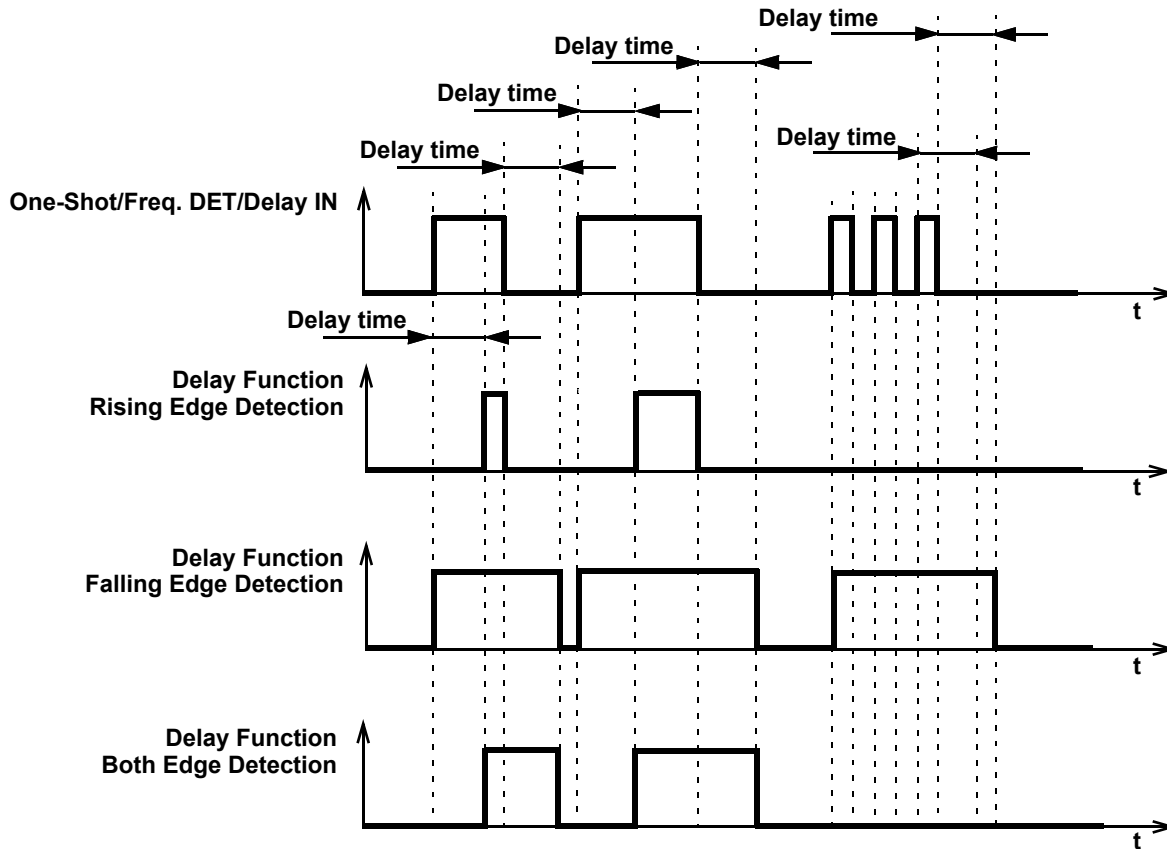

Figure 49: Delay Mode Timing Diagram for Different Edge Select Mode

8.3.2 Count Mode (Count Data: 3), Counter Reset (Rising Edge Detect) CNT/DLY0 to CNT/DLY7

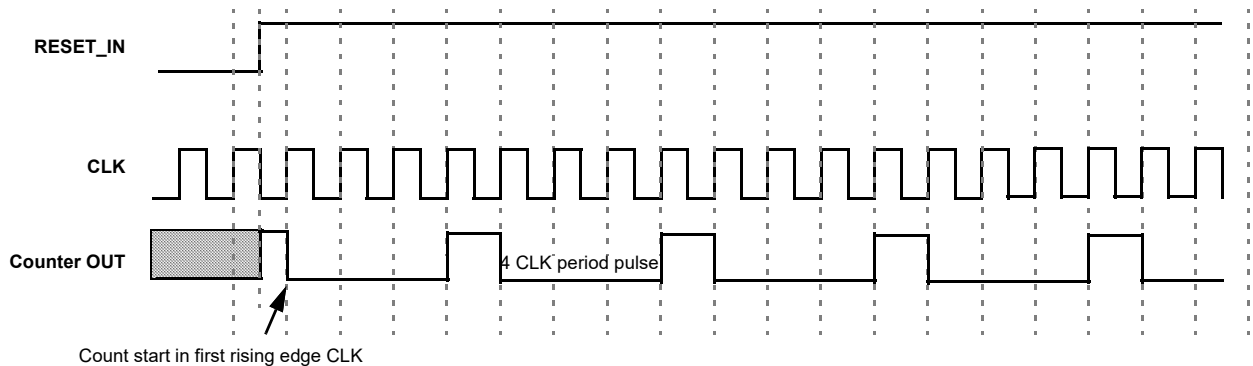

Figure 50: Counter Mode Timing Diagram without Two DFFs Synced Up

SLG46855-A

Auto AEC-Q100 Qualified GreenPAK Programmable Mixed-Signal Matrix

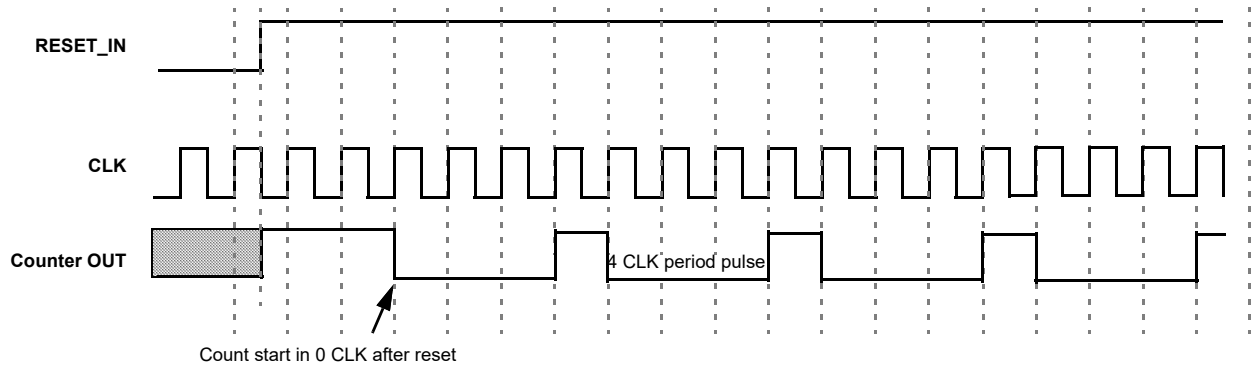

Figure 51: Counter Mode Timing Diagram with Two DFFs Synced Up

SLG46855-A

Auto AEC-Q100 Qualified GreenPAK Programmable Mixed-Signal Matrix

8.3.3 One-Shot Mode CNT/DLY0 to CNT/DLY7

This macrocell will generate a pulse whenever a selected edge is detected on its input. Register bits set the edge selection. The pulse width determines by counter data and clock selection properties. The output pulse polarity (non-inverted or inverted) is selected by register bit. Any incoming edges will be ignored during the pulse width generation. The following diagram shows one-shot function for non-inverted output.

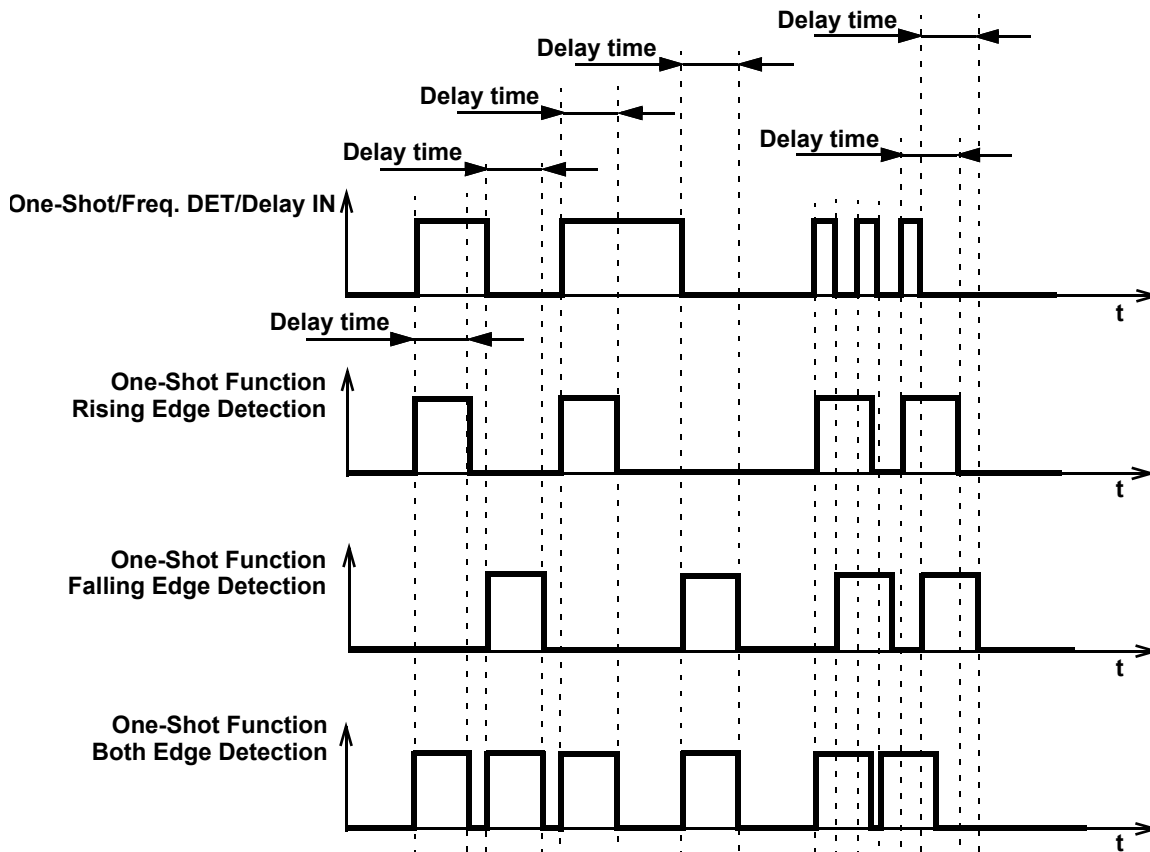

Figure 52: One-Shot Function Timing Diagram

This macrocell generates a high level pulse with a set width (defined by counter data) when detecting the respective edge. It does not restart while pulse is high.

8.3.4 Frequency Detection Mode CNT/DLY0 to CNT/DLY7

Rising Edge: The output goes high if the time between two successive edges is less than the delay. The output goes low if the second rising edge has not come after the last rising edge in specified time.

Falling Edge: The output goes high if the time between two falling edges is less than the set time. The output goes low if the second falling edge has not come after the last falling edge in specified time.

Both Edge: The output goes high if the time between the rising and falling edges is less than the set time, which is equivalent to the length of the pulse. The output goes low if after the last rising/falling edge and specified time, the second edge has not come.

SLG46855-A

Auto AEC-Q100 Qualified GreenPAK Programmable Mixed-Signal Matrix

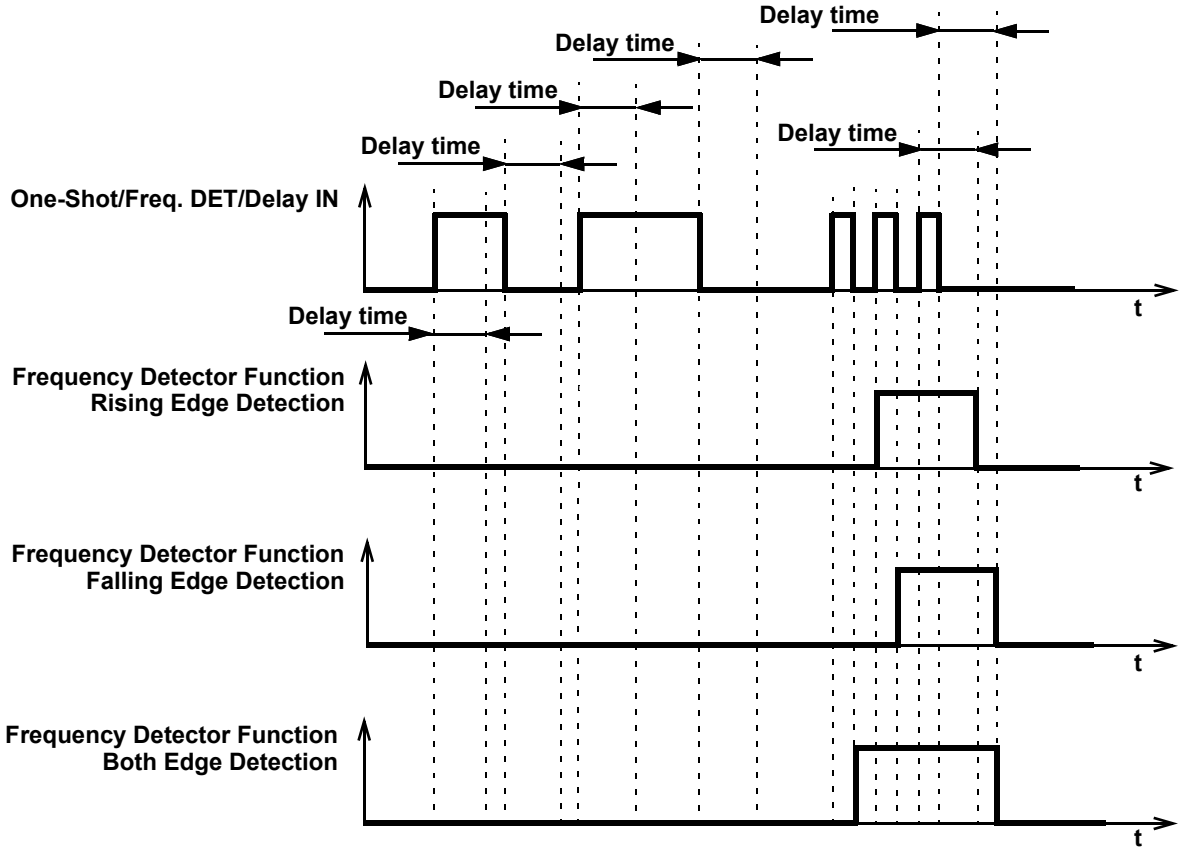

Figure 53: Frequency Detection Mode Timing Diagram

SLG46855-A

Auto AEC-Q100 Qualified GreenPAK Programmable Mixed-Signal Matrix

8.3.5 Edge Detection Mode CNT/DLY1 to CNT/DLY7

The macrocell generates high level short pulse when detecting the respective edge. See Table 12.

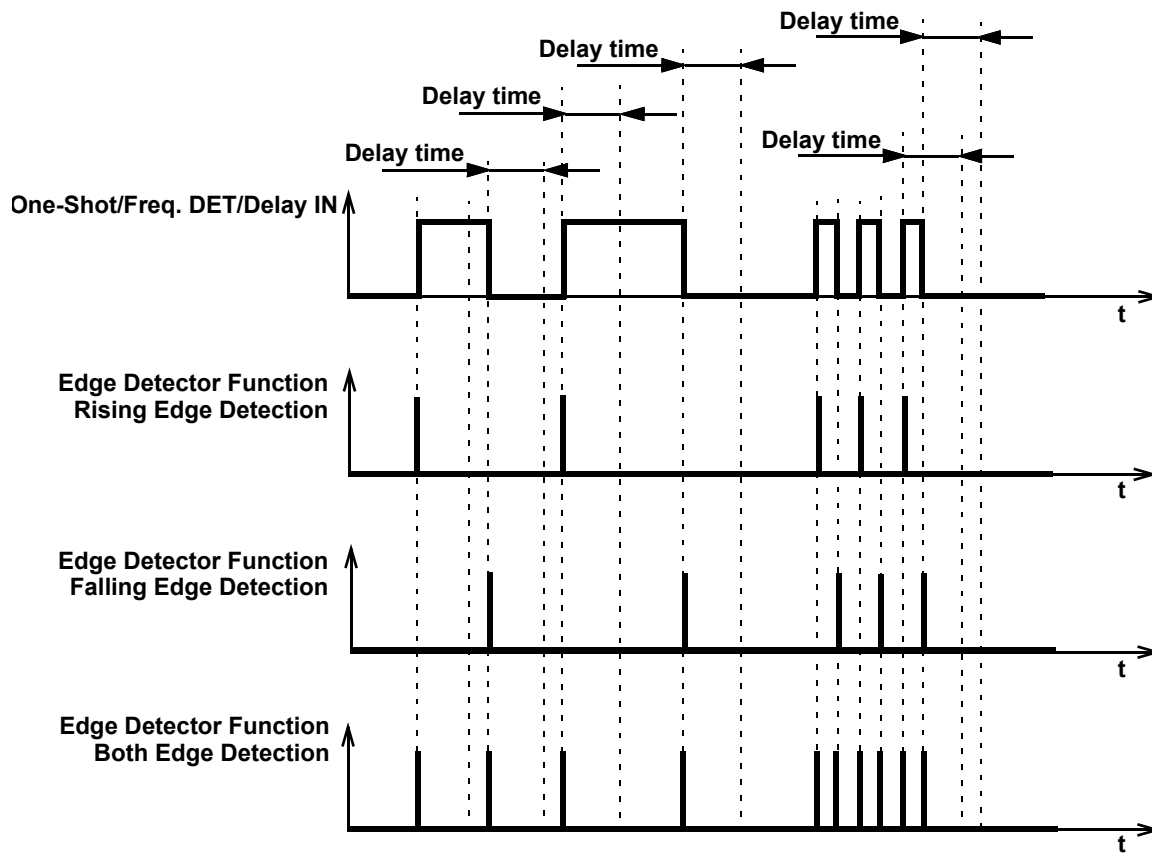

Figure 54: Edge Detection Mode Timing Diagram



SLG46855-A

Auto AEC-Q100 Qualified GreenPAK Programmable Mixed-Signal Matrix

8.3.6 Delayed Edge Detection Mode CNT/DLY0 to CNT/DLY7

In Delayed Edge Detection Mode, High level short pulses are generated on the macrocell output after the configured delay time, if the corresponding edge was detected on the input.

If the input signal is changed during the set delay time, the pulse will not be generated. See Figure 55.

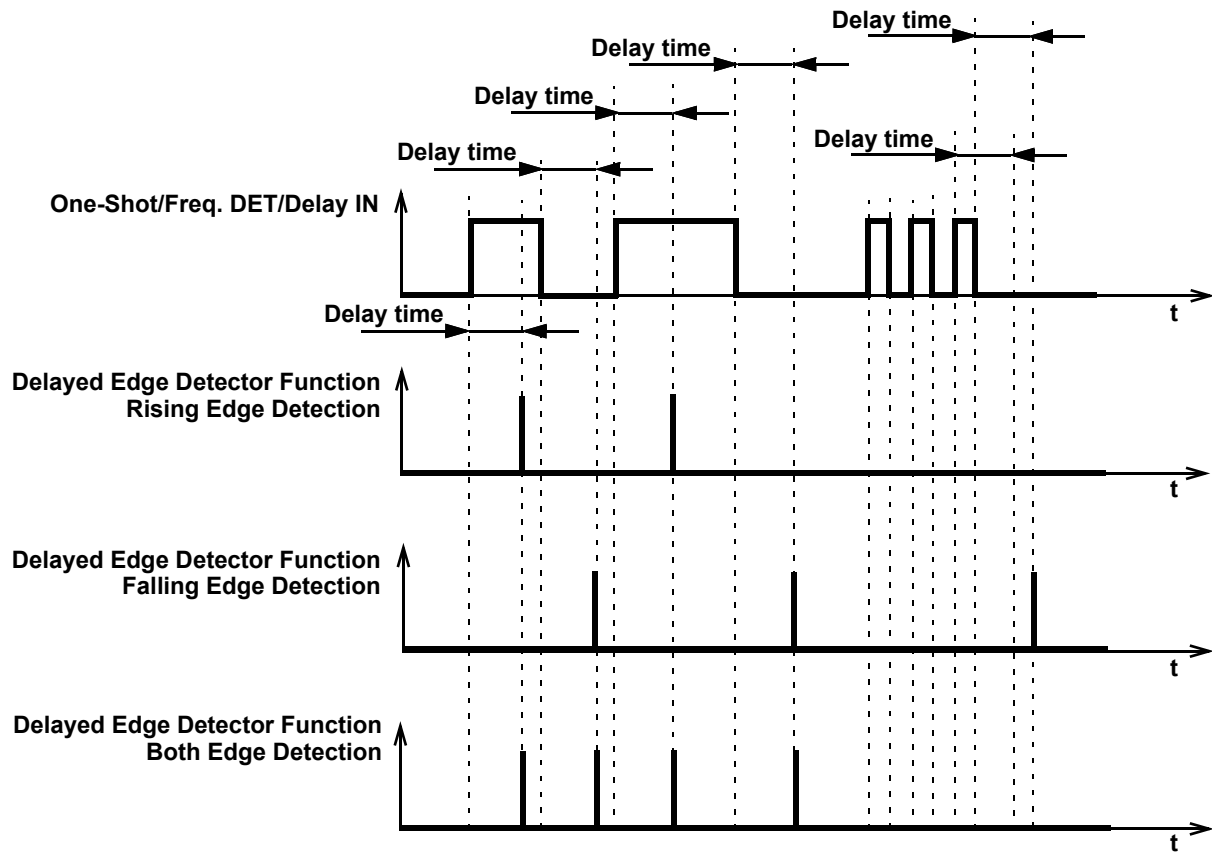

Figure 55: Delayed Edge Detection Mode Timing Diagram

SLG46855-A

Auto AEC-Q100 Qualified GreenPAK Programmable Mixed-Signal Matrix

8.3.7 CNT/FSM Mode CNT/DLY0

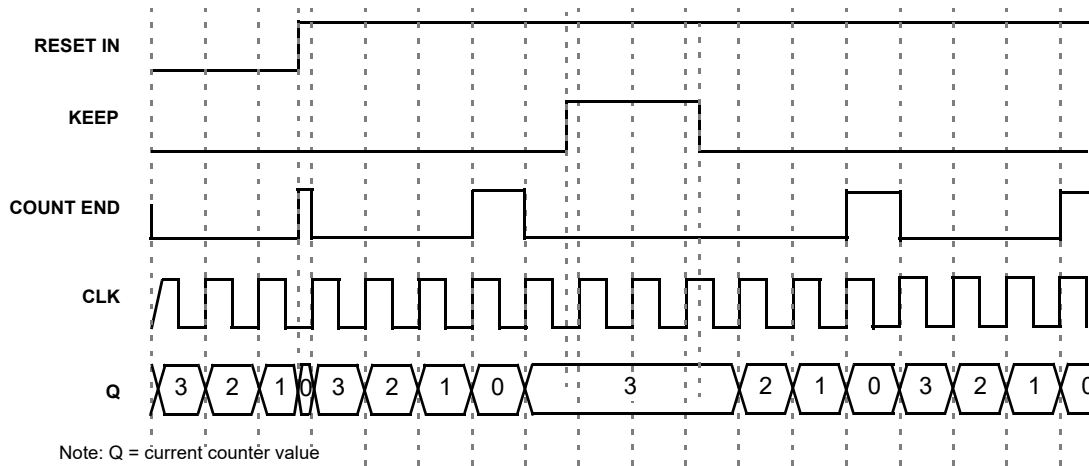

Figure 56: CNT/FSM Timing Diagram (Reset Rising Edge Mode, Oscillator is Forced On, UP = 0) for Counter Data = 3

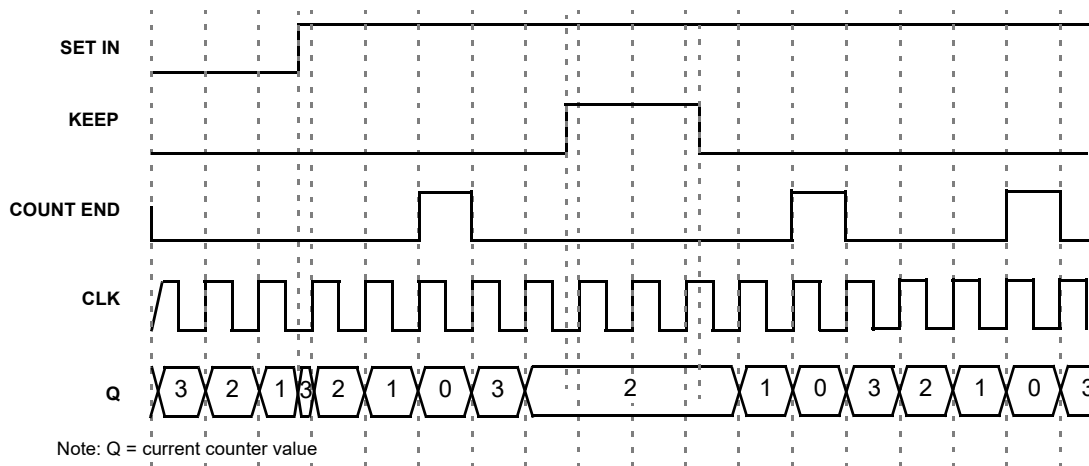

Figure 57: CNT/FSM Timing Diagram (Set Rising Edge Mode, Oscillator is Forced On, UP = 0) for Counter Data = 3

SLG46855-A

Auto AEC-Q100 Qualified GreenPAK Programmable Mixed-Signal Matrix

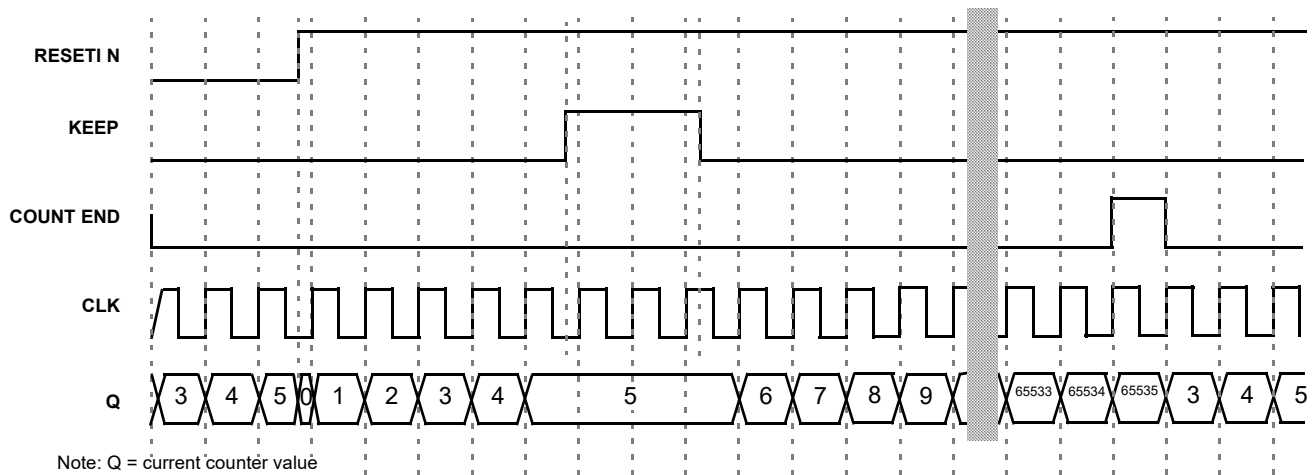

Figure 58: CNT/FSM Timing Diagram (Reset Rising Edge Mode, Oscillator is Forced On, UP = 1) for Counter Data = 3

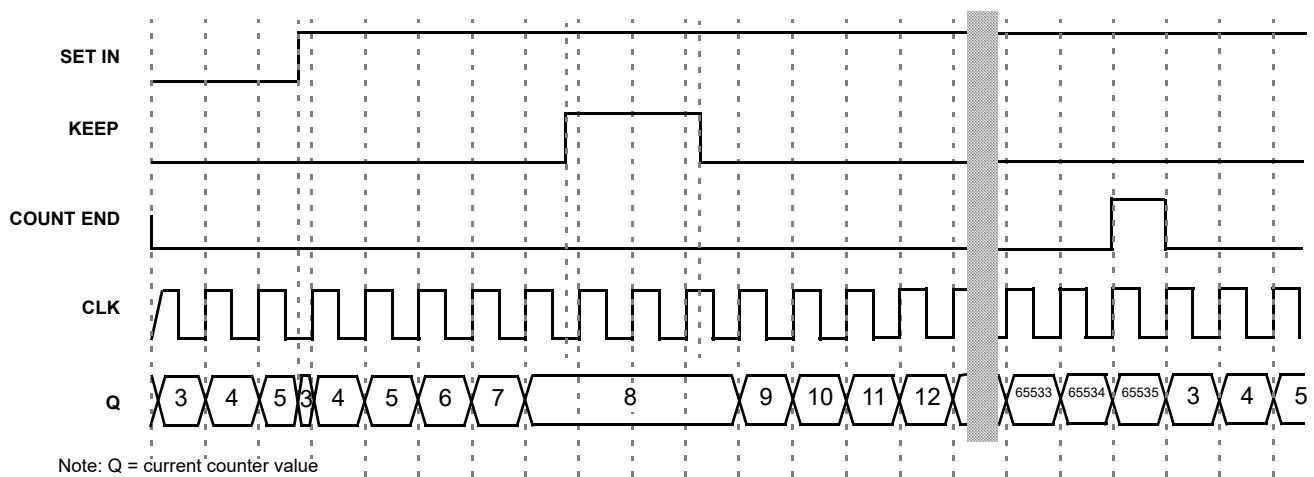

Figure 59: CNT/FSM Timing Diagram (Set Rising Edge Mode, Oscillator is Forced On, UP = 1) for Counter Data = 3

SLG46855-A

Auto AEC-Q100 Qualified GreenPAK Programmable Mixed-Signal Matrix

8.3.8 Difference in Counter Value for Counter, Delay, One-Shot, and Frequency Detect Modes

There is a difference in counter value for Counter and Delay/One-Shot/Frequency Detect modes. The counter value is shifted for two rising edges of the clock signal in Delay/One-Shot/Frequency Detect modes compared to Counter mode. See Figure 60:

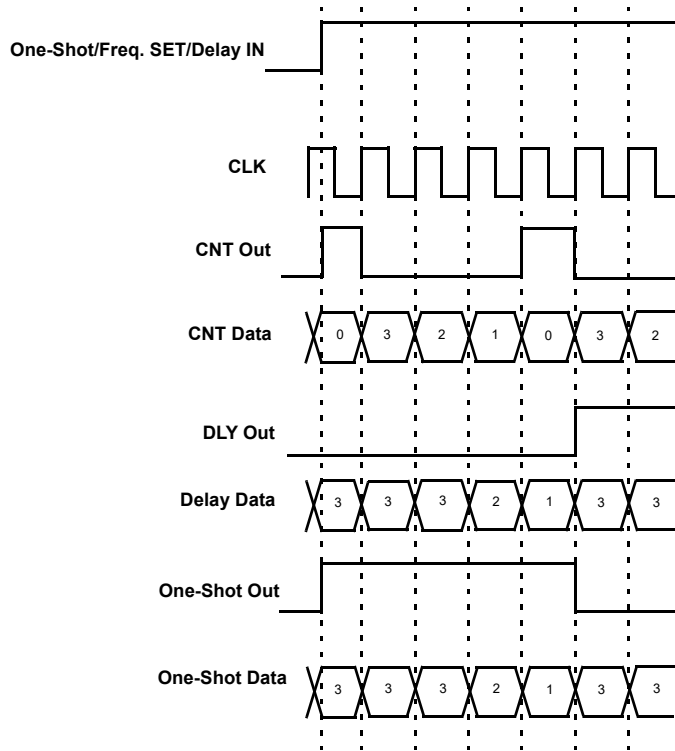

Figure 60: Counter Value, Counter Data = 3

8.4 WAKE AND SLEEP CONTROLLER

The SLG46855-A has a Wake and Sleep function for all ACMPs. The macrocell CNT/DLY0 can be reconfigured for this purpose registers [1032:1031] = 11 and register [1046] = 1. The WS serves for power saving, it allows to switch on and off selected ACMPs on selected bit of 16-bit counter.

**Note 1:** BG/Analog\_Good time is long and should be considered in wake and sleep timing in case it dynamically powers on/off.

SLG46855-A

Auto AEC-Q100 Qualified GreenPAK Programmable Mixed-Signal Matrix

**Note 2:** Wake time should be long enough to make sure ACMP and Vref have enough time to get a sample before going to sleep.

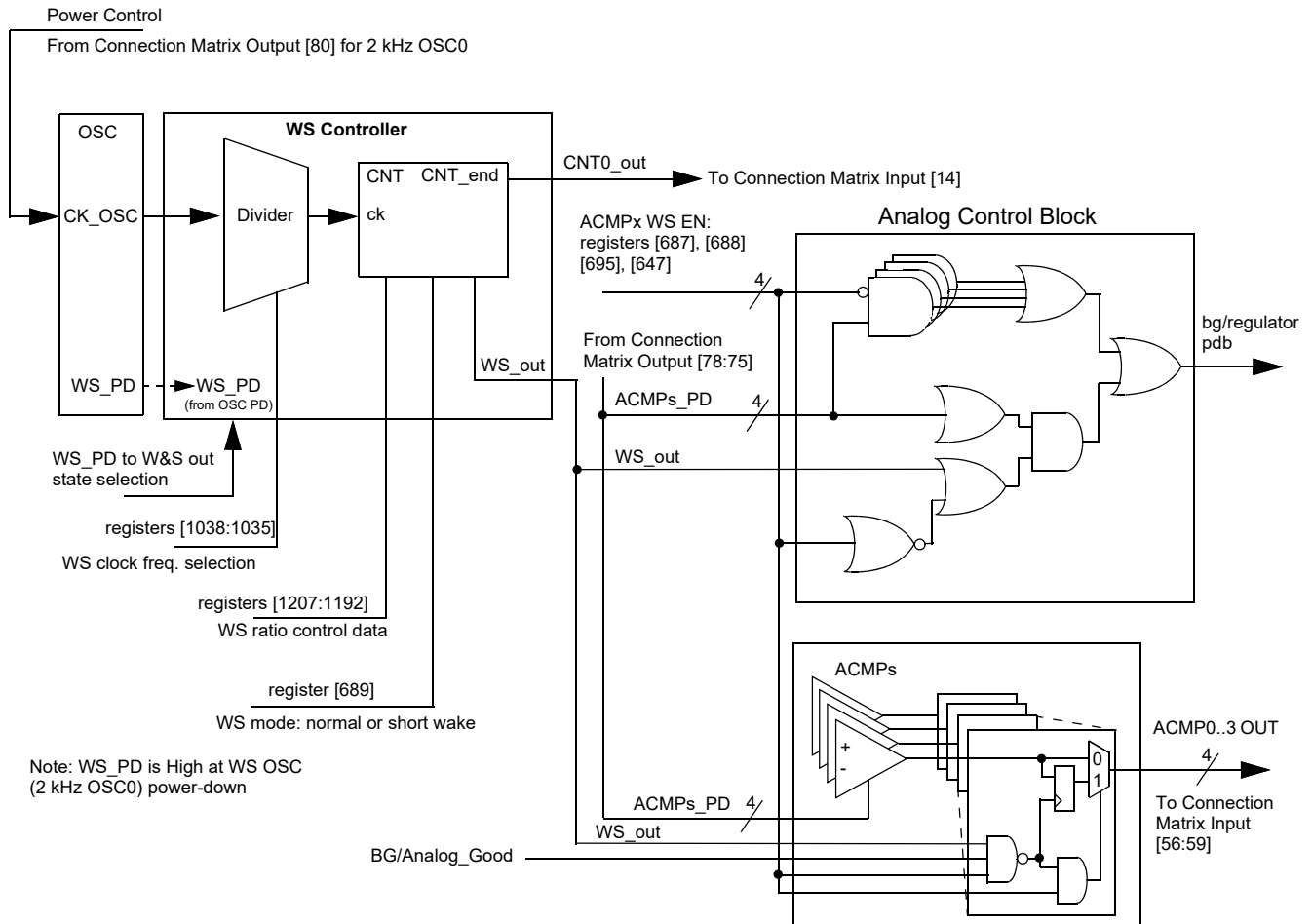
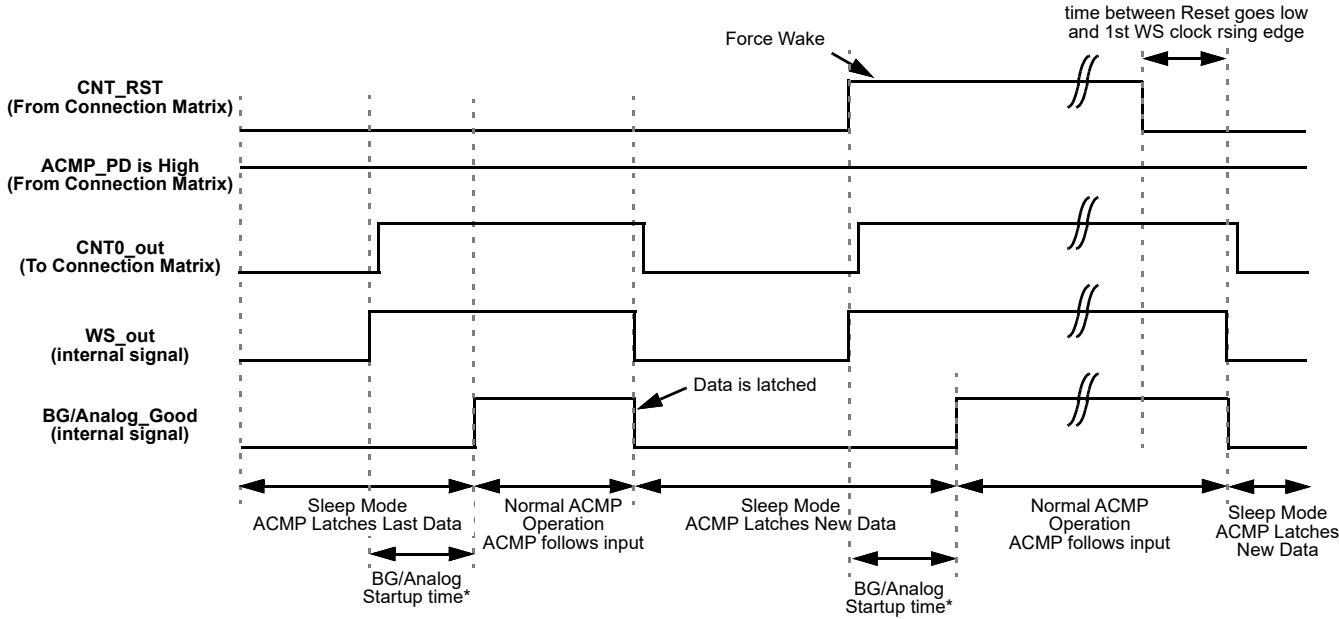

Figure 61: Wake/Sleep Controller

SLG46855-A

Auto AEC-Q100 Qualified GreenPAK Programmable Mixed-Signal Matrix



Note: CNT0\_out is a delayed WS\_out signal for 1us to make sure the data is correct during LATCH.

Figure 62: Wake/Sleep Timing Diagram, Normal Wake Mode, Counter Reset is Used

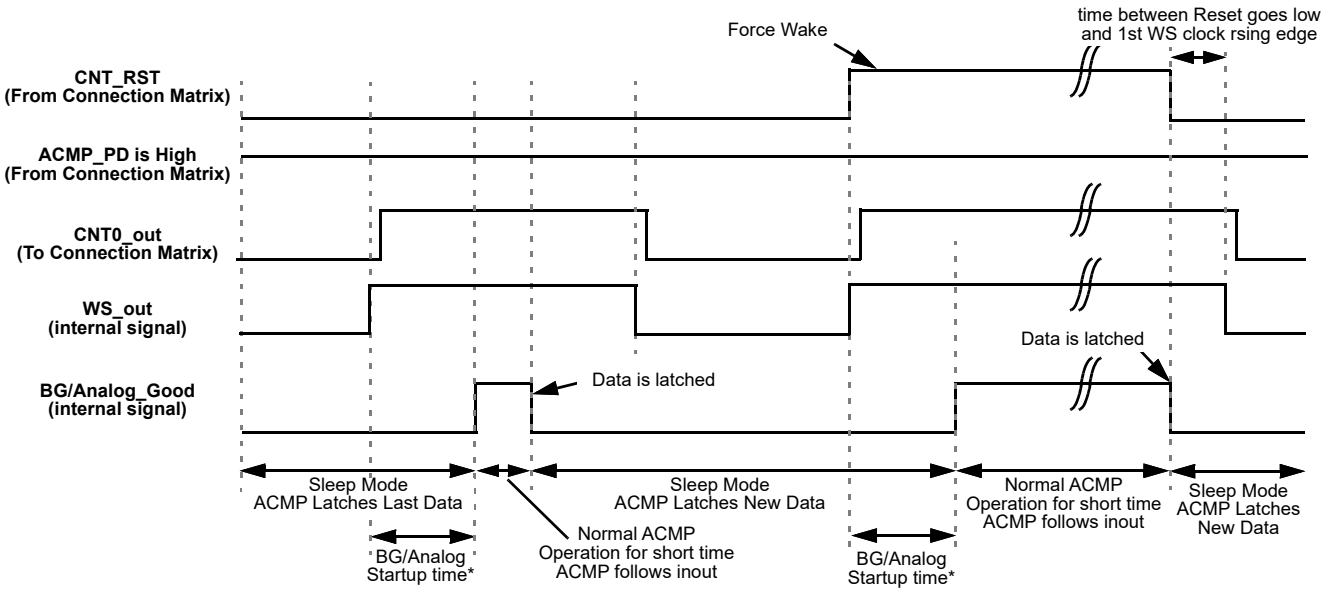

Note: CNT0\_out is a delayed WS\_out signal for 1us to make sure the data is correct during LATCH.

Figure 63: Wake/Sleep Timing Diagram, Short Wake Mode, Counter Reset is Used

SLG46855-A

Auto AEC-Q100 Qualified GreenPAK Programmable Mixed-Signal Matrix

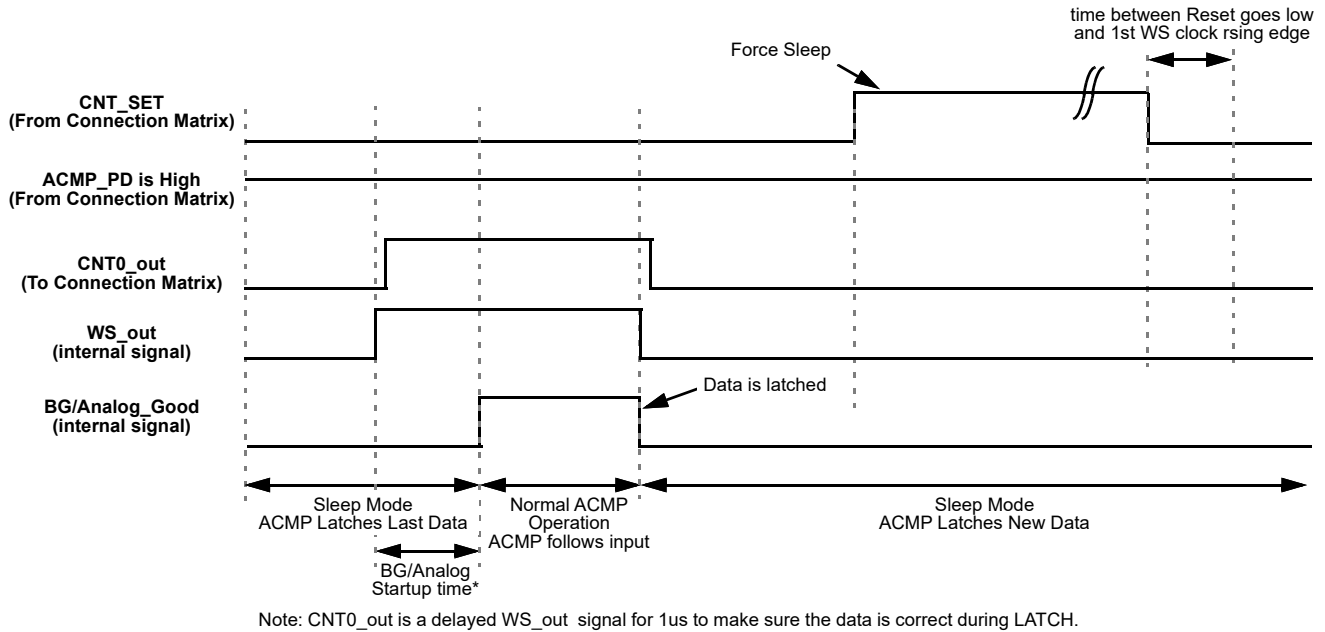

Figure 64: Wake/Sleep Timing Diagram, Normal Wake Mode, Counter Set is Used

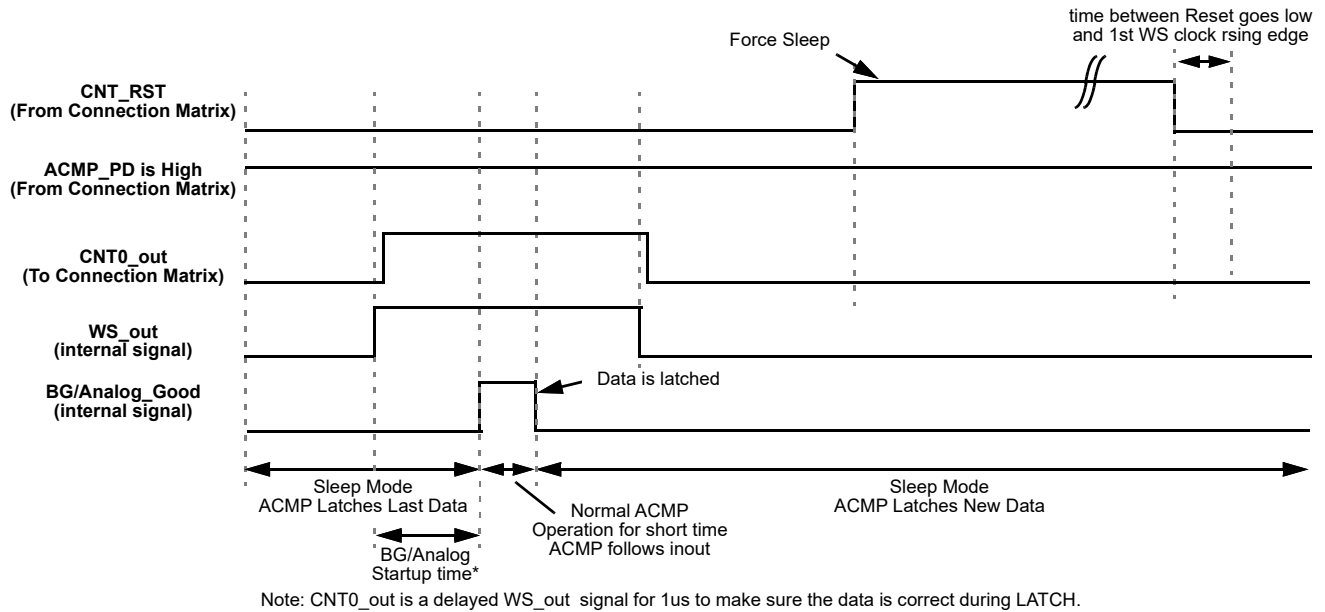

Figure 65: Wake/Sleep Timing Diagram, Short Wake Mode, Counter Set is Used

**Note:** If low power BG is powered on/off by WS, the wake time should be longer than 2.1 ms. The BG/analog start up time will take maximal 2 ms. Therefore, 8 periods of the Oscillator0 is recommended for the wake time, when BG is configured to Auto Power mode. If low power BG is always on, Oscillator0 period is longer than required wake time. The BG/analog start up time will

## Auto AEC-Q100 Qualified GreenPAK Programmable Mixed-Signal Matrix

take maximal 450 us for ACMP0/1 and a shorter time for ACMP2/3. The short wake mode can be used to reduce the current consumption.

To use any ACMP under WS controller, the following settings must be done:

- ACMP Power Up Input from matrix = 1 (for each ACMP separately);
- CNT/DLY0 must be set to Wake and Sleep Controller function (for all ACMP);
- Register WS → enable (for each ACMP separately);
- CNT/DLY0 set/reset input = 0 (for all ACMP).

The user can select a period of time while the ACMP is sleeping in a range of 1 - 65535 clock cycles. Before they are sent to sleep their outputs are latched, so the ACMPs remain their state (High or Low) while sleeping.

WS controller has the following settings:

- Wake and Sleep Output State (High/Low)
  - If OSC is powered off (Power-down option is selected; Power-down input = 1) and Wake and Sleep Output State = High, the ACMP is continuously on.
  - If OSC is powered off (Power-down option is selected; Power-down input = 1) and Wake and Sleep Output State = Low, the ACMP is continuously off.
  - Both cases WS function is turned off.
- Counter Data (Range: 1 - 65535)
  - User can select wake and sleep ratio of the ACMP; counter data = sleep time, one clock = wake time.
- Q mode - defines the state of WS counter data when Set/Reset signal appears
  - Reset - when active signal appears, the WS counter will reset to zero and High level signal on its output will turn on the ACMPs. When Reset signal goes out, the WS counter will go Low and turn off the ACMP until the counter counts up to the end.
  - Set - when active signal appears, the WS counter will stop and Low level signal on its output will turn off the ACMP. When Set signal goes out, the WS counter will go on counting and High level signal will turn on the ACMP while counter is counting up to the end.

**Note:** The OSC0 matrix power-down to control ACMP WS is not supported for short wait time option.

- Edge Select defines the edge for Q mode
  - High level Set/Reset - switches mode Set/Reset when level is High

**Note:** Q mode operates only in case of "High Level Set/Reset".

- Wake time selection - time required for wake signal to turn the ACMPxH on

Normal Wake Time - when WS signal is High, it takes BG/analog start up time to turn the ACMPs on. They will stay on until WS signal is Low again. Wake time is one clock period. It should be longer than BG turn on time and minimal required comparing time of the ACMP.

Short Wake Time - when WS signal is High, it takes BG/analog start up time to turn the ACMPs on. They will stay on for 1 μs and turn off regardless of WS signal. The WS signal width does not matter.

- Keep - pauses counting while Keep = 1
- Up - reverses counting
  - If Up = 1, CNT is counting up from user selected value to 65535.
  - If Up = 0, CNT is counting down from user selected value to 0.



## 9 Analog Comparators

There are two High Speed and two Low Power Rail-to-Rail General Purpose Analog Comparators (ACMP) macrocells in the SLG46855-A. In order for the ACMP cells to be used in a GreenPAK design, the power up signals (ACMP0H PWR UP, ACMP1H PWR UP, ACMP2L PWR UP, and ACMP3L PWR UP) need to be active. By connecting to signals coming from the Connection Matrix, it is possible to have each ACMP be ON continuously, OFF continuously, or switched on periodically based on a digital signal coming from the Connection Matrix. When ACMP is powered down, its output is low.

Two of the four General Purpose Analog Comparators are optimized for high speed operation (ACMP0H and ACMP1H), and two other are optimized for low power operation (ACMP2L and ACMP3L).

Each of the ACMP cells has a positive input signal that can be provided by a variety of external sources, and can also have a selectable gain stage (1x, 0.5x, 0.33x, 0.25x) before connection to the analog comparator. The gain divider is unbuffered and has input resistance of 2 M $\Omega$  (typ) for 0.5x, 0.33x, 0.25x, and 10 G $\Omega$  for 1x. Each of the ACMP cells has a negative input signal that is either created from an internal Vref or provided by any external source (GPIO2 and GPO0). Note that the external Vref signal is filtered with a 2nd order low pass filter with 8 kHz typical bandwidth, see [Figure 66](#) to [Figure 69](#).

Input bias current < 1 nA (typ).

PWR UP = 1 => ACMP is powered up.

PWR UP = 0 => ACMP is powered down.

During power-up, the ACMP output will remain LOW, and then becomes valid in 37  $\mu$ s (max) after power up signal goes high for ACMP0H and ACMP1H, and becomes valid 294  $\mu$ s (max) after power up signal goes high for ACMP2L and ACMP3L.

Each High Speed ACMP (ACMP0H and ACMP1H) has an optional Rail-to-Rail Input Buffer, which can be used along with the Gain divider to increase ACMP input resistance. However, Input buffer will increase an input offset voltage.

Each cell also has a hysteresis selection, to offer hysteresis of (0, 32, 64, 192) mV. The hysteresis option is available when using an internal Vref only.

The ACMP0H has an additional option of connecting an internal 100  $\mu$ A current source to its positive input, register [690]. It is also possible to connect the 100  $\mu$ A current source to each next ACMP via an internal analog MUX.

ACMP0H IN+ options are GPIO4, buffered GPIO4, V<sub>DD</sub>, 100  $\mu$ A Current Source

ACMP1H IN+ options are GPIO5, buffered GPIO5, ACMP0H IN+ MUX output

ACMP2L IN+ options are GPIO6, ACMP0H IN+ MUX output, ACMP1H IN+ MUX output

ACMP3L IN+ options are GPIO7, ACMP2L IN+ MUX output, Temp Sensor OUT

SLG46855-A

Auto AEC-Q100 Qualified GreenPAK Programmable Mixed-Signal Matrix

9.1 ACMP0H BLOCK DIAGRAM

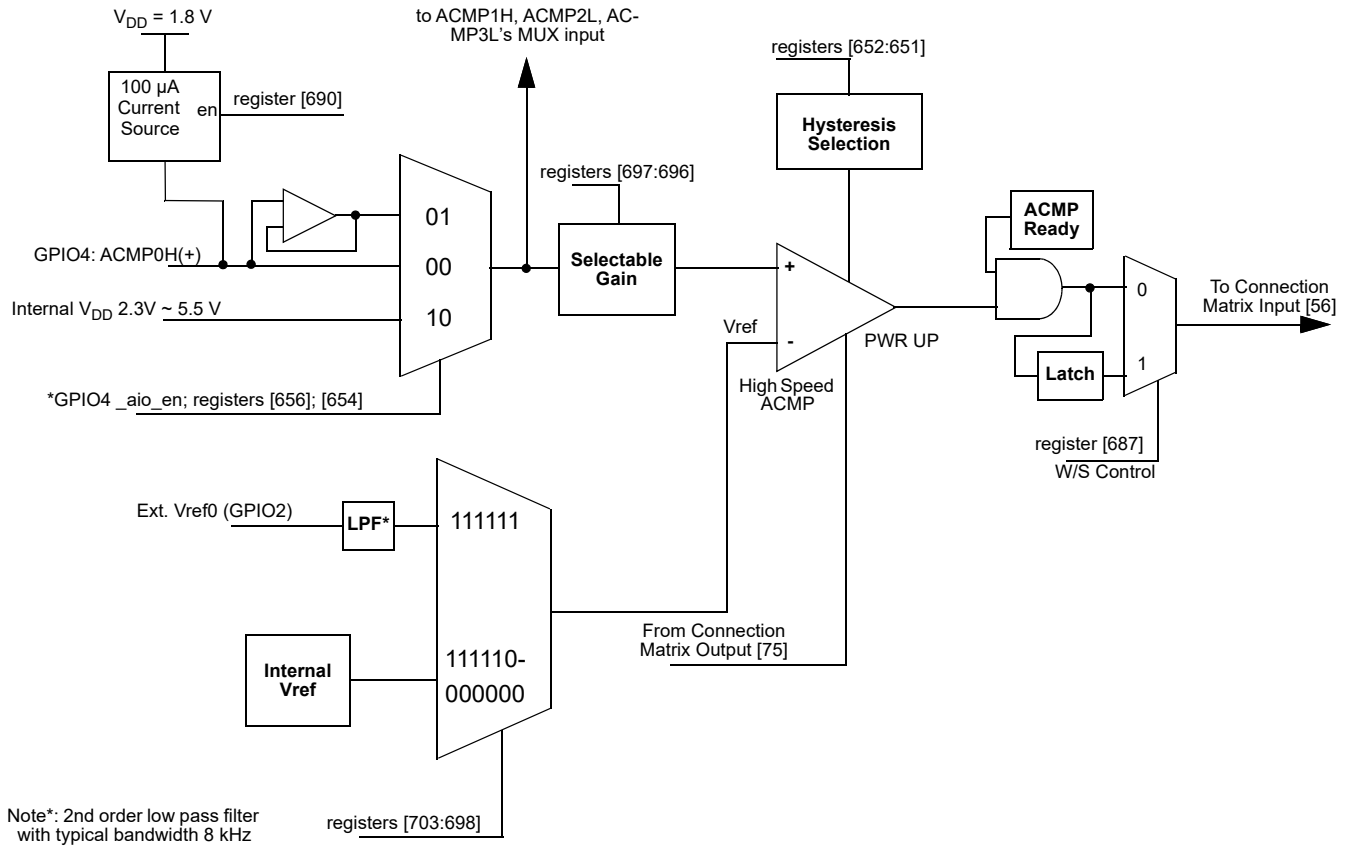

Figure 66: ACMP0H Block Diagram

SLG46855-A

Auto AEC-Q100 Qualified GreenPAK Programmable Mixed-Signal Matrix

9.2 ACMP1H BLOCK DIAGRAM

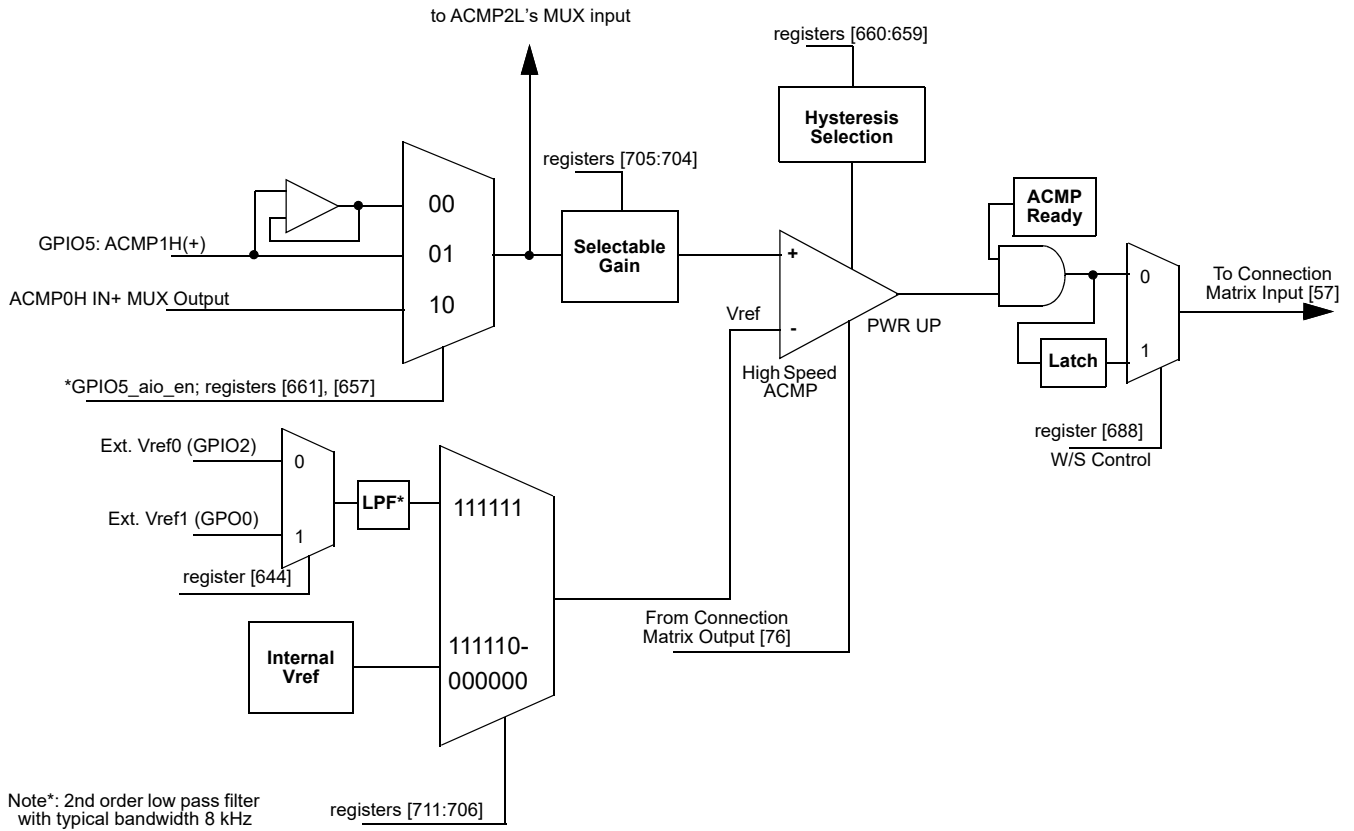

Figure 67: ACMP1H Block Diagram

SLG46855-A

Auto AEC-Q100 Qualified GreenPAK Programmable Mixed-Signal Matrix

9.3 ACMP2L BLOCK DIAGRAM

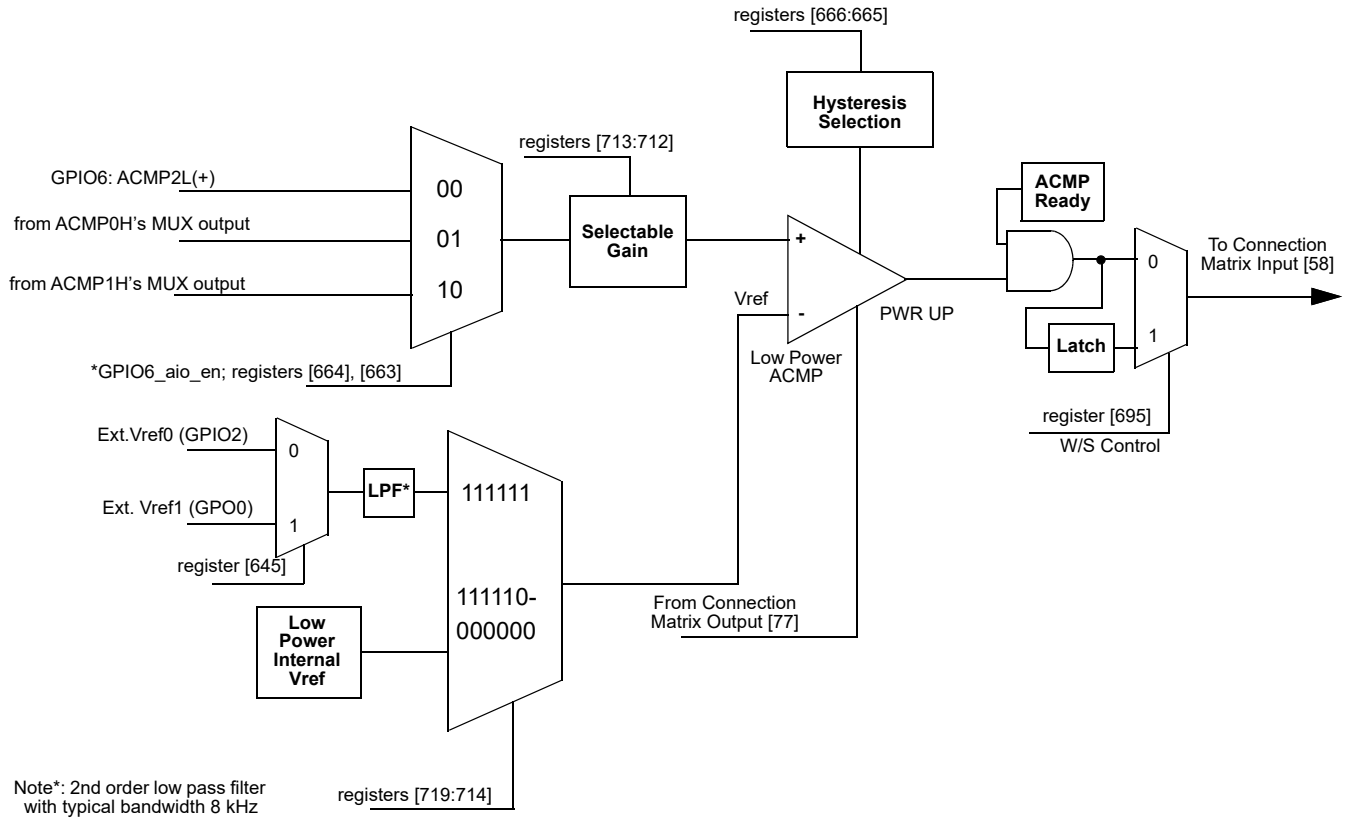

Figure 68: ACMP2L Block Diagram

SLG46855-A

Auto AEC-Q100 Qualified GreenPAK Programmable Mixed-Signal Matrix

9.4 ACMP3L BLOCK DIAGRAM

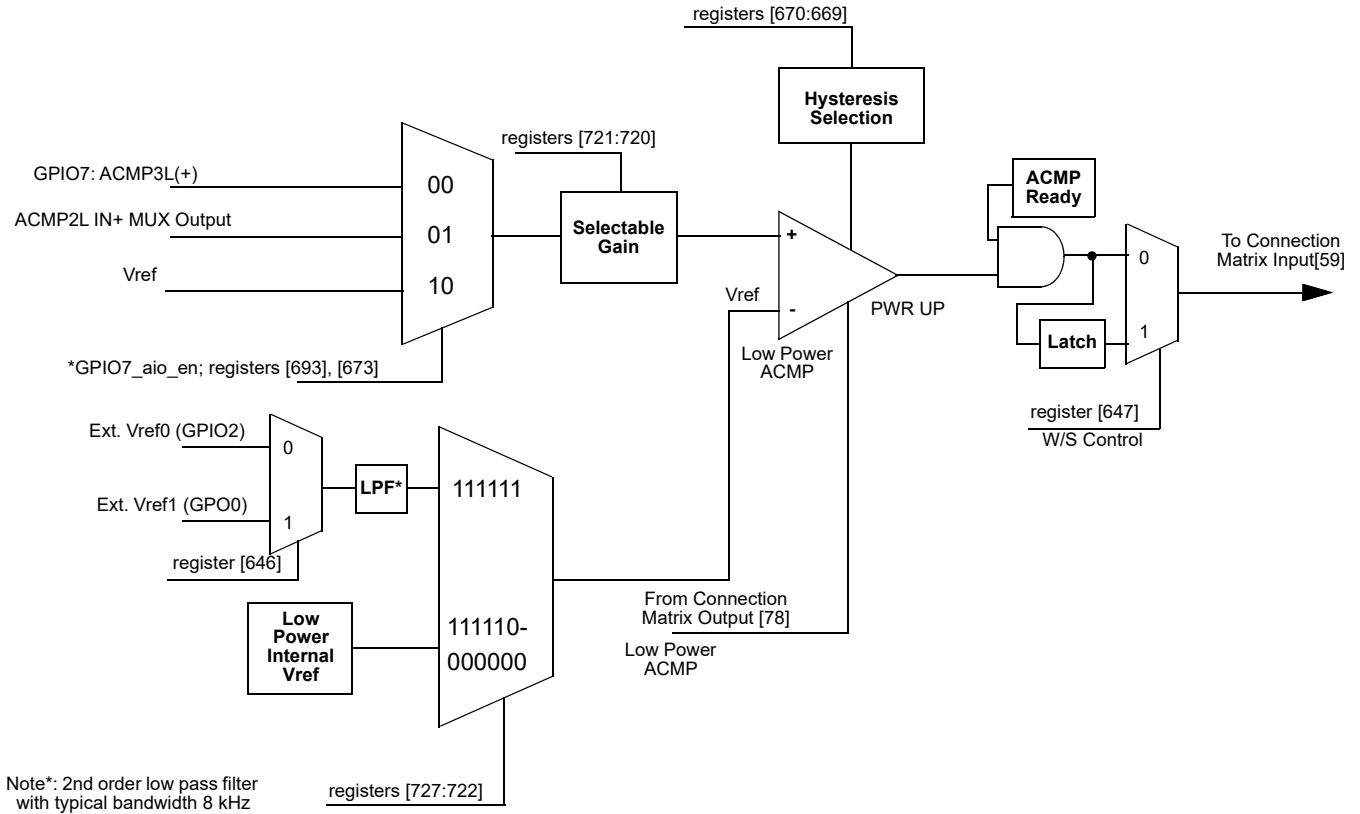

Figure 69: ACMP3L Block Diagram

SLG46855-A

Auto AEC-Q100 Qualified GreenPAK Programmable Mixed-Signal Matrix

9.5 ACMP TYPICAL PERFORMANCE

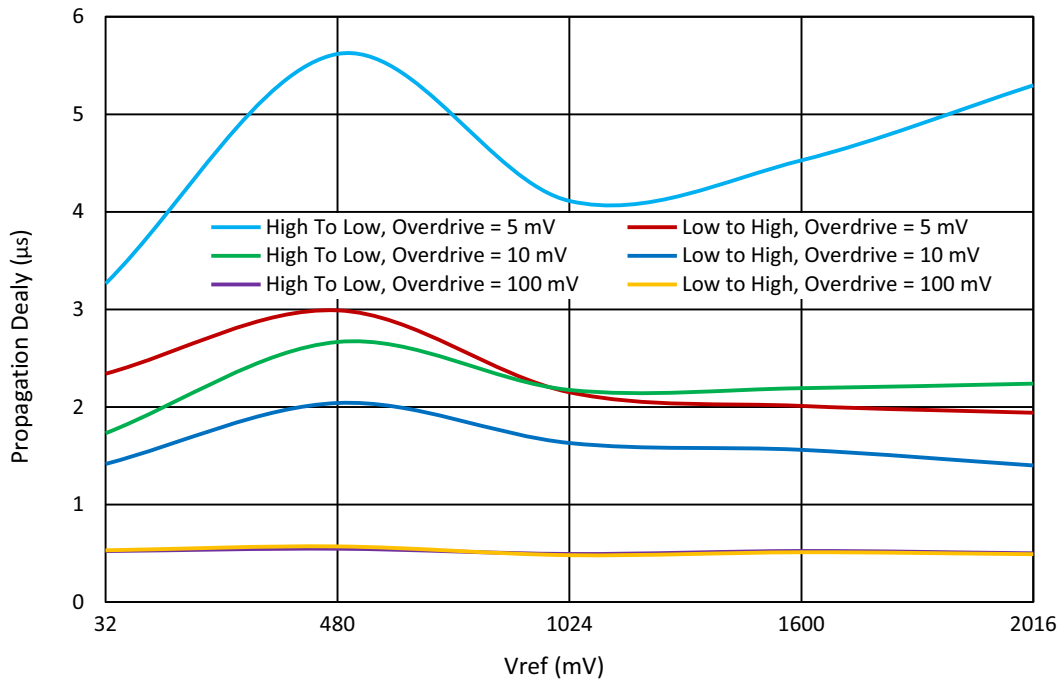

Figure 70: Typical Propagation Delay vs. Vref for ACMPxH at T = 25 °C, Gain = 1, Hysteresis = 0

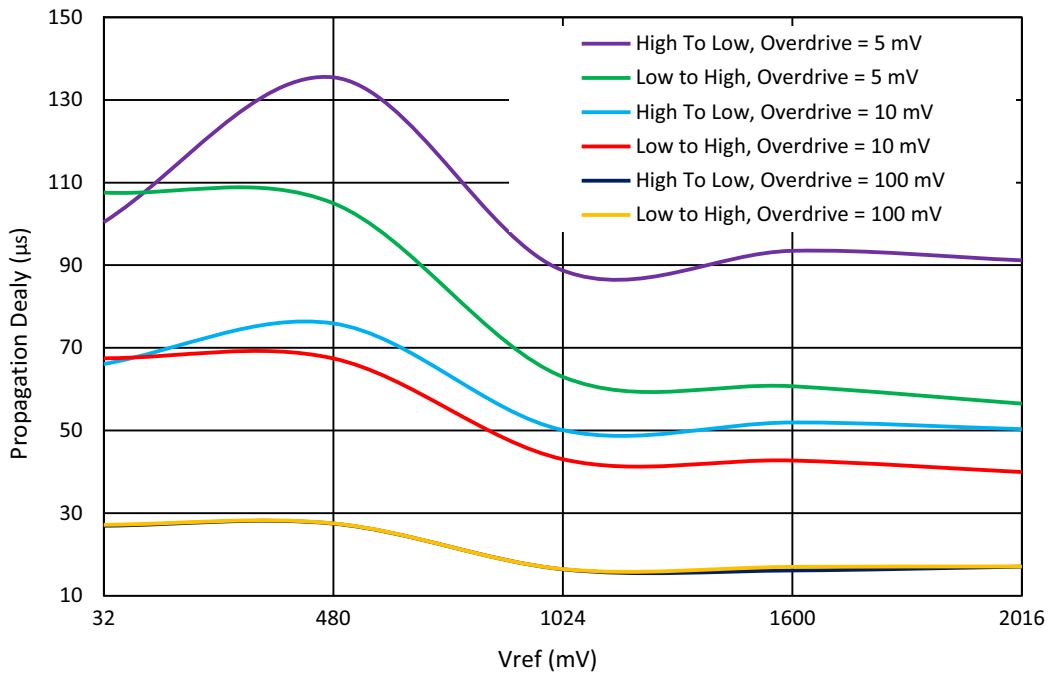

Figure 71: Typical Propagation Delay vs. Vref for ACMPxL at T = 25 °C, Gain = 1, Hysteresis = 0

SLG46855-A

Auto AEC-Q100 Qualified GreenPAK Programmable Mixed-Signal Matrix

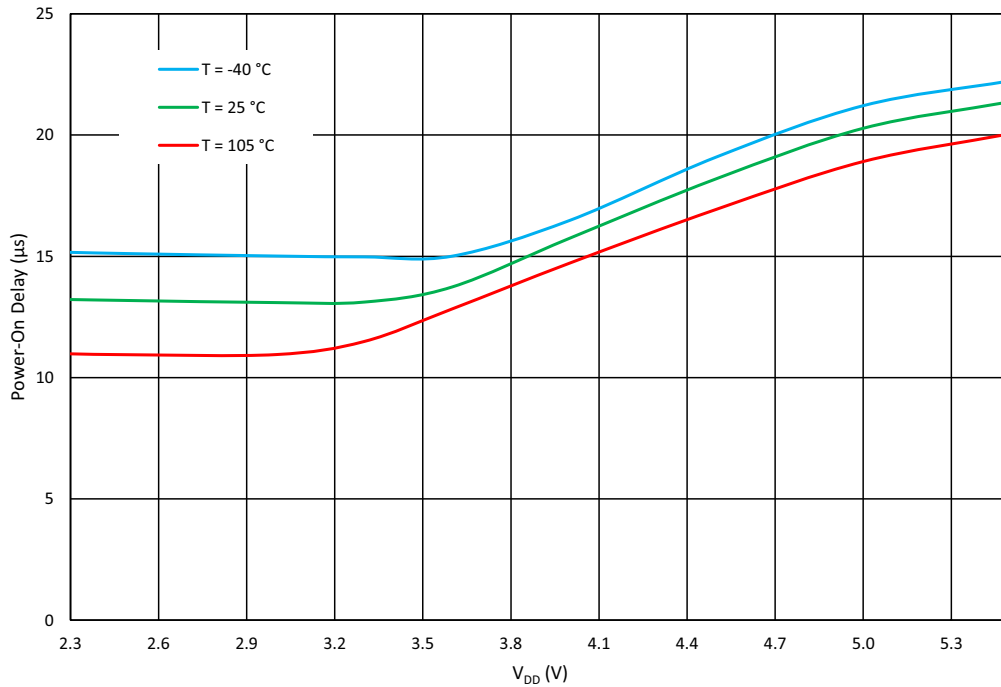

Figure 72: ACMPxH Power-On Delay vs. V<sub>DD</sub>

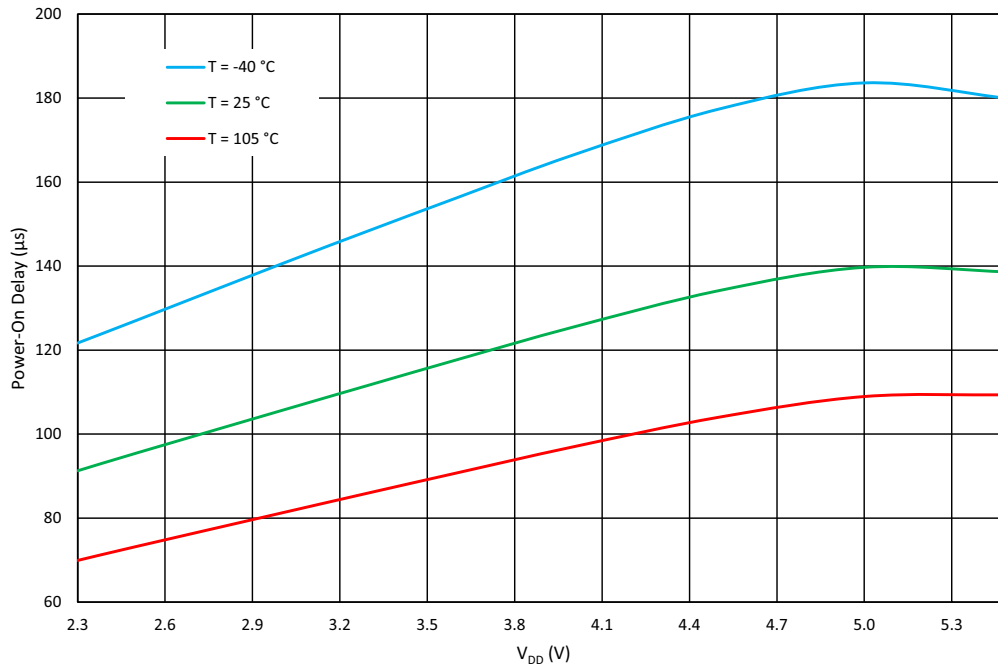

Figure 73: ACMPxL Power-On Delay vs. V<sub>DD</sub>

SLG46855-A

Auto AEC-Q100 Qualified GreenPAK Programmable Mixed-Signal Matrix

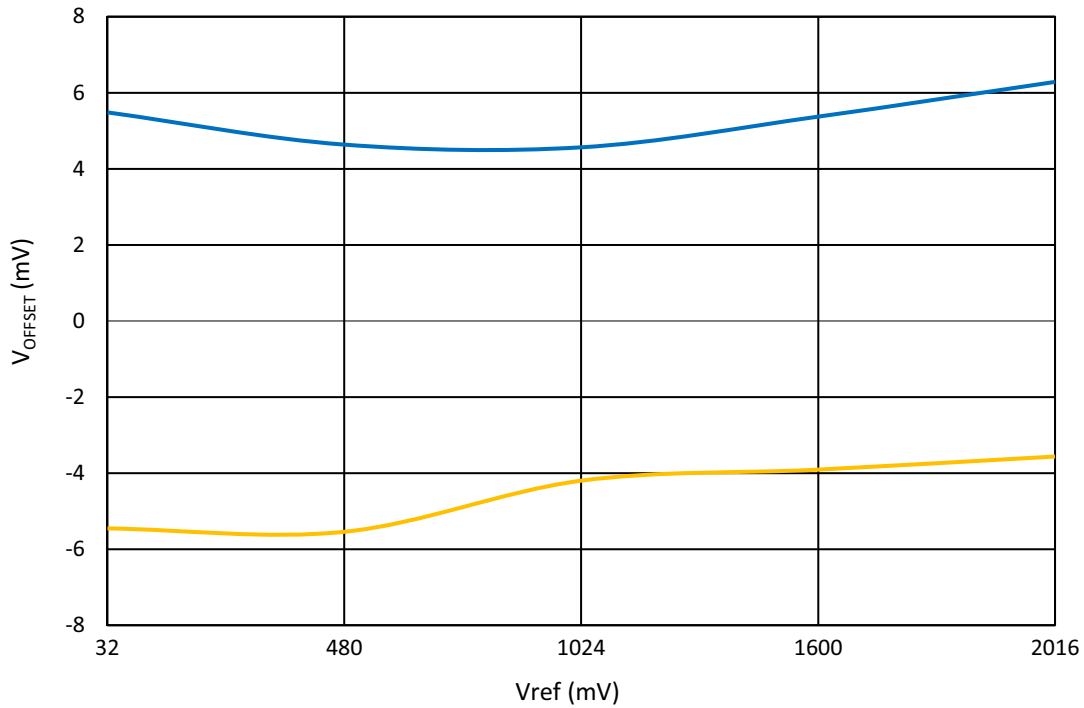

Figure 74: ACMPxH Input Offset Voltage vs. Vref at T = -40 °C to 105 °C

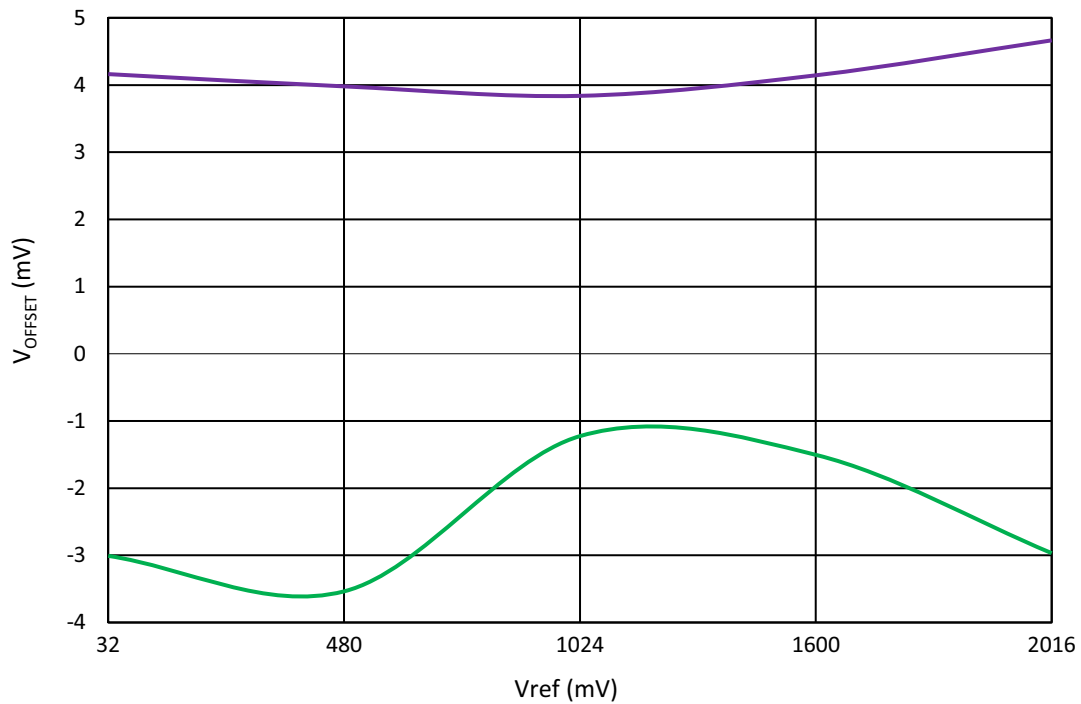

Figure 75: ACMPxL Input Offset Voltage vs. Vref at T = -40 °C to 105 °C



SLG46855-A

Auto AEC-Q100 Qualified GreenPAK Programmable Mixed-Signal Matrix

10 Programmable Delay/Edge Detector

The SLG46855-A has a programmable time delay logic cell that can generate a delay that is selectable from one of four timings (time2) configured in the GreenPAK Designer. The programmable time delay cell can generate one of four different delay patterns, rising edge detection, falling edge detection, both edge detection, and both edge delay. These four patterns can be further modified with the addition of delayed edge detection, which adds an extra unit of delay, as well as glitch rejection during the delay period. See Figure 76 for further information.

**Note:** The input signal must be longer than the delay, otherwise it will be filtered out.

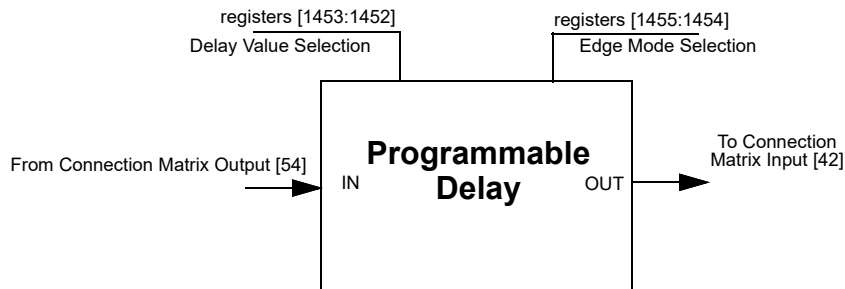

Figure 76: Programmable Delay

10.1 PROGRAMMABLE DELAY TIMING DIAGRAM - EDGE DETECTOR OUTPUT

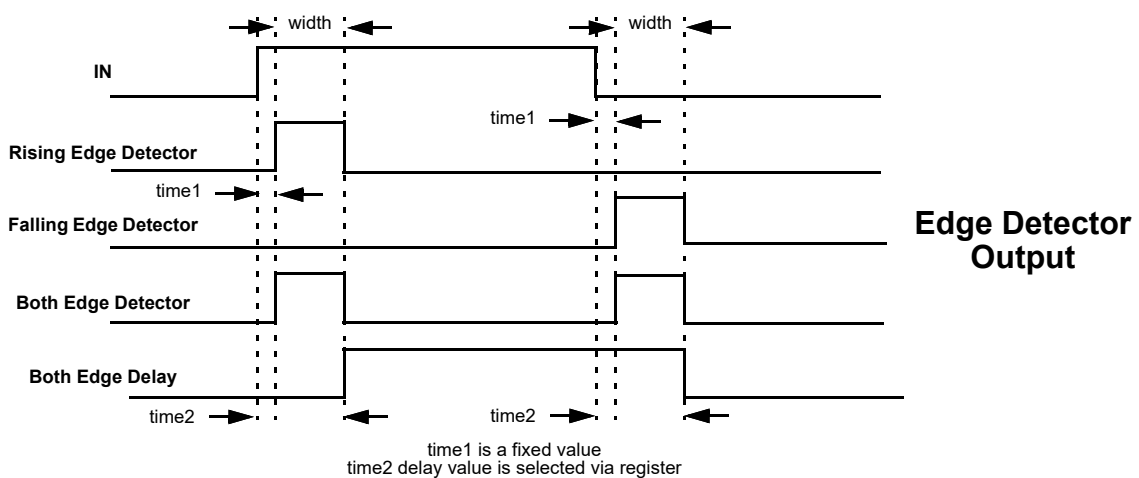

Figure 77: Edge Detector Output

Please refer to Table 12.

SLG46855-A

Auto AEC-Q100 Qualified GreenPAK Programmable Mixed-Signal Matrix

11 Additional Logic Function. Deglitch Filter

The SLG46855-A has one Deglitch Filter macrocell with inverter function that is connected directly to the Connection Matrix inputs and outputs. In addition, this macrocell can be configured as an Edge Detector, with the following settings:

- Rising Edge Detector
- Falling Edge Detector
- Both Edge Detector
- Both Edge Delay

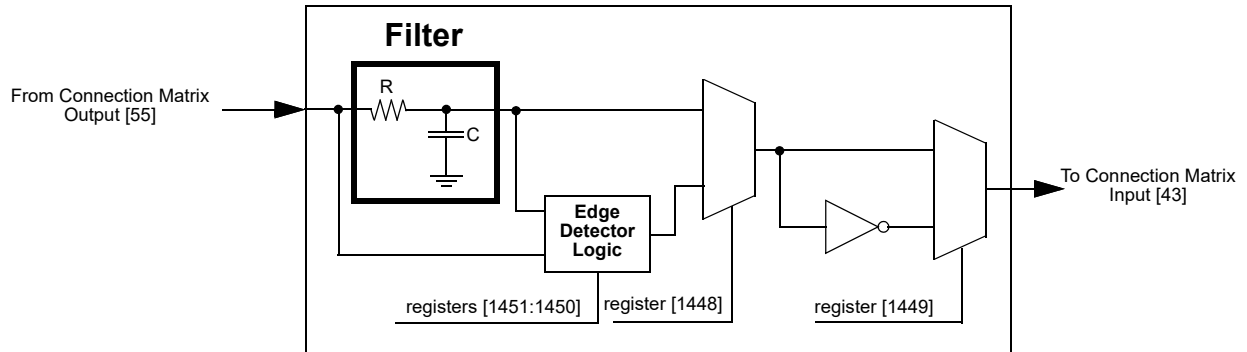

Figure 78: Deglitch Filter/Edge Detector

# SLG46855-A

## Auto AEC-Q100 Qualified GreenPAK Programmable Mixed-Signal Matrix

### 12 Voltage Reference

#### 12.1 VOLTAGE REFERENCE OVERVIEW

The SLG46855-A has a Voltage Reference (Vref) macrocell to provide references to the four analog comparators. This macrocell can supply a user selection of fixed voltage references, or temperature sensor output. The macrocell also has the option to output reference voltages on GPIO8 and GPIO9. See [Table 53](#) for the available selections for each analog comparator.

Also see [Figure 79](#), which shows the reference output structure.

#### 12.2 VREF SELECTION TABLE

**Table 54: Vref Selection Table**

SEL[5:0]	Vref	SEL[5:0]	Vref
0	0.032	32	1.056
1	0.064	33	1.088
2	0.096	34	1.12
3	0.128	35	1.152
4	0.16	36	1.184
5	0.192	37	1.216
6	0.224	38	1.248
7	0.256	39	1.28
8	0.288	40	1.312
9	0.32	41	1.344
10	0.352	42	1.376
11	0.384	43	1.408
12	0.416	44	1.44
13	0.448	45	1.472
14	0.48	46	1.504
15	0.512	47	1.536
16	0.544	48	1.568
17	0.576	49	1.6
18	0.608	50	1.632
19	0.64	51	1.664
20	0.672	52	1.696
21	0.704	53	1.728
22	0.736	54	1.76
23	0.768	55	1.792
24	0.8	56	1.824
25	0.832	57	1.856
26	0.864	58	1.888
27	0.896	59	1.92
28	0.928	60	1.952
29	0.96	61	1.984
30	0.992	62	2.016
31	1.024	63	External

SLG46855-A

Auto AEC-Q100 Qualified GreenPAK Programmable Mixed-Signal Matrix

12.3 VREF BLOCK DIAGRAM

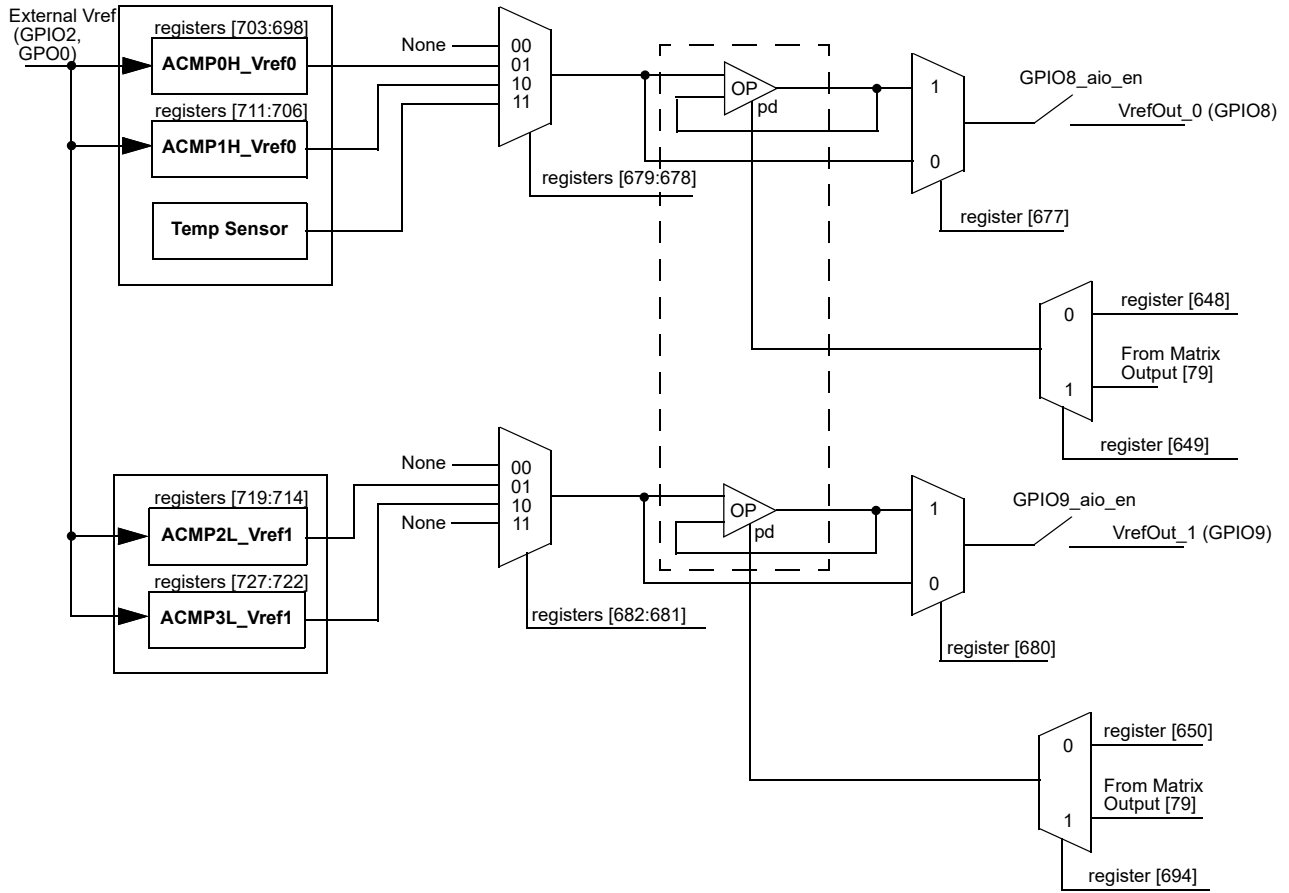

Figure 79: Voltage Reference Block Diagram

SLG46855-A

Auto AEC-Q100 Qualified GreenPAK Programmable Mixed-Signal Matrix

12.4 VREF LOAD REGULATION

**Note 1** It is not recommended to use Vref connected to external pin without buffer.

**Note 2** Vref buffer performance is not guaranteed at  $V_{DD} < 2.7$  V.

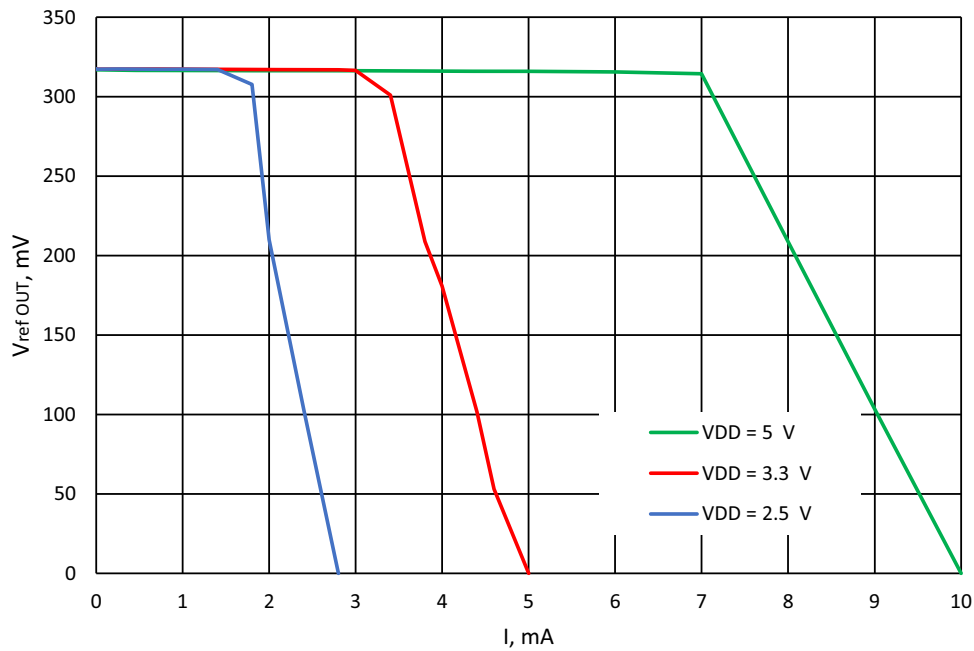

Figure 80: Typical Load Regulation, Vref = 320 mV, T = -40 °C to +105 °C, Buffer - Enabled

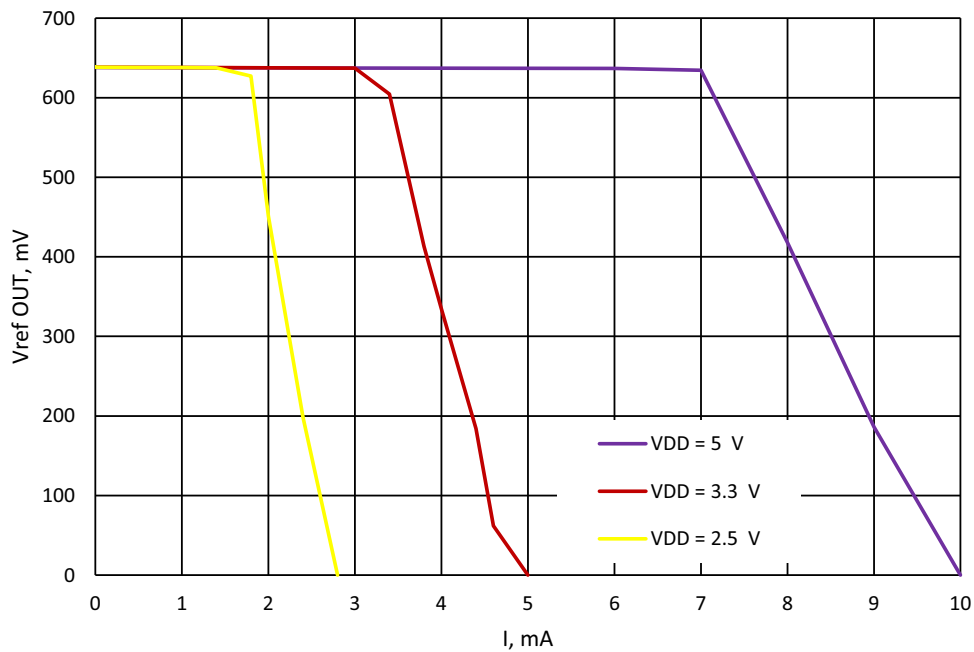

Figure 81: Typical Load Regulation, Vref = 640 mV, T = -40 °C to +105 °C, Buffer - Enabled

SLG46855-A

Auto AEC-Q100 Qualified GreenPAK Programmable Mixed-Signal Matrix

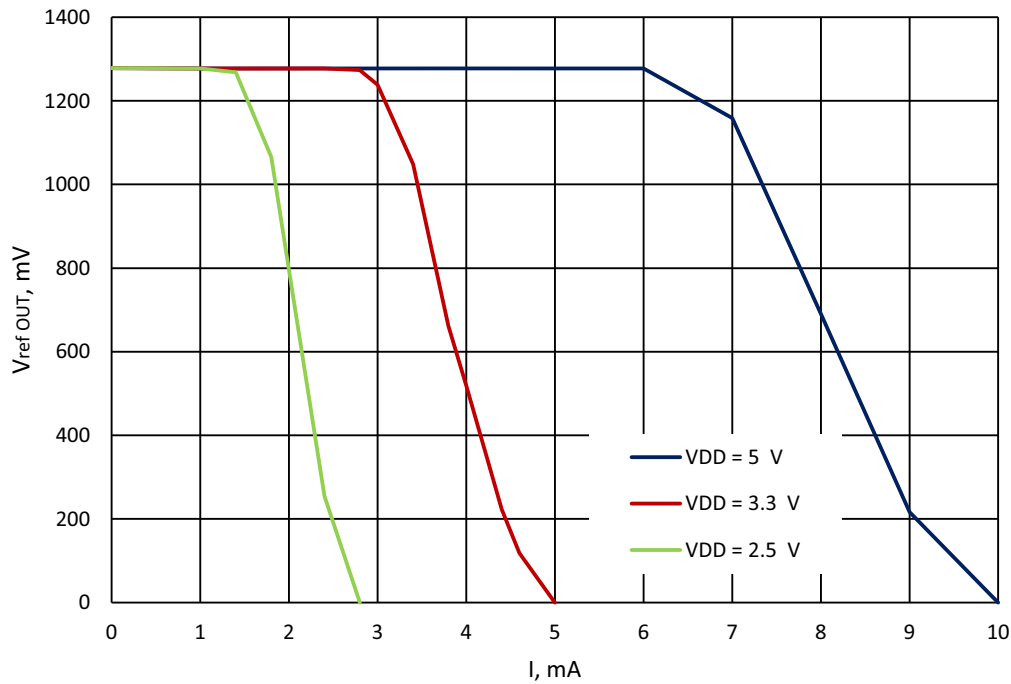

Figure 82: Typical Load Regulation, Vref = 1280 mV, T = -40 °C to +105 °C, Buffer - Enabled

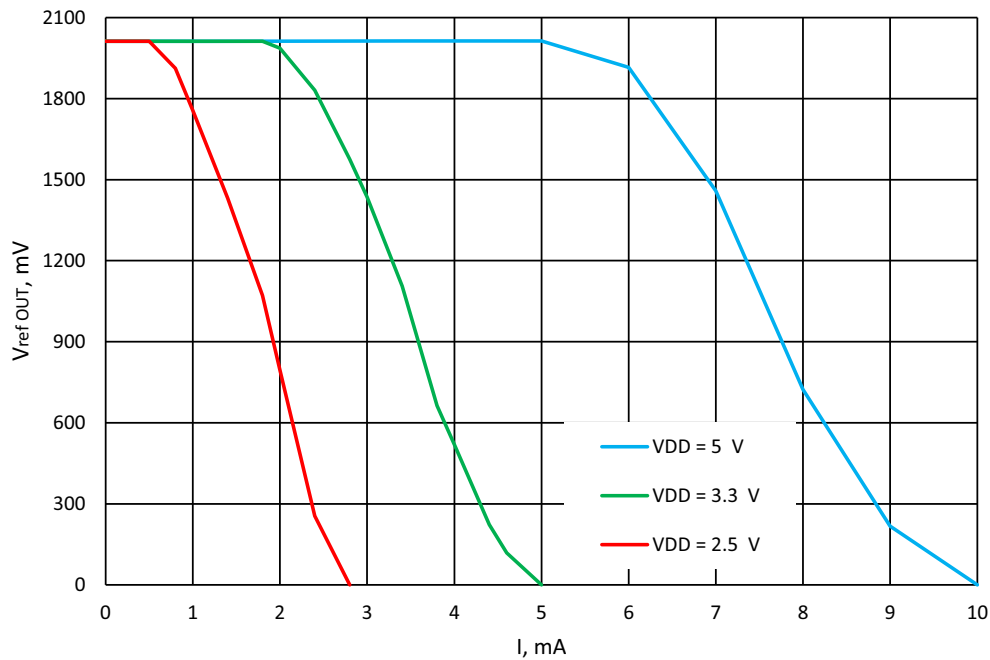

Figure 83: Typical Load Regulation, Vref = 2016 mV, T = -40 °C to +105 °C, Buffer - Enabled

# SLG46855-A

## Auto AEC-Q100 Qualified GreenPAK Programmable Mixed-Signal Matrix

### 13 Clocking

#### 13.1 OSC GENERAL DESCRIPTION

The SLG46855-A has three internal oscillators to support a variety of applications:

- Oscillator0 (2.048 kHz)
- Oscillator1 (2.048 MHz)
- Oscillator2 (25 MHz).

There are two divider stages for each oscillator that gives the user flexibility for introducing clock signals to connection matrix, as well as various other macrocells. The pre-divider (first stage) for Oscillator allows the selection of /1, /2, /4 or /8 to divide down frequency from the fundamental. The second stage divider has an input of frequency from the pre-divider, and outputs one of eight different frequencies divided by /1, /2, /3, /4, /8, /12, /24 or /64 on Connection Matrix Input lines [53], [54], and [55]. Please see [Figure 87](#) for more details on the SLG46855-A clock scheme.

Oscillator2 (25 MHz) has an additional function of 100 ns delayed startup, which can be enabled/disabled by register [749]. This function is recommended to use when analog blocks are used along with the Oscillator.

The Matrix Power-down/Force On function allows switching off or force on the oscillator using an external pin. The Matrix Power-down/Force On (Connection Matrix Output [80], [81], [82]) signal has the highest priority. The OSC operates according to the following table:

**Table 55: Oscillator Operation Mode Configuration Settings**

POR	External Clock Selection	Signal From Connection Matrix	Register: Power-Down or Force On by Matrix Input	Register: Auto Power-On or Force On	OSC Enable Signal from CNT/DLY Macrocells	OSC Operation Mode
0	X	X	X	X	X	OFF
1	1	X	X	X	X	Internal OSC is OFF, logic is ON
1	0	1	0	X	X	OFF
1	0	1	1	X	X	ON
1	0	0	X	1	X	ON
1	0	0	X	0	CNT/DLY requires OSC	ON
1	0	0	X	0	CNT/DLY does not require OSC	OFF

**Note 1** The OSC will run only when any macrocell that uses OSC is powered on.

SLG46855-A

Auto AEC-Q100 Qualified GreenPAK Programmable Mixed-Signal Matrix

13.2 OSCILLATOR0 (2.048 KHZ)

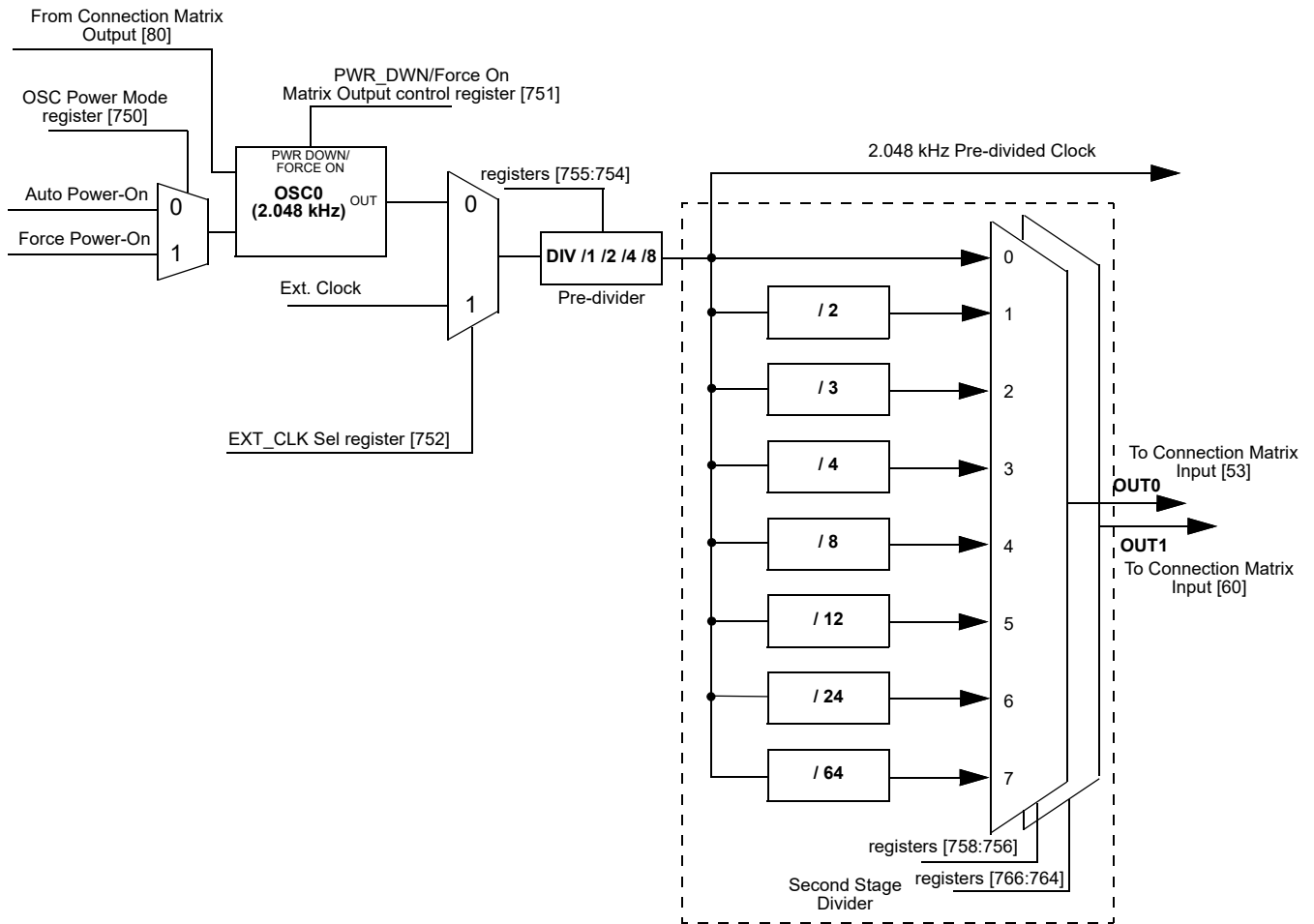

Figure 84: Oscillator0 Block Diagram



SLG46855-A

Auto AEC-Q100 Qualified GreenPAK Programmable Mixed-Signal Matrix

13.3 OSCILLATOR1 (2.048 MHZ)

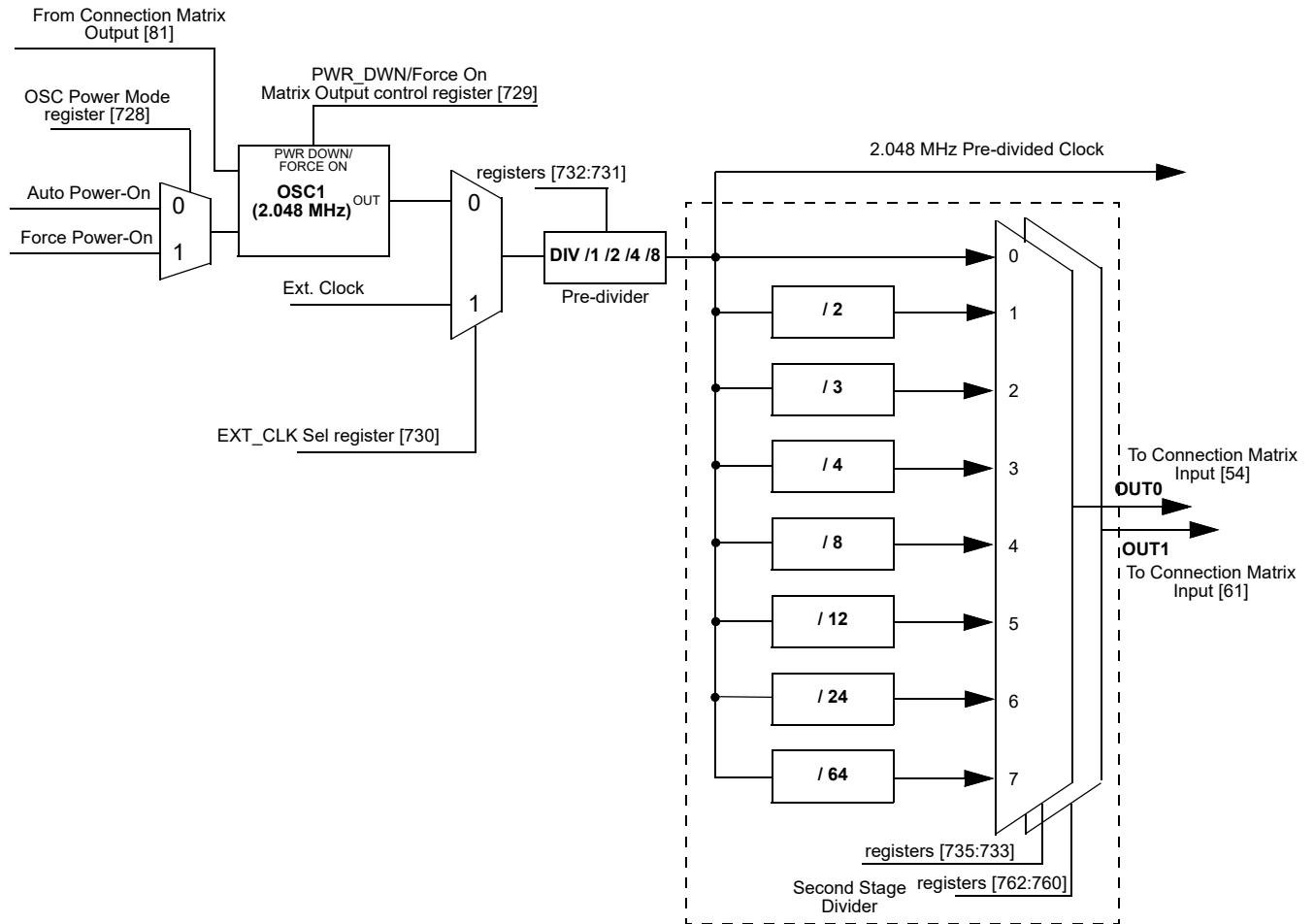

Figure 85: Oscillator1 Block Diagram

SLG46855-A

Auto AEC-Q100 Qualified GreenPAK Programmable Mixed-Signal Matrix

13.4 OSCILLATOR2 (25 MHZ)

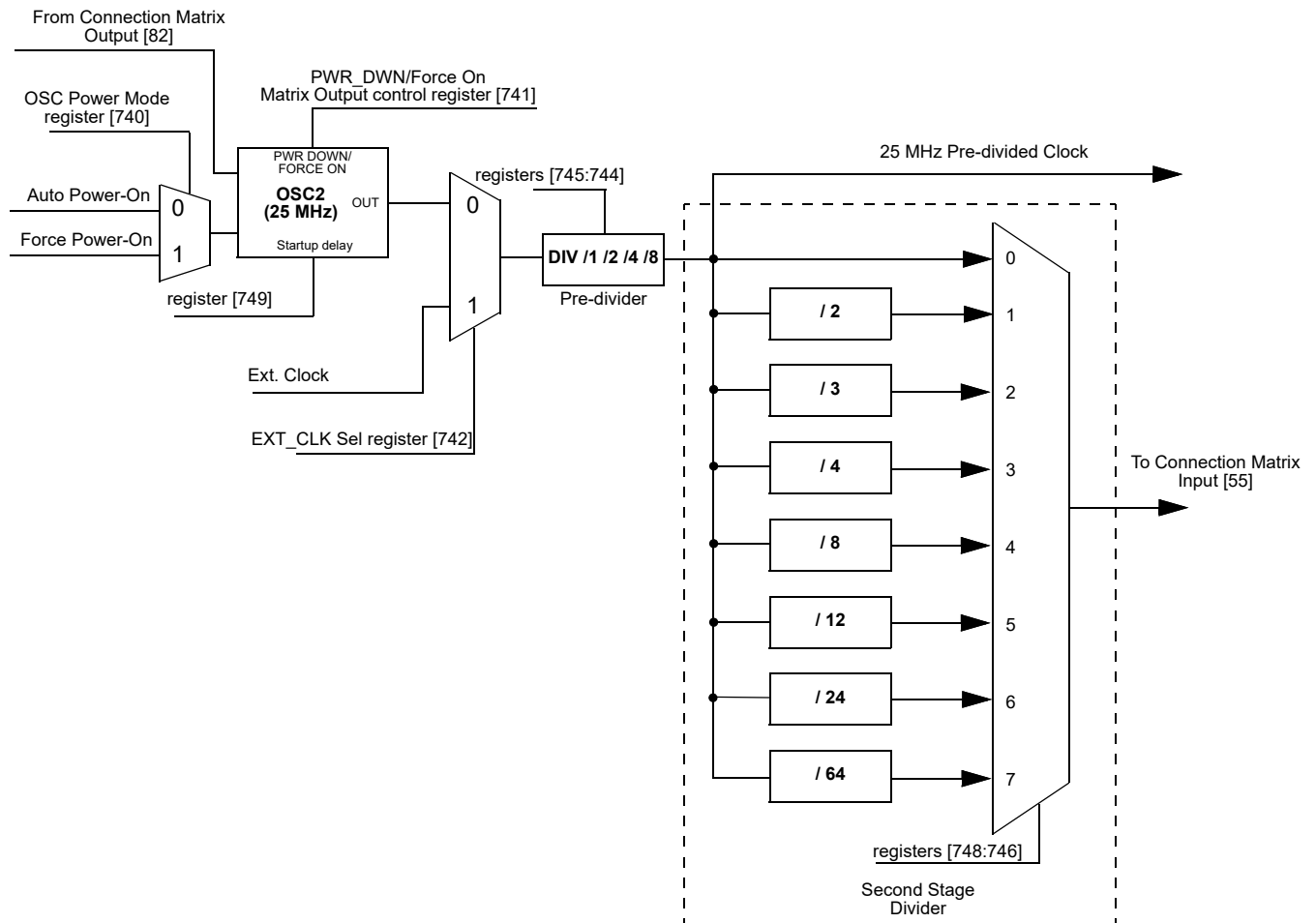

Figure 86: Oscillator2 Block Diagram

13.5 CNT/DLY CLOCK SCHEME

Each CNT/DLY within Multi-Function macrocell has its own additional clock divider connected to oscillators pre-divider. Available dividers are:

- OSC0/1, OSC0/8, OSC0/64, OSC0/512, OSC0/4096, OSC0/32768, OSC0/262144
- OSC1/1, OSC1/8, OSC1/64, OSC1/512
- OSC2/1, OSC2/4

SLG46855-A

Auto AEC-Q100 Qualified GreenPAK Programmable Mixed-Signal Matrix

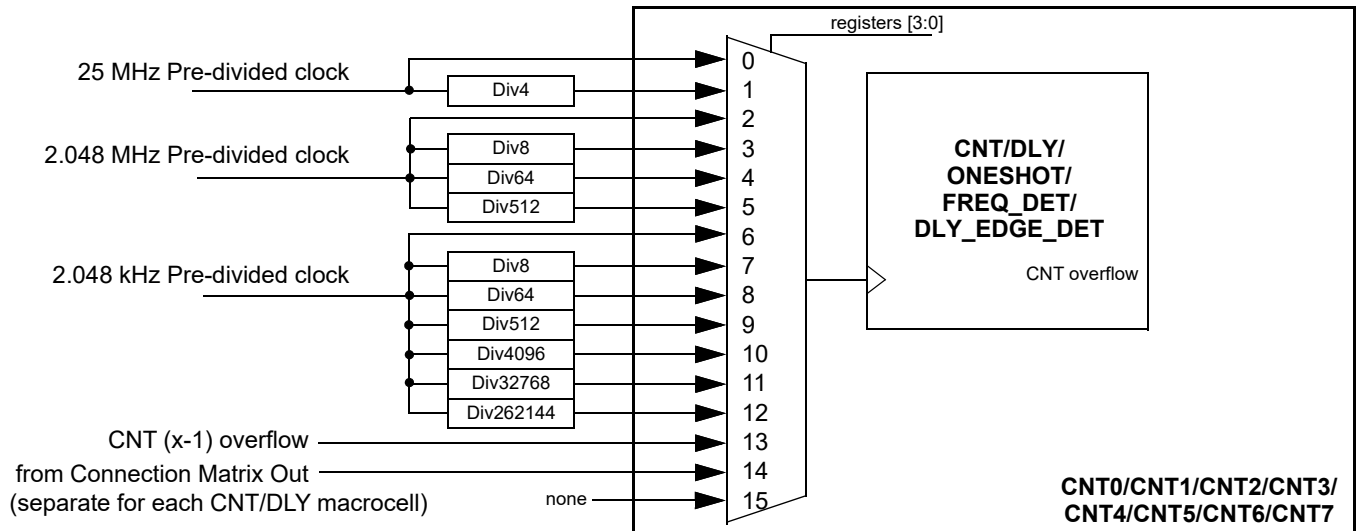

Figure 87: Clock Scheme

13.6 EXTERNAL CLOCKING

The SLG46855-A supports several ways to use an external, higher accuracy clock as a reference source for internal operations.

13.6.1 GPIO Source for Oscillator0 (2.048 kHz)

When register [752] is set to 1, an external clocking signal on GPIO will be routed in place of the internal oscillator derived 2.048 kHz clock source. See Figure 84. The low and high limits for external frequency that can be selected are 0 MHz and 10 MHz.

13.6.2 GPIO2 Source for Oscillator1 (2.048 MHz)

When register [730] is set to 1, an external clocking signal on GPIO2 will be routed in place of the internal oscillator derived 2.048 MHz clock source. See Figure 85. The low and high limits for external frequency that can be selected are 0 MHz and 10 MHz.

13.6.3 GPIO8 Source for Oscillator 2 (25 MHz)

When register [742] is set to 1, an external clocking signal on GPIO8 will be routed in place of the internal oscillator derived 25 MHz clock source. See Figure 86. The external frequency range is 0 MHz to 20 MHz at  $V_{DD} = 2.3\text{ V}$ , 30 MHz at  $V_{DD} = 3.3\text{ V}$ , 50 MHz at  $V_{DD} = 5.0\text{ V}$ . When an external clock is selected for OSC2, the oscillator's output signal will be inverted with respect to the GPIO8 input signal.

SLG46855-A

Auto AEC-Q100 Qualified GreenPAK Programmable Mixed-Signal Matrix

13.7 OSCILLATORS POWER-ON DELAY

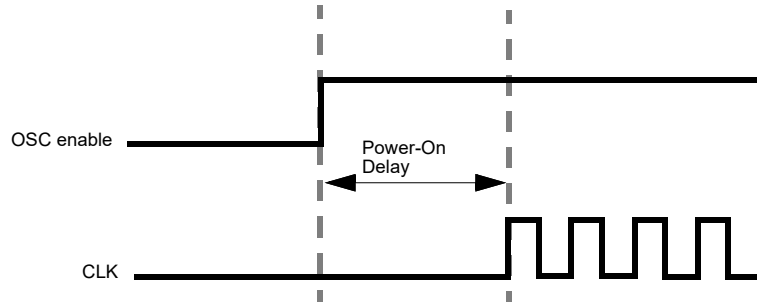

Figure 88: Oscillator Startup Diagram

**Note 1** OSC power mode: “Auto Power-On”.

**Note 2** “OSC enable” signal appears when any macrocell that uses OSC is powered on.

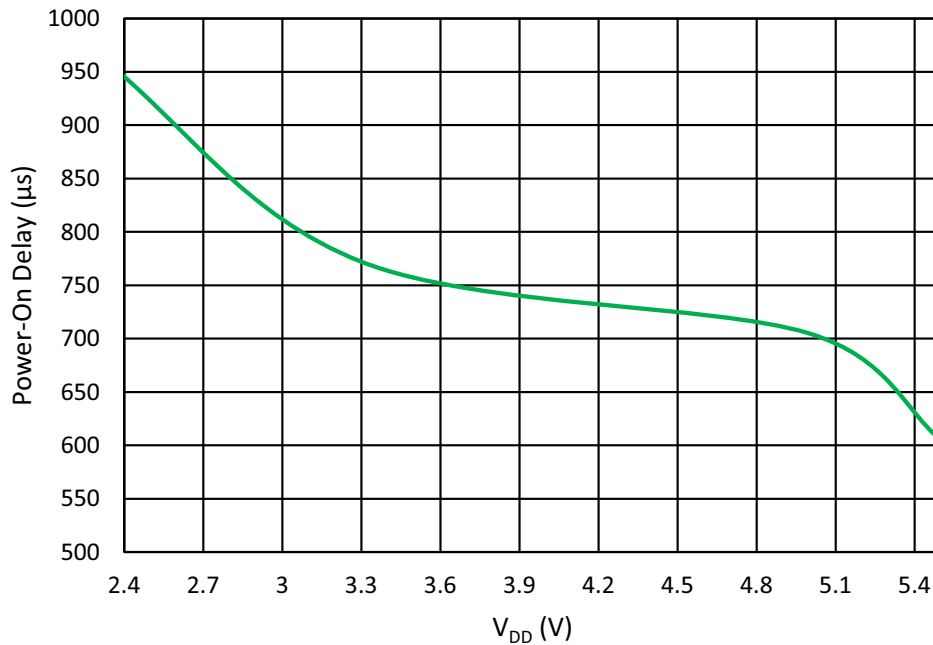

Figure 89: Oscillator0 Maximum Power-On Delay vs. V<sub>DD</sub> at T = 25 °C, OSC0 = 2.048 kHz

SLG46855-A

Auto AEC-Q100 Qualified GreenPAK Programmable Mixed-Signal Matrix

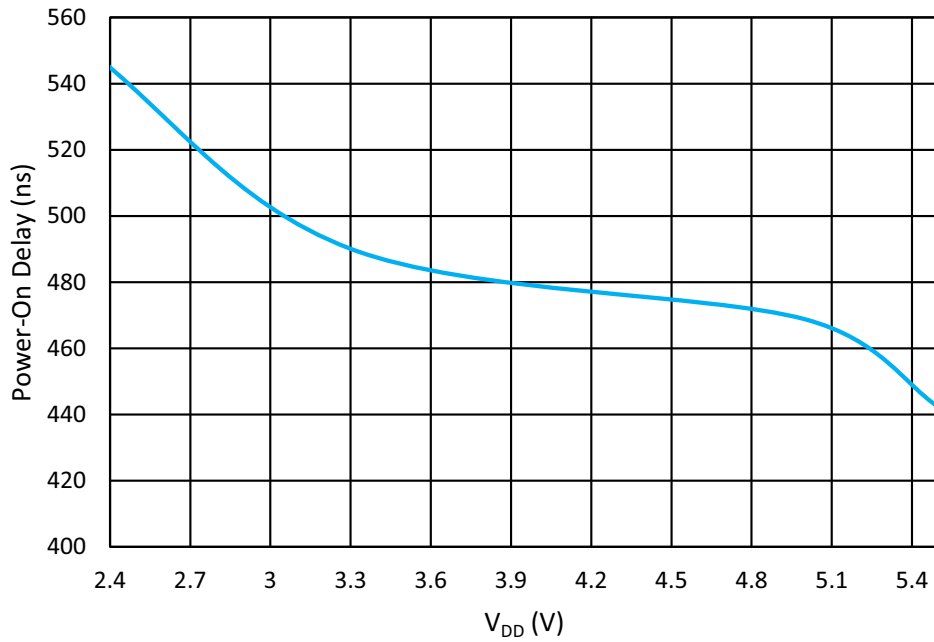

Figure 90: Oscillator1 Maximum Power-On Delay vs. V<sub>DD</sub> at T = 25 °C, OSC1 = 2.048 MHz

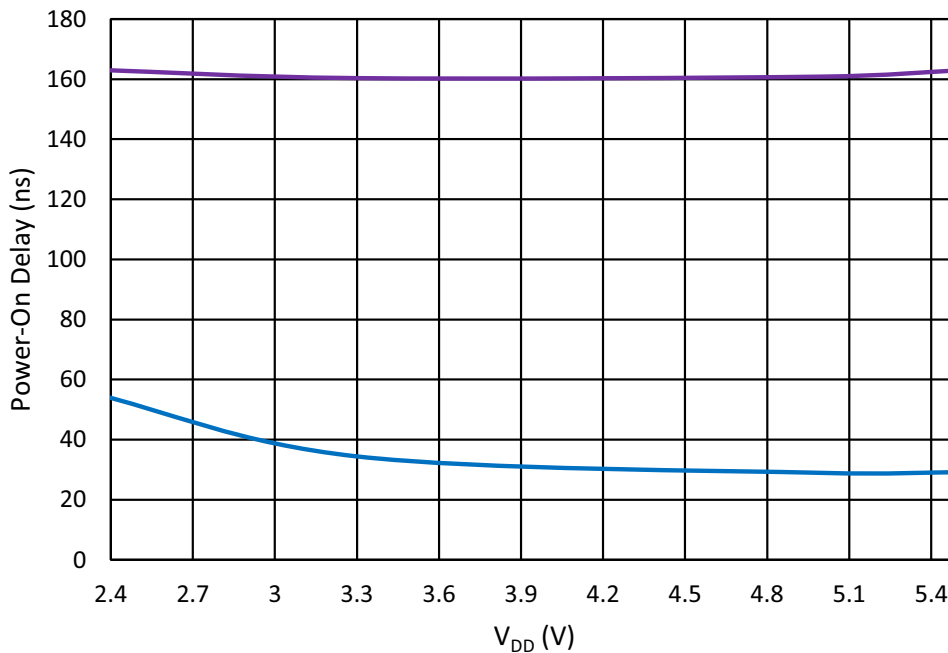

Figure 91: Oscillator2 Maximum Power-On Delay vs. V<sub>DD</sub> at T = 25 °C, OSC2 = 25 MHz

SLG46855-A

Auto AEC-Q100 Qualified GreenPAK Programmable Mixed-Signal Matrix

13.8 OSCILLATORS ACCURACY

Note: OSC power setting: Force Power-On; Clock to matrix input - enable; Bandgap: turn on by register - enable.

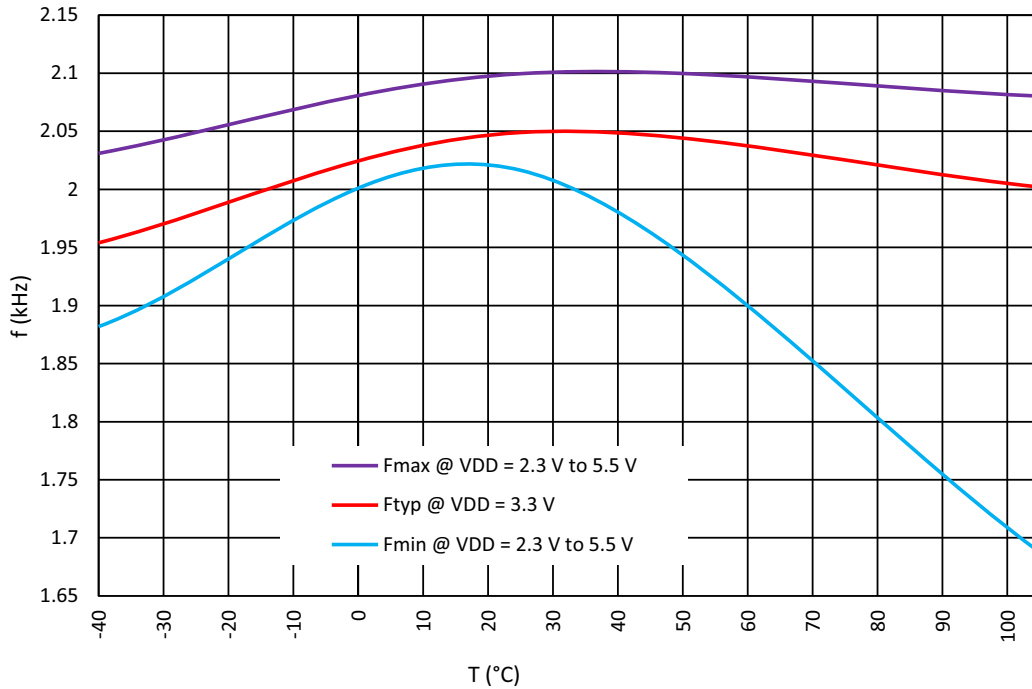

Figure 92: Oscillator0 Frequency vs. Temperature, OSC0 = 2.048 kHz

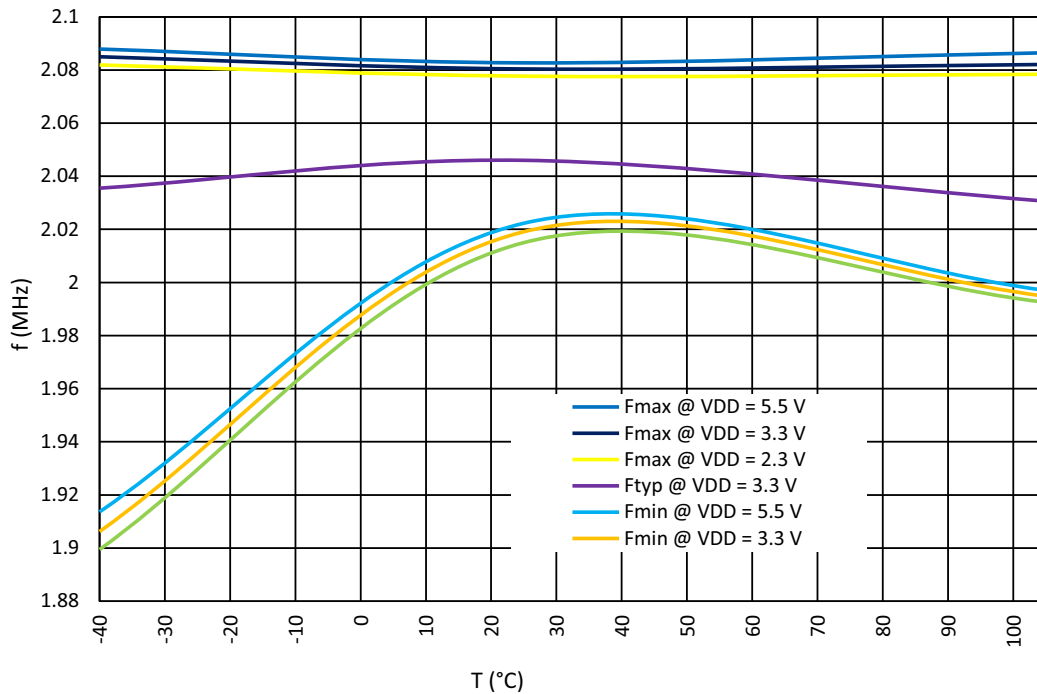

Figure 93: Oscillator1 Frequency vs. Temperature, OSC1 = 2.048 MHz

SLG46855-A

Auto AEC-Q100 Qualified GreenPAK Programmable Mixed-Signal Matrix

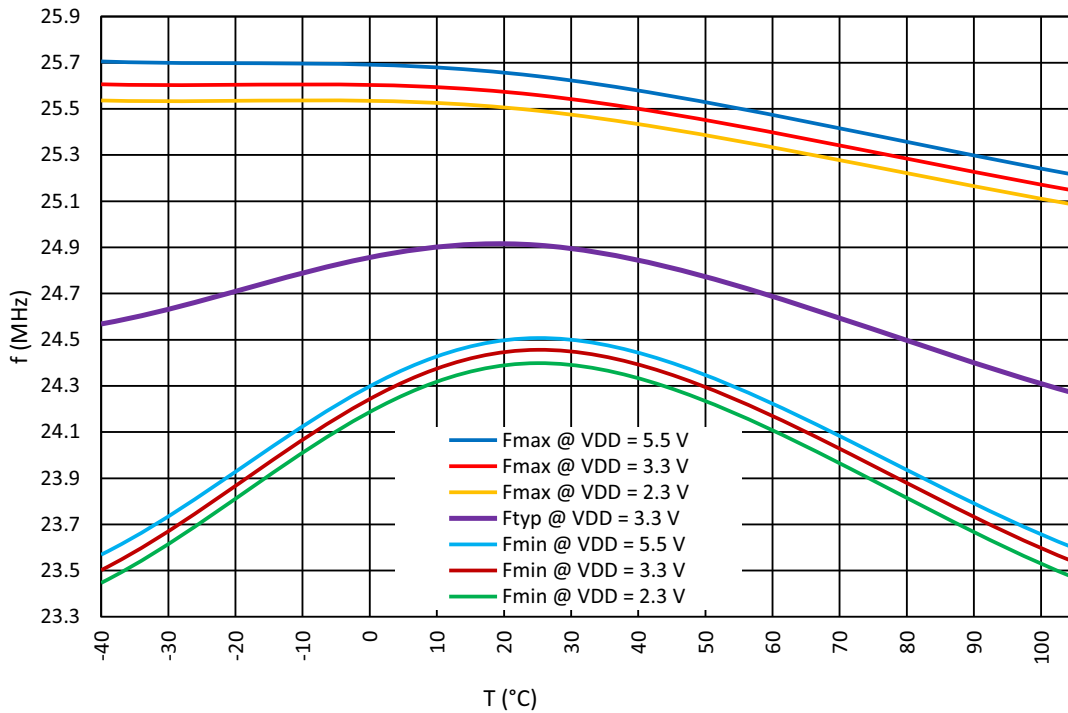

Figure 94: Oscillator2 Frequency vs. Temperature, OSC2 = 25 MHz

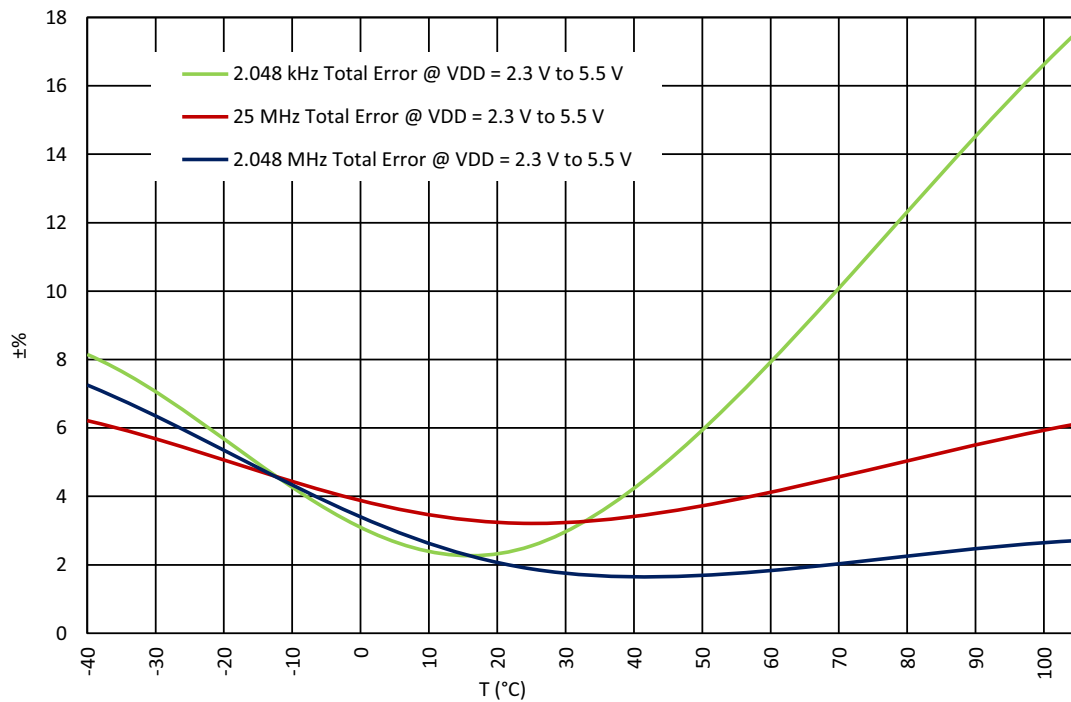

Figure 95: Oscillators Total Error vs. Temperature

Note: For more information see Section 3.9.

### 14 Power-On Reset

The SLG46855-A has a Power-On Reset (POR) macrocell to ensure correct device initialization and operation of all macrocells in the device. The purpose of the POR circuit is to have consistent behavior and predictable results when the  $V_{DD}$  power is first ramping to the device, and also while the  $V_{DD}$  is falling during Power-down. To accomplish this goal, the POR drives a defined sequence of internal events that trigger changes to the states of different macrocells inside the device, and finally to the state of the IOs.

#### 14.1 GENERAL OPERATION

The SLG46855-A is guaranteed to be powered down and non-operational when the  $V_{DD}$  voltage (voltage on PIN1) is less than Power-Off Threshold (see in [Table 6](#)), but not less than -0.6 V. Another essential condition for the chip to be powered down is that no voltage higher (Note) than the  $V_{DD}$  voltage is applied to any other PIN. For example, if  $V_{DD}$  voltage is 0.3 V, applying a voltage higher than 0.3 V to any other PIN is incorrect, and can lead to incorrect or unexpected device behavior.

**Note:** There is a 0.6 V margin due to forward drop voltage of the ESD protection diodes.

To start the POR sequence in the SLG46855-A, the voltage applied on the  $V_{DD}$  should be higher than the Power-On threshold (Note). The full operational  $V_{DD}$  range for the SLG46855-A is 2.3 V to 5.5 V. This means that the  $V_{DD}$  voltage must ramp up to the operational voltage value, but the POR sequence will start earlier, as soon as the  $V_{DD}$  voltage rises to the Power-On threshold. After the POR sequence has started, the SLG46855-A will have a typical period of time to go through all the steps in the sequence (noted in the datasheet for that device), and will be ready and completely operational after the POR sequence is complete.

**Note:** The Power-On threshold is defined in [Table 6](#).

To power down the chip the  $V_{DD}$  voltage should be lower than the operational and to guarantee that chip is powered down it should be less than Power-Off Threshold.

All PINs are in high impedance state when the chip is powered down and while the POR sequence is taking place. The last step in the POR sequence releases the IO structures from the high impedance state, at which time the device is operational. The pin configuration at this point in time is defined by the design programmed into the chip. Also, as it was mentioned before the voltage on PINs can't be bigger than the  $V_{DD}$ , this rule also applies to the case when the chip is powered on.



# SLG46855-A

## Auto AEC-Q100 Qualified GreenPAK Programmable Mixed-Signal Matrix

### 14.2 POR SEQUENCE

The POR system generates a sequence of signals that enable certain macrocells. The sequence is shown in [Figure 96](#).

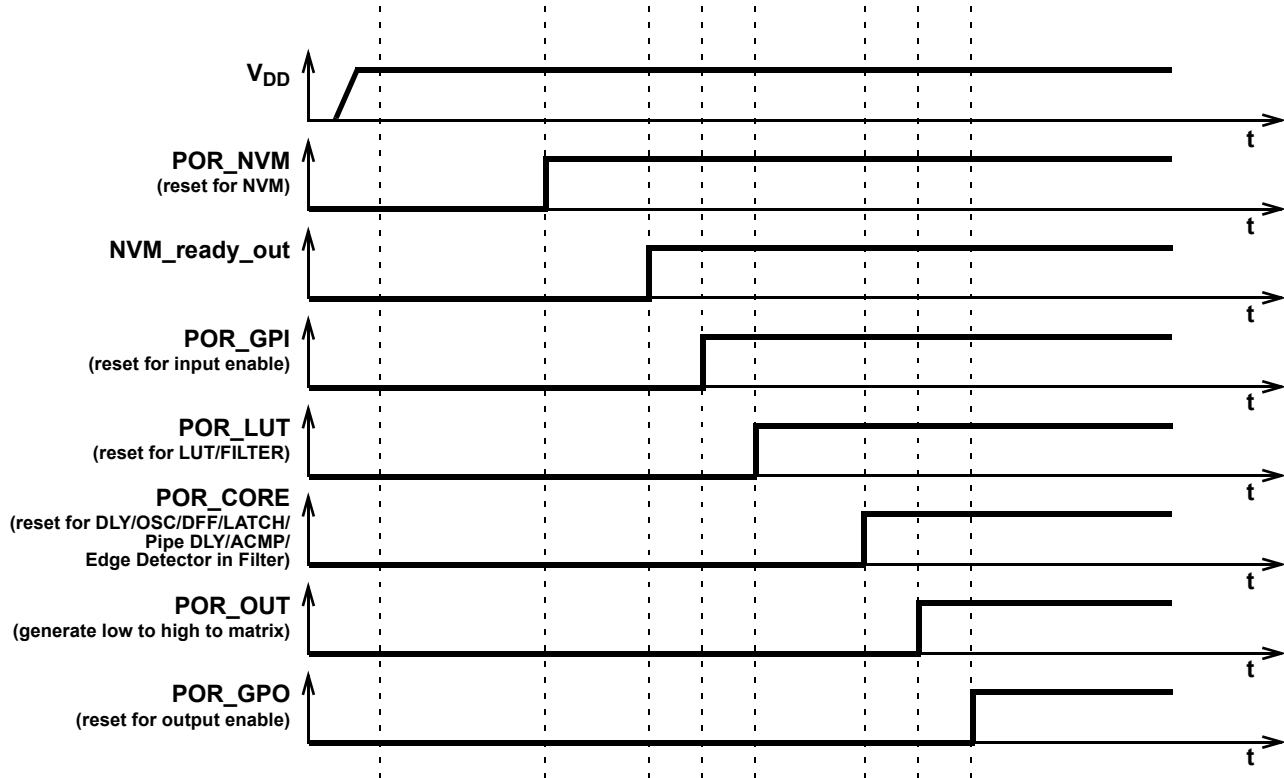

Figure 96: POR Sequence

As can be seen from [Figure 96](#) after the  $V_{DD}$  has start ramping up and crosses the Power-On threshold, first, the on-chip NVM memory is reset. Next, the chip reads the data from NVM, and transfers this information to a CMOS LATCH that serves to configure each macrocell, and the Connection Matrix which routes signals between macrocells. The third stage causes the reset of the input pins, and then to enable them. After that, the LUTs are reset and become active. After LUTs the Delay cells, OSCs, DFFs, LATCHES, and Pipe Delay are initialized. Only after all macrocells are initialized internal POR signal (POR macrocell output) goes from LOW to HIGH. The last portion of the device to be initialized are the output pins, which transition from high impedance to active at this point.

The typical time that takes to complete the POR sequence varies by device type in the GreenPAK family. It also depends on many environmental factors, such as: slew rate,  $V_{DD}$  value, temperature, and even will vary from chip to chip (process influence).

### 14.3 MACROCELLS OUTPUT STATES DURING POR SEQUENCE

To have a full picture of SLG46855-A operation during powering and POR sequence, review the overview the macrocell output states during the POR sequence ([Figure 97](#) describes the output signals states).

First, before the NVM has been reset, all macrocells have their output set to logic LOW (except the output pins which are in high impedance state). On the next step, some of the macrocells start initialization: input pins output state becomes LOW; LUTs also output LOW. Only P\_DLY macrocell configured as edge detector becomes active at this time. After that input pins are enabled.

# SLG46855-A

## Auto AEC-Q100 Qualified GreenPAK Programmable Mixed-Signal Matrix

Next, only LUTs are configured. Next, all other macrocells are initialized. After macrocells are initialized, internal POR matrix signal switches from LOW to HIGH. The last are output pins that become active and determined by the input signals.

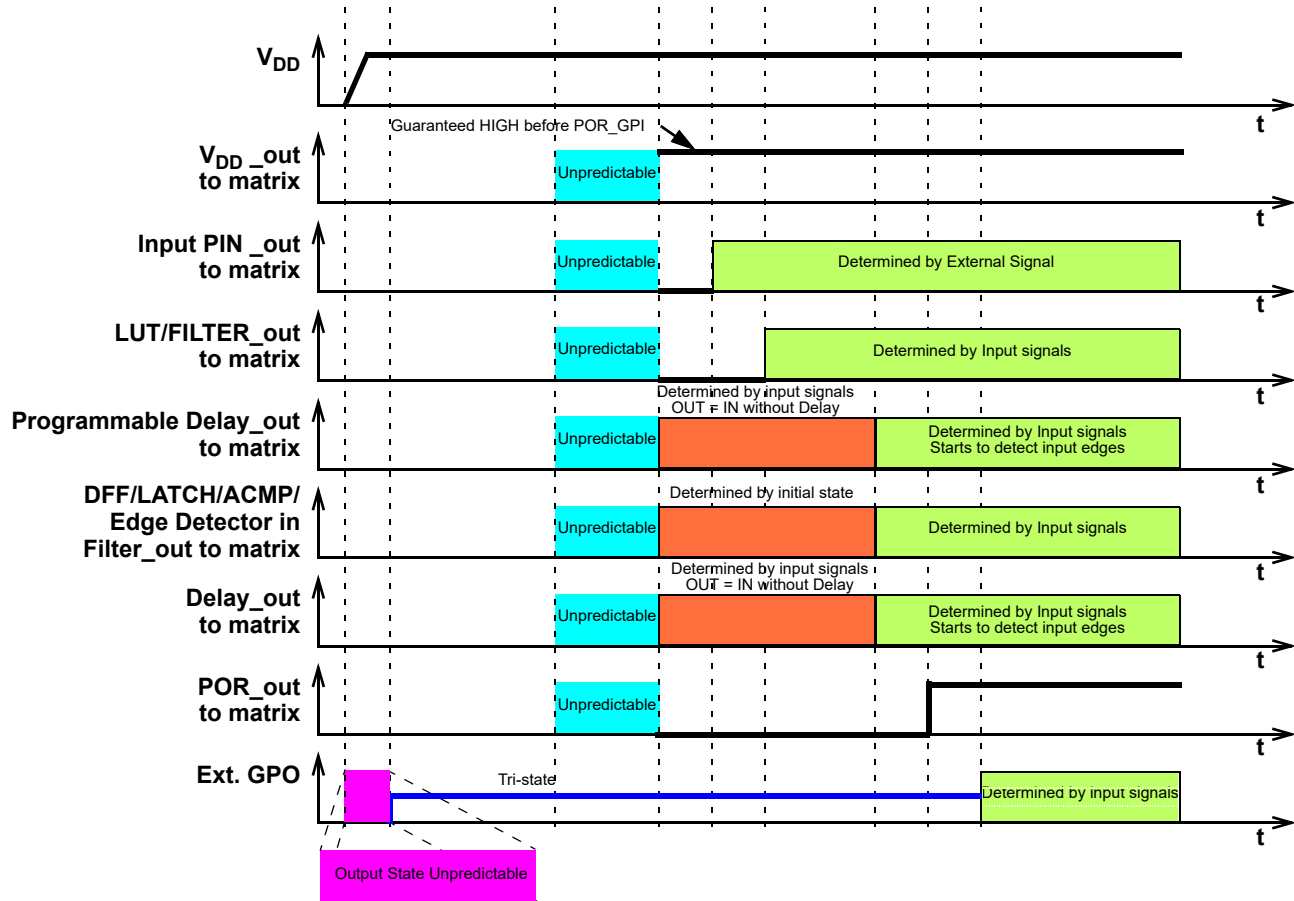

**Figure 97: Internal Macrocell States During POR Sequence**

### 14.3.1 Initialization

All internal macrocells by default have initial low level. Starting from indicated power-up time of 1.56 V to 2.03 V, macrocells in SLG46855-A are powered on while forced to the reset state. All outputs are in Hi-Z and chip starts loading data from NVM. Then the reset signal is released for internal macrocells and they start to initialize according to the following sequence:

1. Input pins, ACMP, Pull-up/down.
2. LUTs.
3. DFFs, Delays/Counters, Pipe Delay.
4. POR output to matrix.
5. Output pin corresponds to the internal logic.

The Vref output pin driving signal can precede POR output signal going high by 3 μs to 5 μs. The POR signal going high indicates the mentioned power-up sequence is complete.

**Note:** The maximum voltage applied to any pin should not be higher than the V<sub>DD</sub> level. There are ESD Diodes between pin → V<sub>DD</sub> and pin → GND on each pin. So, if the input signal applied to pin is higher than V<sub>DD</sub>, then current will sink through the diode to V<sub>DD</sub>. Exceeding V<sub>DD</sub> results in leakage current on the input pin, and V<sub>DD</sub> will be pulled up, following the voltage on the input pin. There is no effect from input pin when input voltage is applied at the same time as V<sub>DD</sub>.

SLG46855-A

Auto AEC-Q100 Qualified GreenPAK Programmable Mixed-Signal Matrix

14.3.2 Power-Down

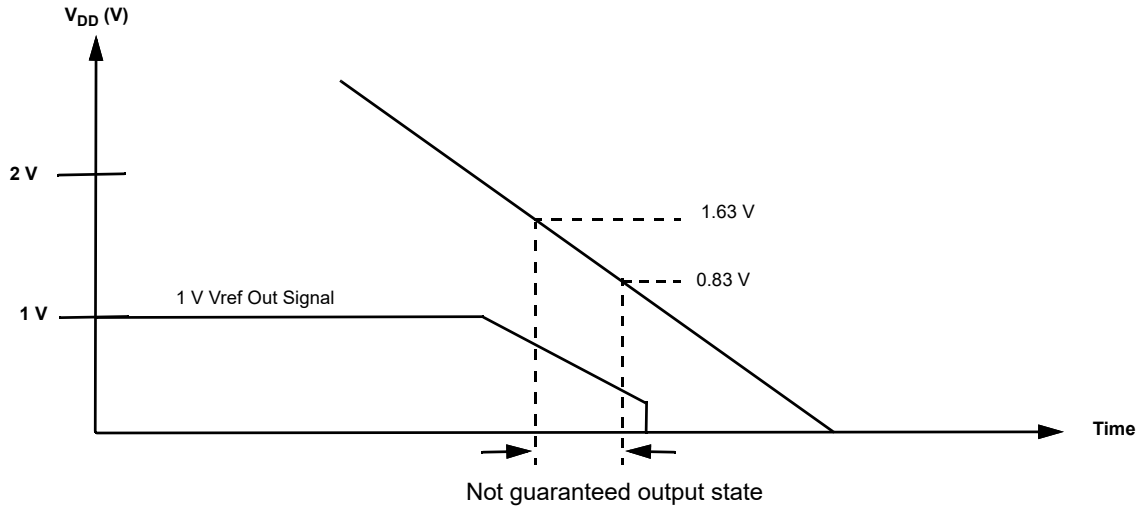

Figure 98: Power-Down

During power-down, macrocells in SLG46855-A are powered off after  $V_{DD}$  falling down below Power-Off Threshold. Please note that during a slow rampdown, outputs can possibly switch state during this time.

## 15 I<sup>2</sup>C Serial Communications Macrocell

### 15.1 I<sup>2</sup>C SERIAL COMMUNICATIONS MACROCELL OVERVIEW

In the standard use case for the GreenPAK devices, the configuration choices made by the user are stored as bit settings in the Non-Volatile Memory (NVM), and this information is transferred at startup time to volatile RAM registers that enable the configuration of the macrocells. Other RAM registers in the device are responsible for setting the connections in the Connection Matrix to route signals in the manner most appropriate for the user's application.

The I<sup>2</sup>C Serial Communications Macrocell in this device allows an I<sup>2</sup>C bus Master to read and write this information via a serial channel directly to the RAM registers, allowing the remote re-configuration of macrocells, and remote changes to signal chains within the device.

An I<sup>2</sup>C bus Master is also able to read and write other register bits that are not associated with NVM memory. As an example, the input lines to the Connection Matrix can be read as digital register bits. These are the signal outputs of each of the macrocells in the device, giving an I<sup>2</sup>C bus Master the capability to remotely read the current value of any macrocell.

The user has the flexibility to control read access and write access via registers bits registers [1967:1965]. See Section 15.5 for more details on I<sup>2</sup>C read/write memory protection.

### 15.2 I<sup>2</sup>C SERIAL COMMUNICATIONS DEVICE ADDRESSING

Each command to the I<sup>2</sup>C Serial Communications macrocell begins with a Control Byte. The bits inside this Control Byte are shown in Figure 99. After the Start bit, the first four bits are a control code. Each bit in a control code can be sourced independently from the register or by value defined externally GPIO0, GPIO2, GPIO4, and GPIO5. The LSB of the control code is defined by the value of GPIO0, while the MSB is defined by the value of GPIO5. The address source (either register bit or PIN) for each bit in the control code is defined by registers [2027:2024]. This gives the user flexibility on the chip level addressing of this device and other devices on the same I<sup>2</sup>C bus. The Block Address is the next three bits (A10, A9, A8), which will define the most significant bits in the addressing of the data to be read or written by the command. The last bit in the Control Byte is the R/W bit, which selects whether a read command or write command is requested, with a "1" selecting for a Read command, and a "0" selecting for a Write command. This Control Byte will be followed by an Acknowledge bit (ACK), which is sent by this device to indicate successful communication of the Control Byte data.

In the I<sup>2</sup>C-bus specification and user manual, there are two groups of eight addresses (0000 xxx and 1111 xxx) that are reserved for the special functions, such as a system General Call address. If the user of this device chooses to set the Control Code to either "1111" or "0000" in a system with other slave device, please consult the I<sup>2</sup>C-bus specification and user manual to understand the addressing and implementation of these special functions, to insure reliable operation.

In the read and write command address structure, there are a total of 11 bits of addressing, each pointing to a unique byte of information, resulting in a total address space of 2K bytes. Of this 2K byte address space, the valid addresses accessible to the I<sup>2</sup>C Macrocell on the SLG46855-A are in the range from 0 (0x00) to 255 (0xFF). The MSB address bits (A10, A9, and A8) will be "0" for all commands to the SLG46855-A.

With the exception of the Current Address Read command, all commands will have the Control Byte followed by the Word Address. Figure 99 shows this basic command structure.

SLG46855-A

Auto AEC-Q100 Qualified GreenPAK Programmable Mixed-Signal Matrix

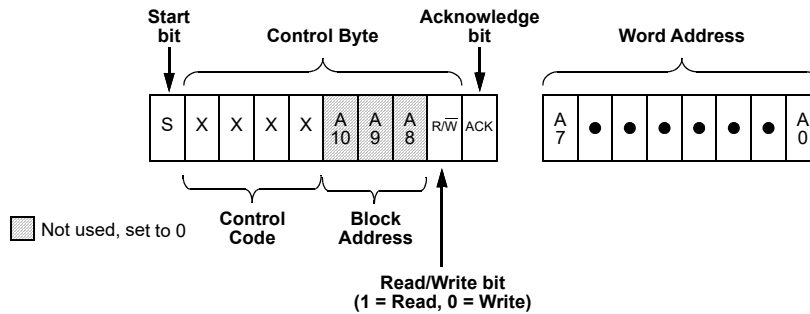

Figure 99: Basic Command Structure

15.3 I<sup>2</sup>C SERIAL GENERAL TIMING

General timing characteristics for the I<sup>2</sup>C Serial Communications macrocell are shown in Figure 100. Timing specifications can be found in the AC Characteristics section.

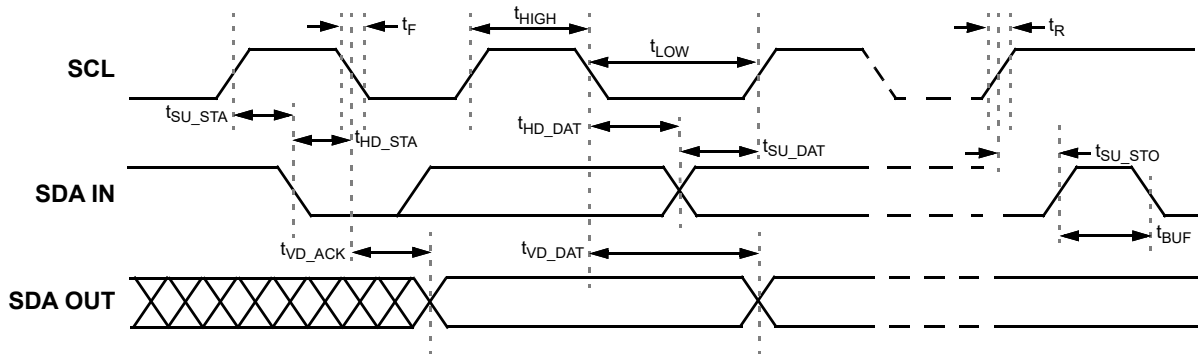

Figure 100: I<sup>2</sup>C General Timing Characteristics

15.4 I<sup>2</sup>C SERIAL COMMUNICATIONS COMMANDS

15.4.1 Byte Write Command

Following the Start condition from the Master, the Control Code [4 bits], the Block Address [3 bits], and the R/W bit (set to “0”) are placed onto the I<sup>2</sup>C bus by the Master. After the SLG46855-A sends an Acknowledge bit (ACK), the next byte transmitted by the Master is the Word Address. The Block Address (A10, A9, A8), combined with the Word Address (A7 through A0), together set the internal address pointer in the SLG46855-A, where the data byte is to be written. After the SLG46855-A sends another Acknowledge bit, the Master will transmit the data byte to be written into the addressed memory location. The SLG46855-A again provides an Acknowledge bit and then the Master generates a Stop condition. The internal write cycle for the data will take place at the time that the SLG46855-A generates the Acknowledge bit.

It is possible to latch all IOs during I<sup>2</sup>C write command, register [1961] = 1 - Enable. It means that IOs will remain their state until the write command is done.

SLG46855-A

Auto AEC-Q100 Qualified GreenPAK Programmable Mixed-Signal Matrix

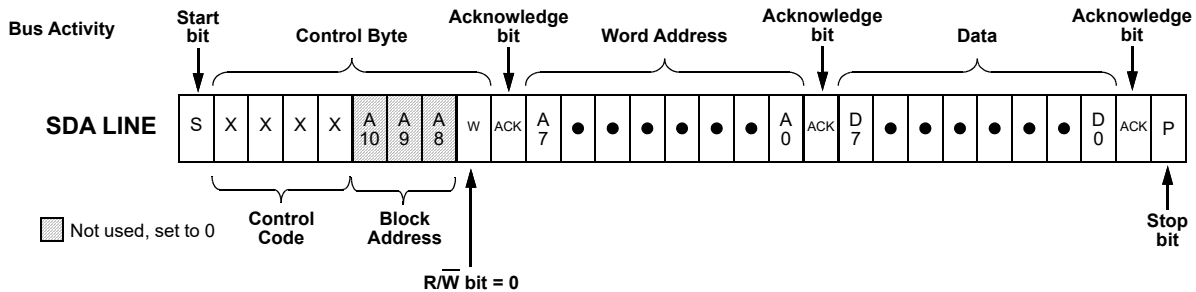

Figure 101: Byte Write Command,  $R/\bar{W} = 0$

15.4.2 Sequential Write Command

The write Control Byte, Word Address, and the first data byte are transmitted to the SLG46855-A in the same way as in a Byte Write command. However, instead of generating a Stop condition, the Bus Master continues to transmit data bytes to the SLG46855-A. Each subsequent data byte will increment the internal address counter, and will be written into the next higher byte in the command addressing. As in the case of the Byte Write command, the internal write cycle will take place at the time that the SLG46855-A generates the Acknowledge bit.

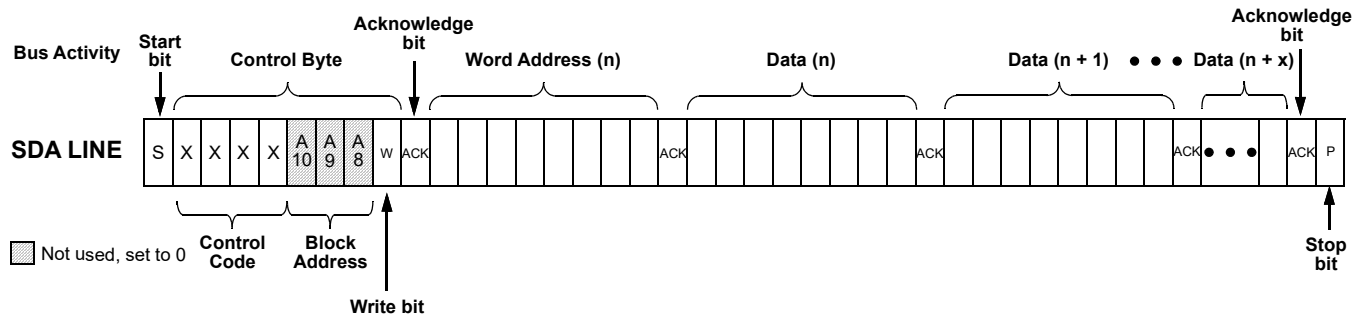

Figure 102: Sequential Write Command

15.4.3 Current Address Read Command

The Current Address Read Command reads from the current pointer address location. The address pointer is incremented at the first STOP bit following any write control byte. For example, if a Sequential Read command (which contains a write control byte) reads data up to address n, the address pointer would get incremented to n + 1 upon the STOP of that command. Subsequently, a Current Address Read that follows would start reading data at n + 1. The Current Address Read Command contains the Control Byte sent by the Master, with the  $R/\bar{W}$  bit = "1". The SLG46855-A will issue an Acknowledge bit, and then transmit eight data bits for the requested byte. The Master will not issue an Acknowledge bit, and follow immediately with a Stop condition.

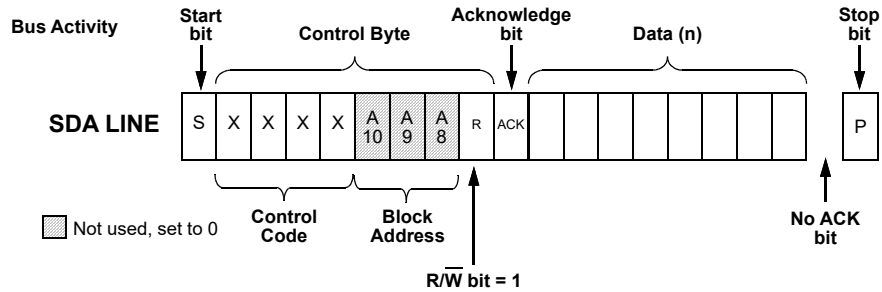

Figure 103: Current Address Read Command,  $\overline{R/W} = 1$

#### 15.4.4 Random Read Command

The Random Read command starts with a Control Byte (with R/W bit set to “0”, indicating a write command) and Word Address to set the internal byte address, followed by a Start bit, and then the Control Byte for the read (exactly the same as the Byte Write command). The Start bit in the middle of the command will halt the decoding of a Write command, but will set the internal address counter in preparation for the second half of the command. After the Start bit, the Bus Master issues a second control byte with the R/W bit set to “1”, after which the SLG46855-A issues an Acknowledge bit, followed by the requested eight data bits.

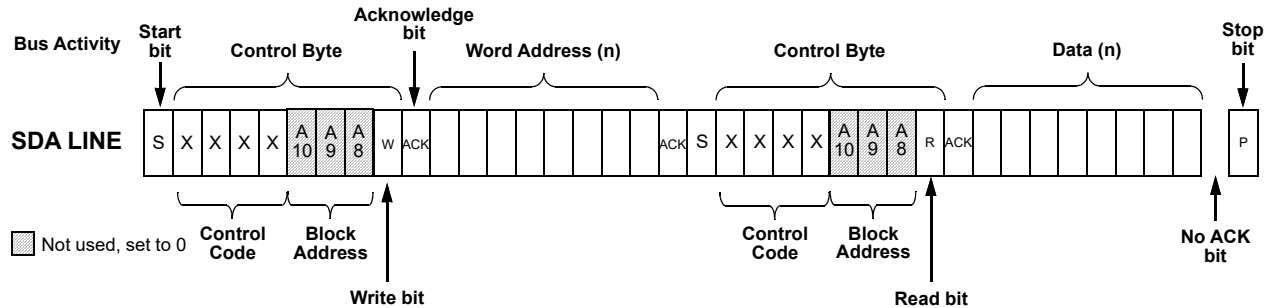

Figure 104: Random Read Command

SLG46855-A

Auto AEC-Q100 Qualified GreenPAK Programmable Mixed-Signal Matrix

15.4.5 Sequential Read Command

The Sequential Read command is initiated in the same way as a Random Read command, except that once the SLG46855-A transmits the first data byte, the Bus Master issues an Acknowledge bit as opposed to a Stop condition in a random read. The Bus Master can continue reading sequential bytes of data, and will terminate the command with a Stop condition.

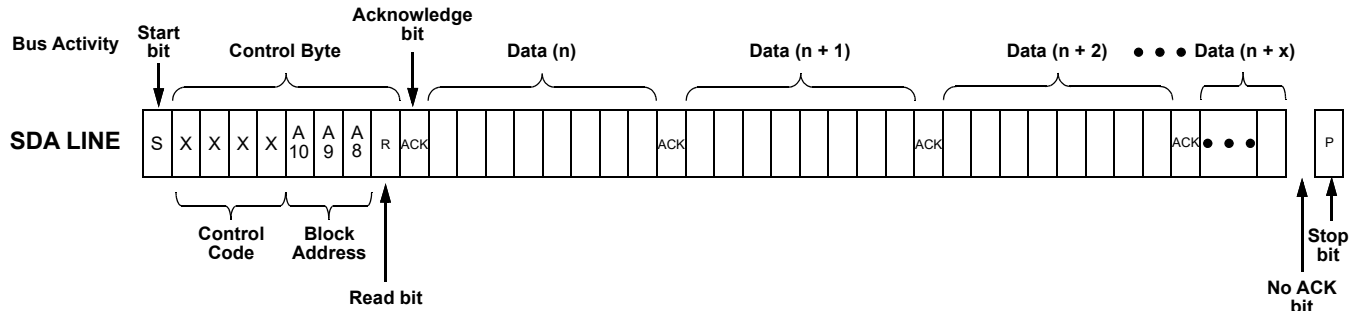

Figure 105: Sequential Read Command

15.4.6 I<sup>2</sup>C Serial Reset Command

If I<sup>2</sup>C serial communication is established with the device, it is possible to reset the device to initial power up conditions, including configuration of all macrocells, and all connections provided by the Connection Matrix. This is implemented by setting register [1960] I<sup>2</sup>C reset bit to “1”, which causes the device to re-enable the Power-On Reset (POR) sequence, including the reload of all register data from NVM. During the POR sequence, the outputs of the device will be in tri-state. After the reset has taken place, the contents of register [1960] will be set to “0” automatically. The Figure 106 illustrates the sequence of events for this reset function.

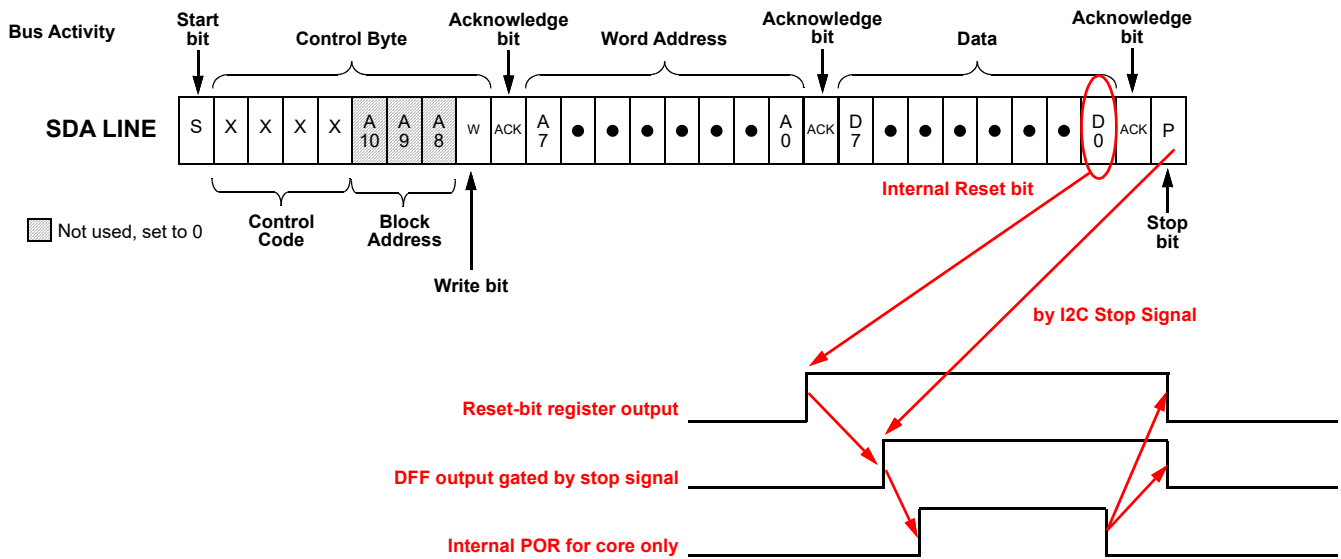

Figure 106: Reset Command Timing



# SLG46855-A

## Auto AEC-Q100 Qualified GreenPAK Programmable Mixed-Signal Matrix

### 15.5 I<sup>2</sup>C SERIAL COMMAND REGISTER MAP

There are seven read/write protect modes for the design sequence from being corrupted or copied. See [Table 55](#) for details.

**Table 56: Read/Write Protection Options**

Configurations	Protection Modes Configuration							Data Output From	Register Address
	Unlocked	Partly Lock Read1	Partly Lock Read2	Partly Lock Read2/Write	Lock Read	Lock Write	Lock Read/Write		
	(Mode 0)	(Mode 1)	(Mode 2)	(Mode 3)	(Mode 4)	(Mode 5)	(Mode 6)		
I <sup>2</sup> C Byte Write Bit Masking (section 15.6.3)	R/W	R/W	R/W	R/W	W	R	-	Memory	F6
I <sup>2</sup> C Serial Reset Command (section 15.4.6)	R/W	R/W	R/W	R/W	W	R	-	Memory	F5,b'0
Outputs Latching During I <sup>2</sup> C Write	R/W	R/W	R/W	R/W	W	R	-	Memory	F5,b'1
Connection Matrix Virtual Inputs (section 6.3)	R/W	R/W	R/W	R/W	W	R	-	Macrocell	4C
Configuration Bits for All Macrocells (IO Pins, ACMPs, Combination Function Macrocells, etc.)	R/W	R/W	W	-	W	R	-	Memory	
Macrocells Inputs Configuration (Connection Matrix Outputs, section 6.2)	R/W	W	W	-	W	R	-	Memory	0~47
Protection Mode Enable	R	R	R	R	R	R	R	Memory	F5,b'3
Protection Mode Selection	R/W	R	R	R	R	R	R	Memory	F5,b'7~5
Macrocells Output Values (Connection Matrix Inputs, section 6.1)	R	R	R	R	-	R	-	Macrocell	48~4B; 4D~4F
Counter Current Value (for 16-bit CNT)	R	R	R	R	-	R	-	Macrocell	A5,A6
Counter Current Value (for 8-bit CNT)	R	R	R	R	-	R	-	Macrocell	A7,A8
I <sup>2</sup> C Control Code (section 15.2)	R	R	R	R	R	R	R	Memory	FD,b'3~0
Pin Slave Address Select	R	R	R	R	R	R	R	Memory	FD,b'7~4
I <sup>2</sup> C Disable/Enable	R	R	R	R	R	R	R	Memory	FE,b'0

## Auto AEC-Q100 Qualified GreenPAK Programmable Mixed-Signal Matrix

R/W	Allow Read and Write Data
W	Allow Write Data Only
R	Allow Read Data Only
-	The Data is protected for Read and Write

It is possible to read some data from macrocells, such as counter current value, connection matrix, and connection matrix virtual inputs. The I<sup>2</sup>C write will not have any impact on data in case data comes from macrocell output, except Connection Matrix Virtual Inputs. The silicon identification service bits allows identifying silicon family, its revision, and others.

See Section 17 for detailed information on all registers.

### 15.6 I<sup>2</sup>C ADDITIONAL OPTIONS

When Output latching during I<sup>2</sup>C write, register [1961] = 1 allows all PINs output value to be latched until I<sup>2</sup>C write is done. It will protect the output change due to configuration process during I<sup>2</sup>C write in case multiple register bytes are changed. Inputs and internal macrocells retain their status during I<sup>2</sup>C write.

If the user sets GPIO0 and GPIO1 function to a selection other than SDA and SCL, all access via I<sup>2</sup>C will be disabled.

**Note:** Any write commands that come to the device via I<sup>2</sup>C that are not blocked, based on the protection bits, will change the contents of the RAM register bits that mirror the NVM bits. These write commands will not change the NVM bits themselves, and a POR event will restore the register bits to original programmed contents of the NVM.

See Section 17 for detailed information on all registers.

#### 15.6.1 Reading Counter Data via I<sup>2</sup>C

The current count value in three counters in the device can be read via I<sup>2</sup>C. The counters that have this additional functionality are 16-bit CNT0, and 8-bit counters CNT6 and CNT7.

#### 15.6.2 I<sup>2</sup>C Expander

In addition to the eight Connection Matrix Virtual Inputs, the SLG46855-A chip has four pins which can be used as an I<sup>2</sup>C Expander. These four pins are GPO0, GPIO6, GPIO7, and GPIO8.

Each of these pins can be used as an I<sup>2</sup>C Expander output or used as a normal pin. Also, each of these four expander outputs have initial state settings which are specified in registers [1959:1952].

# SLG46855-A

## Auto AEC-Q100 Qualified GreenPAK Programmable Mixed-Signal Matrix

### 15.6.3 I<sup>2</sup>C Byte Write Bit Masking

The I<sup>2</sup>C macrocell inside SLG46855-A supports masking of individual bits within a byte that is written to the RAM memory space. This function is supported across the entire RAM memory space. To implement this function, the user performs a Byte Write Command (see Section 15.4.1 for details) on the I<sup>2</sup>C Byte Write Mask Register (address 0F6H) with the desired bit mask pattern. This sets a bit mask pattern for the target memory location that will take effect on the next Byte Write Command to this register byte. Any bit in the mask that is set to “1” in the I<sup>2</sup>C Byte Write Mask Register will mask the effect of changing that particular bit in the target register, during the next Byte Write Command. The contents of the I<sup>2</sup>C Byte Write Mask Register are reset (set to 00h) after valid Byte Write Command. If the next command received by the device is not a Byte Write Command, the effect of the bit masking function will be aborted, and the I<sup>2</sup>C Byte Write Mask Register will be reset with no effect. Figure 107 shows an example of this function.

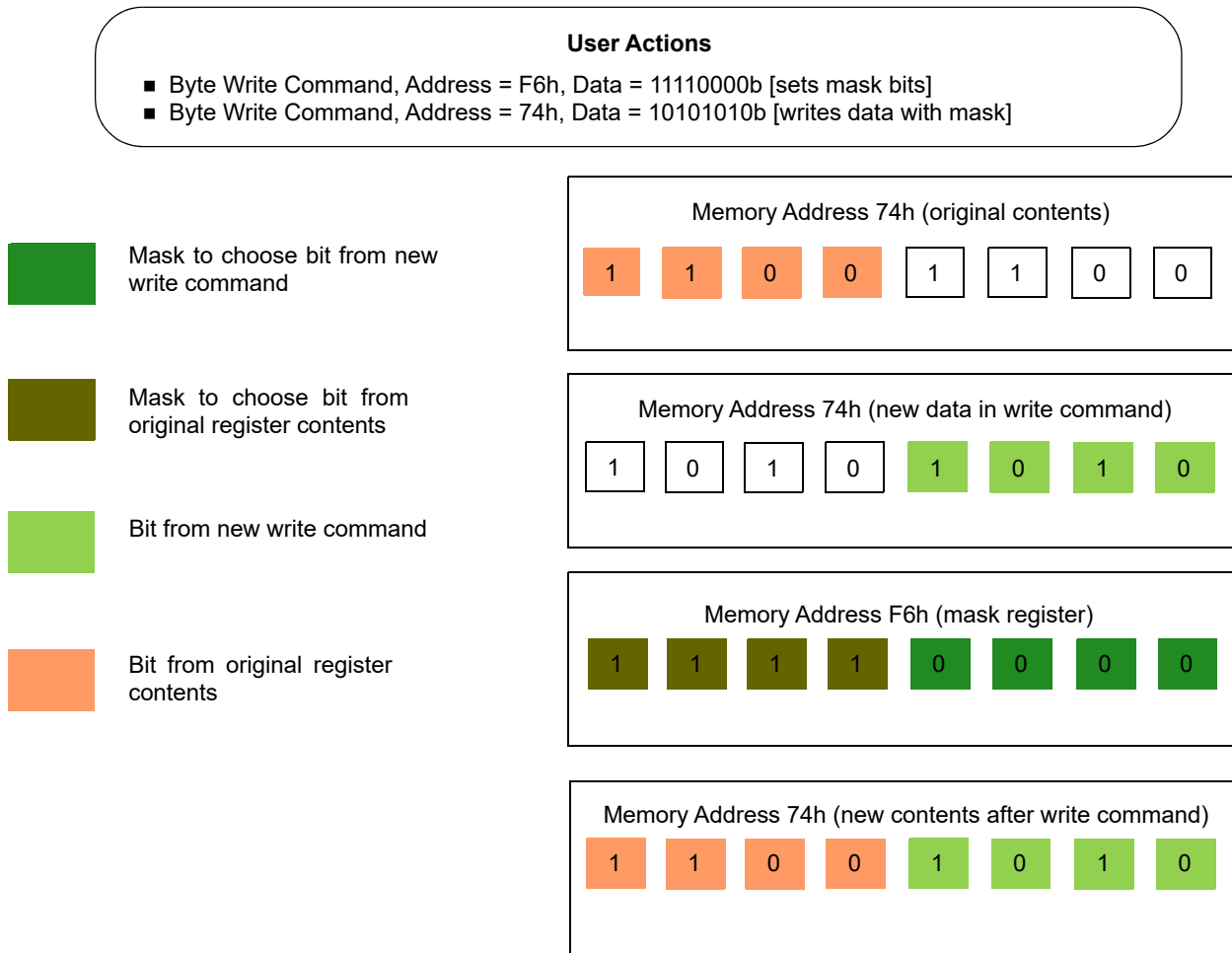

Figure 107: Example of I<sup>2</sup>C Byte Write Bit Masking

## 16 Analog Temperature Sensor

The SLG46855-A has an Analog Temperature sensor (TS) with an output voltage linearly-proportional to the Centigrade temperature. The TS cell shares buffer with Vref 0, so it is impossible to use both cells simultaneously, its output can be connected directly to the GPIO8 or to the ACPM3\_L positive input. Using buffer causes low-output impedance, linear output, and makes interfacing to readout or control circuitry especially easy. The TS is rated to operate over a -40 °C to 105 °C temperature range. The error in the whole temperature range does not exceed ±1.5 %. For more detail refer to section 3.11.

The equation below calculates the typical analog voltage passed from the TS to the ACMPs' IN+ source input for  $V_{DD} = 2.3\text{ V}$  to 5.5 V. It is important to note that there will be a chip to chip variation of about ±2 °C.

$$V_{TS1} = -2.3 \times T + 906.2$$

$$V_{TS2} = -2.8 \times T + 1094.3$$

where:

$V_{TS1}$  (mV) - TS Output Voltage, range 1

$V_{TS2}$  (mV) - TS Output Voltage, range 2

T (°C) - Temperature

Temperature hysteresis can be setup by enabling the GreenPAK's internal ACMP hysteresis.

SLG46855-A

Auto AEC-Q100 Qualified GreenPAK Programmable Mixed-Signal Matrix

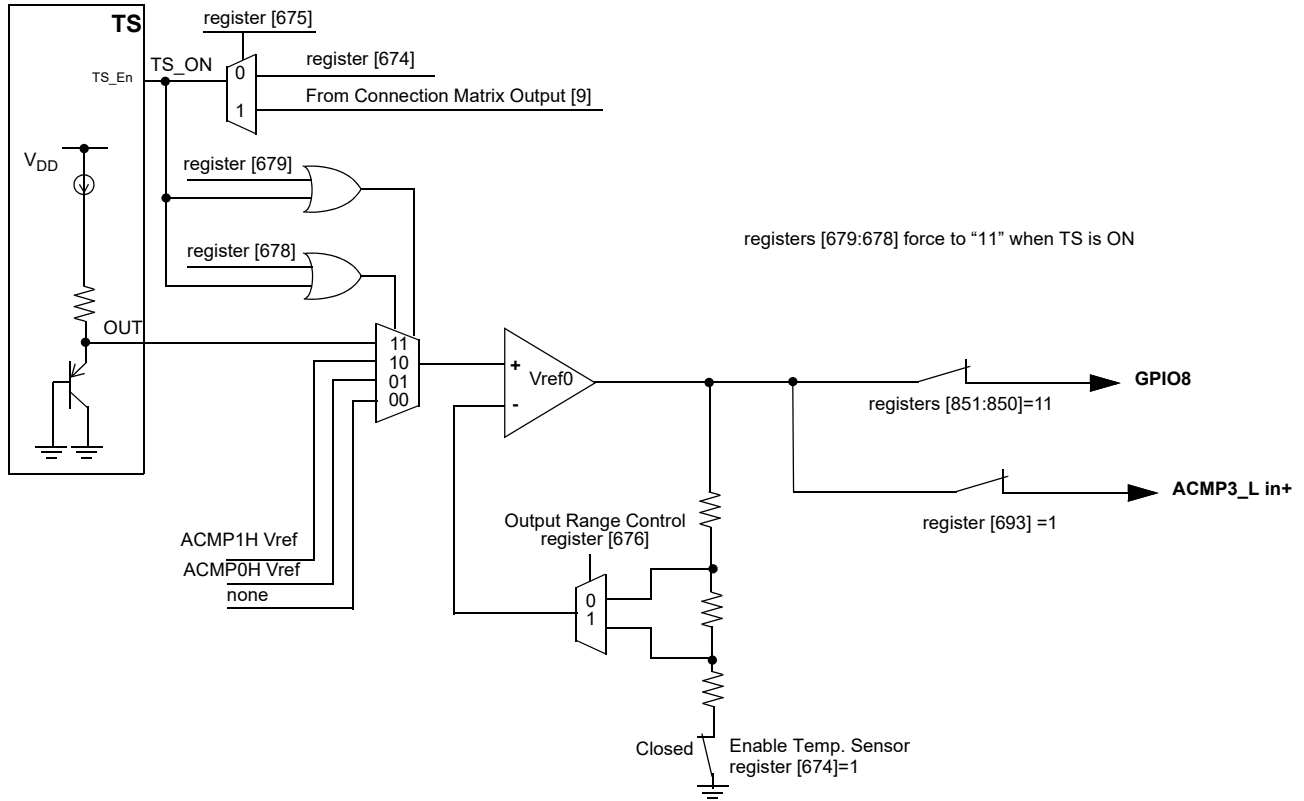

Figure 108: Analog Temperature Sensor Structure Diagram

SLG46855-A

Auto AEC-Q100 Qualified GreenPAK Programmable Mixed-Signal Matrix

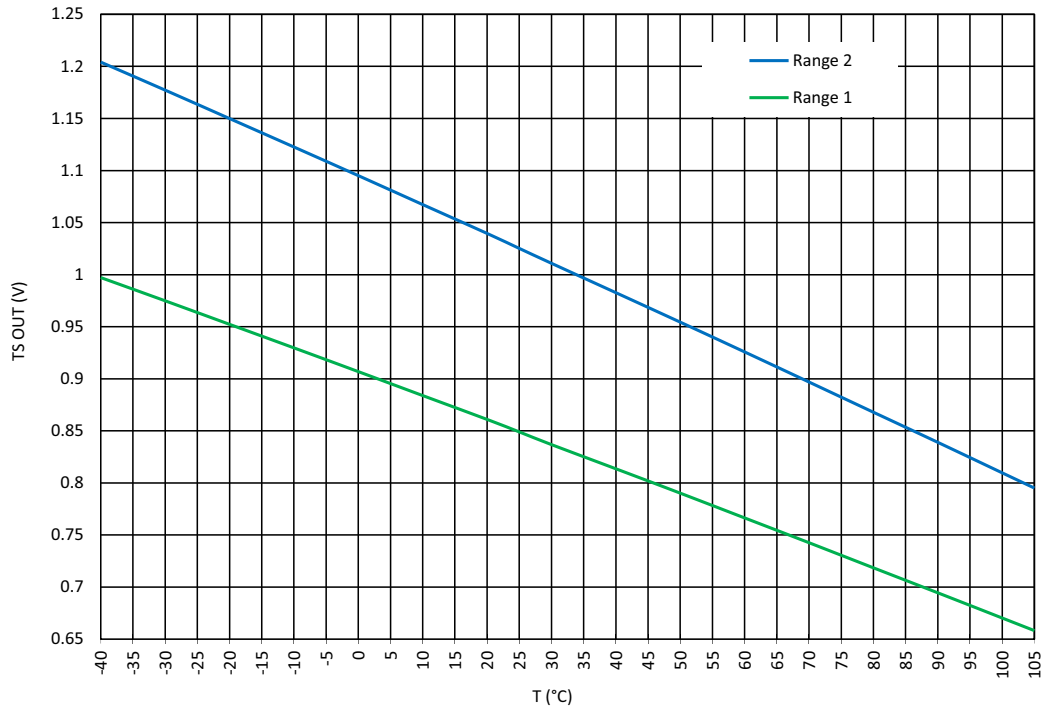

Figure 109: TS Output vs. Temperature,  $V_{DD} = 2.3\text{ V to }5.5\text{ V}$

# SLG46855-A

## Auto AEC-Q100 Qualified GreenPAK Programmable Mixed-Signal Matrix

### 17 Register Definitions

#### 17.1 REGISTER MAP

Table 57: Register Map

Address		Signal Function	Register Bit Definition
Byte	Register Bit		
<b>Matrix Output</b>			
0	0	LUT2_0 & DFF0	OUT0: IN0 of LUT2_0 or Clock Input of DFF0
	1		
	2		
	3		
	4		
	5		
	6		
	7		
1	8	LUT2_1 & DFF1	OUT1 IN1 of LUT2_0 or Data Input of DFF0
	9		
	10		
	11		
	12		
	13		
	14		
	15		
2	16	LUT2_1 & DFF1	OUT2: IN0 of LUT2_1 or Clock Input of DFF1
	17		
	18		
	19		
	20		
	21		
	22		
	23		
			OUT3: IN1 of LUT2_1 or Data Input of DFF1

# SLG46855-A

## Auto AEC-Q100 Qualified GreenPAK Programmable Mixed-Signal Matrix

**Table 57: Register Map** (Continued)

Address		Signal Function	Register Bit Definition
Byte	Register Bit		
3	24	LUT2_2 & DFF2	OUT4: IN0 of LUT2_2 or Clock Input of DFF2
	25		
	26		
	27		
	28		
	29		
	30		
4	31	LUT2_3 & PGen	OUT5: IN1 of LUT2_2 or Data Input of DFF2
	32		
	33		
	34		
	35		
	36		
	37		
5	38	LUT2_3 & PGen	OUT6: IN0 of LUT2_3 or Clock Input of PGen
	39		
	40		
	41		
	42		
	43		
	44		
6	45	LUT3_0 & DFF3	OUT7: IN1 of LUT2_3 or nRST of PGen
	46		
	47		
	48		
	49		
	50		
	51		
7	52	LUT3_0 & DFF3	OUT8: IN0 of LUT3_0 or CLK Input of DFF3
	53		
	54		
	55		
	56		
	57		
	58		
8	59	LUT3_1 & DFF4	OUT9: IN1 of LUT3_0 or Data of DFF3
	60		
	61		
	62		
	63		
	64		
	65		
8	66	LUT3_1 & DFF4	OUT10: IN2 of LUT3_0 or nRST (nSET) of DFF3
	67		
	68		
	69		
	70		
	71		
8	66	LUT3_1 & DFF4	OUT11: IN0 of LUT3_1 or CLK Input of DFF4
	67		
	68		
	69		
	70		
	71		



# SLG46855-A

## Auto AEC-Q100 Qualified GreenPAK Programmable Mixed-Signal Matrix

**Table 57: Register Map (Continued)**

Address		Signal Function	Register Bit Definition
Byte	Register Bit		
9	72	LUT3_1 & DFF4	OUT12: IN1 of LUT3_1 or Data of DFF4
	73		
	74		
	75		
	76		
	77		
	78		
	79		
A	80	LUT3_2 & DFF5	OUT13: IN2 of LUT3_1 or nRST (nSET) of DFF4
	81		
	82		
	83		
	84		
	85		
	86		
	87		
B	88	LUT3_2 & DFF5	OUT14: IN0 of LUT3_2 or CLK Input of DFF5
	89		
	90		
	91		
	92		
	93		
	94		
	95		
C	96	LUT3_3 & DFF6	OUT15: IN1 of LUT3_2 or Data of DFF5
	97		
	98		
	99		
	100		
	101		
	102		
	103		
D	104	LUT3_3 & DFF6	OUT16: IN2 of LUT3_2 or nRST (nSET) of DFF5
	105		
	106		
	107		
	108		
	109		
	110		
	111		
E	112	LUT3_3 & DFF6	OUT17: IN0 of LUT3_3 or CLK Input of DFF6
	113		
	114		
	115		
	116		
	117		
	118		
	119		
	112	LUT3_3 & DFF6	OUT18: IN1 of LUT3_3 or Data of DFF6
	113		
	114		
	115		
	116		
	117		
	118		
	119		
	112	LUT3_3 & DFF6	OUT19: IN2 of LUT3_3 or nRST (nSET) of DFF6
	113		
	114		
	115		
	116		
	117		
	118		
	119		

**Auto AEC-Q100 Qualified GreenPAK Programmable Mixed-Signal Matrix**
**Table 57: Register Map (Continued)**

Address		Signal Function	Register Bit Definition
Byte	Register Bit		
F	120	LUT3_4 & DFF7	OUT20: IN0 of LUT3_4 or CLK Input of DFF7
	121		
	122		
	123		
	124		
	125		
	126		
10	127	LUT3_4 & DFF7	OUT21: IN1 of LUT3_4 or Data of DFF7
	128		
	129		
	130		
	131		
	132		
	133		
11	134	LUT3_5 & DFF8	OUT22: IN2 of LUT3_4 or nRST (nSET) of DFF7
	135		
	136		
	137		
	138		
	139		
	140		
12	141	LUT3_5 & DFF8	OUT23: IN0 of LUT3_5 or CLK Input of DFF8
	142		
	143		
	144		
	145		
	146		
	147		
13	148	LUT3_5 & DFF8	OUT24: IN1 of LUT3_5 or Data of DFF8
	149		
	150		
	151		
	152		
	153		
	154		
14	155	LUT3_6 & DFF9	OUT25: IN2 of LUT3_5 or nRST (nSET) of DFF8
	156		
	157		
	158		
	159		
	160		
	161		
14	162	LUT3_6 & DFF9	OUT26: IN0 of LUT3_6 or CLK Input of DFF9
	163		
	164		
	165		
	166		
	167		
	167		
14	167	LUT3_6 & DFF9	OUT27: IN1 of LUT3_6 or Data of DFF9
	167		
	167		
	167		
	167		
	167		
	167		

# SLG46855-A

## Auto AEC-Q100 Qualified GreenPAK Programmable Mixed-Signal Matrix

**Table 57: Register Map (Continued)**

Address		Signal Function	Register Bit Definition
Byte	Register Bit		
15	168	LUT3_6 & DFF9	OUT28: IN2 of LUT3_6 or nRST (nSET) of DFF9
	169		
	170		
	171		
	172		
	173		
	174		
16	176	LUT3_7 & DFF10	OUT29: IN0 of LUT3_7 or CLK Input of DFF10
	177		
	178		
	179		
	180		
	181		
	182		
17	183	LUT3_7 & DFF10	OUT30: IN1 of LUT3_7 or Data of DFF10
	184		
	185		
	186		
	187		
	188		
	189		
18	190	LUT3_8 & DFF11	OUT31: IN2 of LUT3_7 or nRST (nSET) of DFF10
	191		
	192		
	193		
	194		
	195		
	196		
19	197	LUT3_8 & DFF11	OUT32: IN0 of LUT3_8 or CLK Input of DFF11
	198		
	199		
	200		
	201		
	202		
	203		
1A	204	Multi_function4	OUT33: IN1 of LUT3_8 or Data of DFF11
	205		
	206		
	207		
	208		
	209		
	210		
1A	211	Multi_function4	OUT34: IN2 of LUT3_8 or nRST (nSET) of DFF11
	212		
	213		
	214		
	215		
1A	211	Multi_function4	OUT35: IN0 of LUT3_12 or CLK Input of DFF16 Delay4 Input (or Counter4 nRST Input)
	212		
	213		
	214		
	215		

# SLG46855-A

## Auto AEC-Q100 Qualified GreenPAK Programmable Mixed-Signal Matrix

**Table 57: Register Map (Continued)**

Address		Signal Function	Register Bit Definition
Byte	Register Bit		
1B	216	Multi_function4	OUT36: IN1 of LUT3_12 or nRST (nSET) of DFF16 Delay4 Input $\bar{}$ (or Counter4 nRST Input)
	217		
	218		
	219		
	220		
	221		
	222		
1C	223	Multi_function4	OUT37: IN2 of LUT3_12 or Data of DFF16 Delay4 Input $\bar{}$ (or Counter4 nRST Input)
	224		
	225		
	226		
	227		
	228		
	229		
1D	230	Multi_function5	OUT38: IN0 of LUT3_13 or CLK Input of DFF17 Delay5 Input $\bar{}$ (or Counter5 nRST Input)
	231		
	232		
	233		
	234		
	235		
	236		
1E	237	Multi_function5	OUT39: IN1 of LUT3_13 or nRST (nSET) of DFF17 Delay5 Input $\bar{}$ (or Counter5 nRST Input)
	238		
	239		
	240		
	241		
	242		
	243		
1F	244	Multi_function6	OUT40: IN2 of LUT3_13 or Data of DFF17 Delay5 Input $\bar{}$ (or Counter5 nRST Input)
	245		
	246		
	247		
	248		
	249		
	250		
20	251	Multi_function6	OUT41: IN0 of LUT3_14 or CLK Input of DFF18 Delay6 Input $\bar{}$ (or Counter6 nRST Input)
	252		
	253		
	254		
	255		
	256		
	257		
20	258	Multi_function6	OUT42: IN1 of LUT3_14 or nRST (nSET) of DFF18 Delay6 Input $\bar{}$ (or Counter6 nRST Input)
	259		
	260		
	261		
	262		
	263		
	263		
20	260	Multi_function6	OUT43: IN2 of LUT3_14 or Data of DFF18 Delay6 Input $\bar{}$ (or Counter6 nRST Input)
	261		
	262		
	263		
	263		
	263		
	263		

**Auto AEC-Q100 Qualified GreenPAK Programmable Mixed-Signal Matrix**
**Table 57: Register Map (Continued)**

Address		Signal Function	Register Bit Definition
Byte	Register Bit		
21	264	Multi_function7	OUT44: IN0 of LUT3_15 or CLK Input of DFF19 Delay7 Input $\bar{}$ (or Counter7 nRST Input)
	265		
	266		
	267		
	268		
	269		
	270		
22	271	Multi_function7	OUT45: IN1 of LUT3_15 or nRST (nSET) of DFF19 Delay7 Input $\bar{}$ (or Counter7 nRST Input)
	272		
	273		
	274		
	275		
	276		
	277		
23	278	LUT3_16 & Pipe Delay (RIPP CNT)	OUT46: IN2 of LUT3_15 or Data of DFF19 Delay7 Input $\bar{}$ (or Counter7 nRST Input)
	279		
	280		
	281		
	282		
	283		
	284		
24	285	LUT3_16 & Pipe Delay (RIPP CNT)	OUT47: IN0 of LUT3_16 or Input of Pipe Delay or UP signal of RIPP CNT
	286		
	287		
	288		
	289		
	290		
	291		
25	292	LUT3_16 & Pipe Delay (RIPP CNT)	OUT48: IN1 of LUT3_16 or nRST of Pipe Delay or nSET of RIPP CNT
	293		
	294		
	295		
	296		
	297		
	298		
26	299	LUT4_DFF12	OUT49: IN2 of LUT3_16 or Clock of Pipe Delay_RIPP CNT
	300		
	301		
	302		
	303		
	304		
	305		
26	306	LUT4_DFF12	OUT50: IN0 of LUT4_0 or CLK Input of DFF12
	307		
	308		
	309		
	310		
	311		
	311		
26	311	LUT4_DFF12	OUT51: IN1 of LUT4_0 or Data of DFF12

# SLG46855-A

## Auto AEC-Q100 Qualified GreenPAK Programmable Mixed-Signal Matrix

**Table 57: Register Map (Continued)**

Address		Signal Function	Register Bit Definition
Byte	Register Bit		
27	312	LUT4_DFF12	OUT52: IN2 of LUT4_0 or nRST (nSET) of DFF12
	313		
	314		
	315		
	316		
	317		
	318		
28	319	Programmable delay	OUT54: Programmable delay/edge detect input
	320		
	321		
	322		
	323		
	324		
	325		
29	326	Filter/Edge Detect	OUT55: Filter/Edge detect input
	327		
	328		
	329		
	330		
	331		
	332		
2A	333	GPIO0	OUT56: GPIO0 DOUT
	334		
	335		
	336		
	337		
	338		
	339		
2B	340	GPIO1	OUT57: GPIO1 DOUT
	341		
	342		
	343		
	344		
	345		
	346		
2C	347	GPIO2	OUT58: GPIO2 DOUT
	348		
	349		
	350		
	351		
	352		
	353		
2C	354	GPIO2	OUT59: GPIO2 DOUT OE
	355		
	356		
	357		
2C	358	GPIO2	OUT59: GPIO2 DOUT OE
	359		
	359		

# SLG46855-A

## Auto AEC-Q100 Qualified GreenPAK Programmable Mixed-Signal Matrix

**Table 57: Register Map (Continued)**

Address		Signal Function	Register Bit Definition
Byte	Register Bit		
2D	360	GPIO3 DOUT and Input of Power Switch ON0	OUT60: GPIO3 DOUT and Input of Power Switch ON0
	361		
	362		
	363		
	364		
	365		
	366		
2E	367	GPO0 and Input of Power Switch ON1	OUT61: GPIO3 DOUT OE
	368		
	369		
	370		
	371		
	372		
	373		
2F	374	GPIO4	OUT62: GPO0 DOUT and Input of Power Switch ON1
	375		
	376		
	377		
	378		
	379		
	380		
30	381	GPIO4	OUT63: GPIO4 DOUT
	382		
	383		
	384		
	385		
	386		
	387		
31	388	GPIO5	OUT64: GPIO4 DOUT OE
	389		
	390		
	391		
	392		
	393		
	394		
32	395	GPIO6	OUT65: GPIO5 DOUT
	396		
	397		
	398		
	399		
	400		
	401		
32	402	GPIO6	OUT66: GPIO5 DOUT OE
	403		
	404		
	405		
	406		
	407		
32	402	GPIO6	OUT67: GPIO6 DOUT
	403		
	404		
	405		
	406		
	407		

# SLG46855-A

## Auto AEC-Q100 Qualified GreenPAK Programmable Mixed-Signal Matrix

**Table 57: Register Map (Continued)**

Address		Signal Function	Register Bit Definition
Byte	Register Bit		
33	408	GPIO6	OUT68: GPIO6 DOUT OE
	409		
	410		
	411		
	412		
	413		
	414		
34	416	GPIO7	OUT69: GPIO7 DOUT
	417		
	418		
	419		OUT70: GPIO7 DOUT OE
	420		
	421		
	422		
35	423	GPIO8	OUT71: GPIO8 DOUT
	424		
	425		
	426		
	427		
	428		
	429		
36	430	GPIO8	OUT72: GPIO8 DOUT OE
	431		
	432		
	433		
	434		
	435		
	436		
37	437	GPIO9	OUT73: GPIO9 DOUT
	438		
	439		
	440		OUT74: GPIO9 DOUT OE
	441		
	442		
	443		
38	444	ACMP0H	OUT75: PWR UP of ACMP0H
	445		
	446		
	447		
	448		
	449		
	450		
451			
452			
453			
454			
455			



# SLG46855-A

## Auto AEC-Q100 Qualified GreenPAK Programmable Mixed-Signal Matrix

**Table 57: Register Map (Continued)**

Address		Signal Function	Register Bit Definition		
Byte	Register Bit				
39	456	ACMP1H	OUT76: PWR UP of ACMP1H		
	457				
	458				
	459				
	460				
	461				
	462				
3A	464	ACMP2L	OUT77: PWR UP of ACMP2L		
	465				
	466				
	467				
	468				
	469				
	470				
3B	471	ACMP3L	OUT78: PWR UP of ACMP3L		
	472				
	473				
	474				
	475				
	476			Temp Sensor	OUT79: Temp sensor, Vref Out_0, Vref Out_1 Power Up
	477				
478					
3C	479	OSC0	OUT80: OSC0 ENABLE		
	480				
	481				
	482				
	483				
	484				
	485				
3D	486	OSC1	OUT81: OSC1 ENABLE		
	487				
	488				
	489				
	490				
	491				
	492				
3E	493	OSC2	OUT82: OSC2 ENABLE		
	494				
	495				
	496				
	497				
	498				
	499				
3E	500	Multi_function0	OUT83: IN0 of LUT4_1 or CLK Input of DFF20 Delay0 Input (or Counter0 nRST Input)		
	501				
	502				
	503				

# SLG46855-A

## Auto AEC-Q100 Qualified GreenPAK Programmable Mixed-Signal Matrix

**Table 57: Register Map (Continued)**

Address		Signal Function	Register Bit Definition
Byte	Register Bit		
3F	504	Multi_function0	OUT84: IN1 of LUT4_1 or nRST of DFF20 Delay0 Input (or Counter0 nRST Input) Delay/Counter0 External CLK source
	505		
	506		
	507		
	508		
	509		
	510		
40	511		OUT85: IN2 of LUT4_1 or nSET of DFF20 Delay0 Input (or Counter0 nRST Input) Delay/Counter0 External CLK source KEEP Input of FSM0
	512		
	513		
	514		
	515		
	516		
	517		
41	518	OUT86: IN3 of LUT4_1 or Data of DFF20 Delay0 Input (or Counter0 nRST Input) UP Input of FSM0	
	519		
	520		
	521		
	522	OUT87: IN0 of LUT3_9 or CLK Input of DFF13 Delay1 Input (or Counter1 nRST Input)	
	523		
	524		
525			
526			
527			
42	528	Multi_function1	OUT88: IN1 of LUT3_9 or nRST (nSET) of DFF13 Delay1 Input (or Counter1 nRST Input)
	529		
	530		
	531		
	532		
	533		
	534		
43	535	OUT89: IN2 of LUT3_9 or Data of DFF13 Delay1 Input (or Counter1 nRST Input)	
	536		
	537		
	538		
	539		
	540	OUT90: IN0 of LUT3_10 or CLK Input of DFF14 Delay2 Input (or Counter2 nRST Input)	
	541		
542			
543			
544			
545			
44	546	Multi_function2	OUT91: IN1 of LUT3_10 or nRST (nSET) of DFF14 Delay2 Input (or Counter2 nRST Input)
	547		
	548		
	549		
	550		
	551		

**Auto AEC-Q100 Qualified GreenPAK Programmable Mixed-Signal Matrix**
**Table 57: Register Map (Continued)**

Address		Signal Function	Register Bit Definition		
Byte	Register Bit				
45	552	Multi_function2	OUT92: IN2 of LUT3_10 or Data of DFF14 Delay2 Input $\bar{}$ (or Counter2 nRST Input)		
	553				
	554				
	555				
	556				
	557				
	558				
46	559	Multi_function3	OUT93: IN0 of LUT3_11 or CLK Input of DFF15 Delay3 Input $\bar{}$ (or Counter3 nRST Input)		
	560				
	561				
	562				
	563				
	564				
	565				
47	566			OUT94: IN1 of LUT3_11 or nRST (nSET) of DFF15 Delay3 Input $\bar{}$ (or Counter3 nRST Input)	
	567				
	568				
	569				
	570				
	571				
	572				
	573				
48	574		OUT95: IN2 of LUT3_11 or Data of DFF15 Delay3 Input $\bar{}$ (or Counter3 nRST Input)		
	575				
	576			Matrix Input 0	GND
	577			Matrix Input 1	LUT2_0/DFF0 output
	578			Matrix Input 2	LUT2_1/DFF1 output
	579			Matrix Input 3	LUT2_2/DFF2 output
	580			Matrix Input 4	LUT2_3/PGen output
	581			Matrix Input 5	LUT3_0/DFF3 output
49	582	Matrix Input 6	LUT3_1/DFF4 output		
	583	Matrix Input 7	LUT3_2/DFF5 output		
	584	Matrix Input 8	LUT3_3/DFF6 output		
	585	Matrix Input 9	LUT3_4/DFF7 output		
	586	Matrix Input 10	LUT3_5/DFF8 output		
	587	Matrix Input 11	LUT3_6/DFF9 output		
	588	Matrix Input 12	LUT3_7/DFF10 output		
	589	Matrix Input 13	LUT3_8/DFF11 output		
	590	Matrix Input 14	CNT0 output		
	591	Matrix Input 15	MF0_LUT4/DFF_OUT		
4A	592	Matrix Input 16	CNT1 output		
	593	Matrix Input 17	MF1_LUT3/DFF_OUT		
	594	Matrix Input 18	CNT2 output		
	595	Matrix Input 19	MF2_LUT3/DFF_OUT		
	596	Matrix Input 20	CNT3 output		
	597	Matrix Input 21	MF3_LUT3/DFF_OUT		
	598	Matrix Input 22	CNT4 output		
	599	Matrix Input 23	MF4_LUT3/DFF_OUT		

**Auto AEC-Q100 Qualified GreenPAK Programmable  
Mixed-Signal Matrix**
**Table 57: Register Map (Continued)**

Address		Signal Function	Register Bit Definition
Byte	Register Bit		
4B	600	Matrix Input 24	CNT5 output
	601	Matrix Input 25	MF5_LUT3/DFF_OUT
	602	Matrix Input 26	CNT6 output
	603	Matrix Input 27	MF6_LUT3/DFF_OUT
	604	Matrix Input 28	CNT7 output
	605	Matrix Input 29	MF7_LUT3/DFF_OUT
	606	Matrix Input 30	LUT3_16/Ripple CNT/Pipe Delay_out0
	607	Matrix Input 31	Ripple CNT/Pipe Delay_out1
4C	608	Matrix Input 32	GPIO0 digital input or I2C_virtual_0 Input
	609	Matrix Input 33	GPIO1 digital input or I2C_virtual_1 Input
	610	Matrix Input 34	I2C_virtual_2 Input
	611	Matrix Input 35	I2C_virtual_3 Input
	612	Matrix Input 36	I2C_virtual_4 Input
	613	Matrix Input 37	I2C_virtual_5 Input
	614	Matrix Input 38	I2C_virtual_6 Input
	615	Matrix Input 39	I2C_virtual_7 Input
4D	616	Matrix Input 40	Ripple CNT_out2
	617	Matrix Input 41	LUT4_0/DFF12 output
	618	Matrix Input 42	Programmable Delay Edge Detect Output
	619	Matrix Input 43	Edge Detect Filter Output
	620	Matrix Input 44	GPIO Digital Input
	621	Matrix Input 45	GPIO2 Digital Input
	622	Matrix Input 46	Power Switch ON0, GPIO3 Digital Input
	623	Matrix Input 47	GPIO4 Digital Input
4E	624	Matrix Input 48	GPIO5 Digital Input
	625	Matrix Input 49	GPIO6 Digital Input
	626	Matrix Input 50	GPIO7 Digital Input
	627	Matrix Input 51	GPIO8 Digital Input
	628	Matrix Input 52	GPIO9 Digital Input
	629	Matrix Input 53	OSC0 output 0
	630	Matrix Input 54	OSC1 output 0
	631	Matrix Input 55	OSC2 output
4F	632	Matrix Input 56	ACMP0H Output (normal speed)
	633	Matrix Input 57	ACMP1H Output (normal speed)
	634	Matrix Input 58	ACMP2L Output (low speed)
	635	Matrix Input 59	ACMP3L output (low speed)
	636	Matrix Input 60	OSC0 output 1
	637	Matrix Input 61	OSC1 output 1
	638	Matrix Input 62	Matrix nRST
	639	Matrix Input 63	V <sub>DD</sub>

**Auto AEC-Q100 Qualified GreenPAK Programmable Mixed-Signal Matrix**
**Table 57: Register Map (Continued)**

Address		Signal Function	Register Bit Definition
Byte	Register Bit		
50	640	BG CHOP OFF	0: CHOP enable 1: chopper off
	641	BG Chopper clock test enable	1: enable
	642	Bandgap internal voltage output to IO enable	1: enable
	643	Bandgap power-down control	0: always on 1: power-down if no function enable it (ACMP, Vref, TS)
	644	ACMP1H external Vref0 source selection	0: from GPIO2 1: from GPO0
	645	ACMP2L external Vref1 source selection	0: from GPIO2 1: from GPO0
	646	ACMP3L external Vref1 source selection	0: from GPIO2 1: from GPO0
	647	ACMP3L wake sleep enable	1: enable 0: disable
51	648	VrefO0 register Power-On/Off	1: on 0: off
	649	VrefO0 power-down selection	0: come from register [648] 1: come from matrix out92
	650	VrefO1 register Power-On/Off	1: on 0: off
	651	ACMP0H hysteresis	00: 0 mV 01: 32 mV 10: 64 mV 11: 192 mV
	652		
	653	Reserved	
	654	ACMP0_H input buffer enable	1: enable
655	Reserved		
52	656	ACMP0H input tie to V <sub>DD</sub> enable	1: enable
	657	ACMP1_H positive input come from ACMP0_H's input mux output enable; 1:enable	
	658	Reserved	
	659	ACMP1H hysteresis	00: 0 mV 01: 32 mV 10: 64 mV 11: 192 mV
	660		
	661	ACMP1H input buffer enable	1: enable
	662	Reserved	
663	ACMP2L positive input come from ACMP0H's input mux output enable	1: enable	
53	664	ACMP2L positive input come from ACMP1H's input mux output enable	1: enable
	665	ACMP2L hysteresis	00: 0 mV 01: 32 mV 10: 64 mV 11: 192 mV
	666		
	667	Reserved	
	668	Reserved	
	669	ACMP3_L hysteresis	00: 0 mV 01: 32 mV 10: 64 mV 11: 192 mV
	670		
671	Reserved		

**Auto AEC-Q100 Qualified GreenPAK Programmable Mixed-Signal Matrix**
**Table 57: Register Map (Continued)**

Address		Signal Function	Register Bit Definition
Byte	Register Bit		
54	672	Reserved	
	673	ACMP3_L positive input come from ACMP2L's input mux output enable	1: enable
	674	Temp sensor register pdb control	0: Power-down 1: Power-On
	675	Temp sensor register pdb select	0: come from register 1: come from Matrix
	676	Temp sensor range select	0: range 1 (0.62V ~ 0.99V (TYP)) 1: range 2 (0.75V ~ 1.2V (TYP))
	677	Vref0 output OP	0: disable 1: enable
	678	Vref0 input selection	00: None
	679		01: ACMP0H Vref 10: ACMP1H Vref 11: temp sensor
55	680	Vref1 output OP	0: disable 1: enable
	681	Vref1 input selection	00: None
	682		01: ACMP2L Vref 10: ACMP3L Vref
	683	VBG fine tune selection	0000: 1.194, 0001:1.195, 0011:1.196, 0100:1.197,
	684		0101:1.198, 0110:1.199 0111:1.2, 1000:1.201, 1001:1.202,
	685		1010:1.203, 1011:1.204, 1100:1.205, 1101:1.206,
	686		1110:1.207, 1111:1.208
		687	ACMP0H Wake/Sleep enable
	688	ACMP1H Wake/Sleep enable	
56	689	ACMP Wake/Sleep time selection	0: short time 1: normal w/s
	690	ACMP0H 100 uA current source enable	
	691	Reserve for ACMP	
	692	Reserved	
	693	ACMP3L input come from Temp sensor output enable	
	694	VrefO1 power-down selection	0: come from register [650] 1: come from matrix OUT92
	695	ACMP2L wake sleep enable	0: disable 1: enable
	57	696	ACMP0H Gain divider
697			
698		ACMP0H Vref0	ACMP Vref select: 000000: 32mV ~ 111110: 2.016V/step = 32 mV 111111: External Vref
699			
700			
701			
702			
703			

**Auto AEC-Q100 Qualified GreenPAK Programmable Mixed-Signal Matrix**
**Table 57: Register Map (Continued)**

Address		Signal Function	Register Bit Definition
Byte	Register Bit		
58	704	ACMP1H Gain divider	ACMP gain divider select: 00: 1x 01:0.5x 10:0.33x 11:0.25x
	705		
	706	ACMP1H Vref0	ACMP Vref select: 000000: 32 mV ~ 1 11110: 2.016V/step = 32mV 111111: External Vref
	707		
	708		
	709		
	710		
711			
59	712	ACMP2L Gain divider	ACMP gain divider select: 00: 1x 01:0.5x 10:0.33x 11:0.25x
	713		
	714	ACMP2L Vref1	ACMP Vref select: 000000: 32 mV ~ 111110: 2.016V/step = 32mV 111111: External Vref
	715		
	716		
	717		
	718		
719			
5A	720	ACMP3L Gain divider	ACMP gain divider select: 00: 1x 01:0.5x 10:0.33x 11:0.25x
	721		
	722	ACMP3L Vref1	ACMP Vref select: 000000: 32 mV ~ 111110: 2.016V/step = 32mV 111112: External Vref
	723		
	724		
	725		
	726		
727			
<b>OSC1</b>			
5B	728	OSC1 turn on by register	when matrix output enable/pd control signal = 0: 0: auto on by delay cells 1: always on
	729	matrix power-down or on select	0: matrix down 1: matrix on
	730	external clock source enable	0: internal OSC1 1: external clock from GPIO2
	731	post divider ratio control OSC1	00: div 1 01: div 2 10: div 4 11: div 8
	732		
	733	matrix divider ratio control OSC1, OUT0	000: /1, 001:/2 , 010:/4, 011: /3, 100: /8, 101: /12, 110: /24, 111: /64
	734		
735			
5C	736	matrix out enable OSC1, OUT0	0: disable 1: enable
	737	Reserved	
	738	Reserved	
	739	Reserved	

**Auto AEC-Q100 Qualified GreenPAK Programmable Mixed-Signal Matrix**
**Table 57: Register Map (Continued)**

Address		Signal Function	Register Bit Definition
Byte	Register Bit		
<b>OSC2</b>			
5C	740	OSC2 turn on by register	when matrix output enable/pd control signal = 0: 0: auto on by delay cells 1: always on
	741	matrix power-down or on select	0: matrix down 1: matrix on
	742	external clock source enable	0: internal OSC2 1: external clock from GPIO8
	743	matrix out enable	0: disable 1: enable
5D	744	post divider ratio control OSC2	00: div 1 01: div 2 10: div 4 11: div 8
	745		
	746	matrix divider ratio control OSC2	000: /1, 001:/2 , 010:/4, 011: /3, 100: /8, 101: /12, 110: /24, 111: /64
	747		
	748		
749	startup delay with 100 ns	0: enable 1: disable	
<b>OSC0</b>			
5D	750	OSC0 turn on by register	when matrix output enable/pd control signal = 0: 0: auto on by delay cells 1: always on
	751	matrix power-down or on select	0: matrix down 1: matrix on
5E	752	external clock source enable	0: internal OSC0 1: external clock from GPIO
	753	matrix out enable OSC0, OUT0	0: disable 1: enable
	754	post divider ratio control OSC0	00: div 1 01: div 2 10: div 4 11: div 8
	755		
	756	matrix divider ratio control OSC0, OUT0	000: /1, 001:/2 , 010:/4, 011: /3, 100: /8, 101: /12, 110: /24, 111: /64
	757		
	758		
759	enable OSC0 output gating by wake_sleep signal (note: the wake_sleep clock is separated path, so it is not gated)	0: no gating 1: enable	
5F	760	matrix divider ratio control OSC1, OUT1	000: /1, 001:/2 , 010:/4, 011: /3, 100: /8, 101: /12, 110: /24, 111: /64
	761		
	762		
	763	2nd output to matrix enable OSC1	0: disable 1: enable
	764	matrix divider ratio control OSC0, OUT1	000: /1, 001:/2 , 010:/4, 011: /3, 100: /8, 101: /12, 110: /24, 111: /64
	765		
	766		
767	2nd output to matrix enable OSC0, OUT1	0: disable 1: enable	



**Auto AEC-Q100 Qualified GreenPAK Programmable Mixed-Signal Matrix**
**Table 57: Register Map (Continued)**

Address		Signal Function	Register Bit Definition		
Byte	Register Bit				
60	768	Reserved			
	769				
	770				
	771				
	772				
	773				
	774				
	775				
61	776	Reserved			
	777	Reserved			
	778	IO fast Pull-up/down enable	0: disable 1: enable		
<b>GPIO</b>					
61	779	input mode configuration	00: digital without Schmitt Trigger 01: digital with Schmitt Trigger 10: low voltage digital in 11: analog IO		
	780				
	781				
	782			Pull-up/down resistance selection	00: floating 01: 10K 10: 100K 11: 1M
	783			Pull-up/down selection	0: Pull-down 1: Pull-up
<b>GPIO0</b>					
62	784	input mode configuration	00: digital in without Schmitt Trigger 01: digital in with Schmitt Trigger (when register [2032] = 1) 10: low voltage digital in 11: Reserved		
	785				
	786			Pull-up/down resistance selection	00: floating 01: 10K 10: 100K 11: 1M
	787				
	788				
	789			I <sup>2</sup> C mode selection	0: I <sup>2</sup> C fast mode+ (3.2x drivability) 1: I <sup>2</sup> C standard/fast mode
	790			I/O selection	0: digital input 1: digital output (3.2x Open-Drain NMOS)
<b>GPIO1</b>					
62	791	input mode configuration	00: digital without Schmitt Trigger 01: digital in with Schmitt Trigger (when register [2032] = 1) 10: low voltage digital in 11: Reserved		
63	792				
	793			Pull-up/down resistance selection	00: floating 01: 10K 10: 100K 11: 1M
	794				
	795			Pull-up/down selection	0: Pull-down 1: Pull-up
	796			I/O selection	0: digital input 1: digital output (3.2x Open-Drain NMOS)
	797			Reserved	

**Auto AEC-Q100 Qualified GreenPAK Programmable Mixed-Signal Matrix**
**Table 57: Register Map (Continued)**

Address		Signal Function	Register Bit Definition	
Byte	Register Bit			
<b>GPIO2</b>				
63	798	input mode configuration	00: digital without Schmitt Trigger	
	799		01: digital with Schmitt Trigger 10: low voltage digital in 11: analog IO	
64	800	output mode configuration	00: Push-Pull 1x	
	801		01: Push-Pull 2x 10: 1x Open-Drain 11: 2x Open-Drain	
	802	Pull-up/down resistance selection	00: floating	
	803		01: 10K 10: 100K 11: 1M	
804	Pull-up/down selection	0: Pull-down 1: Pull-up		
<b>GPIO3</b>				
64	805	input mode configuration	00: digital without Schmitt Trigger	
	806		01: digital with Schmitt Trigger	
	807		10: low voltage digital in 11: analog IO	
65	808	output mode configuration	00: Push-Pull 1x 01: Push-Pull 2x 10: 1x Open-Drain 11: 2x Open-Drain	
65	809	Pull-up/down resistance selection	00: floating	
	810		01: 10K 10: 100K 11: 1M	
	811		Pull-up/down selection	0: Pull-down 1: Pull-up
<b>GPO0</b>				
65	812	Reserved		
	813			
	814		output mode configuration	00: Push-Pull 1x
	815			01: Push-Pull 2x 10: 1x Open-Drain 11: 2x Open-Drain
66	816	Pull-up/down resistance selection	00: floating	
	817		01: 10K 10: 100K 11: 1M	
	818	Pull-up/down selection	0: Pull-down 1: Pull-up	
	819	output enable	0: output disable (input mode) 1: output enable	
	820	4x drive	0: disable 1: enable	
<b>GPIO4</b>				

**Auto AEC-Q100 Qualified GreenPAK Programmable Mixed-Signal Matrix**
**Table 57: Register Map (Continued)**

Address		Signal Function	Register Bit Definition	
Byte	Register Bit			
66	821	input mode configuration	00: digital without Schmitt Trigger	
	822		01: digital with Schmitt Trigger	
	823		10: low voltage digital in 11: analog IO	
67	824	output mode configuration	00: Push-Pull 1x 01: Push-Pull 2x 10: 1x Open-Drain 11: 2x Open-Drain	
	825		Pull-up/down resistance selection	00: floating 01: 10K 10: 100K 11: 1M
	826	Pull-up/down selection		0: Pull-down 1: Pull-up
	827			0: disable 1: enable
	828	4x drive	0: disable 1: enable	
<b>GPIO5</b>				
67	829	input mode configuration	00: digital without Schmitt Trigger	
	830		01: digital with Schmitt Trigger	
	831		10: low voltage digital in 11: analog IO	
68	832	output mode configuration	00: Push-Pull 1x 01: Push-Pull 2x 10: 1x Open-Drain 11: 2x Open-Drain	
	833		Pull-up/down resistance selection	00: floating 01: 10K 10: 100K 11: 1M
	834	Pull-up/down selection		0: Pull-down 1: Pull-up
	835			0: Pull-down 1: Pull-up
<b>GPIO6</b>				
68	836	input mode configuration	00: digital without Schmitt Trigger	
	837		01: digital with Schmitt Trigger	
	838		10: low voltage digital in 11: analog IO	
	839	output mode configuration	00: Push-Pull 1x 01: Push-Pull 2x 10: 1x Open-Drain 11: 2x Open-Drain	
69	840	Pull-up/down resistance selection	00: floating 01: 10K 10: 100K 11: 1M	
	841		Pull-up/down selection	0: Pull-down 1: Pull-up
	842	0: Pull-down 1: Pull-up		
<b>GPIO7</b>				

**Auto AEC-Q100 Qualified GreenPAK Programmable Mixed-Signal Matrix**
**Table 57: Register Map (Continued)**

Address		Signal Function	Register Bit Definition	
Byte	Register Bit			
69	843	input mode configuration	00: digital without Schmitt Trigger	
	844		01: digital with Schmitt Trigger	
	845	output mode configuration	10: low voltage digital in	
	846		11: analog IO	
	847		00: Push-Pull 1x	
6A	848	Pull-up/down resistance selection	01: Push-Pull 2x	
	849	Pull-up/down selection	10: 1x Open-Drain	
<b>GPIO8</b>				
6A	850	input mode configuration	11: 2x Open-Drain	
	851		00: floating	
	852	output mode configuration	01: 10K	
	853		10: 100K	
	854		11: 1M	
	6B	855	Pull-up/down resistance selection	0: Pull-down
856		Pull-up/down selection	1: Pull-up	
<b>GPIO9</b>				
6B	857	input mode configuration	00: digital without Schmitt Trigger	
	858		01: digital with Schmitt Trigger	
	859	output mode configuration	10: low voltage digital in	
	860		11: analog IO	
	861		00: Push-Pull 1x	
	6C	862	Pull-up/down resistance selection	01: Push-Pull 2x
		863	Pull-up/down selection	10: 1x Open-Drain
6C	864	Reserved	11: 2x Open-Drain	
	865	Reserved	00: floating	
	866	Reserved	01: 10K	
	867	Reserved	10: 100K	
	868	Reserved	11: 1M	
	869	Reserved	0: Pull-down	
	870	Reserved	1: Pull-up	
	871	Reserved		

# SLG46855-A

## Auto AEC-Q100 Qualified GreenPAK Programmable Mixed-Signal Matrix

**Table 57: Register Map (Continued)**

Address		Signal Function	Register Bit Definition
Byte	Register Bit		
6D	872	Reserved	
	873	Reserved	
	874	Reserved	
	875	Reserved	
	876	Reserved	
	877	Reserved	
	878	Reserved	
	879	Reserved	
6E	880	Reserved	
	881	Reserved	
	882	Reserved	
	883	Reserved	
	884	Reserved	
	885	Reserved	
	886	Reserved	
	887	Reserved	
6F	888	Reserved	
	889	Reserved	
	890	Reserved	
	891	Reserved	
	892	Reserved	
	893	Reserved	
	894	Reserved	
	895	Reserved	
70	896	Reserved	
	897	Reserved	
	898	Reserved	
	899	Reserved	
	900	Reserved	
	901	Reserved	
	902	Reserved	
	903	Reserved	
71	904	Reserved	
	905	Reserved	
	906	Reserved	
	907	Reserved	
	908	Reserved	
	909	Reserved	
	910	Reserved	
	911	Reserved	
72	912	Reserved	
	913	Reserved	
	914	Reserved	
	915	Reserved	
	916	Reserved	
	917	Reserved	
	918	Reserved	
	919	Reserved	

# SLG46855-A

## Auto AEC-Q100 Qualified GreenPAK Programmable Mixed-Signal Matrix

**Table 57: Register Map (Continued)**

Address		Signal Function	Register Bit Definition
Byte	Register Bit		
73	920	Reserved	
	921	Reserved	
	922	Reserved	
	923	Reserved	
	924	Reserved	
	925	Reserved	
	926	Reserved	
	927	Reserved	
74	928	Reserved	
	929	Reserved	
	930	Reserved	
	931	Reserved	
	932	Reserved	
	933	Reserved	
	934	Reserved	
	935	Reserved	
75	936	Reserved	
	937	Reserved	
	938	Reserved	
	939	Reserved	
	940	Reserved	
	941	Reserved	
	942	Reserved	
	943	Reserved	
76	944	Reserved	
	945	Reserved	
	946	Reserved	
	947	Reserved	
	948	Reserved	
	949	Reserved	
	950	Reserved	
	951	Reserved	
77	952	Reserved	
	953	Reserved	
	954	Reserved	
	955	Reserved	
	956	Reserved	
	957	Reserved	
	958	Reserved	
	959	Reserved	
78	960	Reserved	
	961	Reserved	
	962	Reserved	
	963	Reserved	
	964	Reserved	
	965	Reserved	
	966	Reserved	
	967	Reserved	

# SLG46855-A

## Auto AEC-Q100 Qualified GreenPAK Programmable Mixed-Signal Matrix

**Table 57: Register Map (Continued)**

Address		Signal Function	Register Bit Definition
Byte	Register Bit		
79	968	Reserved	
	969	Reserved	
	970	Reserved	
	971	Reserved	
	972	Reserved	
	973	Reserved	
	974	Reserved	
	975	Reserved	
7A	976	Reserved	
	977	Reserved	
	978	Reserved	
	979	Reserved	
	980	Reserved	
	981	Reserved	
	982	Reserved	
	983	Reserved	
7B	984	Reserved	
	985	Reserved	
	986	Reserved	
	987	Reserved	
	988	Reserved	
	989	Reserved	
	990	Reserved	
	991	Reserved	
7C	992	Reserved	
	993	Reserved	
	994	Reserved	
	995	Reserved	
	996	Reserved	
	997	Reserved	
	998	Reserved	
	999	Reserved	
7D	1000	Reserved	
	1001	Reserved	
	1002	Reserved	
	1003	Reserved	
	1004	Reserved	
	1005	Reserved	
	1006	Reserved	
	1007	Reserved	
7E	1008	Reserved	
	1009	Reserved	
	1010	Reserved	
	1011	Reserved	
	1012	Reserved	
	1013	Reserved	
	1014	Reserved	
	1015	Reserved	

**Auto AEC-Q100 Qualified GreenPAK Programmable Mixed-Signal Matrix**
**Table 57: Register Map (Continued)**

Address		Signal Function	Register Bit Definition
Byte	Register Bit		
7F	1016	Reserved	
	1017	Reserved	
	1018	Reserved	
	1019	Reserved	
	1020	Reserved	
	1021	Reserved	
	1022	Reserved	
	1023	Reserved	
80	1030:1024	Single 4-bit LUT	0000000: Matrix A - In3; Matrix B - In2; Matrix C - In1; Matrix D - In0 (DLY_IN - LOW)
		Single DFF w RST and SET	0010000: Matrix A - D; Matrix B - nSET; Matrix C - nRST; Matrix D - CLK (DLY_IN - LOW)
		Single CNT/DLY	0000001: Matrix A - UP (CNT); Matrix B - KEEP (CNT); Matrix C - EXT_CLK (CNT); Matrix D - DLY_IN (CNT) (DLY_OUT connected to LUT/DFF)
		CNT/DLY → LUT	0000010: Matrix A - DLY_IN; Matrix B - In2; Matrix C - In1; Matrix D - In0 (DLY_OUT connected to In3)
		CNT/DLY → DFF	0010010: Matrix A - DLY_IN; Matrix B - nSET; Matrix C - nRST; Matrix D - CLK (DLY_OUT connected to D)
		CNT/DLY → LUT	0100010: Matrix A - DLY_IN; Matrix B - EXT_CLK (CNT); Matrix C - In1; Matrix D - In0 (DLY_OUT connected to In3; In2 - LOW)
		CNT/DLY → DFF	0110010: Matrix A - DLY_IN; Matrix B - EXT_CLK (CNT); Matrix C - nRST; Matrix D - CLK (DLY_OUT connected to D; nSET - HIGH)
		CNT/DLY → LUT	1000010: Matrix A - DLY_IN; Matrix B - In2; Matrix C - EXT_CLK (CNT); Matrix D - In0 (DLY_OUT connected to In3; In1 - LOW)
		CNT/DLY → DFF	1010010: Matrix A - DLY_IN; Matrix B - nSET; Matrix C - EXT_CLK (CNT); Matrix D - CLK (DLY_OUT connected to D; nRST - HIGH)
		CNT/DLY → LUT	0000110: Matrix A - In3; Matrix B - DLY_IN; Matrix C - In1; Matrix D - In0 (DLY_OUT connected to In2)
		CNT/DLY → DFF	0010110: Matrix A - D; Matrix B - DLY_IN; Matrix C - nRST; Matrix D - CLK (DLY_OUT connected to nSET)
CNT/DLY → LUT	1000110: Matrix A - In3; Matrix B - DLY_IN; Matrix C - EXT_CLK (CNT); Matrix D - In0 (DLY_OUT connected to In2; In1 - LOW)		



**Auto AEC-Q100 Qualified GreenPAK Programmable Mixed-Signal Matrix**
**Table 57: Register Map (Continued)**

Address		Signal Function	Register Bit Definition
Byte	Register Bit		
80	1030:1024	CNT/DLY → DFF	1010110: Matrix A - D; Matrix B - DLY_IN; Matrix C - EXT_CLK (CNT); Matrix D - CLK (DLY_OUT connected to nSET; nRST - HIGH)
		CNT/DLY → LUT	0001010: Matrix A - In3; Matrix B - In2; Matrix C - DLY_IN; Matrix D - In0 (DLY_OUT connected to In1)
		CNT/DLY → DFF	0011010: Matrix A - D; Matrix B - nSET; Matrix C - DLY_IN; Matrix D - CLK (DLY_OUT connected to nRST)
		CNT/DLY → LUT	0101010: Matrix A - In3; Matrix B - EXT_CLK (CNT); Matrix C - DLY_IN; Matrix D - In0 (DLY_OUT connected to In1; In2 - LOW)
		CNT/DLY → DFF	0111010: Matrix A - D; Matrix B - EXT_CLK (CNT); Matrix C - DLY_IN; Matrix D - CLK (DLY_OUT connected to nRST; nSET - HIGH)
		CNT/DLY → LUT	0001110: Matrix A - In3; Matrix B - In2; Matrix C - In1; Matrix D - DLY_IN (DLY_OUT connected to In0)
		CNT/DLY → DFF	0011110: Matrix A - D; Matrix B - nSET; Matrix C - nRST; Matrix D - DLY_IN (DLY_OUT connected to CLK)
		CNT/DLY → LUT	0101110: Matrix A - In3; Matrix B - EXT_CLK (CNT); Matrix C - In1; Matrix D - DLY_IN (DLY_OUT connected to In0; In2 - LOW)
		CNT/DLY → DFF	0111110: Matrix A - D; Matrix B - EXT_CLK (CNT); Matrix C - nRST; Matrix D - DLY_IN (DLY_OUT connected to CLK; nSET - HIGH)
		CNT/DLY → LUT	1001110: Matrix A - In3; Matrix B - In2; Matrix C - EXT_CLK (CNT); Matrix D - DLY_IN (DLY_OUT connected to In0; In1 - LOW)
		CNT/DLY → DFF	1011110: Matrix A - D; Matrix B - nSET; Matrix C - EXT_CLK (CNT); Matrix D - DLY_IN (DLY_OUT connected to CLK; nRST - HIGH)
		LUT → CNT/DLY	0000011: Matrix A - In3; Matrix B - In2; Matrix C - In1; Matrix D - In0 (LUT_OUT connected to DLY_IN)
		DFF → CNT/DLY	0010011: Matrix A - D; Matrix B - nSET; Matrix C - nRST; Matrix D - CLK (DFF_OUT connected to DLY_IN)
		LUT → CNT/DLY	0100011: Matrix A - In3; Matrix B - EXT_CLK (CNT); Matrix C - In1; Matrix D - In0 (LUT_OUT connected to DLY_IN; In2 - LOW)

**Auto AEC-Q100 Qualified GreenPAK Programmable Mixed-Signal Matrix**
**Table 57: Register Map (Continued)**

Address		Signal Function	Register Bit Definition
Byte	Register Bit		
80	1030:1024	DFF → CNT/DLY	0110011: Matrix A - D; Matrix B - EXT_CLK (CNT); Matrix C - nRST; Matrix D - CLK (DFF_OUT connected to DLY_IN; nSET - HIGH)
		LUT → CNT/DLY	1000011: Matrix A - In3; Matrix B - In2; Matrix C - EXT_CLK (CNT); Matrix D - In0 (LUT_OUT connected to DLY_IN; In1 - LOW)
		DFF → CNT/DLY	1010011: Matrix A - D; Matrix B - nSET; Matrix C - EXT_CLK (CNT); Matrix D - CLK (DFF_OUT connected to DLY_IN; nRST - HIGH)
	1031		00: DLY 01: one shot 10: frequency det 11: CNT register [1040] = 0
81	1032	DLY/CNT0 Mode Selection	00: both edge 01: falling edge 10: rising edge 11: High Level Reset (only in CNT mode)
	1033		
	1034	DLY/CNT0 edge Mode Selection	
	1035	DLY/CNT0 Clock Source Select	Clock source sel[3:0] 0000: 25M(OSC2); 0001: 25M/4; 0010: 2M(OSC1); 0011: 2M/8; 0100: 2M/64; 0101: 2M/512; 0110: 2K(OSC0); 0111: 2K/8; 1000: 2K/64; 1001: 2K/512; 1010: 2K/4096; 1011: 2K/32768; 1100: 2 K/262144; 1101: CNT7_END; 1110: External; 1111: Not used
	1036		
	1037		
	1038		
	1039	FSM0 SET/RST Selection	0: Reset to 0 1: Set to data
82	1040	CNT0 DLY EDET FUNCTION Selection	0: normal 1: DLY function edge detection (registers [1032:1031] = 00)
	1041	UP signal SYNC selection	0: bypass 1: after two DFF
	1042	Keep signal SYNC selection	0: bypass 1: after two DFF
	1043	CNT0 initial value selection	00: bypass the initial 01: initial 0 10: initial 1 11: initial 1
	1044		
	1045	Wake sleep power-down state selection	0: low 1: high
	1046	wake sleep mode selection	0: Default Mode 1: Wake Sleep Mode (registers [1032:1031] = 11)
	1047	CNT0 output pol selection	0: Default Output 1: Inverted Output

**Auto AEC-Q100 Qualified GreenPAK Programmable Mixed-Signal Matrix**
**Table 57: Register Map (Continued)**

Address		Signal Function	Register Bit Definition
Byte	Register Bit		
83	1048	CNT0 CNT mode SYNC selection	0: bypass 1: after two DFF
	1053:1049	Single 3-bit LUT	00000: Matrix A - In2; Matrix B - In1; Matrix C - In0 (DLY_IN - LOW)
		Single DFF w RST and SET	10000: Matrix A - D; Matrix B - nSET/nRST; Matrix C - CLK (DLY_IN - LOW)
		Single CNT/DLY	00001: Matrix A - DLY_IN (CNT); Matrix B - EXT_CLK (CNT); Matrix C - NC (DLY_OUT connected to LUT/DFF)
		CNT/DLY → LUT	00010: Matrix A - DLY_IN; Matrix B - In1; Matrix C - In0 (DLY_OUT connected to In2)
		CNT/DLY → DFF	10010: Matrix A - DLY_IN; Matrix B - nSET/nRST; Matrix C - CLK (DLY_OUT connected to D)
		CNT/DLY → LUT	00110: Matrix A - In2; Matrix B - DLY_IN; Matrix C - In0 (DLY_OUT connected to In1)
		CNT/DLY → DFF	10110: Matrix A - D; Matrix B - DLY_IN; Matrix C - CLK (DLY_OUT connected to nSET/nRST)
		CNT/DLY → LUT	01010: Matrix A - In2; Matrix B - In1; Matrix C - DLY_IN (DLY_OUT connected to In0)
		CNT/DLY → DFF	11010: Matrix A - D; Matrix B - nSET/nRST; Matrix C - DLY_IN (DLY_OUT connected to CLK)
		LUT → CNT/DLY	00011: Matrix A - In2; Matrix B - In1; Matrix C - In0 (LUT_OUT connected to DLY_IN)
	DFF → CNT/DLY	10011: Matrix A - D; Matrix B - nSET/nRST; Matrix C - CLK (DFF_OUT connected to DLY_IN)	
	1054	CNT1 function and edge mode selection	0000: both edge Delay; 0001: falling edge delay; 0010: rising edge delay; 0011: both edge One Shot; 0100: falling edge One Shot; 0101: rising edge One Shot; 0110: both edge freq detect; 0111: falling edge freq detect; 1000: rising edge freq detect; 1001: both edge detect; 1010: falling edge detect; 1011: rising edge detect; 1100: both edge reset CNT; 1101: falling edge reset CNT; 1110: rising edge reset CNT; 1111: high level reset CNT
	1055		
1056			
84	1057		
	1058		
	1059	CNT1 initial value selection	00: bypass the initial 01: initial 0 10: initial 1 11: initial 1

**Auto AEC-Q100 Qualified GreenPAK Programmable Mixed-Signal Matrix**
**Table 57: Register Map (Continued)**

Address		Signal Function	Register Bit Definition	
Byte	Register Bit			
84	1060	DLY/CNT1 Clock Source Select	Clock source sel[3:0] 0000: 25M(OSC2); 0001: 25M/4; 0010: 2M(OSC1); 0011: 2M/8; 0100: 2M/64; 0101: 2M/512; 0110: 2K(OSC0); 0111: 2K/8; 1000: 2K/64; 1001: 2K/512; 1010: 2K/4096; 1011: 2K/32768; 1100: 2K/262144; 1101: CNT0_END; 1110: External; 1111: Not used	
	1061			
	1062			
	1063			
85	1064	CNT1 output pol selection	0: Default Output 1: Inverted Output	
	1065	CNT1 CNT mode SYNC selection	0: bypass 1: after two DFF	
	1066	CNT1 DLY EDET FUNCTION Selection	0: normal 1: DLY function edge detection (registers[1057:1054]=0000/0001/0010)	
	1071:1067		Single 3-bit LUT	00000: Matrix A - In2; Matrix B - In1; Matrix C - In0 (DLY_IN - LOW)
			Single DFF w RST and SET	10000: Matrix A - D; Matrix B - nSET/nRST; Matrix C - CLK (DLY_IN - LOW)
			Single CNT/DLY	00001: Matrix A - DLY_IN (CNT); Matrix B - EXT_CLK (CNT); Matrix C - NC (DLY_OUT connected to LUT/DFF)
			CNT/DLY → LUT	00010: Matrix A - DLY_IN; Matrix B - In1; Matrix C - In0 (DLY_OUT connected to In2)
			CNT/DLY → DFF	10010: Matrix A - DLY_IN; Matrix B - nSET/nRST; Matrix C - CLK (DLY_OUT connected to D)
			CNT/DLY → LUT	00110: Matrix A - In2; Matrix B - DLY_IN; Matrix C - In0 (DLY_OUT connected to In1)
			CNT/DLY → DFF	10110: Matrix A - D; Matrix B - DLY_IN; Matrix C - CLK (DLY_OUT connected to nSET/nRST)
			CNT/DLY → LUT	01010: Matrix A - In2; Matrix B - In1; Matrix C - DLY_IN (DLY_OUT connected to In0)
			CNT/DLY → DFF	11010: Matrix A - D; Matrix B - nSET/nRST; Matrix C - DLY_IN (DLY_OUT connected to CLK)
			LUT → CNT/DLY	00011: Matrix A - In2; Matrix B - In1; Matrix C - In0 (LUT_OUT connected to DLY_IN)
	DFF → CNT/DLY	10011: Matrix A - D; Matrix B - nSET/nRST; Matrix C - CLK (DFF_OUT connected to DLY_IN)		

**Auto AEC-Q100 Qualified GreenPAK Programmable Mixed-Signal Matrix**
**Table 57: Register Map (Continued)**

Address		Signal Function	Register Bit Definition
Byte	Register Bit		
86	1072	CNT2 initial value selection	00: bypass the initial 01: initial 0 10: initial 1 11: initial 1
	1073		
	1074	CNT2 function and edge mode selection	0000: both edge Delay; 0001: falling edge delay; 0010: rising edge delay; 0011: both edge One Shot; 0100: falling edge One Shot; 0101: rising edge One Shot; 0110: both edge freq detect; 0111: falling edge freq detect; 1000: rising edge freq detect; 1001: both edge detect; 1010: falling edge detect; 1011: rising edge detect; 1100: both edge reset CNT; 1101: falling edge reset CNT; 1110: rising edge reset CNT; 1111: high level reset CNT
	1075		
	1076		
	1077		
	1078	DLY/CNT2 Clock Source Select	Clock source sel[3:0] 0000: 25M(OSC2); 0001: 25M/4; 0010: 2M(OSC1); 0011: 2M/8; 0100: 2M/64; 0101: 2M/512; 0110: 2K(OSC0); 0111: 2K/8; 1000: 2K/64; 1001: 2K/512; 1010: 2K/4096; 1011: 2K/32768; 1100: 2K/262144; 1101: CNT1_END; 1110: External; 1111: Not used
1079			
1080			
87	1081		
	1082	CNT2 output pol selection	0: Default Output, 1: Inverted Output
	1083	CNT2 CNT mode SYNC selection	0: bypass; 1: after two DFF
	1084	CNT2 DLY EDET FUNCTION Selection	0: normal; 1: DLY function edge detection(registers[1077:1074] = 0000/0001/0010)
	1085	CNT3 initial value selection	00:bypass the initial; 01: initial 0; 10: initial 1; 11: initial 1
	1086		
	1087	Multi3 register configure	refer to byte 88
88	1088	CNT3 function and edge mode selection	0000: both edge Delay; 0001: falling edge delay; 0010: rising edge delay; 0011: both edge One Shot; 0100: falling edge One Shot; 0101: rising edge One Shot; 0110: both edge freq detect; 0111: falling edge freq detect; 1000: rising edge freq detect; 1001: both edge detect; 1010: falling edge detect; 1011: rising edge detect; 1100: both edge reset CNT; 1101: falling edge reset CNT; 1110: rising edge reset CNT; 1111: high level reset CNT
	1089		
	1090		
	1091		

**Auto AEC-Q100 Qualified GreenPAK Programmable Mixed-Signal Matrix**
**Table 57: Register Map (Continued)**

Address		Signal Function	Register Bit Definition
Byte	Register Bit		
88	1087, 1093:1092, 1095:1094	Single 3-bit LUT	00000: Matrix A - In2; Matrix B - In1; Matrix C - In0 (DLY_IN - LOW)
		Single DFF w RST and SET	10000: Matrix A - D; Matrix B - nSET/nRST; Matrix C - CLK (DLY_IN - LOW)
		Single CNT/DLY	00001: Matrix A - DLY_IN (CNT); Matrix B - EXT_CLK (CNT); Matrix C - NC (DLY_OUT connected to LUT/DFF)
		CNT/DLY → LUT	00010: Matrix A - DLY_IN; Matrix B - In1; Matrix C - In0 (DLY_OUT connected to In2)
		CNT/DLY → DFF	10010: Matrix A - DLY_IN; Matrix B - nSET/nRST; Matrix C - CLK (DLY_OUT connected to D)
		CNT/DLY → LUT	00110: Matrix A - In2; Matrix B - DLY_IN; Matrix C - In0 (DLY_OUT connected to In1)
		CNT/DLY → DFF	10110: Matrix A - D; Matrix B - DLY_IN; Matrix C - CLK (DLY_OUT connected to nSET/nRST)
		CNT/DLY → LUT	01010: Matrix A - In2; Matrix B - In1; Matrix C - DLY_IN (DLY_OUT connected to In0)
		CNT/DLY → DFF	11010: Matrix A - D; Matrix B - nSET/nRST; Matrix C - DLY_IN (DLY_OUT connected to CLK)
		LUT → CNT/DLY	00011: Matrix A - In2; Matrix B - In1; Matrix C - In0 (LUT_OUT connected to DLY_IN)
		DFF → CNT/DLY	10011: Matrix A - D; Matrix B - nSET/nRST; Matrix C - CLK (DFF_OUT connected to DLY_IN)
89	1096	DLY/CNT3 Clock Source Select	Clock source sel[3:0]
	1097		0000: 25M(OSC2); 0001: 25M/4;
	1098		0010: 2M(OSC1); 0011: 2M/8;
	1099		0100: 2M/64; 0101: 2M/512;
			0110: 2K(OSC0); 0111: 2K/8; 1000: 2K/64; 1001: 2K/512; 1010: 2K/4096; 1011: 2K/32768; 1100: 2K/262144; 1101: CNT2_END; 1110: External; 1111: Not used
1100	CNT3 output pol selection	0: Default Output 1: Inverted Output	
1101	CNT3 CNT mode SYNC selection	0: bypass 1: after two DFF	
1102	CNT3 DLY EDET FUNCTION Selection	0: normal 1: DLY function edge detection (registers[1091:1088]=0000/0001/0010)	
1103	CNT4 CNT mode SYNC selection	0: bypass 1: after two DFF	

**Auto AEC-Q100 Qualified GreenPAK Programmable Mixed-Signal Matrix**
**Table 57: Register Map (Continued)**

Address		Signal Function	Register Bit Definition	
Byte	Register Bit			
8A	1104	CNT4 initial value selection	00: bypass the initial 01: initial 0 10: initial 1 11: initial 1	
	1105			
	1106	CNT4 DLY EDET FUNCTION Selection	0: normal 1: DLY function edge detection (registers[1119:1116]=0000/0001/0010)	
	1111:1107		Single 3-bit LUT	00000: Matrix A - In2; Matrix B - In1; Matrix C - In0 (DLY_IN - LOW)
			Single DFF w RST and SET	10000: Matrix A - D; Matrix B - nSET/nRST; Matrix C - CLK (DLY_IN - LOW)
			Single CNT/DLY	00001: Matrix A - DLY_IN (CNT); Matrix B - EXT_CLK (CNT); Matrix C - NC (DLY_OUT connected to LUT/DFF)
			CNT/DLY → LUT	00010: Matrix A - DLY_IN; Matrix B - In1; Matrix C - In0 (DLY_OUT connected to In2)
			CNT/DLY → DFF	10010: Matrix A - DLY_IN; Matrix B - nSET/nRST; Matrix C - CLK (DLY_OUT connected to D)
			CNT/DLY → LUT	00110: Matrix A - In2; Matrix B - DLY_IN; Matrix C - In0 (DLY_OUT connected to In1)
			CNT/DLY → DFF	10110: Matrix A - D; Matrix B - DLY_IN; Matrix C - CLK (DLY_OUT connected to nSET/nRST)
			CNT/DLY → LUT	01010: Matrix A - In2; Matrix B - In1; Matrix C - DLY_IN (DLY_OUT connected to In0)
			CNT/DLY → DFF	11010: Matrix A - D; Matrix B - nSET/nRST; Matrix C - DLY_IN (DLY_OUT connected to CLK)
			LUT → CNT/DLY	00011: Matrix A - In2; Matrix B - In1; Matrix C - In0 (LUT_OUT connected to DLY_IN)
		DFF → CNT/DLY	10011: Matrix A - D; Matrix B - nSET/nRST; Matrix C - CLK (DFF_OUT connected to DLY_IN)	
8B	1112	DLY/CNT4 Clock Source Select	Clock source sel[3:0] 0000: 25M(OSC2); 0001: 25M/4; 0010: 2M(OSC1); 0011: 2M/8; 0100: 2M/64; 0101: 2M/512; 0110: 2K(OSC0); 0111: 2K/8; 1000: 2K/64; 1001: 2K/512; 1010: 2K/4096; 1011: 2K/32768; 1100: 2K/262144; 1101: CNT3_END; 1110: External; 1111: Not used	
	1113			
	1114			
	1115			

**Auto AEC-Q100 Qualified GreenPAK Programmable Mixed-Signal Matrix**
**Table 57: Register Map (Continued)**

Address		Signal Function	Register Bit Definition
Byte	Register Bit		
8B	1116	CNT4 function and edge mode selection	0000: both edge Delay; 0001: falling edge delay; 0010: rising edge delay; 0011: both edge One Shot; 0100: falling edge One Shot; 0101: rising edge One Shot; 0110: both edge freq detect; 0111: falling edge freq detect; 1000: rising edge freq detect; 1001: both edge detect; 1010: falling edge detect; 1011: rising edge detect; 1100: both edge reset CNT; 1101: falling edge reset CNT; 1110: rising edge reset CNT; 1111: high level reset CNT
	1117		
	1118		
	1119		
8C	1120	CNT4 output pol selection	0: Default Output 1: Inverted Output
	1121	CNT5 function and edge mode selection	0000: both edge Delay; 0001: falling edge delay; 0010: rising edge delay; 0011: both edge One Shot; 0100: falling edge One Shot; 0101: rising edge One Shot; 0110: both edge freq detect; 0111: falling edge freq detect; 1000: rising edge freq detect; 1001: both edge detect; 1010: falling edge detect; 1011: rising edge detect; 1100: both edge reset CNT; 1101: falling edge reset CNT; 1110: rising edge reset CNT; 1111: high level reset CNT
	1122		
	1123		
	1124		
	1125	CNT5 output pol selection	0: Default Output 1: Inverted Output
	1134, 1127:1126, 1133:1132	Single 3-bit LUT	00000: Matrix A - In2; Matrix B - In1; Matrix C - In0 (DLY_IN - LOW)
		Single DFF w RST and SET	10000: Matrix A - D; Matrix B - nSET/nRST; Matrix C - CLK (DLY_IN - LOW)
		Single CNT/DLY	00001: Matrix A - DLY_IN (CNT); Matrix B - EXT_CLK (CNT); Matrix C - NC (DLY_OUT connected to LUT/DFF)
		CNT/DLY → LUT	00010: Matrix A - DLY_IN; Matrix B - In1; Matrix C - In0 (DLY_OUT connected to In2)
		CNT/DLY → DFF	10010: Matrix A - DLY_IN; Matrix B - nSET/nRST; Matrix C - CLK (DLY_OUT connected to D)
		CNT/DLY → LUT	00110: Matrix A - In2; Matrix B - DLY_IN; Matrix C - In0 (DLY_OUT connected to In1)
		CNT/DLY → DFF	10110: Matrix A - D; Matrix B - DLY_IN; Matrix C - CLK (DLY_OUT connected to nSET/nRST)
CNT/DLY → LUT	01010: Matrix A - In2; Matrix B - In1; Matrix C - DLY_IN (DLY_OUT connected to In0)		



**Auto AEC-Q100 Qualified GreenPAK Programmable Mixed-Signal Matrix**
**Table 57: Register Map (Continued)**

Address		Signal Function	Register Bit Definition
Byte	Register Bit		
8C	1134, 1127:1126, 1133:1132	CNT/DLY → DFF	11010: Matrix A - D; Matrix B - nSET/nRST; Matrix C - DLY_IN (DLY_OUT connected to CLK)
		LUT → CNT/DLY	00011: Matrix A - In2; Matrix B - In1; Matrix C - In0 (LUT_OUT connected to DLY_IN)
		DFF → CNT/DLY	10011: Matrix A - D; Matrix B - nSET/nRST; Matrix C - CLK (DFF_OUT connected to DLY_IN)
8D	1128	DLY/CNT5 Clock Source Select	Clock source sel[3:0] 0000: 25M(OSC2); 0001: 25M/4; 0010: 2M(OSC1); 0011:2M/8; 0100: 2M/64; 0101: 2M/512; 0110:2K(OSC0); 0111: 2K/8; 1000:2K/64; 1001: 2K/512; 1010: 2K/4096; 1011:2K/32768; 1100: 2K/262144; 1101: CNT4_END; 1110: External; 1111: Not used
	1129		
	1130		
	1131		
	1135	CNT5 DLY EDET FUNCTION Selection	0: normal; 1: DLY function edge detection (registers[1124:1121]=0000/0001/0010)
8E	1136	CNT5 CNT mode SYNC selection	0: bypass; 1: after two DFF
	1137	CNT5 initial value selection	00: bypass the initial 01: initial 0 10: initial 1 11: initial 1
	1138		
	1139	CNT6 function and edge mode selection	0000: both edge Delay; 0001: falling edge delay; 0010: rising edge delay; 0011: both edge One Shot; 0100: falling edge One Shot; 0101: rising edge One Shot; 0110: both edge freq detect; 0111: falling edge freq detect; 1000: rising edge freq detect; 1001: both edge detect; 1010: falling edge detect; 1011: rising edge detect; 1100: both edge reset CNT; 1101: falling edge reset CNT; 1110: rising edge reset CNT; 1111: high level reset CNT
	1140		
	1141		
	1142		
	1143	CNT6 output pol selection	0: Default Output 1: Inverted Output

**Auto AEC-Q100 Qualified GreenPAK Programmable Mixed-Signal Matrix**
**Table 57: Register Map (Continued)**

Address		Signal Function	Register Bit Definition		
Byte	Register Bit				
8F	1144	DLY/CNT6 Clock Source Select	Clock source sel[3:0] 0000: 25M(OSC2); 0001: 25M/4; 0010: 2M(OSC1); 0011: 2M/8; 0100: 2M/64; 0101: 2M/512; 0110: 2K(OSC0); 0111: 2K/8; 1000: 2K/64; 1001: 2K/512; 1010: 2K/4096; 1011: 2K/32768; 1100: 2K/262144; 1101: CNT5_END; 1110: External; 1111: Not used		
	1145				
	1146				
	1147				
	1152, 1149:1148, 1151:1150			Single 3-bit LUT	00000: Matrix A - In2; Matrix B - In1; Matrix C - In0 (DLY_IN - LOW)
				Single DFF w RST and SET	10000: Matrix A - D; Matrix B - nSET/nRST; Matrix C - CLK (DLY_IN - LOW)
				Single CNT/DLY	00001: Matrix A - DLY_IN (CNT); Matrix B - EXT_CLK (CNT); Matrix C - NC (DLY_OUT connected to LUT/DFF)
				CNT/DLY → LUT	00010: Matrix A - DLY_IN; Matrix B - In1; Matrix C - In0 (DLY_OUT connected to In2)
				CNT/DLY → DFF	10010: Matrix A - DLY_IN; Matrix B - nSET/nRST; Matrix C - CLK (DLY_OUT connected to D)
				CNT/DLY → LUT	00110: Matrix A - In2; Matrix B - DLY_IN; Matrix C - In0 (DLY_OUT connected to In1)
				CNT/DLY → DFF	10110: Matrix A - D; Matrix B - DLY_IN; Matrix C - CLK (DLY_OUT connected to nSET/nRST)
				CNT/DLY → LUT	01010: Matrix A - In2; Matrix B - In1; Matrix C - DLY_IN (DLY_OUT connected to In0)
CNT/DLY → DFF		11010: Matrix A - D; Matrix B - nSET/nRST; Matrix C - DLY_IN (DLY_OUT connected to CLK)			
LUT → CNT/DLY		00011: Matrix A - In2; Matrix B - In1; Matrix C - In0 (LUT_OUT connected to DLY_IN)			
DFF → CNT/DLY	10011: Matrix A - D; Matrix B - nSET/nRST; Matrix C - CLK (DFF_OUT connected to DLY_IN)				
90	1153	CNT6 DLY EDET FUNCTION Selection	0: normal 1: DLY function edge detection (registers[1142:1139]=0000/ 0001/0010)		
	1154	CNT6 CNT mode SYNC selection	0: bypass 1: after two DFF		
	1155	CNT6 initial value selection	00: bypass the initial 01: initial 0 10: initial 1 11: initial 1		
	1156				
90	1157	CNT7 initial value selection	00: bypass the initial 01: initial 0 10: initial 1 11: initial 1		
	1158				
	1159	CNT7 CNT mode SYNC selection	0: bypass 1: after two DFF		

**Auto AEC-Q100 Qualified GreenPAK Programmable Mixed-Signal Matrix**
**Table 57: Register Map (Continued)**

Address		Signal Function	Register Bit Definition
Byte	Register Bit		
91	1160	CNT7 DLY EDET FUNCTION Selection	0: normal 1: DLY function edge detection (registers [1174:1171]=0000/0001/0010)
	1161, 1165:1162	Single 3-bit LUT	00000: Matrix A - In2; Matrix B - In1; Matrix C - In0 (DLY_IN - LOW)
		Single DFF w RST and SET	10000: Matrix A - D; Matrix B - nSET/nRST; Matrix C - CLK (DLY_IN - LOW)
		Single CNT/DLY	00001: Matrix A - DLY_IN (CNT); Matrix B - EXT_CLK (CNT); Matrix C - NC (DLY_OUT connected to LUT/DFF)
		CNT/DLY → LUT	00010: Matrix A - DLY_IN; Matrix B - In1; Matrix C - In0 (DLY_OUT connected to In2)
		CNT/DLY → DFF	10010: Matrix A - DLY_IN; Matrix B - nSET/nRST; Matrix C - CLK (DLY_OUT connected to D)
		CNT/DLY → LUT	00110: Matrix A - In2; Matrix B - DLY_IN; Matrix C - In0 (DLY_OUT connected to In1)
		CNT/DLY → DFF	10110: Matrix A - D; Matrix B - DLY_IN; Matrix C - CLK (DLY_OUT connected to nSET/nRST)
		CNT/DLY → LUT	01010: Matrix A - In2; Matrix B - In1; Matrix C - DLY_IN (DLY_OUT connected to In0)
		CNT/DLY → DFF	11010: Matrix A - D; Matrix B - nSET/nRST; Matrix C - DLY_IN (DLY_OUT connected to CLK)
		LUT → CNT/DLY	00011: Matrix A - In2; Matrix B - In1; Matrix C - In0 (LUT_OUT connected to DLY_IN)
		DFF → CNT/DLY	10011: Matrix A - D; Matrix B - nSET/nRST; Matrix C - CLK (DFF_OUT connected to DLY_IN)

**Auto AEC-Q100 Qualified GreenPAK Programmable Mixed-Signal Matrix**
**Table 57: Register Map (Continued)**

Address		Signal Function	Register Bit Definition
Byte	Register Bit		
91	1166	DLY/CNT7 Clock Source Select	Clock source sel[3:0] 0000: 25M(OSC2); 0001: 25M/4; 0010: 2M(OSC1); 0011: 2M/8; 0100: 2M/64; 0101: 2M/512; 0110: 2K(OSC0); 0111: 2K/8; 1000: 2K/64; 1001: 2K/512; 1010: 2K/4096; 1011: 2K/32768; 1100: 2K/262144; 1101: CNT6_END; 1110: External; 1111: Not used
	1167		
	1168		
92	1169		
	1170	CNT7 output pol selection	0: Default Output 1: Inverted Output
	1171	CNT7 function and edge mode selection	0000: both edge Delay; 0001: falling edge delay; 0010: rising edge delay; 0011: both edge One Shot; 0100: falling edge One Shot; 0101: rising edge One Shot; 0110: both edge freq detect; 0111: falling edge freq detect; 1000: rising edge freq detect; 1001: both edge detect; 1010: falling edge detect; 1011: rising edge detect; 1100: both edge reset CNT; 1101: falling edge reset CNT; 1110: rising edge reset CNT; 1111: high level reset CNT
	1172		
	1173		
1174			
1175	Reserved		
93	1176	Multi0_LUT4_DFF setting	[15]:LUT4_1 [15]/DFF20 or LATCH Select 0: DFF function, 1: LATCH function [14]:LUT4_1 [14]/DFF20 Output Select 0: Q output, 1: QB output [13]:LUT4_1 [13]/DFF20 Initial Polarity Select 0: Low, 1: High [12:0]:LUT4_1 [12:0]
	1177		
	1178		
	1179		
	1180		
	1181		
	1182		
	1183		
94	1184		
	1185		
	1186		
	1187		
	1188		
	1189		
	1190		
	1191		

# SLG46855-A

## Auto AEC-Q100 Qualified GreenPAK Programmable Mixed-Signal Matrix

**Table 57: Register Map (Continued)**

Address		Signal Function	Register Bit Definition
Byte	Register Bit		
95	1192	REG_CNT0_D[15:0]	Data[15:0]
	1193		
	1194		
	1195		
	1196		
	1197		
	1198		
	1199		
96	1200	REG_CNT0_D[15:0]	Data[15:0]
	1201		
	1202		
	1203		
	1204		
	1205		
	1206		
	1207		
97	1208	Multi1_LUT3_DFF setting	[7]:LUT3_9 [7]/DFF13 or LATCH Select 0: DFF function, 1: LATCH function [6]:LUT3_9 [6]/DFF13 Output Select 0: Q output, 1: QB output [5]:LUT3_9 [5]/DFF13 0: nRST from Matrix Output, 1: nSET from Matrix Output [4]:LUT3_9 [4]/DFF13 Initial Polarity Select 0: Low, 1: High [3:0]:LUT3_9 [3:0]
	1209		
	1210		
	1211		
	1212		
	1213		
	1214		
	1215		
98	1216	REG_CNT1_D[7:0]	Data[7:0]
	1217		
	1218		
	1219		
	1220		
	1221		
	1222		
	1223		
99	1224	Multi2_LUT3_DFF setting	[7]:LUT3_10 [7]/DFF14 or LATCH Select 0: DFF function, 1: LATCH function [6]:LUT3_10[6]/DFF14 Output Select 0: Q output, 1: QB output [5]:LUT3_10 [5]/DFF14 0: nRST from Matrix Output, 1: nSET from Matrix Output [4]:LUT3_10 [4]/DFF14 Initial Polarity Select 0: Low, 1: High [3:0]:LUT3_10 [3:0]
	1225		
	1226		
	1227		
	1228		
	1229		
	1230		
	1231		
9A	1232	REG_CNT2_D[7:0]	Data[7:0]
	1233		
	1234		
	1235		
	1236		
	1237		
	1238		
	1239		

# SLG46855-A

## Auto AEC-Q100 Qualified GreenPAK Programmable Mixed-Signal Matrix

**Table 57: Register Map (Continued)**

Address		Signal Function	Register Bit Definition
Byte	Register Bit		
9B	1240	Multi3_LUT3_DFF setting	[7]:LUT3_11 [7]/DFF15 or LATCH Select 0: DFF function, 1: LATCH function [6]:LUT3_11[6]/DFF15 Output Select 0: Q output, 1: QB output [5]:LUT3_11 [5]/DFF15 0: nRST from Matrix Output, 1: nSET from Matrix Output [4]:LUT3_11 [4]/DFF15 Initial Polarity Select 0: Low, 1: High [3:0]:LUT3_11 [3:0]
	1241		
	1242		
	1243		
	1244		
	1245		
	1246		
	1247		
9C	1248	REG_CNT3_D[7:0]	Data[7:0]
	1249		
	1250		
	1251		
	1252		
	1253		
	1254		
	1255		
9D	1256	Multi4_LUT3_DFF setting	[7]:LUT3_12 [7]/DFF16 or LATCH Select 0: DFF function, 1: LATCH function [6]:LUT3_12[6]/DFF16 Output Select 0: Q output, 1: QB output [5]:LUT3_12 [5]/DFF16 0: nRST from Matrix Output, 1: nSET from Matrix Output [4]:LUT3_12 [4]/DFF16 Initial Polarity Select 0: Low, 1: High [3:0]:LUT3_12 [3:0]
	1257		
	1258		
	1259		
	1260		
	1261		
	1262		
	1263		
9E	1264	REG_CNT4_D[7:0]	Data[7:0]
	1265		
	1266		
	1267		
	1268		
	1269		
	1270		
	1271		
9F	1272	Multi5_LUT3_DFF setting	[7]:LUT3_13 [7]/DFF17 or LATCH Select 0: DFF function, 1: LATCH function [6]:LUT3_13[6]/DFF17 Output Select 0: Q output, 1: QB output [5]:LUT3_13 [5]/DFF17 0: nRST from Matrix Output, 1: nSET from Matrix Output [4]:LUT3_13 [4]/DFF17 Initial Polarity Select 0: Low, 1: High [3:0]:LUT3_13 [3:0]
	1273		
	1274		
	1275		
	1276		
	1277		
	1278		
	1279		
A0	1280	REG_CNT5_D[7:0]	Data[7:0]
	1281		
	1282		
	1283		
	1284		
	1285		
	1286		
	1287		

# SLG46855-A

## Auto AEC-Q100 Qualified GreenPAK Programmable Mixed-Signal Matrix

**Table 57: Register Map (Continued)**

Address		Signal Function	Register Bit Definition
Byte	Register Bit		
A1	1288	Multi6_LUT3_DFF setting	[7]:LUT3_14 [7]/DFF18 or LATCH Select 0: DFF function, 1: LATCH function [6]:LUT3_14[6]/DFF18 Output Select 0: Q output, 1: QB output [5]:LUT3_14 [5]/DFF18 0: nRST from Matrix Output, 1: nSET from Matrix Output [4]:LUT3_14 [4]/DFF18 Initial Polarity Select 0: Low, 1: High [3:0]:LUT3_14 [3:0]
	1289		
	1290		
	1291		
	1292		
	1293		
	1294		
	1295		
A2	1296	REG_CNT6_D[7:0]	Data[7:0]
	1297		
	1298		
	1299		
	1300		
	1301		
	1302		
	1303		
A3	1304	Multi7_LUT3_DFF setting	[7]:LUT3_15 [7]/DFF19 or LATCH Select 0: DFF function, 1: LATCH function [6]:LUT3_15[6]/DFF19 Output Select 0: Q output, 1: QB output [5]:LUT3_15 [5]/DFF19 0: nRST from Matrix Output, 1: nSET from Matrix Output [4]:LUT3_15 [4]/DFF19 Initial Polarity Select 0: Low, 1: High [3:0]:LUT3_15 [3:0]
	1305		
	1306		
	1307		
	1308		
	1309		
	1310		
	1311		
A4	1312	REG_CNT7_D[7:0]	Data[7:0]
	1313		
	1314		
	1315		
	1316		
	1317		
	1318		
	1319		
A5	1320	CNT0 (16bits) Counted Value	Virtual Input
	1321		
	1322		
	1323		
	1324		
	1325		
	1326		
	1327		
	A6		
1329			
1330			
1331			
1332			
1333			
1334			
1335			

**Auto AEC-Q100 Qualified GreenPAK Programmable Mixed-Signal Matrix**
**Table 57: Register Map (Continued)**

Address		Signal Function	Register Bit Definition
Byte	Register Bit		
A7	1336	CNT6 (8bits) Counted Value	Virtual Input
	1337		
	1338		
	1339		
	1340		
	1341		
	1342		
	1343		
A8	1344	CNT7 (8bits) Counted Value	Virtual Input
	1345		
	1346		
	1347		
	1348		
	1349		
	1350		
	1351		
A9	1352	LUT3_1_DFF4 setting	[7]:LUT3_1 [7]/DFF4 or LATCH Select 0: DFF function, 1: LATCH function [6]:LUT3_1 [6]/DFF4 Output Select 0: Q output, 1: QB output [5]:LUT3_1 [5]/DFF4 Initial Polarity Select 0: Low, 1: High [4]:LUT3_1 [4]/DFF4 0: nRST from Matrix Output, 1: nSET from Matrix Output [3]:LUT3_1 [3]/DFF4 Active level selection for RST/SET 0: Active low level reset/set, 1: Active high level reset/set [2:0]: LUT3_1 [2:0]
	1353		
	1354		
	1355		
	1356		
	1357		
	1358		
	1359		
AA	1360	LUT3_2_DFF5 setting	[7]:LUT3_2 [7]/DFF5 or LATCH Select 0: DFF function, 1: LATCH function [6]:LUT3_2 [6]/DFF5 Output Select 0: Q output, 1: QB output [5]:LUT3_2 [5]/DFF5 Initial Polarity Select 0: Low, 1: High [4]:LUT3_2 [4]/DFF5 0: nRST from Matrix Output, 1: nSET from Matrix Output [3]:LUT3_2 [3]/DFF5 Active level selection for RST/SET 0: Active low level reset/set, 1: Active high level reset/set [2:0]: LUT3_2 [2:0]
	1361		
	1362		
	1363		
	1364		
	1365		
	1366		
	1367		
AB	1368	LUT3_3_DFF6 setting	[7]:LUT3_3 [7]/DFF6 or LATCH Select 0: DFF function, 1: LATCH function [6]:LUT3_3 [6]/DFF6 Output Select 0: Q output, 1: QB output [5]:LUT3_3 [5]/DFF6 Initial Polarity Select 0: Low, 1: High [4]:LUT3_3 [4]/DFF6 0: nRST from Matrix Output, 1: nSET from Matrix Output [3]:LUT3_3 [3]/DFF6 Active level selection for RST/SET 0: Active low level reset/set, 1: Active high level reset/set [2:0]: LUT3_3 [2:0]
	1369		
	1370		
	1371		
	1372		
	1373		
	1374		
	1375		



# SLG46855-A

## Auto AEC-Q100 Qualified GreenPAK Programmable Mixed-Signal Matrix

**Table 57: Register Map (Continued)**

Address		Signal Function	Register Bit Definition		
Byte	Register Bit				
AC	1376	LUT3_4_DFF7 setting	[7]:LUT3_4 [7]/DFF7 or LATCH Select 0: DFF function, 1: LATCH function [6]:LUT3_4 [6]/DFF7 Output Select 0: Q output, 1: QB output [5]:LUT3_4 [5]/DFF7 Initial Polarity Select 0: Low, 1: High [4]:LUT3_4 [4]/DFF7 0: nRST from Matrix Output, 1: nSET from Matrix Output [3]:LUT3_4 [3]/DFF7 Active level selection for RST/SET 0: Active low level reset/set, 1: Active high level reset/set [2:0]: LUT3_4 [2:0]		
	1377				
	1378				
	1379				
	1380				
	1381				
	1382				
	1383				
AD	1384	LUT2_3_VAL or PGen_data	LUT2_3[3:0] or PGen 4bit counter data[3:0]		
	1385				
	1386				
	1387				
	1388	LUT3_1 or DFF4 Select	0: LUT3_1 1: DFF4		
	1389	LUT3_2 or DFF5 Select	0: LUT3_2 1: DFF5		
	1390	LUT3_3 or DFF6 Select	0: LUT3_3 1: DFF6		
	1391	LUT3_4 or DFF7 Select	0: LUT3_4 1: DFF7		
AE	1392	PGen data	PGen Data[15:0]		
	1393				
	1394				
	1395				
	1396				
	1397				
	1398				
	1399				
AF	1400			PGen data	PGen Data[15:0]
	1401				
	1402				
	1403				
	1404				
	1405				
	1406				
	1407				

**Auto AEC-Q100 Qualified GreenPAK Programmable Mixed-Signal Matrix**
**Table 57: Register Map (Continued)**

Address		Signal Function	Register Bit Definition
Byte	Register Bit		
B0	1408	LUT2_3 or PGen Select	0: LUT2_3 1: PGen
	1409	Active level selection for RST/SET for LUT2_3 or PGen	0: Active low level reset/set 1: Active high level reset/set
	1410	Active level selection for RST/SET for LUT3_16 or Pipe Delay/RIPP CNT	0: Active low level reset/set 1: Active high level reset/set
	1411	Out of LUT3_16 or Out0 of Pipe Delay/RIPP CNT Select	0: LUT3_16 1: OUT0 of Pipe Delay or RIPP CNT
	1412	PIPE_RIPP_CNT_S	0: Pipe delay mode selection 1: Ripple Counter mode selection
	1413	Pipe Delay OUT1 Polarity Select	0: Non-inverted 1: Inverted
	1414	LUT4_0 or DFF12 Select	0: LUT4_0 1: DFF12
	1415	LUT3_0 or DFF3 Select	0: LUT3_0 1: DFF3
B1	1416	LUT value or pipe delay out sel or nSET/END value	[7:4]: LUT3_8 [7:4]/REG_S1[3:0] pipe delay out1 sel [3:0]: LUT3_8 [3:0]/REG_S0[3:0] pipe delay out0 sel at RIPP CNT mode: bit[1418:1416] is the nSET value bit[1421:1419] is the END value bit[1422] is the range control: 0 full cycle, 1 range cycle bit[1423] Not used
	1417		
	1418		
	1419		
	1420		
	1421		
	1422		
	1423		
B2	1424	LUT4_0_DFF12 setting	[15]:LUT4_0 [15]/DFF12 or LATCH Select 0: DFF function, 1: LATCH function [14]:LUT4_0 [14]/DFF12 Output Select 0: Q output, 1: QB output [13]:LUT4_0 [13]/DFF12 Initial Polarity Select 0: Low, 1: High [12]:LUT4_0 [12]/DFF12 stage selection 0: Q of first DFF; 1 Q of second DFF [11]:LUT4_0 [11]/DFF12 0: nRST from Matrix Output, 1: nSET from Matrix Output [10]:LUT4_0 [10]/DFF12 Active level selection for RST/SET 0: Active low level reset/set, 1: Active high level reset/set [9:0]: LUT4_0 [9:0]
	1425		
	1426		
	1427		
	1428		
	1429		
	1430		
	1431		
B3	1432	LUT3_0_DFF3 setting	[7]:LUT3_0 [7]/DFF3 or LATCH Select 0: DFF function, 1: LATCH function [6]:LUT3_0 [6]/DFF3 Output Select 0: Q output, 1: QB output [5]:LUT3_0 [5]/DFF3 Initial Polarity Select 0: Low, 1: High [4]:LUT3_0 [4]/DFF3stage selection 0: Q of first DFF; 1 Q of second DFF [3]:LUT3_0 [3]/DFF3 0: nRST from Matrix Output, 1: nSET from Matrix Output [2]:LUT3_0 [2]/DFF3 Active level selection for RST/SET 0: Active low level reset/set, 1: Active high level reset/set [1:0]: LUT3_0 [1:0]
	1433		
	1434		
	1435		
	1436		
	1437		
	1438		
	1439		
B4	1440	LUT3_0_DFF3 setting	[7]:LUT3_0 [7]/DFF3 or LATCH Select 0: DFF function, 1: LATCH function [6]:LUT3_0 [6]/DFF3 Output Select 0: Q output, 1: QB output [5]:LUT3_0 [5]/DFF3 Initial Polarity Select 0: Low, 1: High [4]:LUT3_0 [4]/DFF3stage selection 0: Q of first DFF; 1 Q of second DFF [3]:LUT3_0 [3]/DFF3 0: nRST from Matrix Output, 1: nSET from Matrix Output [2]:LUT3_0 [2]/DFF3 Active level selection for RST/SET 0: Active low level reset/set, 1: Active high level reset/set [1:0]: LUT3_0 [1:0]
	1441		
	1442		
	1443		
	1444		
	1445		
	1446		
	1447		

**Auto AEC-Q100 Qualified GreenPAK Programmable Mixed-Signal Matrix**
**Table 57: Register Map (Continued)**

Address		Signal Function	Register Bit Definition
Byte	Register Bit		
B5	1448	Filter or Edge Detector selection	0, filter 1, edge det
	1449	Output Polarity Select	0: output non-invert 1: output invert
	1450	Select the edge mode	00: Rising Edge Det 01: Falling Edge Det 10: Both Edge Det 11: Both Edge DLY
	1451		
	1452	Delay Value Select for Programmable Delay & Edge Detector	00: 125 ns 01: 250 ns 10: 375 ns 11: 500 ns
	1453		
	1454		
1455	Select the Edge Mode of Programmable Delay & Edge Detector	00: Rising Edge Detector 01: Falling Edge Detector 10: Both Edge Detector 11: Both Edge Delay	
B6	1456	LUT3_5_DFF8 setting	[7]:LUT3_5 [7]/DFF8 or LATCH Select 0: DFF function, 1: LATCH function
	1457		[6]:LUT3_5 [6]/DFF8 Output Select 0: Q output, 1: QB output
	1458		[5]:LUT3_5 [5]/DFF8 Initial Polarity Select 0: Low, 1: High
	1459		[4]:LUT3_5 [4]/DFF8 0: nRST from Matrix Output, 1: nSET from Matrix Output
	1460		[3]:LUT3_5 [3]/DFF8 Active level selection for RST/SET 0: Active low level reset/set, 1: Active high level reset/set
	1461		[2:0]: LUT3_5 [2:0]
	1462		
B7	1464	LUT3_6_DFF9 setting	[7]:LUT3_6 [7]/DFF9 or LATCH Select 0: DFF function, 1: LATCH function
	1465		[6]:LUT3_6 [6]/DFF9 Output Select 0: Q output, 1: QB output
	1466		[5]:LUT3_6 [5]/DFF9 Initial Polarity Select 0: Low, 1: High
	1467		[4]:LUT3_6 [4]/DFF9 0: nRST from Matrix Output, 1: nSET from Matrix Output
	1468		[3]:LUT3_6 [3]/DFF9 Active level selection for RST/SET 0: Active low level reset/set, 1: Active high level reset/set
	1469		[2:0]: LUT3_6 [2:0]
	1470		
B8	1472	LUT3_7_DFF10 setting	[7]:LUT3_7 [7]/DFF10 or LATCH Select 0: DFF function, 1: LATCH function
	1473		[6]:LUT3_7 [6]/DFF10 Output Select 0: Q output, 1: QB output
	1474		[5]:LUT3_7 [5]/DFF10 Initial Polarity Select 0: Low, 1: High
	1475		[4]:LUT3_7 [4]/DFF10 0: nRST from Matrix Output, 1: nSET from Matrix Output
	1476		[3]:LUT3_7 [3]/DFF10 Active level selection for RST/SET 0: Active low level reset/set, 1: Active high level reset/set
	1477		[2:0]: LUT3_7 [2:0]
	1478		
B9	1480	LUT3_8_DFF11 setting	[7]:LUT3_8 [7]/DFF11 or LATCH Select 0: DFF function, 1: LATCH function
	1481		[6]:LUT3_8 [6]/DFF11 Output Select 0: Q output, 1: QB output
	1482		[5]:LUT3_8 [5]/DFF11 Initial Polarity Select 0: Low, 1: High
	1483		[4]:LUT3_8 [4]/DFF11 0: nRST from Matrix Output, 1: nSET from Matrix Output
	1484		[3]:LUT3_8 [3]/DFF11 Active level selection for RST/SET 0: Active low level reset/set, 1: Active high level reset/set
	1485		[2:0]: LUT3_8 [2:0]
	1486		
1487			

# SLG46855-A

## Auto AEC-Q100 Qualified GreenPAK Programmable Mixed-Signal Matrix

**Table 57: Register Map (Continued)**

Address		Signal Function	Register Bit Definition
Byte	Register Bit		
BA	1488	LUT2_0 or DFF0 Select	0: LUT2_0 1: DFF0
	1489	LUT2_1 or DFF1 Select	0: LUT2_1 1: DFF1
	1490	LUT2_2 or DFF2 Select	0: LUT2_2 1: DFF2
	1491	Reserved	
	1492	LUT3_5 or DFF8 Select	0: LUT3_5 1: DFF8
	1493	LUT3_6 or DFF9 Select	0: LUT3_6 1: DFF9
	1494	LUT3_7 or DFF10 Select	0: LUT3_7 1: DFF10
	1495	LUT3_8 or DFF11 Select	0: LUT3_8 1: DFF11
BB	1496	LUT2_0/DFF0 setting	[3]:LUT2_0 [3]/DFF0 or LATCH Select 0: DFF function, 1: LATCH function
	1497		[2]:LUT2_0 [2]/DFF0 Output Select 0: Q output, 1: QB output
	1498		[1]:LUT2_0 [1]/DFF0 Initial Polarity Select 0: Low, 1: High
	1499		[0]:LUT2_0 [0]
	1500	LUT2_1/DFF1 setting	[3]:LUT2_1 [3]/DFF1 or LATCH Select 0: DFF function, 1: LATCH function
	1501		[2]:LUT2_1 [2]/DFF1 Output Select 0: Q output, 1: QB output
	1502		[1]:LUT2_1 [1]/DFF1 Initial Polarity Select 0: Low, 1: High
	1503		[0]:LUT2_1 [0]
BC	1504	LUT2_2/DFF2 setting	[3]:LUT2_2 [3]/DFF2 or LATCH Select 0: DFF function, 1: LATCH function
	1505		[2]:LUT2_2 [2]/DFF2 Output Select 0: Q output, 1: QB output
	1506		[1]:LUT2_2 [1]/DFF2 Initial Polarity Select 0: Low, 1: High
	1507		[0]:LUT2_2 [0]
	1508	Reserved	
	1509		
	1510		
	1511		
BD	1512	Reserved	
	1513		
	1514		
	1515		
	1516		
	1517		
	1518		
	1519		

# SLG46855-A

## Auto AEC-Q100 Qualified GreenPAK Programmable Mixed-Signal Matrix

**Table 57: Register Map (Continued)**

Address		Signal Function	Register Bit Definition
Byte	Register Bit		
BE	1520	Reserved	
	1521	Reserved	
	1522	Reserved	
	1523	Reserved	
	1524	Reserved	
	1525		
	1526		
	1527		
BF	1528	Reserved	
	1529	Reserved	
	1530	Reserved	
	1531	Reserved	
	1532	Reserved	
	1533	Reserved	
	1534	Reserved	
	1535	Reserved	
C0	1536	Reserved	
	1537	Reserved	
	1538	Reserved	
	1539	Reserved	
	1540	Reserved	
	1541	Reserved	
	1542	Reserved	
	1543	Reserved	
C1	1544	Reserved	
	1545	Reserved	
	1546	Reserved	
	1547	Reserved	
	1548	Reserved	
	1549	Reserved	
	1550	Reserved	
	1551	Reserved	
C2	1552	Reserved	
	1553	Reserved	
	1554	Reserved	
	1555	Reserved	
	1556	Reserved	
	1557	Reserved	
	1558	Reserved	
	1559	Reserved	
C3	1560	Reserved	
	1561	Reserved	
	1562	Reserved	
	1563	Reserved	
	1564	Reserved	
	1565	Reserved	
	1566	Reserved	
	1567	Reserved	

# SLG46855-A

## Auto AEC-Q100 Qualified GreenPAK Programmable Mixed-Signal Matrix

**Table 57: Register Map (Continued)**

Address		Signal Function	Register Bit Definition
Byte	Register Bit		
C4	1568	Reserved	
	1569	Reserved	
	1570	Reserved	
	1571	Reserved	
	1572	Reserved	
	1573	Reserved	
	1574	Reserved	
	1575	Reserved	
C5	1576	Reserved	
	1577	Reserved	
	1578	Reserved	
	1579	Reserved	
	1580	Reserved	
	1581	Reserved	
	1582	Reserved	
	1583	Reserved	
C6	1584	Reserved	
	1585	Reserved	
	1586	Reserved	
	1587	Reserved	
	1588	Reserved	
	1589	Reserved	
	1590	Reserved	
	1591	Reserved	
C7	1592	Reserved	
	1593	Reserved	
	1594	Reserved	
	1595	Reserved	
	1596	Reserved	
	1597	Reserved	
	1598	Reserved	
	1599	Reserved	
C8	1600	Reserved	
	1601	Reserved	
	1602	Reserved	
	1603	Reserved	
	1604	Reserved	
	1605	Reserved	
	1606	Reserved	
	1607	Reserved	
C9	1608	Reserved	
	1609	Reserved	
	1610	Reserved	
	1611	Reserved	
	1612	Reserved	
	1613	Reserved	
	1614	Reserved	
	1615	Reserved	

# SLG46855-A

## Auto AEC-Q100 Qualified GreenPAK Programmable Mixed-Signal Matrix

**Table 57: Register Map (Continued)**

Address		Signal Function	Register Bit Definition
Byte	Register Bit		
CA	1616	Reserved	
	1617	Reserved	
	1618	Reserved	
	1619	Reserved	
	1620	Reserved	
	1621	Reserved	
	1622	Reserved	
CB	1623	Reserved	
	1624	Reserved	
	1625	Reserved	
	1626	Reserved	
	1627	Reserved	
	1628	Reserved	
	1629	Reserved	
CC	1630	Reserved	
	1631	Reserved	
	1632	Reserved	
	1633	Reserved	
	1634	Reserved	
	1635	Reserved	
	1636	Reserved	
CD	1637	Reserved	
	1638	Reserved	
	1639	Reserved	
	1640	Reserved	
	1641	Reserved	
	1642	Reserved	
	1643	Reserved	
CE	1644	Reserved	
	1645	Reserved	
	1646	Reserved	
	1647	Reserved	
	1648	Reserved	
	1649	Reserved	
	1650	Reserved	
CF	1651	Reserved	
	1652	Reserved	
	1653	Reserved	
	1654	Reserved	
	1655	Reserved	
	1656	Reserved	
	1657	Reserved	
CF	1658	Reserved	
	1659	Reserved	
	1660	Reserved	
	1661	Reserved	
	1662	Reserved	
	1663	Reserved	

# SLG46855-A

## Auto AEC-Q100 Qualified GreenPAK Programmable Mixed-Signal Matrix

**Table 57: Register Map (Continued)**

Address		Signal Function	Register Bit Definition
Byte	Register Bit		
D0	1664	Reserved	
	1665	Reserved	
	1666	Reserved	
	1667	Reserved	
	1668	Reserved	
	1669	Reserved	
	1670	Reserved	
	1671	Reserved	
D1	1672	Reserved	
	1673	Reserved	
	1674	Reserved	
	1675	Reserved	
	1676	Reserved	
	1677	Reserved	
	1678	Reserved	
	1679	Reserved	
D2	1680	Reserved	
	1681	Reserved	
	1682	Reserved	
	1683	Reserved	
	1684	Reserved	
	1685	Reserved	
	1686	Reserved	
	1687	Reserved	
D3	1688	Reserved	
	1689	Reserved	
	1690	Reserved	
	1691	Reserved	
	1692	Reserved	
	1693	Reserved	
	1694	Reserved	
	1695	Reserved	
D4	1696	Reserved	
	1697	Reserved	
	1698	Reserved	
	1699	Reserved	
	1700	Reserved	
	1701	Reserved	
	1702	Reserved	
	1703	Reserved	
D5	1704	Reserved	
	1705	Reserved	
	1706	Reserved	
	1707	Reserved	
	1708	Reserved	
	1709	Reserved	
	1710	Reserved	
	1711	Reserved	



# SLG46855-A

## Auto AEC-Q100 Qualified GreenPAK Programmable Mixed-Signal Matrix

**Table 57: Register Map (Continued)**

Address		Signal Function	Register Bit Definition
Byte	Register Bit		
D6	1712	Reserved	
	1713	Reserved	
	1714	Reserved	
	1715	Reserved	
	1716	Reserved	
	1717	Reserved	
	1718	Reserved	
	1719	Reserved	
D7	1720	Reserved	
	1721	Reserved	
	1722	Reserved	
	1723	Reserved	
	1724	Reserved	
	1725	Reserved	
	1726	Reserved	
	1727	Reserved	
D8	1728	Reserved	
	1729	Reserved	
	1730	Reserved	
	1731	Reserved	
	1732	Reserved	
	1733	Reserved	
	1734	Reserved	
	1735	Reserved	
D9	1736	Reserved	
	1737	Reserved	
	1738	Reserved	
	1739	Reserved	
	1740	Reserved	
	1741	Reserved	
	1742	Reserved	
	1743	Reserved	
DA	1744	Reserved	
	1745	Reserved	
	1746	Reserved	
	1747	Reserved	
	1748	Reserved	
	1749	Reserved	
	1750	Reserved	
	1751	Reserved	
DB	1752	Reserved	
	1753	Reserved	
	1754	Reserved	
	1755	Reserved	
	1756	Reserved	
	1757	Reserved	
	1758	Reserved	
	1759	Reserved	

# SLG46855-A

## Auto AEC-Q100 Qualified GreenPAK Programmable Mixed-Signal Matrix

**Table 57: Register Map (Continued)**

Address		Signal Function	Register Bit Definition
Byte	Register Bit		
DC	1760	Reserved	
	1761	Reserved	
	1762	Reserved	
	1763	Reserved	
	1764	Reserved	
	1765	Reserved	
	1766	Reserved	
	1767	Reserved	
DD	1768	Reserved	
	1769	Reserved	
	1770	Reserved	
	1771	Reserved	
	1772	Reserved	
	1773	Reserved	
	1774	Reserved	
	1775	Reserved	
DE	1776	Reserved	
	1777	Reserved	
	1778	Reserved	
	1779	Reserved	
	1780	Reserved	
	1781	Reserved	
	1782	Reserved	
	1783	Reserved	
DF	1784	Reserved	
	1785	Reserved	
	1786	Reserved	
	1787	Reserved	
	1788	Reserved	
	1789	Reserved	
	1790	Reserved	
	1791	Reserved	
E0	1792	Reserved	
	1793	Reserved	
	1794	Reserved	
	1795	Reserved	
	1796	Reserved	
	1797	Reserved	
	1798	Reserved	
	1799	Reserved	
E1	1800	Reserved	
	1801	Reserved	
	1802	Reserved	
	1803	Reserved	
	1804	Reserved	
	1805	Reserved	
	1806	Reserved	
	1807	Reserved	

# SLG46855-A

## Auto AEC-Q100 Qualified GreenPAK Programmable Mixed-Signal Matrix

**Table 57: Register Map (Continued)**

Address		Signal Function	Register Bit Definition
Byte	Register Bit		
E2	1808	Reserved	
	1809	Reserved	
	1810	Reserved	
	1811	Reserved	
	1812	Reserved	
	1813	Reserved	
	1814	Reserved	
	1815	Reserved	
E3	1816	Reserved	
	1817	Reserved	
	1818	Reserved	
	1819	Reserved	
	1820	Reserved	
	1821	Reserved	
	1822	Reserved	
	1823	Reserved	
E4	1824	Reserved	
	1825	Reserved	
	1826	Reserved	
	1827	Reserved	
	1828	Reserved	
	1829	Reserved	
	1830	Reserved	
	1831	Reserved	
E5	1832	Reserved	
	1833	Reserved	
	1834	Reserved	
	1835	Reserved	
	1836	Reserved	
	1837	Reserved	
	1838	Reserved	
	1839	Reserved	
E6	1840	Reserved	
	1841	Reserved	
	1842	Reserved	
	1843	Reserved	
	1844	Reserved	
	1845	Reserved	
	1846	Reserved	
	1847	Reserved	
E7	1848	Reserved	
	1849	Reserved	
	1850	Reserved	
	1851	Reserved	
	1852	Reserved	
	1853	Reserved	
	1854	Reserved	
	1855	Reserved	

# SLG46855-A

## Auto AEC-Q100 Qualified GreenPAK Programmable Mixed-Signal Matrix

**Table 57: Register Map (Continued)**

Address		Signal Function	Register Bit Definition
Byte	Register Bit		
E8	1856	Reserved	
	1857	Reserved	
	1858	Reserved	
	1859	Reserved	
	1860	Reserved	
	1861	Reserved	
	1862	Reserved	
	1863	Reserved	
E9	1864	Reserved	
	1865	Reserved	
	1866	Reserved	
	1867	Reserved	
	1868	Reserved	
	1869	Reserved	
	1870	Reserved	
	1871	Reserved	
EA	1872	Reserved	
	1873	Reserved	
	1874	Reserved	
	1875	Reserved	
	1876	Reserved	
	1877	Reserved	
	1878	Reserved	
	1879	Reserved	
EB	1880	Reserved	
	1881	Reserved	
	1882	Reserved	
	1883	Reserved	
	1884	Reserved	
	1885	Reserved	
	1886	Reserved	
	1887	Reserved	
EC	1888	Reserved	
	1889	Reserved	
	1890	Reserved	
	1891	Reserved	
	1892	Reserved	
	1893	Reserved	
	1894	Reserved	
	1895	Reserved	
ED	1896	Reserved	
	1897	Reserved	
	1898	Reserved	
	1899	Reserved	
	1900	Reserved	
	1901	Reserved	
	1902	Reserved	
	1903	Reserved	

# SLG46855-A

## Auto AEC-Q100 Qualified GreenPAK Programmable Mixed-Signal Matrix

**Table 57: Register Map (Continued)**

Address		Signal Function	Register Bit Definition
Byte	Register Bit		
EE	1904	Reserved	
	1905	Reserved	
	1906	Reserved	
	1907	Reserved	
	1908	Reserved	
	1909	Reserved	
	1910	Reserved	
	1911	Reserved	
EF	1912	Reserved	
	1913	Reserved	
	1914	Reserved	
	1915	Reserved	
	1916	Reserved	
	1917	Reserved	
	1918	Reserved	
	1919	Reserved	
F0	1920	Reserved	
	1921	Reserved	
	1922	Reserved	
	1923	Reserved	
	1924	Reserved	
	1925	Reserved	
	1926	Reserved	
	1927	Reserved	
F1	1928	Reserved	
	1929	Reserved	
	1930	Reserved	
	1931	Reserved	
	1932	Reserved	
	1933	Reserved	
	1934	Reserved	
	1935	Reserved	
F2	1936	Reserved	
	1937	Reserved	
	1938	Reserved	
	1939	Reserved	
	1940	Reserved	
	1941	Reserved	
	1942	Reserved	
	1943	Reserved	
F3	1944	Reserved	
	1945	Reserved	
	1946	Reserved	
	1947	Reserved	
	1948	Reserved	
	1949	Reserved	
	1950	Reserved	
	1951	Reserved	

# SLG46855-A

## Auto AEC-Q100 Qualified GreenPAK Programmable Mixed-Signal Matrix

**Table 57: Register Map (Continued)**

Address		Signal Function	Register Bit Definition
Byte	Register Bit		
F4	1952	GPO0 I2C output expander data	
	1953	GPO0 I2C output expander select	0: GPO0 output come from matrix 1: GPO0 output is register
	1954	GPIO6 I2C output expander data	
	1955	GPIO6 I2C output expander select	0: GPIO6 output come from matrix 1: GPIO6 output is register
	1956	GPIO7 I2C output expander data	
	1957	GPIO7 I2C output expander select	0: GPIO7 output come from matrix 1: GPIO7 output is register
	1958	GPIO8 I2C output expander data	
	1959	GPIO8 I2C output expander select	0: GPIO8 output come from matrix 1: GPIO8 output is register
F5	1960	I2C reset bit with reloading NVM into Data register (soft reset)	0: Keep existing condition 1: Reset execution
	1961	IO Latching Enable During I2C Write Interface	0: Disable 1: Enable
	1962	Reserved	
	1963	Protect mode enable	0: Disable 1: Enable
	1964	Reserved	
	1965	Register protection mode bit 0	000: all open read/write (mode 0); 001: partly lock read (mode 1); 010: partly lock read2 (mode 2); 011: partly lock read2/write (mode 3); 100: all lock read (mode 4); 101: all lock write (mode 5); 110: all lock read/write (mode 6).
	1966	Register protection mode bit 1	
F6	1967	Register protection mode bit 2	
	1968	I <sup>2</sup> C write mask bits	1: mask 0: overwrite
	1969		
	1970		
	1971		
	1972		
	1973		
	1974		
1975			
F7	1976	Reserved	
	1977		
	1978		
	1979		
	1980		
	1981		
	1982		
	1983		
F8	1984	Reserved	
	1985		
	1986		
	1987		
	1988		
	1989		
	1990		
1991			

# SLG46855-A

## Auto AEC-Q100 Qualified GreenPAK Programmable Mixed-Signal Matrix

**Table 57: Register Map (Continued)**

Address		Signal Function	Register Bit Definition
Byte	Register Bit		
F9	1992	Reserved	
	1993	Reserved	
	1994	Reserved	
	1995		
	1996	Reserved	
	1997		
	1998		
	1999		
FA	2000	8-bit Pattern ID Byte 0 (from NVM): ID[23:16]	
	2001		
	2002		
	2003		
	2004		
	2005		
	2006		
	2007		
FB	2008	Reserved	
	2009		
	2010		
	2011		
	2012		
	2013		
	2014		
	2015		
FC	2016	Reserved	
	2017		
	2018		
	2019		
	2020		
	2021		
	2022		
	2023		
FD	2024	I <sup>2</sup> C slave address	
	2025		
	2026		
	2027		
	2028	Slave address selection bit0	0: from register [2024] 1: from GPIO0
	2029	Slave address selection bit1	0: from register [2025] 1: from GPIO2
	2030	Slave address selection bit2	0: from register [2026] 1: from GPIO4
2031	Slave address selection bit3	0: from register [2027] 1: from GPIO5	

# SLG46855-A

## Auto AEC-Q100 Qualified GreenPAK Programmable Mixed-Signal Matrix

**Table 57: Register Map (Continued)**

Address		Signal Function	Register Bit Definition
Byte	Register Bit		
FE	2032	I2C operation disable bit	0: I2C operation enable; matrix in 32(33) select I2C_virtual_0(1) Input 1: I2C operation disable; matrix in 32(33) select GPIO0(GPIO1) digital input
	2033	Reserved	
	2034	Reserved	
	2035	Reserved	
	2036	Reserved	
	2037	Reserved	
	2038	Reserved	
	2039	Reserved	
FF	2040	Reserved	
	2041		
	2042		
	2043		
	2044		
	2045		
	2046		
	2047		



SLG46855-A

Auto AEC-Q100 Qualified GreenPAK Programmable  
Mixed-Signal Matrix

18 Package Top Marking Definitions

18.1 FCQFN 14L 3MM X 3 MM 0.65P FCD

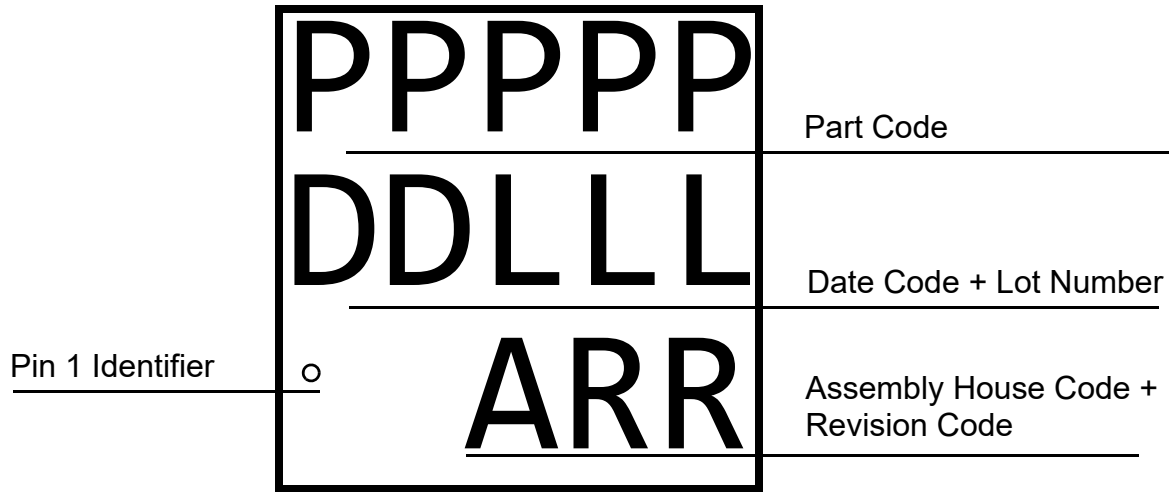

SLG46855-A

Auto AEC-Q100 Qualified GreenPAK Programmable Mixed-Signal Matrix

19 Package Information

19.1 PACKAGE OUTLINES FOR FCQFN 14L 3.0 MM X 3.0 MM X 0.55 MM 0.65P FC PACKAGE

JEDEC MO-220  
IC Net Weight: 0.0115 g

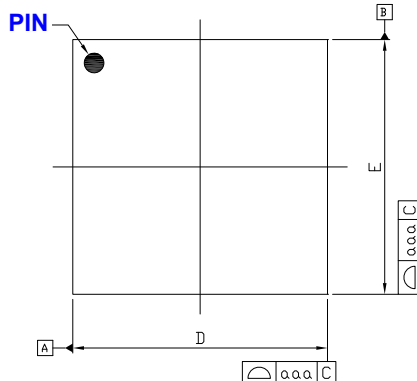

Top View

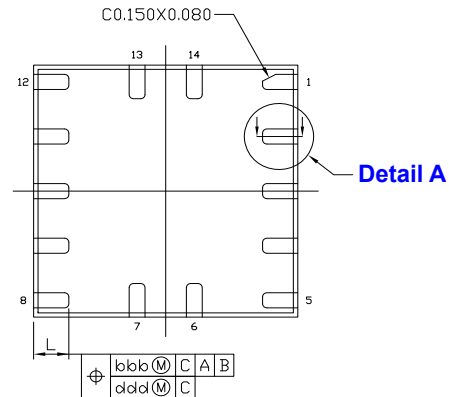

Bottom View

Wettable Flank

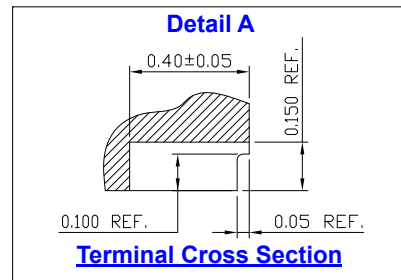

Terminal Cross Section

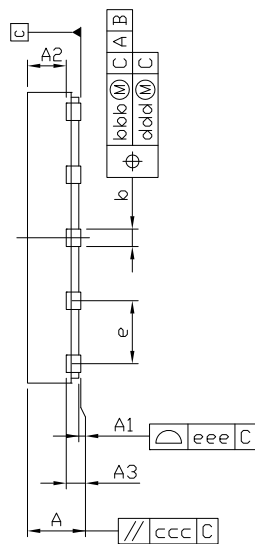

Marking View

Controlling Dimensions: mm

SYMBOLS	MILLIMETER			INCH		
	MIN.	NOM.	MAX.	MIN.	NOM.	MAX.
A	0.50	0.55	0.60	0.020	0.022	0.024
A1	0.00	0.02	0.05	0.000	0.001	0.002
A2	0.35	0.40	0.45	0.014	0.016	0.018
A3	0.10	0.15	0.20	0.004	0.006	0.008
b	0.13	0.18	0.23	0.005	0.007	0.009
D	2.95	3.00	3.05	0.116	0.118	0.120
E	2.95	3.00	3.05	0.116	0.118	0.120
e	0.65 BSC			0.026 BSC		
L	0.35	0.40	0.45	0.014	0.016	0.018
aaa	0.07			0.003		
bbb	0.07			0.003		
ccc	0.10			0.004		
ddd	0.05			0.002		
eee	0.08			0.003		

Standard Tolerance:  $\pm 0.05$

# SLG46855-A

## Auto AEC-Q100 Qualified GreenPAK Programmable Mixed-Signal Matrix

### 19.2 FCQFN HANDLING

Be sure to handle FCQFN package only in a clean, ESD-safe environment. Tweezers or vacuum pick-up tools are suitable for handling. Do not handle FCQFN package with fingers as this can contaminate the package pins and interface with solder re-flow.

### 19.3 SOLDERING INFORMATION

Please see IPC/JEDEC J-STD-020: latest revision for re-flow profile based on package volume of 2.64 mm<sup>3</sup> (nominal) for FCQFN 14L Package. More information can be found at [www.jedec.org](http://www.jedec.org).

## 20 Ordering Information

Part Number	Type
SLG46855-AP	14-pin FCQFN
SLG46855-APTR	14-pin FCQFN - Tape and Reel (5k units)

**Note 1** Use SLG46855-AP to order. Shipments are automatically in Tape and Reel.

**Note 2** "TR" suffix is no longer used. It is a legacy naming convention shown here only for informational purposes.

### 20.1 TAPE AND REEL SPECIFICATIONS

Package Type	# of Pins	Nominal Package Size (mm)	Max Units		Reel & Hub Size (mm)	Leader (min)		Trailer (min)		Tape Width (mm)	Part Pitch (mm)
			per Reel	per Box		Pockets	Length (mm)	Pockets	Length (mm)		
FCQFN 14L 3 mm x 3 mm 0.65P FC Green	14	3.0 x 3.0 x 0.55	5000	10000	330/102	50	400	50	400	12	8

### 20.2 CARRIER TAPE DRAWING AND DIMENSIONS

Package Type	Pocket BTM Length (mm)	Pocket BTM Width (mm)	Pocket Depth (mm)	Index Hole Pitch (mm)	Pocket Pitch (mm)	Index Hole Diameter (mm)	Index Hole to Tape Edge (mm)	Index Hole to Pocket Center (mm)	Tape Width (mm)
	A0	B0	K0	P0	P1	D0	E	F	W
FCQFN 14L 3.0 mm x 3.0 mm 0.65P FC Green	3.3	3.3	0.8	4	8	1.5	1.75	5.5	12

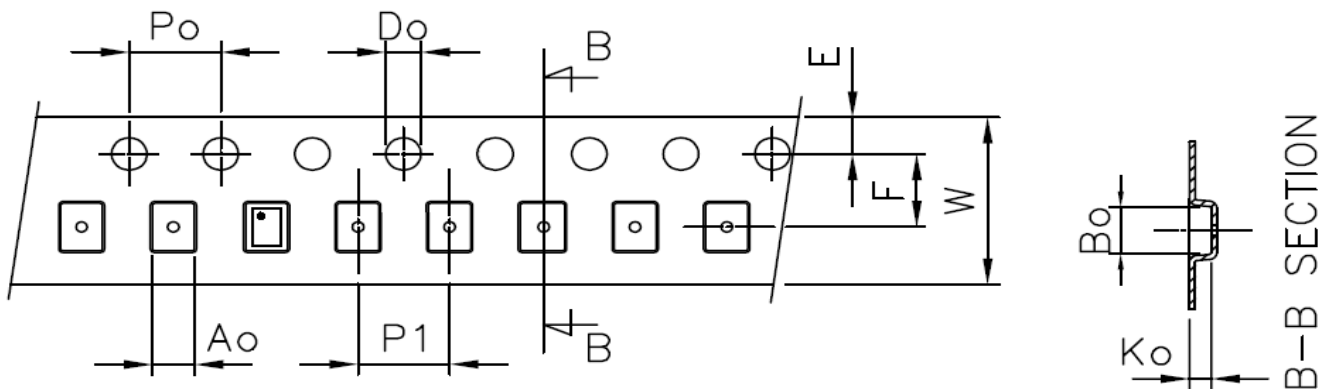



SLG46855-A

Auto AEC-Q100 Qualified GreenPAK Programmable Mixed-Signal Matrix

21 Layout Guidelines

21.1 FCQFN 14L 3 MM X 3 MM X 0.5 MM 0.65P FC GREEN

Expose Pad  (Package face down)

Recommended Landing Pattern  (Package face down)

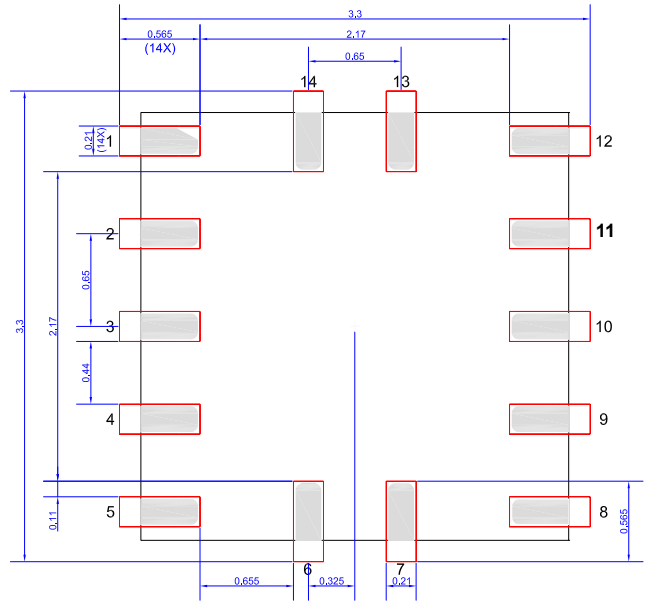
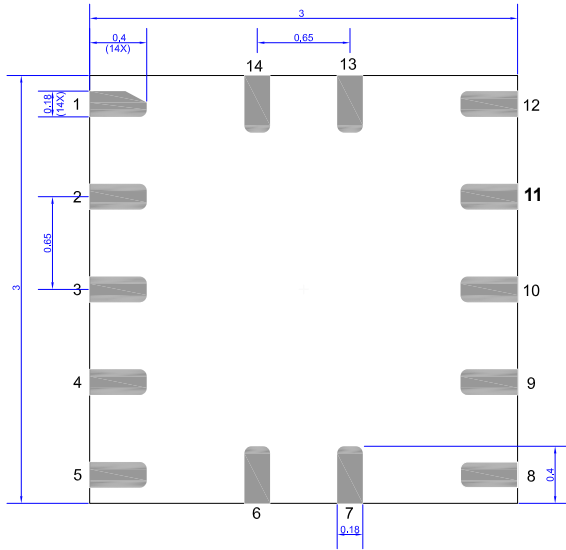

Unit: mm

## SLG46855-A

### Auto AEC-Q100 Qualified GreenPAK Programmable Mixed-Signal Matrix

#### Glossary

##### A

ACK	Acknowledge bit
ACMP	Analog Comparator
ACMPH	Analog Comparator High Speed
ACMPL	Analog Comparator Low Power
ADAS	Advanced Driver Assistance Systems

##### B

BG	Bandgap
----	---------

##### C

CLK	Clock
CMO	Connection matrix output
CNT	Counter

##### D

DFF	D Flip-Flop
DLY	Delay

##### E

ESD	Electrostatic discharge
EV	End Value

##### F

FSM	Finite State Machine
-----	----------------------

##### G

GPI	General Purpose Input
GPIO	General Purpose Input/Output
GPO	General Purpose Output

##### I

IN	Input
IO	Input/Output

##### L

LPF	Low Pass Filter
LSB	Least Significant Bit

## SLG46855-A

### Auto AEC-Q100 Qualified GreenPAK Programmable Mixed-Signal Matrix

LUT            Look Up Table  
 LV             Low Voltage

#### M

MSB           Most Significant Bit  
 MUX           Multiplexer

#### N

NPR           Non-Volatile Memory Read/Write/Erase Protection  
 nRST          Reset  
 NVM           Non-Volatile Memory

#### O

OD             Open-Drain  
 OE             Output Enable  
 OSC           Oscillator  
 OTP           one time programmable  
 OUT           Output

#### P

PD             Power-down  
 PGen          Pattern Generator  
 POR           Power-On Reset  
 PP             Push-Pull  
 PWR           Power  
 P DLY         Programmable Delay

#### R

R/W           Read/Write

#### S

SCL           I<sup>2</sup>C Clock Input  
 SDA           I<sup>2</sup>C Data Input/Output  
 SLA           Slave Address  
 SMT           With Schmitt Trigger  
 SV             nSET Value

#### T

TS             Temperature Sensor

## SLG46855-A

---

### Auto AEC-Q100 Qualified GreenPAK Programmable Mixed-Signal Matrix

#### V

Vref            Voltage Reference

#### W

WOSMT        Without Schmitt Trigger

WS             Wake and Sleep Controller

**Auto AEC-Q100 Qualified GreenPAK Programmable  
Mixed-Signal Matrix**
**Revision History**

Revision	Date	Description
3.8	2-May-2024	Corrected figure I <sup>2</sup> C General Timing Characteristics Corrected table I <sup>2</sup> C Pins Timing Characteristics, DILV Mode Corrected parameter symbols of Data Valid Acknowledge Time and Data Valid Time in table I <sup>2</sup> C Pins Timing Characteristics, DI Mode
3.7	2-Feb-2024	Fixed typos Updated registers [2007:2000]
3.6	16-Nov-2023	Corrected section Package Top Marking Definitions
3.5	23-May-2023	Updated tables captions in section Characteristics Updated information in table Recommended Operating Conditions Fixed typos
3.4	28-Feb-2023	Added notes to section Ordering Information
3.3	13-Dec-2022	Added additional information about AEC-Q100
3.2	19-Oct-2022	Fixed typos in sections Layout Guidelines and Characteristics
3.1	7-Mar-2022	Updated R <sub>PULL</sub> in section Electrical Characteristics Renesas rebranding Added IC Net Weight in Package Information section Updated bytes 5B, 5C, 5D, 5E and 5F in the Register map Added information about SCL and SDA Pins' Schmitt Trigger Updated section GPIO8 Source for Oscillator 2 (25 MHz)
3.0	17-Jun-2021	Final version



## SLG46855-A

### Auto AEC-Q100 Qualified GreenPAK Programmable Mixed-Signal Matrix

#### Status Definitions

Revision	Datasheet Status	Product Status	Definition
1.<n>	Target	Development	This datasheet contains the design specifications for product development. Specifications may change in any manner without notice.
2.<n>	Preliminary	Qualification	This datasheet contains the specifications and preliminary characterization data for products in pre-production. Specifications may be changed at any time without notice in order to improve the design.
3.<n>	Final	Production	This datasheet contains the final specifications for products in volume production. The specifications may be changed at any time in order to improve the design, manufacturing and supply. Major specification changes are communicated via Customer Product Notifications. Datasheet changes are communicated via <a href="http://www.renesas.com">www.renesas.com</a> .
4.<n>	Obsolete	Archived	This datasheet contains the specifications for discontinued products. The information is provided for reference only.

#### RoHS Compliance

Renesas Electronics Corporation's suppliers certify that its products are in compliance with the requirements of Directive 2011/65/EU of the European Parliament on the restriction of the use of certain hazardous substances in electrical and electronic equipment. RoHS certificates from our suppliers are available on request.

## Notice

1. Descriptions of circuits, software and other related information in this document are provided only to illustrate the operation of semiconductor products and application examples. You are fully responsible for the incorporation or any other use of the circuits, software, and information in the design of your product or system. Renesas Electronics disclaims any and all liability for any losses and damages incurred by you or third parties arising from the use of these circuits, software, or information.
2. Renesas Electronics hereby expressly disclaims any warranties against and liability for infringement or any other claims involving patents, copyrights, or other intellectual property rights of third parties, by or arising from the use of Renesas Electronics products or technical information described in this document, including but not limited to, the product data, drawings, charts, programs, algorithms, and application examples.
3. No license, express, implied or otherwise, is granted hereby under any patents, copyrights or other intellectual property rights of Renesas Electronics or others.
4. You shall be responsible for determining what licenses are required from any third parties, and obtaining such licenses for the lawful import, export, manufacture, sales, utilization, distribution or other disposal of any products incorporating Renesas Electronics products, if required.
5. You shall not alter, modify, copy, or reverse engineer any Renesas Electronics product, whether in whole or in part. Renesas Electronics disclaims any and all liability for any losses or damages incurred by you or third parties arising from such alteration, modification, copying or reverse engineering.
6. Renesas Electronics products are classified according to the following two quality grades: "Standard" and "High Quality". The intended applications for each Renesas Electronics product depends on the product's quality grade, as indicated below.
  - "Standard": Computers; office equipment; communications equipment; test and measurement equipment; audio and visual equipment; home electronic appliances; machine tools; personal electronic equipment; industrial robots; etc.
  - "High Quality": Transportation equipment (automobiles, trains, ships, etc.); traffic control (traffic lights); large-scale communication equipment; key financial terminal systems; safety control equipment; etc.
- Unless expressly designated as a high reliability product or a product for harsh environments in a Renesas Electronics data sheet or other Renesas Electronics document, Renesas Electronics products are not intended or authorized for use in products or systems that may pose a direct threat to human life or bodily injury (artificial life support devices or systems; surgical implantations; etc.), or may cause serious property damage (space system; undersea repeaters; nuclear power control systems; aircraft control systems; key plant systems; military equipment; etc.). Renesas Electronics disclaims any and all liability for any damages or losses incurred by you or any third parties arising from the use of any Renesas Electronics product that is inconsistent with any Renesas Electronics data sheet, user's manual or other Renesas Electronics document.
7. No semiconductor product is absolutely secure. Notwithstanding any security measures or features that may be implemented in Renesas Electronics hardware or software products, Renesas Electronics shall have absolutely no liability arising out of any vulnerability or security breach, including but not limited to any unauthorized access to or use of a Renesas Electronics product or a system that uses a Renesas Electronics product. RENESAS ELECTRONICS DOES NOT WARRANT OR GUARANTEE THAT RENESAS ELECTRONICS PRODUCTS, OR ANY SYSTEMS CREATED USING RENESAS ELECTRONICS PRODUCTS WILL BE INVULNERABLE OR FREE FROM CORRUPTION, ATTACK, VIRUSES, INTERFERENCE, HACKING, DATA LOSS OR THEFT, OR OTHER SECURITY INTRUSION ("Vulnerability Issues"). RENESAS ELECTRONICS DISCLAIMS ANY AND ALL RESPONSIBILITY OR LIABILITY ARISING FROM OR RELATED TO ANY VULNERABILITY ISSUES. FURTHERMORE, TO THE EXTENT PERMITTED BY APPLICABLE LAW, RENESAS ELECTRONICS DISCLAIMS ANY AND ALL WARRANTIES, EXPRESS OR IMPLIED, WITH RESPECT TO THIS DOCUMENT AND ANY RELATED OR ACCOMPANYING SOFTWARE OR HARDWARE, INCLUDING BUT NOT LIMITED TO THE IMPLIED WARRANTIES OF MERCHANTABILITY, OR FITNESS FOR A PARTICULAR PURPOSE.
8. When using Renesas Electronics products, refer to the latest product information (data sheets, user's manuals, application notes, "General Notes for Handling and Using Semiconductor Devices" in the reliability handbook, etc.), and ensure that usage conditions are within the ranges specified by Renesas Electronics with respect to maximum ratings, operating power supply voltage range, heat dissipation characteristics, installation, etc. Renesas Electronics disclaims any and all liability for any malfunctions, failure or accident arising out of the use of Renesas Electronics products outside of such specified ranges.
9. Although Renesas Electronics endeavors to improve the quality and reliability of Renesas Electronics products, semiconductor products have specific characteristics, such as the occurrence of failure at a certain rate and malfunctions under certain use conditions. Unless designated as a high reliability product or a product for harsh environments in a Renesas Electronics data sheet or other Renesas Electronics document, Renesas Electronics products are not subject to radiation resistance design. You are responsible for implementing safety measures to guard against the possibility of bodily injury, injury or damage caused by fire, and/or danger to the public in the event of a failure or malfunction of Renesas Electronics products, such as safety design for hardware and software, including but not limited to redundancy, fire control and malfunction prevention, appropriate treatment for aging degradation or any other appropriate measures. Because the evaluation of microcomputer software alone is very difficult and impractical, you are responsible for evaluating the safety of the final products or systems manufactured by you.
10. Please contact a Renesas Electronics sales office for details as to environmental matters such as the environmental compatibility of each Renesas Electronics product. You are responsible for carefully and sufficiently investigating applicable laws and regulations that regulate the inclusion or use of controlled substances, including without limitation, the EU RoHS Directive, and using Renesas Electronics products in compliance with all these applicable laws and regulations. Renesas Electronics disclaims any and all liability for damages or losses occurring as a result of your noncompliance with applicable laws and regulations.
11. Renesas Electronics products and technologies shall not be used for or incorporated into any products or systems whose manufacture, use, or sale is prohibited under any applicable domestic or foreign laws or regulations. You shall comply with any applicable export control laws and regulations promulgated and administered by the governments of any countries asserting jurisdiction over the parties or transactions.
12. It is the responsibility of the buyer or distributor of Renesas Electronics products, or any other party who distributes, disposes of, or otherwise sells or transfers the product to a third party, to notify such third party in advance of the contents and conditions set forth in this document.
13. This document shall not be reprinted, reproduced or duplicated in any form, in whole or in part, without prior written consent of Renesas Electronics.
14. Please contact a Renesas Electronics sales office if you have any questions regarding the information contained in this document or Renesas Electronics products.

(Note1) "Renesas Electronics" as used in this document means Renesas Electronics Corporation and also includes its directly or indirectly controlled subsidiaries.

(Note2) "Renesas Electronics product(s)" means any product developed or manufactured by or for Renesas Electronics.

(Disclaimer Rev.5.0-1 October 2020)

## Corporate Headquarters

TOYOSU FORESIA, 3-2-24 Toyosu,  
Koto-ku, Tokyo 135-0061, Japan  
[www.renesas.com](http://www.renesas.com)

## Trademarks

Renesas and the Renesas logo are trademarks of Renesas Electronics Corporation. All trademarks and registered trademarks are the property of their respective owners.

## Contact Information

For further information on a product, technology, the most up-to-date version of a document, or your nearest sales office, please visit:  
[www.renesas.com/contact/](http://www.renesas.com/contact/)