

## Description

The 8V79S680 is a fully integrated, clock and SYSREF signal fanout buffer for JESD204B applications. It is designed as a high-performance clock and converter synchronization solution for wireless base station radio equipment boards with JESD204B subclass 0, 1, and 2 compliance. The main function of the device is the distribution and fanout of high-frequency clocks and low-frequency system reference signals generated by a JESB204B clock generator such as the IDT 8V19N480, extending its fanout capabilities and providing additional phase-delay.

The 8V79S680 is optimized to deliver very low phase noise clocks and precise, phase-adjustable SYSREF synchronization signals as required in GSM, WCDMA, LTE, LTE-A radio board implementations. Low-skew outputs, low device-to-device skew characteristics and fast output rise/fall times help the system design to achieve deterministic clock and SYSREF phase relationship across devices.

The device distributes the input clock (CLK) and JESD204B SYSREF signals (REF) to four fanout channels. In each channel, both input clock and SYSREF signals are fanned-out to multiple clock (QCLK) and SYSREF (QREF) outputs. Clock signals can be frequency-divided in each channel. Configurable phase-delay circuits are available for both clock and SYSREF signals. The propagation delays in all signal paths are fully deterministic to support fixed phase relationships between clock and SYSREF signals within one device. Clock divider can be bypassed for low-latency clock paths. The device facilitates synchronization between frequency dividers within the device and across multiple devices, removing phase ambiguity introduced in dividers between power and configuration cycles.

Each channel supports clock frequencies up to 3GHz. In an alternative configuration, for instance JESD204B subclass 0 and 2, the SYSREF (QREF) outputs can be configured as regular clock outputs adding additional clock fanout to the device.

All outputs are very flexible in amplitude configuration, output signal termination and allow both DC and AC coupling. Outputs can be disabled and powered-down when not used. The SYSREF output pre-bias feature supports prevention of power-on glitches and enables AC-coupling of the system synchronization signals.

The device is configured through a 3-wire SPI serial interface. The device is packaged in a lead-free (RoHS 6) 64-lead VFQFPN package. The extended temperature range supports wireless infrastructure, telecommunication and networking end equipment requirements. The device is a member of the high-performance clock family from IDT.

## Typical Applications

- JESD204B low phase noise clock and SYSREF signal distribution
- Supports JESD204 subclass 0, 1 and 2
- Clock distribution device for jitter-sensitive ADC and DAC circuits
- Wireless infrastructure
- Radar and imaging
- Instrumentation and medical

## Features

- Supports high-speed, low phase noise converter clocks
- Distribution, fanout, phase-delay of clock and SYSREF signals
- Very low output noise floor: -158.8dBc/Hz noise floor (245.76MHz)
- Supports clock frequencies up to 3GHz, including clock output frequencies of 983.04MHz, 491.52MHz, 245.76MHz, and 122.88MHz
- 4 output channels with a total of 16 differential outputs, organized in:
  - 8 dedicated clock outputs
  - 8 outputs configurable as SYSREF outputs with individual phase delay stages, or configurable as additional clock outputs
- Each channel contains:
  - Frequency dividers: ÷1, ÷2, ÷4, ÷6, ÷8, ÷12, ÷16
  - Clock phase delay circuits
- Clock phase delay circuits
  - Clock: delay unit is the clock period; 256 steps
  - SYSREF: Configurable precision phase delay circuits: 8 steps of 131ps, 262ps, 393ps, or 524ps
- Flexible differential outputs:
  - LVDS/LVPECL configurable
  - Amplitude configurable
  - Power-down modes for unused outputs
  - Supports DC and AC coupling
  - QREF (SYSREF) output pre-bias feature to prevent glitches when turning output on or off
- Supply voltage:
  - 3.3V core and signal I/O
  - 1.8V Digital control SPI I/O (3.3V-tolerant inputs)
- 64 VFQFPN package (9 × 9 × 0.85 mm)
- Ambient temperature range: -40°C to +85°C

# Contents

Description .....	1
Typical Applications .....	1
Features .....	1
Contents .....	2
Block Diagram .....	3
Pin Assignments .....	4
Pin Descriptions .....	5
Principles of Operation .....	7
Overview .....	7
Signal Flow .....	7
Clock Channel Divider .....	7
Phase Delay .....	8
Delay Calibration Block (DCB) .....	8
QCLK to SYSREF Phase Alignment .....	10
Differential Outputs .....	11
Device Startup, Reset, and Synchronization .....	13
Changing Frequency Dividers and Phase Delay Values .....	13
SPI Interface .....	14
Register Descriptions .....	16
Channel and Clock Output Registers .....	19
QREF Output State Registers .....	21
SYSREF Control Registers .....	24
General Control Registers .....	26
Electrical Characteristics .....	28
Absolute Maximum Ratings .....	28
Pin Characteristics .....	28
DC Characteristics .....	29
AC Characteristics .....	32
Additive Clock Phase Noise Characteristics .....	35
Application Information .....	41
Termination for QCLK <sub>y</sub> , QREF <sub>r</sub> LVDS Outputs (STYLE = 0) .....	41
AC Termination for QCLK <sub>y</sub> , QREF <sub>r</sub> LVDS Outputs (STYLE = 0) .....	41
Termination for QCLK <sub>y</sub> , QREF <sub>r</sub> LVPECL Outputs (STYLE = 1) .....	42
Package Exposed Pad Thermal Release Path .....	42
Thermal Characteristics .....	43
Case Temperature Considerations .....	43
Example Calculation for Junction Temperature (T <sub>J</sub> ): T <sub>J</sub> = T <sub>CB</sub> + Y <sub>JB</sub> x PD .....	44
Package Outline Drawings .....	44
Ordering Information .....	44
Marking Diagram .....	44
Glossary .....	45
Revision History .....	45

# Block Diagram

Figure 1. Block Diagram

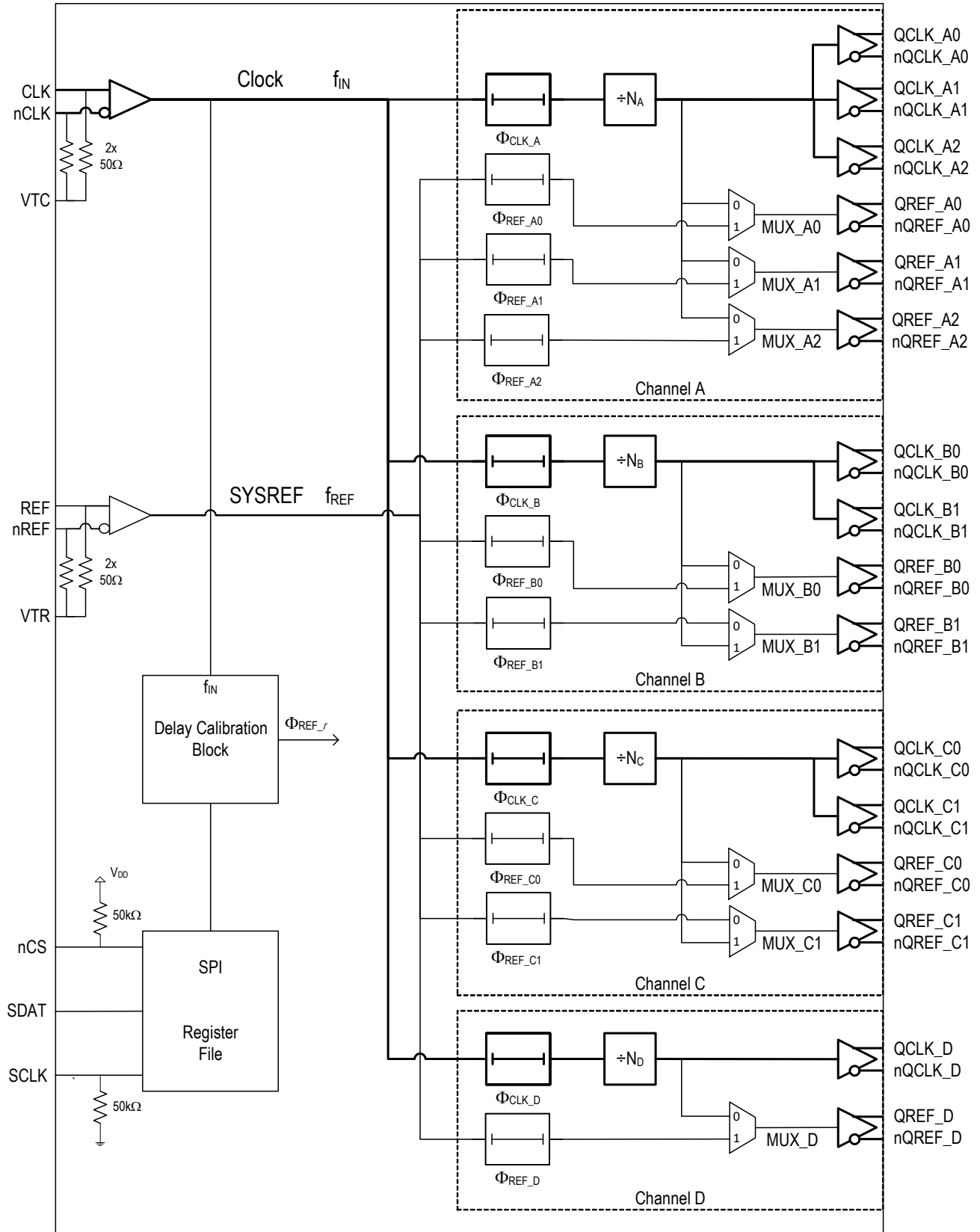

## Pin Assignments

Figure 2. Pin Assignments 9 x 9 x 0.85 mm 64-VFQFPN Package (Top View)

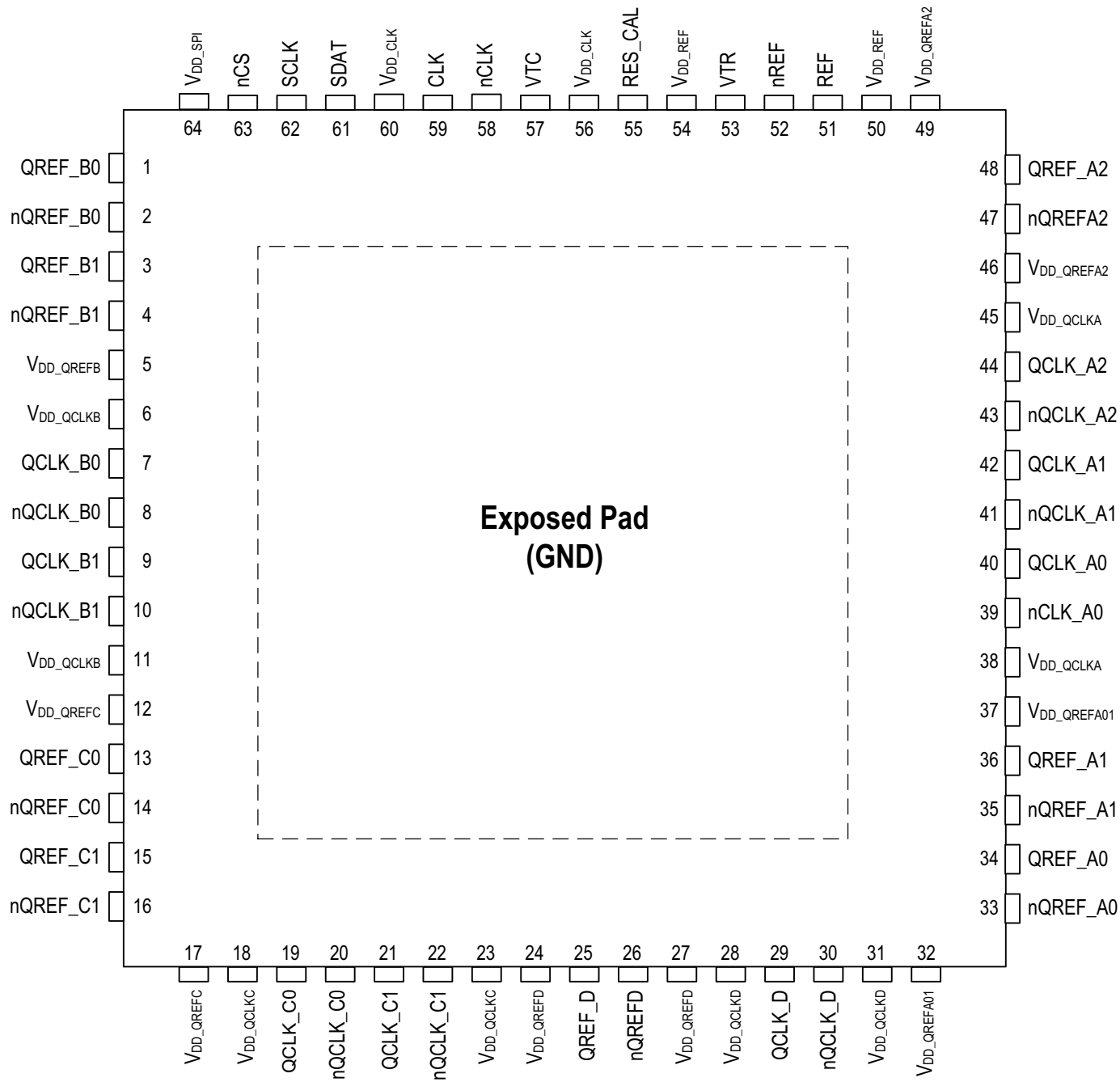

## Pin Descriptions

Table 1. Pin Descriptions

Number	Name	Type <sup>[a]</sup>	Description
1, 2	QREF_B0, nQREF_B0	Output	Differential SYSREF/clock output QREF_B0. LVDS style for SYSREF operation, configurable LVPECL/LVDS style and amplitude for clock operation.
3, 4	QREF_B1, nQREF_B1	Output	Differential SYSREF/clock output QREF_B1. LVDS style for SYSREF operation, configurable LVPECL/LVDS style and amplitude for clock operation.
5	V <sub>DD_QREFB</sub>	Power	Positive supply voltage (3.3V) for the QREF_B[1:0] outputs.
6	V <sub>DD_QCLKB</sub>	Power	Positive supply voltage (3.3V) for the QCLK_B[1:0] outputs.
7, 8	QCLK_B0, nQCLK_B0	Output	Differential clock output QCLK_B0. Configurable LVPECL/LVDS style and amplitude.
9, 10	QCLK_B1, nQCLK_B1	Output	Differential clock output QCLK_B1. Configurable LVPECL/LVDS style and amplitude.
11	V <sub>DD_QCLKB</sub>	Power	Positive supply voltage (3.3V) for the QCLK_B[1:0] outputs.
12	V <sub>DD_QREFC</sub>	Power	Positive supply voltage (3.3V) for the QREF_C[1:0] outputs.
13, 14	QREF_C0, nQREF_C0	Output	Differential SYSREF/clock output QREF_C0. LVDS style for SYSREF operation, configurable LVPECL/LVDS style and amplitude for clock operation.
15, 16	QREF_C1, nQREF_C1	Output	Differential SYSREF/clock output QREF_C1. LVDS style for SYSREF operation, configurable LVPECL/LVDS style and amplitude for clock operation.
17	V <sub>DD_QREFC</sub>	Power	Positive supply voltage (3.3V) for the QREF_C[1:0] outputs.
18	V <sub>DD_QCLKC</sub>	Power	Positive supply voltage (3.3V) for the QCLK_C[1:0] outputs.
19, 20	QCLK_C0, nQCLK_C0	Output	Differential clock output QCLK_C0. Configurable LVPECL/LVDS style and amplitude.
21, 22	QCLK_C1, nQCLK_C1	Output	Differential clock output QCLK_C1. Configurable LVPECL/LVDS style and amplitude.
23	V <sub>DD_QCLKC</sub>	Power	Positive supply voltage (3.3V) for the QCLK_C[1:0] outputs.
24	V <sub>DD_QREFD</sub>	Power	Positive supply voltage (3.3V) for the QREF_D outputs.
25, 26	QREF_D, nQREF_D	Output	Differential SYSREF/clock output QREF_D. LVDS style for SYSREF operation, configurable LVPECL/LVDS style and amplitude for clock operation.
27	V <sub>DD_QREFD</sub>	Power	Positive supply voltage (3.3V) for the QREF_D outputs.
28	V <sub>DD_QCLKD</sub>	Power	Positive supply voltage (3.3V) for the QCLK_D outputs.
29, 30	QCLK_D, nQCLK_D	Output	Differential clock output QCLK_D. Configurable LVPECL/LVDS style and amplitude.
31	V <sub>DD_QCLKD</sub>	Power	Positive supply voltage (3.3V) for the QCLK_D outputs.
32	V <sub>DD_QREFA01</sub>	Power	Positive supply voltage (3.3V) for the QREF_A[1:0] outputs.
33, 34	nQREF_A0, QREF_A0	Output	Differential SYSREF/clock output QREF_A0. LVDS style for SYSREF operation, configurable LVPECL/LVDS style and amplitude for clock operation.
35, 36	nQREF_A1, QREF_A1	Output	Differential SYSREF/clock output QREF_A1. LVDS style for SYSREF operation, configurable LVPECL/LVDS style and amplitude for clock operation.
37	V <sub>DD_QREFA01</sub>	Power	Positive supply voltage (3.3V) for the QREF_A[1:0] outputs.
38	V <sub>DD_QCLKA</sub>	Power	Positive supply voltage (3.3V) for the QCLK_A[2:0] outputs.

Table 1. Pin Descriptions (Cont.)

Number	Name	Type <sup>[a]</sup>		Description
39, 40	nQCLK_A0, QCLK_A0	Output		Differential clock output QCLK_A0. Configurable LVPECL/LVDS style and amplitude.
41, 42	nQCLK_A1, QCLK_A1	Output		Differential clock output QCLK_A1. Configurable LVPECL/LVDS style and amplitude.
43, 44	nQCLK_A2, QCLK_A2	Output		Differential clock output QCLK_A2. Configurable LVPECL/LVDS style and amplitude.
45	V <sub>DD_QCLKA</sub>	Power		Positive supply voltage (3.3V) for the QCLK_A[2:0] outputs.
46	V <sub>DD_QREFA2</sub>	Power		Positive supply voltage (3.3V) for the QREF_A2 output.
47, 48	nQREF_A2, QREF_A2	Output		Differential SYSREF/clock output QREF_A2. LVDS style for SYSREF operation, configurable LVPECL/LVDS style and amplitude for clock operation.
49	V <sub>DD_QREFA2</sub>	Power		Positive supply voltage (3.3V) for the QREF_A2 output.
50	V <sub>DD_REF</sub>	Power		Positive supply voltage (3.3V) for the differential SYSREF input REF, nREF
51, 52	REF, nREF	Input		SYSREF inverting and non-inverting differential input. Compatible with LVPECL and LVDS signals. REF and nREF are internally 50Ω terminated to the VTR pin
53	VTR	–		Internal termination for the differential clock input REF, nREF. Both REF and nREF inputs are internally terminated 50Ω to this pin. See input termination information in <a href="#">Application Information</a> .
54	V <sub>DD_REF</sub>	Power		Positive supply voltage (3.3V) for the differential SYSREF input REF, nREF
55	RES_CAL	Analog		Connect a 2.8 kΩ (1%) resistor to GND for output current calibration.
56	V <sub>DD_CLK</sub>	Power		Positive supply voltage (3.3V) for the differential device clock input CLK, nCLK.
57	VTC	–		Internal termination for the differential clock input CLK, nCLK. Both CLK and nCLK inputs are internally 50Ω terminated to the VTC pin. See input termination information in <a href="#">Application Information</a> .
58, 59	nCLK, CLK	Input		Device clock inverting and non-inverting differential clock input. Compatible with LVPECL and LVDS signals. CLK and nCLK are internally terminated to VTC through 50Ω.
60	V <sub>DD_CLK</sub>	Power		Positive supply voltage (3.3V) for the differential device clock input CLK, nCLK.
61	SDAT	Input/ Output		Serial Control Port SPI Mode Data Input and Output. 1.8V LVCMOS/LVTTL interface levels. 3.3V tolerant when input.
62	SCLK	Input	PD	Serial Control Port SPI Mode Clock Input. 1.8V LVCMOS/LVTTL interface levels. 3.3V-tolerant when input.
63	nCS	Input	PU	Serial Control Port SPI Chip Select Input. 1.8V LVCMOS/LVTTL interface levels and 3.3V tolerant.
64	V <sub>DD_SPI</sub>	Power		Positive supply voltage (3.3V) for the SPI interface.
Exposed Pad (EP)	GND	Power		Ground supply voltage (GND) and ground return path. Connect to board GND (0V).

[a] Internal pull-up (PU) and pull-down (PD) resistors are indicated in parentheses. See [Table 22](#) for values.

# Principles of Operation

## Overview

The 8V79S680 is a JESD204B Fanout Buffer with Configurable Phase Delay. The device supports the division, phase-delay and distribution of high-frequency clocks (input: CLK, nCLK) and the fanout and phase-delay of low-frequency synchronization (SYSREF) signals (input: REF/nREF). Clock and SYSREF signal paths are independent and are organized in channels, with each channel consisting of several clock and SYSREF outputs. Outputs are configurable with support for LVPECL, LVDS and four amplitude settings. Individual channels and unused circuit blocks support a powered-down state for reduced power consumption operation. The register map, accessible through a SPI interface with read-back capability controls the main device settings.

## Signal Flow

The device offers four channels with the names A, B, C and D. Each channel supports individual frequency-division, phase-delay and fan-out functions of the input clock to a total of eight QCLK\_y clock outputs; each channel also distributes the SYSREF input signal to multiple QREF\_r outputs with individual per-output phase delay capability.

The central clock distribution ensures low skew clock outputs within each channel; outputs are synchronous across channels (independent on the divider setting) on the incident rising clock edge for all outputs with equal phase delay settings.

SYSREF output are synchronous with each other for equal phase-delay settings. QCLK\_y and QREF\_r outputs will be phase-locked to each other if the CLK and REF inputs are phase-locked. The phase-delay capability in each signal path can be used to establish repeatable and deterministic clock to SYSREF phase relationships at the outputs.

The CLK and QREF signal paths are optimized for channel isolation. allowing high-speed clocks of 983.04MHz, 1474.56MHz or 1966.08MHz (up to 3GHz) and lower-speed SYSREF signals at e.g. 7.68MHz or 9.6MHz with a minimum of signal crosstalk and spurious signals.

## Clock Channel Divider

Each of the four independent frequency dividers  $N_A$ - $N_D$  can be individually set to the divider values  $\div 1$ ,  $\div 2$ ,  $\div 4$ ,  $\div 6$ ,  $\div 8$ ,  $\div 12$ ,  $\div 16$ . The dividers are synchronous and have an equal propagation delay on the incident edge. See [Table 2](#) for the supported frequency divider settings.

Table 2.  $N_{A-D}$  Frequency Divider Settings

$N_{A-D}$	Clock Divider
000	$\div 1$ Divider bypass and powered down
001	$\div 2$
010	$\div 4$
011	$\div 6$
100	$\div 8$
101	$\div 12$
110	$\div 16$
111	Not defined

## Phase Delay

Output phase delay is independently supported on each clock channel and each SYSREF output. The delay unit of the clock channel phase-delay circuits  $\Phi_{CLK\_x}$  is a function of the frequency  $f_{IN}$  applied to CLK input:  $1 \div f_{IN}$ .

The delay unit of the SYSREF phase-delay circuits  $\Phi_{REF\_r}$  is a function of an internal oscillator frequency  $f_{DCO}$  and the DLC multiplier setting. The oscillator is fully self-contained and located in delay calibration block (DCB). At startup, this oscillator is calibrated with the input frequency  $f_{IN}$  as reference. After the calibration, the oscillator is turned-off to save power and to eliminate noise. See [Table 3](#) for details on the delay unit, number of available steps and the delay range.

Table 3. Delay Circuit Characteristics

Delay Circuit	Unit	Steps	Range
Clock channel $\Phi_{CLK\_x}$	$1 \div f_{IN}$  1.017ns at $f_{IN} = 983.04\text{MHz}$	256	$256 \div f_{IN}$ <sup>[a]</sup>  0 to 259.3ns at $f_{IN} = 983.04\text{MHz}$
SYSREF $\Phi_{REF\_r}$	$T_{DCB}$ <sup>[b]</sup>  DLC = 0: 131ps DLC = 1: 262ps DLC = 2: 393ps DLC = 3: 524ps	8	$0 \dots 7 * T_{DCB}$ <sup>[c]</sup>  DLC = 0: 0 to 0.917ns DLC = 1: 0 to 1.834ns DLC = 2: 0 to 2.751ns DLC = 3: 0 to 3.668ns

[a] At  $f_{IN} = 983.04\text{MHz}$ , the clock channel delay range is equal to 260.416ns and encompasses 32 periods of a 122.88MHz clock signal.

[b]  $T_{DCB} \sim \text{DLC} \div (8 \cdot f_{DCO})$ .  $f_{DCO} = 983.04\text{MHz}$ . DLC = 1, 2, 3 or 4.

[c] SYSREF phase delay supports  $\geq 8$  delay stops within one input reference period for  $f_{IN} = 254.76\text{MHz}$  to  $f_{IN} = 983.04\text{MHz}$ .

## Delay Calibration Block (DCB)

The DCB sets the *SYSREF* delay unit by providing a reference signal to the QREF\_r delay circuits. [Figure 3](#) shows the functional diagram. The DCB requires configuration and calibration. Verification of the calibration is optional.

**Description.** The DCB consists of an internal DCO running at  $f_{DCO} = 983.04 \pm 20\text{MHz}$ , three frequency dividers  $P_{DCB}$ ,  $M_{DCB}$  and  $N_{DCB}$  and a digital hold circuit. The DCB input frequency is the device input frequency  $f_{IN}$  at the differential CLK, nCLK input. The input frequency acts as a reference to lock the oscillator to a stable and known frequency.

The output of the DCB is the effective delay unit  $T_{DCB}$  which is approx. one eighth of the oscillator period multiplied by the DLC multiplier. The DLC multiplier extends the delay unit by a factor of 1, 2, 3 or 4. For instance, at a DCO frequency of 983.04MHz, DLC = 1 sets the SYSREF delay unit to 131ps; DLC = 2 sets the delay unit to 262ps, etc.

**Configuration.** Select a desired delay unit and corresponding DLC multiplier from [Table 4](#). DLC[1:0] also sets the  $N_{DCB}$  divider. Then, find a  $P_{DCB}$  and  $M_{DCB}$  divider configuration to locate the oscillator frequency into the range of  $f_{DCO} = 983.04\text{MHz}$  according to the formula in [Figure 3](#). The DCO lock condition is  $f_1 = f_2$  while both  $f_1$  and  $f_2$  must be lower than 200MHz. For instance, if  $f_{IN} = 245.76\text{MHz}$  and the smallest possible SYSREF delay unit is desired, set DLC = 1 (DLC[1:0] = 00; also sets  $N_{DCB} = \div 1$ ). Then, set  $P_{DCB} = \div 24$  and  $M_{DCB} = \div 96$ . As a result,  $f_1 = f_2 = 10.24\text{MHz}$ ,  $f_{DCO} = 983.04\text{MHz}$ . This example configuration results in a delay unit of measured: 131ps. [Figure 5](#) shows more configuration examples.

**Calibration.** Calibration requires a valid DCB configuration with the DCO locking to an input frequency. Setting DCB\_CAL = 1 starts an automatic calibration. At the end, the DCB\_CAL bit will clear, the delay unit value is stored digitally and the DCO,  $P_{DCB}$ ,  $M_{DCB}$  and  $N_{DCB}$  frequency dividers turn off. The QREF\_r delay circuits now use the stored constant delay unit. The delay unit remains digitally stored until the next power cycle. The DCB calibration must run once as part of the device startup procedure and must be re-run after each input frequency or DCB configuration change.



**Verification.** Verify a successful calibration by reading the DAC\_CODE value.  $0 < \text{DAC\_CODE} < 32767$  indicates a successful calibration. If  $\text{DAC\_CODE} = 0$  or  $\text{DAC\_CODE} = 32767$ , the DCB calibration should be re-run with an alternative  $P_{\text{DCB}}$ ,  $M_{\text{DCB}}$  setting while maintaining the desired  $M_{\text{DCB}} \cdot N_{\text{DCB}}/P_{\text{DCB}}$  ratio for locking the DCO to the input frequency.

Figure 3. DCB Functional Diagram

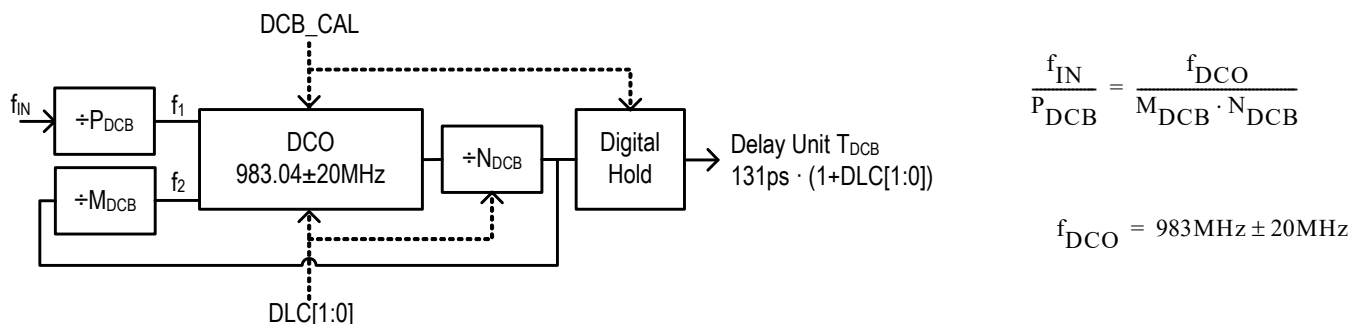

Table 4. DCB Delay Unit at  $f_{\text{DCO}} = 983.04 \text{MHz}$

$T_{\text{DCB}}$ Delay Unit (ps)	DLC		$N_{\text{DCB}}$
	DLC[1:0] Setting	Numeric Value	
131	00	1	1
262	01	2	2
393	10	3	3
524	11	4	4

Table 5. DCB Divider Configuration Examples<sup>[a]</sup>

$f_{\text{IN}}$ (MHz)	$T_{\text{DCB}}$ Delay Unit in ps	DLC	$P_{\text{DCB}}$	$M_{\text{DCB}}$
245.76	131	1	24	96
	262	2	24	48
	393	3	24	32
	524	4	24	24
491.52	131	1	48	96
	262	2	48	48
	393	3	48	32
	524	4	48	24
983.04	131	1	96	96
	262	2	96	48
	393	3	96	32
	524	4	96	24

[a]  $f_{\text{DCO}} = 983.04 \text{MHz}$ .

## QCLK to SYSREF Phase Alignment

To achieve an output phase alignment between the QCLK<sub>y</sub> clock and the QREF<sub>r</sub> SYSREF outputs, the CLK and REF input signals must be phase aligned or have a known, deterministic phase relationship. Figure 4 shows an example output phase alignment for aligned clock and SYREF inputs. The closest (smallest phase error) output alignment is achieved by setting the clock phase delay register  $\Phi_{QCLK\_y}$  to 0x00 (clock) and the SYSREF phase delay register  $\Phi_{QREF\_r}$  to 0x04. With a SYSREF phase delay setting of 0x03 or less, the QREF<sub>r</sub> output phase is in advance of the QCLK<sub>y</sub> phase, which is applicable in JESD204B application. Phase delay settings and propagation delays are independent on the clock and SYSREF frequencies. Table 6 shows recommended phase delay setting several device configurations.

Figure 4. QCLK to QREF Phase Alignment

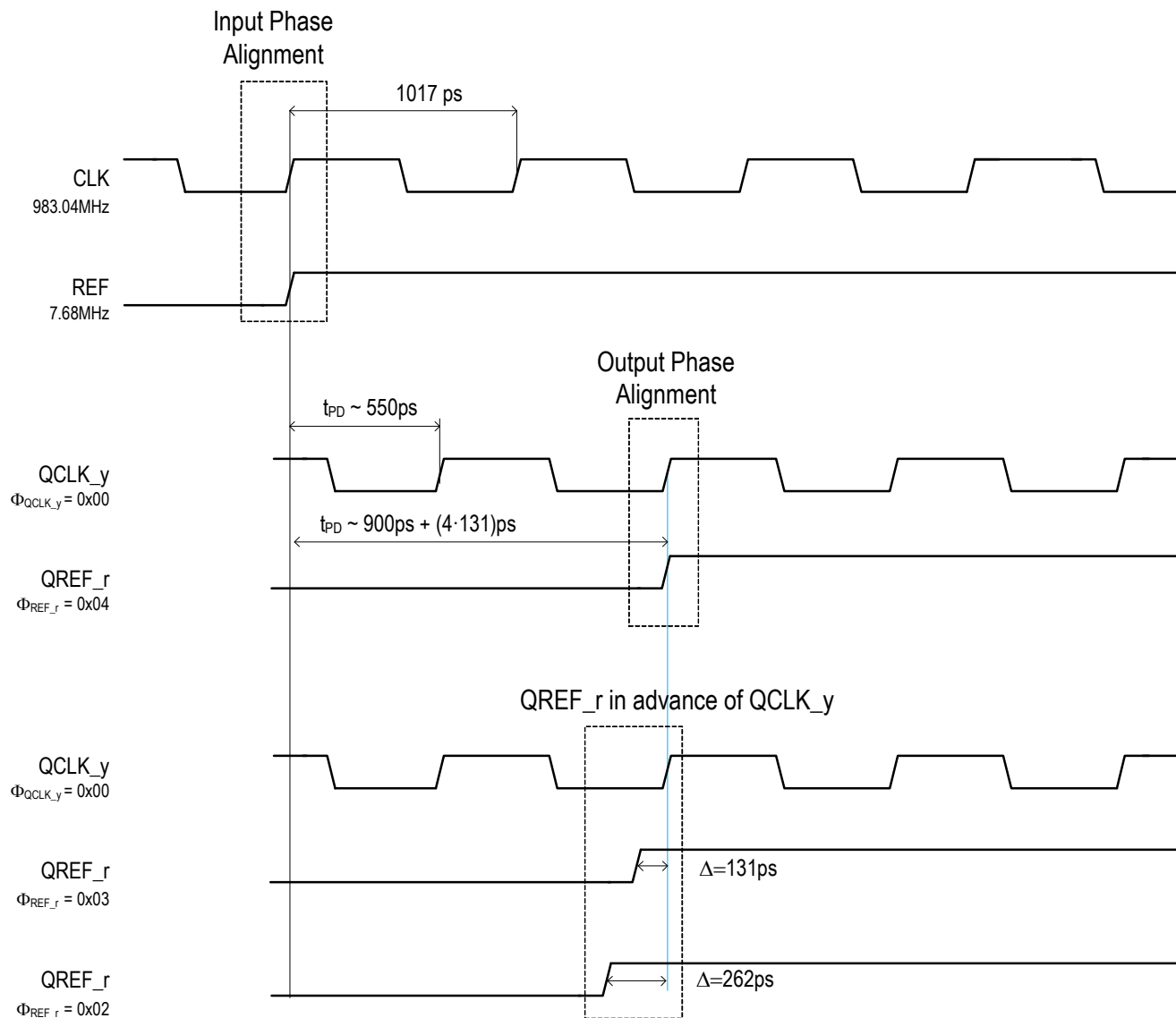

Table 6. Recommended Delay Settings for Closest Clock-SYSREF Output Phase Alignment<sup>[a]</sup>

Divider Configuration	$\Phi_{CLK\_y}$	$\Phi_{REF\_r}$
N = ÷1	0x00	0x04

[a] QCLK and QREF outputs are aligned on the incident edge.

## Differential Outputs

Table 7. Output Features

Output	Style	Ampl. <sup>[a]</sup>	Disable	Power Down	DC Bias	Termination
QCLK_y <sup>[b]</sup> , QREF_r <sup>[c]</sup> (Clock)	LVPECL	250-1000mV 4 steps	Yes	Yes	-	50Ω to V <sub>T</sub> <sup>[d]</sup>
	LVDS					100Ω differential <sup>[e][f]</sup>
QREF_r (SYSREF)	LVPECL	250-1000mV 4 steps	Yes	Yes	-	50Ω to V <sub>T</sub> <sup>[d]</sup>
	LVDS				Yes <sup>[g]</sup>	100Ω differential <sup>[e][f]</sup>

[a] Amplitudes are measured single-ended. Differential amplitudes supported are 500mV, 1000mV, 1500mV and 2000mV.

[b] y = A0, A1, A2, B0, B1, C0, C1 and D.

[c] r = A0, A1, A2, B0, B1, C0, C1 and D.

[d] V<sub>T</sub> = V<sub>DD\_V</sub> - 1.5V (250mV amplitude setting), V<sub>DD\_V</sub> - 1.75V (500mV amplitude setting), V<sub>DD\_V</sub> - 2.0V (750mV amplitude setting), V<sub>DD\_V</sub> - 2.25V (1000mV amplitude setting).

[e] AC coupling and DC coupling supported.

[f] See [Application Information](#) for output termination information.

[g] In JESD204B applications, it is recommended to use QREF\_r (SYSREF) outputs configured to LVDS and 500mV amplitude. AC-coupling and DC-coupling is supported.

Table 8. Individual Clock Output (QCLK\_y) Settings<sup>[a]</sup>

PD	STYLE	EN	A[1:0]	Output Power	Termination <sup>[b]</sup>	State	Amplitude (mV)
1	X	X	X	Off	100Ω differential (LVDS) or no termination	Off	X
0	0	0	XX	On	100Ω differential (LVDS)	Disable <sup>[c]</sup>	X
		1	00			Enable	250
			01				500
			10				750
			11				1000
	1	0	XX		50Ω to V <sub>T</sub> (LVPECL)	Disable	X
		1	00			Enable	250
			01				500
			10				750
			11				1000

[a] Applicable to clock outputs: QCLK\_y and QREF\_r outputs in clock mode (MUX\_r = 0).

[b] See [Application Information](#) for output termination information.

[c] Differential output is disabled in static low state: QCLK\_y = L, nQCLK\_y = H.

Table 9. Individual SYSREF Output (QREF\_r) Settings<sup>[a]</sup>

PD	STYLE	Enable	A[1:0]	nBIAS	Output Power	Termination <sup>[b]</sup>	State	Amplitude (mV)	
1	X	X	X	X	Off	100Ω differential or no termination	Off	X	
0	0	0	XX	0	On	100Ω differential (LVDS)	Disable <sup>[c]</sup>	X	
		1	00	0			Enabled	250	
			01	0			See Table 10	500	
				1					
			10	0			Enabled	750	
			11	0				1000	
	1	0	0	XX		0	50Ω to V <sub>T</sub> (LVPECL)	Disable	X
			1	00				Enable	250
		01		500					
		10		750					
		11		1000					

[a] Applicable QREF\_r outputs when configured as SYSREF output (MUX\_r = 1).

[b] See Section “Application Information” on page 41 for output termination information.

[c] Differential output is disabled in static low state: QCLK\_y = L, nQCLK\_y = H.

Table 10. QREF\_r Setting for JESD204B Applications

BIAS_TYPE	nBIAS_r	QREF_r Outputs (LVDS, 500mV amplitude)			Application
		Initial	Active Rising Edge on the REF Input	SYSREF Completed	
0	1	Static Low (QREF = L, nQREF_r = H)			QREF_r DC coupled
	0	Static Low (QREF = L, nQREF_r = H)	Start switching for the number of received SYSREF pulses	Released to static low (QREF = L, nQREF_r = H)	
1	0	Static LVDS crosspoint level (QREF = nQREF_r = VOS)	Start switching for the number of received SYSREF pulses	Released to static LVDS crosspoint level (QREF = n, QREF_r = VOS)	QREF_r AC coupled
	1	Static LVDS crosspoint level (QREF = n, QREF_r = VOS)			

## Device Startup, Reset, and Synchronization

At startup, an internal POR (power-on reset) resets the device and sets all register bits to its default value. In the default configuration the QCLK<sub>y</sub> and QREF<sub>r</sub> outputs are disabled at startup.

Recommended configuration sequence (in order):

1. (Optional) set the value of the CPOL register bit to define the SPI read mode, so that SPI settings can be validated by subsequent SPI read accesses.
2. Configure the channel circuits and the outputs to the desired values and configure the DCB:
  - Output source MUX<sub>r</sub>, output divider N<sub>A-D</sub>, clock delay  $\Phi_{A-D}$ , MUX-output style, amplitude and power down mode for QCLK<sub>y</sub> and QREF<sub>r</sub> outputs
  - For synchronization between multiple devices: Set N<sub>A-D</sub> = ÷1 and set BYP\_INIT = 1)
  - (Optional) the global BIAS\_TYPE bit and nBIAS<sub>r</sub> for each QREF<sub>r</sub> in preparation for JESD204B/SYSREF operation
  - Phase delay for  $\Phi_{REF_r}$  values for the QREF<sub>r</sub> outputs
  - Setup the DCB settings DLC, P<sub>DCB</sub> and M<sub>DCB</sub> as described in the paragraph *Configuration*, see [Delay Calibration Block \(DCB\)](#)
3. If not already applied: apply a valid input frequency to CLK. Set the PB\_CAL bit and the DCB\_CAL bit to start the calibration of the precision bias current circuit and the DCB calibration. Both bits will auto-clear. See paragraph *Configuration* in section [Delay Calibration Block \(DCB\)](#).
  - (Optional): verify the success of the DCB calibration by reading the DAC\_CODE value. See paragraph *Verification* in section [Delay Calibration Block \(DCB\)](#)
4. Set the initialization bit INIT\_CLK. This will initiate the N<sub>x</sub> divider and  $\Phi_{CLK_x}$  delay circuits and synchronize them to each other. The INIT\_CLK bit will self-clear.
5. At this point, the configuration of the registers 0x00 to 0x73 should be completed and the SPI transfer ended. Set nCS to high level.
6. In a separate SPI write access, enable the outputs as desired by accessing the output-enable registers 0x74 and 0x76.

Registers in the address range 0x78 to 0xFF should not be used. Do not write into any registers in the 0x78 to 0xFF range.

### Changing Frequency Dividers and Phase Delay Values

#### **Clock Frequency Divider and Delay**

Following procedure has to be applied for a change of a clock divider and phase delay value N<sub>A-D</sub>, and  $\Phi_{CLKA-D}$ :

1. (Optional) set the value of the CPOL register to define the SPI read mode, so that SPI settings can be validated by subsequent SPI read accesses.
2. (Optional) disable the outputs whose frequency divider or delay value is changed.
3. Configure the N<sub>A-D</sub> dividers and the delay circuits  $\Phi_{CLKA-D}$  to the desired new values.
  - For synchronization between multiple devices: Set N<sub>A-D</sub> = ÷1 and set BYP\_INIT = 1)
4. Set the initialization bit INIT\_CLK. This will initiate all divider and delay circuits and synchronize them to each other. The INIT\_CLK bit will self-clear. During this initialization step, all QCLK<sub>y</sub> and QREF<sub>r</sub> outputs are reset to the logic low state.
5. (Optional) Enable the outputs whose frequency divider was changed.

#### **SYSREF Delay**

Following procedure has to be applied for a change of any SYSREF phase delay value  $\Phi_{REF_r}$ :

1. (Optional) set the value of the CPOL register to define the SPI read mode, so that SPI settings can be validated by subsequent SPI read accesses.
2. Configure any delay circuits  $\Phi_{REF_r}$  to their desired new values. During configuration of  $\Phi_{REF_r}$  outputs are not stopped or interrupted.

## SPI Interface

The 8V79S680 has a 3-wire serial control port capable of responding as a slave in an SPI configuration to allow read and write access to any of the internal registers for device programming or read back. The SPI interface consists of the SCLK (clock), SDAT (serial data input and output), and nCS (chip select) pins. A data transfer consists of any integer multiple of 8 bits and is always initiated by the SPI master on the bus. Internal register data is organized in SPI bytes of 8 bits each. If nCS is at logic high, the SDAT data I/O is in high-impedance state and the SPI interface of the 8V79S680 is disabled. In a write operation, data on SDAT will be clocked in on the rising edge of SCLK. In a read operation, data on SDAT will be clocked out on the falling or rising edge of SCLK depending on the CPOL setting (CPOL = 0: output data changes on the falling edge, CPOL = 1: output data changes on the rising edge).

Starting a data transfer requires nCS to set and hold at logic low level during the entire transfer. Setting nCS = 0 will enable the SPI interface with SDAT in data input mode. The master must initiate the first 8-bit transfer. The first bit presented to the slave is the direction bit R/nW (1 = Read, 0 = Write) and the following seven bits are the address bits A[0:6] pointing to an internal register in the address space 0 to 127. Data is presented with the LSB (least significant bit) first.

**Read operation from an internal register:** a read operation starts with an 8 bit transfer from the master to the slave: SDAT is clocked on the rising edge of SCLK. The first bit is the direction bit R/nW which must be to 1 to indicate a read transfer, followed by 7 address bits A[0:6]. After the first 8 bits are clocked into SDAT, the SDAT I/O changes to output: the register content addressed by A[0:6] is loaded into the shift register and the next 8 SCLK falling clock cycles (if CPOL = 0) will then present the loaded register data on the SDAT output and transfer these to the master. Transfers must be completed by de-asserting nCS after any multiple 8 SCLK cycles. If nCS is de-asserted at any other number of SCLKs, the SPI behavior is undefined. SPI byte (8 bit) and back-to-back read transfers of multiple registers are supported with an address auto-increment. During multiple transfers, nCS must stay at logic low level and SDAT will present multiple registers (A), (A+1), (A+2), etc. with each 8 SCLK cycles. During SPI Read operations, the user may continue to hold nCS low and provide further bytes in a single block read.

**Write operation to a 8V79S680 register:** During a write transfer, a SPI master transfers one or more bytes of data into the internal registers of the 8V79S680. A write transfer starts by asserting nCS to low logic level. The first bit presented by the master must set the direction bit R/nW to 0 (Write) and the 7 address bits A[0:6] must contain the 7-bit register address. Bits D0 to D7 contain 8 bit of payload data, which is written into the register addressed by A[0:6] at the end of a 8-bit write transfer. Multiple, subsequent register transfers from the master to the slave are supported by holding nCS asserted at logic low level during write transfers. The 7 bit register address will auto-increment. Transfers must be completed by de-asserting nCS after any multiple 8 SCLK cycles. If nCS is de-asserted at any other number of SCLKs, the SPI behavior is undefined.

**End of transfer:** After de-asserting nCS, the SPI bus is available to transfers to other slaves on the SPI bus. See also the READ diagram (Figure 5) and WRITE diagram (Figure 6) displaying the transfer of two bytes of data from and into registers.

**Registers 0x78 to 0xFF:** Registers in the address range 0x78 to 0xFF should not be used. Do not write into any registers in the 0x78 to 0xFF range.

Figure 5. Logic Diagram: READ Data from 8V79S680 Registers for CPOL = 0 and CPOL = 1

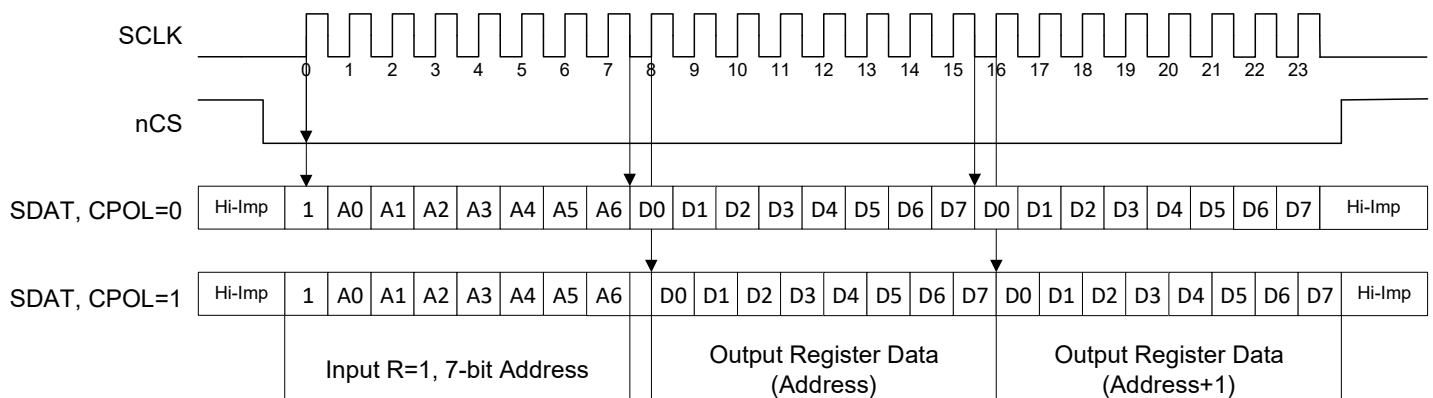

Figure 6. Logic Diagram WRITE Data into 8V79S680 Registers

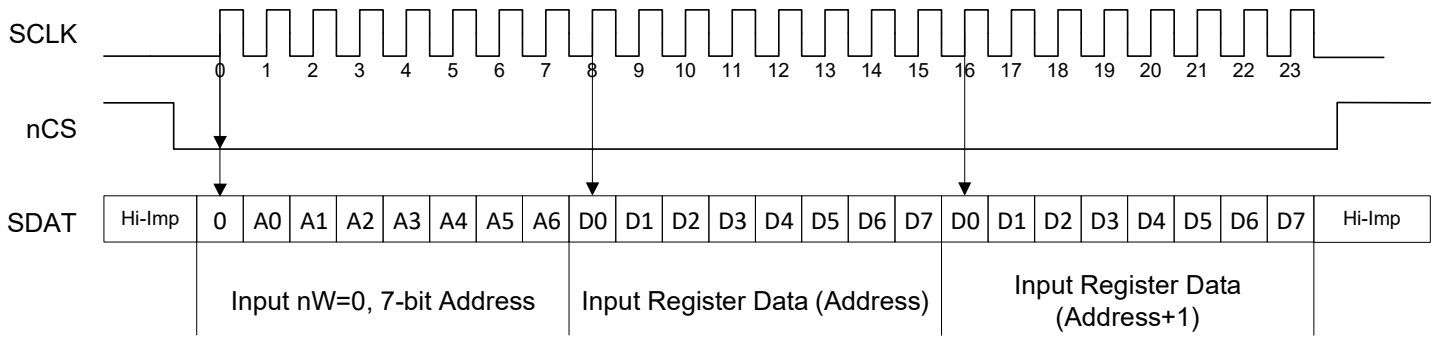
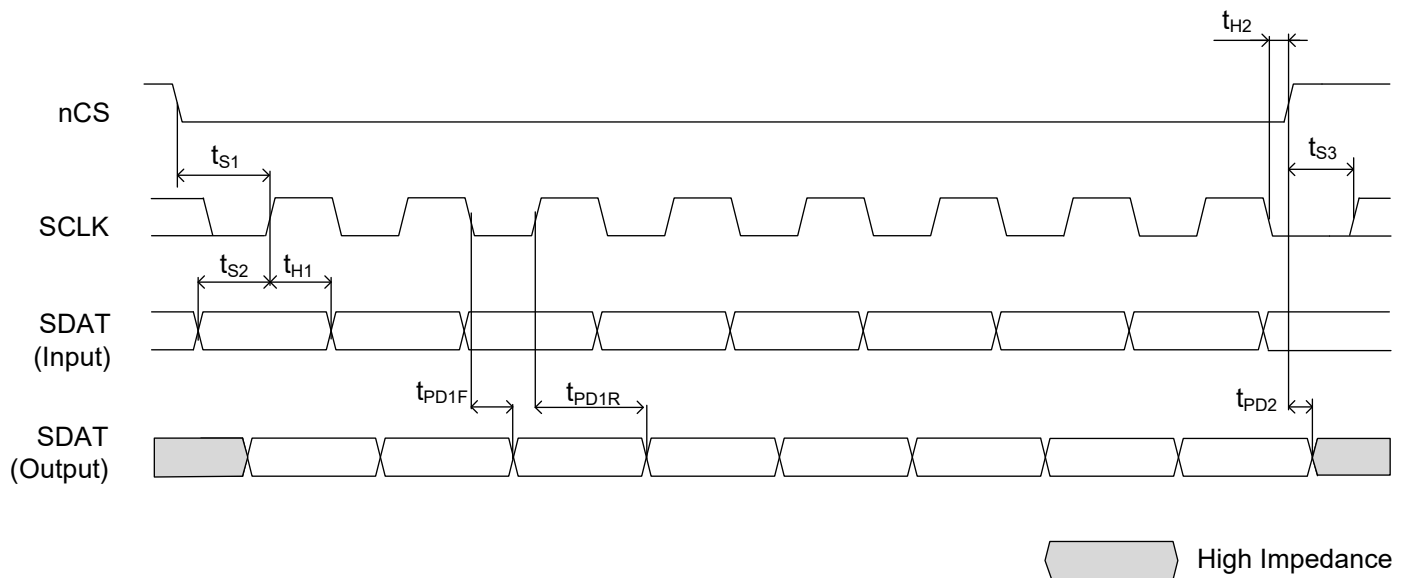

Table 11. SPI Read / Write Cycle Timing Parameters

Symbol	Parameter	Test Condition	Minimum	Maximum	Unit
$f_{SCLK}$	SCLK frequency			20	MHz
$t_{S1}$	Setup time, nCS (falling) to SCLK (rising)		5		ns
$t_{S2}$	Setup time, SDAT (input) to SCLK (rising)		5		ns
$t_{S3}$	Setup time, nCS (rising) to SCLK (rising)		5		ns
$t_{H1}$	Hold time, SCLK (rising) to SDAT (input)		5		ns
$t_{H2}$	Hold time, SCLK (falling) to nCS (rising)		5		ns
$t_{PD1F}$	Propagation delay, SCLK (falling) to SDAT	CPOL = 0		12	ns
$t_{PD1R}$	Propagation delay, SCLK (rising) to SDAT	CPOL = 1		12	ns
$t_{PD2}$	Propagation delay, nCS to SDAT disable			12	ns

Figure 7. SPI Timing Diagram



## Register Descriptions

This section contains a list of all addressable registers and a register description, sorted by function, followed for a detailed description of each bit field for each register. Several functional blocks with multiple instances in this device have individual registers controlling their settings, but since the registers have an identical format and bit meaning, they are described only once, but with an additional table to indicate their addresses and default values. All writable register fields will come up with a default values as indicated in the Factory Defaults column unless altered by values loaded from non-volatile storage during the initialization sequence.

Fixed read-only bits will have defaults as indicated in their specific register descriptions. Read-only status bits will reflect valid status of the conditions they are designed to monitor once the internal power-up reset has been released. Unused registers and bit positions are Reserved. Reserved bit fields will be unaffected by writes and are undefined on reads.

Table 12. Configuration Registers

Register Address	Register Description
0x00 - 0x17	Reserved
0x18 - 0x1B	SYSREF Control
0x1C - 0x1F	Reserved
0x20	Channel A, Output Divider
0x21	Channel A Delay $\Phi$ CLK_A
0x22	Channel A PD
0x23	Reserved
0x24	Output State QCLK_A0
0x25	Output State QCLK_A1
0x26	Output State QCLK_A2
0x27	Reserved
0x28	$\Phi$ REF_A0 Delay, MUX, PD
0x29	$\Phi$ REF_A1 Delay, MUX, PD
0x2A	$\Phi$ REF_A2 Delay, MUX, PD
0x2B	Reserved
0x2C	Output State QREF_A0
0x2D	Output State QREF_A1
0x2E	Output State QREF_A2
0x2F	Reserved
0x30	Channel B, Output Divider
0x31	Channel B Delay $\Phi$ CLK_B
0x32	Channel B PD
0x33	Reserved
0x34	Output State QCLK_B0
0x35	Output State QCLK_B1
0x36 - 0x37	Reserved
0x38	$\Phi$ REF_B0 Delay, MUX, PD
0x39	$\Phi$ REF_B1 Delay, MUX, PD



Table 12. Configuration Registers (Cont.)

Register Address	Register Description
0x3A-0x3B	Reserved
0x3C	Output State QREF_B0
0x3D	Output State QREF_B1
0x3E-0x3F	Reserved
0x40	Channel C, Output Divider
0x41	Channel C Delay $\Phi$ CLK_C
0x42	Channel C PD
0x43	Reserved
0x44	Output State QCLK_C0
0x45	Output State QCLK_C1
0x46-0x47	Reserved
0x48	$\Phi$ REF_C0 Delay, MUX, PD
0x49	$\Phi$ REF_C1 Delay, MUX, PD
0x4A-0x4B	Reserved
0x4C	Output State QREF_C0
0x4D	Output State QREF_C1
0x4E-0x4F	Reserved
0x50	Channel D, Output Divider
0x51	Channel D Delay $\Phi$ CLK_D
0x52	Channel D PD
0x53	Reserved
0x54	Output State QCLK_D
0x55-0x57	Reserved
0x58	$\Phi$ REF_D Delay, MUX, PD
0x59-0x5B	Reserved
0x5C	Output State QREF_D
0x5D-0x6B	Reserved
0x6C-0x6D	DAC_CODE
0x6E-0x6F	General Control
0x70	Reserved
0x71-0x73	General Control
0x74	Output State QCLK
0x75	Reserved
0x76	Output State QREF

Table 12. Configuration Registers (Cont.)

Register Address	Register Description
0x77	Reserved
0x78	Do not use
0x79	Do not use
0x7A	Do not use
0x7B	Do not use
0x7C-0x7D	Do not use
0x7E	Do not use
0x7F	Do not use
0x80-0xFF	Do not use

## Channel and Clock Output Registers

The content of the channel register and clock output registers set the clock divider, output style, amplitude, power down state, enable state and the clock phase delay.

Table 13. Channel and Clock Output Register Bit Field Locations

Bit Field Location								
Register Address	D7	D6	D5	D4	D3	D2	D1	D0
0x20 0x30 0x40 0x50	Reserved	Reserved	Reserved	Reserved	Reserved		N_A[2:0] N_B[2:0] N_C[2:0] N_D[2:0]	
0x21 0x31 0x41 0x51	$\Phi$ CLK_A[7:0] $\Phi$ CLK_B[7:0] $\Phi$ CLK_C[7:0] $\Phi$ CLK_D[7:0]							
0x22 0x32 0x42 0x52	PD_A PD_B PD_C PD_D	Reserved	Reserved	Reserved	Reserved	Reserved	Reserved	Reserved
0x24: QCLK_A0 0x25: QCLK_A1 0x26: QCLK_A2	PD_A0 PD_A1 PD_A2	Reserved	Reserved	STYLE_A0 STYLE_A1 STYLE_A2	A_A0[1:0] A_A1[1:0] A_A2[1:0]	Reserved		
0x34: QCLK_B0 0x35: QCLK_B1	PD_B0 PD_B1	Reserved	Reserved	STYLE_B0 STYLE_B1	A_B0[1:0] A_B1[1:0]	Reserved		
0x44: QCLK_C0 0x45: QCLK_C1	PD_C0 PD_C1	Reserved	Reserved	STYLE_C0 STYLE_C1	A_C0[1:0] A_C1[1:0]	Reserved		
0x54: QCLK_D	PD_D	Reserved	Reserved	STYLE_D	A_D[1:0]	Reserved		
0x74	EN_QCLK_A0	EN_QCLK_A1	EN_QCLK_A2	EN_QCLK_B0	EN_QCLK_B1	EN_QCLK_C0	EN_QCLK_C1	EN_QCLK_D

Table 14. Channel and Clock Output Register Descriptions<sup>[a]</sup>

Register Description				
Bit Field Name	Field Type	Default (Binary)	Description	
N <sub>x</sub> [2:0]	R/W	000 Value: ÷1	Output Frequency Divider N	
			N <sub>x</sub> [2:0]	Frequency Divider
			000	÷1 (Divider bypassed and powered-down)
			001	÷2
			010	÷4
			011	÷6
			100	÷8
			101	÷12
			110	÷16
			111	Not defined
			If N <sub>x</sub> [2:0] = 000 (÷1), set BYP_INIT = 1 to exclude the divider from initialization.	
PD <sub>x</sub>	R/W	0	0 = Channel <i>x</i> is powered up 1 = Channel <i>x</i> is powered down	
PD <sub>y</sub>	R/W	0	0 = Output QCLK <sub>y</sub> is powered up 1 = Output QCLK <sub>y</sub> is powered down	
ΦCLK <sub>x</sub> [7:0]	R/W	0000 0000 Value: 0ns	CLK <sub>x</sub> Phase Delay	
			ΦCLK <sub>x</sub> [7:0]	Phase Delay in units of the input period: ΦCLK <sub>x</sub> [7:0] ÷ f <sub>IN</sub> (256 steps).
			0000 0000	0ps
			0000 0001	1 ÷ f <sub>IN</sub>
			1111 1111	255 ÷ f <sub>IN</sub>
A <sub>y</sub> [1:0]	R/W	00 Value: 250mV	QCLK <sub>y</sub> Output Amplitude	
			Setting for STYLE = 0 (LVDS) Termination: 100Ω across	Setting for STYLE = 1 (LVPECL) Termination: 50Ω to VT
			A[1:0] = 00: 250mV	
			A[1:0] = 01: 500mV	
		A[1:0] = 10: 750mV		
		A[1:0] = 11: 1000mV		
STYLE <sub>y</sub>		0 Value: LVDS	QCLK <sub>y</sub> Output Format: 0 = Output is LVDS (requires LVDS 100Ω output termination) 1 = Output is LVPECL (requires LVPECL 50Ω output termination to the specified recommended termination voltage)	
EN <sub>y</sub>		0 Value: disabled	QCLK <sub>y</sub> Output Enable: 0 = QCLK <sub>y</sub> Output is disabled at the logic low state 1 = QCLK <sub>y</sub> Output is enabled	

 [a] *x* = A, B, C, D; *y* = A0, A1, A2, B0, B1, C0, C1, D.

## QREF Output State Registers

The content of the QREF output registers selects the source signal of the QREF outputs, set the phase delay, the style, the amplitude, the power state, the enable state and the output bias.

Table 15. QREF Output State Register Bit Field Locations<sup>[a]</sup>

Bit Field Location								
Register Address	D7	D6	D5	D4	D3	D2	D1	D0
0x28: QREF_A0 0x29: QREF_A1 0x2A: QREF_A2	Reserved	Reserved	Reserved	MUX_A0 MUX_A1 MUX_A2	ΦREF_A0[2:0] ΦREF_A1[2:0] ΦREF_A2[2:0]			Reserved
0x38: QREF_B0 0x39: QREF_B1	Reserved	Reserved	Reserved	MUX_B0 MUX_B1	ΦREF_B0[2:0] ΦREF_B1[2:0]			Reserved
0x48: QREF_C0 0x49: QREF_C1	Reserved	Reserved	Reserved	MUX_C0 MUX_C1	ΦREF_C0[2:0] ΦREF_C1[2:0]			Reserved
0x58: QREF_D	Reserved	Reserved	Reserved	MUX_D	ΦREF_D[2:0]			Reserved
0x2C: QREF_A0 0x2D: QREF_A1 0x2E: QREF_A2	PD_A0 PD_A1 PD_A2	Reserved	nBIAS_A0 nBIAS_A1 nBIAS_A2	STYLE_A0 STYLE_A1 STYLE_A2	A_A0[1:0] A_A1[1:0] A_A2[1:0]		Reserved	Reserved
0x3C: QREF_B0 0x3D: QREF_B1	PD_B0 PD_B1	Reserved	nBIAS_B0 nBIAS_B1	STYLE_B0 STYLE_B1	A_B0[1:0] A_B1[1:0]		Reserved	Reserved
0x4C: QREF_C0 0x4D: QREF_C1	PD_C0 PD_C1	Reserved	nBIAS_C0 nBIAS_C1	STYLE_C0 STYLE_C1	A_C0[1:0] A_C1[1:0]		Reserved	Reserved
0x5C: QREF_D	PD_D	Reserved	nBIAS_D	STYLE_D	A_D[1:0]		Reserved	Reserved
0x76	EN_QREF_A0	EN_QREF_A1	EN_QREF_A2	EN_QREF_B0	EN_QREF_B1	EN_QREF_C0	EN_QREF_C1	EN_QCLK_D

[a] r = A0, A1, A2, B0, B1, C0, C1, D.

Table 16. QREF Output State Register Descriptions<sup>[a]</sup>

Register Description							
Bit Field Name	Field Type	Default (Binary)	Description				
MUX <sub>r</sub>	R/W	1 Value: QREF = SYSREF	0 = QREF <sub>r</sub> output signal source is the channel's clock signal 1 = QREF <sub>r</sub> output signal source is the centrally generated SYSREF signal				
ΦREF <sub>r</sub> [2:0]	R/W	000 Value: 0ps	SYSREF Phase Delay:  QREF <sub>r</sub> delay = ΦREF <sub>r</sub> [2:0] · T <sub>DCB</sub> . Delay values for f <sub>DCO</sub> = 983.04MHz. Delay values are a function of T <sub>DCB</sub> .				
			ΦREF <sub>r</sub> [2:0]	QREF <sub>r</sub> delay in ps for a DLC[1:0] setting of:			
				00	01	10	11
			000	0	0	0	0
			001	131	262	393	524
			010	262	524	786	1048
			...	...	...	...	...
111	917	1834	2751	3668			
nBIAS <sub>r</sub>	R/W	0	QREF <sub>r</sub> Output Bias Voltage: Individual QREF <sub>r</sub> output LVDS output bias operation. Not applicable to QREF <sub>r</sub> outputs set to LVPECL mode.  0 = Normal operation 1 = Output is biased to the LVDS cross-point voltage if BIAS <sub>TYPE</sub> (register 0x19, bit 7) is set to 1. Bit has no effect if BIAS <sub>TYPE</sub> = 0. Output bias = 1 requires AC coupling and LVDS style on the corresponding output.				
			BIAS <sub>TYPE</sub>	nBIAS <sub>r</sub>	QREF <sub>r</sub> output operation if set to LVDS.		
			0	0	QREF <sub>r</sub> outputs are initially logic low (QREF <sub>r</sub> = L, nQREF <sub>r</sub> = H) and will start switching on the first rising edge of the REF input. Use in DC-coupled applications.		
			0	1	Disabled with static low/high levels. During a SYSREF event, the output remains at static low levels (QREF <sub>r</sub> = L, nQREF <sub>r</sub> = H).		
			1	0	Both QREF <sub>r</sub> and nQREF <sub>r</sub> outputs are initially set to the LVDS crosspoint level (VOS) and will start switching on the first rising edge of the REF input. Use in AC-coupled applications.		
1	1	Output is statically set to the LVDS crosspoint voltage. During a SYSREF event, the output remains at the LVDS crosspoint level (VOS).					

Table 16. QREF Output State Register Descriptions<sup>[a]</sup>

Register Description				
Bit Field Name	Field Type	Default (Binary)	Description	
A <sub>r</sub> [1:0]	R/W	00  Value: 250mV	QREF <sub>r</sub> Output Amplitude	
			Setting for STYLE = 0 (LVDS) Termination: 100Ω across	Setting for STYLE = 1 (LVPECL) Termination: 50Ω to VT
			A[1:0] = 00: 250mV A[1:0] = 01: 500mV A[1:0] = 10: 750mV A[1:0] = 11: 1000mV	
PD <sub>r</sub>	R/W	0  Value: Powered up	QREF <sub>r</sub> Output Power Down: 0 = Output is powered up 1 = Output is powered down. STYLE, EN and A[1:0] settings have no effect	
STYLE <sub>r</sub>	R/W	0  Value: LVDS	QREF <sub>r</sub> Output Format: 0 = Output is LVDS (requires LVDS 100Ω output termination) 1 = Output is LVPECL (requires LVPECL 50Ω output termination of to the specified recommended termination voltage)	
EN <sub>r</sub>	R/W	0  Value: Disabled	QREF <sub>r</sub> Output Enable: 0 = Output is disabled at the logic low state 1 = Output is enabled	

[a] r = A0, A1, A2, B0, B1, C0, C1, D.

## SYSREF Control Registers

Table 17. SYSREF Control Register Bit Field Locations

Bit Field Location								
Register Address	D7	D6	D5	D4	D3	D2	D1	D0
0x18	PD_S	Reserved	Reserved	Reserved	Reserved	Reserved	Reserved	Reserved
0x19	BIAS_TYPE	DLC[1:0]		Reserved	Reserved	Reserved	Reserved	M_DCB[8]
0x1A	M_DCB[7:0]							
0x1B	Reserved	P_DCB[6:0]						

Table 18. SYSREF Control Register Descriptions

Register Description					
Bit Field Name	Field Type	Default (Binary)	Description		
PD_S	R/W	1 Value: Powered down	SYSREF Global Power-down: 0 = SYSREF functional blocks are powered-up 1 = SYSREF functional blocks are powered-down		
BIAS_TYPE	R/W	1	SYSREF Output Voltage Bias: Global to all QREF_r outputs bit to control the LVDS output operation. Not applicable to QREF_r outputs set to LVPECL mode.		
			BIAS_TYPE	nBIAS_r	QREF_r output operation if set to LVDS.
			0	0	QREF_r outputs are initially logic low (QREF_r = L, nQREF_r = H) and will start switching on the first rising edge of the REF input. Use in DC-coupled applications.
			0	1	Disabled with static low/high levels. During a SYSREF event, the output remains at static low levels (QREF_r = L, nQREF_r = H).
			1	0	Both QREF_r and nQREF_r outputs are initially set to the LVDS crosspoint level (VOS) and will start switching on the first rising edge of the REF input. Use in AC-coupled applications.
1	1	Output is statically set to the LVDS crosspoint voltage. During a SYSREF event, the output remains at the LVDS crosspoint level (VOS).			



Table 18. SYSREF Control Register Descriptions

Register Description				
Bit Field Name	Field Type	Default (Binary)	Description	
DLC[1:0]	R/W	00 Value: 131ps	Delay Unit Multiplier: Effective delay unit for the SYSREF outputs is $(1 + \text{DLC}[1:0]) \div (8 \cdot f_{\text{DCO}})$ .	
			DLC[1:0]	Effective SYSREF Delay Unit for $f_{\text{DCO}} = 983.04\text{MHz}$
			00	131ps
			01	262ps
			10	393ps
			11	524ps
M_DCB[8:0]	R/W	0 0000 1000 Value: 8	Delay Calibration Block (DCB) DCO feedback divider. Set in conjunction with $f_{\text{IN}}$ and P_DCB to achieve a DCO frequency of $983.04 \pm 20\text{MHz}$ : $f_{\text{DCO}} = f_{\text{IN}} \div P_{\text{DCB}} \cdot M_{\text{DCB}}$ .	
P_DCB[6:0]	R/W	000 1000 Value: 8	Delay Calibration Block (DCB) DCO input divider. Set in conjunction with $f_{\text{IN}}$ and M_DCB to achieve DCO frequency of $983.04 \pm 20\text{MHz}$ : $f_{\text{DCO}} = f_{\text{IN}} \div P_{\text{DCB}} \cdot M_{\text{DCB}}$ . DCO phase detector frequency should not exceed 200MHz.	

## General Control Registers

Table 19. General Control Register Bit Field Locations

Bit Field Location								
Register Address	D7	D6	D5	D4	D3	D2	D1	D0
0x6C	Reserved	DAC_CODE[14:8]						
0x6D	DAC_CODE[7:0]							
0x6E	Reserved	Reserved	Reserved	Reserved	Reserved	Reserved	Reserved	Reserved
0x6F	Reserved	Reserved	PBIAS[5:0]					
0x70	Reserved	Reserved	Reserved	Reserved	Reserved	Reserved	Reserved	Reserved
0x71	INIT_CLK	Reserved	Reserved	Reserved	Reserved	Reserved	Reserved	Reserved
0x72	DCB_CAL	Reserved	Reserved	Reserved	Reserved	Reserved	Reserved	Reserved
0x73	PB_CAL	Reserved	Reserved	Reserved	Reserved	Reserved	BYP_INIT	CPOL

Table 20. General Control Register Descriptions

Register Description			
Bit Field Name	Field Type	Default (Binary)	Description
DAC_CODE[14:0]	R only	X	DAC_CODE is the result of the internal DCB calibration routine. Trigger calibration by setting the DCB_CAL bit.
PBIAS[5:0]	R only	X	BIAS level.
INIT_CLK	W only Auto-Clear	X	Clock divider and phase clock phase delay initialization. Set INIT_CLK = 1 to initialize N <sub>x</sub> divider and $\Phi$ CLK <sub>x</sub> clock phase delay functions. Required as part of the startup procedure and after each change of a clock divider or clock phase delay value.
PB_CAL	W only Auto-Clear	X	Precision Bias Calibration: Set PB_CAL to 1 starts the auto-calibration of an internal precision bias current source. The bias current is used as reference for outputs configured as LVDS. This bit will auto-clear after the calibration completed. Required to set as part of the startup procedure.

Table 20. General Control Register Descriptions

Register Description			
Bit Field Name	Field Type	Default (Binary)	Description
DCB_CAL	W only Auto-Clear	X	DCB Calibration: Setting this bit to 1 will begin the auto-calibration of the DCB. The DCB provides a reference for the SYSREF delay circuits. This bit will auto-clear. This bit should be set as part of the startup procedure. The result of the calibration routine is stored in the DAC_CODE register.
BYP_INIT	R/W	1	Bypass Clock Frequency Divide Initializer: 0 = The clock dividers $N_{A-D}$ are initialized when INIT_CLK = 1 1 = The clock dividers $N_{A-D}$ are excluded from the initialization. This setting is only applicable to $N_{A-D}$ dividers = $\neq 1$ and should be used to achieve output phase alignment across multiple devices.
CPOL	R/W	0	SPI Read Operation SCLK Polarity: 0 = Data bits on MISO are output at the falling edge of SCLK edge. 1 = Data bits on MISO are output at the rising edge of SCLK edge.

## Electrical Characteristics

### Absolute Maximum Ratings

The absolute maximum ratings are stress ratings only. Stresses greater than those listed below can cause permanent damage to the device. Functional operation of the 8V79S680 at absolute maximum ratings is not implied. Exposure to absolute maximum rating conditions may affect device reliability.

Table 21. Absolute Maximum Ratings

Item	Rating
Supply Voltage, $V_{DD\_V}$	3.6V
Inputs	-0.5V to $V_{DD\_V} + 0.5V$
Outputs, $V_O$ (LVCMOS)	-0.5V to $V_{DD\_V} + 0.5V$
Outputs, $I_O$ (LVPECL) Continuous Current Surge Current	50mA 100mA
Outputs, $I_O$ (LVDS) Continuous Current Surge Current	50mA 100mA
Input termination current, $I_{VT}$	$\pm 35mA$
Operating Junction Temperature, $T_J$	125°C
Storage Temperature, $T_{STG}$	-65°C to 150°C
ESD - Human Body Model <sup>[a]</sup>	2000V
ESD - Charged Device Model <sup>[a]</sup>	500V

[a] According to JEDEC JS-001-2012/JESD22-C101.

### Pin Characteristics

Table 22. Pin Characteristics,  $V_{DD\_V} = 3.3V \pm 5\%$ ,  $T_A = -40^\circ C$  to  $+85^\circ C$

Symbol	Parameter	Test Conditions	Minimum	Typical	Maximum	Units
$C_{IN}$	Input Capacitance			2	4	pF
$R_{PD}$	Input Pull-Down Resistor	SCLK		51		k $\Omega$
$R_{PU}$	Input Pull-Up Resistor	nCS		51		k $\Omega$
$R_{OUT}$	LVCMOS Output Impedance	SDAT (when output)		25		$\Omega$

## DC Characteristics

Table 23. Power Supply DC Characteristics,  $V_{DD\_V} = 3.3V \pm 5\%$ ,  $T_A = -40^\circ\text{C}$  to  $+85^\circ\text{C}$ <sup>[a]</sup>

Symbol	Parameter	Test Conditions	Minimum	Typical	Maximum	Units
$V_{DD\_V}$	Core Supply Voltage		3.135	3.3	3.465	V
$I_{DD}(\text{Total})$	Power Supply Current	QCLK_y and QREF_r set to LVDS, 750mV amplitude, terminated 100Ω, Nx dividers set to ÷1			705	mA

[a] Electrical parameters are guaranteed over the specified ambient operating temperature range, which is established when the device is mounted in a test socket with maintained transverse airflow greater than 500 lpm. The device will meet specifications after thermal equilibrium has been reached under these conditions.

Table 24. Typical Power Supply Current Characteristics,  $V_{DD\_V} = 3.3V$ ,  $T_A = 25^\circ\text{C}$ <sup>[a]</sup>

Symbol	Supply Pin Current		Test Case						Unit
			1	2	3	4	5	6	
	QCLK_y	Style	LVPECL	LVPECL	LVDS	LVDS	LVDS	LVDS	
		State	On	On	On	On	On	On	
		Amplitude	500	750	500	500	750	750	mV
	QREF_r	Style	LVDS	LVDS	LVDS	LVDS	LVDS	LVDS	
		State	Off	Off	Off	On	On	On	
		Amplitude	–	–	–	250	250	500	mV
$I_{DD\_CA}$	Current through $V_{DD\_QCLKA}$ pin(s)		109.6	127.3	73.0	73.0	95.0	95.0	mA
$I_{DD\_RA01}$	Current through $V_{DD\_QREFA01}$ pin(s)		1.5	1.5	1.5	27.0	26.9	43.0	mA
$I_{DD\_RA2}$	Current through $V_{DD\_QREFA2}$ pin(s)		0.8	0.7	0.8	13.5	13.5	20.5	mA
$I_{DD\_CB}$	Current through $V_{DD\_QCLKB}$ pin(s)		72.4	83.6	48.0	48.0	63.0	63.0	mA
$I_{DD\_RB}$	Current through $V_{DD\_QREFB}$ pin(s)		1.5	1.5	1.5	27.0	27.0	43.0	mA
$I_{DD\_CC}$	Current through $V_{DD\_QCLKC}$ pin(s)		76.2	87.7	49.3	49.0	63.0	63.0	mA
$I_{DD\_RC}$	Current through $V_{DD\_QREFC}$ pin(s)		1.5	1.5	1.5	27.0	27.0	43.0	mA
$I_{DD\_CD}$	Current through $V_{DD\_QCLKD}$ pin(s)		43.8	49.6	29.5	29.5	36.4	36.4	mA
$I_{DD\_RD}$	Current through $V_{DD\_QREFD}$ pin(s)		0.8	0.8	0.8	13.6	13.6	20.7	mA
$I_{DD\_CLK}$	Current through $V_{DD\_CLK}$ pin(s)		40.3	40.2	39.8	40.2	40.2	40.1	mA
$I_{DD\_REF}$	Current through $V_{DD\_REF}$ pin(s)		9.8	9.8	9.7	52.8	53.5	54.2	mA
$I_{DD\_SPI}$	Current through $V_{DD\_SPI}$ pin(s)		12.8	13.1	12.9	13.3	13.4	13.4	mA
PTOT	Total Device Power Consumption		1.223	1.377	0.885	1.365	1.559	1.766	W
PTOT, SYS	Total System Power Consumption <sup>[b]</sup>		1.403	1.557	0.885	1.365	1.559	1.766	W

[a]  $f_{IN}$  (input) = 983.04MHz,  $f_{SYSREF} = 7.68\text{MHz}$ . Supply current is independent on the output frequency. QCLK\_y outputs terminated according to amplitude settings. QREF\_r outputs unterminated when SYSREF is turned off.

[b] Includes total device power consumption and the power dissipated in external output termination components.

Table 25. LVCMOS (JESD8-7A, 1.8V) DC Characteristics,  $V_{DD\_V} = 3.3V \pm 5\%$ ,  $T_A = -40^\circ\text{C}$  to  $+85^\circ\text{C}$ <sup>[a]</sup> <sup>[b]</sup>

Symbol	Parameter		Test Conditions	Minimum	Typical	Maximum	Units
$V_{T+}$	Positive-going input threshold voltage	SCLK, nCS, SDAT		0.660		1.365	V
$V_{T-}$	Negative-going input threshold voltage			0.495		1.170	V
$V_H$	Hysteresis Voltage		$V_{T+} - V_{T-}$	0.165		0.780	V
$I_{IH}$	Input High Current		$V_{DD\_V} = 3.3V, V_{IN} = 1.8V$			150	$\mu\text{A}$
$I_{IL}$	Input Low Current		$V_{DD\_V} = 3.465V, V_{IN} = 0V$	-150			$\mu\text{A}$
$V_{OH}$	Output High Voltage	SDAT (when output)	$I_{OH} = -4\text{mA}$	1.4			V
$V_{OL}$	Output Low Voltage		$I_{OL} = 4\text{mA}$			0.45	V

[a] Electrical parameters are guaranteed over the specified ambient operating temperature range, which is established when the device is mounted in a test socket with maintained transverse airflow greater than 500 lfpm. The device will meet specifications after thermal equilibrium has been reached under these conditions.

[b] Table is valid for the SPI interface pins nCS, SCLK and SDAT. SPI inputs have hysteresis.

Table 26. Differential Input DC Characteristics,  $V_{DD\_V} = 3.3V \pm 5\%$ ,  $T_A = -40^\circ\text{C}$  to  $+85^\circ\text{C}$ <sup>[a]</sup>

Symbol	Parameter		Test Conditions	Minimum	Typical	Maximum	Units
$R_{IN}$	Input Resistance	CLK, nCLK REF, nREF		43.5	50	56.5	$\Omega$
$R_{IN\_DIFF}$	Differential Input Resistance	CLK, nCLK REF, nREF		87	100	113	$\Omega$

[a] Electrical parameters are guaranteed over the specified ambient operating temperature range, which is established when the device is mounted in a test socket with maintained transverse airflow greater than 500 lfpm. The device will meet specifications after thermal equilibrium has been reached under these conditions.

Table 27. LVPECL DC Characteristics (QCLK\_y, QREF\_r, STYLE = 1),  $V_{DD\_V} = 3.3V \pm 5\%$ ,  $T_A = -40^\circ C$  to  $+85^\circ C$ <sup>[a]</sup>

Symbol	Parameter	Test Conditions	Minimum	Typical	Maximum	Units
$V_{OH}$	Output High Voltage <sup>[b]</sup>	Any Amplitude Setting	$V_{DD\_V} - 1.10$	$V_{DD\_V} - 0.85$	$V_{DD\_V} - 0.65$	V
$V_{OL}$	Output Low Voltage <sup>[b]</sup>	250mV Amplitude Setting	$V_{DD\_V} - 1.30$	$V_{DD\_V} - 1.15$	$V_{DD\_V} - 1.10$	V
		500mV Amplitude Setting	$V_{DD\_V} - 1.55$	$V_{DD\_V} - 1.40$	$V_{DD\_V} - 1.25$	V
		750mV Amplitude Setting	$V_{DD\_V} - 1.80$	$V_{DD\_V} - 1.65$	$V_{DD\_V} - 1.50$	V
		1000mV Amplitude Setting	$V_{DD\_V} - 2.10$	$V_{DD\_V} - 1.90$	$V_{DD\_V} - 1.75$	V

[a] Electrical parameters are guaranteed over the specified ambient operating temperature range, which is established when the device is mounted in a test socket with maintained transverse airflow greater than 500 lfpm. The device will meet specifications after thermal equilibrium has been reached under these conditions.

[b] Outputs terminated with  $50\Omega$  to  $V_{DD\_V} - 1.5V$  (250mV amplitude setting),  $V_{DD\_V} - 1.75V$  (500mV amplitude setting),  $V_{DD\_V} - 2.0V$  (750mV amplitude setting),  $V_{DD\_V} - 2.25V$  (1000mV amplitude setting).  $V_{DD\_V}$ .

Table 28. LVDS DC Characteristics (QCLK\_y, QREF\_r, STYLE = 0),  $V_{DD\_V} = 3.3V \pm 5\%$ ,  $T_A = -40^\circ C$  to  $+85^\circ C$ <sup>[a]</sup> [b]

Symbol	Parameter	Test Conditions	Minimum	Typical	Maximum	Units
$V_{OS}$	Offset Voltage <sup>[c]</sup>	250mV Amplitude Setting	2.00	2.40	2.80	V
		500mV Amplitude Setting	1.80	2.23	2.60	V
		750mV Amplitude Setting	1.70	2.08	2.50	V
		1000mV Amplitude Setting	1.55	1.93	2.35	V
$\Delta V_{OS}$	$V_{OS}$ Magnitude Change			50	mV	

[a] Electrical parameters are guaranteed over the specified ambient operating temperature range, which is established when the device is mounted in a test socket with maintained transverse airflow greater than 500 lfpm. The device will meet specifications after thermal equilibrium has been reached under these conditions.

[b] Outputs are terminated  $100\Omega$ .

[c]  $V_{OS}$  changes with  $V_{DD\_V}$ .

## AC Characteristics

Table 29. AC Characteristics,  $V_{DD\_V} = 3.3V \pm 5\%$ ,  $T_A = -40^\circ C$  to  $+85^\circ C$ <sup>[a]</sup>

Symbol	Parameter		Test Conditions	Minimum	Typical	Maximum	Units
$f_{IN}$	Input Frequency <sup>[b]</sup>	CLK, nCLK		0	983.04	3000	MHz
		REF, nREF		0		100	MHz
$V_{IN}$	Input Voltage Amplitude <sup>[c]</sup>	CLK, nCLK REF, nREF		0.15		1.2	V
$V_{DIFF\_IN}$	Differential Input Voltage Amplitude <sup>[c] [d]</sup>	CLK, nCLK REF, nREF		0.3		2.4	V
$V_{CMR}$	Common Mode Input Voltage			1.125		$V_{DD\_V} - (V_{IN} / 2)$	V
$f_{OUT}$	Output Frequency		QCLK, QREF (Clock), $N = \div 1$ to $\div 16$	0	983.04	$3000 \div N$	MHz
			QREF (SYSREF)	0		100	MHz
odc	Output Duty Cycle <sup>[e]</sup>		QCLK, QREF (Clock), $f_{CLK} \leq 2500MHz$	45	50	55	%
			QCLK, QREF (Clock), $2500MHz < f_{CLK} \leq 3000MHz$	43	50	57	%
			QREF (SYSREF at 7.68MHz)	45	50	55	%
$t_R / t_F$	Output Rise/Fall Time		QCLK, QREF (LVPECL), 20% to 80%			250	ps
			QCLK, QREF (LVDS), 20% to 80%			250	ps
			QREF (SYSREF, LVDS), 20% to 80%			250	ps
$V_{O(PP)}^{[f]}$	LVPECL Output Voltage Swing, Peak-to-peak, 983.04MHz		250mV Amplitude Setting	260	300	320	mV
			500mV Amplitude Setting	430	532	650	mV
			750mV Amplitude Setting	675	785	920	mV
			1000mV Amplitude Setting	950	981	1150	mV
	LVPECL Differential Output Voltage Swing, Peak-to-peak, 983.04MHz		250mV Amplitude Setting	520	600	640	mV
			500mV Amplitude Setting	860	1064	1300	mV
			750mV Amplitude Setting	1350	1570	1840	mV
			1000mV Amplitude Setting	1900	1962	2300	mV
$V_{O(PP)}^{[g]}$	LVDS Output Voltage Swing, Peak-to-peak, 983.04MHz		250mV Amplitude Setting	190	240	280	mV
			500mV Amplitude Setting	400	500	570	mV
			750mV Amplitude Setting	625	750	840	mV
			1000mV Amplitude Setting	800	1000	1160	mV
	LVDS Differential Output Voltage Swing, Peak-to-peak, 983.04MHz		250mV Amplitude Setting	380	480	560	mV
			500mV Amplitude Setting	800	1000	1140	mV
			750mV Amplitude Setting	1250	1500	1680	mV
			1000mV Amplitude Setting	1600	2000	2320	mV



Table 29. AC Characteristics,  $V_{DD\_V} = 3.3V \pm 5\%$ ,  $T_A = -40^\circ C$  to  $+85^\circ C$ <sup>[a]</sup>

Symbol	Parameter	Test Conditions	Minimum	Typical	Maximum	Units
/sk(o)	Output Skew; NOTE <sup>[h]</sup> [i] All delays set to 0	QCLK (same N divider) <sup>[j]</sup>			100	ps
		QCLK (any N divider, incident rising edge)			100	ps
		QREF (Clock)			100	ps
		QREF (SYSREF)			100	ps
		QCLK to QREF (QREF as clock output) <sup>[j]</sup>			190	ps
/sk(pp)	Part-to-part skew All delays set to 0	CLK to any QCLK <sup>[j]</sup>			375	ps
		REF to any QREF			375	ps
t <sub>PD</sub>	Propagation Delay <sup>j</sup> All delay circuits set to 0	CLK to QCLK <sub>y</sub> <sup>[j]</sup>	300		850	ps
		CLK to QCLK <sub>y</sub> (divider bypass) <sup>[j]</sup>	300	550	850	ps
		REF to QREF <sub>r</sub> ( $\Phi_{REF\_y} = 0$ )	700	900	1050	ps
$\Delta t_{PD}$	Propagation delay variation between the clock input and any QCLK <sub>y</sub> output	CLK to QCLK <sub>y</sub> <sup>[j]</sup>	-100		+100	ps
	Output isolation between any QCLK-QCLK and QREF-QREF outputs	f <sub>QCLK<sub>y</sub></sub> = 983.04MHz <sup>[k]</sup>	60			dB
		f <sub>QCLK<sub>y</sub></sub> = 491.52MHz <sup>[k]</sup>	65			dB
		f <sub>QCLK<sub>y</sub></sub> = 245.76MHz <sup>[k]</sup>	70			dB
	Output isolation between any QREF/QCLK outputs	f <sub>QCLK<sub>y</sub></sub> = 983.04MHz, 491.52MHz, 245.76MHz; f <sub>QREF<sub>r</sub></sub> = 7.68MHz	50			dB

[a] Electrical parameters are guaranteed over the specified ambient operating temperature range, which is established when the device is mounted in a test socket with maintained transverse airflow greater than 500 lfm. The device will meet specifications after thermal equilibrium has been reached under these conditions.

[b] The CLK, nCLK input supports 0Hz if the applied static signal has a minimum amplitude as specified by  $V_{IN}$ ,  $V_{DIFF\_IN}$ . For REF, nREF interfaces at 0Hz, See “CLK, nCLK and REF, nREF Interface in JESD204B Applications”.

[c]  $V_{IL}$  should not be less than -0.3V and  $V_{IH}$  should not be greater than  $V_{DD\_V}$ .

[d] Common Mode Input Voltage is defined as the cross-point voltage.

[e] Input = 50% duty cycle.

[f] LVPECL outputs terminated with 50Ω to  $V_T = V_{DD\_V} - 1.5V$  (250mV amplitude setting),  $V_{DD\_V} - 1.75V$  (500mV amplitude setting),  $V_{DD\_V} - 2.0V$  (750mV amplitude setting),  $V_{DD\_V} - 2.25V$  (1000mV amplitude setting).

[g] LVDS outputs terminated 100Ω across Q, nQ.

[h] This parameter is defined in accordance with JEDEC standard 65.

[i] Defined as skew between outputs at the same supply voltage and with equal load conditions. Measured at the differential cross points

[j] All frequency dividers N are in ÷1, ÷2, ÷4 or ÷8; output amplitude setting 750mV.

[k] Output amplitudes set to 500mV or 750mV.

Table 30. DCB and Phase Delay Characteristics,  $V_{DD_V} = 3.3V \pm 5\%$ ,  $T_A = -40^\circ C$  to  $+85^\circ C$  [a]

Symbol	Parameter	Test Conditions		Minimum	Typical	Maximum	Units
$f_{DCO}$	DCO Lock Range			963.04	983.04	1003.04	MHz
$T_{DCB}$	$\Phi REF_r$ Delay Unit Range	$f_{DCO} = 983.04MHz$	DLC = 1 (DLC[1:0] = 00)	115	131	150	ps
			DLC = 2 (DLC[1:0] = 01)	230	262	300	ps
			DLC = 3 (DLC[1:0] = 10)	345	393	450	ps
			DLC = 4 (DLC[1:0] = 11)	460	524	600	ps
		$f_{DCO} = 963.04MHz$ (min DCO frequency)	DLC = 1 (DLC[1:0] = 00)	113	134	152	ps
			DLC = 2 (DLC[1:0] = 01)	226	268	304	ps
			DLC = 3 (DLC[1:0] = 10)	339	402	456	ps
			DLC = 4 (DLC[1:0] = 11)	452	536	608	ps
		$f_{DCO} = 1003.04MHz$ (max DCO frequency)	DLC = 1 (DLC[1:0] = 00)	112	128	142	ps
			DLC = 2 (DLC[1:0] = 01)	224	256	284	ps
			DLC = 3 (DLC[1:0] = 10)	336	384	426	ps
			DLC = 4 (DLC[1:0] = 11)	448	512	568	ps
$T_{IN}^{[b]}$	$\Phi CLK_x$ Delay Unit	$f_{IN} = 983.04MHz$		1017		ps	
$f_1, f_2$	DCO Phase Detector Frequency					200	MHz
$\Delta t_D$	Delay unit variation	$\Phi REF_r$ delay unit variation (deviation from nominal, DLC[1:0] = 00)		-30	0	+30	ps
		$\Phi CLK_y$ delay unit variation (deviation from nominal)		-20	0	+20	ps

[a] Electrical parameters are guaranteed over the specified ambient operating temperature range, which is established when the device is mounted in a test socket with maintained transverse airflow greater than 500 lfm. The device will meet specifications after thermal equilibrium has been reached under these conditions.

[b]  $\Phi CLK_x$  clock channel delay unit is equal to  $1 \div f_{IN}$ .

## Additive Clock Phase Noise Characteristics

The 8V79S680 is a buffer device, it does not filter the phase noise on the input clock source. Phase noise caused by noise sources within the device can add to the input signal noise, resulting in an increased noise on the outputs (additive phase noise). Phase noise from within the part is not correlated with the noise on the input, therefore the root-sum-square method must be used to calculate the output phase noise:  $\Phi_{OUT}^2 = \Phi_{IN}^2 + \Phi_{DEVICE}^2$ . As a consequence, at frequency offsets where the input phase noise  $\Phi_{IN}$  is higher than internal noise sources, the effect of additive phase noise is not measurable.

Simulations of the device phase noise performance are done with an ideal input source, however, simulation models may not account for all possible internal noise sources. Table 31 shows the simulation results for the 8V79S680 buffer with an ideal input source. Table 33 shows output phase noise measured with a low-noise input source, with one column for the measured data and a second column which de-rates the measured data by a factor to model the process variation. Table 33 shows that the input phase noise is the dominating factor in the measured data up to an offset of 100kHz. Above 100kHz, the noise floor of the device dominates the characteristics.

Table 31. Additive Clock Phase Noise Characteristics (Simulation<sup>[a]</sup>),  $V_{DD_V} = 3.3V \pm 5\%$ <sup>[b]</sup>

Symbol	Parameter		Test Conditions	25°C	85°C, Worst Case	Units
$\Phi_N(1k)$	QCLK_y Phase Noise	245.76MHz	1kHz offset from Carrier	-146.2	-145.5	dBc/Hz
$\Phi_N(10k)$			10kHz offset from Carrier	-156.6	-155.3	dBc/Hz
$\Phi_N(100k)$			100kHz offset from Carrier	-161.9	-159.6	dBc/Hz
$\Phi_N(1M)$			1MHz offset from Carrier	-162.4	-160.5	dBc/Hz
$\Phi_N(10M)$			10MHz offset from Carrier and Noise Floor	-162.4	-160.5	dBc/Hz
$\Phi_N(1k)$		491.52MHz	1kHz offset from Carrier	-141.6	-141.6	dBc/Hz
$\Phi_N(10k)$			10kHz offset from Carrier	-152.7	-151.6	dBc/Hz
$\Phi_N(100k)$			100kHz offset from Carrier	-159.2	-157.0	dBc/Hz
$\Phi_N(1M)$			1MHz offset from Carrier	-159.8	-158.1	dBc/Hz
$\Phi_N(10M)$			10MHz offset from Carrier and Noise Floor	-159.9	-158.2	dBc/Hz
$\Phi_N(1k)$		983.04MHz	1kHz offset from Carrier	-134.5	-132.0	dBc/Hz
$\Phi_N(10k)$			10kHz offset from Carrier	-141.4	-141.8	dBc/Hz
$\Phi_N(100k)$			100kHz offset from Carrier	-155.8	-152.6	dBc/Hz
$\Phi_N(1M)$			1MHz offset from Carrier	-157.2	-155.3	dBc/Hz
$\Phi_N(10M)$			10MHz offset from Carrier and Noise Floor	-157.2	-155.8	dBc/Hz

[a] Ideal input signal: rectangular clock signal with a slew rate of 5V/ns and without phase noise.

[b] Phase noise and spurious specifications apply for device operation with QREF\_r outputs inactive (no SYSREF pulses generated). Phase noise specifications are applicable for all outputs active, Nx not equal, process and voltage variations included.

Figure 8. Additive Clock Phase Noise Characteristics (85°C, Worst Case Simulation Model)

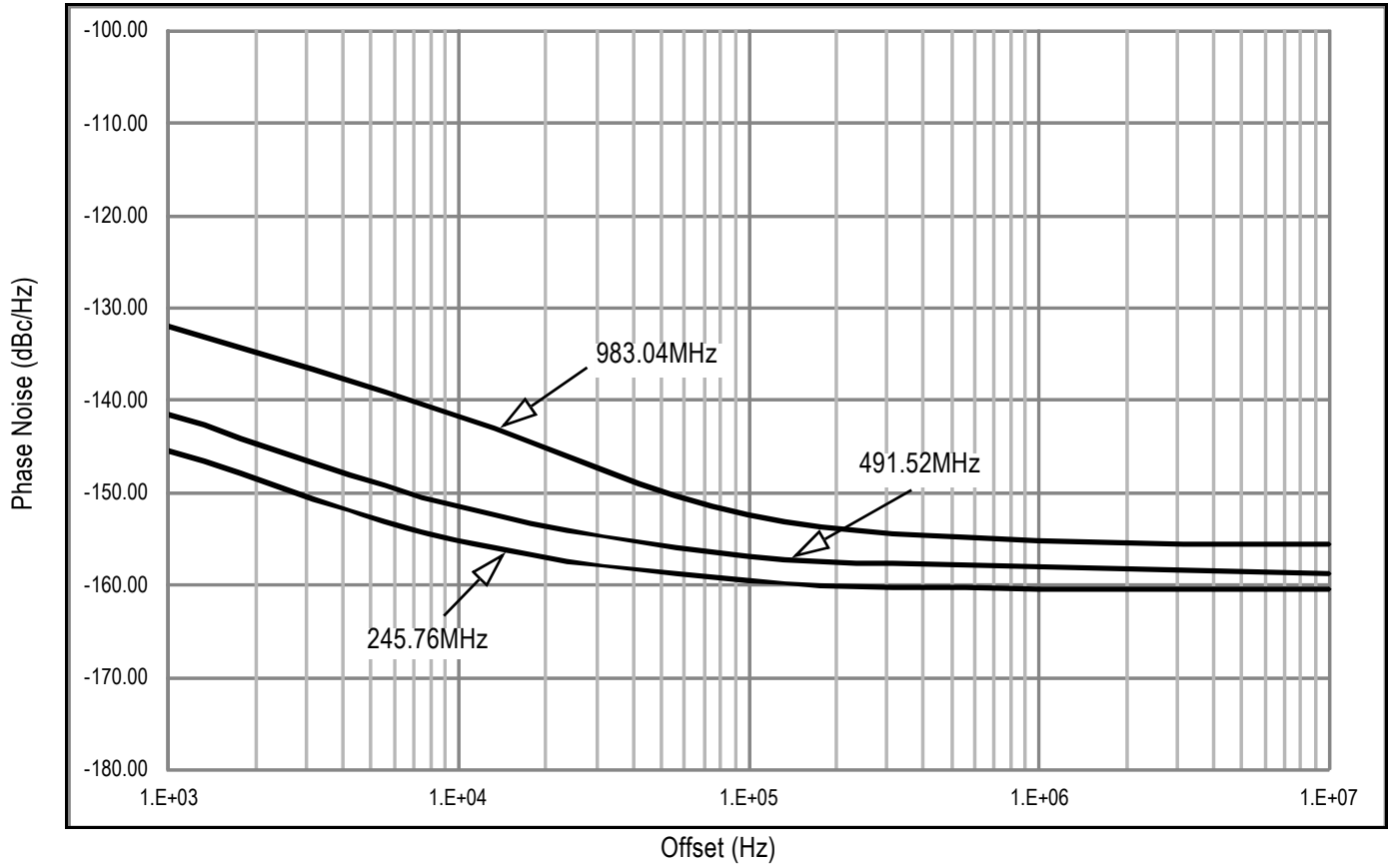

Table 32. Additive Clock Phase Noise Characteristics (Measured),  $V_{DD_V} = 3.3V \pm 5\%$ ,  $T_A = -40^\circ C$  to  $+85^\circ C$  [a][b]

Symbol	Parameter		Test Conditions	Measured <sup>[c]</sup>	De-Rated <sup>[d]</sup>	Units
$\Phi_N(1k)$	QCLK Phase Noise	245.76MHz	1kHz offset from Carrier	-141.4	-137.2	dBc/Hz
$\Phi_N(10k)$			10kHz offset from Carrier	-151.7	-149.5	dBc/Hz
$\Phi_N(100k)$			100kHz offset from Carrier	-157.8	-155.5	dBc/Hz
$\Phi_N(1M)$			1MHz offset from Carrier	-158.6	-156.2	dBc/Hz
$\Phi_N(10M)$			10MHz offset from Carrier and Noise Floor	-158.8	-156.3	dBc/Hz
$\Phi_N(1k)$		491.52MHz	1kHz offset from Carrier	-135.3	-128.4	dBc/Hz
$\Phi_N(10k)$			10kHz offset from Carrier	-145.8	-140.5	dBc/Hz
$\Phi_N(100k)$			100kHz offset from Carrier	-154.2	-149.5	dBc/Hz
$\Phi_N(1M)$			1MHz offset from Carrier	-157.2	-155.4	dBc/Hz
$\Phi_N(10M)$			10MHz offset from Carrier and Noise Floor	-157.6	-156.3	dBc/Hz
$\Phi_N(1k)$		983.04MHz	1kHz offset from Carrier	-131.3	-125.7	dBc/Hz
$\Phi_N(10k)$			10kHz offset from Carrier	-141.2	-138.5	dBc/Hz
$\Phi_N(100k)$			100kHz offset from Carrier	-149.6	-146.5	dBc/Hz
$\Phi_N(1M)$			1MHz offset from Carrier	-154.5	-152.2	dBc/Hz
$\Phi_N(10M)$			10MHz offset from Carrier and Noise Floor	-155.3	-152.5	dBc/Hz
$j_{jit}(\emptyset)$	Clock RMS Phase Jitter (Random)		Integration Range: 1kHz - 61.44MHz		100	fs
			Integration Range: 12kHz - 20MHz		100	fs

[a] Phase noise and spurious specifications apply for device operation with QREF\_r outputs inactive (no SYSREF pulses generated). Phase noise specifications are applicable for all outputs active, Nx not equal.

[b] Electrical parameters are guaranteed over the specified ambient operating temperature range, which is established when the device is mounted in a test socket with maintained transverse airflow greater than 500 lfm. The device will meet specifications after thermal equilibrium has been reached under these conditions.

[c] Measured results at the max. temperature of 85°C using an input source with a phase noise characteristics of:

- 245.76MHz: -143.7dBc/Hz (1kHz offset), -152.5dBc/Hz (10kHz), -160.8dBc/Hz (100kHz), -172.6dBc/Hz (1MHz), -179.5dBc/Hz (10MHz).
- 491.52MHz: -137.7dBc/Hz (1kHz offset), -147.4dBc/Hz (10kHz), -156.1dBc/Hz (100kHz), -167.6dBc/Hz (1MHz), -170.1dBc/Hz (10MHz).
- 983.04MHz: -132.5dBc/Hz (1kHz offset), -141.4dBc/Hz (10kHz), -149.9dBc/Hz (100kHz), -161.4dBc/Hz (1MHz), -164.2dBc/Hz (10MHz).

[d] De-rating factor applied to the characterized data at 85°C to account for worst-case process variation.

Figure 9. Additive Clock Phase Noise Characteristics (Measured),  $f_{CLK} = 245.76\text{MHz}$

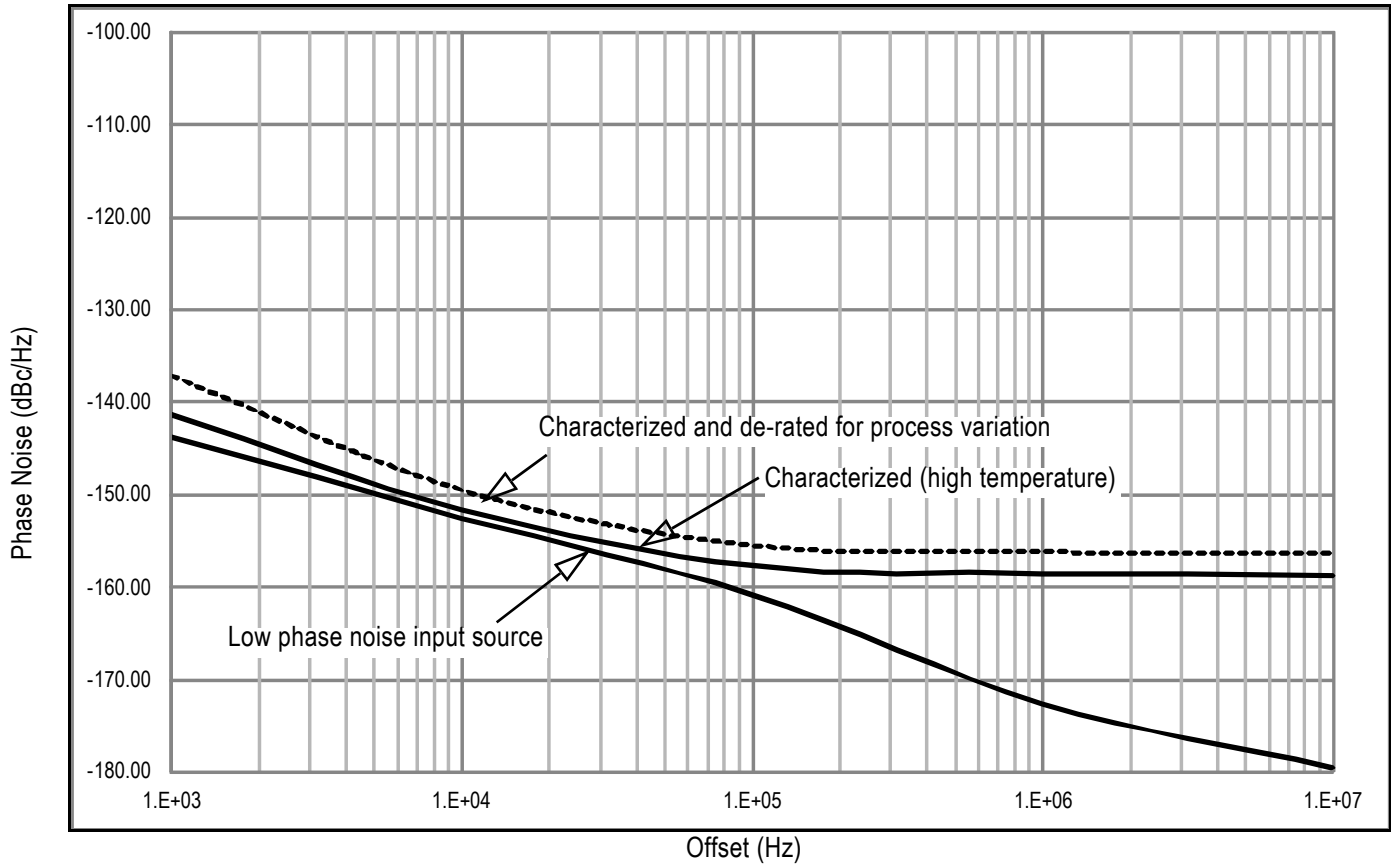

Figure 10. Additive Clock Phase Noise Characteristics (Measured),  $f_{CLK} = 491.52\text{MHz}$

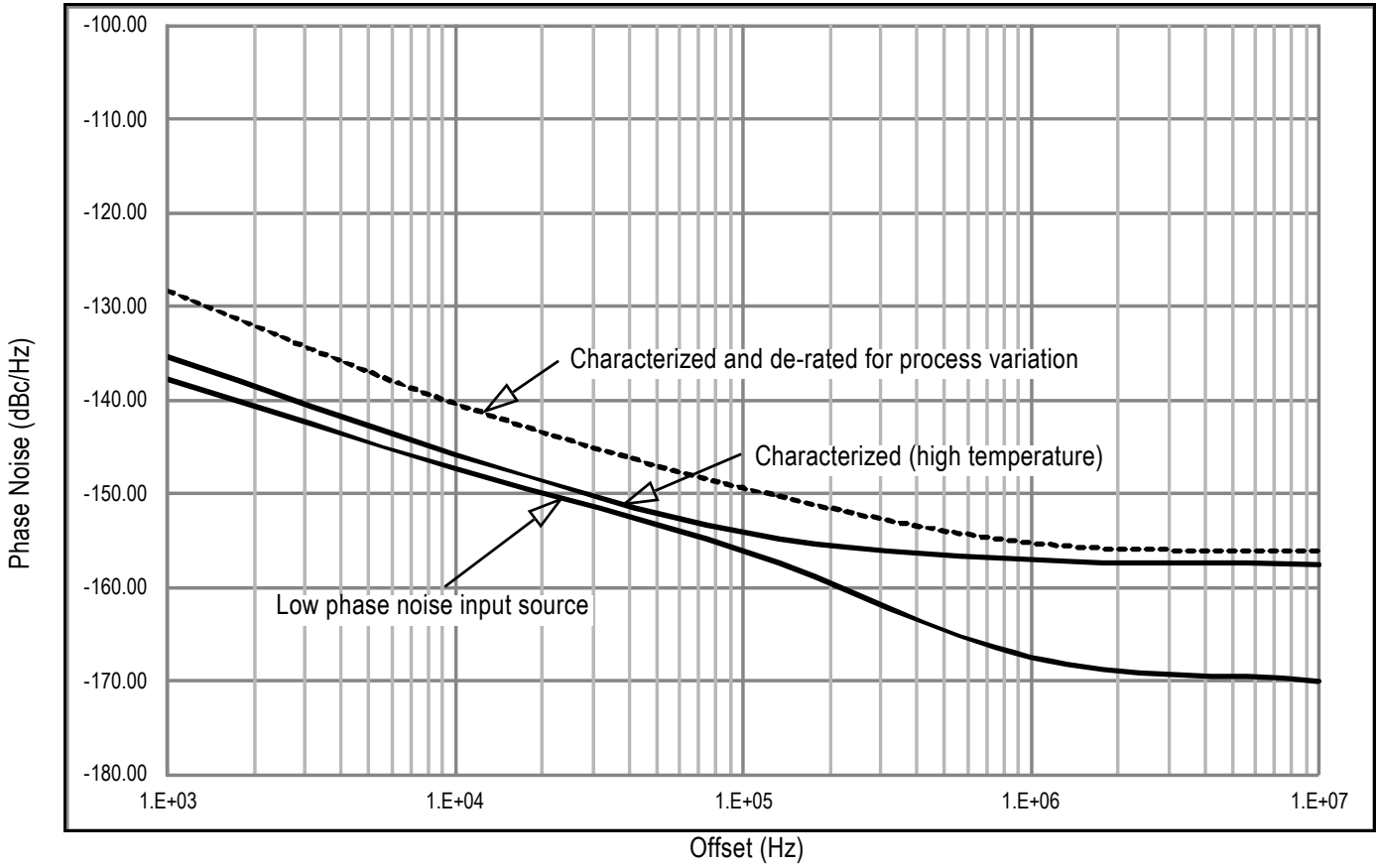
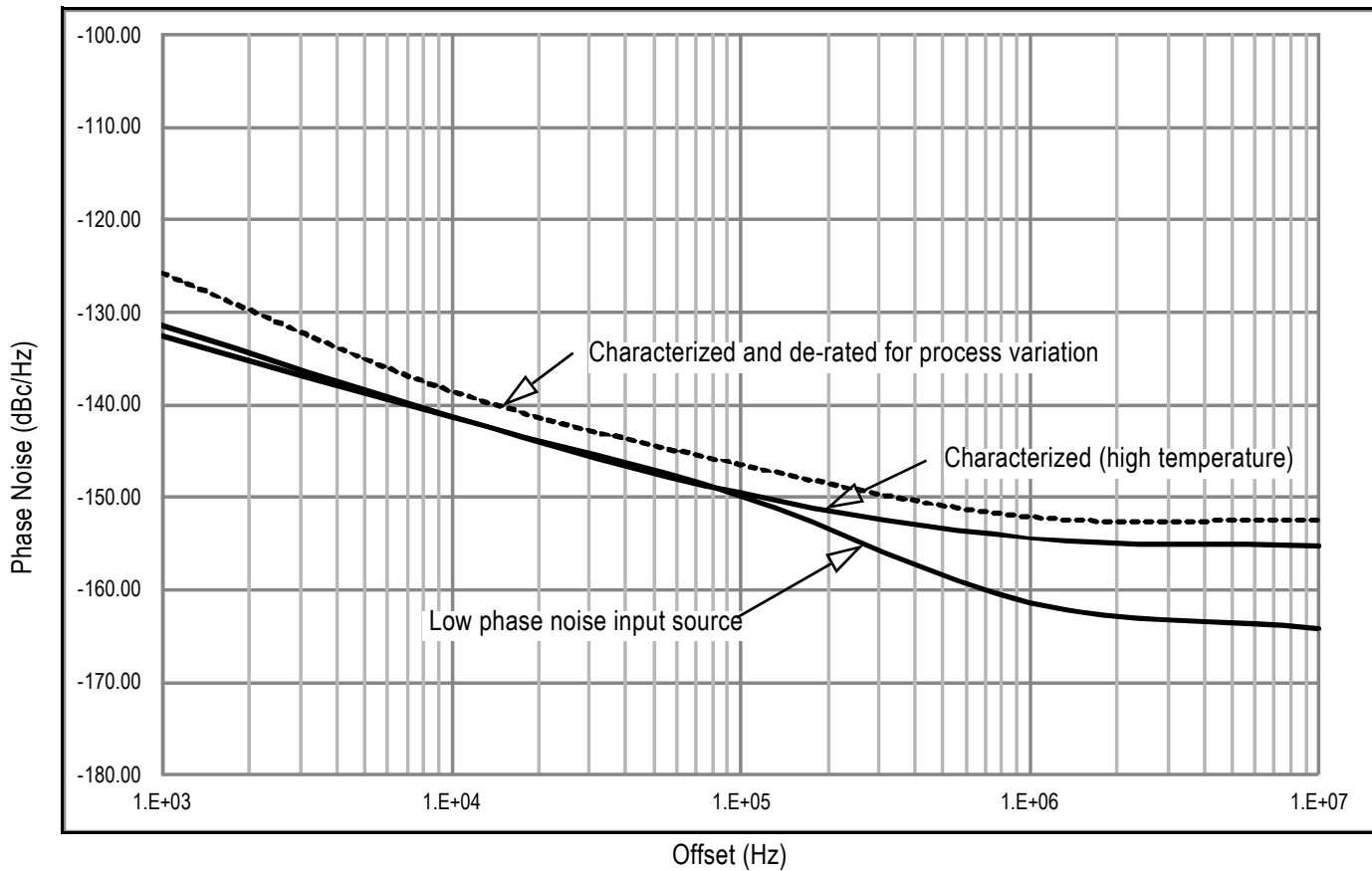

Figure 11. Additive Clock Phase Noise Characteristics (Measured),  $f_{CLK} = 983.04\text{MHz}$



Symbol	Parameter	Test Conditions	Typical	Unit	
$\Phi_N(1k)$	QREF_r Phase Noise	15.36MHz <sup>[a]</sup>	1kHz offset from Carrier	-146	dBc/Hz
$\Phi_N(10k)$			10kHz offset from Carrier	-152.5	dBc/Hz
$\Phi_N(100k)$			100kHz offset from Carrier	-156	dBc/Hz
$\Phi_N(1M)$			1MHz offset from Carrier	-156	dBc/Hz
$\Phi_N(1k)$		30.72MHz	1kHz offset from Carrier	-147.5	dBc/Hz
$\Phi_N(10k)$			10kHz offset from Carrier	-153.5	dBc/Hz
$\Phi_N(100k)$			100kHz offset from Carrier	-155.5	dBc/Hz
$\Phi_N(1M)$			1MHz offset from Carrier	-155.5	dBc/Hz

[a] Measured results with DLC[1:0] = 00 and  $\Phi_{REF\_r} = 3$ .



## Application Information

### Termination for QCLK\_y, QREF\_r LVDS Outputs (STYLE = 0)

Figure 12 shows an example termination for the QCLK\_y, QREF\_r LVDS outputs. In this example, the characteristic transmission line impedance is  $50\Omega$ . The termination resistor R ( $100\Omega$ ) is matched to the line impedance. The termination resistor must be placed at the line end. No external termination resistor is required if R is an internal part of the receiver circuit. The LVDS termination in Figure 12 is applicable for any output amplitude setting specified in Table 7.

Figure 12. LVDS (STYLE = 0) Output Termination

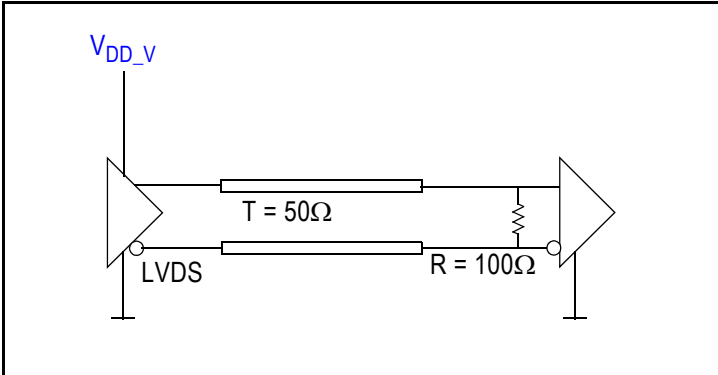

### AC Termination for QCLK\_y, QREF\_r LVDS Outputs (STYLE = 0)

Figure 13 and Figure 14 show example AC terminations for the QCLK\_y, QREF\_r LVDS outputs. In the examples, the characteristic transmission line impedance is  $50\Omega$ . In Figure 13, the termination resistor R ( $100\Omega$ ) is placed at the line end. No external termination resistor is required if R is an internal part of the receiver circuit, which is shown in Figure 14. The LVDS terminations in both Figure 13 and Figure 14 are applicable for any output amplitude setting specified in Table 7. The receiver input should be re-biased according to its common mode range specifications.

Figure 13. LVDS (STYLE = 0) AC Output Termination

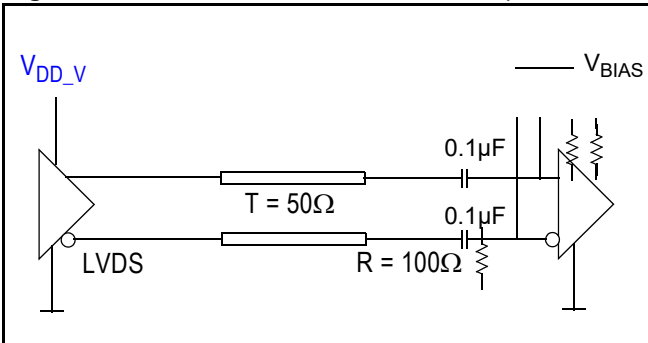
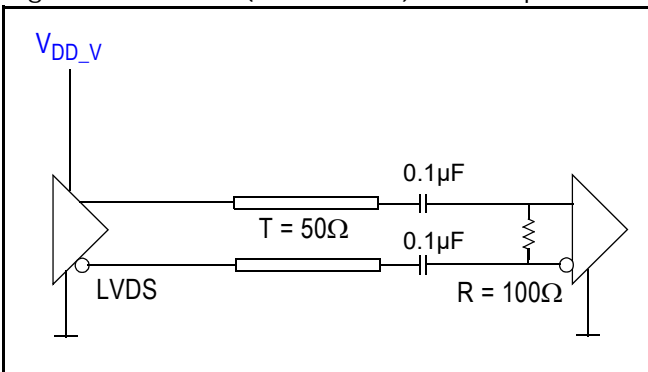

Figure 14. LVDS (STYLE = 0) AC Output Termination



## Termination for QCLK\_y, QREF\_r LVPECL Outputs (STYLE = 1)

Figure 15 shows an example termination for the QCLK\_y, QREF\_r LVPECL outputs. In this example, the characteristic transmission line impedance is 50Ω. The R1 (50Ω) and R2 (50Ω) resistors are matched load terminations. The output is terminated to the termination voltage  $V_T$ . The  $V_T$  must be set according to the output amplitude setting defined in Table 7. The termination resistors must be placed close at the line end.

Figure 15. LVPECL (STYLE = 1) Output Termination

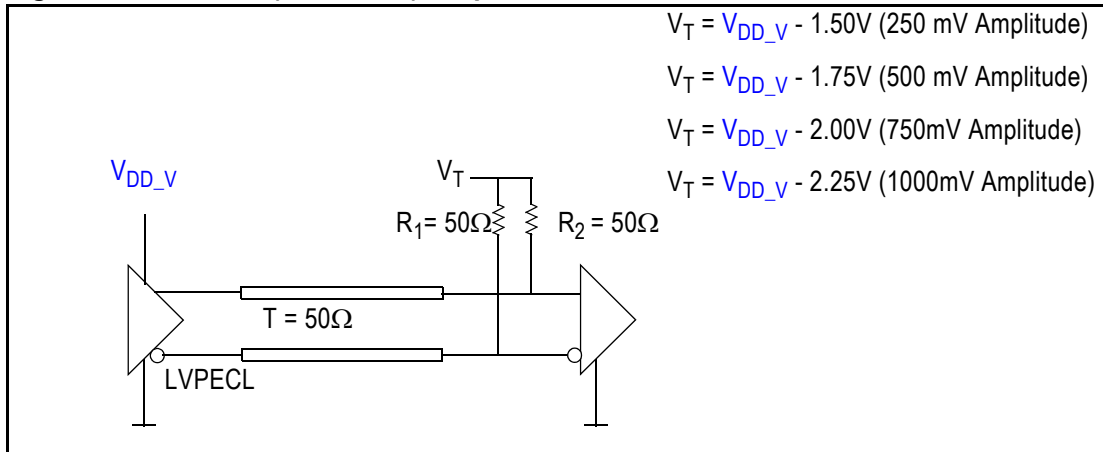

## Package Exposed Pad Thermal Release Path

In order to maximize both the removal of heat from the package and the electrical performance, a land pattern must be incorporated on the Printed Circuit Board (PCB) within the footprint of the package corresponding to the exposed metal pad or exposed heat slug on the package, as shown in Figure 16. The solderable area on the PCB, as defined by the solder mask, should be at least the same size/shape as the exposed pad/slug area on the package to maximize the thermal/electrical performance. Sufficient clearance should be designed on the PCB between the outer edges of the land pattern and the inner edges of pad pattern for the leads to avoid any shorts.

While the land pattern on the PCB provides a means of heat transfer and electrical grounding from the package to the board through a solder joint, thermal vias are necessary to effectively conduct from the surface of the PCB to the ground plane(s). The land pattern must be connected to ground through these vias. The vias act as “heat pipes”. The number of vias (i.e. “heat pipes”) are application specific and dependent upon the package power dissipation as well as electrical conductivity requirements. Thus, thermal and electrical analysis and/or testing are recommended to determine the minimum number needed. Maximum thermal and electrical performance is achieved when an array of vias is incorporated in the land pattern. It is recommended to use as many vias connected to ground as possible. It is also recommended that the via diameter should be 12 to 13mils (0.30 to 0.33mm) with 1oz copper via barrel plating. This is desirable to avoid any solder wicking inside the via during the soldering process which may result in voids in solder between the exposed pad/slug and the thermal land. Precautions should be taken to eliminate any solder voids between the exposed heat slug and the land pattern. Note: These recommendations are to be used as a guideline only. For further information, refer to the Application Note on the Surface Mount Assembly of Amkor’s Thermally/Electrically Enhance Lead-frame Base Package, Amkor Technology.

Figure 16. Assembly for Exposed Pad Thermal Release Path - Side View (drawing not to scale)

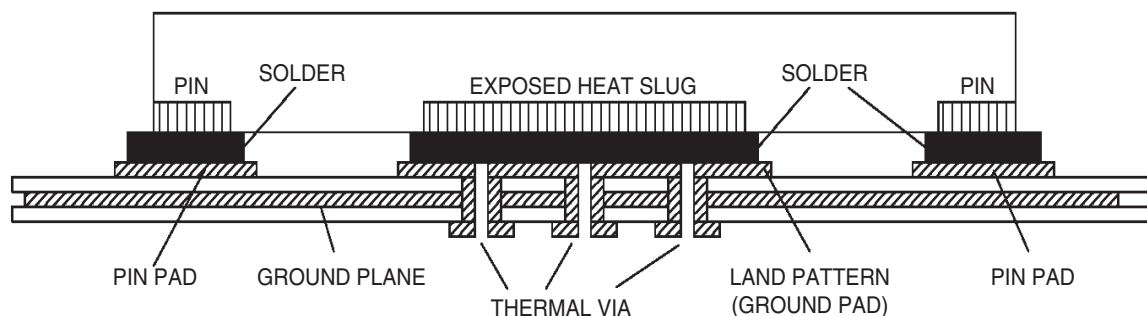

## Thermal Characteristics

Table 33. Thermal Resistance for 64-VFQFPN Package<sup>[a]</sup>

Symbol	Thermal Parameter	Condition	Value	Unit
$\Theta_{JA}$	Junction to ambient	0 m/s air flow	22.76	°C/W
		1 m/s air flow	19.25	°C/W
		2 m/s air flow	17.70	°C/W
		3 m/s air flow	16.87	°C/W
		4 m/s air flow	16.37	°C/W
		5 m/s air flow	16.03	°C/W
$\Theta_{JC}$	Junction to case		14.33	°C/W
$\Theta_{JB}$	Junction to board		1.1	°C/W

[a] Standard JEDEC 2S2P multilayer PCB.

### Case Temperature Considerations

This device supports applications in a natural convection environment which does not have any thermal conductivity through ambient air. The printed circuit board (PCB) is typically in a sealed enclosure without any natural or forced air flow and is kept at or below a specific temperature. The device package design incorporates an exposed pad (ePad) with enhanced thermal parameters which is soldered to the PCB where most of the heat escapes from the bottom exposed pad. For this type of application, it is recommended to use the junction-to-board thermal characterization parameter  $\Psi_{JB}$  (Psi-JB) to calculate the junction temperature ( $T_J$ ) and ensure it does not exceed the maximum allowed operating junction temperature in the Absolute Maximum Rating table.

The junction-to-board thermal characterization parameter,  $\Psi_{JB}$ , is calculated using the following equation:

$T_J = T_{CB} + \Psi_{JB} \times P_D$ , where:

$T_J$  = Junction temperature at steady state condition in (°C)

$T_{CB}$  = Case temperature (Bottom) at steady state condition in (°C)

$\Psi_{JB}$  = Thermal characterization parameter to report the difference between junction temperature and the temperature of the board measured at the top surface of the board

$P_D$  = power dissipation (W) in desired operating configuration

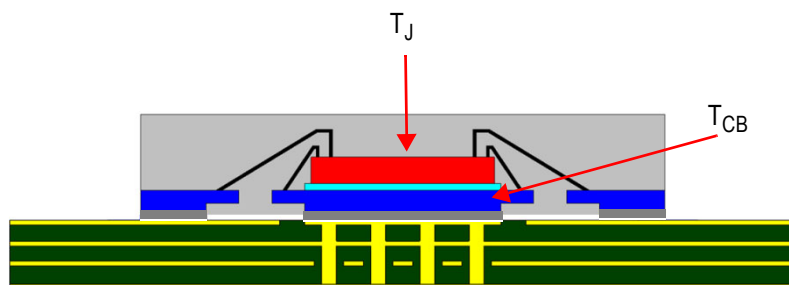

The ePad provides a low thermal resistance path for heat transfer to the PCB and represents the key pathway to transfer heat away from the IC to the PCB. It's critical that the connection of the exposed pad to the PCB is properly constructed to maintain the desired IC case temperature ( $T_{CB}$ ). A good connection ensures that temperature at the exposed pad ( $T_{CB}$ ) and the board temperature ( $T_B$ ) are relatively the same. An improper connection can lead to increased junction temperature, increased power consumption and decreased electrical performance. In addition, there could be long-term reliability issues and increased failure rate.

Example Calculation for Junction Temperature ( $T_J$ ):  $T_J = T_{CB} + \Psi_{JB} \times P_D$

Table 34. Thermal Resistance for 64-VFQFPN Package<sup>[a]</sup>

Package type	64-VFQFPN
Body size (mm)	9 x 9 x 0.85 mm
ePad size (mm)	6.00mm x 6.00mm
Thermal Via	8x8 Matrix
$\Psi_{JB}$	1.1 C/W
$T_{CB}$	85°C
$P_D$	1.766 W <sup>[b]</sup>

[a] Standard JEDEC 2S2P multilayer PCB.

[b] See Table 24, test case 6.

For the variables above, the junction temperature is  $T_J = T_{CB} + \Psi_{JB} \times P_D = 85^\circ\text{C} + 1.1^\circ\text{C/W} \times 1.766\text{W} = 86.9^\circ\text{C}$ . Since this operating junction temperature is below the maximum operating junction temperature of  $125^\circ\text{C}$ , there are no long term reliability concerns. In addition, since the junction temperature at which the device was characterized using forced convection is  $87.6^\circ\text{C}$ , this device can function without the degradation of the specified AC or DC parameters.

## Package Outline Drawings

The package outline drawings are appended at the end of this document and are accessible from the link below. The package information is the most current data available.

[www.idt.com/document/psc/64-vfqfpn-package-outline-drawing-90-x-90-x-09-mm-body-05mm-pitch-epad-60-x-60-mm-nlg64p5](http://www.idt.com/document/psc/64-vfqfpn-package-outline-drawing-90-x-90-x-09-mm-body-05mm-pitch-epad-60-x-60-mm-nlg64p5)

## Ordering Information

Orderable Part Number	Package	MSL Rating	Shipping Packaging	Temperature
8V79S680NLGI	RoHS 6/6 64-VFQFPN	3	Tray	-40°C to +85°C
8V79S680NLGI8		3	Tape and Reel	

## Marking Diagram

IDT 8V79S680NLGI #YYWW\$  ● LOT C00
---

## Glossary

Abbreviation	Description
Index $x$	Denominates a channel, channel frequency divider and the associated configuration bits. Range: A, B, C, D.
Index $y$	Denominates a QCLK output and associated configuration bits. Range: A0, A1, A2, B0, B1, C0, C1, D.
Index $r$	Denominates a QREF output and associated configuration bits. Range: A0, A1, A2, B0, B1, C0, C1, D.
$V_{DD\_V}$	Denominates voltage supply pins. Range: $V_{DD\_QCLKA}$ , $V_{DD\_QREFA01}$ , $V_{DD\_QREFA2}$ , $V_{DD\_QCLKB}$ , $V_{DD\_QREFB}$ , $V_{DD\_QCLKC}$ , $V_{DD\_QREFC}$ , $V_{DD\_QCLKD}$ , $V_{DD\_QREFD}$ , $V_{DD\_CLK}$ , $V_{DD\_REF}$ .
[...]	Index brackets describe a group associated with a logical function or a bank of outputs.
{...}	List of discrete values.

## Revision History

Date	Description of Change
January 11, 2019	<ul style="list-style-type: none"> <li>▪ Updated the <a href="#">Package Outline Drawings</a>; however, no mechanical changes</li> <li>▪ Completed other minor changes</li> </ul>
July 26, 2017	<ul style="list-style-type: none"> <li>▪ Updated the definition of nBIAS_r in <a href="#">Table 10</a></li> </ul>
June 22, 2017	<ul style="list-style-type: none"> <li>▪ Updated the description of BIAS_TYPE[1] in <a href="#">Table 10</a></li> <li>▪ Updated the Package Drawings</li> </ul>
August 4, 2016	Initial release.

## IMPORTANT NOTICE AND DISCLAIMER

RENESAS ELECTRONICS CORPORATION AND ITS SUBSIDIARIES (“RENESAS”) PROVIDES TECHNICAL SPECIFICATIONS AND RELIABILITY DATA (INCLUDING DATASHEETS), DESIGN RESOURCES (INCLUDING REFERENCE DESIGNS), APPLICATION OR OTHER DESIGN ADVICE, WEB TOOLS, SAFETY INFORMATION, AND OTHER RESOURCES “AS IS” AND WITH ALL FAULTS, AND DISCLAIMS ALL WARRANTIES, EXPRESS OR IMPLIED, INCLUDING, WITHOUT LIMITATION, ANY IMPLIED WARRANTIES OF MERCHANTABILITY, FITNESS FOR A PARTICULAR PURPOSE, OR NON-INFRINGEMENT OF THIRD-PARTY INTELLECTUAL PROPERTY RIGHTS.

These resources are intended for developers who are designing with Renesas products. You are solely responsible for (1) selecting the appropriate products for your application, (2) designing, validating, and testing your application, and (3) ensuring your application meets applicable standards, and any other safety, security, or other requirements. These resources are subject to change without notice. Renesas grants you permission to use these resources only to develop an application that uses Renesas products. Other reproduction or use of these resources is strictly prohibited. No license is granted to any other Renesas intellectual property or to any third-party intellectual property. Renesas disclaims responsibility for, and you will fully indemnify Renesas and its representatives against, any claims, damages, costs, losses, or liabilities arising from your use of these resources. Renesas' products are provided only subject to Renesas' Terms and Conditions of Sale or other applicable terms agreed to in writing. No use of any Renesas resources expands or otherwise alters any applicable warranties or warranty disclaimers for these products.

(Disclaimer Rev.1.01 Jan 2024)

### Corporate Headquarters

TOYOSU FORESIA, 3-2-24 Toyosu,  
Koto-ku, Tokyo 135-0061, Japan  
[www.renesas.com](http://www.renesas.com)

### Trademarks

Renesas and the Renesas logo are trademarks of Renesas Electronics Corporation. All trademarks and registered trademarks are the property of their respective owners.

### Contact Information

For further information on a product, technology, the most up-to-date version of a document, or your nearest sales office, please visit [www.renesas.com/contact-us/](http://www.renesas.com/contact-us/).