

### RX23E-A Group

#### Temperature Measurement Examples Using Resistance Temperature Detectors

##### Summary

This document describes temperature measurement examples with resistance temperature detectors (RTD), using RX23E-A.

RX23E-A contains an analog front-end (AFE) and a 24-bit  $\Delta$ - $\Sigma$  A/D converter (DSAD). Using the programmable gain instrumentation amplifier (PGA), excitation current source (IEXC), etc., high-precision A/D conversion is performed on the output of the resistance temperature detector to calculate the temperature.

Temperature was measured with RTD, using Renesas Solution Starter Kit for RX23E-A and sample program included in this document. Error of temperature measurement result with 3-wire RTD is shown in below figure.

Measuring range:	-40°C ~ 150°C
Board temperature:	-40°C、room temperature (about 25°C) , 85°C
Effective resolution:	21.3bit (121.2nVrms: 1.26m°C equivalent)
Noise free resolution:	18.7bit (738.2nV: 7.67m°C equivalent)

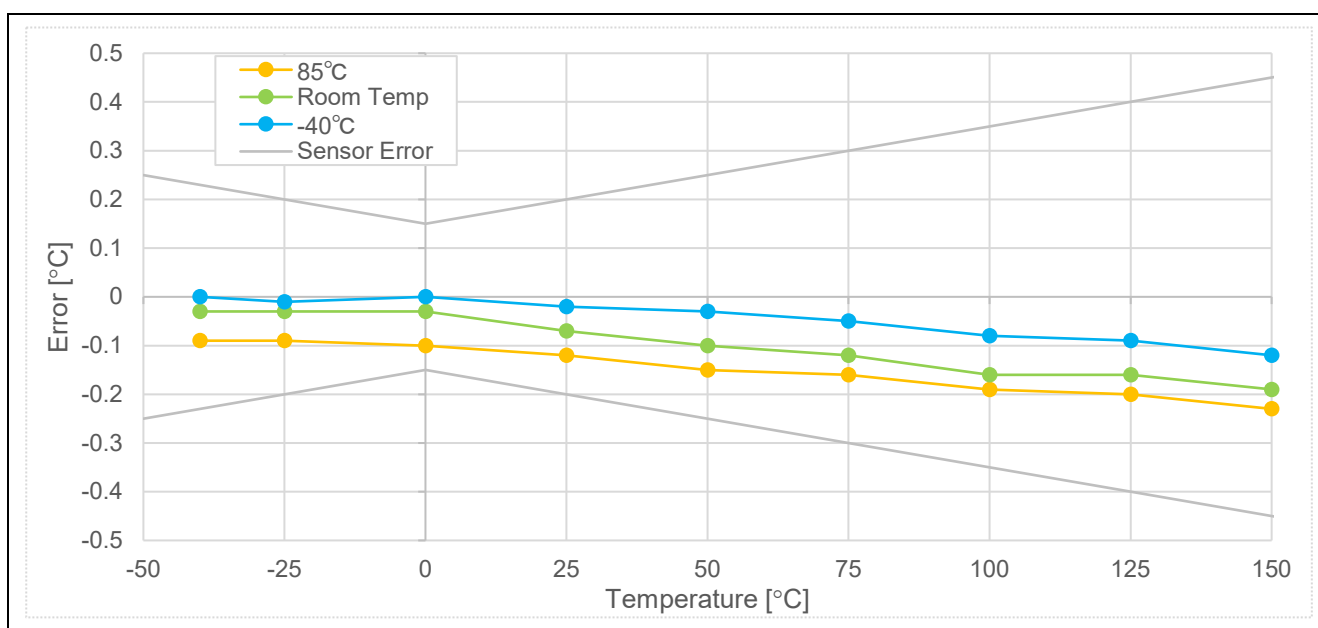

##### Target Device

RX23E-A

## Contents

1. Overview .....	3
2. Related Documents .....	3
3. Environment for Operation Confirmation .....	3
4. Temperature Measurement Systems .....	4
4.1 Resistance Temperature Detectors (RTDs) .....	5
4.2 Temperature Calculation Procedure .....	7
4.3 Other Functions .....	8
4.3.1 Calibration .....	8
4.3.2 3-Wire RTD Excitation Current Chopping .....	8
4.3.3 Linkage with the PC Tool Program .....	8
5. Sample Program .....	9
5.1 Overview of Operation .....	9
5.2 Peripheral Functions and Pins Used .....	10
5.2.1 AFE and DSAD0 .....	11
5.2.2 SCI1, DMAC0, DMAC3, and CMT0 .....	12
5.2.3 Port PH2 .....	13
5.3 Communication Control .....	14
5.4 Program Configuration .....	16
5.4.1 File Configuration .....	16
5.4.2 Macro Definitions .....	17
5.4.3 Structure .....	17
5.4.4 Functions .....	18
6. Importing a Project .....	21
6.1 Importing a Project into e <sup>2</sup> studio .....	21
6.2 Importing a Project into CS+ .....	22
7. Measurement Results with Sample Program .....	23
7.1 Memory Usage and Number of Execution Cycle .....	23
7.1.1 Build Conditions .....	23
7.1.2 Memory Usage .....	23
7.1.3 The number of Execution Cycle .....	23
7.2 Temperature Measurement .....	24
7.2.1 Measurement Condition .....	24
7.2.2 Calibration .....	24
7.2.3 Measurement Results .....	25
7.2.3.1 4-wire RTD .....	25
7.2.3.2 3-wire RTD .....	26
Revision History .....	27

## 1. Overview

This document describes temperature measurement examples using resistance temperature detectors (RTDs), with RX23E-A.

In this manual, the temperature is measured by using a 3-wire RTD or a 4-wire RTD. The sample program runs on the Renesas Solution Starter Kit for RX23E-A (RSSKRX23E-A) board. Measurement results can be displayed with the PC tool program of RSSKRX23E-A.

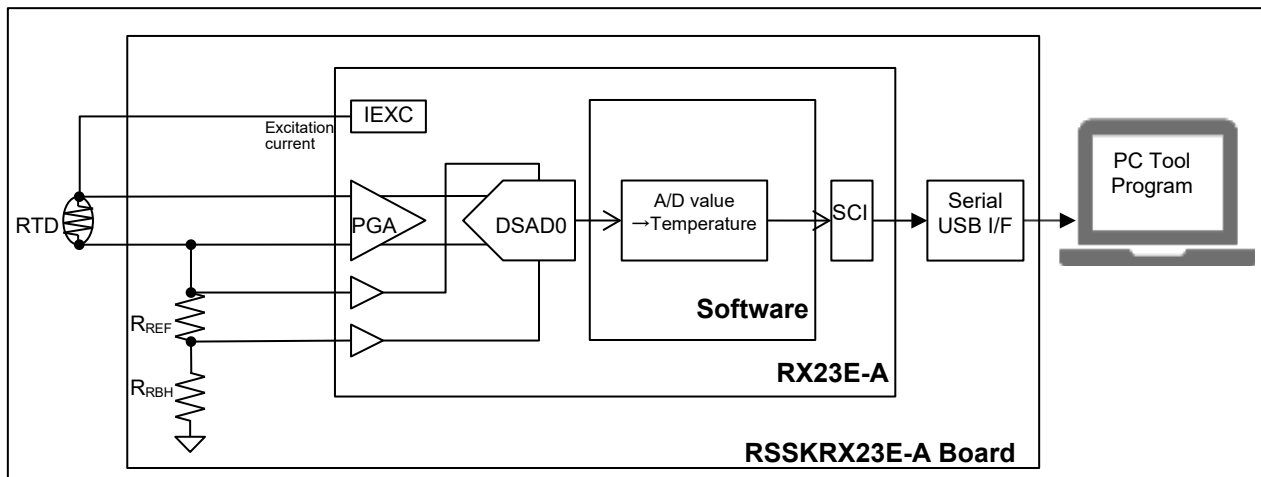

Figure 1-1 Temperature Measurement System Example Using a 4-Wire Resistance Temperature Detector

## 2. Related Documents

- R01UH0801 RX23E-A Group User's Manual: Hardware
- R20UT4542 RSSKRX23E-A User's Manual
- R20AN0540 Application Notes RSSKRX23E-A PC Tool Program Operation Manual
- R01AN4799 Application Notes RX23E-A Group Effective Use of AFE and DSAD

## 3. Environment for Operation Confirmation

The environment for operation confirmation is given in Table 3-1.

Table 3-1 Environment for Operation Confirmation

Item	Description
Board	RSSKRX23E-A board (RTK0ESXB10C00001BJ)
MCU	RX23E-A (R5F523E6ADFL) Power voltage (VCC, AVCC0): 5V Operating frequency (ICLK): 32MHz Peripheral operating frequency (PCLKB): 32MHz DSAD operating frequency (f <sub>DR</sub> ): 4MHz DSAD modulator clock frequency (f <sub>MOD</sub> ): 0.5MHz
3-wire resistance temperature detector	RS PRO 457-3710
4-wire resistance temperature detector	Correge D00539/PS3/30/20.00/PT100/CLA
IDE	Renesas e <sup>2</sup> studio V7.8.0 Renesas Smart Configurator V2.6.0
Tool Chain	Renesas CC-RX V3.2.0
Emulator	E2 Emulator Lite

### 4. Temperature Measurement Systems

Block diagrams of hardware systems using the RSSKRX23E-A board are shown in Figure 4-1 and Figure 4-2.

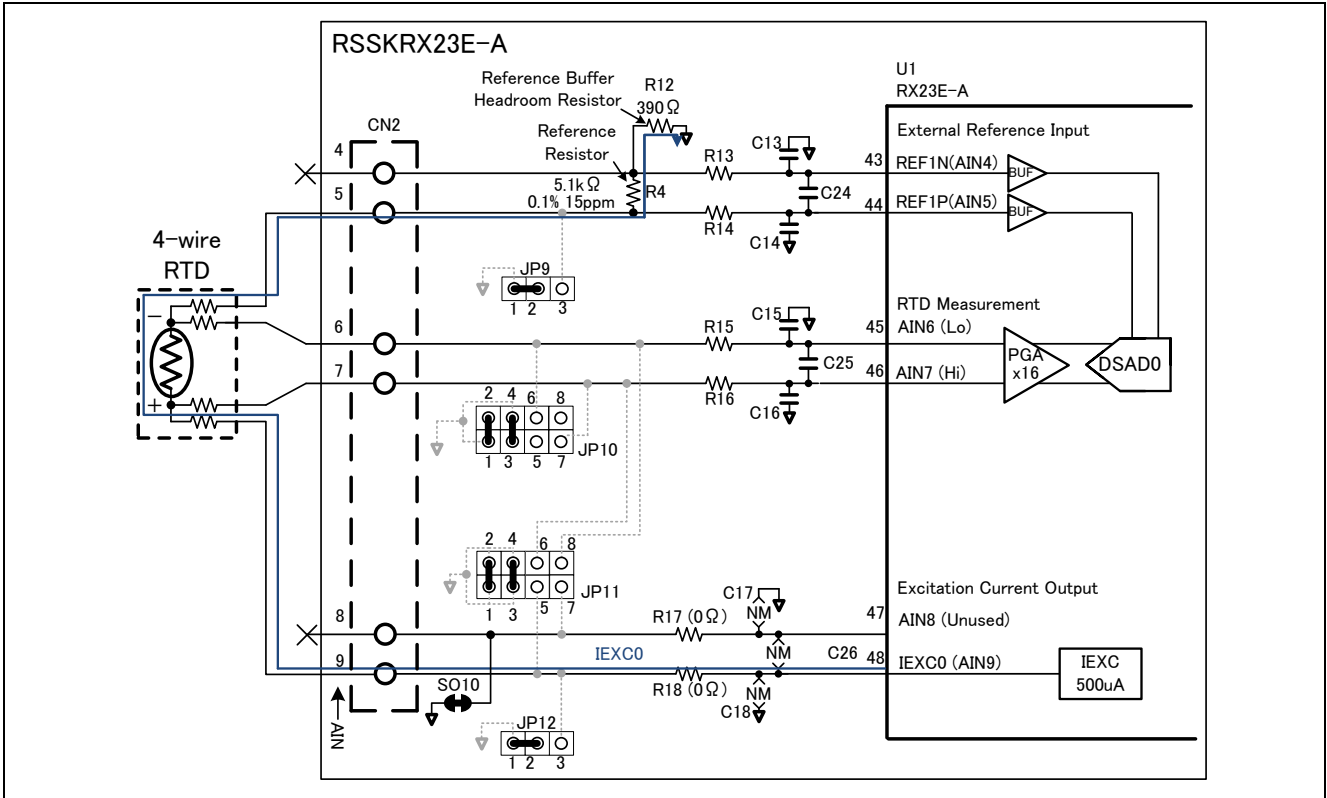

Figure 4-1 Temperature Measurement System with a 4-Wire RTD

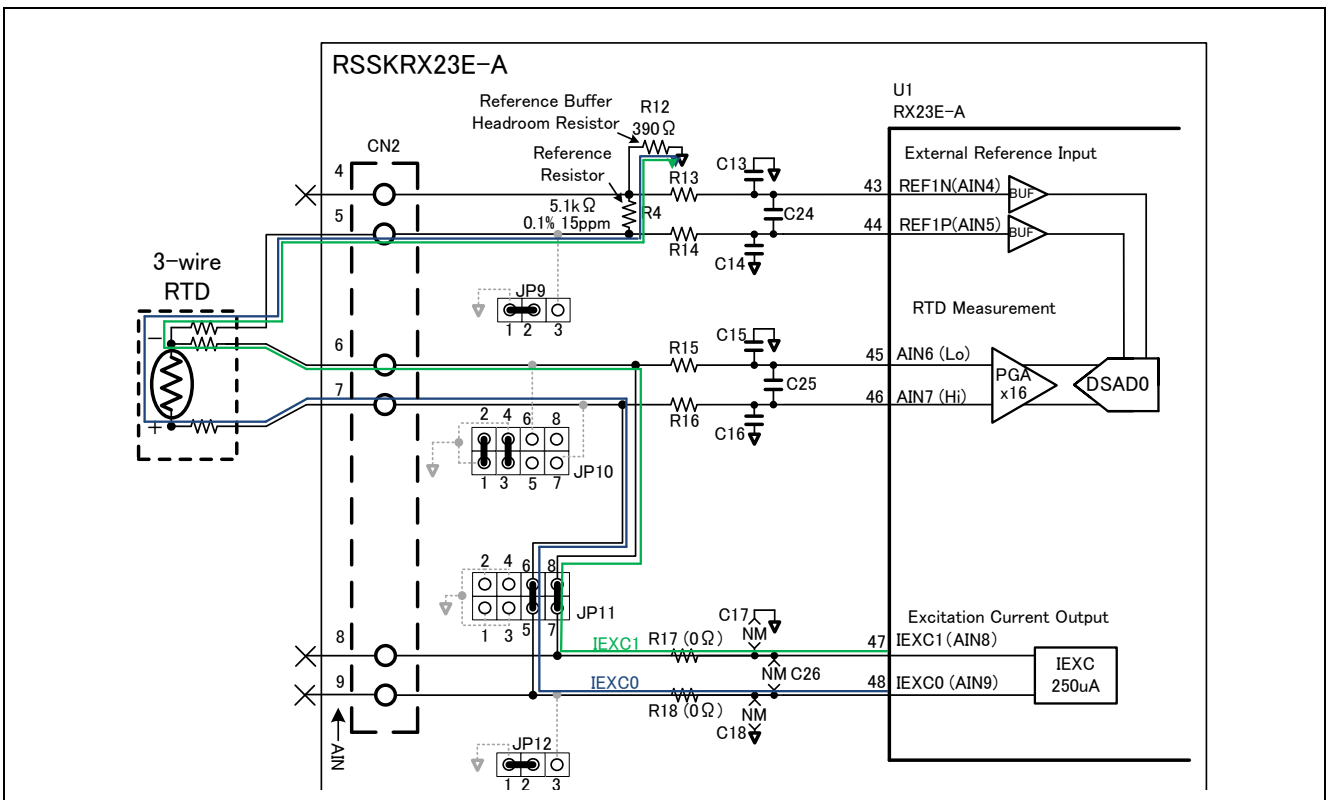

Figure 4-2 Temperature Measurement System with a 3-Wire RTD

### 4.1 Resistance Temperature Detectors (RTDs)

An RTD changes in resistance value according to the temperature. The voltage when constant current flows through the RTD is measured to determine the resistance value, which is converted to temperature.

Methods for connecting conductors inside an RTD include 2-wire, 3-wire, and 4-wire methods. In the examples, the 4-wire and 3-wire methods are used.

The 3-wire method is a frequently used connection method. If the three conductors are the same in length, material, electric resistance, etc., the impact of the temperature measurement resistance can be avoided. Although more expensive than the 3-wire method, the 4-wire method can fully avoid the impact of the conductor resistance in principle of measurement.

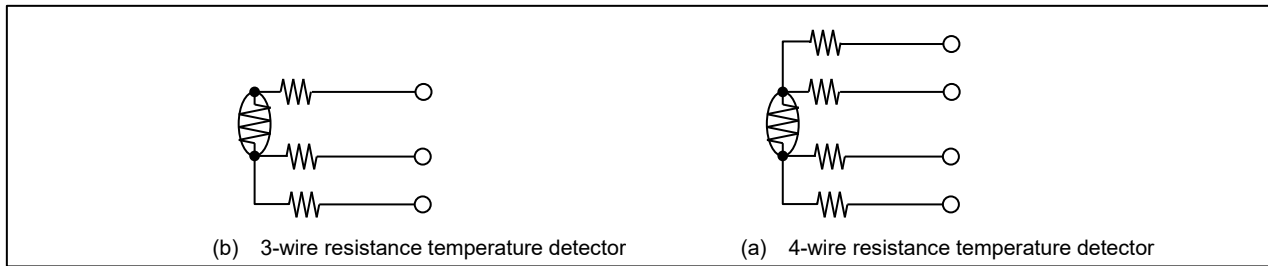

Figure 4-3 Resistance Temperature Detectors

An excerpt of the specifications of the RTDs used in the examples is given in Table 4-1, and the temperature vs. resistance value characteristics are shown in Figure 4-4.

Table 4-1 Excerpt of the Resistance Temperature Detector Specifications

Item	3-wire (457-3710)	4-wire (D00539/PS3/30/20.00/PT100/CLA)
Type	pt100	
Tolerance Class	Class A	
Resistance values R0 at 0°C	100[Ω]	
Operating temperature range	-50 to 250[°C]	
Measurement current (DC)	-	0.5 to 2.0[mA]

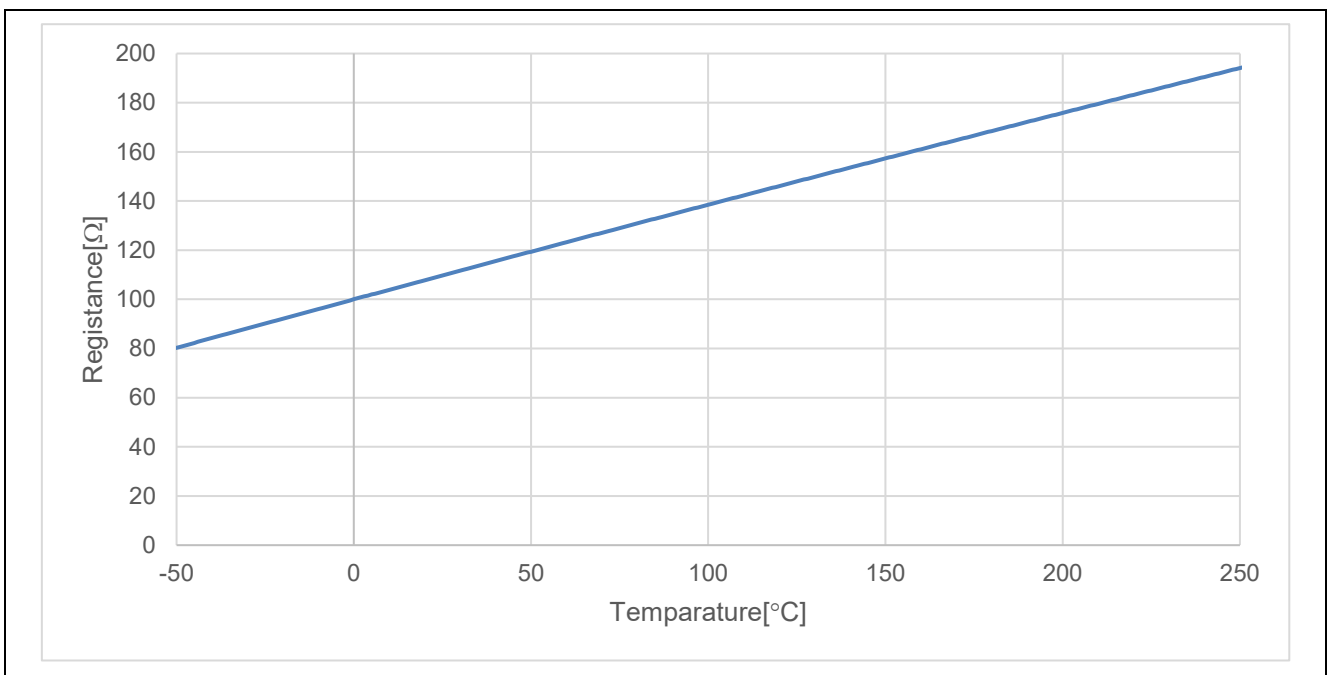

Figure 4-4 Temperature vs. Resistance Value of a Pt100Ω Platinum Resistance Temperature Detector (from IEC 60751)

Each example conducts ratiometric measurement. To the RTD and the reference resistance  $R_{REF}$ , which are connected in series, constant current is applied, and with the voltage  $V_{REF}$  applied to  $R_{REF}$  as the reference voltage, the voltage of the RTD is A/D converted.

From the A/D conversion value, the resistance value of the RTD is calculated, and the resistance value is converted to temperature. The resistance value of the RTD is non-linear in relation to temperature, so that the resistance value is converted to temperature, using a table specifying the resistance value in relation to temperature. From the Pt100Ω reference resistance value table of IEC 60751, and according to the measurement range of the RTD used, each example uses, in a range of -50°C to 251°C, a resistance value table in increments of 1°C.

The RTD measurement conditions in each example are listed in Table 4-2. If the oversampling ratio is not a power of two, the digital filter of the DSAD generates a gain of x1/2 to x1. The A/D conversion value is treated as having been multiplied by the above-mentioned gain.

Table 4-2 RTD Measurement Conditions

Item	4-wire	3-wire	Remarks
Excitation current $I_{EXC}$	500uA	250uA	The 3-wire method has two systems.
PGA gain $G_{PGA}$	x16		
Reference resistance value $R_{REF}$	5.1kΩ		
DSAD reference voltage $V_{REF}$	2.55V		The voltage applied to $R_{REF}$ is assumed to be the A/D conversion reference voltage. 3-wire: $V_{REF} = 2I_{EXC} \times R_{REF} = 2.55V$ 4-wire: $V_{REF} = I_{EXC} \times R_{REF} = 2.55V$ Because of high impedance, a reference voltage buffer is used.
Oversampling ratio OSR	50000		A/D conversion value output rate 10SPS
Digital filter gain $G_{DF}$	0.677626358		$G_{DF} = 1/2^{(Ceil(4 \log_2 OSR) - 4 \log_2 OSR)}$
DSAD output format	2's Complement		

## 4.2 Temperature Calculation Procedure

### (1) RTD resistance value calculation

From the A/D conversion value  $DATA_{RTD}$  of the RTD, the resistance value of the RTD is determined. Assuming that the set gain of the PGA is  $G_{PGA}$ , the digital filter gain is  $G_{DF}$ , the full scale of the A/D conversion value is  $2^{24}$ , and the reference resistance value is  $R_{REF}$ , the resistance value  $R_{RTD4}$  of the 4-wire RTD and resistance value  $R_{RTD3}$  of the 3-wire RTD can be calculated with the respective formulas below.

For the 4-wire RTD, the same current flows through the reference resistance and the RTD. Thus,

$$V_{RTD4} = I_{EXC}R_{RTD4} = \frac{2V_{REF}}{2^{24} \cdot G_{PGA} \cdot G_{DF}} \cdot DATA_{RTD} = \frac{2(I_{EXC}R_{REF})}{2^{24} \cdot G_{PGA} \cdot G_{DF}} \cdot DATA_{RTD} [V]$$

The above formula can be rearranged to:

$$R_{RTD4} = \frac{2 \cdot R_{REF}}{2^{24} \cdot G_{PGA} \cdot G_{DF}} \cdot DATA_{RTD} = \frac{R_{REF}}{2^{23} \cdot G_{PGA} \cdot G_{DF}} \cdot DATA_{RTD} [\Omega]$$

For the 3-wire RTD, the current that flows through the reference resistance is twice as large as the current that flows through the RTD. Thus,

$$V_{RTD3} = I_{EXC}R_{RTD3} = \frac{2V_{REF}}{2^{24} \cdot G_{PGA} \cdot G_{DF}} \cdot DATA_{RTD} = \frac{2(2I_{EXC} \cdot R_{REF})}{2^{24} \cdot G_{PGA} \cdot G_{DF}} \cdot DATA_{RTD} [V]$$

The above formula can be rearranged to:

$$R_{RTD3} = \frac{4R_{REF}}{2^{24} \cdot G_{PGA} \cdot G_{DF}} \cdot DATA_{RTD} = \frac{R_{REF}}{2^{22} \cdot G_{PGA} \cdot G_{DF}} \cdot DATA_{RTD} [\Omega]$$

### (2) Resistance value-to-temperature conversion

From the temperature vs. resistance value table for the RTD, the (temperatures, resistance values) before and after the resistance value  $R_{RTD}$  of the RTD are obtained, and from the obtained results, the temperature  $T_{RTD}$  equivalent to the resistance value  $R_{RTD}$  is determined with linear interpolation.

Assuming that the resistance value is  $R$  and the temperature is  $T$ , from the fact that the ratios of the distances from point a to measurement point c ( $T_{RTD}, R_{RTD}$ ) on the T-axis and the R-axis to the distances between two points a ( $T_1, R_1$ ) and b ( $T_2, R_2$ ) on the T-axis and the R-axis on the obtained table are the same, the relationship can be expressed with the formula below.

$$\frac{R_{RTD} - R_1}{R_2 - R_1} = \frac{T_{RTD} - T_1}{T_2 - T_1} = \alpha$$

The above formula is rearranged so that the temperature  $T_{RTD}$  for the resistance value  $R_{RTD}$  can be calculated with the formula below.

$$T_{RTD} = T_1 + \alpha(T_2 - T_1) = T_1 + \frac{R_{RTD} - R_1}{R_2 - R_1} \cdot (T_2 - T_1)$$

### 4.3 Other Functions

#### 4.3.1 Calibration

With temperature measurement using an RTD, high-precision temperature measurement can be conducted by increasing the RTD resistance value calculation precision. For this reason, calibration is conducted by using a resistor whose value is known, instead of the RTD, so that the voltage applied to the ends of the resistor when constant current is applied becomes the expected A/D conversion value.

In calibration, a resistor whose value is known, a "resistance temperature detector calibrator", or something similar is connected, instead of the RTD in Figure 4-1 or Figure 4-2, the gain error and the offset error of the A/D conversion value are calculated for correction.

The DSAD of RX23E-A can correct the gain and the offset for the A/D conversion value. For details, refer to "34.3.9 Offset Error/Gain Error Correction Function" in "RX23E-A Group User's Manual: Hardware".

The expected A/D conversion value  $DATA_{RTD}$  can be determined with the formulas below from the formulas in 4.2(1).

4-wire RTD:

$$DATA_{RTD4} = \frac{2^{23} \cdot G_{PGA} \cdot G_{DF}}{R_{REF}} \cdot R_{RTD4}$$

3-wire RTD:

$$DATA_{RTD3} = \frac{2^{22} \cdot G_{PGA} \cdot G_{DF}}{R_{REF}} \cdot R_{RTD3}$$

#### 4.3.2 3-Wire RTD Excitation Current Chopping

This is a method for averaging A/D conversion results by switching between  $I_{exc0}$  and  $I_{exc1}$  to cancel variations in excitation current.

For details, refer to the application notes, "RX23E-A Group Effective Use of AFE and DSAD".

#### 4.3.3 Linkage with the PC Tool Program

The sample program can communicate with the PC tool program of RSSKRX23E-A to display temperature measurement results with the PC tool program.

For details about the communication specifications, refer to "RSSKRX23E-A PC Tool Program Operation Manual".

The communication commands supported in the examples are listed in Table 4-3.

Table 4-3 Supported Functions

Command	Overview	Remarks
Negotiation	Reads MCU endian information and MCU functions	
Read	Reads registers	
Run	Starts DSAD conversion operation	
Stop	Stops DSAD conversion operation	
TransmissionCh0	Transmits Ch0 data from the MCU	Transmits a temperature [°C] as a physical quantity



## 5. Sample Program

This sample program can be selected the use of 3-wire or 4-wire RTD by macro definition in `r_rtd_api.h`. Refer to the “5.4.2 Macro Definitions” for how to change.

### 5.1 Overview of Operation

Figure 5-1 shows the process flow of this sample program.

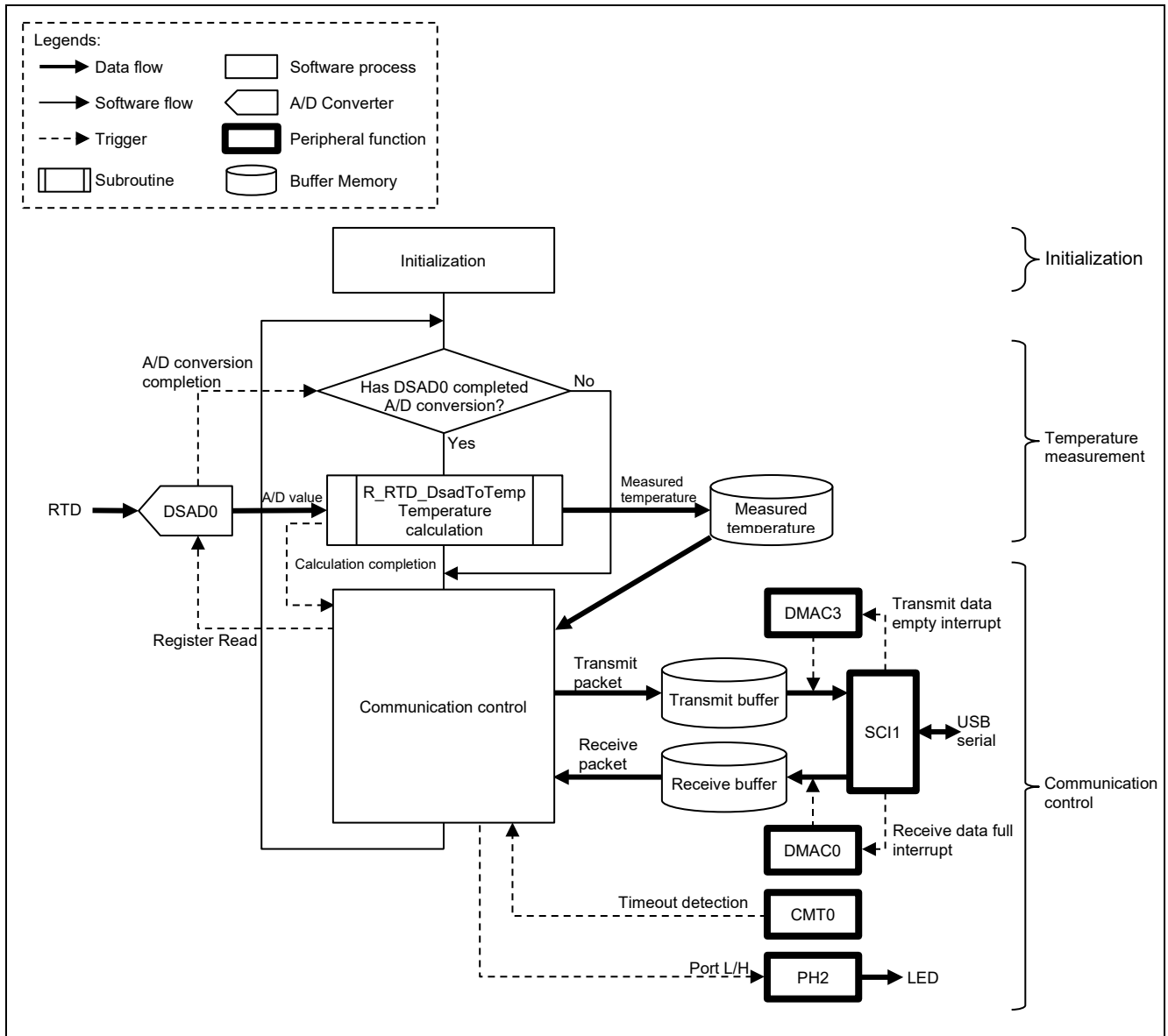

Figure 5-1 Temperature Measurement Process Flow

The following provides an overview of each process.

- Initialization

The following are performed.

- If a connection is made to the PC tool program of RSSKRX23E-A, the initialization of the communication buffer and the start of SCI1 operation
- Start of the A/D conversion of DSAD0

- Temperature measurement

With the completion of the A/D conversion of DSAD0 as a trigger, the temperature of the RTD is calculated from the A/D conversion value. For details about the temperature calculation procedure, see 4.2.

- Communication control

If a connection is made to the PC tool program of RSSKRX23E-A, a communication process is performed to transmit measured temperature.

While measured temperature is being transmitted, LED1 is ON. For details, see 5.3.

## 5.2 Peripheral Functions and Pins Used

The peripheral functions used in the examples are listed in Table 5-1, and the pins used are listed in Table 5-2. The conditions for setting each peripheral function are described together.

The settings for peripheral functions are generated by using the code generation function of Smart Configurator (referred to as SC in the remainder of this manual).

Table 5-1 Peripheral Functions Used

Peripheral function	Use
AFE, DSAD0	Driving of an RTD, A/D conversion
SCI1	UART communication with the PC tool program
DMAC0	Data transfer with a receive data full interrupt of SCI1 as a trigger
DMAC3	Data transfer with a transmit data empty interrupt of SCI1 as a trigger
CMT0	Detection of a communication timeout of SCI1
Port PH2	LED1 ON/OFF control

Table 5-2 Pins Used

Pin name	Input/Output	Use	
		3-wire RTD	4-wire RTD
PH2	Output	LED1 ON/OFF control	
P26/TXD1	Output	UART1 transmit pin	
P30/RXD1	Input	UART1 receive pin	
P31/CTS1#	Input	CTS signal input pin	
AIN8/IEXC1	Output	RTD excitation current output pin	Not used
AIN9/IEXC0	Output	RTD excitation current output pin	
AIN7	Input	RTD + side input pin	
AIN6	Input	RTD -side input pin	
AIN5/REF1P	Input	RTD measurement DSAD + side reference voltage	
AIN4/REF1N	Input	RTD measurement DSAD - side reference voltage	

5.2.1 AFE and DSAD0

The conditions for setting AFE and DSAD0 based on the measurement conditions in Table 4-2 are listed in Table 5-3 and Table 5-4.

Table 5-3 AFE and DSAD0 Settings

Item		Setting
Analog input channel setting		<ul style="list-style-type: none"> <li>Channel 0: Valid</li> <li>Channels 1 to 5: Invalid</li> </ul>
$\Delta\Sigma$ A/D operating voltage select		3.6V-5.5V (high precision)
$\Delta\Sigma$ A/D converter operating mode setting		Normal mode
Operating clock setting		PCLKB/8 4 MHz
Start trigger source		Software trigger
Interrupt setting		Not used
Inter-unit synchronous start setting		Disable synchronous start
Abnormal voltage and disconnection detection Setting		Not used
Channel 0	Analog input setting	<ul style="list-style-type: none"> <li>Positive input signal: AIN7</li> <li>Negative input signal: AIN6</li> <li>Reference voltage: REF1P/REF1N</li> <li>Enable + side reference voltage buffer</li> <li>Enable - side reference voltage buffer</li> </ul>
	Amplifier setting	<ul style="list-style-type: none"> <li>Amplifier selection: PGA</li> <li>PGA gain setting: x16</li> </ul>
	$\Delta\Sigma$ A/D conversion setting	<ul style="list-style-type: none"> <li>A/D conversion mode: Normal operation</li> <li>Data format: Two's complement format</li> <li>Number of A/D conversions: 1 in immediate value mode</li> <li>Oversampling ratio: 50000</li> <li>Offset correction: Not set (use of the device default)</li> <li>Gain correction: Not set (use of the device default)</li> <li>Use averaged data: Disabled</li> </ul>
	Disconnection assist setting	Not permitted

Table 5-4 AFE Settings

Item	4-wire RTD setting	3-wire RTD setting
Bias voltage output setting	Not set	
Excitation current setting	<ul style="list-style-type: none"> <li>Excitation current output enable</li> <li>Operating mode: 2 channel output mode</li> <li>Excitation current: 500<math>\mu</math>A</li> <li>IEXC0 output pin: AIN9 pin</li> <li>IEXC0 disconnect detection assist : Disabled</li> <li>IEXC1 output pin: Output disabled</li> <li>IEXC1 disconnect detection assist : Disabled</li> </ul>	<ul style="list-style-type: none"> <li>Excitation current output enable</li> <li>Operating mode: 2 channel output mode</li> <li>Excitation current: 250<math>\mu</math>A</li> <li>IEXC0 output pin: AIN9 pin</li> <li>IEXC0 disconnect detection assist : Disabled</li> <li>IEXC1 output pin: AIN8 pin</li> <li>IEXC1 disconnect detection assist : Disabled</li> </ul>
low voltage detector setting	Not set	
Low-Side Switch Control setting	Not set	

5.2.2 SCI1, DMAC0, DMAC3, and CMT0

For communication with the PC tool program, SCI1 is used in asynchronous mode. To obtain receive data, DMAC0 is used, and to set transmit data, DMAC3 is used. To detect a communication timeout, CMT0 is used.

The conditions for setting each peripheral function are listed below.

Table 5-5 SCI1 Settings

Item	Setting
Serial communication method	Asynchronous communication
Start bit detection	Low level at RXD1 pin
Data bit length	8 bits
Parity setting	Prohibited
Stop bit setting	1 bit
Data transfer direction setting	LSB first
Transfer speed setting	<ul style="list-style-type: none"> <li>• Transfer clock: Internal clock</li> <li>• Bit rate: 3 Mbps</li> <li>• Enable bit rate modulation function</li> <li>• SCK1 pin function: Not use SCK1</li> </ul>
Noise filter setting	Not use noise filter
Hardware flow control setting	CTS1#
Data processing setting	Transmit data processing: Process with DMAC3 Receive data processing: Process with DMAC0
Interrupt setting	Not permit receive error interrupt
Callback function setting	None
Input/output pins	<ul style="list-style-type: none"> <li>• Output: TXD1 (P26)</li> <li>• Input: RXD1 (P30)           : CTS1 (P31)</li> </ul>

Table 5-6 DMAC Settings

Item	Setting	
Channel used	DMAC0	DMAC3
DMA activation source	SCI1 (RXI1)	SCI1 (TXI1)
Activation source flag control	Clear activation source flag	Clear activation source flag
Transfer mode	Free running mode	Normal transfer
Transfer data size	8bit	8bit
Number of transfers/repeat size/block size	-	Set with software
Source address	<ul style="list-style-type: none"> <li>0008 A025h (SCI1.RDR)</li> <li>Address fixing</li> </ul>	<ul style="list-style-type: none"> <li>Set with software</li> <li>Address increment</li> <li>Set an extended repeat area at the destination address</li> <li>Extended repeat area: Lower 12 bits of the address (4KB)</li> </ul>
Destination address	<ul style="list-style-type: none"> <li>Set with software</li> <li>Address increment</li> <li>Set an extended repeat area at the destination address</li> <li>Extended repeat area: Lower 9 bits of the address (512 bytes)</li> </ul>	<ul style="list-style-type: none"> <li>0008 A023h (SCI1.TDR)</li> <li>Address fixing</li> </ul>
Interrupt setting	Not permit interrupt	Not permit interrupt

Table 5-7 CMT0 Settings

Item	Setting
Clock setting	PCLKB/512
Compare match setting	Interval time: 1000 ms Compare match interrupt (CMI0) enabled Level 0 (interrupt disabled)

### 5.2.3 Port PH2

By using port PH2, LED1 is turned ON and OFF. While measurement results are being transmitted to the PC tool program, LED1 is ON.

The condition for setting port PH2 is listed in Table 5-8.

Table 5-8 Port PH2 Setting

Item	Setting
PORTH	PH2: Output CMOS output Output 1

### 5.3 Communication Control

Based on the communication specifications of RSSKRX23R-A, processes with the PC tool program are performed.

A flow of communication processes is shown in Figure 5-2.

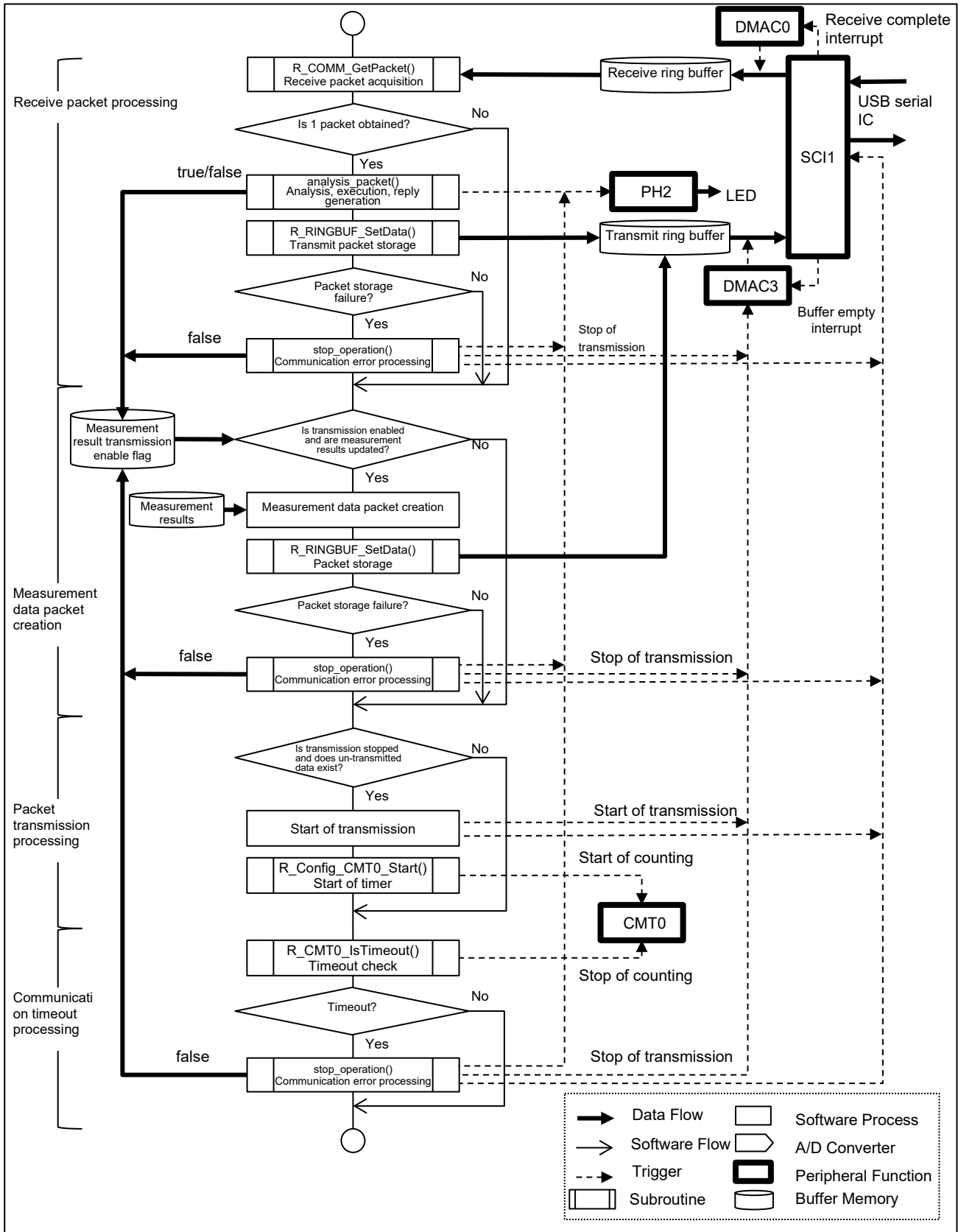

Figure 5-2 Communication Process Flow

The following provides an overview of each process.

- Receive packet processing

Obtains a received packet from the receive ring buffer, and performs processing corresponding to a command in the packet, then creates and stores a reply packet in the transmit ring buffer. Table 5-9 lists the commands supported by this program and the processes corresponding to the commands. For an unsupported command, a NACK is returned.

If the reply packet cannot be stored in the transmit ring buffer, communication error processing is performed.

Table 5-9 Packets and Actions

Command	Process
Negotiation	Return the software status with a reply packet
Read	Return the read value of the specified register with a reply packet
Run	Set the measurement result transmission enable flag and turn LED1 ON
Stop	Clear the measurement result transmission enable flag and turn LED1 OFF

- Measurement data packet creation

If the measurement result transmission enable flag is set and the measurement results are updated, a TransmissionCh0 reply packet is created from the measurement results and is stored in the transmit ring buffer.

If the reply packet cannot be stored in the transmit ring buffer, communication error processing is performed.

- Packet transmission processing

If data is not being transmitted and the transmit ring buffer contains un-transmitted data, transmission starts with DMAC3 and 1-second counting starts with CMT0 for timeout detection.

- Communication timeout processing

If transmission is completed, CMT0 for timeout detection is stopped.

If transmission is in progress, the timer is checked for a compare match, and if a compare match has occurred, this is judged as a timeout. If it is judged as a timeout, communication error processing is performed.

- Communication error processing

If the transmit packet cannot be stored in the transmit ring buffer or a communication timeout occurs, communication is stopped and the following processes are performed to make a reconnection possible.

- Stop SCI1 and DMAC3, which are used for transmission
- Clear the transmit buffer and the temperature data transmission enable flag
- Turn LED1 OFF

Each ring buffer used for transmission and reception is for DMAC transmission, therefore, their address is arranged in the alignment adjusted for each buffer size. In this program, section name is declared "B\_DMACEPEAT\_AREA\_1" and arrangement is set based on the largest buffer size.

## 5.4 Program Configuration

### 5.4.1 File Configuration

Table 5-10 File Configuration

Folder name, file name	Description
src	
└ smc_gen	Smart Configurator generation
├ general	
├ r_bsp	
├ Config_AFE	
├ Config_CMT0	
├ Config_DMACH0	
├ Config_DMACH3	
├ Config_DSAD0	
├ Config_PORT	
├ Config_SCI1	
├ r_config	
└ r_pincfg	
└ r_ring_buffer_control_api.c	
└ r_ring_buffer_control_api.h	Ring buffer control API definition
└ r_sensor_common_api.c	Table search, linear interpolation process program
└ r_sensor_common_api.h	Table search, linear interpolation process API definition
└ r_rtd_api.c	Resistance temperature detector measurement calculation program, temperature vs. resistance value table
└ r_rtd_api.h	Resistance temperature detector measurement calculation API definition
└ r_communication_control_api.c	Communication control program
└ r_communication_control_api.h	Communication control API definition
└ main.c	Main processing



## 5.4.2 Macro Definitions

Table 5-11 main.c Definition

Definition name	Type	Value	Description
D_PRV_PC_TOOL_USE	bool	1	Communication with the PC tool program is 0: Not used 1: Used

Table 5-12 r\_rtd\_api.h Definitions

Definition name	Type	Value	Description
D_RTD_SELECT	uint8_t	0	RTD selection 0: 4-wire 1: 3-wire
D_RTD_PGA_GAIN	float	16.0F	Gain of PGA for RTD measurement $G_{PGA}$ [x]
D_RTD_CODE_FS	uint32_t	16777216	$2^{24}$
D_RTD_RREF	float	5100.0F	$R_{REF}$ resistance value [ $\Omega$ ]
D_RTD_DF_GAIN	float	0.677626F	Digital filter gain $G_{DF}$
D_RTD_GAIN	float	<4-wire> $D\_RREF * 2 /$ $(D\_CODE\_FS *$ $D\_DSAD0\_GAIN *$ $D\_DF\_GAIN)$ <3-wire> $D\_RREF * 4 /$ $(D\_CODE\_FS *$ $D\_DSAD0\_GAIN *$ $D\_DF\_GAIN)$	Coefficient for conversion from A/D value to RTD resistance value [ $\Omega$ ] <4-wire> $\frac{2R_{REF}}{2^{24} \cdot G_{PGA} \cdot G_{DF}}$ <3-wire> $\frac{4R_{REF}}{2^{24} \cdot G_{PGA} \cdot G_{DF}}$
D_RTD_OFFSET	float	0.0F	RTD resistance value offset [ $\Omega$ ]
D_RTD_TABLE_SIZE	uint16_t	302	Number of table elements
D_RTD_TABLE_TOP_TEMPERATURE	float	-50.0F	Top temperature in the table [ $^{\circ}\text{C}$ ]

## 5.4.3 Structure

Table 5-13 r\_ring\_buffer\_control\_api.h Structure

Structure type name	st_ring_buf_t		
Member variable	Type	Name	Description
	uint8_t *	p_buf	Pointer to the ring buffer
	size_t	length	Ring buffer length
	uint32_t	r_index	Read index
	uint32_t	w_index	Write index

5.4.4 Functions

Table 5-14 main.c Functions

Function name/Overview	Return value		Argument			
	Type	Value	I/O	Type	Variable name	Description
main main function	void	-	-	void	-	-
stop_operation Stop DMAC/SCI, initializes the ring buffer and turns LED1 OFF	void	-	I	st_ring_buf_t *	ary	Pointer to the ring buffer
analysis_pakect According to the receive packet, executes the command and stores a reply packet. For the Run/Stop commands, updates the measurement result transmission enable flag.	size_t	Reply data length	I	uint8_t const	recv_pck[]	Receive packet storage array
			O	uint8_t	send_pck[]	Reply packet storage array
				bool *	p_tx_flag	Pointer to the measurement result transmission enable flag

Table 5-15 r\_communication\_control\_api Function

Function name/Overview	Return value		Argument			
	Type	Value	I/O	Type	Variable name	Description
R_COMM_GetPaket Reads a single packet from the receive ring buffer.	size_t	Packet length [Bytes]	I	st_ring_buf_t *	r_buf	Pointer to the receive ring buffer
			O	uint8_t	r_packet[]	Receive packet storage array

Table 5-16 r\_ring\_buffer\_control\_api Functions

Function name/Overview	Return value		Argument			
	Type	Value	I/O	Type	Variable name	Description
R_RINGBUF_GetData Reads a specified number of bytes from the ring buffer	size_t	Number of bytes to read	I	st_ring_buf_t *	ary	Pointer to the ring buffer
			O	uint8_t	data[]	Data storage array
			I	size_t	len	Number of bytes to read
			I	bool	index_update	Index update flag true: Update false: Not update
R_RINGBUF_SetData Writes a specified number of bytes to the ring buffer	size_t	Number of bytes to write	O	st_ring_buf_t *	ary	Pointer to the ring buffer
			I	uint8_t	data[]	Data storage array
			I	size_t	len	Number of bytes to write
R_RINGBUF_GetDataLength Reads a specified number of bytes stored in the ring buffer	size_t	Number of bytes stored	I	st_ring_buf_t *	ary	Pointer to the ring buffer
R_RINGBUF_SetDataIndex Updates the index of the ring buffer	uint32_t	Index value	O	st_ring_buf_t *	ary	Pointer to the ring buffer
			I	uint16_t	value	Index value
			I	uint8_t	select	Target index 0: Read, 1: Write

Table 5-17 r\_sensor\_common\_api Functions

Function name/Overview	Return value		Argument			
	Type	Value	I/O	Type	Variable name	Description
R_CALC_BinarySearch Does a binary search for the data to search for from the search table, and returns the index of a recent value that does not exceed the data to search for	uint16_t	Index value	I	const float *	p_data_table	Pointer to the search table (ascending order)
			I	uint16_t	table_size	Number of elements in the search table
			I	float	data	Data to search for
R_CALC_Lerp From two points (x0,y0) and (x1,y1), determine y for input x with linear interpolation	float	Linear interpolation results	I	float	x0	x0 value
			I	float	y0	y0 value
			I	float	x1	x1 value
			I	float	y1	y1 value
			I	float	x	x value

Table 5-18 r\_rtd\_api Function

Function name/Overview	Return value		Argument			
	Type	Value	I/O	Type	Variable name	Description
R_DsadToTemp Calculates the temperature from the A/D conversion value	float	Temperature [°C]	I	float	dsad	A/D conversion value

Table 5-19 Config\_CMT0 User Defined Functions

Function name/Overview	Return value		Argument			
	Type	Value	I/O	Type	Variable name	Description
R_CMT0_IsTimeout Returns information as to whether a timeout has occurred	bool	false: Counting true: Timeout	I	bool	flag	Stop of counting false: Continuation true: Stop
R_CMT0_CntClear Clears the compare match timer/counter of CMT0	void *	DMAC0.DMDAR	-	void	-	

Table 5-20 Config\_DMACH0 User Defined Functions

Function name/Overview	Return value		Argument			
	Type	Value	I/O	Type	Variable name	Description
R_DMACH0_SetDestAddr Sets the DMDAR of DMACH0	void	-	I	void *	p_addr	destination address
R_DMACH0_GetDestAddr Returns the DMDAR of DMACH0 (macro function)	void	-	-	void	-	-

Table 5-21 Config\_DMCA3 User Defined Functions

Function name/Overview	Return value		Argument			
	Type	Value	I/O	Type	Variable name	Description
R_DMCA3_SetSrcAddr Sets the DMSAR of DMCA3	void	-	I	void *	p_addr	source address
R_DMCA3_SetTxCnt Sets the DMCRA of DMCA3	void	-	I	uint32_t	cnt	transfer count

Table 5-22 Config\_DSAD0 User Defined Functions

Function name/Overview	Return value		Argument			
	Type	Value	I/O	Type	Variable name	Description
R_DSAD0_IsConversionEnd Return the AD conversion status of DSAD0	bool	false: Conversion true: Conversion end	-	void	-	-
R_DSAD0_ClearIrFlag Clears the IR flag of DSAD0	void	-	-	void	-	-

Table 5-23 Config\_PORT User Defined Functions

Function name/Overview	Return value		Argument			
	Type	Value	I/O	Type	Variable name	Description
R_LED1_On Turns LED1 ON (macro function)	void	-	-	void	-	
R_LED1_Off Turns LED1 OFF (macro function)	void	-	-	void	-	

Table 5-24 Config\_SCI1 User Defined Functions

Function name/Overview	Return value		Argument			
	Type	Value	I/O	Type	Variable name	Description
R_SCI1_IsTransferEnd returns the transfer status of SCI1	bool	false: Transferring true: Transfer end	-	void	-	
R_SCI1_SendStart start transmission of SCI1	MD_STATUS	MD_OK	-	void	-	
R_SCI1_SendStop stop transmission of SCI1	MD_STATUS	MD_OK	-	void	-	
R_SCI1_ReceiveStart starts receiving of SCI1.	MD_STATUS	MD_OK	-	void	-	

## 6. Importing a Project

After importing the sample project, make sure to confirm build and debugger setting.

### 6.1 Importing a Project into e<sup>2</sup> studio

Follow the steps below to import your project into e<sup>2</sup> studio. Pictures may be different depending on the version of e<sup>2</sup> studio to be used.

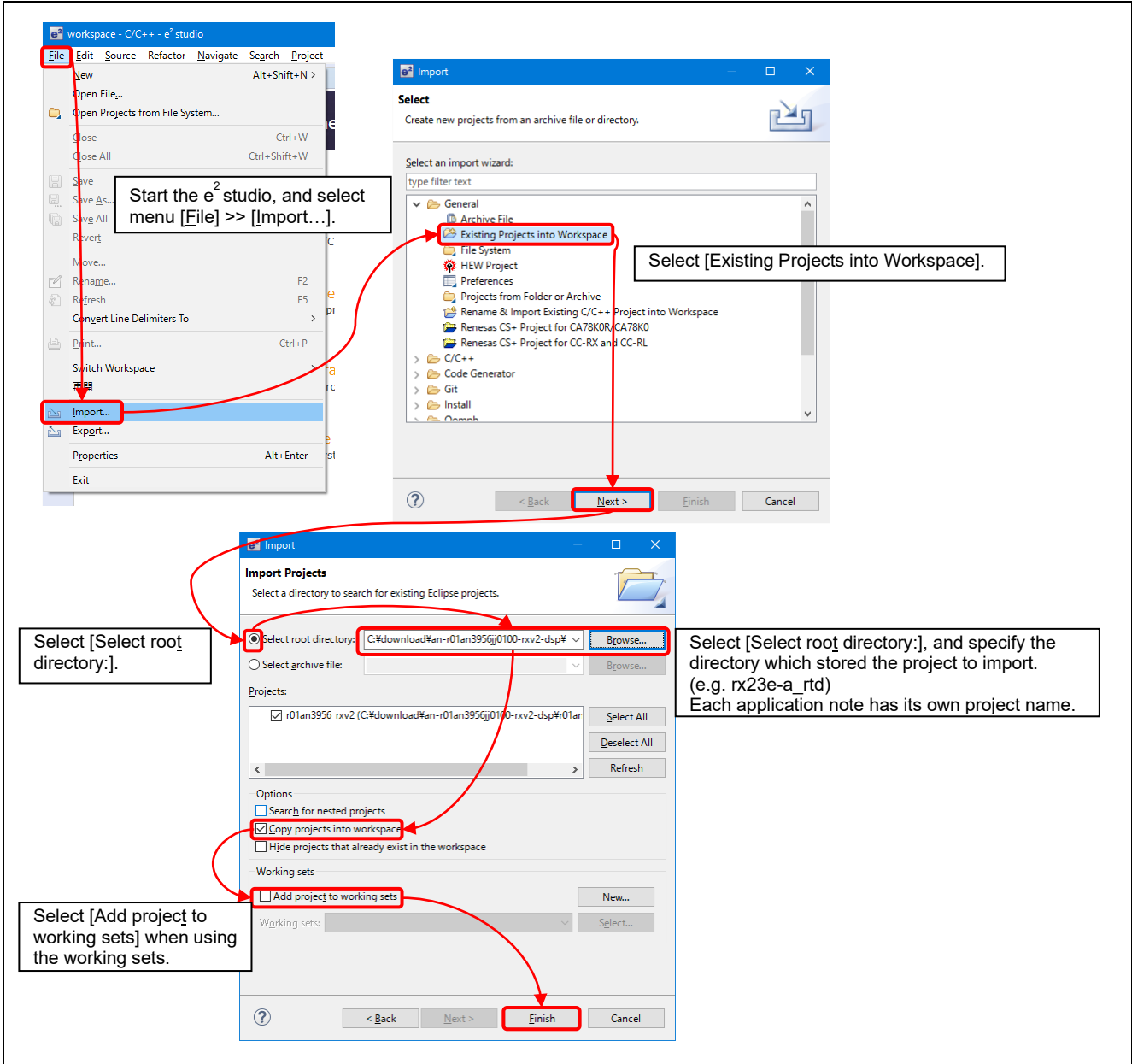

Figure 6-1 Importing a Project into e<sup>2</sup> studio

## 6.2 Importing a Project into CS+

Follow the steps below to import your project into CS+. Pictures may be different depending on the version of CS+ to be used.

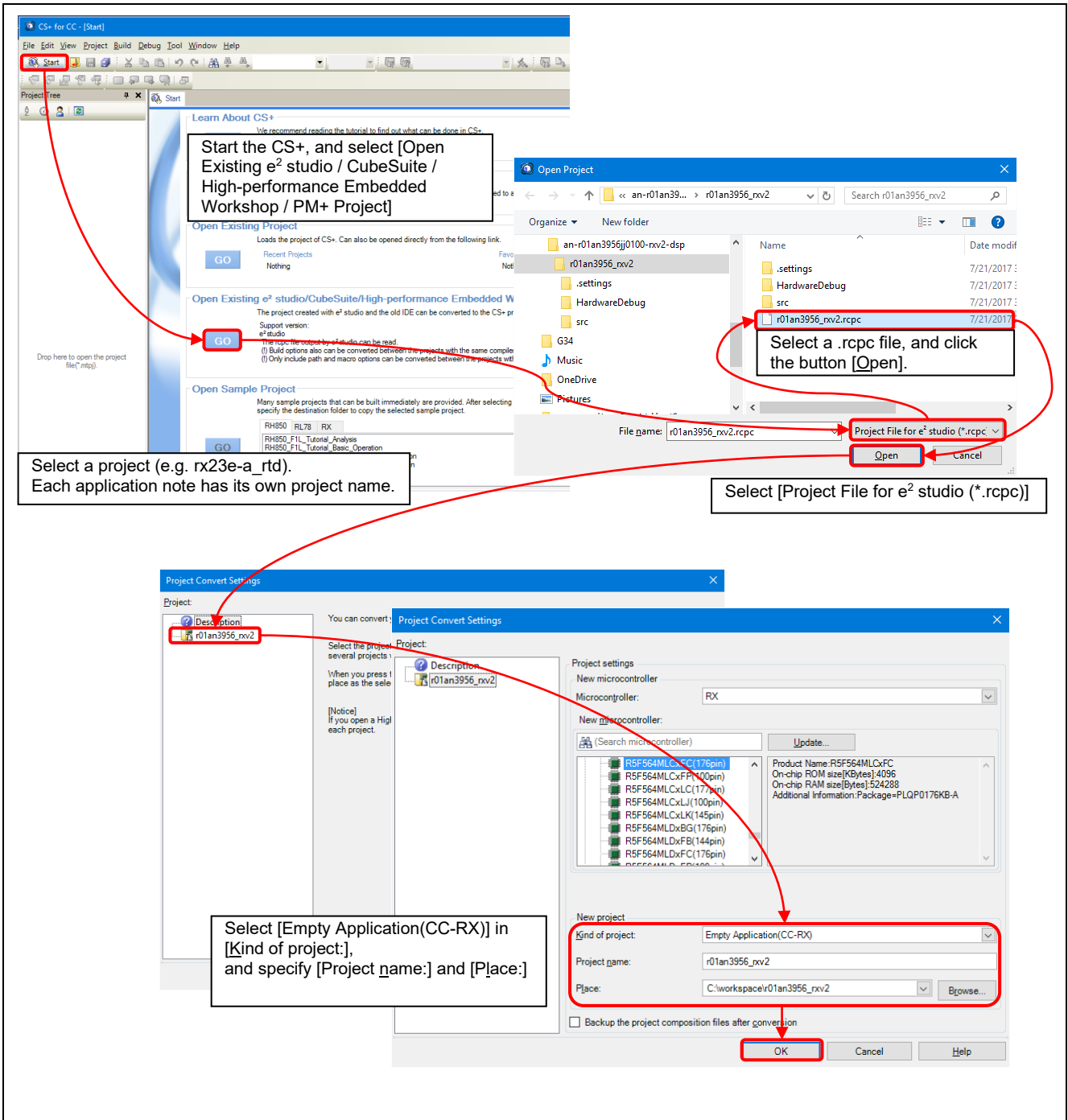

Figure 6-2 Importing a Project into CS+

## 7. Measurement Results with Sample Program

### 7.1 Memory Usage and Number of Execution Cycle

#### 7.1.1 Build Conditions

In “3 Environment for Operation Confirmation” build conditions for sample program is shown in Table 7-1. This setting is default setting when project is generated except for memory allocation to support the PC tool.

Table 7-1 Build Conditions

Item		Setting
Compiler	PC tool incompatible	-isa=rxv2 -utf8 -nomessage -output=obj -debug -outcode=utf8 -nologo
	PC tool compatible	add to the above -define=D_PRV_PC_TOOL_USE=1
Linker		-noprelink -output="rx23ea_rtd.abs" -form=absolute -nomessage -vect=_undefined_interrupt_source_isr -list=rx23ea_rtd.map -nooptimize -rom=D=R,D_1=R_1,D_2=R_2 -nologo
Additional Section		-start=B_DMAC_REPEAT_AREA_1/02000

#### 7.1.2 Memory Usage

The amount of memory usage of sample program is shown in Table 7-2.

Table 7-2 Amount of Memory Usage

Item	Size [byte]		Remarks
	PC tool incompatible	PC tool compatible	
ROM		9730	9997
	Code	6571	7018
	Data	2979	2979
RAM		7014 (2022)	12136 (7144) Note
	Data	1894	7016
	Stack	5120 (128)	5120 (128) Note

Note: RAM usage for stack is shown in “()”.

#### 7.1.3 The number of Execution Cycle

The number of execution cycles and processing load for each block in “Figure 5-1 Temperature Measurement Process Flow” is shown in Table 7-3.

Table 7-3 Number of Execution Cycle

Item	Number of Execution cycle (Execution time@ICLK=32MHz)	Process load [%]	Condition
Temperature measurement	205cycle (6.41usec)	0.006	Acquisition of A/D conversion value to temperature calculation
Communication control	348cycle (10.88usec)	0.011	Maximum number of processing cycles under normal operation

Note: Process load is calculated by the execution time in the DSAD output cycle (100msec).

## 7.2 Temperature Measurement

Results of temperature measurement with 3-wire and 4-wire RTD shown in Table 4-1 are described in this section by using RSSKRX23E-A board and sample code shown in this application note.

### 7.2.1 Measurement Condition

System configuration of temperature measurement is shown in Figure 7-1. Equipment used in the measurement is shown in Table 7-4. Measurement results were acquired with PC tool program.

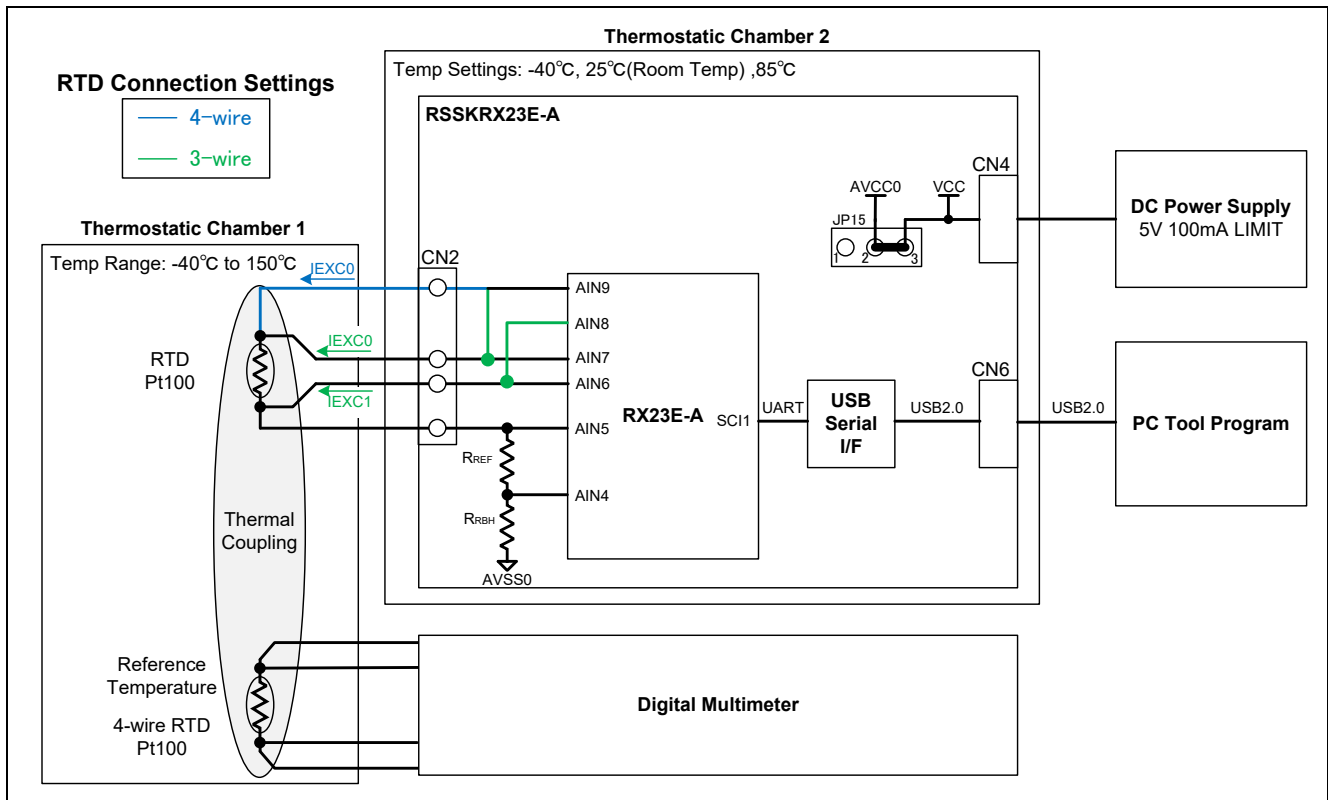

Figure 7-1 Configuration of Temperature Measurement by RTD

Table 7-4 Equipment Used in Temperature Measurement by RTD

Item	Model	Manufacturer
DC Power Supply	PCR1000MS	KIKUSUI ELECTRONICS CORPORATION
RTD Calibrator	CA330	Yokogawa Test & Measurement Corporation
Digital Multimeter	34461A	Keysight Technologies
4- Wire RTD Pt100	D00539/PS3/30/2000/PT100/CLA	Correge
Thermostatic Chamber 1	SU-241	ESPEC CORP.
Thermostatic Chamber 2	SU-240	ESPEC CORP.

### 7.2.2 Calibration

Calibration is carried out by correcting Gain/Offset of A/D conversion value with calibration, following “4.3.1. Calibration”. Condition for calibration is shown in Table 7-5.

Table 7-5 Calibration Condition

Subject	Calibration target	Condition
DSAD0	-40°C, 150°C equivalent	Board temperature : room temperature (about 25°C)



7.2.3 Measurement Results

7.2.3.1 4-wire RTD

Figure 7-2 shows measurement error  $= T - T_{REF}$  for each ambient temperature, as reference temperature  $T_{REF}$  which measured as 4-wire RTD for reference temperature, and as the measurement result  $T$ . The horizontal axis shows temperature in the thermostatic chamber and the vertical axis shows measurement error. Maximum error of Pt100 Class A is shown by the gray solid line as the guide of accuracy.

Temperature measurement result  $T$  subtracts temperature difference  $\Delta T (= T_1 - T_{REF})$  resulted from individual difference of sensors subjected to the measurement.  $T_1$  was measured by the target sensor and  $T_{REF}$  was measured by the reference sensor, using digital multimeter.

It is confirmed that RX23E-A has sufficient measurement accuracy, judging from the fact that the measurement temperature is within the error range of the sensor for each board ambient temperature.

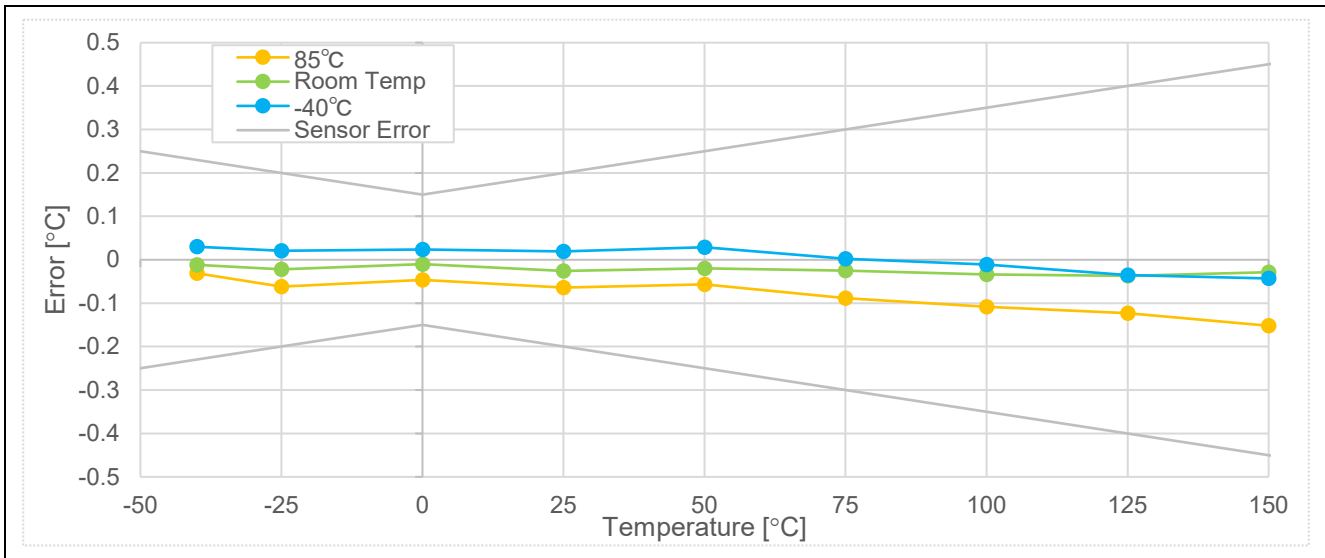

Figure 7-2 4-wire RTD Temperature Measurement Error

Histogram of deviation from average value of 1,000 samples of temperature measurement value in room temperature is shown in Figure 7-3. Temperature deviation was 0.65m°C at rms value, and 4.41m°C at P-P value. Temperature sensitivity for input voltage to RX23E-A is 192.5uV/°C, assuming that sensitivity of Pt100 is 385mΩ/°C and excitation current is 500uA, therefore, input conversion voltage is 125.8nVrms and 848.9nV at P-P value. Effective resolution and noise free resolution calculated with above-mentioned values are shown below. Although noise of RTD was added to input conversion noise of typ.:108nVrms with RX23E-A setting 10SPS and 16 times PGA gain, it shows RX23E-A is capable of highly accurate temperature measurement.

Effective resolution :	21.3bit (125.8nVrms: 0.65m°C equivalent)
Noise free resolution :	18.5bit (848.9nV: 4.41m°C equivalent)

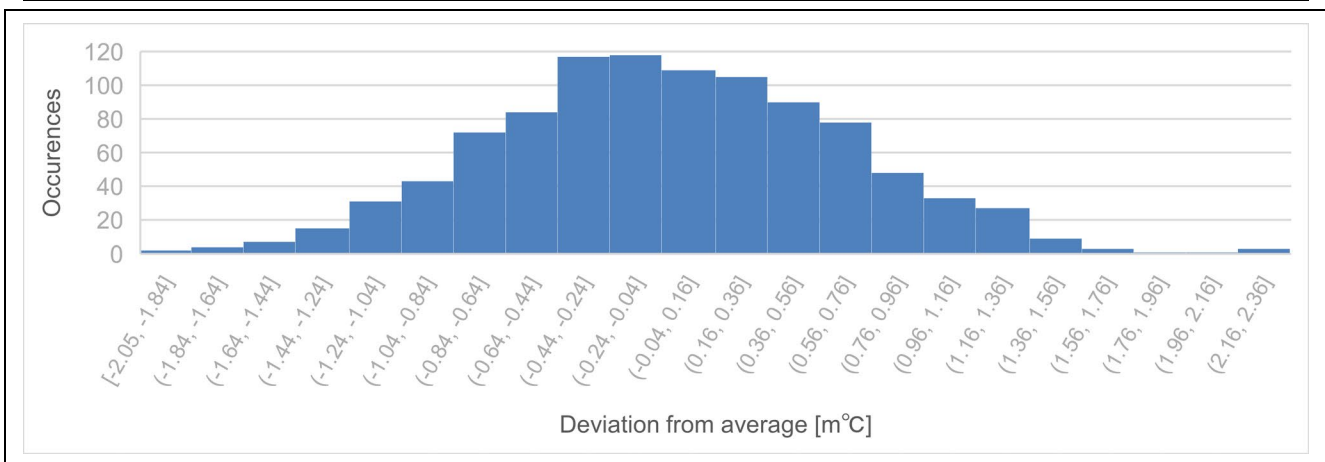

Figure 7-3 Temperature Measurement Result in Room Temperature

7.2.3.2 3-wire RTD

Figure 7-4 shows measurement error  $= T - T_{REF}$  for each ambient temperature, as reference temperature  $T_{REF}$  which measured as 3-wire RTD for reference temperature, and as the measurement result  $T$ . The horizontal axis shows temperature in the thermostatic chamber, and the vertical axis shows measurement error. Maximum error of Pt100 Class A is shown with the gray solid line as the guide of accuracy

It is confirmed that RX23E-A has sufficient measurement accuracy, judging from the fact that measurement temperature is within the error range of sensor for each board ambient temperature.

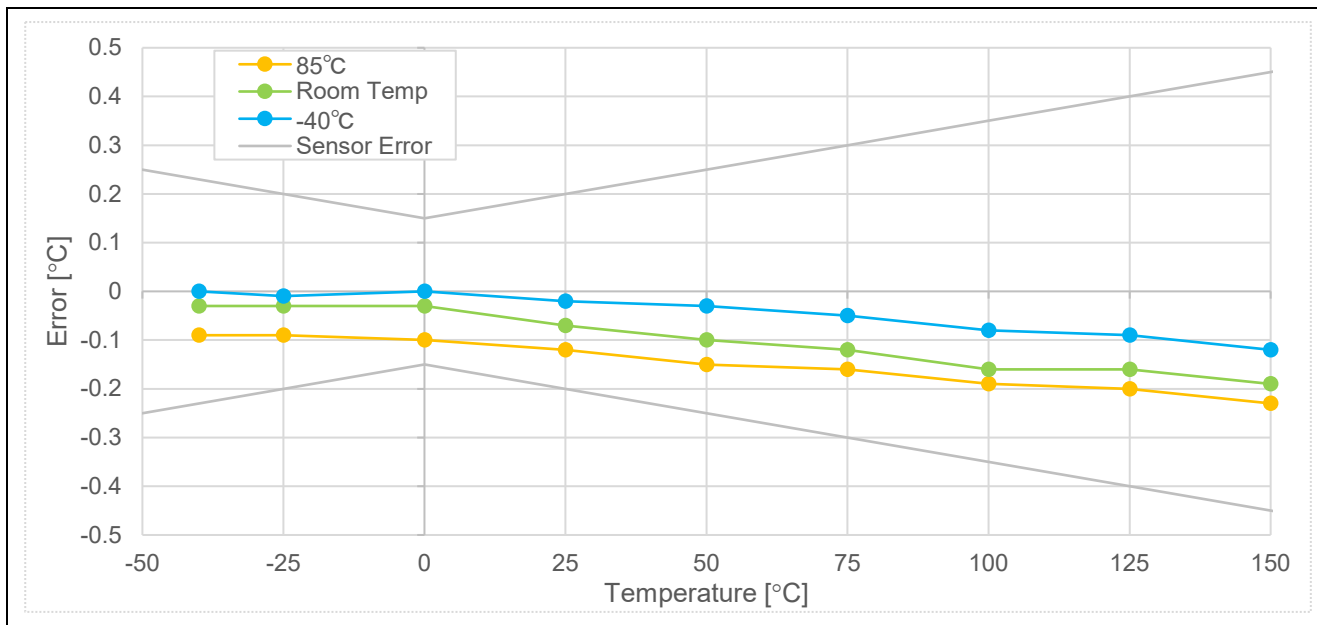

Figure 7-4 3-wire RTD Temperature Measurement Error

Histogram of deviation from average value of 1,000 samples of temperature measurement value in room temperature is shown in Figure 7-5. Temperature deviation was 1.26m°C at rms value, and 7.67m°C at P-P value. Temperature sensitivity for input voltage to RX23E-A is 96.3uV/°C, assuming that sensitivity of Pt100 is 385mΩ/°C and excitation current is 250uA, therefore, input conversion voltage is 121.2nVrms and 738.2nV at P-P value. Effective resolution and noise free resolution calculated with above-mentioned values are shown below. Although noise of RTD was added to input conversion noise of typ.:108nVrms with RX23E-A setting 10SPS and 16 times PGA gain, it shows RX23E-A is capable of highly accurate temperature measurement

Effective resolution :	21.3bit (121.2nVrms: 1.26m°C equivalent)
Noise free resolution :	18.7bit (738.2nV: 7.67m°C equivalent)

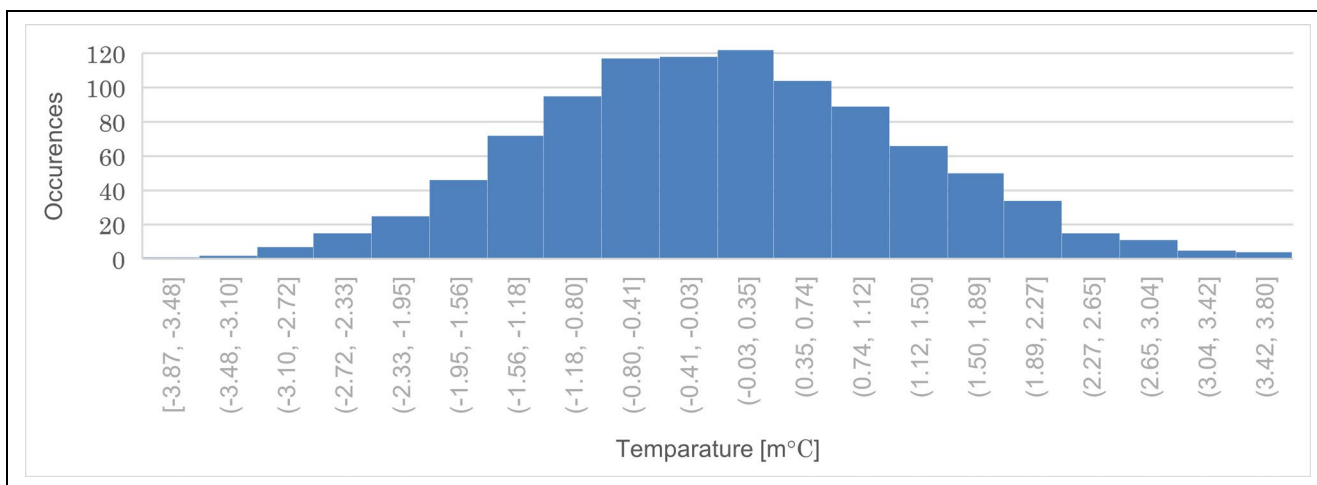

Figure 7-5 Temperature Measurement Result in Room Temperature

Revision History

Rev.	Date	Description	
		Page	Summary
1.00	Nov.28.19	-	First release
1.10	July 20.20	p.3 p.7 p.11 p.23	Table 3-1: Update of IDE and Tool Chain. 4.2Temperature Calculation Procedure: Error correction of the temperature $T_{RTD}$ formula. Table 5-3,Table 5-4: Update of the Smart Configurator setting Table 7-1,Table 7-2,Table 7-3: Modification due to the update of IDE and Tool Chain Others: Correction of the written error and addition of the description

# General Precautions in the Handling of Microprocessing Unit and Microcontroller Unit Products

The following usage notes are applicable to all Microprocessing unit and Microcontroller unit products from Renesas. For detailed usage notes on the products covered by this document, refer to the relevant sections of the document as well as any technical updates that have been issued for the products.

## 1. Precaution against Electrostatic Discharge (ESD)

A strong electrical field, when exposed to a CMOS device, can cause destruction of the gate oxide and ultimately degrade the device operation. Steps must be taken to stop the generation of static electricity as much as possible, and quickly dissipate it when it occurs. Environmental control must be adequate. When it is dry, a humidifier should be used. This is recommended to avoid using insulators that can easily build up static electricity. Semiconductor devices must be stored and transported in an anti-static container, static shielding bag or conductive material. All test and measurement tools including work benches and floors must be grounded. The operator must also be grounded using a wrist strap. Semiconductor devices must not be touched with bare hands. Similar precautions must be taken for printed circuit boards with mounted semiconductor devices.

## 2. Processing at power-on

The state of the product is undefined at the time when power is supplied. The states of internal circuits in the LSI are indeterminate and the states of register settings and pins are undefined at the time when power is supplied. In a finished product where the reset signal is applied to the external reset pin, the states of pins are not guaranteed from the time when power is supplied until the reset process is completed. In a similar way, the states of pins in a product that is reset by an on-chip power-on reset function are not guaranteed from the time when power is supplied until the power reaches the level at which resetting is specified.

## 3. Input of signal during power-off state

Do not input signals or an I/O pull-up power supply while the device is powered off. The current injection that results from input of such a signal or I/O pull-up power supply may cause malfunction and the abnormal current that passes in the device at this time may cause degradation of internal elements. Follow the guideline for input signal during power-off state as described in your product documentation.

## 4. Handling of unused pins

Handle unused pins in accordance with the directions given under handling of unused pins in the manual. The input pins of CMOS products are generally in the high-impedance state. In operation with an unused pin in the open-circuit state, extra electromagnetic noise is induced in the vicinity of the LSI, an associated shoot-through current flows internally, and malfunctions occur due to the false recognition of the pin state as an input signal become possible.

## 5. Clock signals

After applying a reset, only release the reset line after the operating clock signal becomes stable. When switching the clock signal during program execution, wait until the target clock signal is stabilized. When the clock signal is generated with an external resonator or from an external oscillator during a reset, ensure that the reset line is only released after full stabilization of the clock signal. Additionally, when switching to a clock signal produced with an external resonator or by an external oscillator while program execution is in progress, wait until the target clock signal is stable.

## 6. Voltage application waveform at input pin

Waveform distortion due to input noise or a reflected wave may cause malfunction. If the input of the CMOS device stays in the area between  $V_{IL}$  (Max.) and  $V_{IH}$  (Min.) due to noise, for example, the device may malfunction. Take care to prevent chattering noise from entering the device when the input level is fixed, and also in the transition period when the input level passes through the area between  $V_{IL}$  (Max.) and  $V_{IH}$  (Min.).

## 7. Prohibition of access to reserved addresses

Access to reserved addresses is prohibited. The reserved addresses are provided for possible future expansion of functions. Do not access these addresses as the correct operation of the LSI is not guaranteed.

## 8. Differences between products

Before changing from one product to another, for example to a product with a different part number, confirm that the change will not lead to problems. The characteristics of a microprocessing unit or microcontroller unit products in the same group but having a different part number might differ in terms of internal memory capacity, layout pattern, and other factors, which can affect the ranges of electrical characteristics, such as characteristic values, operating margins, immunity to noise, and amount of radiated noise. When changing to a product with a different part number, implement a system-evaluation test for the given product.

## Notice

1. Descriptions of circuits, software and other related information in this document are provided only to illustrate the operation of semiconductor products and application examples. You are fully responsible for the incorporation or any other use of the circuits, software, and information in the design of your product or system. Renesas Electronics disclaims any and all liability for any losses and damages incurred by you or third parties arising from the use of these circuits, software, or information.
2. Renesas Electronics hereby expressly disclaims any warranties against and liability for infringement or any other claims involving patents, copyrights, or other intellectual property rights of third parties, by or arising from the use of Renesas Electronics products or technical information described in this document, including but not limited to, the product data, drawings, charts, programs, algorithms, and application examples.
3. No license, express, implied or otherwise, is granted hereby under any patents, copyrights or other intellectual property rights of Renesas Electronics or others.
4. You shall not alter, modify, copy, or reverse engineer any Renesas Electronics product, whether in whole or in part. Renesas Electronics disclaims any and all liability for any losses or damages incurred by you or third parties arising from such alteration, modification, copying or reverse engineering.
5. Renesas Electronics products are classified according to the following two quality grades: "Standard" and "High Quality". The intended applications for each Renesas Electronics product depends on the product's quality grade, as indicated below.  
"Standard": Computers; office equipment; communications equipment; test and measurement equipment; audio and visual equipment; home electronic appliances; machine tools; personal electronic equipment; industrial robots; etc.  
"High Quality": Transportation equipment (automobiles, trains, ships, etc.); traffic control (traffic lights); large-scale communication equipment; key financial terminal systems; safety control equipment; etc.  
Unless expressly designated as a high reliability product or a product for harsh environments in a Renesas Electronics data sheet or other Renesas Electronics document, Renesas Electronics products are not intended or authorized for use in products or systems that may pose a direct threat to human life or bodily injury (artificial life support devices or systems; surgical implantations; etc.), or may cause serious property damage (space system; undersea repeaters; nuclear power control systems; aircraft control systems; key plant systems; military equipment; etc.). Renesas Electronics disclaims any and all liability for any damages or losses incurred by you or any third parties arising from the use of any Renesas Electronics product that is inconsistent with any Renesas Electronics data sheet, user's manual or other Renesas Electronics document.
6. When using Renesas Electronics products, refer to the latest product information (data sheets, user's manuals, application notes, "General Notes for Handling and Using Semiconductor Devices" in the reliability handbook, etc.), and ensure that usage conditions are within the ranges specified by Renesas Electronics with respect to maximum ratings, operating power supply voltage range, heat dissipation characteristics, installation, etc. Renesas Electronics disclaims any and all liability for any malfunctions, failure or accident arising out of the use of Renesas Electronics products outside of such specified ranges.
7. Although Renesas Electronics endeavors to improve the quality and reliability of Renesas Electronics products, semiconductor products have specific characteristics, such as the occurrence of failure at a certain rate and malfunctions under certain use conditions. Unless designated as a high reliability product or a product for harsh environments in a Renesas Electronics data sheet or other Renesas Electronics document, Renesas Electronics products are not subject to radiation resistance design. You are responsible for implementing safety measures to guard against the possibility of bodily injury, injury or damage caused by fire, and/or danger to the public in the event of a failure or malfunction of Renesas Electronics products, such as safety design for hardware and software, including but not limited to redundancy, fire control and malfunction prevention, appropriate treatment for aging degradation or any other appropriate measures. Because the evaluation of microcomputer software alone is very difficult and impractical, you are responsible for evaluating the safety of the final products or systems manufactured by you.
8. Please contact a Renesas Electronics sales office for details as to environmental matters such as the environmental compatibility of each Renesas Electronics product. You are responsible for carefully and sufficiently investigating applicable laws and regulations that regulate the inclusion or use of controlled substances, including without limitation, the EU RoHS Directive, and using Renesas Electronics products in compliance with all these applicable laws and regulations. Renesas Electronics disclaims any and all liability for damages or losses occurring as a result of your noncompliance with applicable laws and regulations.
9. Renesas Electronics products and technologies shall not be used for or incorporated into any products or systems whose manufacture, use, or sale is prohibited under any applicable domestic or foreign laws or regulations. You shall comply with any applicable export control laws and regulations promulgated and administered by the governments of any countries asserting jurisdiction over the parties or transactions.
10. It is the responsibility of the buyer or distributor of Renesas Electronics products, or any other party who distributes, disposes of, or otherwise sells or transfers the product to a third party, to notify such third party in advance of the contents and conditions set forth in this document.
11. This document shall not be reprinted, reproduced or duplicated in any form, in whole or in part, without prior written consent of Renesas Electronics.
12. Please contact a Renesas Electronics sales office if you have any questions regarding the information contained in this document or Renesas Electronics products.

(Note1) "Renesas Electronics" as used in this document means Renesas Electronics Corporation and also includes its directly or indirectly controlled subsidiaries.

(Note2) "Renesas Electronics product(s)" means any product developed or manufactured by or for Renesas Electronics.

(Rev.4.0-1 November 2017)

## Corporate Headquarters

TOYOSU FORESIA, 3-2-24 Toyosu,  
Koto-ku, Tokyo 135-0061, Japan  
[www.renesas.com](http://www.renesas.com)

## Trademarks

Renesas and the Renesas logo are trademarks of Renesas Electronics Corporation. All trademarks and registered trademarks are the property of their respective owners.

## Contact information

For further information on a product, technology, the most up-to-date version of a document, or your nearest sales office, please visit:  
[www.renesas.com/contact/](http://www.renesas.com/contact/).