

QUICKSWITCH BASICS AND APPLICATIONS

INTRODUCTION

The QuickSwitch family of FET switches was pioneered in 1990 to offer designers products for high-speed bus connection and logic replacement with sub-nano-second propagation delay, zero added noise and timing skew, and no additional static power dissipation. Since their introduction, QuickSwitch products have gained acceptance as ideal devices for hot-docking, voltage translation, capacitance isolation, logic replacement, clock gating, and several other applications.

WHAT IS A QUICKSWITCH?

In its basic form, a QuickSwitch is an N-channel FET switch controlled by either combinatorial or sequential control logic using CMOS technology. The low ON resistance (typically 5Ω), low capacitance, high current capacity, and very high OFF resistance, make the FET switch an ideal element for bus connection. Figure 1 shows the basic QuickSwitch configuration.

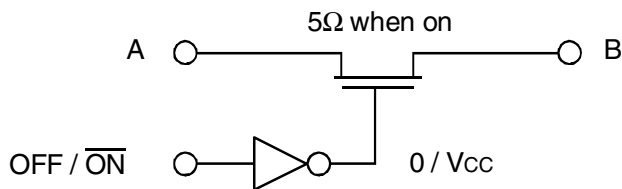

Figure 1. Basic QuickSwitch

When the switch is enabled, the gate of the N-channel switch transistor driven by a CMOS logic gate is at V_{cc} and the switch exhibits a typical ON resistance of 5Ω. When disabled, the gate of the switch is at Ground potential and the switch offers very high resistance between the A and B terminals. In the OFF state, the leakage current at the switch terminals is typically 10nA, and the capacitance between the terminals is low. Typical capacitance at the switch terminals is 5pF in the OFF state. These properties make the QuickSwitch an ideal device for unbuffered bus connection.

QUICKSWITCH ON RESISTANCE

The ON resistance of the QuickSwitch is determined by the size of the switch FET and the voltage applied to the switch terminals. The ON resistance decreases as the voltage between the switch gate and the switch terminals increases. Therefore, the switch exhibits a somewhat nonlinear ON resistance characteristics with respect to the voltage at its input terminal. Note that the FET switch is essentially bidirectional. Therefore, either of the

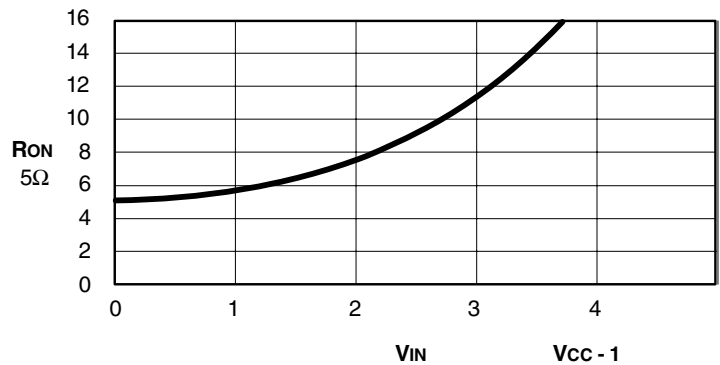

Figure 2. QuickSwitch ON Resistance vs. V_{IN}

two switch terminals can be regarded as the input, the other being the output. A plot of the ON resistance of a QuickSwitch is shown in Figure 2.

A typical QuickSwitch device has an ON resistance of less than 5Ω for input voltages near Ground. The resistance rises as the switch input voltage rises. At the TTL High voltage of 2.4V at the switch inputs, the ON resistance is typically 10Ω. As the switch input voltage rises towards V_{cc} , the switch exhibits higher ON resistance. At input voltages approaching approximately $V_{cc} - 1$, the switch enters cut-off region.

The input range also extends to 0.5V below ground. Below this voltage, the clamp diode connected to the switch terminal begins to draw current.

QUICKSWITCH WITH SERIES RESISTOR OPTION

IDT offers most QuickSwitch functions with a series resistor option. These switches have an integrated resistor of typically 23Ω value in series with the switch. To obtain the ON resistance vs. V_{IN} characteristics for a switch with the resistor option, the reader should add 23Ω to the graph in Figure 2. The series resistor serves as a source-termination resistor or a damping resistor to reduce noise caused by signals with fast transitions.

V_{OUT} vs. V_{IN} CHARACTERISTICS

The QuickSwitch provides a low resistance connection between the input and output over a wide input voltage range. Starting from V_{IN} of approximately -0.5V, the output voltage equals the input voltage. This relationship is maintained until the input voltage reaches approximately $V_{cc} - 1V$. For input voltages between $V_{cc} - 1$ and V_{cc} , the output voltage gets clipped to approximately $V_{cc} - 1$ due to the 'source-follower' configuration of the N-channel switch. The V_{IN} vs. V_{OUT} characteristics for three different output loads is shown in Figure 3.

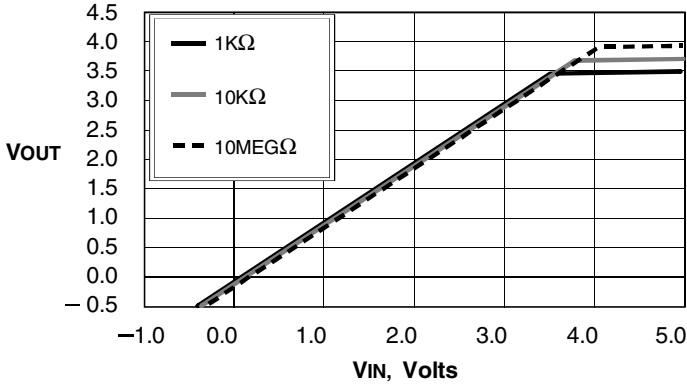

Figure 3. Typical V_{OUT} vs. V_{IN} for Various Loads

The switch develops a voltage drop across its terminals as a function of the load resistance. Because of the non-linear nature of switch resistance, the voltage drop is also non-linear as shown in Figure 4.

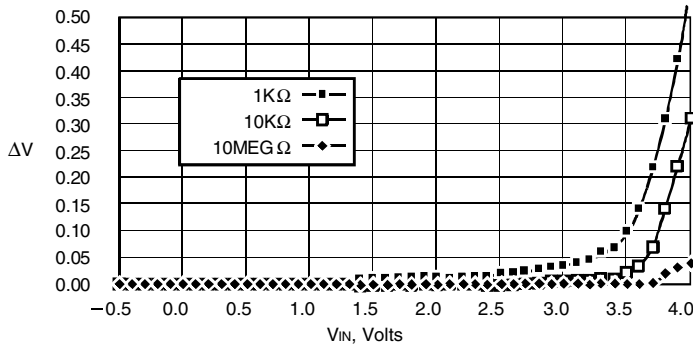

Figure 4. Typical Voltage Drop vs. V_{IN}

QUICKSWITCH V_{OUT} vs. V_{CC}

When the input voltage to the switch is at or near V_{CC} , the output voltage is approximately 1V below V_{CC} due to the "source-follower" configuration of the N-channel switch as described earlier. This voltage drop is process dependent and may vary from 1V to 1.3V. Increasing or decreasing the V_{CC} will increase or decrease the output voltage by the same amount as shown in Figure 5.

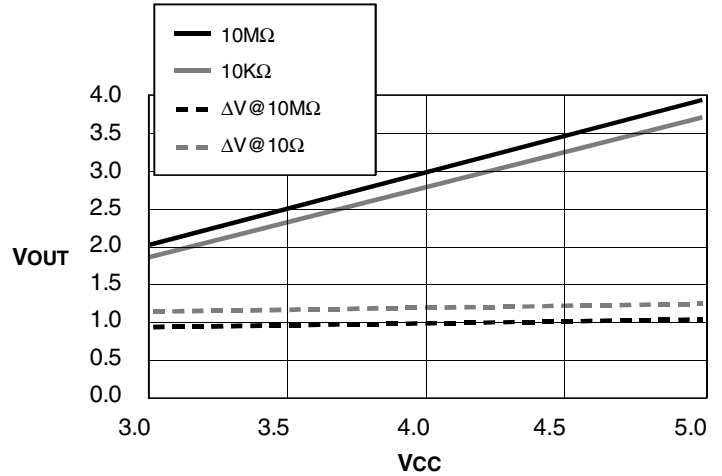

Figure 5. V_{OUT} and Voltage Drop vs. V_{CC} at $V_{IN} = V_{CC}$

The voltage drop across the switch when $V_{IN} = V_{CC}$ is substantially constant for a wide range of supply voltage. The "clipping" action at high input voltages and the negligible voltage drop across the switch at lower input voltages makes the QuickSwitch an ideal device for voltage level translation in mixed 5V/ 3.3V systems. By using the QuickSwitch at a supply voltage of approximately 4.3V between a 5V bus and a 3.3V bus, 3.3V signals can be passed to the 5V side without attenuation, and 5V signals will be clipped to 3.3V to interface safely with 3.3V circuits connected to the bus.

QUICKSWITCH OPERATION WITH TTL SIGNALS

One common application of the QuickSwitch is its use as a bus switch. Some popular devices such as QS3245 are used for replacing FCT245 or ABT245 logic functions which interface between two TTL buses. In this application the QuickSwitch performs bus connection and bus isolation with sub-nanosecond propagation delay and zero added skew and ground bounce.

Figure 6 below shows the QuickSwitch as a bus switch driven by a TTL driver at its input. The switch output is connected to CMOS inputs which offer a capacitive load to the driver through the switch.

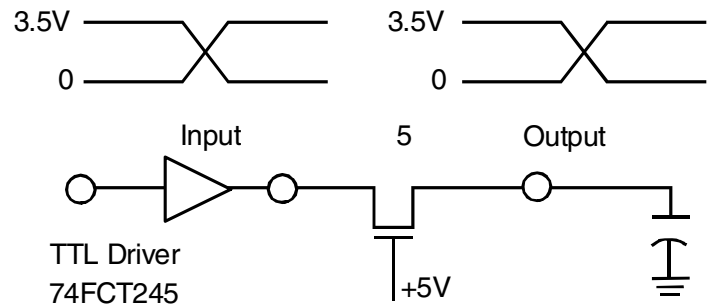

Figure 6. Bus Switch Operation

When the switch is closed, connecting the driver to its load, the gate of the N-channel FET is at V_{CC} and the switch transistor is fully ON. During the low-to-high TTL transitions at the switch input, the load capacitance will charge via the low ON resistance of the switch. Typically, a 50pF load will charge with a time-constant of 250ps through the 5Ω switch. During the high-to-low transitions, the load capacitance will discharge with the same time-constant. Since the time-constant is much less than the rise or fall time of the driver, the signal transition at the load is determined by the driver, and not by the switch. To a first approximation, the switch adds zero propagation delay. If the signal transitions at the switch input are TTL compatible, i.e. from 0 to 3.5V, these transitions are faithfully reproduced at the output with no additional noise.

When the switch is open, disconnecting the driver from the load, the gate of the N-channel FET is at 0V, and the switch transistor is OFF. The impedance between the switch terminals is extremely high. The parasitic capacitance at the switch terminals offers low AC impedance, thus minimizing signal feed-through between the switch terminals in the OFF state.

When the QuickSwitch is either powered down or is in the disabled state, there is no DC path from either switch terminal to either ground or V_{CC} for voltages above $-0.5V$. This feature makes the QuickSwitch ideal as an interface device for isolating system components during hot docking (live insertion).

The bus switch can replace drivers and transceivers in systems if bus repowering is not required. It provides no drive of its own, but relies on the driver connected to its input. For moderately capacitive loading, the QuickSwitch provides a net gain in speed because of the sub-nanosecond propagation delay through the switch, which is much smaller than the propagation delay through a buffer or a transceiver and the additional derating for the load capacitance.

QUICKSWITCH RATINGS AND SPECIFICATIONS

INTRODUCTION

In this section, the ratings, AC and DC specifications, and test method for various parameters are discussed in order to provide information and clarification to the user.

ABSOLUTE MAXIMUM RATINGS

The absolute maximum continuous ratings are those values beyond which permanent and irreversible damage to the device may occur. Exposure to these conditions or conditions beyond those indicated may adversely affect device reliability. Functional operation under absolute maximum conditions is not implied.

The **Supply Voltage** rating defines the absolute maximum V_{CC} that can be safely applied to the device. This rating is consistent with that of other TTL logic devices. The Supply Voltage rating is determined by the breakdown limits of internal components. If the V_{CC} is taken beyond the rated limit, excessive current may be drawn from the power supply due to device breakdown and permanent damage may occur due to excessive heat generated. As device dimensions are reduced to improve circuit performance, the breakdown voltage also decreases. As a rule of thumb, the absolute maximum Supply Voltage rating is normally 40% above the nominal operating supply voltage. For 5V circuits, the absolute maximum supply voltage is 7V. It is 4.6V for circuits operating at a nominal 3.3V supply. It is a prudent practice to limit even the transient supply voltage rise to the absolute maximum rating.

The **DC Input Voltage** rating is the maximum voltage that can be applied to the TTL control inputs of a QuickSwitch device. Since IDT's QuickSwitch devices are designed without a clamp diode to V_{CC} to enable hot insertion, the DC input voltage may exceed V_{CC} provided it is less than the rated voltage. This rating is also determined by the breakdown characteristics of internal components.

The **DC Switch Voltage** is maximum voltage that can be applied to the switch terminals. For all devices which use an N-channel FET switch, the rated switch voltage is the same as the rated input voltage. For devices that use N-FET and P-FET combination, the absolute maximum switch voltage is limited to 0.5V above V_{CC} to prevent damage to the circuit due to excessive current flow through the parasitic diode associated with the P-channel FET.

The **AC Input Voltage** applies to the transient voltage (for example, voltage undershoot) at the TTL control input or switch input. It states that pulses of up to $-3V$ can be tolerated for a duration less than 20ns without damaging the device. However, large undershoots can cause significant clamp current and local heating. If the transient pulses have a high duty cycle, the average power dissipation must be taken into account to ensure that the average DC current and power dissipation do not exceed the rated values.

The **DC Switch Current** per pin defines the maximum current that can be drawn through the switch in ON state to pull down an external load to ground.

The **Power Dissipation** defines the maximum total power dissipation capability of the device. It represents the package power dissipation limit based on the thermal time constant for the package/die combination and the maximum permissible chip junction temperature. The total power dissipation is the sum of static and dynamic dissipation components.

The **Storage Temperature** rating defines the extremes of temperature range that a package may be subjected to for long term storage, even the power being applied to the device.

INPUT AND SWITCH CAPACITANCE

Each control input pin and switch pin has a capacitance associated with it. The capacitance at a control input is due to the package and the input circuitry connected to the pin. It is package dependent and typically ranges from 3pF to 5pF.

The switch pins have two capacitance values—one for the OFF state and one for the ON state, as shown in Figure 7. In the OFF state, each switch pin is isolated and has a capacitance to ground. The capacitance in this state is the sum of pin capacitance and the total capacitance associated with the switches connected to the pin. For example, an individual switch in the QS3384 device will have a lower capacitance than the Mux pin of QS3253 Dual 4:1 Mux/Demux.

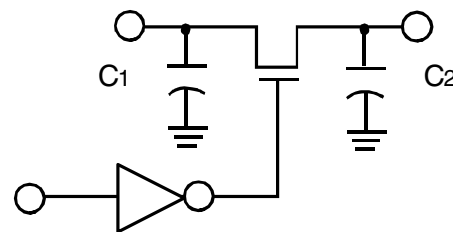

Figure 7. Switch Capacitance

In the ON state, the low impedance switch connects both ends of the switch, and the capacitance seen at one pin is the sum of the capacitances at the two pins. If multiple switches connected to a pin are ON at the same time (i.e. in the case of Crossbar products), the capacitance seen at the pin is the sum of all pin capacitances connected by the ON switches.

DC ELECTRICAL CHARACTERISTICS

The DC electrical characteristics define the input operating conditions for proper operation, responses to applied DC signals, and Switch characteristics over specified voltage and temperature range. Limits of all DC electrical characteristics are guaranteed over the recommended operating temperature and power supply range as stated in the data-sheets for individual products.

V_{IH} and V_{IL} define the limits of guaranteed logic HIGH and logic LOW recognition levels at the control inputs. For example, V_{IH} limit of 2.0V implies that any voltage greater than 2.0V shall be recognized by the input circuit as a logic HIGH. Similarly, V_{IL} limit of 0.8V implies that any voltage less than 0.8V shall be recognized as logic LOW. Typical applied input voltages are between 3.5V and V_{CC} for logic HIGH and between 0V and 0.5V for logic LOW, thus assuring adequate noise margin. Note that the AC characteristics are guaranteed for input signal swing of 0V to 3.0V.

I_{IN} defines the input leakage current at the control inputs of a QuickSwitch. The typical input leakage current is of the order of 1 to 5nA at room temperature.

I_{OZ} defines the maximum leakage current at the switch pin in OFF state. The typical switch leakage current is also of the order of 1 to 5nA at room temperature, indicating the excellent Off-isolation characteristics of the QuickSwitch devices.

R_{ON} defines the resistance offered by a switch in the ON state. Since the resistance is a function of the input voltage applied to the switch, it is normally specified at two different values of input voltage. R_{ON} is measured by forcing the specified amount of current through the switch as shown in Figure 8. It is calculated by taking the ratio of voltage drop across the switch and the current forced through the switch.

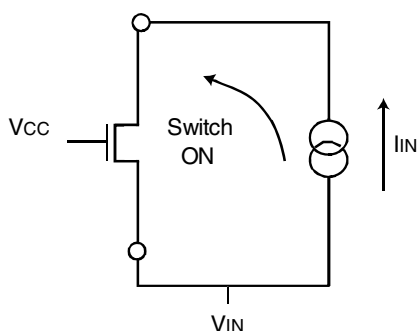

Figure 8. QuickSwitch R_{ON} Measurement

R_{ON} increases with the applied input voltage. The relationship between R_{ON} and V_{IN} is nonlinear and the ON resistance begins to increase significantly as V_{IN} approaches V_{CC} .

The Pass Voltage, V_P , relates to the output voltage "clipping" feature of the N-channel QuickSwitch when the switch input voltage is equal to or greater than the supply voltage. This feature is used in the 5V/3.3V translation applications. V_P is measured at the switch output at $I_{OUT} = -5\mu A$ when the switch input is held at V_{CC} . Typical voltage drop across the switch under these conditions is 1V, thus giving a typical V_P of 4V.

POWER SUPPLY CHARACTERISTICS

The Power Supply characteristics define the components of power supply current under normal operating conditions.

I_{CC0} is the Quiescent (static) power supply current when all control inputs are at logic LOW or HIGH levels and the switches are OFF. This current represents the leakage current between the V_{CC} and Ground pins of a QuickSwitch device. It will also include DC current through the device due to a resistive path from V_{CC} to Ground, if applicable.

ΔI_{CC} is the power supply current component per each TTL control input when the input is in logic HIGH state. It represents the current through the input stage.

Q_{CCD} is the dynamic power supply current component expressed in terms of mA or mA per MHz. This current is measured with switch pins open and switching the control inputs with 50% duty cycle, so that it measures only the current required to switch the internal nodes of the circuit. Note that measured value of dynamic supply current at a given frequency includes the I_{CC0} component which needs to be subtracted to obtain the Q_{CCD} value.

SWITCHING CHARACTERISTICS

The switching characteristics discussed below relate specifically to the switches. Other parameters such as set-up and hold times, release times, clock pulse width etc. have the same meaning and interpretation as those in logic circuits, and are excluded from the following discussion.

Data Propagation Delay parameters, t_{PLH} and t_{PHL} , refer to the delay through the switch in ON state. Since the switch behaves like a low value resistor, the propagation delay is related to the RC time-constant $R_{ON} \times C_L$, where C_L is the load capacitance. The time-constant is of the order of 250ps for $R_{ON} = 5\Omega$ and $C_L = 5pF$. Note that the time-constant is of the order of 1.4ns for QuickSwitch devices with resistor options with typical $R_{ON} = 28\Omega$.

Switch Turn-on Delay specifications, t_{PZL} and t_{PZH} , define the time taken to cross nominal TTL threshold of 1.5V at the switch output when the switch turns on in response to the control signal.

Switch Turn-off Delay specifications, t_{PLZ} and t_{PHZ} , define the time taken to place the switch in high-impedance OFF state in response to the control signal. Since the output is undriven in the OFF state, external load must be used to move the output away from the previous logic state in order to create a measurable voltage change at the output. The turn-off delay is the time taken for the output voltage to change by 300mV from the original quiescent level, with reference to logic level transition at the control input.

AC Test Conditions

The AC test conditions used for the verification and guarantee of switching characteristics follow industry-accepted practices for high-performance standard logic products.

Control signals for changing the state of the switches transition between ground and 3.0V with a rise or fall time of 2.5ns measured between 10% and 90% points.

The AC test circuit for 5-volt products is shown in Figure 9. The inputs under test are driven by a pulse generator with a source impedance of 50 Ω . The output load consists of a 50pF capacitance (including jig and probe capacitance) and a resistor network. The 500 Ω resistance to ground normally consists of a 450 Ω discrete resistor in series with the 50 Ω impedance of the co-ax probe which offers very low capacitance for accurate measurements.

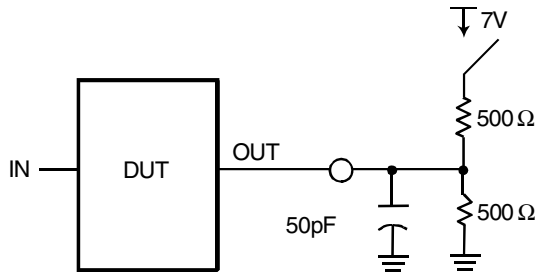
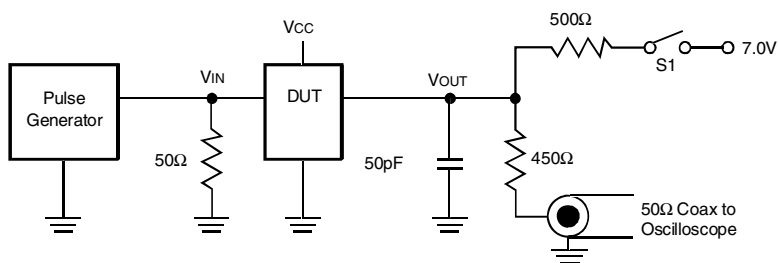

Figure 9. AC Test Circuit for 5V Products

For all tests except t_{PLZ} and t_{PZL} , the switch connected to the 7-volt supply is open. The AC load is the parallel combination of 50pF and 500Ω.

To perform the t_{PHZ} and t_{PZH} tests, the switch shown in Figure 9 is connected to the 7V supply. This creates an "artificial" logic HIGH level when the QuickSwitch is in the OFF state, so that output voltage transitions can occur during logic LOW to high-impedance state when the switch is undriven.

TEST CIRCUIT AND WAVEFORMS



LOAD SWITCH POSITION

Parameter	S1 Position
t_{PLH} , t_{PHL}	Open
t_{PZH} , t_{PHZ}	Open
t_{PZL} , t_{PLZ}	Closed

INPUT CONDITIONS: Input Voltage = 0V to 3V, t_r , t_f = 2.5ns (10% to 90%), R_L = 500Ω, C_L = 50pF

PROPAGATION DELAY

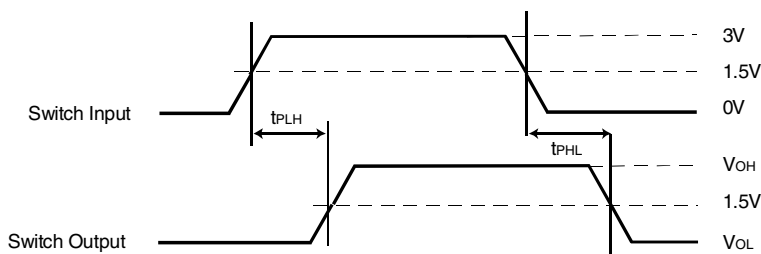

ENABLE AND DISABLE TIMES

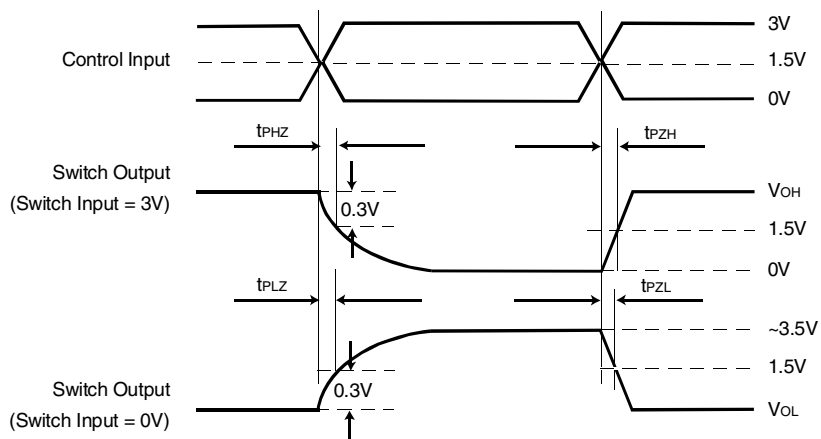

NOTES:

1. t_{PLH} and t_{PHL} : Data propagation delays through the switch when the Switch is ON.
2. t_{PZH} : The output goes from Hi-Z (Switch OFF) to a High State (Switch ON).
3. t_{PZL} : The output goes from Hi-Z (Switch OFF) to a Low State (Switch ON).
4. t_{PLZ} : The output goes from Low State (Switch ON) to a Hi-Z (Switch OFF).
5. t_{PHZ} : The output goes from High State (Switch ON) to a Hi-Z (Switch OFF).

IMPORTANT NOTICE AND DISCLAIMER

RENESAS ELECTRONICS CORPORATION AND ITS SUBSIDIARIES (“RENESAS”) PROVIDES TECHNICAL SPECIFICATIONS AND RELIABILITY DATA (INCLUDING DATASHEETS), DESIGN RESOURCES (INCLUDING REFERENCE DESIGNS), APPLICATION OR OTHER DESIGN ADVICE, WEB TOOLS, SAFETY INFORMATION, AND OTHER RESOURCES “AS IS” AND WITH ALL FAULTS, AND DISCLAIMS ALL WARRANTIES, EXPRESS OR IMPLIED, INCLUDING, WITHOUT LIMITATION, ANY IMPLIED WARRANTIES OF MERCHANTABILITY, FITNESS FOR A PARTICULAR PURPOSE, OR NON-INFRINGEMENT OF THIRD PARTY INTELLECTUAL PROPERTY RIGHTS.

These resources are intended for developers skilled in the art designing with Renesas products. You are solely responsible for (1) selecting the appropriate products for your application, (2) designing, validating, and testing your application, and (3) ensuring your application meets applicable standards, and any other safety, security, or other requirements. These resources are subject to change without notice. Renesas grants you permission to use these resources only for development of an application that uses Renesas products. Other reproduction or use of these resources is strictly prohibited. No license is granted to any other Renesas intellectual property or to any third party intellectual property. Renesas disclaims responsibility for, and you will fully indemnify Renesas and its representatives against, any claims, damages, costs, losses, or liabilities arising out of your use of these resources. Renesas' products are provided only subject to Renesas' Terms and Conditions of Sale or other applicable terms agreed to in writing. No use of any Renesas resources expands or otherwise alters any applicable warranties or warranty disclaimers for these products.

(Disclaimer Rev.1.0 Mar 2020)

Corporate Headquarters

TOYOSU FORESIA, 3-2-24 Toyosu,
Koto-ku, Tokyo 135-0061, Japan
www.renesas.com

Contact Information

For further information on a product, technology, the most up-to-date version of a document, or your nearest sales office, please visit:
www.renesas.com/contact/

Trademarks

Renesas and the Renesas logo are trademarks of Renesas Electronics Corporation. All trademarks and registered trademarks are the property of their respective owners.