

Application Note

A Boost Converter Design for Energy Harvesting Applications. Part 2

AN-CM-217

Abstract

Addendum to “A Boost Converter Design for Energy Harvesting Applications” explains the difference between Li-Ion charging and Lead-Acid charging.

This application note comes complete with design files which can be found in the References section.

A Boost Converter Design for Energy Harvesting Applications. Part 2
Contents

Abstract	1
Contents	2
Figures	2
1 Terms and Definitions	3
2 References	3
3 A Boost Converter Design for Energy Harvesting Applications	4
Revision History	6

Figures

Figure 1: Schematic-Level Addition for Li-Ion Charging.....	4
Figure 2: GreenPAK Designer changes for Li-Ion charging	5

A Boost Converter Design for Energy Harvesting Applications. Part 2

1 Terms and Definitions

ACMP	Analog comparator module
GPIO	General-purpose input/output
Li-ion	Lithium-ion
NAND gate	Negative-AND, a logic gate which produces an output which is false only if all its inputs are true; thus its output is complement to that of the AND gate

2 References

For related documents and software, please visit:

<https://www.dialog-semiconductor.com/configurable-mixed-signal>.

Download our free **GreenPAK™** Designer software [1] to open the .gp files [1] and view the proposed circuit design. Use the **GreenPAK** development tools [3] to freeze the design into your own customized IC in a matter of minutes. Renesas Electronics provides a complete library of application notes [4] featuring design examples as well as explanations of features and blocks within the IC.

- [1] [GreenPAK Designer Software](#), Software Download and User Guide, Renesas Electronics
- [2] [AN-CM-217 A Boost Converter Design for Energy Harvesting Applications. Part 2.gp](#), [GreenPAK](#) Design File, Renesas Electronics
- [3] [GreenPAK Development Tools](#), [GreenPAK](#) Development Tools Webpage, Renesas Electronics
- [4] [GreenPAK Application Notes](#), [GreenPAK](#) Application Notes Webpage, Renesas Electronics
- [5] “BU-409: Charging Lithium-ion”, Battery University, 2017-05-09
- [6] “A Designer's Guide to Lithium (Li-ion) Battery Charging”, Article Library of Digi-Key Electronics, 2016-09-01
- [7] AN-1202 A Boost Converter Design for Energy Harvesting Applications (Part1), Application Note, Renesas Electronics

A Boost Converter Design for Energy Harvesting Applications. Part 2
3 A Boost Converter Design for Energy Harvesting Applications

It is useful to compare Li-Ion charging with Lead-Acid charging. The traditional lead-acid battery charge cycle has Bulk (often but not necessarily Constant Current), Absorb (Constant Voltage) and Float (Constant Voltage) phases. It is important to complete the charge cycle by running it through all three phases. Li-Ion battery charging differs from lead-acid charging in the following aspects:

- There is no Float phase – charging current must drop to zero once Absorption is complete; completion of Absorption is signaled by the charge current dropping to below 0.1C
- If charging is stopped before Absorption is complete, the battery life does not worsen as with lead acid batteries; in fact cutting short the Absorption phase or eliminating it altogether actually improves the battery life [5]
- Deeply discharged Li-Ion batteries need a trickle charge of 0.1C to make them ready for the Bulk phase
- Slow charging simplifies matters. From [6]: “the quicker the charge, the lower the capacity when the battery switches to the relatively slow constant-voltage part of the charging regime. For example, charging at 0.7 C results in a capacity of 50 to 70 percent when 4.1 or 4.2 V is reached, whereas charging at less than 0.2 C can result in a full battery as soon as the voltage reaches 4.1 or 4.2 V.”

A general-purpose Li-Ion charger therefore needs a fair amount of logic to take care of these different battery states and properties. However, things become interesting in the specific context of energy harvesting. Application Note AN-1202 [7] presents a boost converter for energy harvesting applications. This Note features a battery that is used to support the system when harvested energy runs low. What if we wanted a rechargeable Li-Ion battery here? Since we are dealing with loads that are not power hungry, it is more important to have extended battery life rather than have a battery charged to exactly 100% of capacity. This allows us to exploit property (b) above.

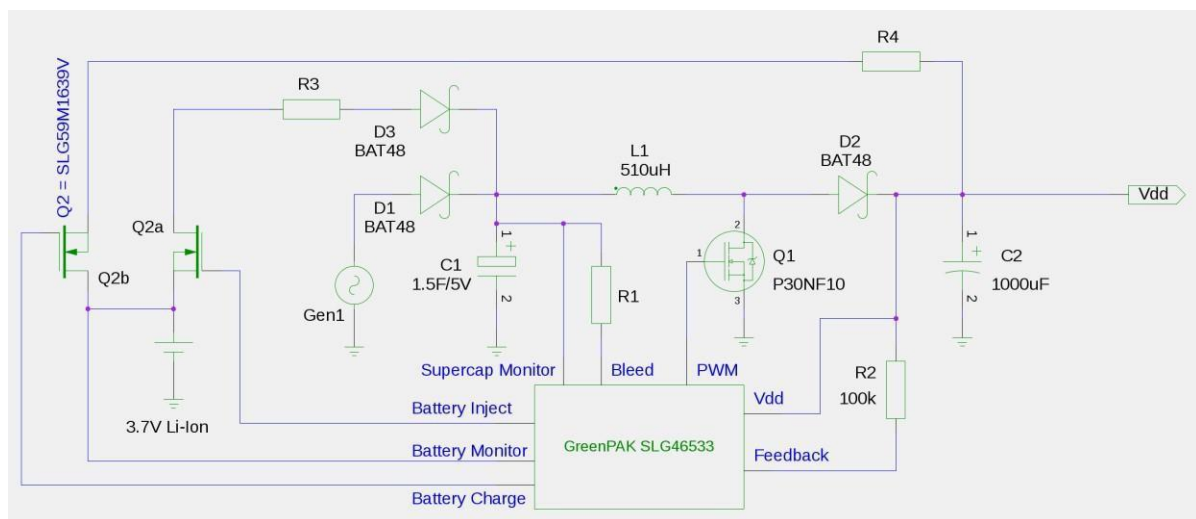

Figure 1: Schematic-Level Addition for Li-Ion Charging

Further, charging currents being low, we can also exploit property (d). These effectively imply that the Absorption phase offers no advantage and can be dispensed with. As long as we make a reasonable assumption that the Li-Ion battery will not be over-discharged (or design specifically for it), then (c) is also rendered largely irrelevant. Consequently, we are left with only the Bulk phase to contend with. Therefore, we can quite easily incorporate Li-Ion battery charging capability into the design presented in AN-1202 with the addition of a single resistor R4 and a GreenFET Q2b as shown in Figure 1, which will be controlled by the GreenPAK via the GPIO line marked Battery Charge. The additional piece conveniently operates off the 5V output!

(The single GreenFET in AN-1202 has been replaced by a dual GreenFET here.) When Q2b is on, the battery charges via the 5 V output of the system. The value of R4 must be chosen so that the overall load is small enough to not cause excessive output ripple; it should at any rate be no more than 0.1 C. Q2b is turned on via the Battery Charge GPIO pin only when the supercap is fully charged,

A Boost Converter Design for Energy Harvesting Applications. Part 2

and the battery is not fully charged. If the battery as well as supercap are fully charged, harvested energy is bled away as before through R1. The change in the bleed logic is implemented by modifying the associated GreenPAK Designer diagram as shown.

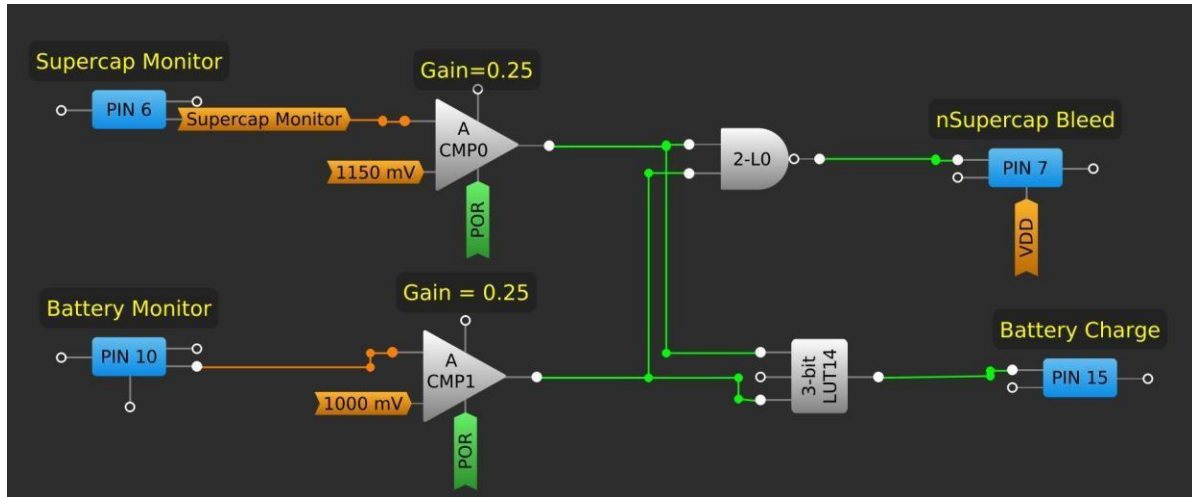

Figure 2: GreenPAK Designer changes for Li-Ion charging

We now need an additional ACMP to monitor the battery voltage. In [Figure 2](#) this is ACMP1 which is configured with a hysteresis of 200 mV so that when the battery voltage is above 4 V, it is deemed full enough and when it falls below 3.2 V it flags the need for charging. The supercap voltage is monitored by ACMP0. NAND gate L0 bleeds the supercap when the supercap and battery are both charged, whereas LUT14 outputs a high to turn on Q2b to charge the battery when the battery voltage is below 3.2 V and the supercap is fully charged.

(Note: In comparing [Figure 2](#) of AN-1202 and [Figure 2](#) in this Addendum, it will be evident that some ACMP labels have changed; this is because some ACMPs cannot be configured independently of others. For this reason, a few GPIO assignments are also different

IMPORTANT NOTICE AND DISCLAIMER

RENESAS ELECTRONICS CORPORATION AND ITS SUBSIDIARIES (“RENESAS”) PROVIDES TECHNICAL SPECIFICATIONS AND RELIABILITY DATA (INCLUDING DATASHEETS), DESIGN RESOURCES (INCLUDING REFERENCE DESIGNS), APPLICATION OR OTHER DESIGN ADVICE, WEB TOOLS, SAFETY INFORMATION, AND OTHER RESOURCES “AS IS” AND WITH ALL FAULTS, AND DISCLAIMS ALL WARRANTIES, EXPRESS OR IMPLIED, INCLUDING, WITHOUT LIMITATION, ANY IMPLIED WARRANTIES OF MERCHANTABILITY, FITNESS FOR A PARTICULAR PURPOSE, OR NON-INFRINGEMENT OF THIRD PARTY INTELLECTUAL PROPERTY RIGHTS.

These resources are intended for developers skilled in the art designing with Renesas products. You are solely responsible for (1) selecting the appropriate products for your application, (2) designing, validating, and testing your application, and (3) ensuring your application meets applicable standards, and any other safety, security, or other requirements. These resources are subject to change without notice. Renesas grants you permission to use these resources only for development of an application that uses Renesas products. Other reproduction or use of these resources is strictly prohibited. No license is granted to any other Renesas intellectual property or to any third party intellectual property. Renesas disclaims responsibility for, and you will fully indemnify Renesas and its representatives against, any claims, damages, costs, losses, or liabilities arising out of your use of these resources. Renesas' products are provided only subject to Renesas' Terms and Conditions of Sale or other applicable terms agreed to in writing. No use of any Renesas resources expands or otherwise alters any applicable warranties or warranty disclaimers for these products.

(Rev.1.0 Mar 2020)

Corporate Headquarters

TOYOSU FORESIA, 3-2-24 Toyosu,
Koto-ku, Tokyo 135-0061, Japan
www.renesas.com

Contact Information

For further information on a product, technology, the most up-to-date version of a document, or your nearest sales office, please visit:
www.renesas.com/contact/

Trademarks

Renesas and the Renesas logo are trademarks of Renesas Electronics Corporation. All trademarks and registered trademarks are the property of their respective owners.