

White Paper

Reduce Size, Weight and Power of Telecommunication Payload and Satellite Command/Telemetry Subsystems

Allan Robinson, Applications Engineer, Renesas Electronics Corp.

May 2019

Introduction

By the end of 2018, there were nearly 2,000 satellites in orbit, serving both military and commercial customers [1]. Their missions span a wide range of functions including reconnaissance, surveillance, imaging, signal intelligence, meteorology, navigation, and TV and voice communications. With every new mission, customers increasingly want more functionality, which requires larger satellite payloads, and that forces manufacturers to increase the size, weight and power (SWaP) of their satellite command and telemetry systems.

This white paper discusses how using the ISL72814SEH 16-channel driver circuit IC and the ISL71841SEH multiplexer simplifies the design of next-generation telecommunication payload systems and satellite command / telemetry subsystems. Examining these components reveals that they reduce footprint size by up to 50%, while doubling the number of telemetry data inputs and command outputs. Also, we'll discuss the basic operation of the command output circuit and its role in the overall telemetry system. We'll also compare the 16-channel driver IC to an 8-channel device and show how it significantly decreases circuit size.

Figure 1 shows a block diagram for a satellite telecommunication payload system. Telecommunication payload systems use many RF switches to route the RF signal from the receiver to the output of the antenna or from the payload output; e.g. imaging, to the antenna. The RF switch count can be 1,500 per satellite. Figure 2 shows a block diagram for a next generation command and telemetry subsystem that typically has hundreds of telemetry inputs and command outputs. The 16-channel driver array controls the relays and solenoids used to route the telecommunication signals, turns the propulsion system thrusters on and off to change orbital altitude, configures payload waveguide and coax switches, and turns on a motor to tilt the solar panels.

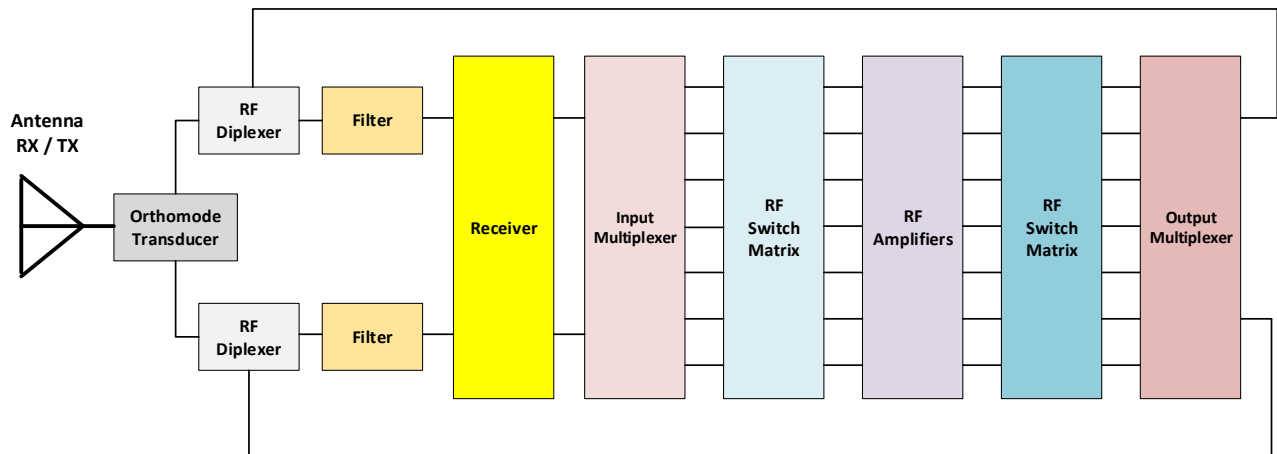

Figure 1. Block diagram of a telecommunication payload system

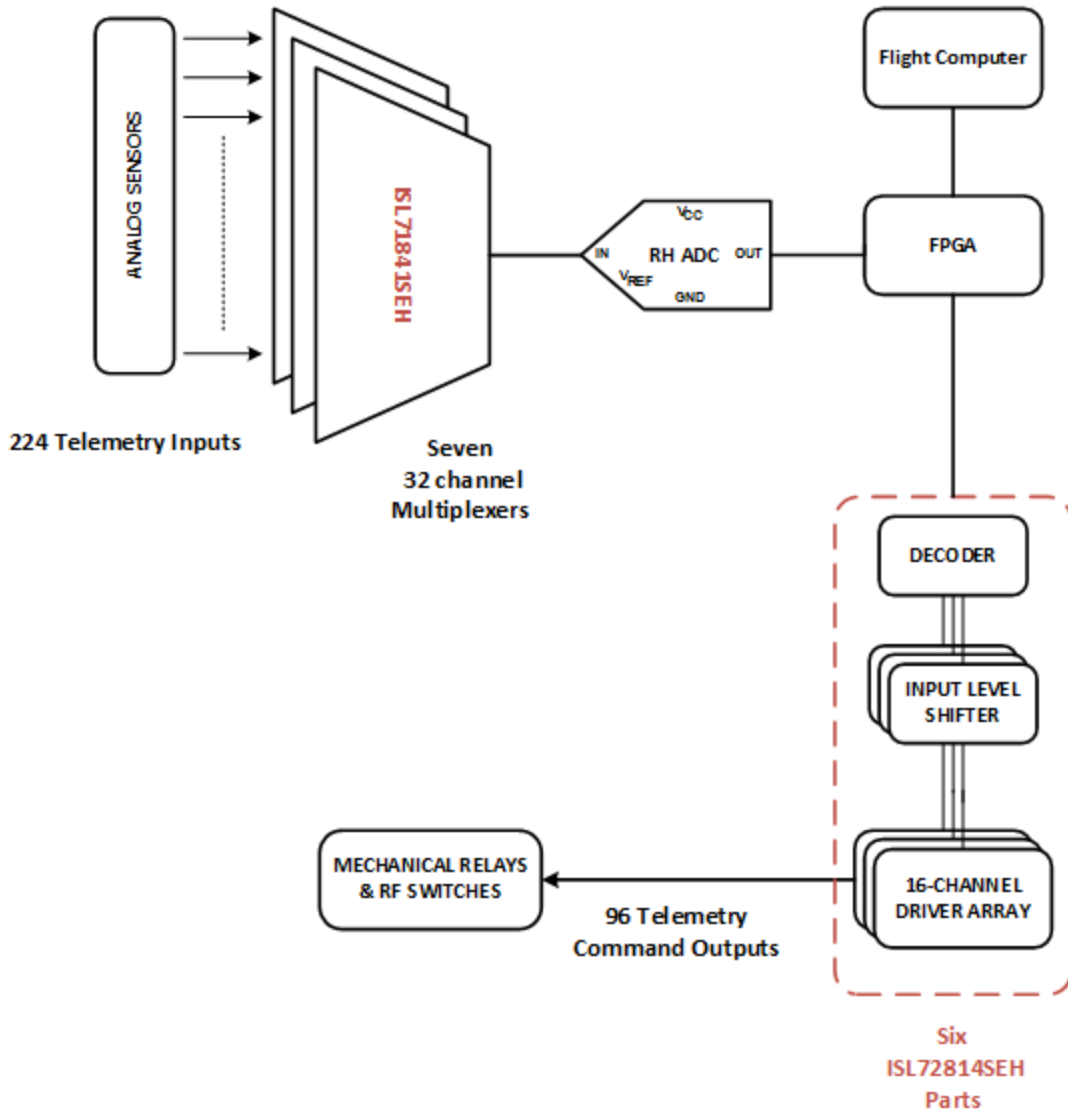

Figure 2. Block diagram of next-generation command and telemetry subsystem

The ISL72814SEH 16-channel driver circuit IC drives the coils of relays and solenoids of the RF waveguide / coaxial switches that require up to 700mA of current and +28Vdc across their coils. RF switches and relays are common components used in spacecraft and satellite telecommunication, payload, and command control output subsystems. The logic inputs to the ISL72814SEH are TTL/CMOS compatible, allowing easy interface to CPUs, FPGAs, or μ Processors. The logic inputs can also be driven as high as 13.2V to allow the ability to use a single supply when driving the new emerging 12V latching switches.

Operation of the Control Command Output Circuit

Figure 3 shows the block diagram of the satellite's command output circuit.

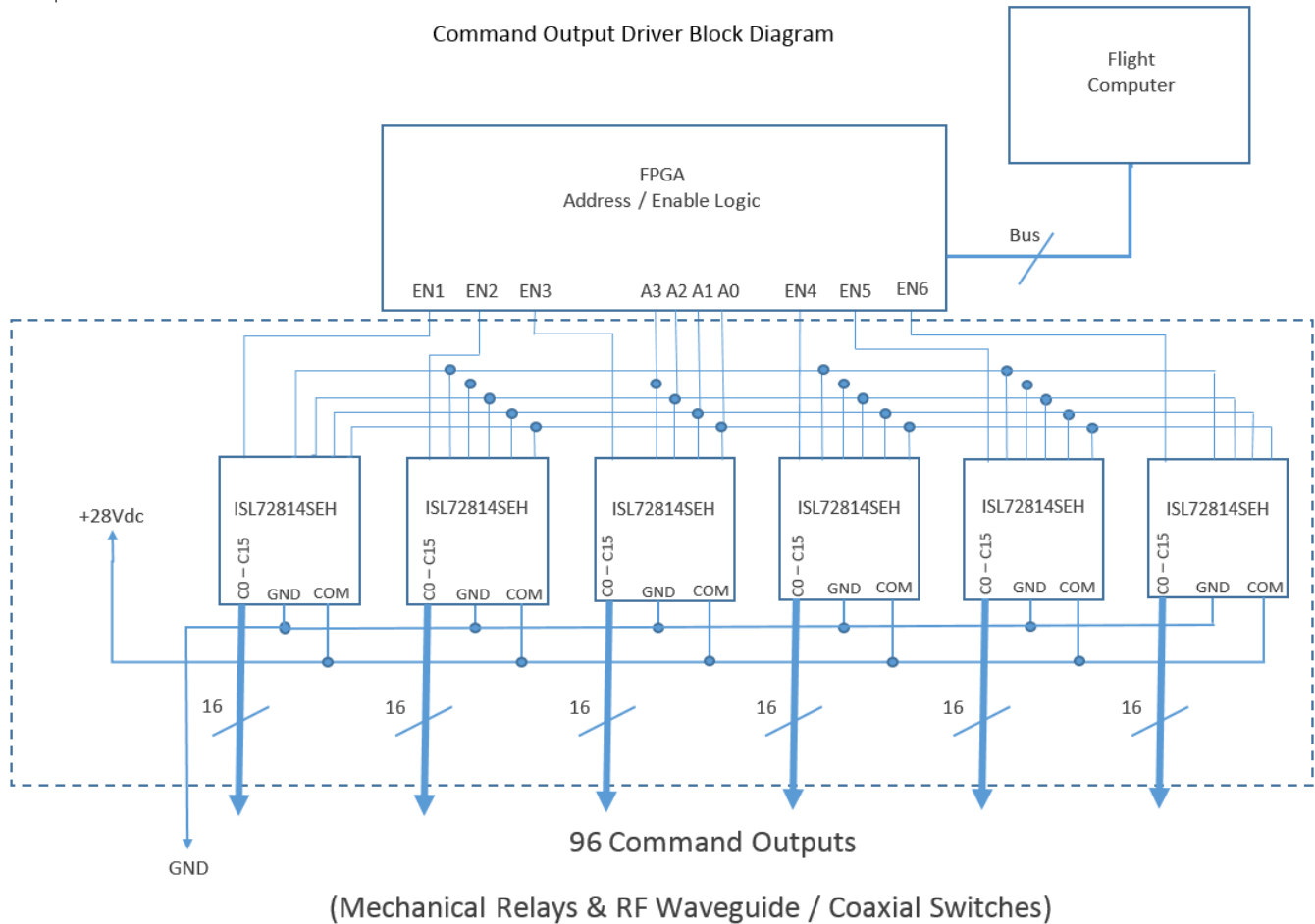

Figure 3. Block diagram of command output circuit

The circuit consists of six ISL72814SEH driver ICs that allow for 96 command outputs. Each output goes to the coil of either a relay or to the solenoid of an RF waveguide / coaxial switch that requires up to +28Vdc across their solenoid coils to activate their main circuit. A relay coil draws < 100mA of current, while an RF waveguide/coaxial switch coil can draw up to 700mA of current. The commands from these devices are used to control the communications payload and other subsystems in the spacecraft.

Power for the relay and switch coils are provided by a positive +4.5Vdc to +28Vdc power source connected at the relay / solenoid positive coil terminal with the ISL72814SEH channel output connected at the negative coil terminal. The +28Vdc source provides up to 700mA to power the relay / solenoid coils.

An ISL72814SEH device has four logic inputs (A0 – A3) to select one of the 16 driver channels and an enable pin that can be used to disable all the 16 channels when driven low. Each of the (A0 – A3) logic pins of the six ISL72814SEH drivers are connected in parallel as shown in Figure 3 and connected to four of the FPGA's logic outputs. Each enable pin of the six drivers go to a separate FPGA output logic pin. Only one channel of an ISL72814SEH's 16 channels can be activated at a time; however, it is possible to turn on up to six channels simultaneously by driving all six of the enable pins high.

When a specific driver channel is commanded by the flight computer to be activated, the FPGA will apply the appropriate logic signals to select and enable the channel. It then holds the enable pin high for a specific time, powering that channel to momentarily drive the channel's load.

The application only requires 10 logic outputs from the FPGA to control the 96 command outputs. The logic inputs of the six ISL72813SEH devices respond to TTL logic levels and the FPGA drives them directly with 3.3V or 5V logic.

An ISL72814SEH device on each of its 16 driver channels has an internal kickback clamping diode connected to the COM pin of the part. The kickback diode clamps any inductive transient voltage generated at a channel by preventing the channel voltage from exceeding the COM voltage by more than the clamp diode forward voltage (V_F), which for a current of 700mA, has a maximum V_F of 2.25V. Each of the COM pins of the six ISL72814SEH drivers are connected in parallel, as shown in Figure 3, and connected to the 28Vdc power supply, which is the highest DC coil voltage of the system. During channel switching of the 96 channels, the inductive voltage generated at a channel drawing 700mA will be no more than 30.25V.

Advantages of the New Design

Older designs use discrete one-input to one-output current driver arrays to build the payload and command output subsystem. A single driver array IC contains, at most, eight Darlington current drivers in a 20-lead LCC package. To use the driver array ICs in an application requires external logic decoding circuitry, external level shifting circuitry, and external blocking diodes at each of the Darlington inputs and outputs. The diodes at the input and output side of the Darlington drivers are required due to the high leakage current of the drivers when in the off state. The level shifting circuit provides the required 6V to the base of a Darlington driver to turn it on when selected by the 3V logic signal from the decoder. A separate level shifting circuit is required for each driver input. One level shifting circuit can consist of two resistors and one transistor.

Figure 4 shows the components and circuitry replaced by one ISL72814SEH part, which replaced two discrete current driver array ICs. Also eliminated were 32 blocking diodes and 16 level shifting circuits, which consisted of 32 resistors, 16 transistors, and a pair of decoder ICs that are used to select one of the 16 level shifting circuits. Note that for a circuit card with 96 command outputs, six ISL72814SEH parts would replace 12 discrete driver array parts, 96 blocking diodes, six 3x8 decoders, and 96 level shifting circuits, which includes 192 resistors and 96 transistors. The new output design offers more than a 2:1 footprint reduction over the old design.

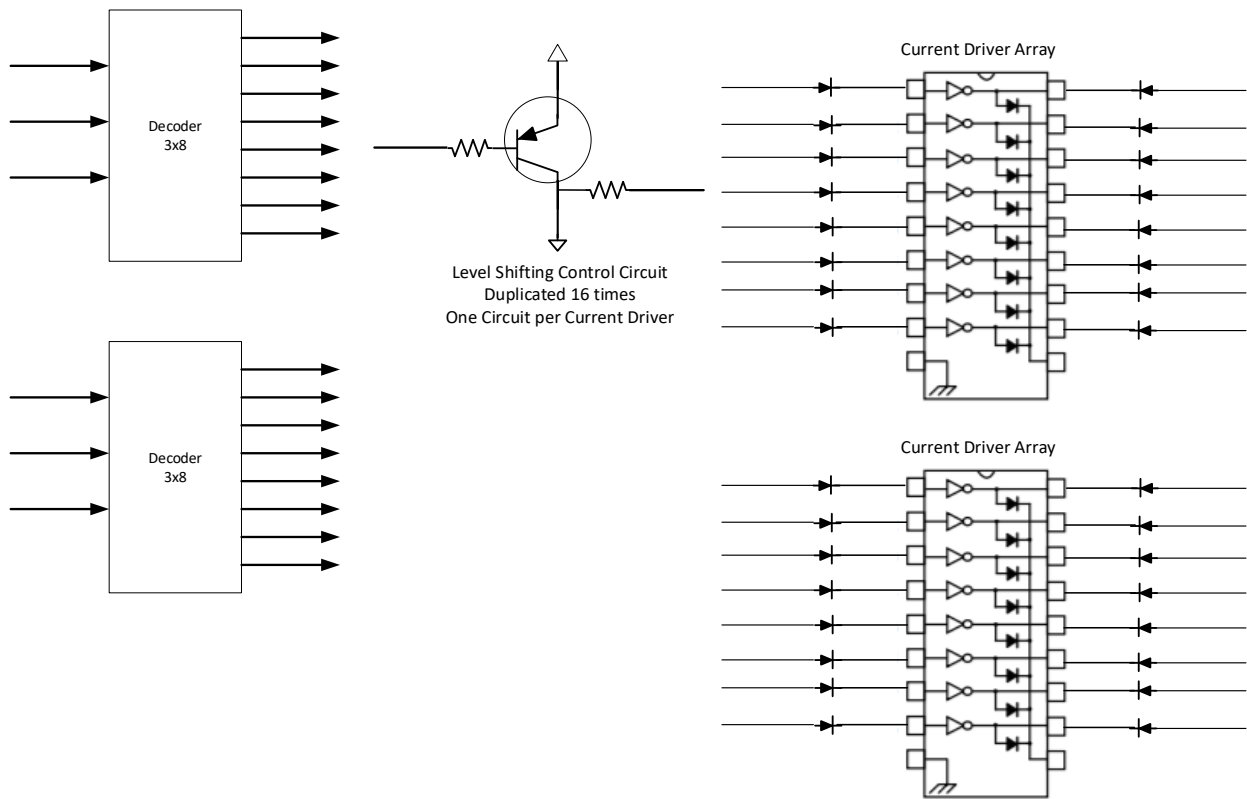

Figure 4. Components replaced by one ISL72814SEH part

Figure 5 shows the ISL72814SEH functional block diagram. It is a radiation-hardened 16-channel high-voltage, high-current driver circuit with an integrated level shifter and 4-bit to 16-bit logic decoder. The decoder selects one of the 16 available driver channels, and its enable pin can disable all 16-channels. The device integrates 16 high-current drivers that feature high-voltage, common-collector, and open-emitter PNP outputs with a 42V breakdown voltage and peak current rating of 700mA. In addition to the 16 driver channels and the level shifting circuitry to reference the output base of a selected channel to a positive voltage, the ISL72814SEH's five logic pins control the 16 drivers, which eliminates the 3x8 decoders and 16 level shifters used in the old design. The part features very low off-channel leakage of only 90nA maximum, which eliminates the 96 blocking diodes needed in the old design. The logic inputs are TTL/CMOS compatible, allowing easy interface to CPUs, FPGAs, or μ Processors. The logic inputs can also be driven as high as 13.2V to allow the ability to have a single supply when driving the new emerging 12V latching switches. On each of its 16 driver channels, an ISL72814SEH device has an internal kickback clamping diode connected to the COM pin of the part. The kickback diode clamps any inductive transient voltage generated at a channel by preventing the channel voltage from exceeding the COM voltage by more than the clamp diode forward voltage (VF), which for a current of 700mA has a maximum VF of 2.25V.

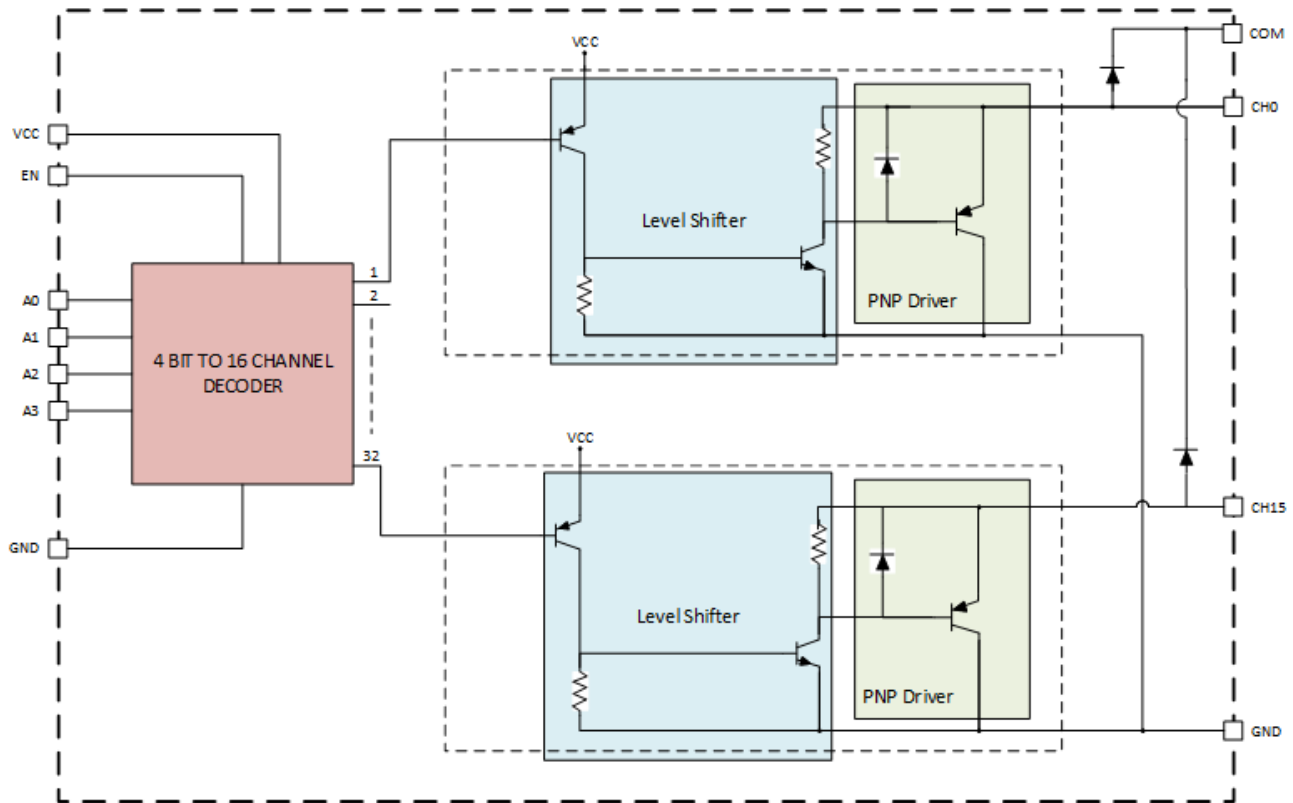

Figure 5. ISL72814SEH functional block diagram

Benefits of New Telemetry System Design

- One ISL72814SEH replaces two discrete current driver array ICs, 32 blocking diodes, address decoding, and level shifting control circuits for more than a 2:1 footprint reduction.
- Higher integration with the new Intersil devices enables a 2x increase in the number of telemetry inputs and command outputs. The reduced size of the command and telemetry subsystem improves the ratio of bus equipment to payload equipment on a spacecraft. This improves the satellite performance, since the payload is the source of revenue for a communication satellite.
- The ISL72814SEH at 500mA has a VCE (SAT) voltage limit of 1.35V vs. the Darlington driver's limit of 2.1V @ 500mA. The lower VCE (SAT) rating of the ISL72814SEH reduces the overhead voltage to drive the coil load and minimizes power dissipation by almost 40%. The ISL72814SEH has a maximum current rating of 700mA, while the Darlington driver has a maximum rating of 600mA.
- The ISL72814SEH's integrated decoder simplifies the logic control circuitry required by the old design built with 1-input to 1-output driver arrays. The ISL72814SEH can be controlled by 3.3V or 5V logic levels and accepts logic levels as high as 13.2V.
- The ISL72814SEH has very low OFF channel leakage current of 90nA max vs. 100µA for the Darlington driver. This eliminates 32 external blocking diodes and reduces voltage glitches that can be present on lightly-loaded Darlington outputs of the old design.
- The ISL72814SEH drives the relay and switch coils that typically require +28Vdc commonly used in spacecraft and satellite applications. The device's open-emitter PNP output channels can operate over a voltage range of 5V to 34V with an ABS voltage limit up to +42V terrestrial and +34V in the space environment.
- The ISL72814SEH enable function allows multiple devices to be easily cascaded together to achieve the desired number of command outputs.
- The ISL72814SEH has integrated clamp diodes on each channel to suppress inductive transient voltages to a safe level during switching of inductive loads. Its integrated clamp diodes eliminate the need for additional protection circuitry when driving inductive loads.

Radiation Hardened for Mission Assurance

Space radiation effects on electronic devices are an important system design consideration. They can cause problems ranging from operational malfunctions to severe physical damage to the devices and possibly a catastrophic mission failure.

ICs are susceptible to two types of space radiation effects caused by electrons and protons trapped in the terrestrial magnetic field: total ionizing dose (TID) and single-event effects (SEE). TID effects are the result of accumulated exposure to ionizing radiation. SEE are the result of a single high-energy particle that strikes the device.

The total dose radiation (TID) exposure is measured in rads. The term rad (radiation-absorbed dose) quantifies the total radiation exposure of a material. One rad(Si) is equal to 10×10^{-6} W of energy absorbed per gram of silicon. The total dose radiation threshold of a device is the minimum level of rad(Si) that will cause device failure. Typical commercial devices can survive around 5krads before functional failure occurs.

SEE events are significantly more hazardous to the satellite. The intense proton and heavy ion environment encountered in space applications can cause a variety of SEE in electronic circuitry, including single-event upset (SEU), single-event transient (SET), single-event functional interrupt (SEFI), single-event gate rupture (SEGR), and single-event burnout (SEB). SEE can lead to system-level performance issues including disruption, degradation, and destruction. For predictable and reliable space system operation, individual electronic components should be characterized to determine their SEE response.

TID testing on the ISL72814SEH was done to 100krad(Si) at a high dose rate of 50rad(Si)/s to 300rad(Si)/s and to 75krad(Si) at a low dose rate of 0.01rad(Si)/s under biased and grounded conditions. These tests were followed by a biased anneal at 100°C for 168 hours as outlined in MIL-STD-883 Test Method 1019. No rejects to SMD parametric limits were encountered. All parameters showed excellent stability over irradiation, with no observed dose rate or bias sensitivity. The ISL72814SEH device has a high dose rate guarantee of 100krads and a low dose rate guarantee of 75krads.

The SEE testing of the ISL72814SEH part was intended to find the limits of the VCC and VCHx supply voltages for avoiding destructive SEB at a linear energy transfer (LET) of 86 MeV•cm²/mg (gold). In addition, testing was done to look for significant SETs impacting the driver channel activity at LET of 86 MeV•cm²/mg (gold), 28 MeV•cm²/mg (krypton) and 20 MeV•cm²/mg (copper). Single-event latch-up (SEL) was not an explicit consideration since the part is manufactured in a dielectrically isolated process.

Summary of SEE testing results

- No SEL: Manufactured on Intersil's proprietary PR40 Silicon-On-Insulator (SOI) process ensures single-event latch-up immunity.
- No SEB for ions with LET ≤ 86 MeV•cm²/mg with VCC = 15V and VCHx = 34V with a case temperature of +125°C.
- SET between 1 μ s and 5.3 μ s duration beyond a 30V deviation (300mA) of an OFF channel detected for LET = 86 MeV•cm²/mg to a maximum cross section of 4400 μ m².
- SET of between 1 μ s and 39 μ s duration at 500mA conduction voltage of +100mV deviation above the switch nominal saturation voltage of an ON channel detected for LET = 28 MeV•cm²/mg to a maximum cross section of 4900 μ m².
- SET error rate estimates for a GEO orbit are shown in the table below. Error Rate Estimate Assumptions: Ions of all elements (atomic number 1 to 92) with a minimum energy value ≥ 0.1 MeV/nuc were included. A solar-quiet condition of Solar Minimum (Cosmic-Ray Maximum), and a shielding thickness of 100mils of Aluminum were assumed.

ISL72814SEH SET Error Rates

Condition	Worst Case Saturated Cross Section (μm^2)	LET (Mev*cm ² /mg)	Errors/device/year
CH OFF	4400	86	2.934E-01
CH ON	4900	28	3.272E-01

Conclusion

The ISL72814SEH is the industry's first radiation-hardened, high-voltage, high-current driver circuit to integrate the decoder, level shifter, and 16-channel driver array in a single monolithic IC, allowing satellite manufacturers to reduce command and telemetry subsystem solution size by 50%. The device offers a 2x higher density channel count compared to the nearest competitor, and the integration of the decoder and level shifter circuitry eliminates many peripheral discrete components.

The device is specifically designed to drive RF switches, relays, waveguide switches, and coaxial switches that are commonly used in spacecraft applications. The ISL72814SEH device allows satellite and spacecraft manufacturers to reduce the size of their command and telemetry subsystem by half, reducing mass, cost, and power, also known as SWaP. This allows customers to accommodate increased payload size by reducing the footprint and mass of bus components. Since the payload generates the revenue from the satellite, this is a win/win improvement for the satellite manufacturer and their customers.

References

[1] UCS Satellite Database (<https://www.ucsusa.org>)

Next Steps

- [Learn more about the ISL72814SEH](#)
- [Download the Datasheet](#)
- [Download the SEE and ELDRS TID Reports](#)

© 2019 Renesas Electronics America Inc. (REA). All rights reserved. Bluetooth is a registered trademark of Bluetooth SIG, Inc., U.S.A. Renesas is licensed to use this trademark. All other trademarks and trade names are those of their respective owners. REA believes the information herein was accurate when given but assumes no risk as to its quality or use. All information is provided as-is without warranties of any kind, whether express, implied, statutory, or arising from course of dealing, usage, or trade practice, including without limitation as to merchantability, fitness for a particular purpose, or non-infringement. REA shall not be liable for any direct, indirect, special, consequential, incidental, or other damages whatsoever, arising from use of or reliance on the information herein, even if advised of the possibility of such damages. REA reserves the right, without notice, to discontinue products or make changes to the design or specifications of its products or other information herein. All contents are protected by U.S. and international copyright laws. Except as specifically permitted herein, no portion of this material may be reproduced in any form, or by any means, without prior written permission from Renesas Electronics America Inc. Visitors or users are not permitted to modify, distribute, publish, transmit or create derivative works of any of this material for any public or commercial purposes.