

USECASE 4 #1

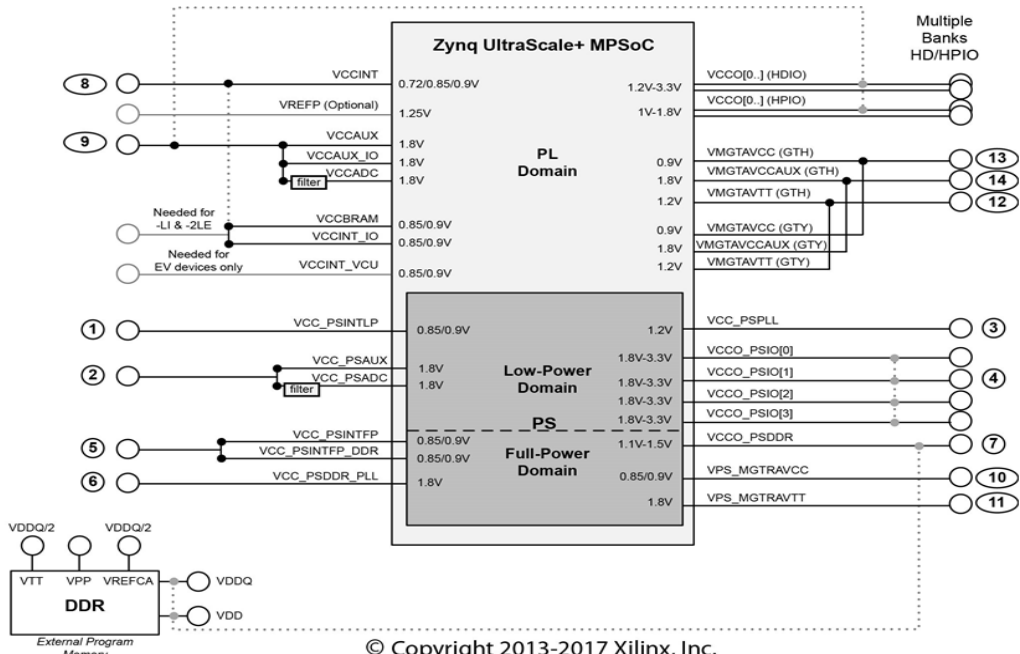

© Copyright 2013-2017 Xilinx, Inc.
All Rights Reserved.

Rail	Voltage	Power Supply Rails
Rail 1	0.85V	VCC_PSINTLP
Rail 2	1.8V	VCC_PSAUX, VCC_PSADC
Rail 3*	1.2V*	VCC_PSPLL
Rail 4	1.8-3.3V	VCCO_PSIO
Rail 5	0.85/0.9V	VCC_PSINTFP, VCC_PSINTFP_DDR
Rail 6*	1.8V*	VCC_PSDDR_PLL
Rail 7	1.1-1.5V	VCCO_PSDDR
Rail 8*	0.85V	VCCINT_VCU, VCCINT, VCCINT_I, VCBRAM
Rail 9*	1.8V	VCCAUX, VCCAUX_IO, VCCADC, DDR_VPP1
Rail 10*	0.85V*	VPS_MGTRAVCC
Rail 11*	1.8V*	VPS_MGTRAVTT
Rail 12*	1.2V	VMGTAVTT(GTH), VMGTAVTT(GTY)
Rail 13*	0.9V	VMGTAVCC(GTH), VMGTAVCC(GTY)
Rail 14*	1.8V	VMGTAVCCAUX(GTH), VMGTAVCCAUX(GTY)
Rail 16	1.2-3.3V	HDIO_VCCO
Rail 17	1-1.8V	HPIO_VCCO

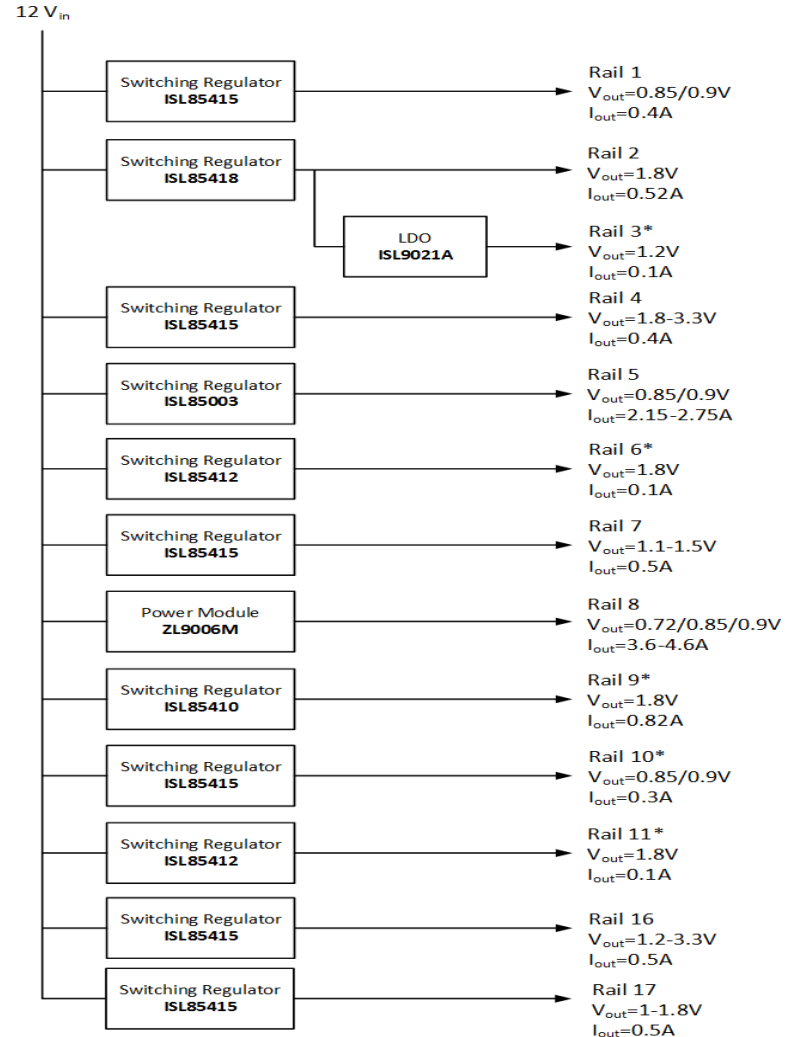

ISL85415 SINGLE OUTPUT (500mA)

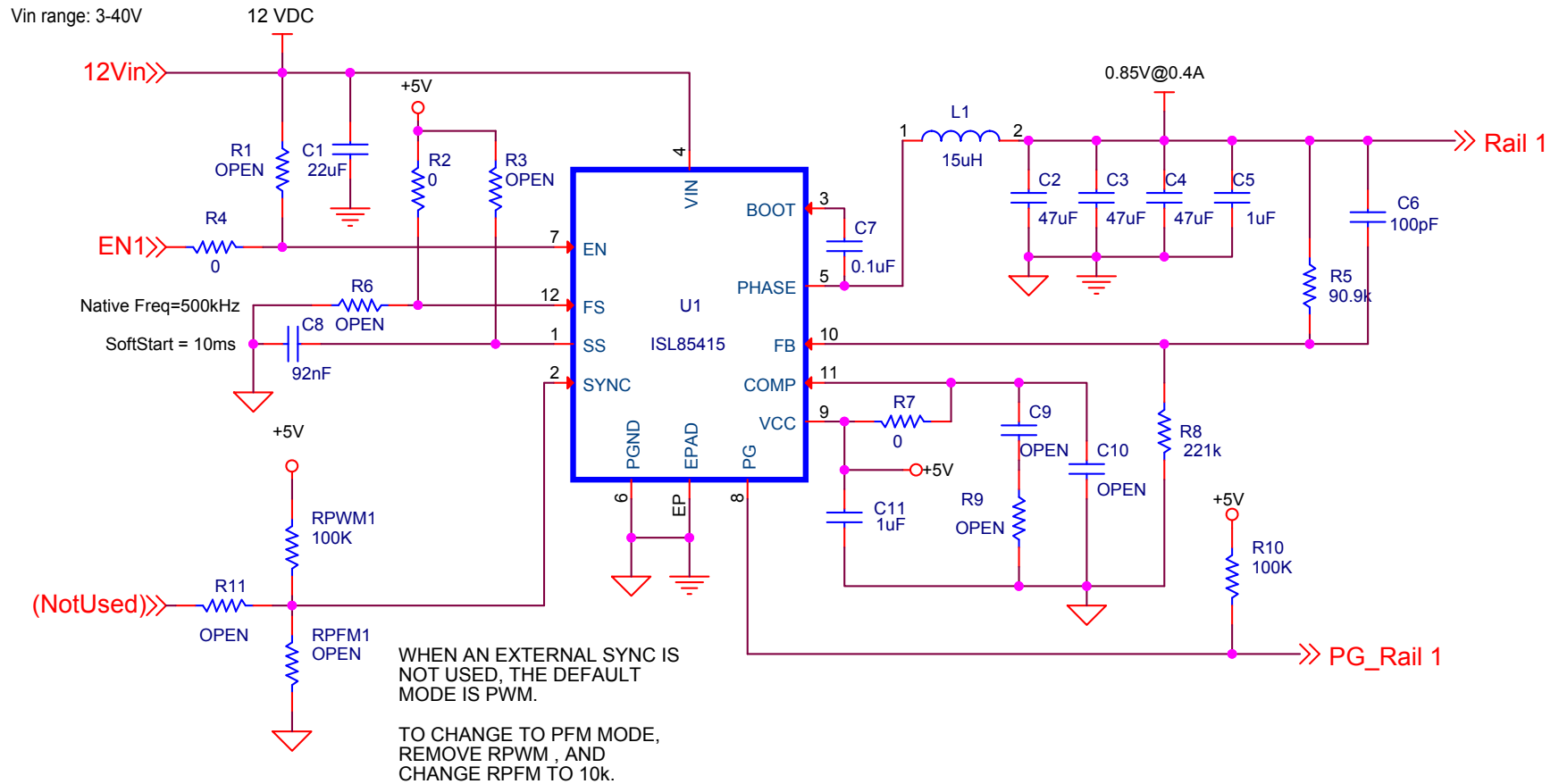

Title		
ISL85415-SINGLE-1		
Size A	Document Number	Rev
Date:	Thursday, March 09, 2017	Sheet 2 of 14

ISL85418 SINGLE OUTPUT (800mA)

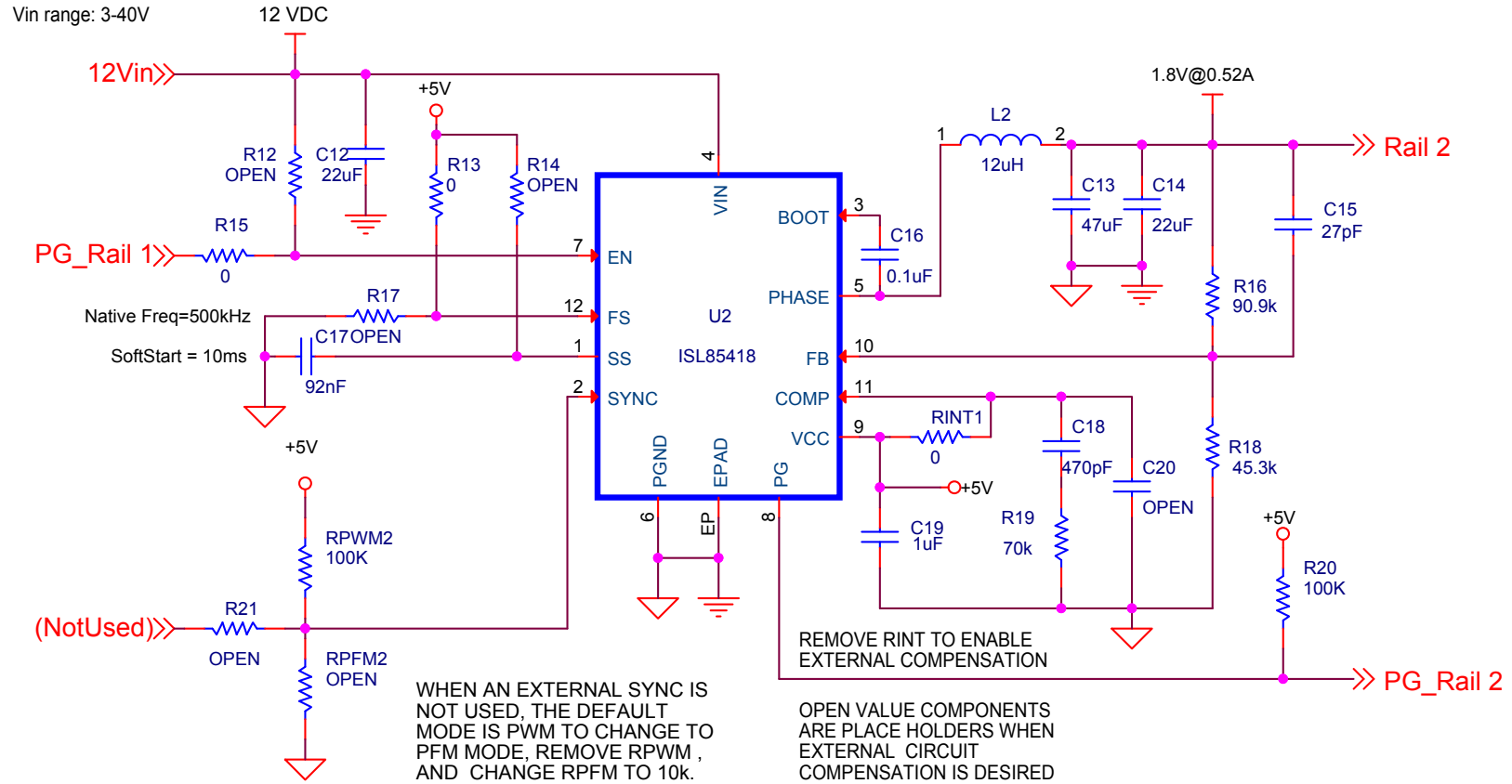

Title		
ISL85418-SINGLE-1		
Size A	Document Number	Rev
Date:	Thursday, March 09, 2017	Sheet 3 of 14

ISL9021A Single Output (250mA)

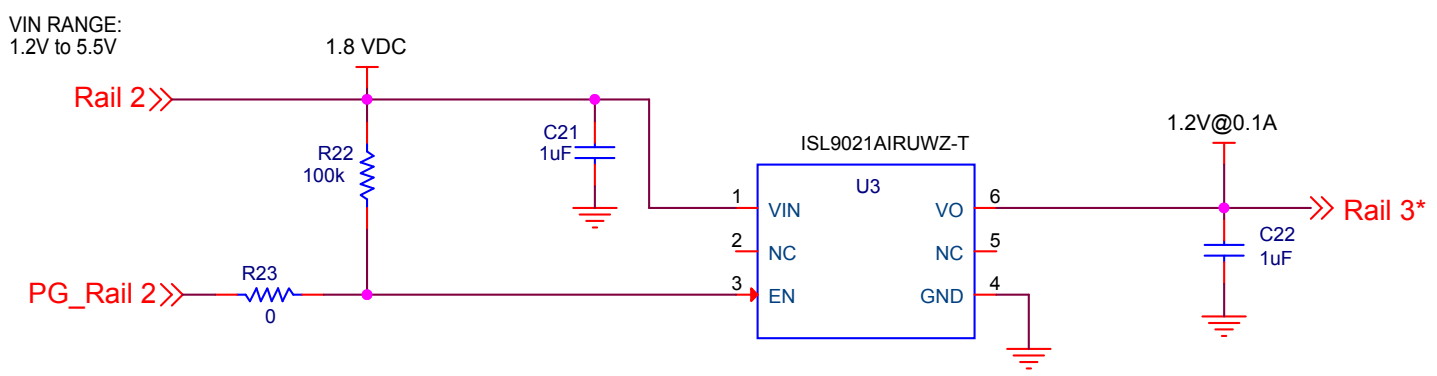

Title		
ISL9021A-SINGLE-1		
Size A	Document Number	Rev
Date:	2	Sheet 4 of 14

ISL85415 SINGLE OUTPUT (500mA)

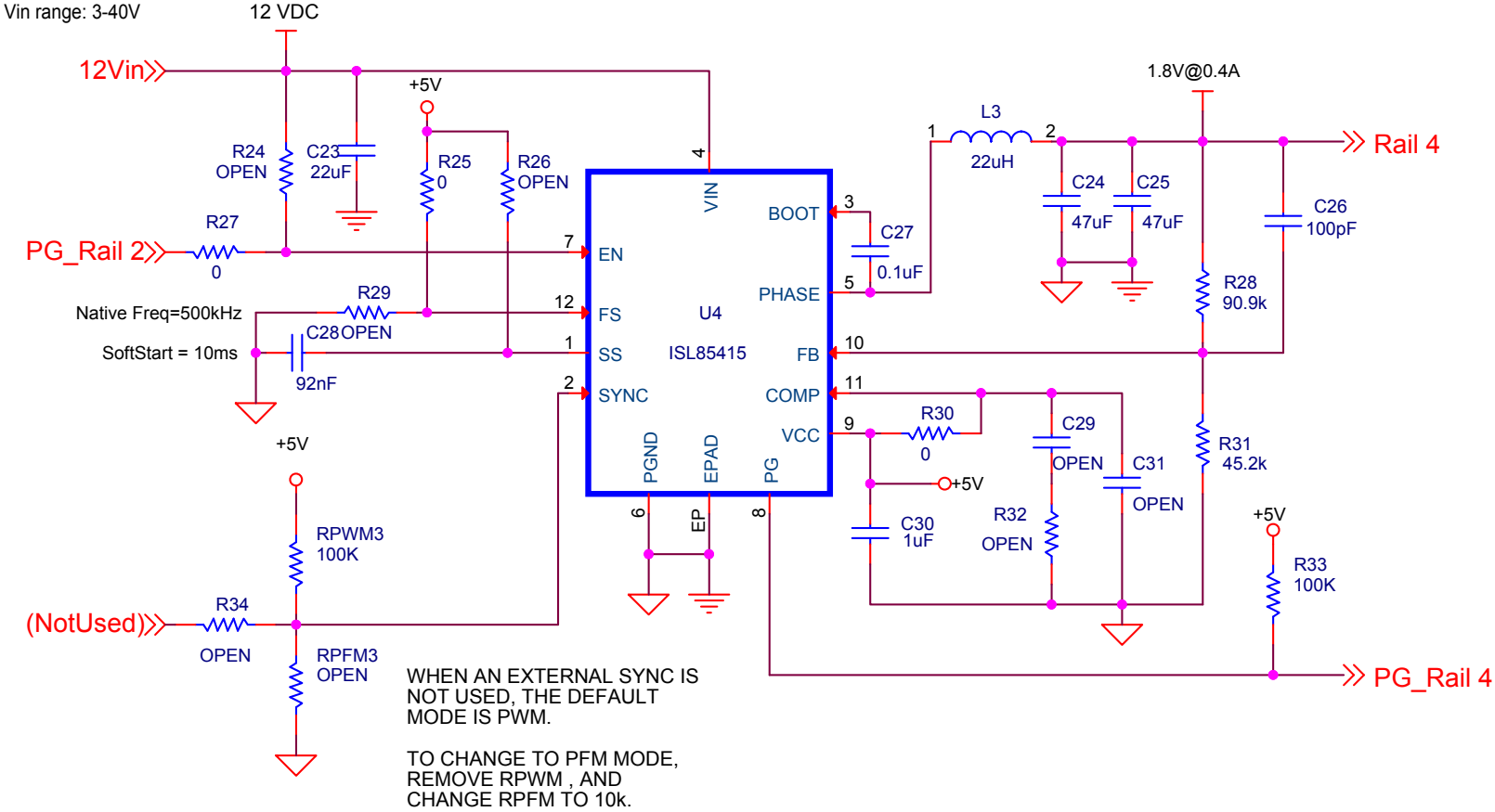

Title		
ISL85415-SINGLE-1		
Size A	Document Number	Rev
Date:	Thursday, March 09, 2017	Sheet 5 of 14

ISL85003 SINGLE OUTPUT (3A)

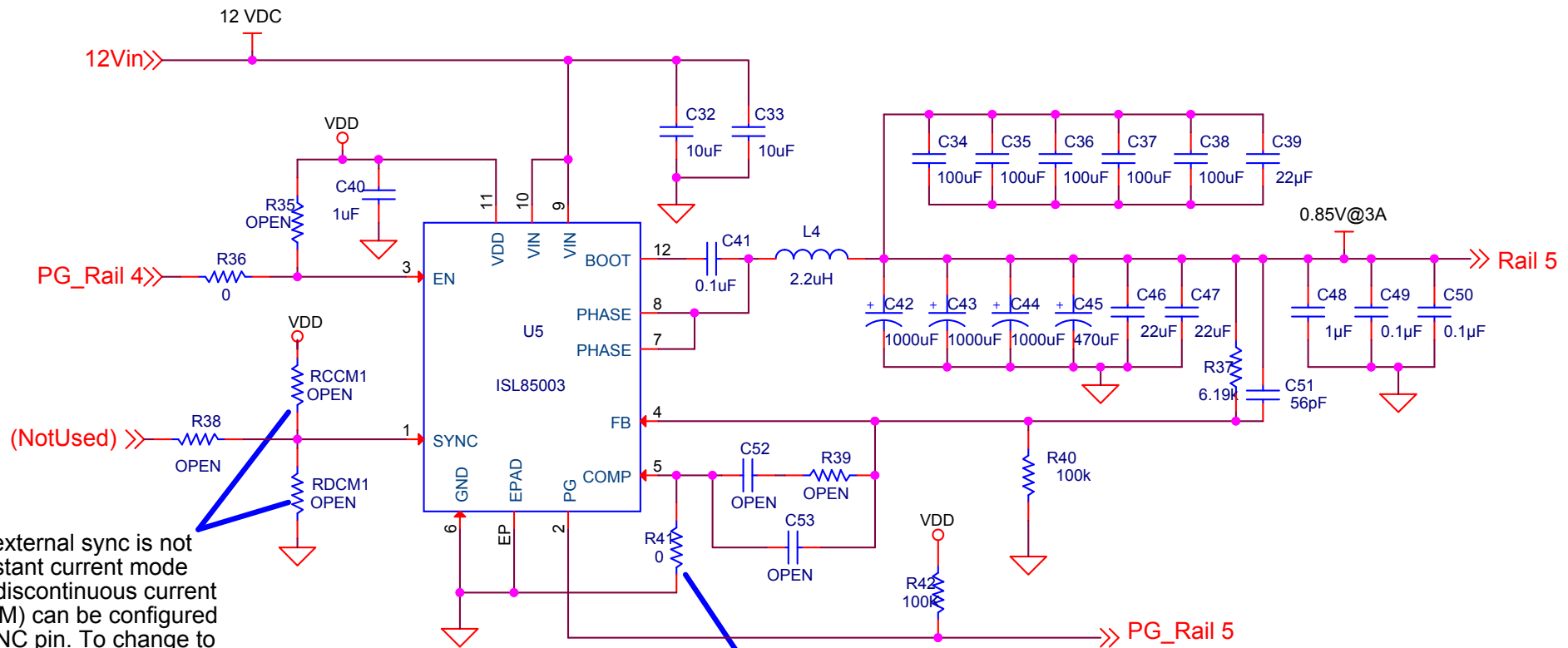

When an external sync is not used, constant current mode (CCM) or discontinuous current mode (DCM) can be configured on the SYNC pin. To change to DCM mode, remove RCCM, and change RDCM to 0 ohms.

If custom compensation is desired, remove the ground connection on the COMP pin to enable external compensation.

OPEN value components on the COMP pin are place holders if external compensation is used.

Programmable Soft Start is available in the ISL85003A (without synchronization)

Title		
ISL85003-SINGLE-1		
Size	Document Number	Rev
A	<Doc>	<Rev Co
Date:	Thursday, March 09, 2017	Sheet 6 of 14

ISL85412 SINGLE OUTPUT (150mA)

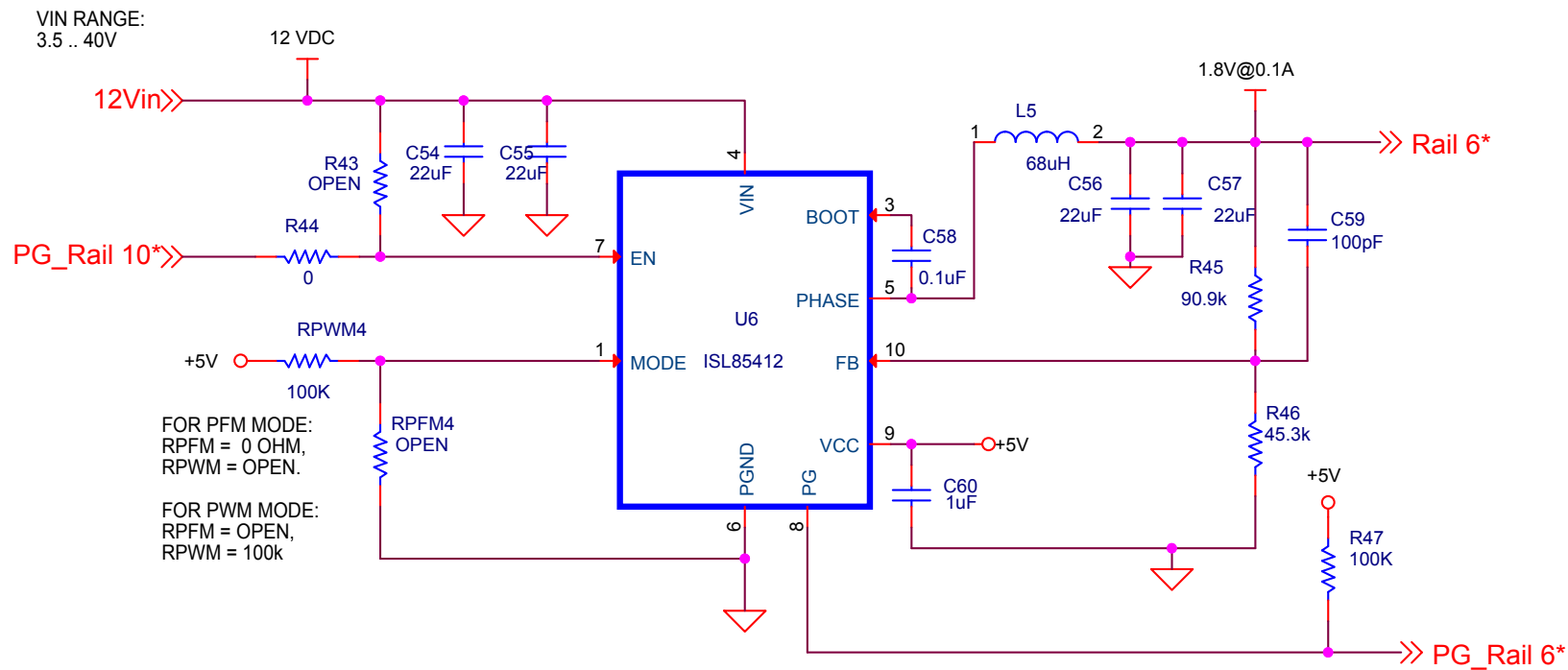

Title		
ISL85412-SINGLE-1		
Size	Document Number	Rev
A	<Doc>	
Date:	Thursday, March 09, 2017	Sheet 7 of 14

ISL85415 SINGLE OUTPUT (500mA)

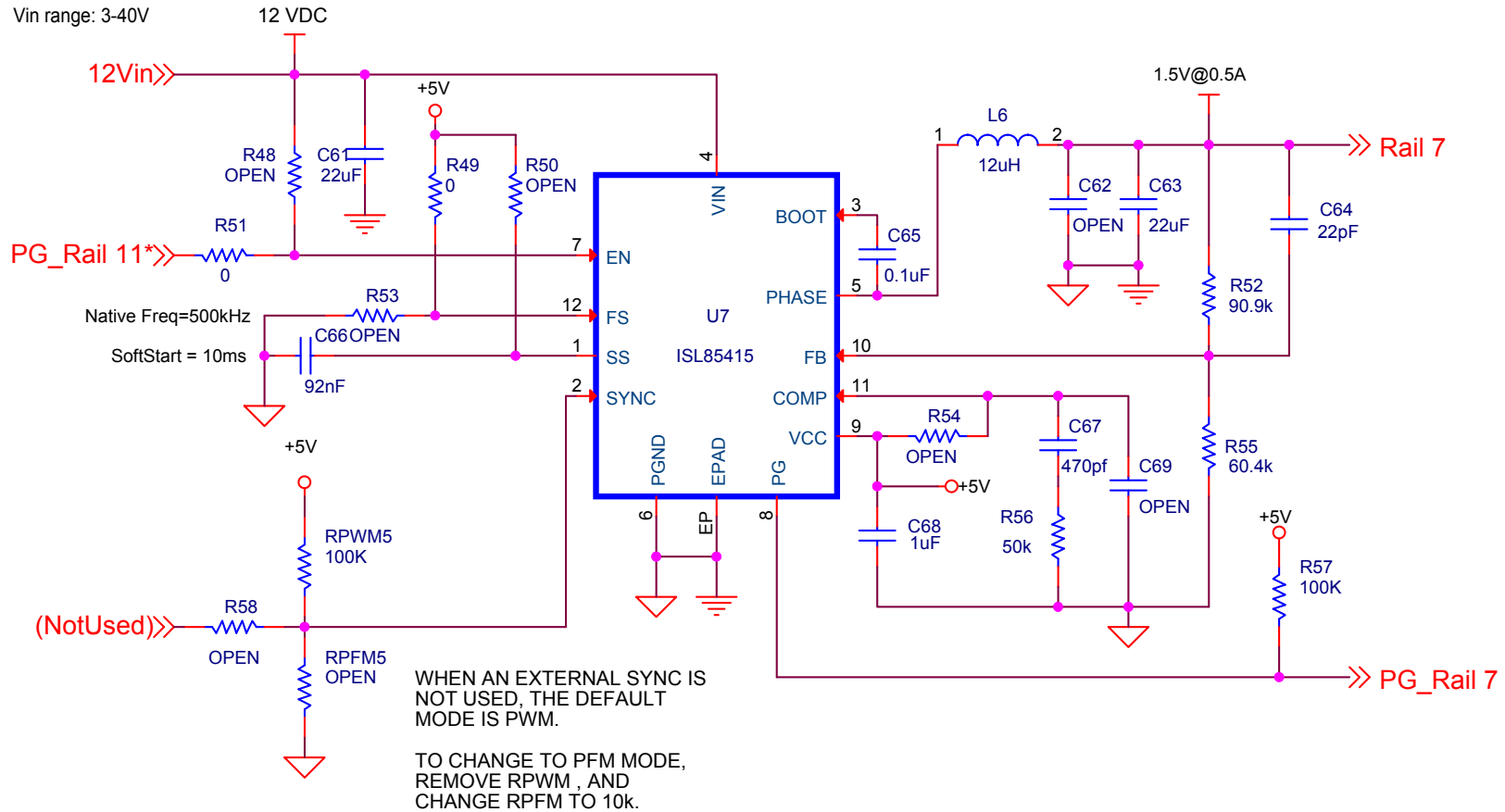

Title		
ISL85415-SINGLE-1		
Size A	Document Number	Rev
Date:	Thursday, March 09, 2017	Sheet 8 of 14

ZL9006M Digital Module (6A)

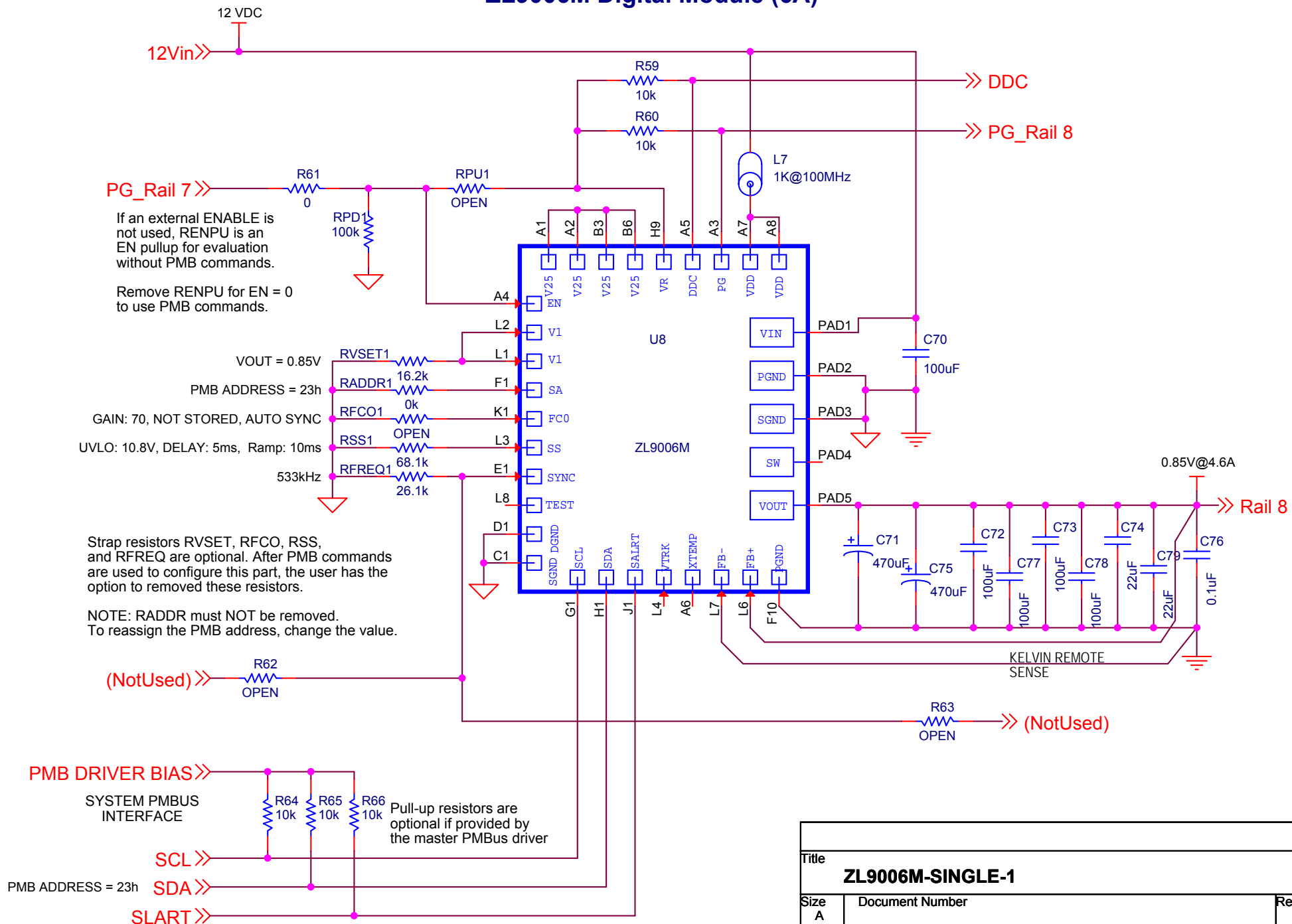

Title		
ZL9006M-SINGLE-1		
Size A	Document Number	Rev
Date:	Sheet 9	of 14

ISL85410 SINGLE OUTPUT (1A)

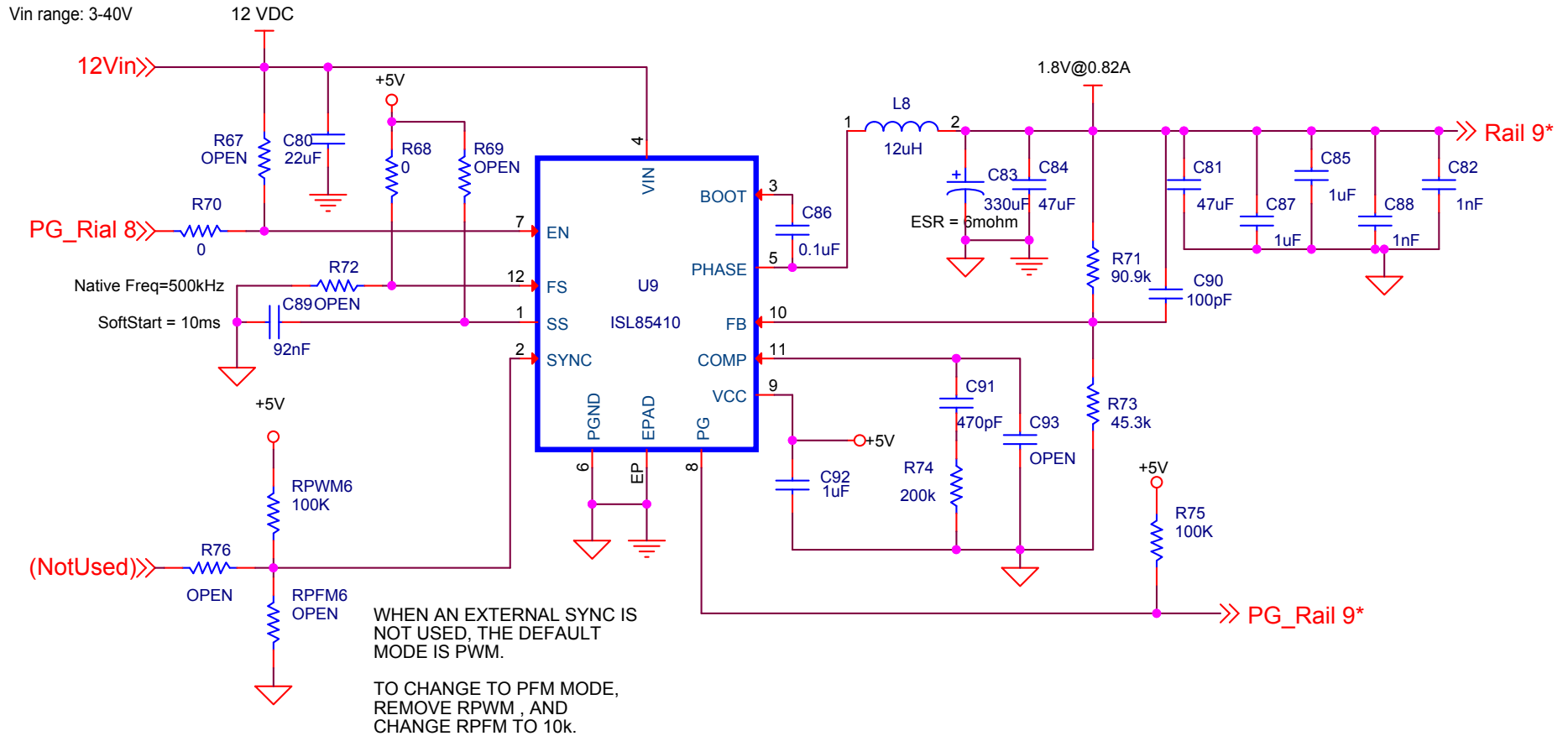

Title		
ISL85410-SINGLE-1		
Size A	Document Number	Rev
Date:	Thursday, March 09, 2017	Sheet 10 of 14

ISL85415 SINGLE OUTPUT (500mA)

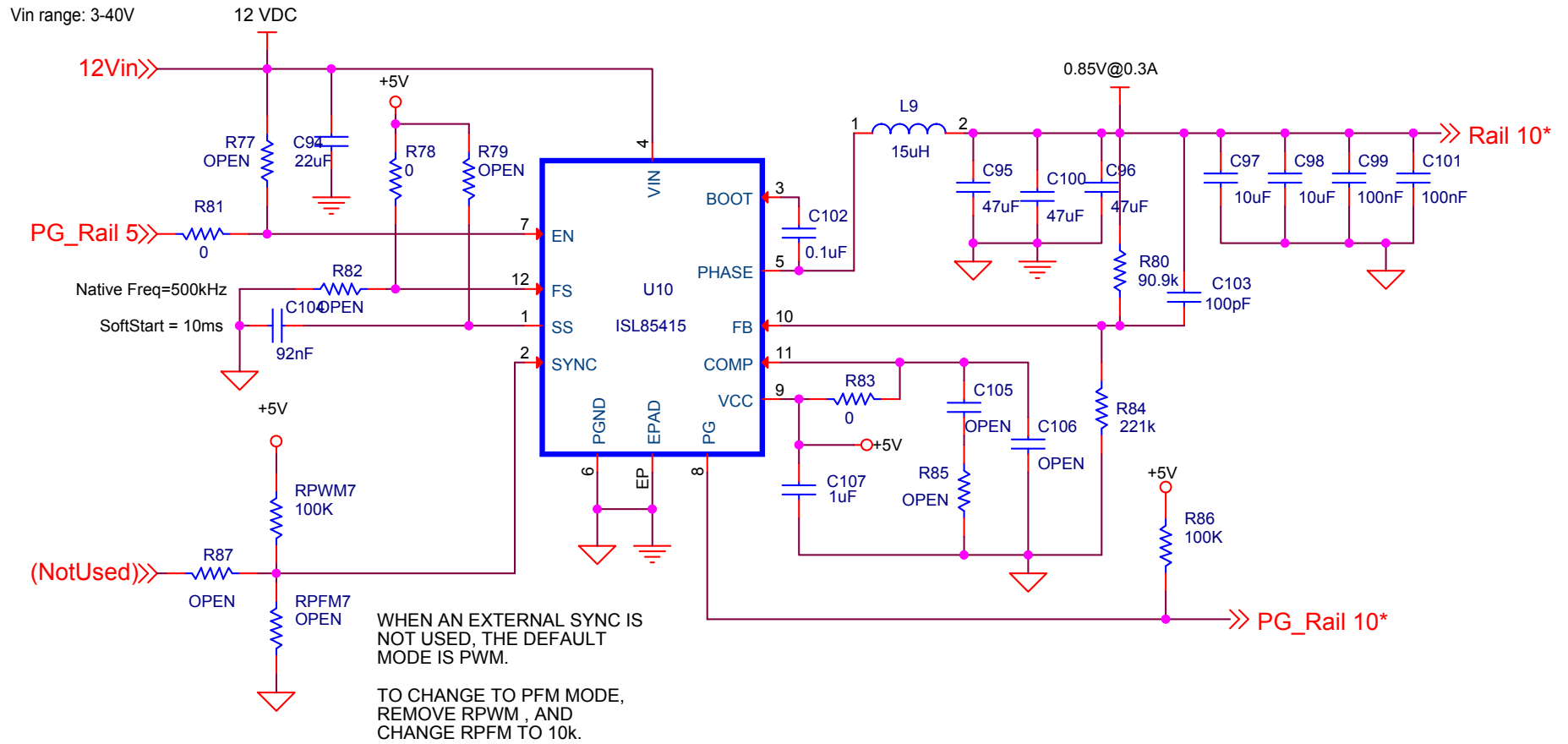

Title		
ISL85415-SINGLE-1		
Size A	Document Number	Rev
Date:	Thursday, March 09, 2017	Sheet 11 of 14

ISL85412 SINGLE OUTPUT (150mA)

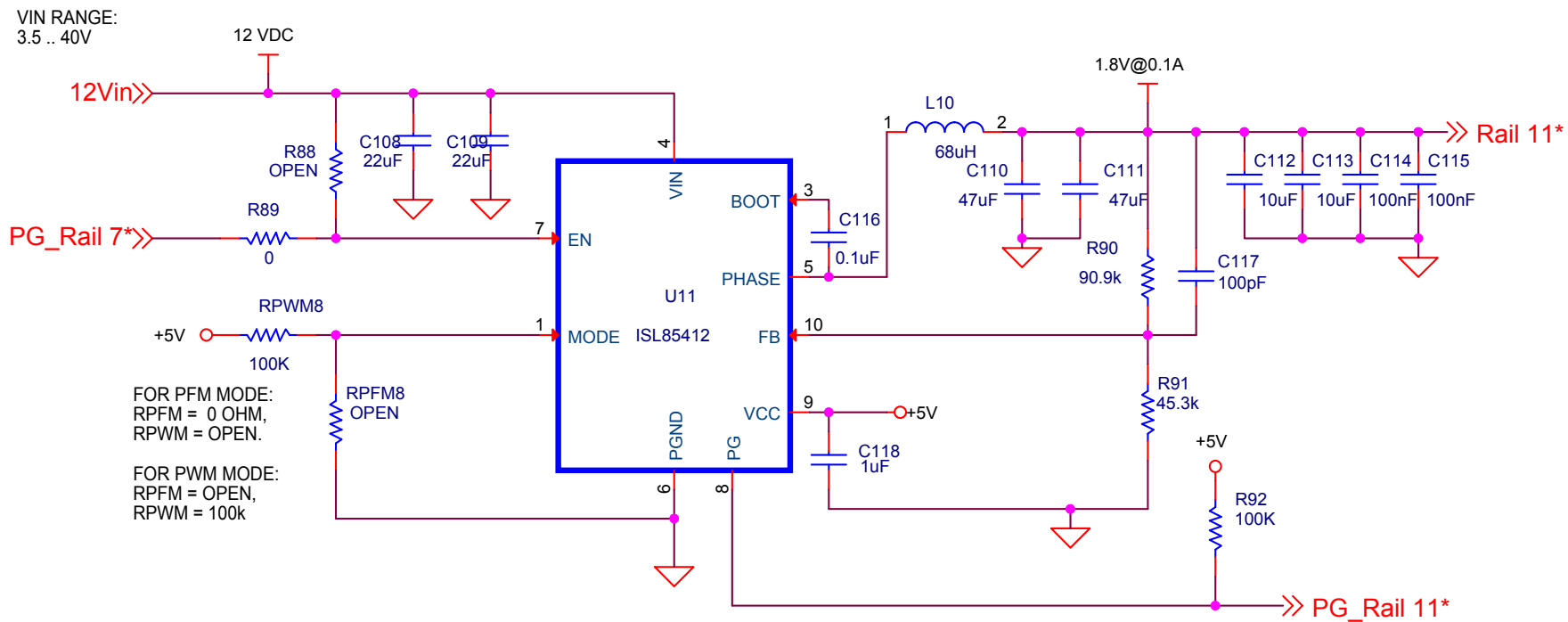

Title		
ISL85412-SINGLE-1		
Size	Document Number	Rev
A	<Doc>	
Date:	Thursday, March 09, 2017	Sheet 12 of 14
	2	1

ISL85415 SINGLE OUTPUT (500mA)

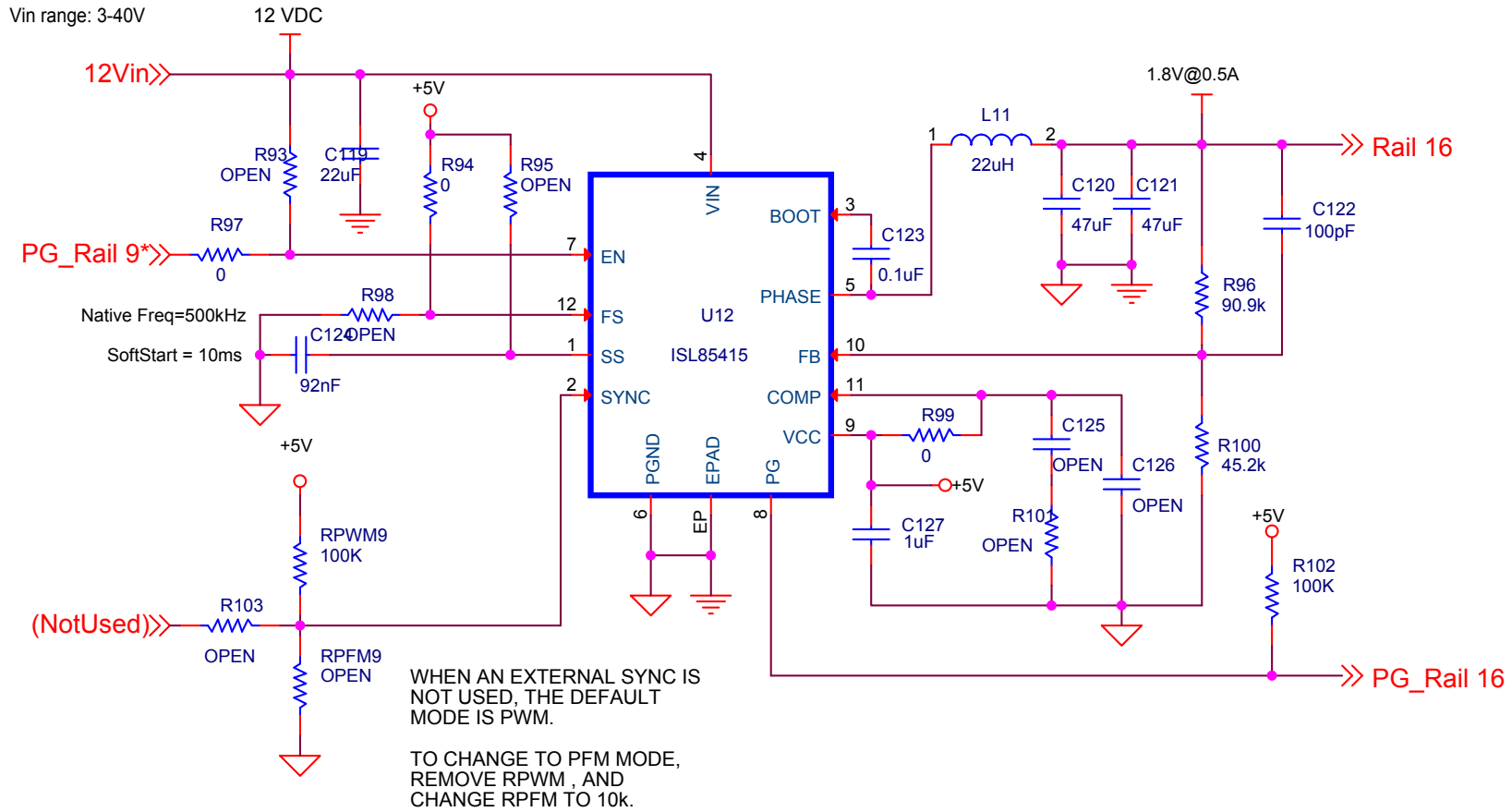

Title		
ISL85415-SINGLE-1		
Size A	Document Number	Rev
Date:	Thursday, March 09, 2017	Sheet 13 of 14

ISL85415 SINGLE OUTPUT (500mA)

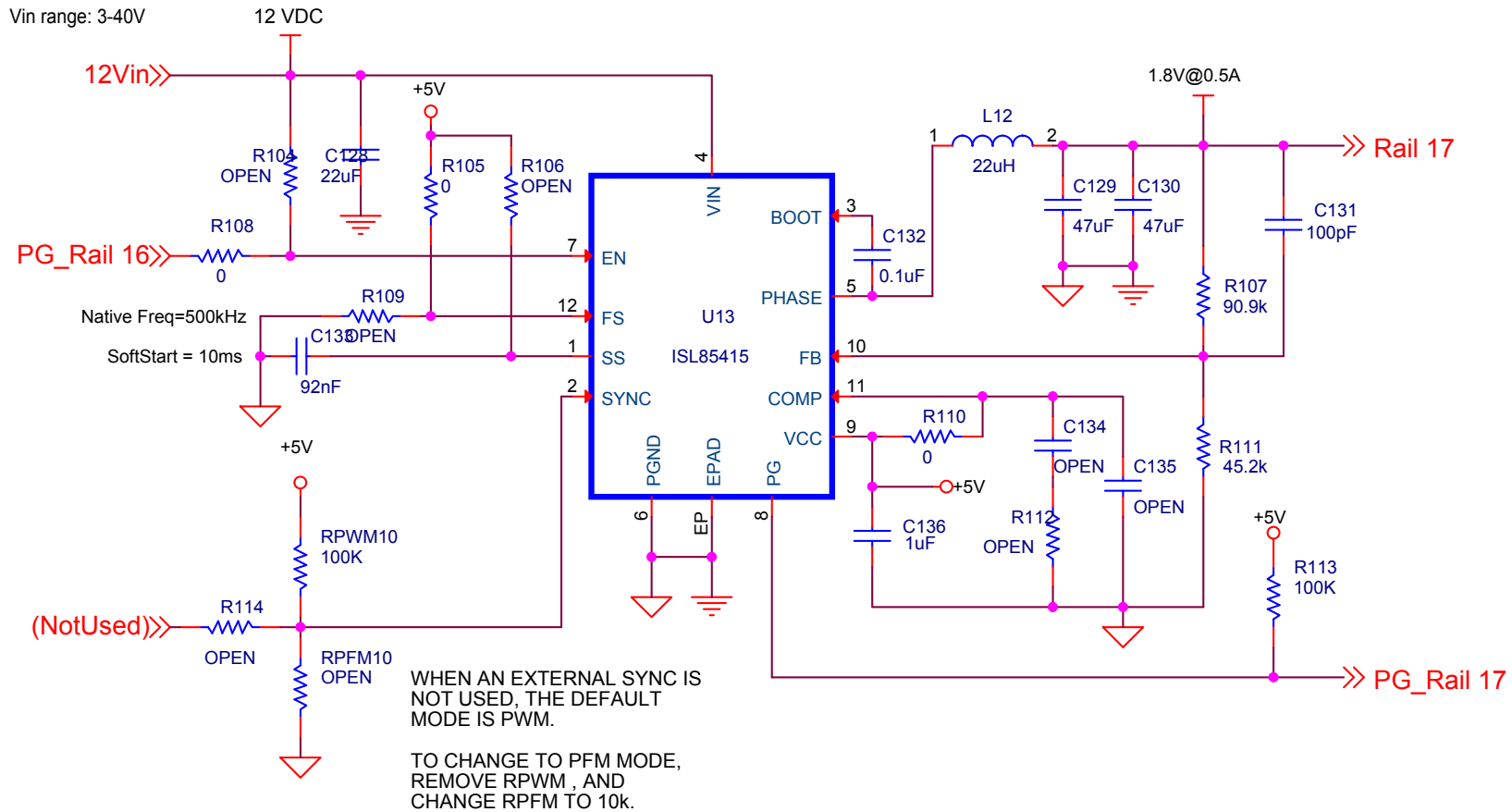

Title		
ISL85415-SINGLE-1		
Size A	Document Number	Rev
Date:	Thursday, March 09, 2017	Sheet 14 of 14