

# Application Note

## Low Power DC/DC Converter

### AN-CM-232

#### **Abstract**

*This application note presents a low cost and low power DC/DC push-pull converter based on the GreenPAK SLG46108 device.*

*This application note comes complete with design files which can be found in the References section.*

---

---

---



---

**Low Power DC/DC Converter**

## Contents

<b>Abstract</b> .....	<b>1</b>
<b>Contents</b> .....	<b>2</b>
<b>Figures</b> .....	<b>2</b>
<b>1 Terms and Definitions</b> .....	<b>3</b>
<b>2 References</b> .....	<b>3</b>
<b>3 Introduction</b> .....	<b>4</b>
<b>4 Operation Principle of Push-Pull Topology</b> .....	<b>4</b>
<b>5 Board Schematic and Layout</b> .....	<b>6</b>
<b>6 SLG46108 schematic</b> .....	<b>7</b>
6.1 Clock Configuration.....	8
6.2 PWM Configuration.....	8
6.3 Design Start-up .....	8
6.4 T <sub>1</sub> and T <sub>2</sub> Signals .....	8
6.5 PWM Output Signals.....	8
<b>7 Measurements</b> .....	<b>9</b>
<b>8 Conclusion</b> .....	<b>13</b>
<b>Revision History</b> .....	<b>14</b>

## Figures

Figure 1: Push-pull Topology Schematic.....	4
Figure 2: Push Pull Control Waveform .....	5
Figure 3: Circuit Model for MOSFET Gate Charge Influence. Source: [5] .....	5
Figure 4: MOSFET Turn On and Turn Off Time Graph. Source: modified from [6] .....	6
Figure 5: Push-Pull Circuit Schematic.....	6
Figure 6: Board Picture.....	7
Figure 7: SLG46108 GreenPAK Design.....	7
Figure 8: Steady State Control Signals .....	9
Figure 9: Dead Time Interval Measurement.....	10
Figure 10: Steady State Drain Voltage.....	10
Figure 11: Start-up PWM After the Rising of T <sub>1</sub> Signal .....	11
Figure 12: Start-up PWM After the Rising of T <sub>2</sub> Signal .....	11
Figure 13: Measurement of Input Current and Output Voltage with a Light Load.....	12
Figure 14: Measurement of Input Current and Output Voltage with Heavy Load .....	12
Figure 15: Measurement of Input Current During Shutdown .....	12

---

---

## Low Power DC/DC Converter

### 1 Terms and Definitions

ADC	Analogue-digital convertor
DC	Direct current
MCU	Micro controller unit
MOSFET	Metal-oxide-semiconductor field-effect transistor
PWM	Pulse width modulation

### 2 References

For related documents and software, please visit:

[GreenPAK™ Programmable Mixed-Signal Products | Renesas](#)

Download our free [GreenPAK™ Designer](#) software [1] to open the .gp files [2] and view the proposed circuit design. Use the [GreenPAK](#) development tools [3] to freeze the design into your own customized IC in a matter of minutes. Renesas Electronics provides a complete library of application notes [4] featuring design examples as well as explanations of features and blocks within the IC.

- [1] [GreenPAK Designer Software](#), Software Download and User Guide, Renesas Electronics
- [2] [AN-CM-232 Low Power DC-to-DC Converter.gp](#), [GreenPAK Design File](#), Renesas Electronics
- [3] [GreenPAK Development Tools](#), [GreenPAK Development Tools Webpage](#), Renesas Electronics
- [4] [GreenPAK Application Notes](#), [GreenPAK Application Notes Webpage](#), Renesas Electronics
- [5] Power MOSFET Basics: Understanding the Turn ON Process, AN-850, Vishay
- [6] Power MOSFET Basics: Understanding Gate Charge and Using it to Assess Switching Performance, AN-608A, Vishay

## Low Power DC/DC Converter

### 3 Introduction

Galvanically isolated interfaces are a common requirement within industrial devices for safety reasons. In this type of application, a digital isolator is used to galvanically isolate an MCU from a communication transceiver or an ADC.

Digital isolators work at two power domains, using an isolated DC power supply in one domain. The low DC voltage for isolated power domain could be achieved with a small and simple push-pull converter. The push-pull converter is a transformer-isolated topology using two transistors switching in complementary mode.

This application note will present a low cost and low power DC/DC push-pull converter based on the GreenPAK SLG46108 device. The following sections will show how to:

- Generate a complementary PWM with dead time using the programmable delay block.
- Generate a start-up sequence using a pipe-delay block.
- Obtain multiple clock frequencies via an internal oscillator.

### 4 Operation Principle of Push-Pull Topology

A push-pull converter schematic topology is shown in Figure 1. This converter uses a transformer with center-tap in the primary and secondary windings. Two transistors ( $Q_1$  and  $Q_2$ ) work to switch the DC input voltage  $V_{IN}$  in alternate half-cycles.

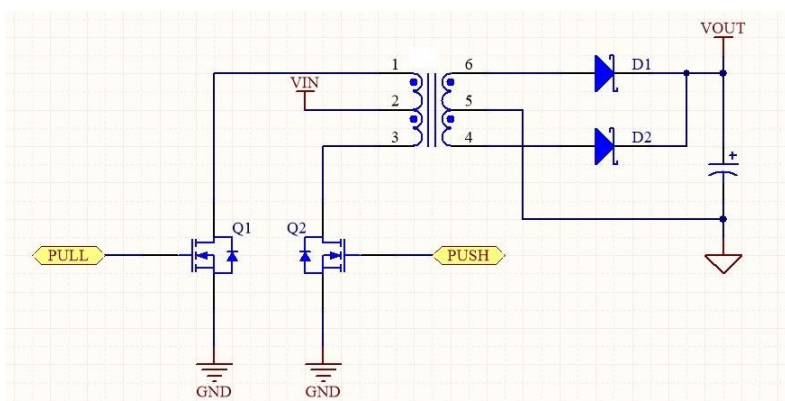

**Figure 1: Push-pull Topology Schematic**

On the primary side, when the PUSH command signal (Figure 1) is HI,  $Q_2$  transistor is turned on and transformer current flows from  $V_{IN}$  to  $Q_2$  transistor. Simultaneously in the secondary winding a transformer current flows from diode  $D_1$  to the output capacitor, returning through the center-tap.

The PUSH command is HI during one half cycle. The PULL command is high during the other half cycle. When the PULL command is high,  $Q_1$  transistor is turned on and the current flows from  $V_{IN}$  to  $Q_1$  in the primary, and from  $D_2$  to the output capacitor in the secondary.

The current flows in the same direction in the output capacitor during both current cycles, keeping a positive output voltage  $V_{OUT}$ . The converter output voltage could be given by equation (1)

$$V_{OUT} = 2 * D * V_P * n - V_{DIODE} \quad (1)$$

Where  $V_{OUT}$  is the output voltage,  $D$  is the duty cycle,  $V_P$  is the voltage in the transformer primary winding,  $n$  is the transformer turn-ratio and  $V_{DIODE}$  is the voltage drop in outputs at diodes ( $D_1$  and  $D_2$ ).  $V_P$  is given by equation (2):

$$V_P = V_{IN} - V_{DS} \quad (2)$$

## Low Power DC/DC Converter

where  $V_{DS}$  is the voltage drop from the internal resistance of transistors  $Q_1$  and  $Q_2$ .

An issue with this topology is the variation on output voltage with load current change. To ensure a stable output voltage a linear regulator should be added to the output, and the converter output voltage must be higher than the minimum specified for the regulator. The PUSH and PULL command signals are shown in Figure 2. Command signals are complementary and should have the same duty cycle to avoid transformer core saturation.

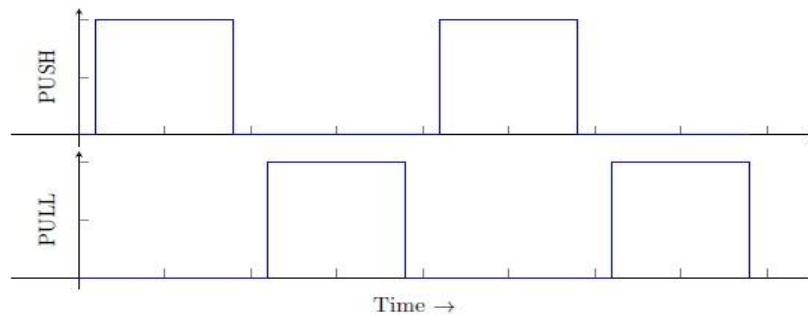

**Figure 2: Push Pull Control Waveform**

An important aspect for push pull converters is the need for a short time interval where both commands are low, as can be seen in Figure 2. This time interval is required to avoid the short circuit of both primary ends of the transformer.

The transistors  $Q_1$  and  $Q_2$  require a small amount of time to effectively turn-on and turn-off. The MOSFET turn-on and turn-off involves a process of charging and discharging a MOSFET gate. A common approach is to model MOSFET gate charge influence as capacitors between MOSFET source and drain. This is shown in Figure 3.

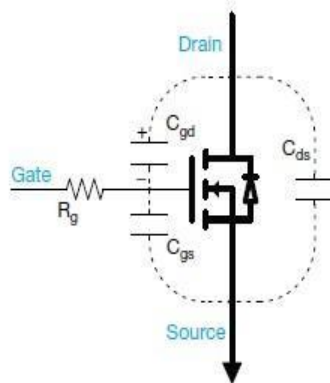

**Figure 3: Circuit Model for MOSFET Gate Charge Influence. Source: [5]**

In datasheets the turn-on and turn-off transitions are presented as shown in Figure 4. However, the switching times are highly affected by circuit conditions, such as gate drive resistance, drain-source voltage, etc.

Low Power DC/DC Converter

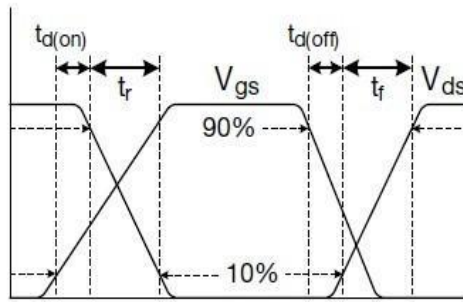

Figure 4: MOSFET Turn On and Turn Off Time Graph. Source: modified from [6]

The time interval is short and should be generated by the driver, which generates a dead time interval between the switches command. The push pull duty cycle is lower than 50 % because of dead time interval. That usually reduces duty-cycle by 3-5 %. This reduction in duty cycle lowers the output voltage and increases dissipation losses.

5 Board Schematic and Layout

Figure 5 depicts the board schematic of a low power converter module using the SLG46108. The module has an input DC voltage of 5 Volts (J1 connector) and an isolated output with more than 5 Volts. Output voltage (J2 connector) is higher than 5 V to enable the operation of a linear regulator.

In this circuit the SLG46108 generates the control signals PWMPOS and PWMNEG to switch the two transistors Q1 and Q2. The PWM signal is active when SHUTDOWN input is low or is left open. When SHUTDOWN is high the PWM signal is inactive and both transistors are turned off.

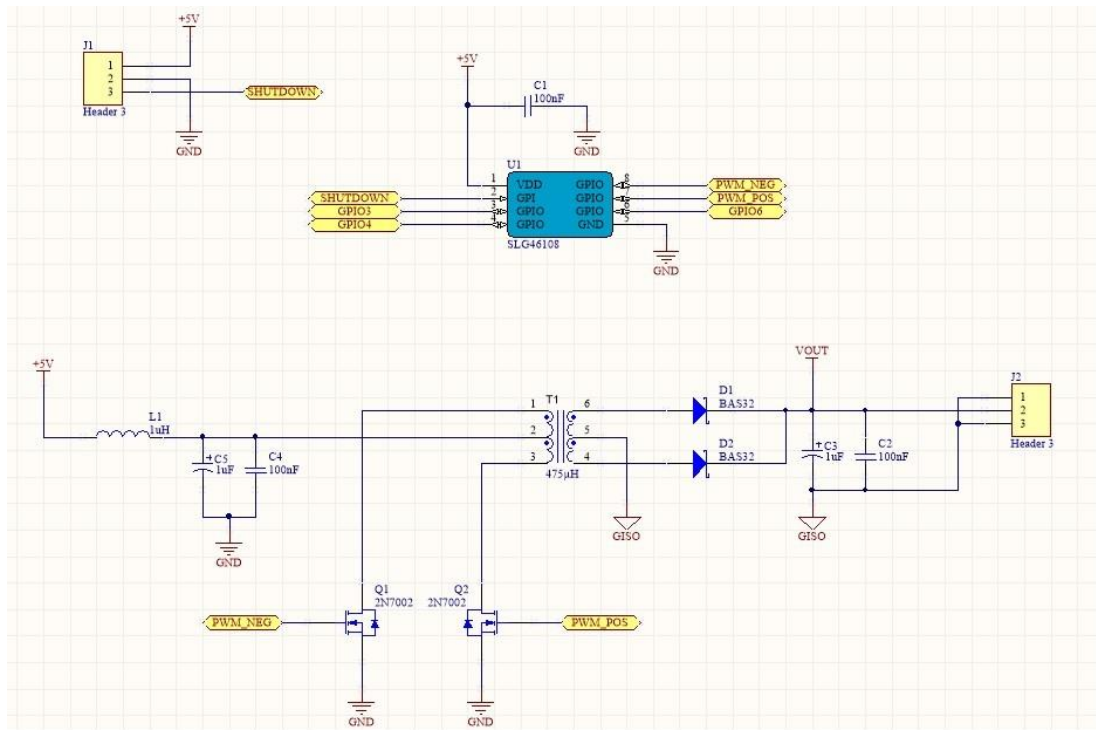

Figure 5: Push-Pull Circuit Schematic

Low Power DC/DC Converter

The switching dead time interval is defined to generate a duty cycle of 45 %, considering a switching frequency of 250 kHz. This approach enables the use of different transistors with the developed controller. The drawback is the reduction in the output voltage and the reduction in efficiency.

The selected transformer is the Würth Electronic part-number 760390014 that has a turns-ratio of 1:1.3. The output diodes are the part-number BAS32, from Nexperia. For this project we have considered the maximum diode drop-out voltage as 0.7 V. Both transistors are the well-known 2N7002 NMOS.

For this circuit we calculate the expected minimum output voltage, when the diode drop-out voltage is maximum, using equation 1. Then:

$$V_{OUT} = 2 * 0.45 * 5 * 1.3 - 0.7 = 5.85 - 0.7 = 5.15 \text{ V}$$

The drop-out voltage in transistors is neglected for simplicity, as the load current is low and the MOSFET equivalent resistance is low too. The output voltage must be higher than the calculated minimum voltage, especially at light loads.

Figure 6 shows a picture of the mounted module board:



Figure 6: Board Picture

6 SLG46108 schematic

The project design developed in GreenPAK Designer is shown in Figure 7.

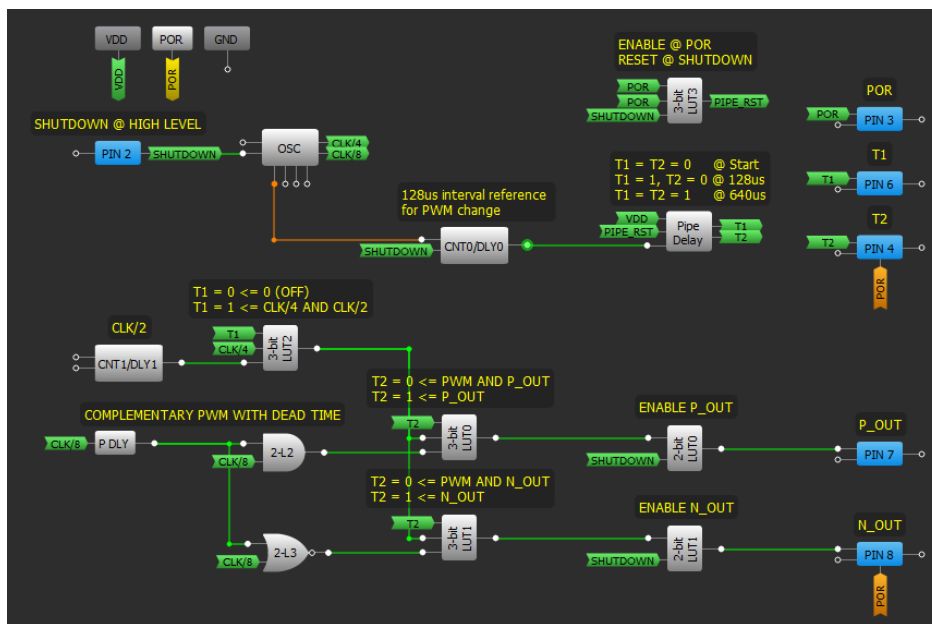

Figure 7: SLG46108 GreenPAK Design

---

---

## Low Power DC/DC Converter

### 6.1 Clock Configuration

The implemented solution uses a 250 kHz clock signal (CLK/8) from the OSC block as the base PWM signal. The OSC block is configured to a main clock frequency of 2 MHz (CLK) and two of its outputs are used: the clock divided by four (CLK/4) and by eight (CLK/8). The main oscillator clock is sourced to block CNT1/DLY1 to generate a clock divided by two (CLK/2).

### 6.2 PWM Configuration

To generate the complementary PWM signal with a dead time between the transitions, we used the structure of block P DLY, 2-L2 and 2-L3. Base PWM signal of 250 kHz frequency is delayed in Programmable Delay block by nearly 222ns (2 cells delay at 5 V). These two signals are inputs to blocks 2-L2 and 2-L3. Block 2-L2 is an AND logic port and the output will be high only when the CLK/8 and his delayed version are high. Block 2-L3 is an NOR logic port and the output will be high only when CLK/8 and his delayed version are both logic low.

This structure generates the complementary PWM signal with the same duty cycle in both outputs and a dead time interval between transitions. Before output signals OUT P and OUT N can drive output pins, the signals should pass through blocks 3bit-LUT0 and 3bit-LUT1.

### 6.3 Design Start-up

Blocks 3bit-LUT0 and 3bit-LUT1 are part of the design start-up logic. Start-up sequence logic is required in the converter to avoid high inrush current during initialization. The start-up process has two phases that are controlled by the signals  $T_1$  and  $T_2$ , generated via a Pipe Delay block. The Pipe Delay block starts counting pulses of the CNT0/DLY0 block after block reset. The CNT0/DLY0 block generates a pulse every 128  $\mu$ s. This keeps the  $T_1$  and  $T_2$  signals LO during the first 128  $\mu$ s of operation.

### 6.4 $T_1$ and $T_2$ Signals

$T_1$  signal is an input for 3bit-LUT2 block. The LUT2 block sends a PWM signal with a small duty cycle generated by the AND operation of signals CLK/4 and CLK/2 when  $T_1$  is high and a continuous LO signal when  $T_1$  is low.

The  $T_2$  signal is an input for 3bit-LUT0 and 3bit-LUT1 blocks. The  $T_2$  signal is used in these blocks to select the duty cycle of the output PWM drive signals. When  $T_2$  is LO the signals OUT P and OUT N are ANDed with the signal PWM that comes from block 3bit-LUT2. In this situation the output signals P, from 3-bit LUT0, and N, from 3-bit LUT1, have the same duty cycle of PWM signal. When  $T_2$  is HI the output signals P and N are the same as OUT P and OUT N. If  $T_2$  and  $T_1$  signal are both low, PWM signal is always low and the outputs P and N will be always low too.

This group of blocks enables the control of PWM output signals using  $T_1$  and  $T_2$ . After the initial 128  $\mu$ s LO signal both PWM outputs will have a small duty cycle, until  $T_2$  signal rises to high level. A  $T_2$  signal rise to high logic level will happen after 640  $\mu$ s of the start operation, or after 512  $\mu$ s after the rising edge of  $T_1$  signal.

### 6.5 PWM Output Signals

The PWM output signals P and N drive the output pins. They pass through two enable blocks, the 2bit-LUT0 and 2bit-LUT1. These blocks enable output signals when SHUTDOWN signal is low. When SHUTDOWN signal is high the output will be always low. SHUTDOWN signal is an input signal from PIN2. This pin is configured with a pull-down of 1 M $\Omega$  and is used to put all the circuit into a low power mode. When SHUTDOWN is high the oscillator is put in low power mode and Pipe Delay block is reset. This procedure guarantees the application of start-up logic after SHUTDOWN signal falling, turning on the circuit again. The block 3bit-LUT3 is used to enable Pipe Delay counting only after the rising of POR signal and when SHUTDOWN signal is low.



## Low Power DC/DC Converter

PIN 8 and PIN 7 are outputs that receive the PWM signals from 2-bit LUT1 and 2-bit-LUT0 respectively, driving the two transistors  $Q_1$  and  $Q_2$ . PINs 6, 4 and 3 are configured as outputs and receive signals  $T_1$ ,  $T_2$  and POR respectively. These signals are used for the measurement of startup signals only.

## 7 Measurements

The board module was tested for an input voltage of 5V and the control signals were measured with an oscilloscope.

Figure 8 shows the complementary output PWM when the circuit is in steady state operation. The measured PWM frequency is 252.5 kHz, near to the expected 250 kHz frequency.

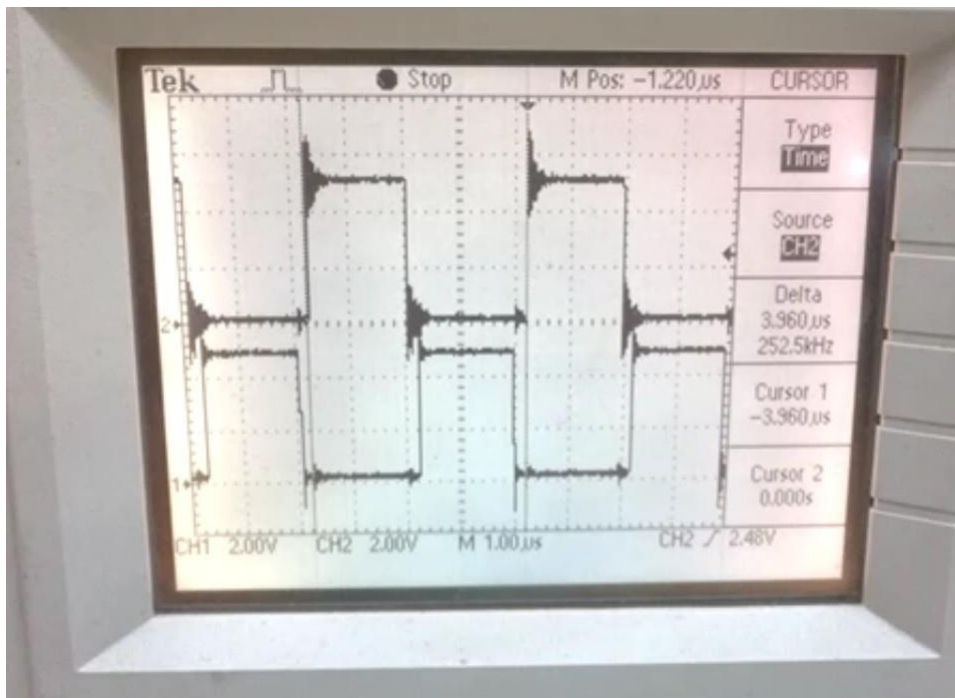

**Figure 8: Steady State Control Signals**

Figure 9 shows the measurement of the circuit dead time interval. The difference between cursor 1 and 2 is about 200 ns, nearly the expected value of 222 ns.

The voltage on the drain of  $Q_1$  and  $Q_2$  MOSFET is shown in Figure 10. The voltage is low when the MOSFET is conducting. The voltage in the drain MOSFET is double of  $V_{IN}$  when it is off, because of the voltage reflection on the primary.

During start-up the control generates a PWM that has a reduced duty cycle. It can be seen in Figure 11. Figure 12 shows the duty cycle change after the rising edge of  $T_2$  signal. The transistor On time is measured as 320 ns during the first PWM cycle.

Low Power DC/DC Converter

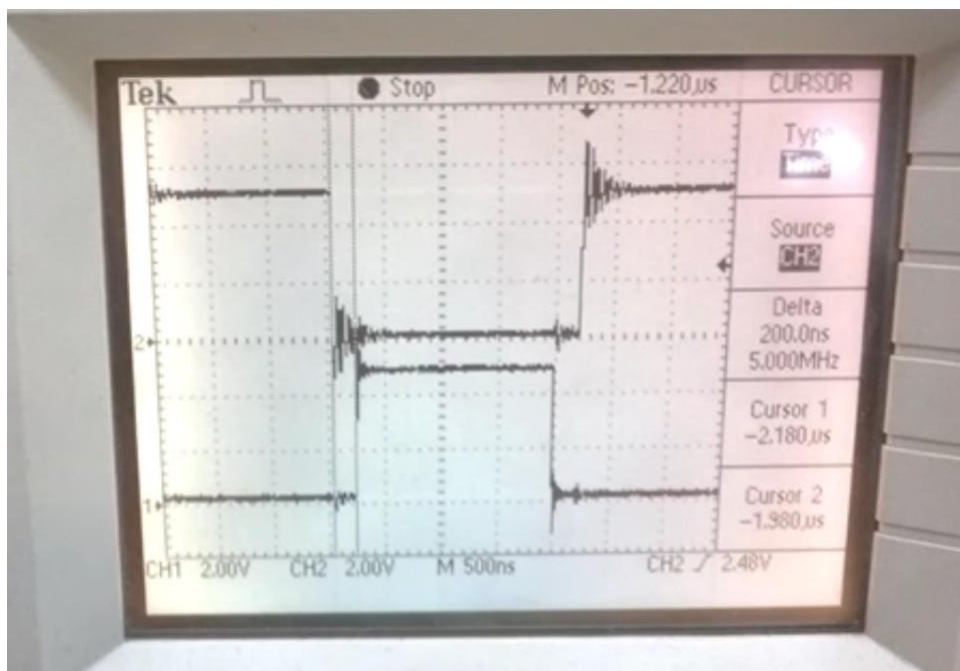

Figure 9: Dead Time Interval Measurement

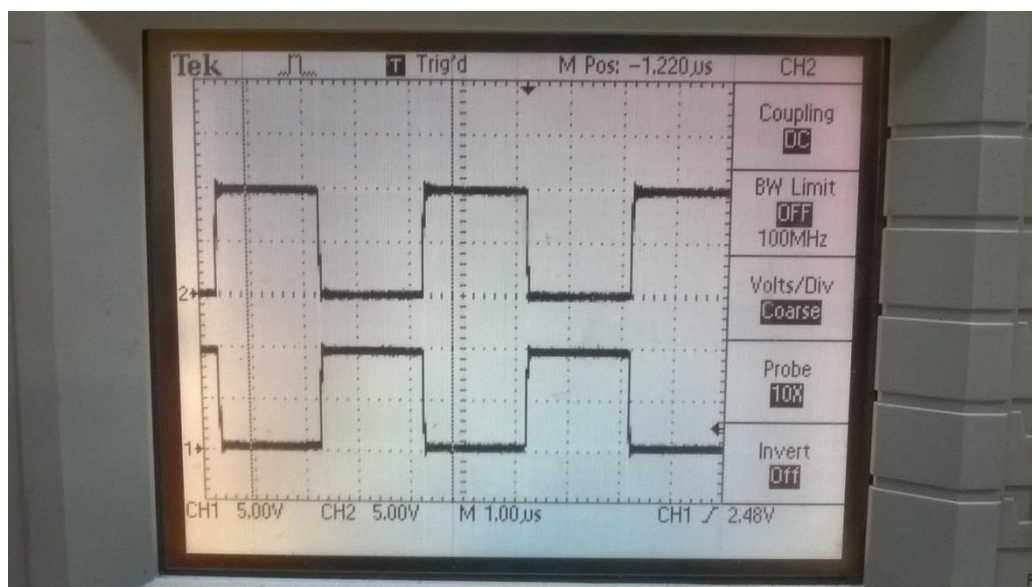

Figure 10: Steady State Drain Voltage

Low Power DC/DC Converter

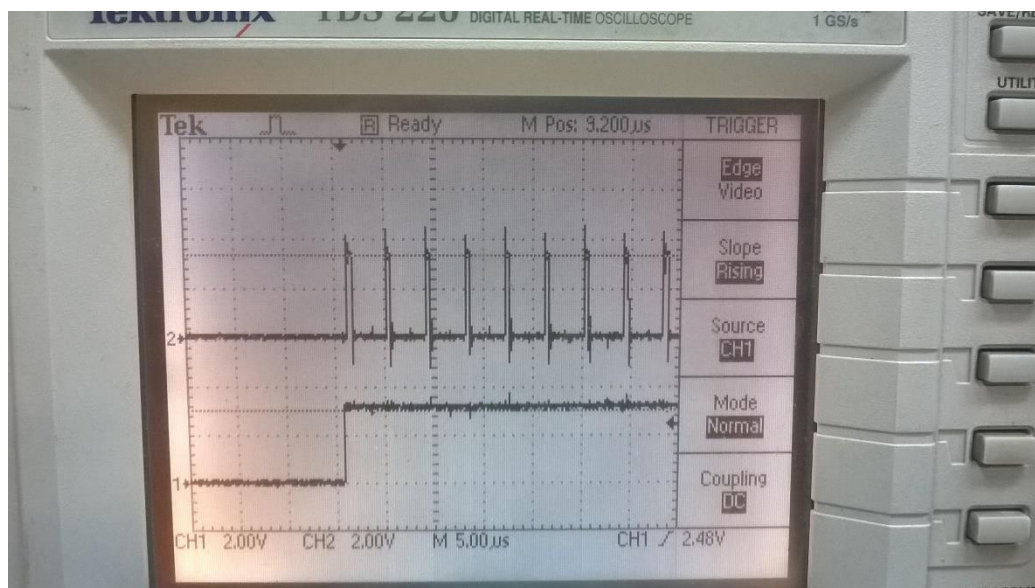

Figure 11: Start-up PWM After the Rising of T<sub>1</sub> Signal

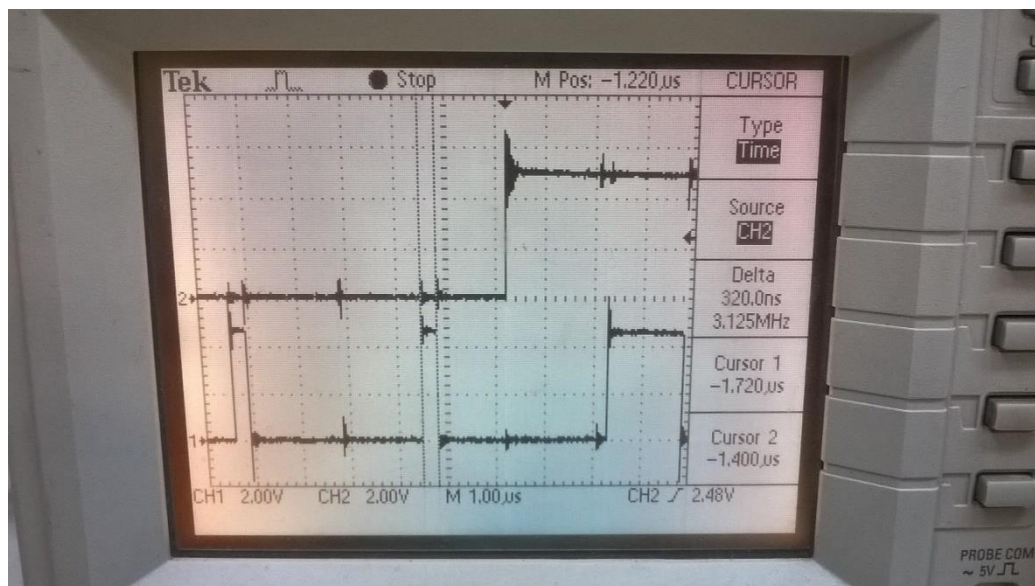

Figure 12: Start-up PWM After the Rising of T<sub>2</sub> Signal

Converter output voltage and input current were measured with a 10 KΩ resistor in parallel with a 1 KΩ resistor. The measured voltage is 5.89 Volts and input current was 15.7 mA, as shown in Figure 13.

---

 Low Power DC/DC Converter
 

---



**Figure 13: Measurement of Input Current and Output Voltage with a Light Load**

The output voltage and input current were measured with a heavy load of 120  $\Omega$  resistor too. The measured voltage is 5.18 Volts (almost 44 mA output current) and input current was 64.4 mA, as shown in Figure 14.



**Figure 14: Measurement of Input Current and Output Voltage with Heavy Load**

The circuit input current during shutdown was measured too, achieving 5.7  $\mu$ A of current, as can be seen in Figure 15. The most significant part of shutdown current is from the presence of 1 M $\Omega$  pull-down resistor.

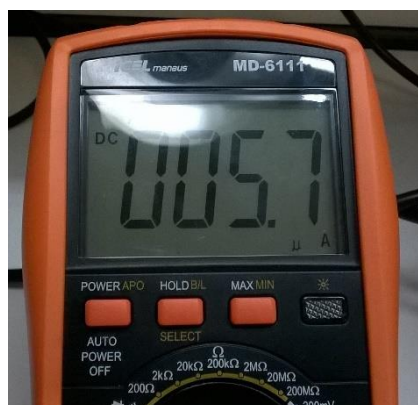

**Figure 15: Measurement of Input Current During Shutdown**

## 8 Conclusion

This application note presented how to implement a low power and small-factor DC/DC push-pull converter with a **GreenPAK** IC. The main advantage of **GreenPAK** over other solutions is the presence of a programmable delay block. This block makes the design of dead time insertion logic really simple. It is interesting to see how it was possible to add a personalized start-up sequence using pipe delay block and the addition of a shutdown mode control. Although this circuit was designed to operate on supply voltage of 5 Volts, it can also work at a supply voltage of 3 Volts. The only limitation on the supply voltage is the threshold voltage of MOSFETs and maximum IC supply voltage.



## Revision History

Revision	Date	Description
1.0	13-Mar-2018	Initial Version

## IMPORTANT NOTICE AND DISCLAIMER

RENESAS ELECTRONICS CORPORATION AND ITS SUBSIDIARIES (“RENESAS”) PROVIDES TECHNICAL SPECIFICATIONS AND RELIABILITY DATA (INCLUDING DATASHEETS), DESIGN RESOURCES (INCLUDING REFERENCE DESIGNS), APPLICATION OR OTHER DESIGN ADVICE, WEB TOOLS, SAFETY INFORMATION, AND OTHER RESOURCES “AS IS” AND WITH ALL FAULTS, AND DISCLAIMS ALL WARRANTIES, EXPRESS OR IMPLIED, INCLUDING, WITHOUT LIMITATION, ANY IMPLIED WARRANTIES OF MERCHANTABILITY, FITNESS FOR A PARTICULAR PURPOSE, OR NON-INFRINGEMENT OF THIRD-PARTY INTELLECTUAL PROPERTY RIGHTS.

These resources are intended for developers who are designing with Renesas products. You are solely responsible for (1) selecting the appropriate products for your application, (2) designing, validating, and testing your application, and (3) ensuring your application meets applicable standards, and any other safety, security, or other requirements. These resources are subject to change without notice. Renesas grants you permission to use these resources only to develop an application that uses Renesas products. Other reproduction or use of these resources is strictly prohibited. No license is granted to any other Renesas intellectual property or to any third-party intellectual property. Renesas disclaims responsibility for, and you will fully indemnify Renesas and its representatives against, any claims, damages, costs, losses, or liabilities arising from your use of these resources. Renesas' products are provided only subject to Renesas' Terms and Conditions of Sale or other applicable terms agreed to in writing. No use of any Renesas resources expands or otherwise alters any applicable warranties or warranty disclaimers for these products.

(Disclaimer Rev.1.01 Jan 2024)

### Corporate Headquarters

TOYOSU FORESIA, 3-2-24 Toyosu,  
Koto-ku, Tokyo 135-0061, Japan  
[www.renesas.com](http://www.renesas.com)

### Trademarks

Renesas and the Renesas logo are trademarks of Renesas Electronics Corporation. All trademarks and registered trademarks are the property of their respective owners.

### Contact Information

For further information on a product, technology, the most up-to-date version of a document, or your nearest sales office, please visit [www.renesas.com/contact-us/](http://www.renesas.com/contact-us/).