

Introduction

A growing number of mobile devices have video output ports. These ports must drive video signals conforming to display standards. For example, NTSC video is a 1V peak signal driven into 75Ω lines. If the circuit uses termination at both ends of the cable, the signal from the video driver output must be 2V. In many cases, the video ASICs (encoders) are built on low-voltage platforms, using 1.8V or even lower-voltage supplies. In these cases, a video buffer is needed to raise the signal to proper driving levels.

In addition, the video signal must be AC-coupled to prevent undesired current into the load and unwanted draining of the portable battery. The AC output capacitance, typically 220μF, needs to be large to preserve the low-frequency contents of the video signal. Physically, a 220μF capacitor is very large, which is too large for mobile devices like cell phones or MP3 players.

First, the traditional AC coupling technique for transmitting video signals is presented with the associated design trade-offs. Multiple improvements are then discussed. Then, a SAG feedback network is applied to minimize the output capacitance. The traditional technique can also be improved by the addition of a charge pump. Finally, a DC-restore circuit is added at the input of the video driver. In this case, two of the three original coupling capacitors are eliminated and the third is drastically reduced.

Since design choices in all four cases are made for similar performance, the circuits can be compared in terms of size of coupling capacitors, power supply noise and board area. A table is provided to facilitate an understanding of the strengths and weaknesses of each improvement.

Traditional AC-Coupling Technique

The traditional technique for transmitting signals with single-supply is shown in [Figure 1](#).

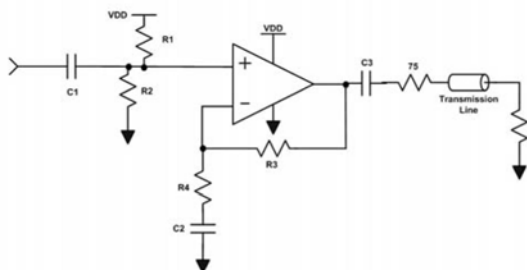

R1 = 10k	R _{LOAD} = 150	R2 = 10k	C1 = 6.5μF
R4 = 1k	C2 = 33μF	R5 = 1k	C3 = 220μF

FIGURE 1. TRADITIONAL TECHNIQUE FOR TRANSMITTING VIDEO SIGNALS

Resistors R1 and R2 set the bias voltage at the input of the amplifier, placing it in the linear operating region. The parallel combination of R1 and R2 form a low frequency pole with C1. The values of R1 and R2 are set by the video driver's input bias current. If they are too large, the offset voltage at the input will be unacceptably large as well. Since their sizes are limited, C1 must be sufficiently sized to guarantee that the input pole is lower than the minimum video signal frequency.

C2 is required to keep the DC gain at unity. The size of C2 is determined by R3 and R4 values. For a current feedback amplifier, the feedback resistor R3 is predetermined by the amplifier design. For a voltage feedback amplifier, the feedback resistor value is limited by the interconnecting parasitic capacitance at the inverting input of the amplifier. A large feedback resistor and excessive parasitic capacitance will lead to instability problems. The parasitic capacitance can be minimized to approximately 3pF with short traces and good layout.

C3 is needed to avoid putting unnecessary DC bias voltage into the load. The size of this capacitor is determined by the line impedance, typically 75Ω, and the minimum signal frequency.

These three poles occur in close proximity so their effect is additive. Therefore, all three poles must be placed well below the desired cut-off frequency. For the example of a video system, the lowest frequency of interest is the vertical sync at 60Hz.

The effects of pole placement on the low-side cut-off frequency of a video driver system are shown in [Figure 2](#).

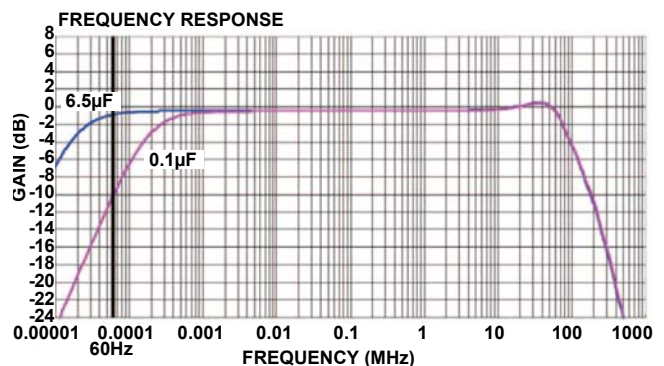

FIGURE 2. TIME DOMAIN INPUT AND OUTPUT OF VIDEO DRIVER WITH C1 = 0.1μF AND C1 = 6.5μF

The curves are displayed for the circuit in [Figure 1](#) with two values of C1; 0.1μF and 6.5μF. With the 0.1μF capacitor, the pole appears at 318Hz and a 60Hz signal is attenuated by 11dB. With a 6.5μF capacitor, the pole is lowered to 6Hz, allowing a 60 Hz signal to pass with less than 1dB of attenuation.

The effect in the time domain ([Figure 3](#)) is drastic.

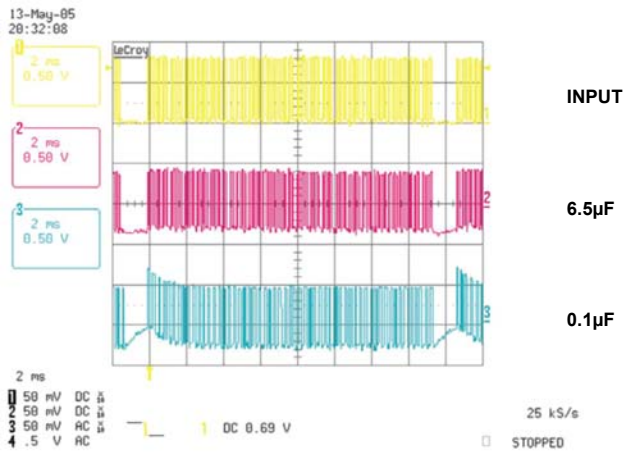

FIGURE 3. MICROCONTROLLER U2 CONTROLS A LOW-POWER DC MOTOR USING THE QUAD-SPST ANALOG SWITCH U1

The input to the video driver is plotted in yellow. The output with $C1 = 6.5\mu\text{F}$, a respectable duplicate, is plotted in pink. Finally, the output with $C1 = 0.1\mu\text{F}$ is plotted in blue. The capacitance is small enough that the voltage drifts up during the sync pulse, throwing off the average value once the video information returns. This offset corrupts the intensity information of the video signal.

Thus far, we have argued that larger capacitance is better for video systems since it reduces the low frequency pole and preserves the low frequency contents of the video signal. How large is reasonable? Size and cost provide an upper bound for capacitance value at $220\mu\text{F}$.

Reducing the Output Capacitance (C3) with Feedback

In many cases, $220\mu\text{F}$ is physically too large to be included on a board. A feedback network can be added to create an effectively large output coupling capacitance (Figure 4).

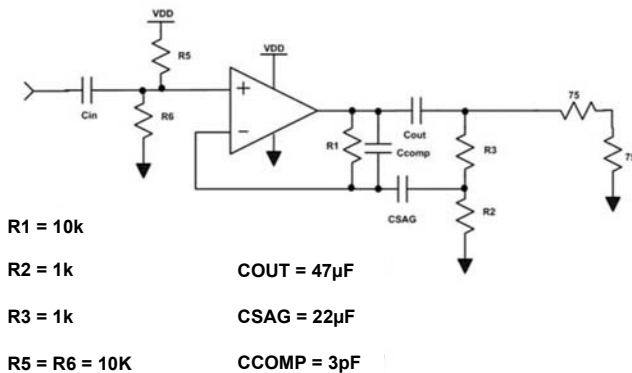

FIGURE 4. ADJUSTED VIDEO DRIVER CIRCUIT WITH FEEDBACK TO REDUCE OUTPUT CAPACITANCE

The primary trade-off with this set-up is capacitive size versus load on the driver. Simplistically, if the capacitor is 3 times smaller, the driver must drive three times harder to deliver the same signal to the load. The additional output swing may suffer from issues of linearity.

The area consumed by this feedback network is relatively small, despite the number of components. $R1$, $R2$, and $R3$ can be very small and placed close to the inverting input. The size and proximity reduces the parasitic capacitance.

A plot of the gain versus frequency for C_{sag} (the feedback capacitance) varied from $1\mu\text{F}$ to $220\mu\text{F}$ is shown in Figure 5.

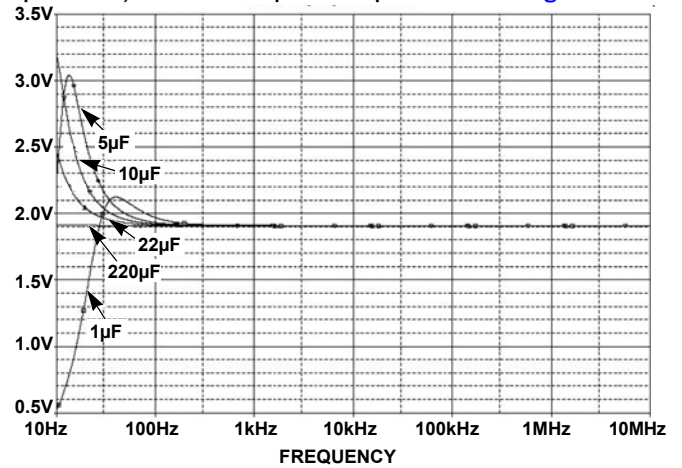

FIGURE 5. GAIN PLOT FOR VIDEO DRIVER WITH FEEDBACK NETWORK WITH VARIOUS C_{SAG}

The lower cut-off is extended through peaking. When the feedback capacitance is $1\mu\text{F}$, that extension is not enough to pass the vertical sync information. For all plotted values greater than $1\mu\text{F}$, the lower cut-off is sufficient. Larger values can be used, but will affect settling time.

The most appealing aspect of the circuit in Figure 4 is the dual function of C_{sag} . In this configuration, $C2$ is not needed. C_{sag} provides the feedback to scale the output capacitance, as well as the unity-gain DC characteristic formerly provided by $C2$. C_{comp} is added instead of $C2$, but since it utilizes the Miller effect, it is three orders of magnitude smaller than the original $C2$.

Creating Dual Supplies with a Charge Pump

One of the primary motivations for including coupling capacitors was the migration of designs from dual supply to single supply. A charge pump is a separate IC that creates a negative supply. Adding a charge pump (Figure 6) allows the designer to eliminate the output capacitance, but with added cost, increased noise, and larger power dissipation.

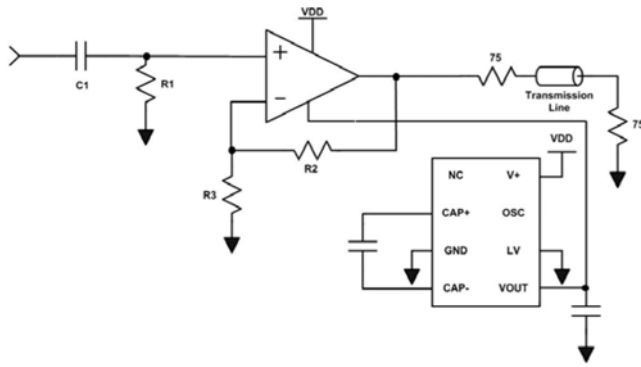

FIGURE 6. VIDEO DRIVER WITH CHARGE PUMP

The input coupling capacitance, C_1 , is still needed to remove the DC content of the video signal.

The limitations of this option are dependent on the characteristics of the charge pump. Since a switching circuit is used to create the opposite polarity of voltage, the frequency of this switching will appear as noise on our negative power supply and in our circuit. This conversion is imperfect, so a positive input of 5V can be used to create about -3.5V with a diode-based charge pump. A charge pump with integrated FET switches can create -4.5V.

To reduce area with minimum trade-offs, a video driver with a built-in charge pump, such as the ISL59833, can be used. The internal noise has been minimized and the power supply rejection is 62dB. The output exhibits a 10mV peak-to-peak signal at 167MHz. With a maximum video frequency of 200MHz, this switching noise is well out of the signal range.

Using a DC-restore to Reduce Coupling Capacitance

The addition of a DC-restore circuit can reduce all three of the external AC coupling capacitors in [Figure 1](#). [Figure 7](#) shows the block diagram of a DC-restore circuit.

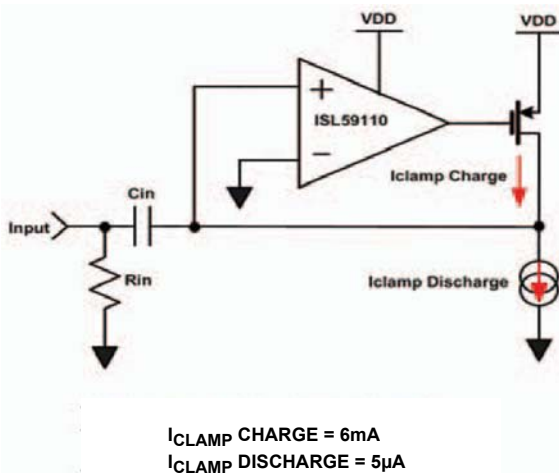

FIGURE 7. BLOCK DIAGRAM OF DC-RESTORE CIRCUITRY

It consists of four simple sections: an input RC network, an op amp configured as a buffer, a FET switch, and a current source. In the absence of an input signal, R_{in} drains the input node to ground. The op amp loop has negative feedback through the inversion provided by the FET, keeping the non-inverting input equal to the inverting input. The discharge current drains the input capacitance except when the FET switch is turned on. This action eliminates the intensity abnormalities highlighted in [Figure 3](#).

In addition, it drastically reduces the size of the capacitor needed at the input. The value of the pole is no longer subject to the value of bias resistors, but to the output impedance of the current source. Since the output impedance of current sources is designed to be large, the value of C_{in} is smaller than in the traditional techniques (where it was called C_1). Because the value of the current source is set by design parameters, C_{in} must be chosen appropriately. Changing the value of C_{in} will still cause changes in the input pole as reflected in the time domain plots shown in [Figure 2](#). Again, if the value of C_{in} is too small, the intensity of the video signal will be compromised ([Figure 8](#)).

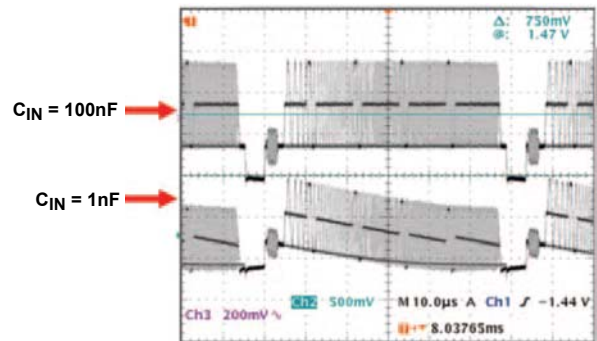

FIGURE 8. VIDEO SIGNAL THROUGH DC-RESTORE CIRCUIT WITH $C_{IN} = 100\text{nF}$ AND $C_{IN} = 1\text{nF}$

A value of 100 nF is large enough to eliminate the offset.

In the traditional video driver circuit, increasing coupling capacitor values improves performance. However, raising the DC-restore input capacitance above 100nF increases its associated time constant and only adds to the set-up time of the circuit. Recalling the traditional technique of [Figure 1](#) where C_1 is equal to 6.5µF, this method has reduced the input capacitance by a factor of 65.

It is noteworthy that an IC has been added to achieve this reduction in input capacitor size. The additional board area is justified when considering the affect on the other two coupling capacitors. The complete video driver with DC-restore is shown in [Figure 9](#).

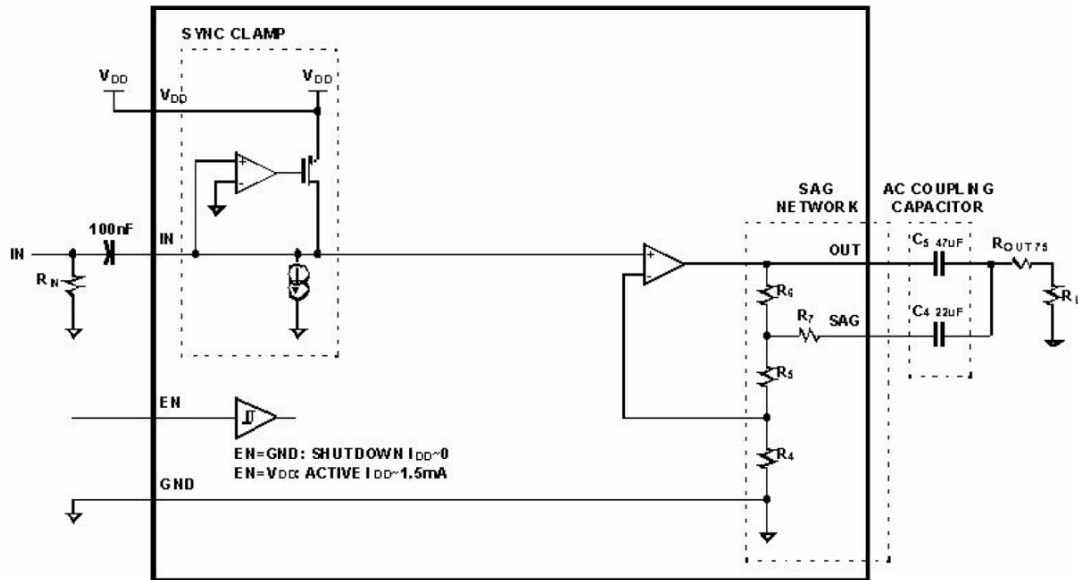

FIGURE 9. VIDEO DRIVER WITH BUILT IN DC-RESTORE

The output AC coupling capacitance, C3, is reduced through a SAG feedback network. With an integrated feedback network, there are no PCB parasitics to be compensated, so no compensation capacitance is needed.

Notice that there is no capacitor from the inverting node of the video driver to ground (C2 in Figure 1). The output and both inputs of the video driver are biased at ground through the discharge current source and the feedback resistors of the video driver. C2 is no longer needed since the non-inverting node (and through negative feedback, the inverting node) is now biased at ground instead of mid-supply.

Comparison of AC-Coupling Techniques

The critical issues are presented in Table 1.

TABLE 1. TRADE-OFFS OF VARIOUS TECHNIQUES USED TO MINIMIZE AC COUPLING CAPACITANCE IN VIDEO DRIVERS

TECHNIQUE	C _{IN} (C1)	C _{GAIN} (C2)	C _{OUT} (C3)	SUPPLY NOISE	PCB AREA
Traditional EL5360	6.5μF	33μF	220μF	Low	Largest
SAG Compensation EL8300	6.5μF	None	47μF	Low	Large
Charge Pump ISL59833	6.5μF	None	None	High	Small (Internal CP)
DC-Restore ISL59110	0.1μF	None	47μF	Low	Small

As expected, the traditional video driver technique has the largest coupling capacitors and therefore the largest amount of printed circuit board (PCB) area. The SAG feedback network can be configured to remove C2 and reduce the output capacitance by a factor of 4. The use of a charge pump removes C2 and C3, resulting in a substantial decrease in board size.

However, the switching of the charge pump makes the power supplies noisy. Finally, consider the video driver circuit with a DC-restore on the input. This solution reduces all three of the coupling capacitors and minimizes the board area. This accomplishment adds no noise to the power supply and does not degrade the performance of the system.

Conclusion

Many types of video driver circuits for mobile devices have been discussed. If the traditional technique must be adapted to minimize board space, there are three options available. First, a SAG feedback network can be used to reduce the output coupling capacitance. Secondly, a charge pump can be added to create a negative supply. Lastly, a DC-Restore network can be configured at the input of the video driver to set the bias conditions of the op amp. This substitution allows for the reduction or elimination of all of the large AC coupling capacitors typically used in video drivers, ensuring minimal size for mobile product design.

Notice

1. Descriptions of circuits, software and other related information in this document are provided only to illustrate the operation of semiconductor products and application examples. You are fully responsible for the incorporation or any other use of the circuits, software, and information in the design of your product or system. Renesas Electronics disclaims any and all liability for any losses and damages incurred by you or third parties arising from the use of these circuits, software, or information.
2. Renesas Electronics hereby expressly disclaims any warranties against and liability for infringement or any other claims involving patents, copyrights, or other intellectual property rights of third parties, by or arising from the use of Renesas Electronics products or technical information described in this document, including but not limited to, the product data, drawings, charts, programs, algorithms, and application examples.
3. No license, express, implied or otherwise, is granted hereby under any patents, copyrights or other intellectual property rights of Renesas Electronics or others.
4. You shall not alter, modify, copy, or reverse engineer any Renesas Electronics product, whether in whole or in part. Renesas Electronics disclaims any and all liability for any losses or damages incurred by you or third parties arising from such alteration, modification, copying or reverse engineering.
5. Renesas Electronics products are classified according to the following two quality grades: "Standard" and "High Quality". The intended applications for each Renesas Electronics product depends on the product's quality grade, as indicated below.
"Standard": Computers; office equipment; communications equipment; test and measurement equipment; audio and visual equipment; home electronic appliances; machine tools; personal electronic equipment; industrial robots; etc.
"High Quality": Transportation equipment (automobiles, trains, ships, etc.); traffic control (traffic lights); large-scale communication equipment; key financial terminal systems; safety control equipment; etc.
Unless expressly designated as a high reliability product or a product for harsh environments in a Renesas Electronics data sheet or other Renesas Electronics document, Renesas Electronics products are not intended or authorized for use in products or systems that may pose a direct threat to human life or bodily injury (artificial life support devices or systems; surgical implantations; etc.), or may cause serious property damage (space system; undersea repeaters; nuclear power control systems; aircraft control systems; key plant systems; military equipment; etc.). Renesas Electronics disclaims any and all liability for any damages or losses incurred by you or any third parties arising from the use of any Renesas Electronics product that is inconsistent with any Renesas Electronics data sheet, user's manual or other Renesas Electronics document.
6. When using Renesas Electronics products, refer to the latest product information (data sheets, user's manuals, application notes, "General Notes for Handling and Using Semiconductor Devices" in the reliability handbook, etc.), and ensure that usage conditions are within the ranges specified by Renesas Electronics with respect to maximum ratings, operating power supply voltage range, heat dissipation characteristics, installation, etc. Renesas Electronics disclaims any and all liability for any malfunctions, failure or accident arising out of the use of Renesas Electronics products outside of such specified ranges.
7. Although Renesas Electronics endeavors to improve the quality and reliability of Renesas Electronics products, semiconductor products have specific characteristics, such as the occurrence of failure at a certain rate and malfunctions under certain use conditions. Unless designated as a high reliability product or a product for harsh environments in a Renesas Electronics data sheet or other Renesas Electronics document, Renesas Electronics products are not subject to radiation resistance design. You are responsible for implementing safety measures to guard against the possibility of bodily injury, injury or damage caused by fire, and/or danger to the public in the event of a failure or malfunction of Renesas Electronics products, such as safety design for hardware and software, including but not limited to redundancy, fire control and malfunction prevention, appropriate treatment for aging degradation or any other appropriate measures. Because the evaluation of microcomputer software alone is very difficult and impractical, you are responsible for evaluating the safety of the final products or systems manufactured by you.
8. Please contact a Renesas Electronics sales office for details as to environmental matters such as the environmental compatibility of each Renesas Electronics product. You are responsible for carefully and sufficiently investigating applicable laws and regulations that regulate the inclusion or use of controlled substances, including without limitation, the EU RoHS Directive, and using Renesas Electronics products in compliance with all these applicable laws and regulations. Renesas Electronics disclaims any and all liability for damages or losses occurring as a result of your noncompliance with applicable laws and regulations.
9. Renesas Electronics products and technologies shall not be used for or incorporated into any products or systems whose manufacture, use, or sale is prohibited under any applicable domestic or foreign laws or regulations. You shall comply with any applicable export control laws and regulations promulgated and administered by the governments of any countries asserting jurisdiction over the parties or transactions.
10. It is the responsibility of the buyer or distributor of Renesas Electronics products, or any other party who distributes, disposes of, or otherwise sells or transfers the product to a third party, to notify such third party in advance of the contents and conditions set forth in this document.
11. This document shall not be reprinted, reproduced or duplicated in any form, in whole or in part, without prior written consent of Renesas Electronics.
12. Please contact a Renesas Electronics sales office if you have any questions regarding the information contained in this document or Renesas Electronics products.
(Note 1) "Renesas Electronics" as used in this document means Renesas Electronics Corporation and also includes its directly or indirectly controlled subsidiaries.
(Note 2) "Renesas Electronics product(s)" means any product developed or manufactured by or for Renesas Electronics.

(Rev.4.0-1 November 2017)



SALES OFFICES

Renesas Electronics Corporation

<http://www.renesas.com>

Refer to "<http://www.renesas.com/>" for the latest and detailed information.

Renesas Electronics America Inc.
1001 Murphy Ranch Road, Milpitas, CA 95035, U.S.A.
Tel: +1-408-432-8888, Fax: +1-408-434-5351

Renesas Electronics Canada Limited
9251 Yonge Street, Suite 8309 Richmond Hill, Ontario Canada L4C 9T3
Tel: +1-905-237-2004

Renesas Electronics Europe Limited
Dukes Meadow, Millboard Road, Bourne End, Buckinghamshire, SL8 5FH, U.K
Tel: +44-1628-651-700, Fax: +44-1628-651-804

Renesas Electronics Europe GmbH
Arcadiastrasse 10, 40472 Düsseldorf, Germany
Tel: +49-211-6503-0, Fax: +49-211-6503-1327

Renesas Electronics (China) Co., Ltd.
Room 1709 Quantum Plaza, No.27 ZhichunLu, Haidian District, Beijing, 100191 P. R. China
Tel: +86-10-8235-1155, Fax: +86-10-8235-7679

Renesas Electronics (Shanghai) Co., Ltd.
Unit 301, Tower A, Central Towers, 555 Langao Road, Putuo District, Shanghai, 200333 P. R. China
Tel: +86-21-2226-0888, Fax: +86-21-2226-0999

Renesas Electronics Hong Kong Limited
Unit 1601-1611, 16/F., Tower 2, Grand Century Place, 193 Prince Edward Road West, Mongkok, Kowloon, Hong Kong
Tel: +852-2265-6688, Fax: +852-2886-9022

Renesas Electronics Taiwan Co., Ltd.
13F, No. 363, Fu Shing North Road, Taipei 10543, Taiwan
Tel: +886-2-8175-9600, Fax: +886-2-8175-9670

Renesas Electronics Singapore Pte. Ltd.
80 Bendemeer Road, Unit #06-02 Hyflux Innovation Centre, Singapore 339949
Tel: +65-6213-0200, Fax: +65-6213-0300

Renesas Electronics Malaysia Sdn.Bhd.
Unit 1207, Block B, Menara Amcorp, Amcorp Trade Centre, No. 18, Jln Persiaran Barat, 46050 Petaling Jaya, Selangor Darul Ehsan, Malaysia
Tel: +60-3-7955-9390, Fax: +60-3-7955-9510

Renesas Electronics India Pvt. Ltd.
No.777C, 100 Feet Road, HAL 2nd Stage, Indiranagar, Bangalore 560 038, India
Tel: +91-80-67208700, Fax: +91-80-67208777

Renesas Electronics Korea Co., Ltd.
17F, KAMCO Yangjae Tower, 262, Gangnam-daero, Gangnam-gu, Seoul, 06265 Korea
Tel: +82-2-558-3737, Fax: +82-2-558-5338