

RENESAS TECHNICAL UPDATE

1753, Shimonumabe, Nakahara-ku, Kawasaki-shi, Kanagawa 211-8668 Japan
Renesas Electronics Corporation

Product Category	MPU/MCU		Document No.	TN-R8C-A036A/E	Rev.	1.00
Title	User's Manuals Regarding CAN Module		Information Category	Technical Notification		
Applicable Product	R8C/34E, R8C/34F Group	Lot No.	Reference Document	User's Manuals: Hardware of Applicable Products		
	R8C/36E, R8C/36F Group R8C/38E, R8C/38F Group R8C/34W, R8C/34X Group R8C/36W, R8C/36X Group R8C/38W, R8C/38X Group					

This document describes corrections to the chapter "CAN module" in the User's Manuals: Hardware of the above groups.

The corrections are indicated in red in the list below.

Page and chapter numbers are based on the R8C/34W Group, R8C/34X Group User's Manual:Hardware.

Refer to the User's Manual of each product for the corresponding pages and chapters in other groups.

•Page 577 of 727

The description in 26.2.19 BLIF Bit is corrected as follows:

Before correction

The BLIF bit becomes 1 if 32 consecutive dominant bits are detected on the CAN bus while the CAN module is in CAN operation mode.

After the BLIF bit becomes 1, **32 consecutive dominant bits are** detected again **under** either of the following conditions:

- After this bit is set to 0 from 1, recessive bits are detected.
- After this bit is set to 0 from 1, the CAN module enters CAN reset mode **or CAN halt mode** and then enters CAN operation mode again.

Corrections

The BLIF bit becomes 1 if 32 consecutive dominant bits are detected on the CAN bus while the CAN module is in CAN operation mode.

After the BLIF bit becomes 1, **bus lock can be** detected again **after** either of the following conditions **is satisfied**:

- After this bit is set to 0 from 1, recessive bits are detected (**bus lock is resolved**).
- After this bit is set to 0 from 1, the CAN module enters CAN reset mode and then enters CAN operation mode again (**internal reset**).

•Page 584 of 727

Note 3 is added to Figure 26.9 as follows:

Before correction

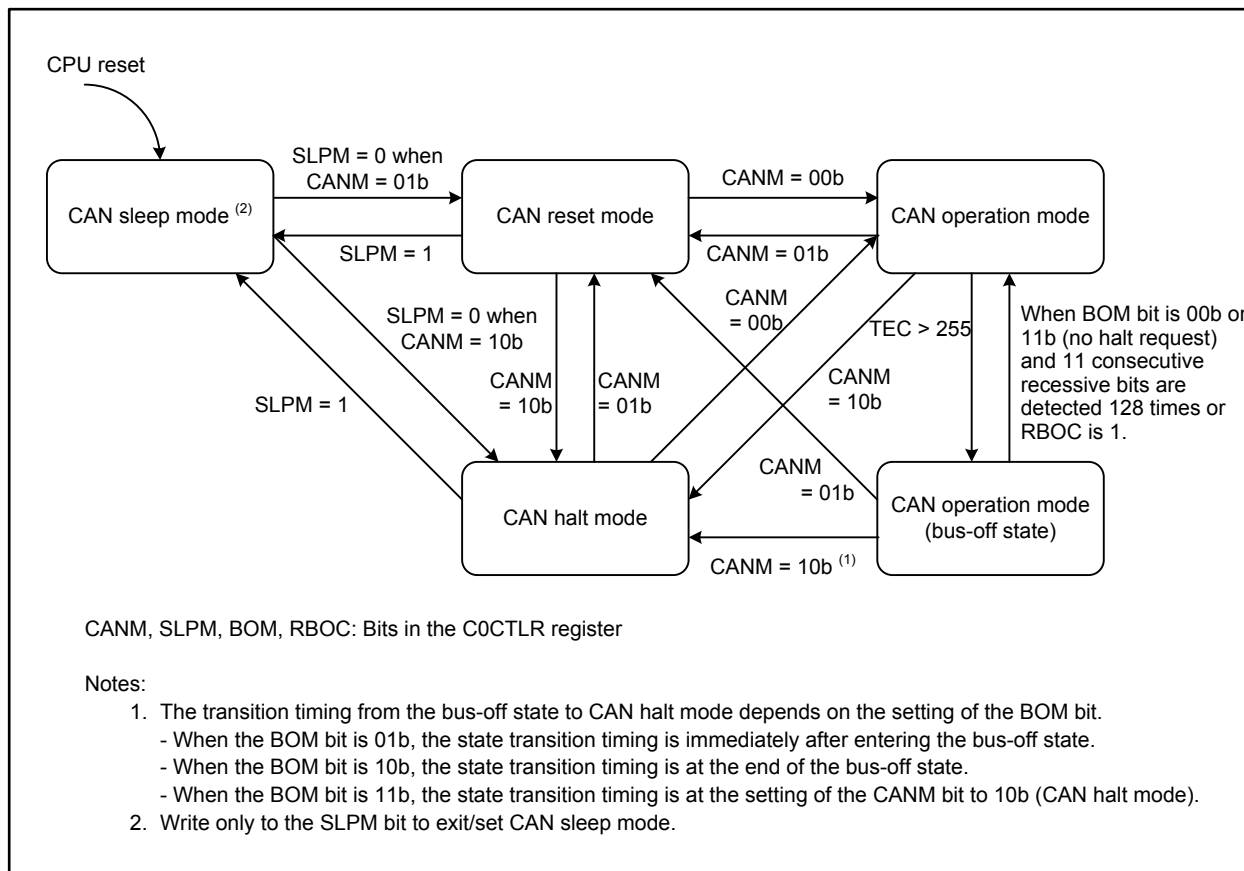

Figure 26.9 Transition between CAN Operating Modes

Corrections

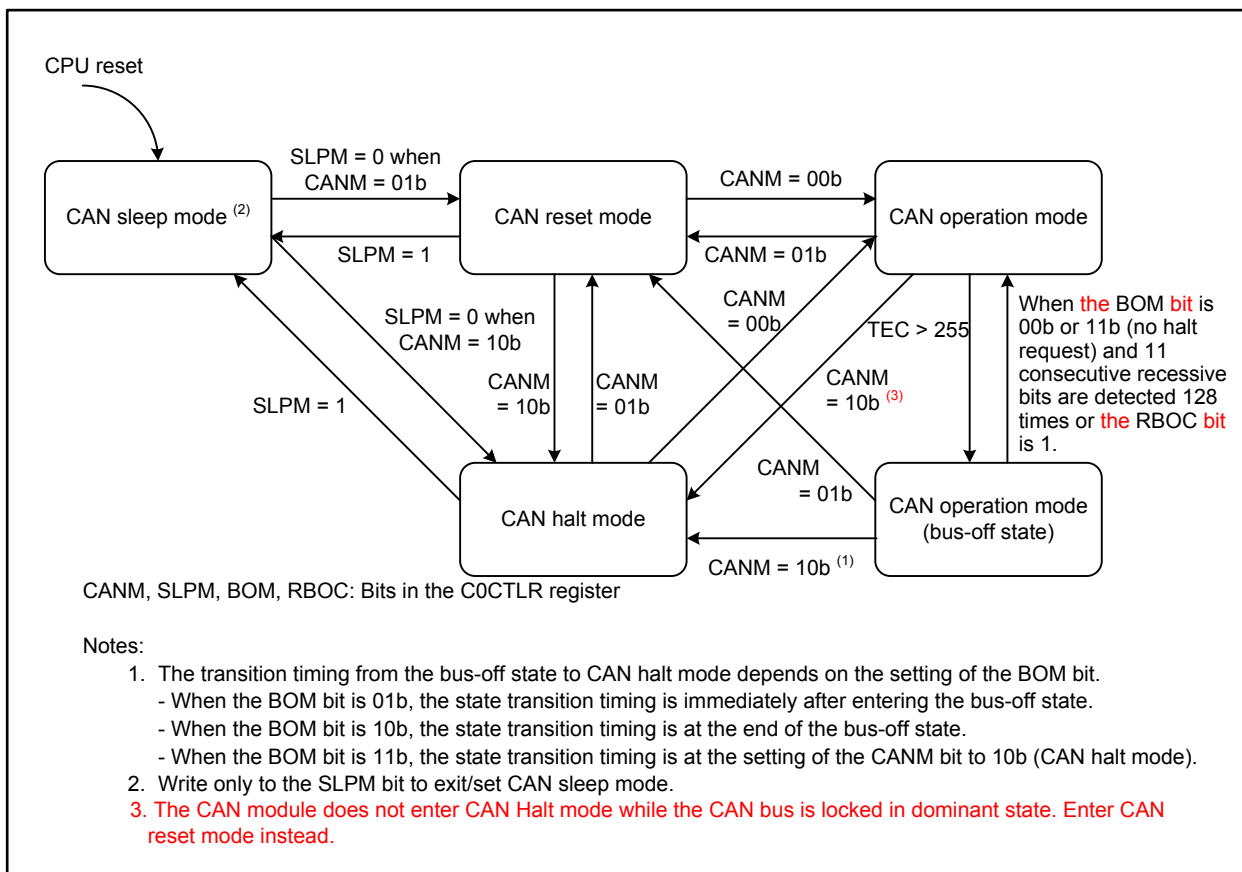

Figure 26.9 Transition between CAN Operating Modes

•Page 586 of 727

Table 26.9 is corrected as follows:

Table 26.9 Operation in CAN Reset Mode and CAN Halt Mode

Mode	Receiver	Transmitter	Bus-off
CAN reset mode	CAN module enters CAN reset mode without waiting for the end of message reception	CAN module enters CAN reset mode after waiting for the end of message transmission (1, 4)	CAN module enters CAN reset mode without waiting for the end of bus-off recovery
CAN halt mode	CAN module enters CAN halt mode after waiting for the end of message reception. (2, 3)	CAN module enters CAN halt mode after waiting for the end of message transmission. (1, 4)	[When the BOM bit is 00b] A halt request from a program will be acknowledged only after bus-off recovery. [When the BOM bit is 01b] CAN module enters automatically to CAN halt mode without waiting for the end of bus-off recovery (regardless of a halt request from a program). [When the BOM bit is 10b] CAN module enters automatically to CAN halt mode after waiting for the end of bus-off recovery (regardless of a halt request from a program). [When the BOM bit is 11b] CAN module enters CAN halt mode (without waiting for the end of bus-off recovery) if a halt is requested by a program during bus-off.

BOM bit: Bit in the C0CTLR register

Notes:

1. If several messages are requested to be transmitted, mode transition occurs after the completion of the first transmission. In a case that the CAN reset mode is being requested during suspend transmission, mode transition occurs when the bus is idle, the next transmission ends, or the CAN module becomes a receiver.
2. If the CAN bus is locked **at the dominant level**, the program can detect this state by monitoring the BLIF bit in the C0EIFR register.
3. If a CAN bus error occurs during reception after CAN halt mode is requested, the CAN **mode transits to** CAN halt mode.
4. If a CAN bus error or arbitration lost occurs during transmission after CAN reset mode or CAN halt mode is requested, the CAN **mode transits to** the requested **CAN** mode.

Corrections

Table 26.9 Operation in CAN Reset Mode and CAN Halt Mode

Mode	Receiver	Transmitter	Bus-off
CAN reset mode	CAN module enters CAN reset mode without waiting for the end of message reception	CAN module enters CAN reset mode after waiting for the end of message transmission (1, 4)	CAN module enters CAN reset mode without waiting for the end of bus-off recovery
CAN halt mode	CAN module enters CAN halt mode after waiting for the end of message reception. (2, 3)	CAN module enters CAN halt mode after waiting for the end of message transmission. (1, 2, 4)	[When the BOM bit is 00b] A halt request from a program will be acknowledged only after bus-off recovery. [When the BOM bit is 01b] CAN module enters automatically to CAN halt mode without waiting for the end of bus-off recovery (regardless of a halt request from a program). [When the BOM bit is 10b] CAN module enters automatically to CAN halt mode after waiting for the end of bus-off recovery (regardless of a halt request from a program). [When the BOM bit is 11b] CAN module enters CAN halt mode (without waiting for the end of bus-off recovery) if a halt is requested by a program during bus-off.

BOM bit: Bit in the C0CTRL register

Notes:

1. If several messages are requested to be transmitted, mode transition occurs after the completion of the first message transmission. When CAN reset mode is being requested during suspend transmission, mode transition occurs when the bus is idle, the next transmission ends, or the CAN module becomes a receiver.
2. If the CAN bus is locked in dominant state, the program can detect this state by monitoring the BLIF bit in the C0EIFR register. **The CAN module does not enter CAN Halt mode while the CAN bus is locked in dominant state. Enter CAN reset mode instead.**
3. If a CAN bus error occurs during reception after CAN halt mode is requested, the CAN module enters CAN halt mode. **However, the CAN module does not enter CAN Halt mode when the CAN bus is locked in dominant state.**
4. If a CAN bus error or arbitration lost occurs during transmission after CAN reset mode or CAN halt mode is requested, the CAN module enters the requested operating mode. **However, the CAN module does not enter CAN Halt mode when the CAN bus is locked in dominant state**