

DA7402/DA7401

Active Noise Cancellation Codec

This short datasheet is an addendum to the DA7402/DA7401 datasheet.

The DA7402/DA7401 is a high-performance, ultra-low-power, stereo (DA7402)/mono (DA7401) hi-fi codec with hybrid active noise cancellation (ANC) for USB-C™ and Bluetooth® headphone (HP), headset, or hearable applications.

With high-performance playback and record paths, DA7402/DA7401 is designed for high dynamic range and minimum latency. An integrated, programmable, digital signal processor performs noise cancellation, equalization, limiting, mixing, and gain control. A dedicated fast equalization (FEQ) path, operating at the digital microphone (DMIC) clock rate, delivers improved high-frequency noise cancellation versus alternative solutions.

Key Features

- Active noise cancellation:
 - Supports hybrid, feedforward, and feedback topologies
 - 35 dB cancellation at 200 Hz
 - 5.2 μ s input to output latency via fast equalization path
 - 25 μ s input to output latency via DSP path
 - Dedicated calibration and tuning tool
- 8.5 mW stereo (DA7402), 5.8 mW mono (DA7401) hybrid ANC playback power consumption
- JAS Hi-Res AUDIO compatible
- 4-wire digital audio interface with support for I²S, TDM, and other common audio formats:
 - Up to 32 bits per channel
 - Up to 384 kHz sample rate support
- I²C compatible control interface
- Three (DA7402)/two (DA7401) stereo PDM inputs for digital microphones and low latency connection from host processors
- Stereo analog microphone or line input path with 95 dB dynamic range
- Stereo (DA7402)/mono (DA7401) differential headphone path with 115 dB dynamic range
- Integrated low-noise microphone bias
- Flexible DSP supporting mixing, gain, equalization, sidetone, and automatic gain control
- Bypassable asynchronous sample-rate converters
- Programmable fractional-N phase-locked loop (PLL)
- WLCSP 32 ball, 3.29 mm x 1.75 mm, 0.4 mm pitch

Applications

- Headphones and headsets
- Internet of Things (IoT)
- Hearables
- Gaming and virtual reality (VR)

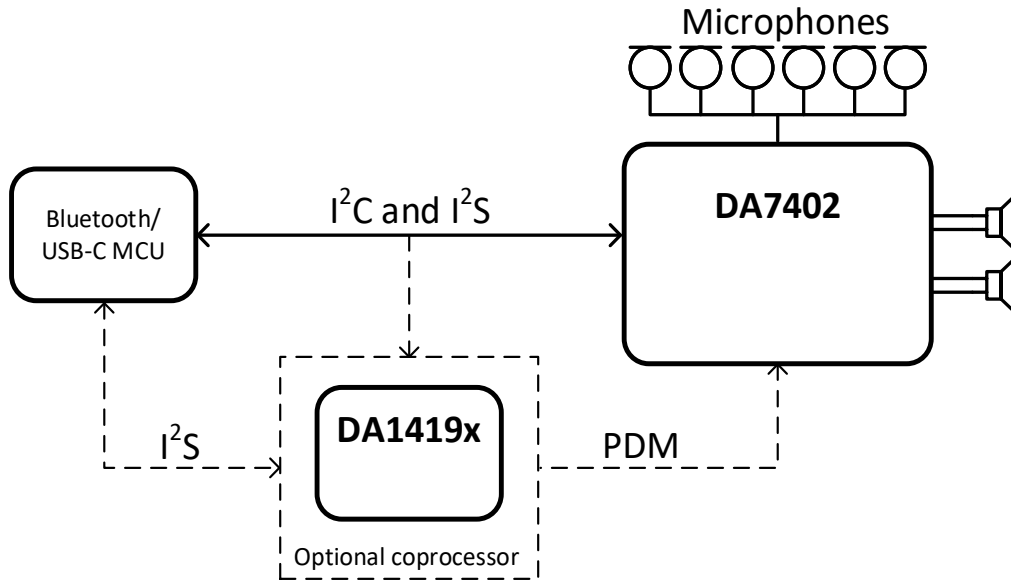

Figure 1. DA7402 system diagram

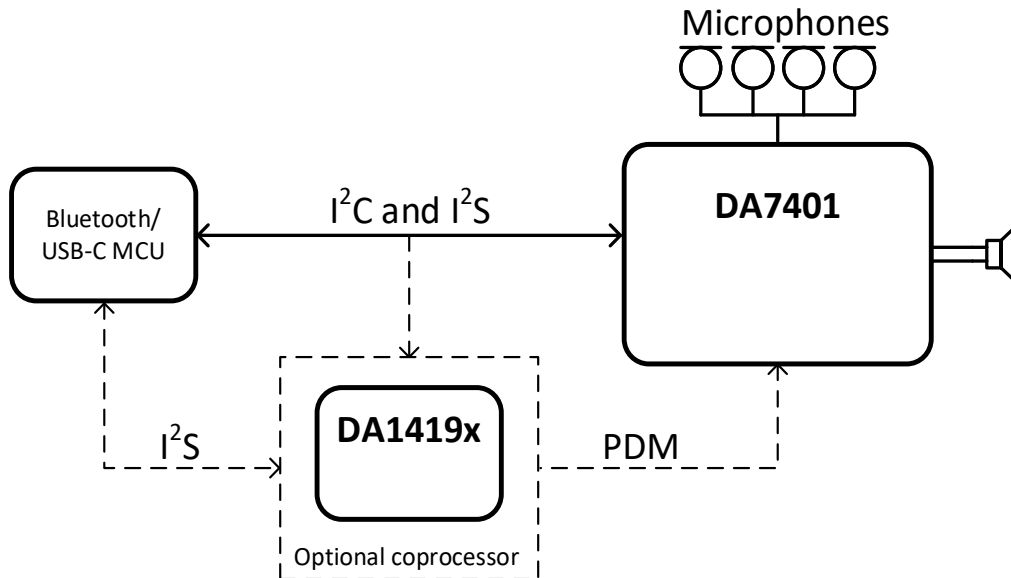

Figure 2. DA7401 system diagram

Contents

Key Features	1
Applications	1
Contents	3
Figures	3
Tables.....	3
1. Moisture Sensitivity Level	4
1.1 WLCSP Handling.....	4
1.2 Soldering Information.....	4
2. Package Outline Drawings	5
3. Ordering Information	6
4. Application Information	7
5. Layout Guidelines	8
5.1 DA7402 WLCSP	8
5.2 DA7401 WLCSP	9
6. Revision History	10

Figures

Figure 1. DA7402 system diagram	2
Figure 2. DA7401 system diagram	2
Figure 3. WLCSP32 package outline drawing.....	5
Figure 4. DA7402 external components diagram.....	7
Figure 5. DA7401 external components diagram.....	7
Figure 6. DA7402 WLCSP PCB layout.....	8
Figure 7. DA7401 WLCSP PCB layout.....	9

Tables

Table 1. MSL classification	4
Table 2. Ordering information	6

1. Moisture Sensitivity Level

The Moisture Sensitivity Level (MSL) is an indicator for the maximum allowable time period (floor lifetime) in which a moisture sensitive plastic device, once removed from the dry bag, can be exposed to an environment with a maximum temperature of 30 °C and a maximum relative humidity of 60% RH before the solder reflow process.

The WLCSP package is qualified for MSL 1.

Table 1. MSL classification

MSL level	Floor lifetime
MSL 4	72 hours
MSL 3	168 hours
MSL 2A	4 weeks
MSL 2	1 year
MSL 1	Unlimited at 30 °C/85% RH

1.1 WLCSP Handling

Manual handling of WLCSP packages should be reduced to the absolute minimum. In cases where it is still necessary, a vacuum pick-up tool should be used. In extreme cases plastic tweezers could be used, but metal tweezers are not acceptable, since contact may easily damage the silicon chip.

Removal of a WLCSP package will cause damage to the solder balls. Therefore, a removed sample cannot be reused.

WLCSP packages are sensitive to visible and infrared light. Precautions should be taken to properly shield the chip in the final product.

1.2 Soldering Information

Refer to the IPC/JEDEC standard J-STD-020 for relevant soldering information. This document can be downloaded from <http://www.jedec.org>.

2. Package Outline Drawings

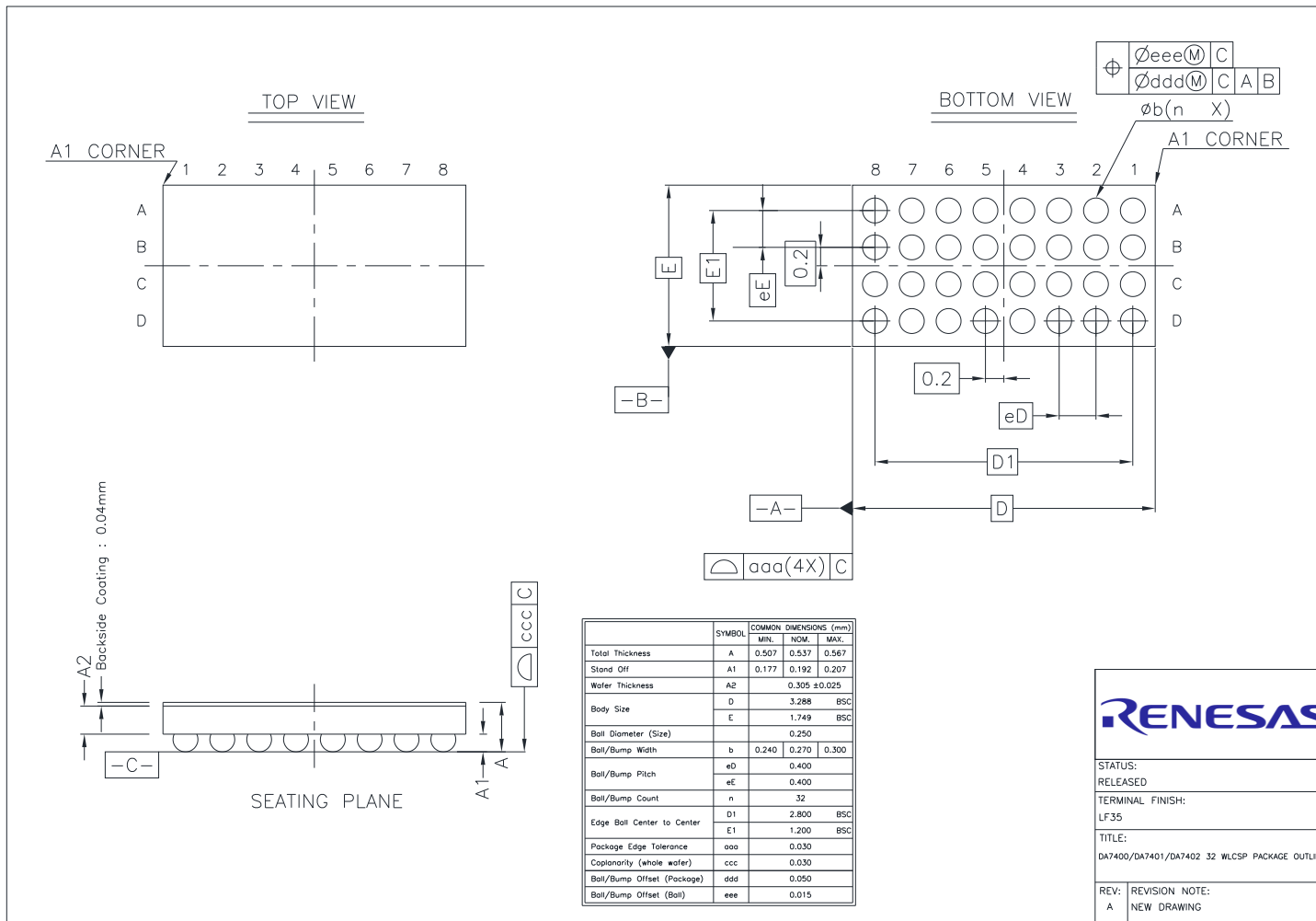

Figure 3. WLCSP32 package outline drawing

3. Ordering Information

The ordering number consists of the part number followed by a suffix indicating the packing method. For details and availability, please consult your Renesas local sales representative.

Table 2. Ordering information

Part number	Package	Size (mm)	Shipment form	Pack quantity samples	Pack quantity production
DA7402-01 000OJ2	WLCSP32	3.29 x 1.75 x 0.54	Tape and Reel	100/1000	8000
DA7401-01 000OJ2	WLCSP32	3.29 x 1.75 x 0.54	Tape and Reel	100/1000	8000

4. Application Information

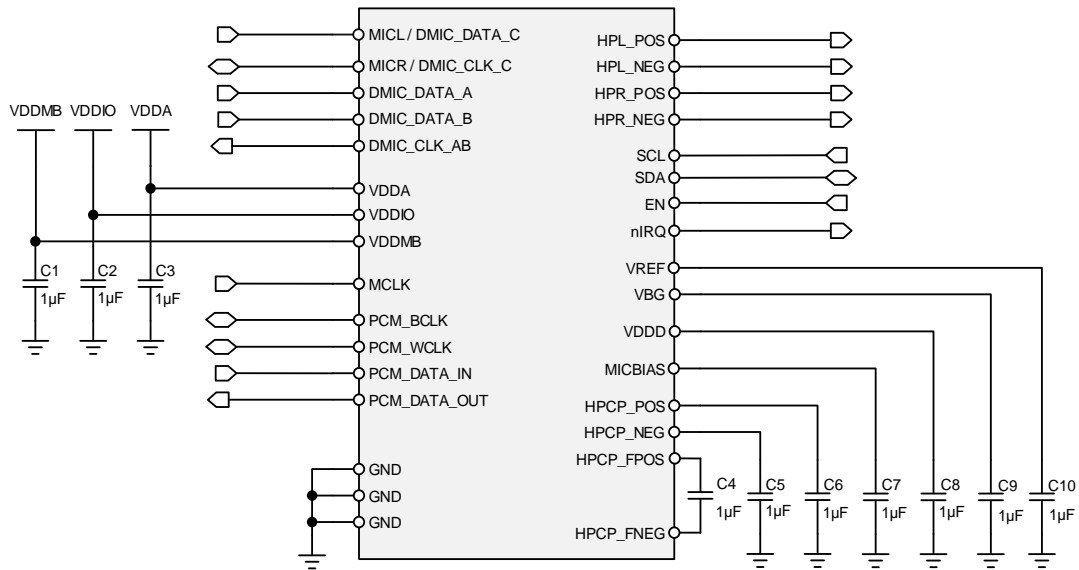

Figure 4. DA7402 external components diagram

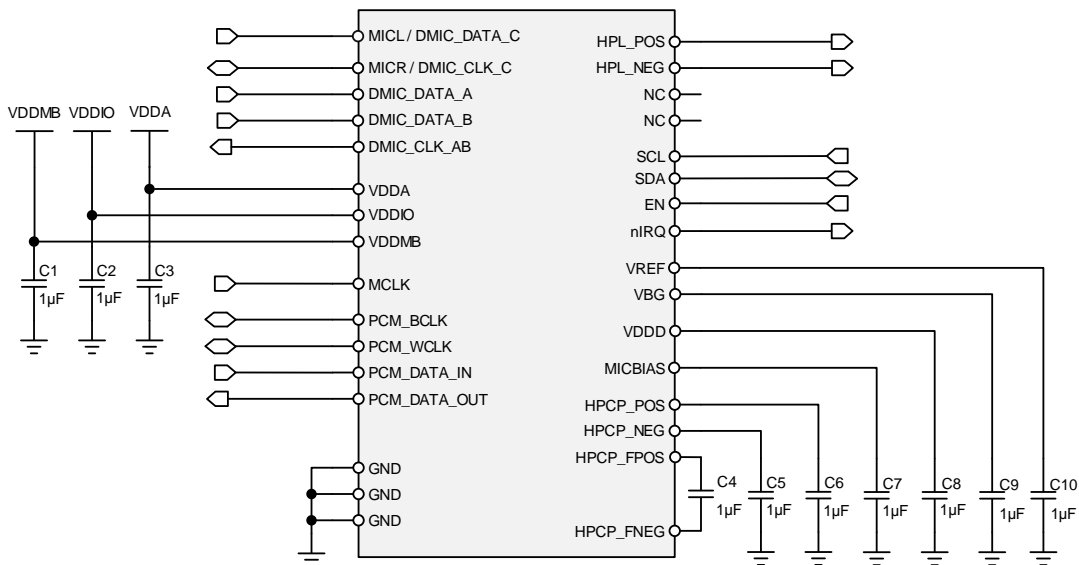

Figure 5. DA7401 external components diagram

Notes:

- Murata GRM155R61A105KE15D capacitor or similar recommended.
- DC blocking capacitors required if analog MICL and MICR inputs are used.
- C1 and C7 only required if MICBIAS is to be used.
- nIRQ is open drain and must be pulled up to VDDIO.
- SCL and SDA require pull-up resistors, typical value 2.2 kΩ.

5. Layout Guidelines

For optimal layout, place all 1 μF decoupling capacitors as close to their respective pins as possible. If optimal placing is not possible, headphone charge pump capacitors, C4, C5, and C6 in [Figure 4](#) and [Figure 5](#), carry higher currents and should be given priority. Capacitors at VBG pin (C9) and VREF pin (C10) are important and should be protected from noise coupling.

Headphone outputs are differential and should be routed as differential pairs. It is also recommended to have clearance between traces from digital pins \bullet and analog pins \bullet . GND pins and decoupling capacitors should be tied to a solid ground plane using low-impedance connections.

The WLCSP can be routed out on two layers using capacitor size 0201, see [Figure 6](#) and [Figure 7](#).

5.1 DA7402 WLCSP

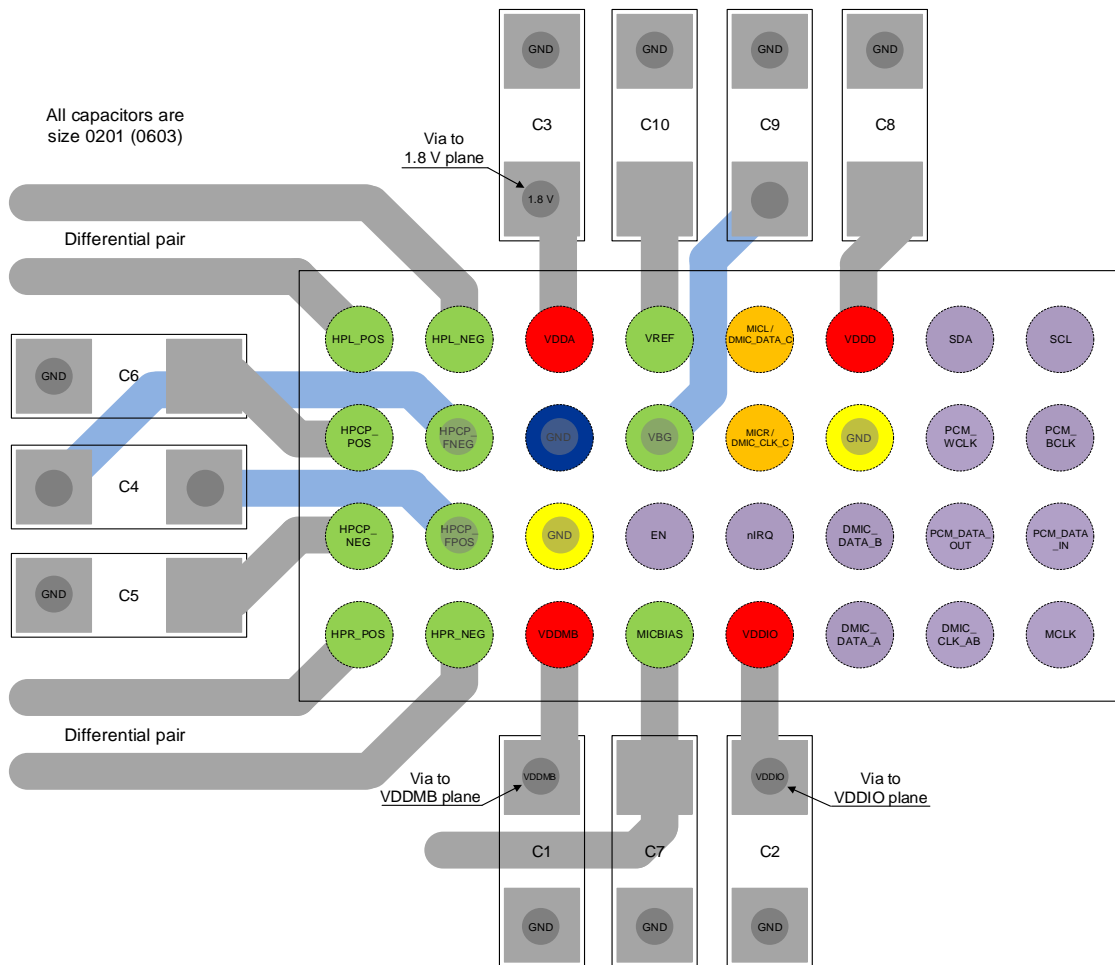

Figure 6. DA7402 WLCSP PCB layout

5.2 DA7401 WLCSP

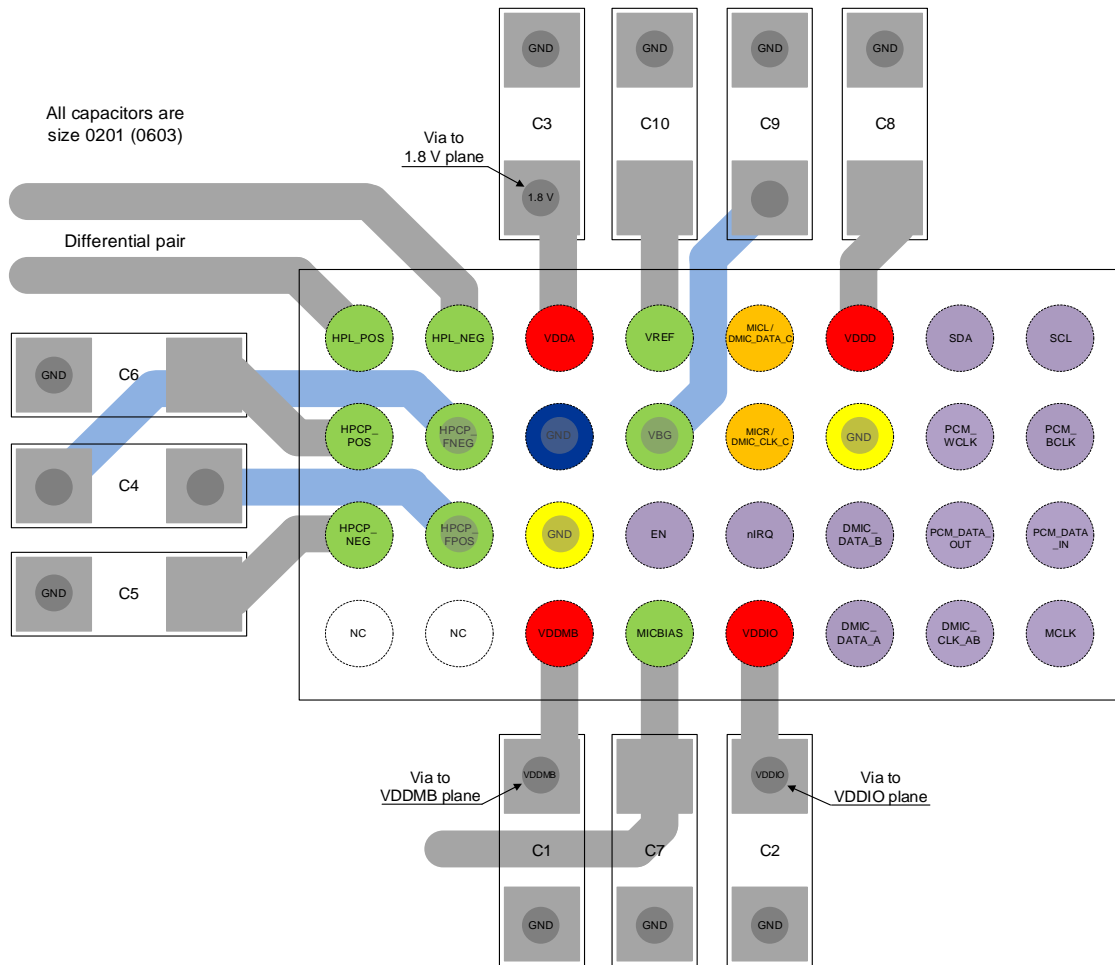

Figure 7. DA7401 WLCSP PCB layout

6. Revision History

Revision	Date	Description
01.00	June 20, 2024	First release.

RoHS Compliance

Renesas Electronics' suppliers certify that its products are in compliance with the requirements of Directive 2011/65/EU of the European Parliament on the restriction of the use of certain hazardous substances in electrical and electronic equipment. RoHS certificates from our suppliers are available on request.