

ISL75051SRH

Single Event Effects Testing of the ISL75051SRH LDO

AN1666
Rev 0.00
October 14, 2011

SEE Testing: Summary and Conclusions

Single Event Burnout/Latch-up

No Single Event Burnout (SEB) was observed for the device up to an LET value of 86 MeV.cm²/mg (+125°C). No Single Event Latch-up (SEL) were observed for the device up to an LET value of 86 MeV.cm²/mg (+125°C).

Single Event Transient

No SET on VOUT in excess of ±5% was observed at an effective LET of 86 MeV.cm²/mg. SET of up to ±4% were observed for an LET of 43 MeV.cm²/mg.

Table 1 provides an overall summary of SEE tests results.

Introduction

This application note describes the Single Event Effects (SEE) tests performed on the ISL75051SRH to characterize its Single Event Burnout (SEB), Single Event Latch-up (SEL) and Single Event Transient (SET) sensitivity. The test facility was the Cyclotron at Texas A&M Radiation Effects Test laboratory.

Reference Documents

- [ISL75051SRH Datasheet](#)
- [AN1667 "ISL75051SRH High Performance 3A LDO Evaluation Board User Guide"](#) showing ISL75051SRH evaluation board schematic and layout

Part Details

- Name: ISL75051SRH
- Function: 3A, radiation hardened, positive, ultra low dropout regulator
- Operating supply voltage: Minimum = 2.2V, Maximum = 6.0V
- Supply voltage absolute maximum: 6.7V
- Package hermetic 18 Ld dual in-line flatpack

The ISL75051SRH is a radiation hardened, low voltage, high current, single output LDO specified for up to 3.0A of continuous output current. These devices operate over an input voltage range of 2.2V to 6.0V and are capable of providing output voltages of 0.8V to 5V adjustable based on resistor divider setting. Dropout voltages as low as 65mV can be realized using the device. The OCP pin allows the short circuit output current limit threshold to be programmed by means of a resistor from the OCP pin to GND. The OCP setting range is from 0.5A minimum to 8.5A maximum. The resistor sets the constant current threshold for the output under fault conditions. The thermal shutdown feature disables the output if the device temperature exceeds the specified value, and it subsequently enters an ON/OFF cycle until the fault is removed. The ENABLE feature allows the part to be placed into a low current shutdown mode drawing about 1µA typical. When enabled, the device operates with a low ground current of 11mA typical, which provides for operation with low quiescent power consumption.

TABLE 1. OVERALL SEE TEST RESULTS (Note 1)

TEST	±1% < SET < ±4%	SET > ±5%	TEMP (°C)	LET (Note 5)	UNITS	REMARKS
SEB/L (Notes 2, 3)	–	–	+125	86	MeV.cm ² /mg	No Single Event Burnouts or Latch-up seen up to VDD = 7.1V at a fluence of 8E + 6 particles/cm ² .
SET (Note 4)	See report	None	+25	86	MeV.cm ² /mg	VIN = 2.2V/4.0V/6.0V (Note 6) VOUT = 1.8V/5.6V

NOTES:

1. SEE tests performed in a closed loop configuration. The acronym "LET" in this report is used to refer to Linear Energy Transfer.
2. SEB is said to have occurred if a 5% increase in IDD is measured after exposure to the beam. A 0.2µF capacitor was connected from the BYP pin to GND for the purpose of bypass. The 7.1V defines the absolute maximum VIN that can be applied to the device under beam. The acronym "SEB/L" in this report is used to refer to Single Effect Burnout and Latch-up.
3. SEL results: No latch-up condition observed. The acronym "SEB/L" in this report is used to refer to Single Effect Burnout and Latch-up.
4. The acronym "SET" in this report is used to refer to Single Event Transient.
5. LET of 86 was achieved by using a LET of 43 beam and rotating the test sample by 60°. The acronym "LET" in this application note is used to refer to linear energy transfer.
6. The recommended operating VIN for the device is 6.0V, which equates to a 15% derating from the Single Event Breakdown survival voltage of 7.1V.

Irradiation Test Facility

- Name: TAMU
- Location: College Station, TX
- Date: June 25, 2011
- Test Characteristics (15MeV Beam):
 - LET of 43: 10^9 Ag
 - LET of 86: 10^9 Ag at angle 60

For details on test conditions, fluence, and cross sections, see tables and plots in this application note.

Test Description

The objective of the test was to characterize the SEE performance of the LDO at the LET levels shown in "Irradiation Test Facility" on page 2. Single Event Latch-up or Burnout event occurrence (SEB/SEL) was measured under beam at a fluence of 1×10^6 particles/cm². A permanent change in the device supply current after application of the beam is indicative of a burnout condition. If the increased current is reset by cycling power, it is termed a latch-up. Single Event Transient (SET) events were measured on the output of the LDO and were in the range of

$> \pm 15\text{mV}$ to $\pm 75\text{mV}$ under beam at a fluence of 1×10^6 particles/cm². For details on SEE events and types detected during testing, see the tables and plots in this application note. Note that $\pm 75\text{mV}$ is $\pm 5\%$ of the output when $V_{\text{OUT}} = 1.5\text{V}$ and is used as a worst case condition, so for an output voltage greater than 1.5V, the SET amplitude as a percentage is smaller.

Cross-section Calculation

Cross sections are calculated as shown by Equation 1:

$$\text{CS (LET)} = N/F \tag{EQ. 1}$$

where:

- CS is the SET cross section (cm²), expressed as a function of the heavy ion LET
- LET is the Linear Energy Transfer in MeV.cm²/mg
- N is the total number of SET events
- F is Fluence in particles/cm², corrected according to the incident angle, if any.

A value of 1/F is the assumed cross section when no event is observed.

Test Set-up Diagrams

Device Block Diagram

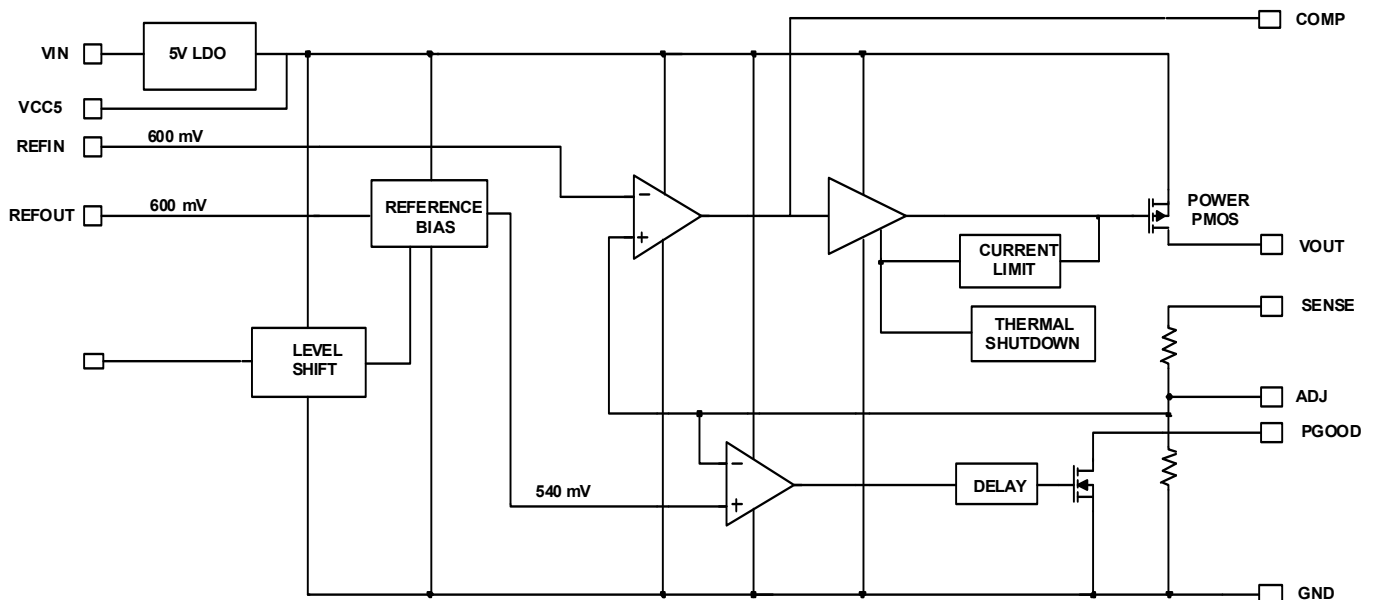

Device Pin Connections

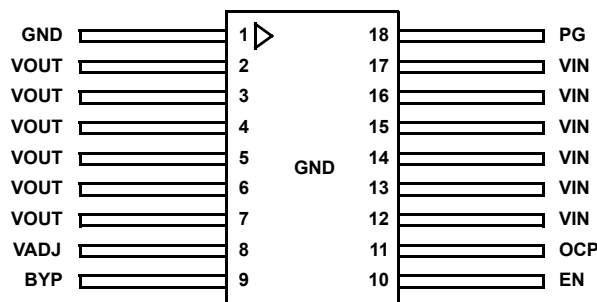

Test Set-up Description

The SEE evaluation board was wired in the configuration shown in “Schematic of SEE Evaluation Board” on page 3. The silkscreen top and bottom for the evaluation board used are shown at figure 3 and 4. The overall test set-up includes the test jig containing two evaluation boards mounted and wired through a 20-ft cable to the data room. The end of the 20-ft cable in the data room was connected to a switch board. The switch board was wired to the power supplies and monitoring equipment and scopes.

Biasing used for SEE test runs was $V_{IN} = 2.2V/4.0V/6.0V$ for $V_{OUT} = 1.8V/1.8V/5.6V$, respectively. Signals from the switch board were connected to four LECROY oscilloscopes: three set to capture transients due to V_{OUT} , and a fourth set to monitor PGOOD events in real time.

Test Method

SET events are recorded when movement on V_{OUT} due to an ion strike causes it to exceed the set window trigger of $\pm 15mV$.

- Oscilloscope 1 is set to trigger to a V_{OUT} window of $\pm 15mV$ and a trigger position at 10%. Measurements on Oscilloscope 1 are CH1 = V_{OUT} , CH2 = OCP, CH3 = BYP, CH4 = PGOOD.
- Oscilloscope 2 is set to trigger to a V_{OUT} window of $\pm 15mV$ and a trigger position at 90%. Measurements on Oscilloscope 1 are CH1 = V_{OUT} , CH2 = OCP, CH3 = BYP, CH4 = PGOOD.

- Oscilloscope 3 is set to trigger to a V_{OUT} window of $\pm 75mV$ and a trigger position at 10%. Measurements on Oscilloscope 1 are CH1 = V_{OUT} , CH2 = OCP, CH3 = BYP, CH4 = PGOOD.
- Oscilloscope 4 is set to trigger to a PGOOD falling of 200mV and a trigger position at 10%. Measurements on Oscilloscope 1 are CH1 = V_{OUT} , CH2 = OCP, CH3 = BYP, CH4 = PGOOD.

The switch board at the end of the 20-ft cabling was found to require terminations of 10nF to keep the noise on the waveforms to a minimum. It should be noted that no events of greater than $\pm 75mV$ were present at LET 86, so Oscilloscope 3 had no captures. All captured waveforms are in the range of $\pm 15mV$ to $\pm 75mV$, resulting in captures on Oscilloscopes 1 and 2; therefore, analysis in this application note summarizes these events.

Test Overview

Details of the SET tests are summarized in Tables 2 and 3. The waveforms captured for each run are plotted as a composite, along with $\pm 75mV$ limit lines that have been added to show that all captures are within the set window. The resultant plots are shown in Figures 3 through 26. The histogram plots in Figures 27 through 32 provide amplitude distribution on the Oscilloscope 1 and 2 captures.

Details of the SEB/L tests are summarized in Table 5. An overall summary of all SEE tests is shown in Table 1.

TABLE 2. DETAILS OF SET TESTS PERFORMED AT LIGHT LOAD BASED ON V_{OUT} CAPTURES

TEST ID	DEVICE#	ION	ANGLE (°)	EFF LET (MeV.cm ² /mg)	FLUENCE PER RUN (PARTICLES/cm ²)	TOTAL EVENTS	EVENT CROSS SECTION (cm ²)		
SET +25°C LET of 86 $V_{IN} = 2.2V$, $V_{OUT} = 1.8V$, $I_{OUT} = 0.1A$, $C_{OUT} = 220\mu F$, ISL75051SRH									
405	26	¹⁰⁹ Ag	60.00	86.60	$2.0 \times 10^{+6}$	227	1.14×10^{-4}		
429	11	¹⁰⁹ Ag	60.00	86.60	$2.0 \times 10^{+6}$	230	1.15×10^{-4}		
444	10	¹⁰⁹ Ag	60.00	86.60	$2.0 \times 10^{+6}$	263	1.32×10^{-4}		
446	15	¹⁰⁹ Ag	60.00	86.60	$2.0 \times 10^{+6}$	120	6.00×10^{-4}		
TOTAL FLUENCE IN PARTICLES/cm²						$8.0 \times 10^{+6}$	TOTAL EVENTS	840	1.05×10^{-4}
SET +25°C LET of 86 $V_{IN} = 4.0V$, $V_{OUT} = 1.8V$, $I_{OUT} = 0.1A$, $C_{OUT} = 220\mu F$, ISL75051SRH									
407	26	¹⁰⁹ Ag	60.00	86.60	$2.0 \times 10^{+6}$	153	7.65×10^{-5}		
431	11	¹⁰⁹ Ag	60.00	86.60	$2.0 \times 10^{+6}$	268	1.34×10^{-4}		
442	10	¹⁰⁹ Ag	60.00	86.60	$2.0 \times 10^{+6}$	199	9.95×10^{-5}		
441	15	¹⁰⁹ Ag	60.00	86.60	$2.0 \times 10^{+6}$	97	4.85×10^{-5}		
TOTAL FLUENCE IN PARTICLES/cm²						$8.0 \times 10^{+6}$	TOTAL EVENTS	717	8.96×10^{-5}
SET +25°C LET of 86 $V_{IN} = 6.0V$, $V_{OUT} = 5.6V$, $I_{OUT} = 0.1A$, $C_{OUT} = 220\mu F$, ISL75051SRH									
411	26	¹⁰⁹ Ag	60.00	86.60	$2.0 \times 10^{+6}$	508	2.54×10^{-4}		
437	11	¹⁰⁹ Ag	60.00	86.60	$2.0 \times 10^{+6}$	253	1.27×10^{-4}		
449	10	¹⁰⁹ Ag	60.00	86.60	$2.0 \times 10^{+6}$	440	2.20×10^{-4}		
451	15	¹⁰⁹ Ag	60.00	86.60	$2.0 \times 10^{+6}$	247	1.24×10^{-4}		
TOTAL FLUENCE IN PARTICLES/cm²						$8.0 \times 10^{+6}$	TOTAL EVENTS	1448	1.81×10^{-4}

TABLE 3. DETAILS OF SET TESTS PERFORMED AT MAX LOAD BASED ON V_{OUT} CAPTURES

TEST ID	DEVICE#	ION	ANGLE (°)	EFF LET (MeV.cm ² /mg)	FLUENCE PER RUN (PARTICLES/cm ²)		TOTAL EVENTS		EVENT CROSS SECTION (cm ²)
SET +25°C LET of 86 $V_{IN} = 2.2V$, $V_{OUT} = 1.8V$, $I_{OUT} = 3.0A$, $C_{OUT} = 220\mu F$, ISL75051SRH									
406	26	¹⁰⁹ Ag	60.00	86.60	$2.0 \times 10^{+6}$		255		1.28×10^{-4}
430	11	¹⁰⁹ Ag	60.00	86.60	$2.0 \times 10^{+6}$		246		1.23×10^{-4}
445	10	¹⁰⁹ Ag	60.00	86.60	$2.0 \times 10^{+6}$		253		1.27×10^{-4}
447	15	¹⁰⁹ Ag	60.00	86.60	$2.0 \times 10^{+6}$		618		3.09×10^{-4}
TOTAL FLUENCE IN PARTICLES/cm²						$8.0 \times 10^{+6}$	TOTAL EVENTS	1372	1.72×10^{-4}
SET +25°C LET of 86 $V_{IN} = 4.0V$, $V_{OUT} = 1.8V$, $I_{OUT} = 1.0A$, $C_{OUT} = 220\mu F$, ISL75051SRH									
408	26	¹⁰⁹ Ag	60.00	86.60	$2.0 \times 10^{+6}$		655		3.28×10^{-4}
432	11	¹⁰⁹ Ag	60.00	86.60	$2.0 \times 10^{+6}$		252		1.26×10^{-4}
443	10	¹⁰⁹ Ag	60.00	86.60	$2.0 \times 10^{+6}$		253		1.27×10^{-4}
448	15	¹⁰⁹ Ag	60.00	86.60	$2.0 \times 10^{+6}$		251		1.26×10^{-4}
TOTAL FLUENCE IN PARTICLES/cm²						$8.0 \times 10^{+6}$	TOTAL EVENTS	1411	1.76×10^{-4}
SET +25°C LET of 86 $V_{IN} = 6.0V$, $V_{OUT} = 5.6V$, $I_{OUT} = 3.0A$, $C_{OUT} = 220\mu F$, ISL75051SRH									
412	26	¹⁰⁹ Ag	60.00	86.60	$2.0 \times 10^{+6}$		252		1.26×10^{-4}
439	11	¹⁰⁹ Ag	60.00	86.60	$2.0 \times 10^{+6}$		252		1.26×10^{-4}
450	10	¹⁰⁹ Ag	60.00	86.60	$2.0 \times 10^{+6}$		282		1.41×10^{-4}
452	15	¹⁰⁹ Ag	60.00	86.60	$2.0 \times 10^{+6}$		251		1.26×10^{-4}
TOTAL FLUENCE IN PARTICLES/cm²						$8.0 \times 10^{+6}$	TOTAL EVENTS	1037	1.30×10^{-4}

TABLE 4. V_{OUT} SET HISTOGRAM DATA

V_{OUT} BIN (mV)	$V_{IN} = 2.2V$, $I_{OUT} = 0.1A$	$V_{IN} = 4.0V$, $I_{OUT} = 0.1A$	$V_{IN} = 6.0V$, $I_{OUT} = 0.1A$	$V_{IN} = 2.2V$, $I_{OUT} = 3.0A$	$V_{IN} = 4.0V$, $I_{OUT} = 1.0A$	$V_{IN} = 6.0V$, $I_{OUT} = 3.0A$
-75	0	0	0	0	0	1
-70	0	0	0	0	0	1
-65	0	0	0	0	0	56
-60	0	0	0	2	0	174
-55	0	0	0	286	0	159
-50	0	0	0	188	0	133
-45	0	0	0	102	0	98
-40	0	0	0	292	0	47
-35	0	0	0	93	4	8
-30	0	0	12	55	270	4
-25	0	0	142	29	509	3
-20	0	0	412	17	126	45
-15	1	2	284	28	324	89
-10	39	40	164	61	54	41

TABLE 4. V_{OUT} SET HISTOGRAM DATA (Continued)

V_{OUT} BIN (mV)	$V_{IN} = 2.2V$, $I_{OUT} = 0.1A$	$V_{IN} = 4.0V$, $I_{OUT} = 0.1A$	$V_{IN} = 6.0V$, $I_{OUT} = 0.1A$	$V_{IN} = 2.2V$, $I_{OUT} = 3.0A$	$V_{IN} = 4.0V$, $I_{OUT} = 1.0A$	$V_{IN} = 6.0V$, $I_{OUT} = 3.0A$
-5	548	341	226	165	84	70
0	252	334	211	54	40	108
5	52	35	316	5	0	109
10	107	47	28	85	7	81
15	169	142	44	660	26	17
20	104	160	359	461	849	58
25	79	88	331	66	437	69
30	53	35	198	59	16	24
35	45	47	140	36	24	237
40	73	36	29	0	20	254
45	65	41	0	0	15	150
50	30	23	0	0	4	36
55	43	16	0	0	8	2
60	20	23	0	0	3	0
65	0	24	0	0	2	0
70	0	0	0	0	0	0
75	0	0	0	0	0	0
See "SET V_{OUT} Histogram Plots for ISL75051SRH (Note 11)" on page 13	See Figure 27	See Figure 28	See Figure 29	See Figure 30	See Figure 31	See Figure 32

Typical SET Captures at $I_{OUT} = 0.1A$ (Notes 7, 8)

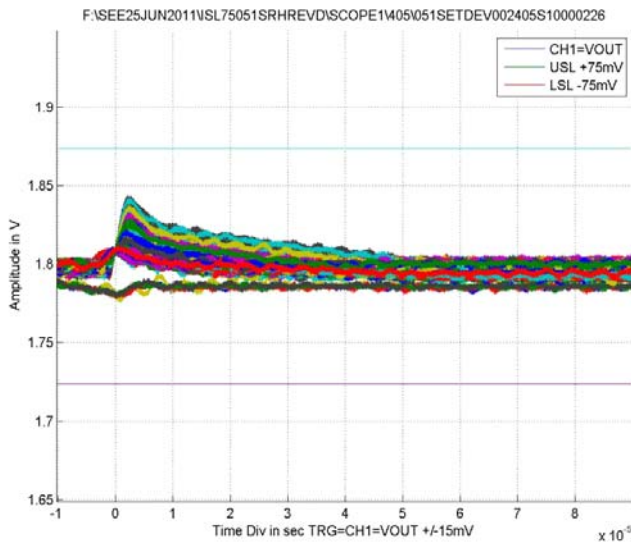

FIGURE 3. TYPICAL CAPTURE AT $V_{IN} = 2.2V$, RUN 405

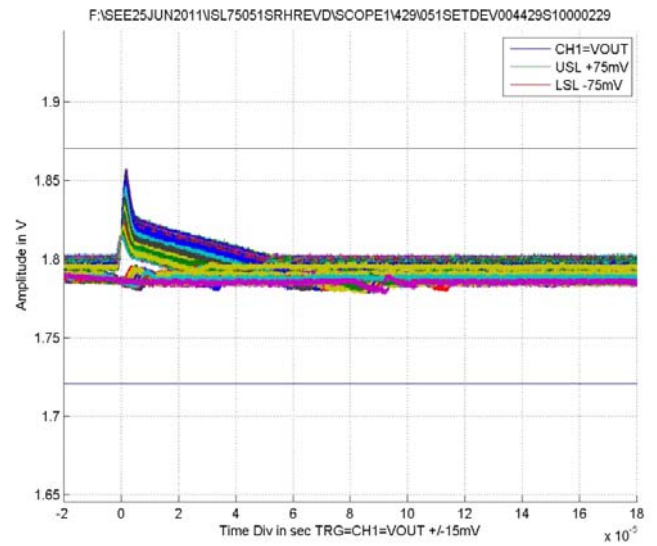

FIGURE 4. TYPICAL CAPTURE AT $V_{IN} = 2.2V$, RUN 429 (Note 8)

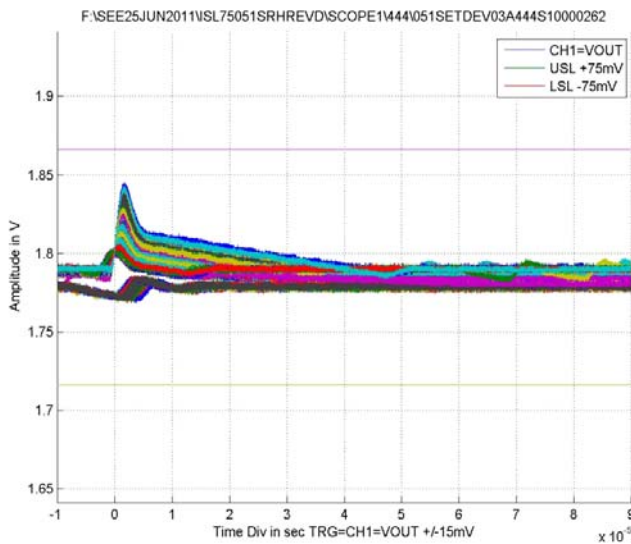

FIGURE 5. TYPICAL CAPTURE AT $V_{IN} = 2.2V$, RUN 444

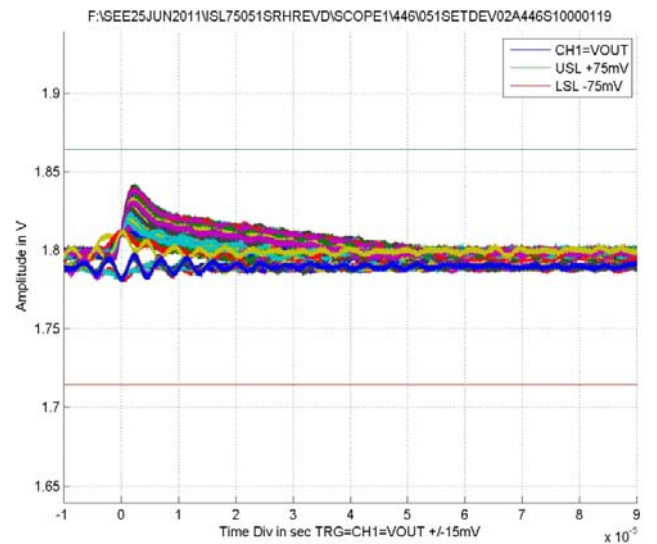

FIGURE 6. TYPICAL CAPTURE AT $V_{IN} = 2.2V$, RUN 446

Typical SET Captures at $I_{OUT} = 0.1A$ (Notes 7, 8) (Continued)

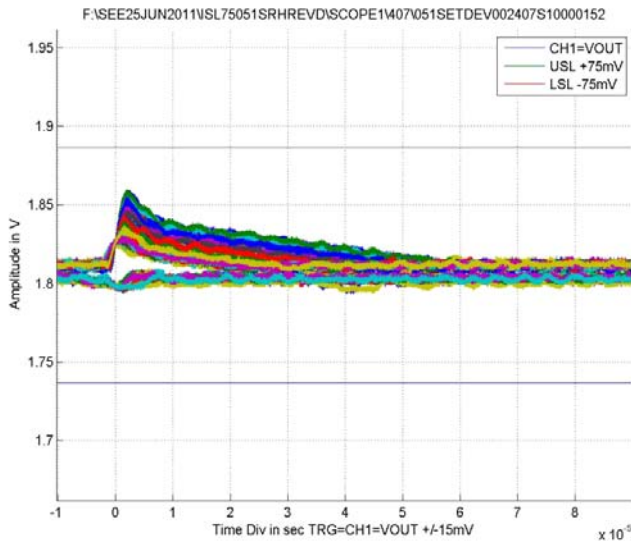

FIGURE 7. TYPICAL CAPTURE AT $V_{IN} = 4.0V$, RUN 407

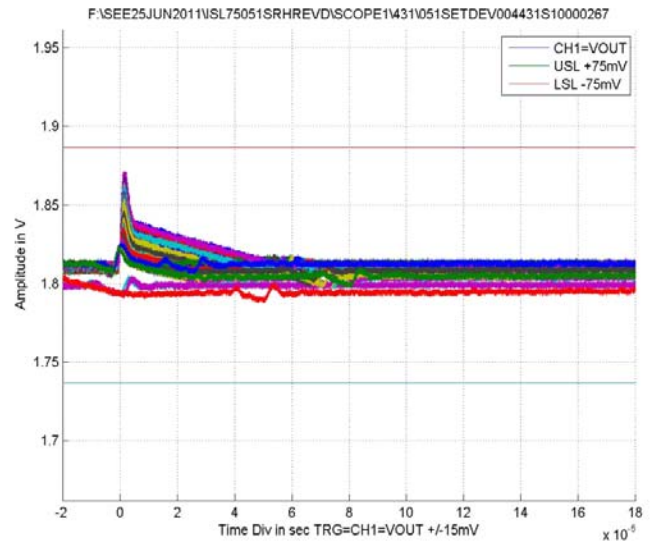

FIGURE 8. TYPICAL CAPTURE AT $V_{IN} = 4.0V$, RUN 431 (Note 8)

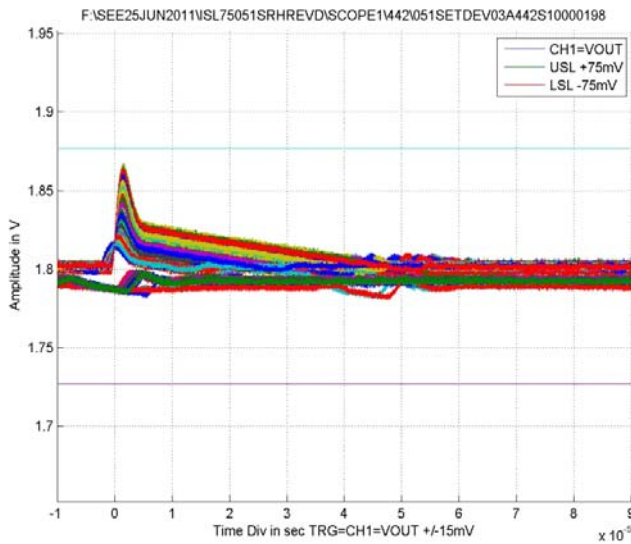

FIGURE 9. TYPICAL CAPTURE AT $V_{IN} = 4.0V$, RUN 442

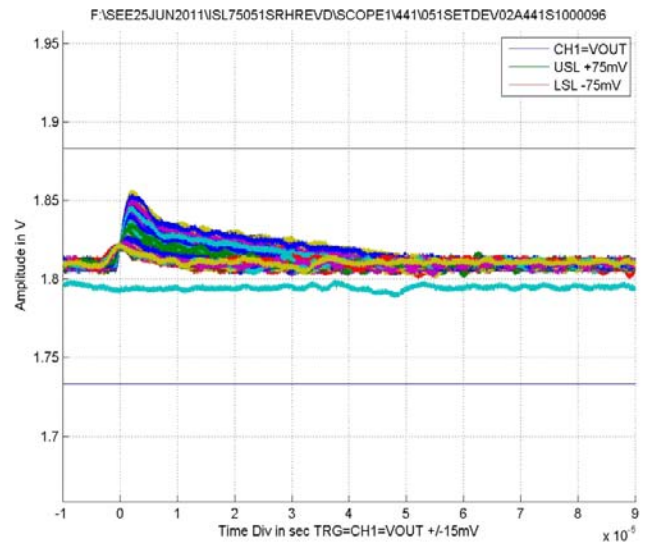

FIGURE 10. TYPICAL CAPTURE AT $V_{IN} = 4.0V$, RUN 441

Typical SET Captures at $I_{OUT} = 0.1A$ (Notes 7, 8) (Continued)

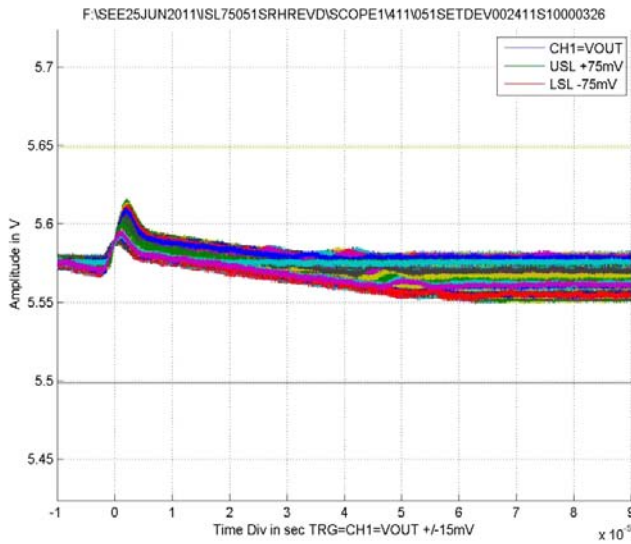

FIGURE 11. TYPICAL CAPTURE AT $V_{IN} = 6.0V$, RUN 411

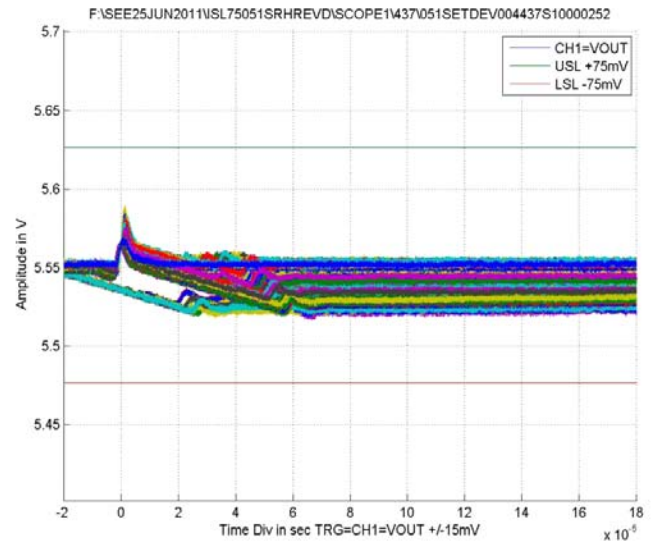

FIGURE 12. TYPICAL CAPTURE AT $V_{IN} = 6.0V$, RUN 437

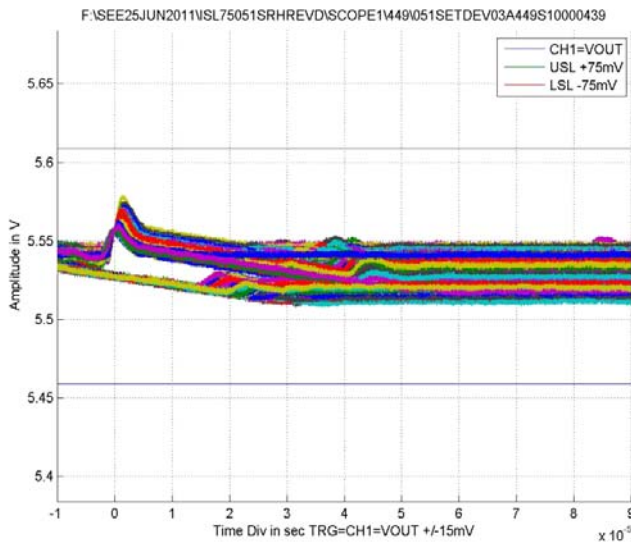

FIGURE 13. TYPICAL CAPTURE AT $V_{IN} = 6.0V$, RUN 449

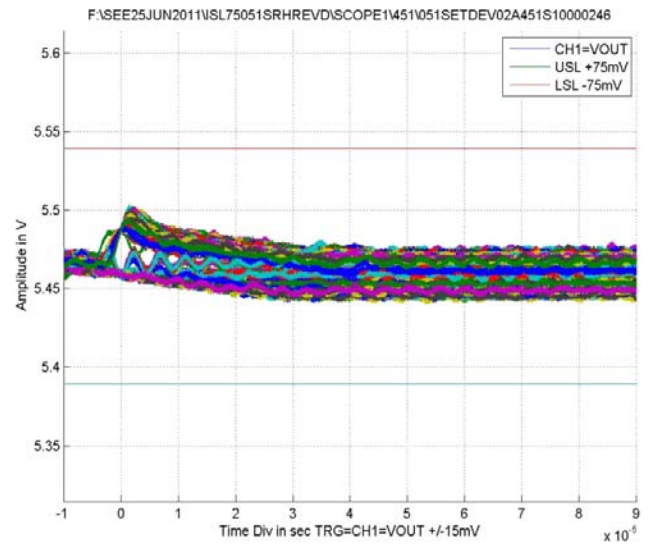

FIGURE 14. TYPICAL CAPTURE AT $V_{IN} = 6.0V$, RUN 451

NOTES:

7. Composite of all captured transients per run shown. For a distribution on the transients on V_{OUT} , see histogram data and histograms in "V_{OUT} SET HISTOGRAM DATA" on page 5 and "SET V_{OUT} Histogram Plots for ISL75051SRH (Note 11)" on page 13.
8. The horizontal axis time per division is 10μs except for Figures 4, 8, 12, 16, 20, and 24, which are at 20μs per division.

Typical SET Captures at $I_{OUT} = 1A$ (Note 7,8,9)

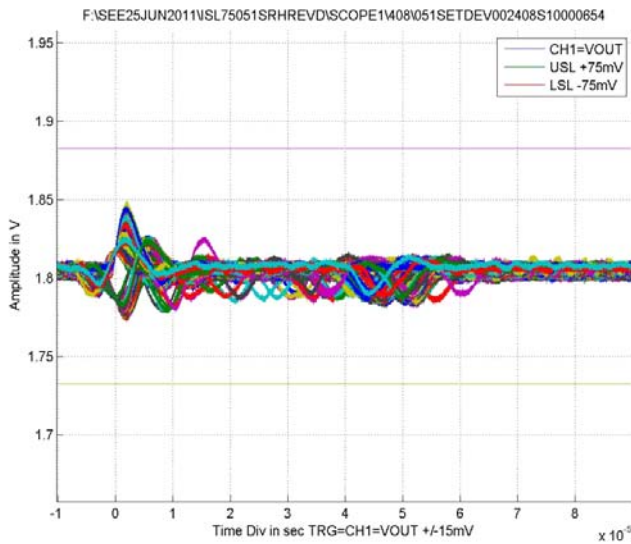

FIGURE 15. TYPICAL CAPTURE AT $V_{IN} = 4.0V$, RUN 408

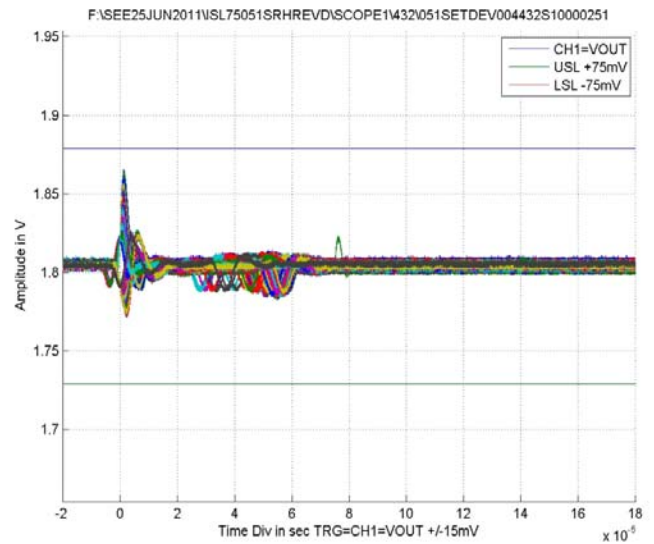

FIGURE 16. TYPICAL CAPTURE AT $V_{IN} = 4.0V$, RUN 432

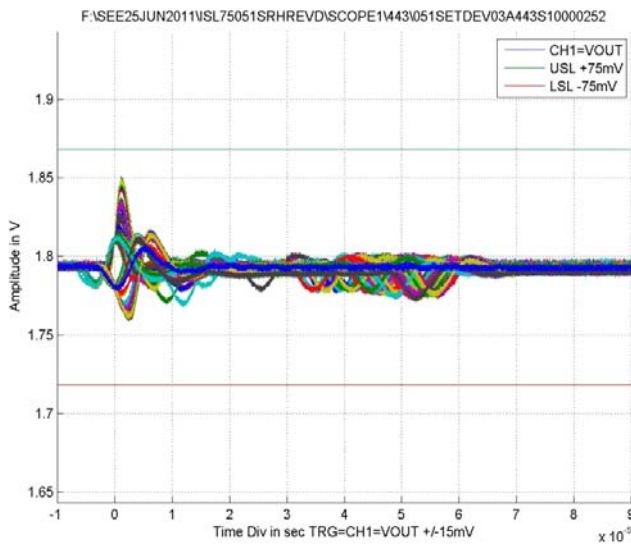

FIGURE 17. TYPICAL CAPTURE AT $V_{IN} = 4.0V$, RUN 443

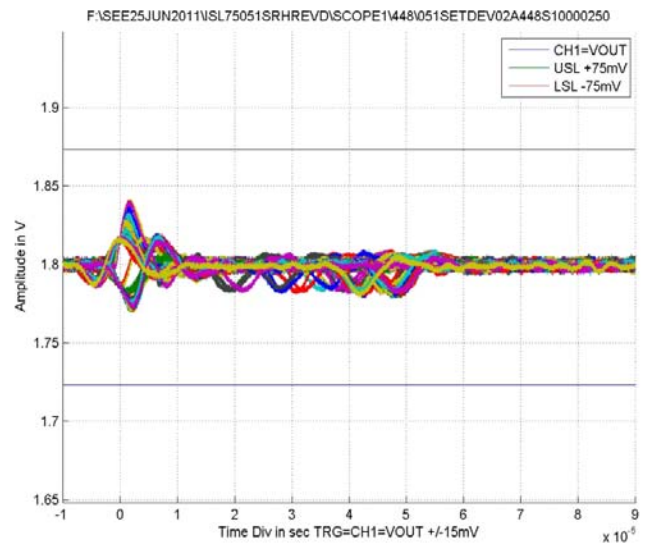

FIGURE 18. TYPICAL CAPTURE AT $V_{IN} = 4.0V$, RUN 448

NOTE:

- The waveforms signature observed in Figures 15 through 18 is caused by the handoff between main and redundant references during an SET event. This does not affect normal operation of the device.

Typical SET Captures at $I_{OUT} = 3A$ (Note 7, 8, 10)

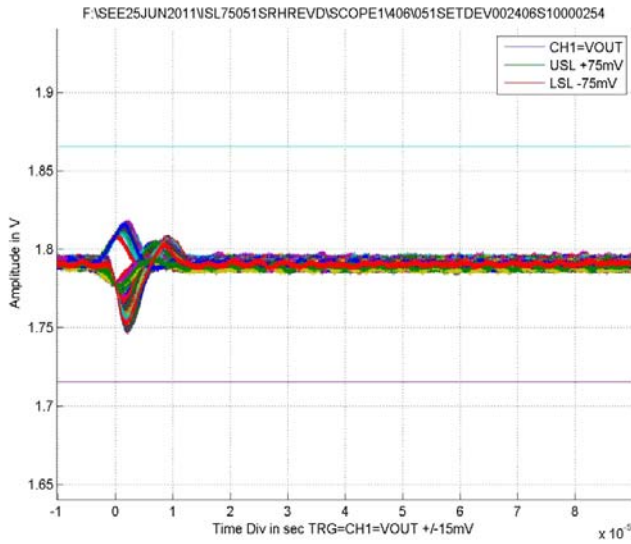

FIGURE 19. TYPICAL CAPTURE AT $V_{IN} = 2.2V$, RUN 406

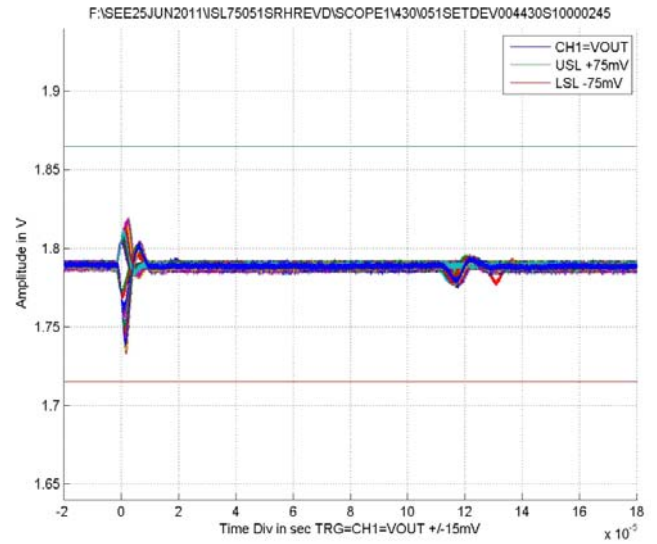

FIGURE 20. TYPICAL CAPTURE AT $V_{IN} = 2.2V$, RUN 430 (Note 8)

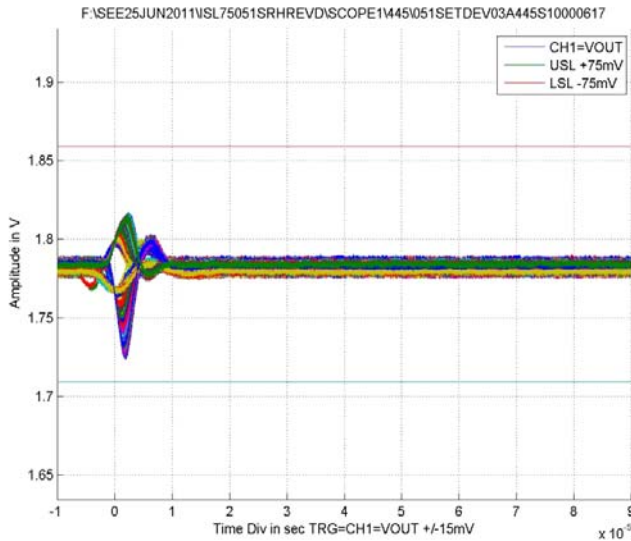

FIGURE 21. TYPICAL CAPTURE AT $V_{IN} = 2.2V$, RUN 445

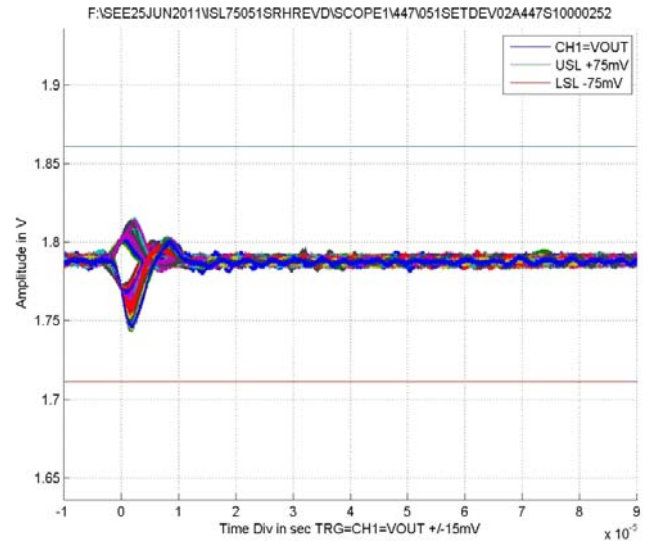

FIGURE 22. TYPICAL CAPTURE AT $V_{IN} = 2.2V$, RUN 447

Typical SET Captures at $I_{OUT} = 3A$ (Note 7, 8, 10) (Continued)

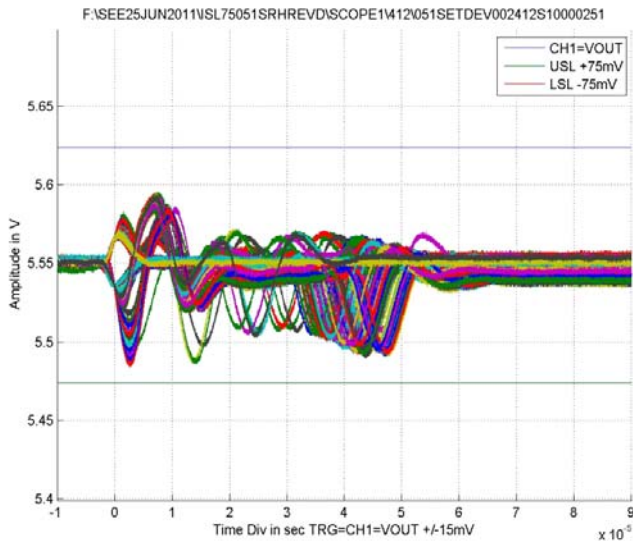

FIGURE 23. TYPICAL CAPTURES AT $V_{IN} = 6.0V$, RUN 412

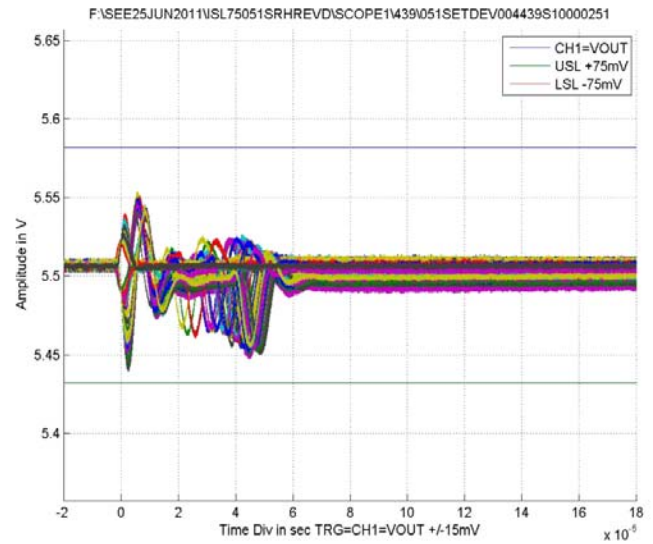

FIGURE 24. TYPICAL CAPTURES AT $V_{IN} = 6.0V$, RUN 439 (Note 8)

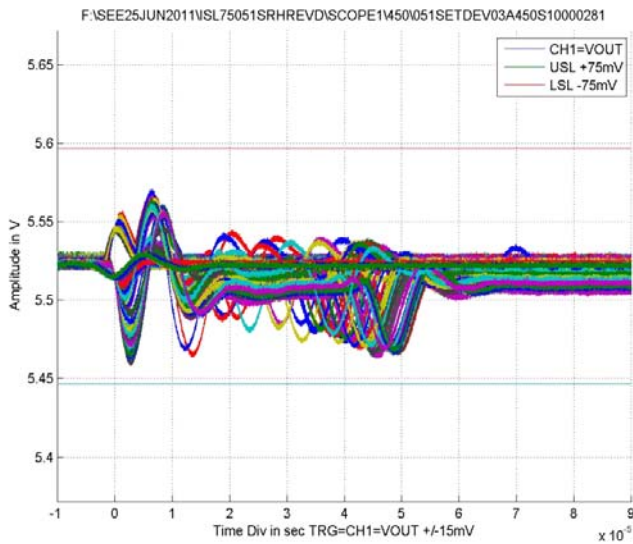

FIGURE 25. TYPICAL CAPTURE AT $V_{IN} = 6.0V$, RUN 450

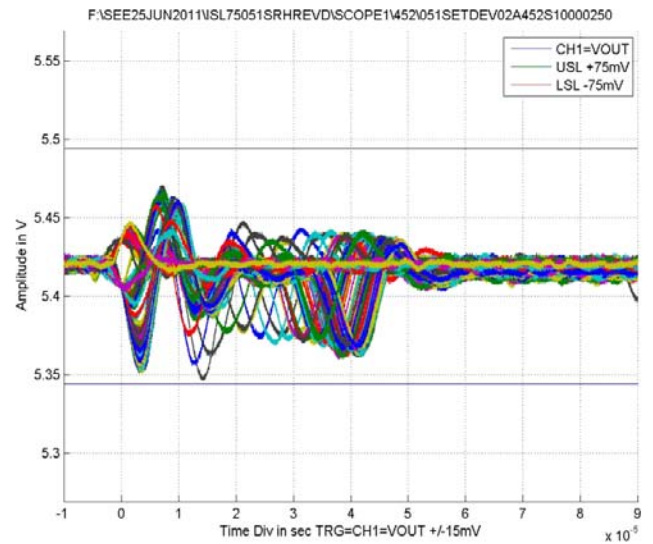
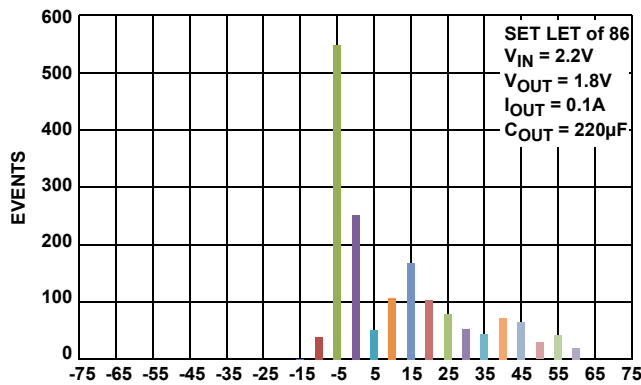

FIGURE 26. TYPICAL CAPTURE AT $V_{IN} = 6.0V$, RUN 452

NOTE:

- 10. The waveforms signature observed in Figures 19 through 26 is caused by the handoff between main and redundant references during an SET event. This does not affect normal operation of the device.

SET V_{OUT} Histogram Plots for ISL75051SRH (Note 11)



POSITIVE AND NEGATIVE OVERSHOOT IN mV
TOTAL EVENTS = 840, AREA OF CROSS SECTION = $1.05 \times 10^{-4} \text{cm}^2$

FIGURE 27. $V_{IN} = 2.2\text{V}$ at 0.1A

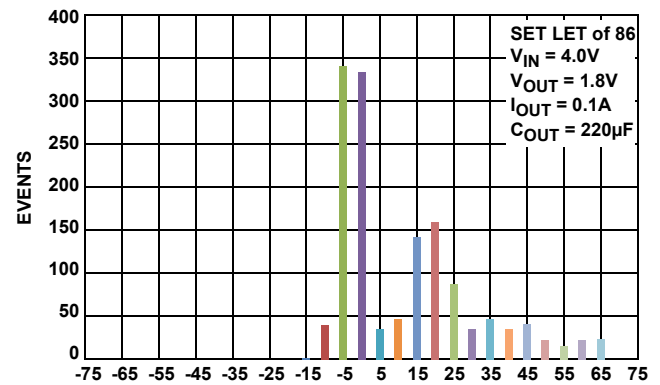

POSITIVE AND NEGATIVE OVERSHOOT IN mV
TOTAL EVENTS = 717, AREA OF CROSS SECTION = $0.89625 \times 10^{-4} \text{cm}^2$

FIGURE 28. $V_{IN} = 4.0\text{V}$ at 0.1A

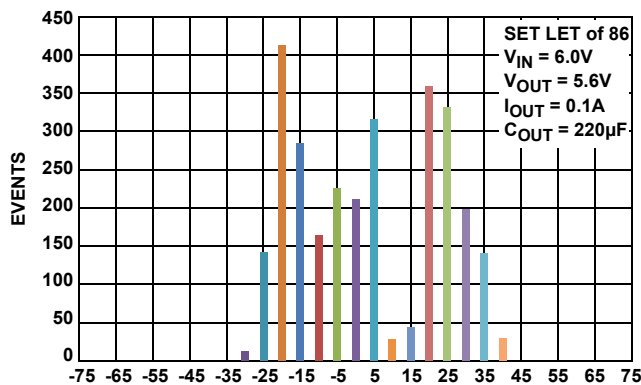

POSITIVE AND NEGATIVE OVERSHOOT IN mV
TOTAL EVENTS = 1448, AREA OF CROSS SECTION = $1.81 \times 10^{-4} \text{cm}^2$

FIGURE 29. $V_{IN} = 6.0\text{V}$ at 0.1A

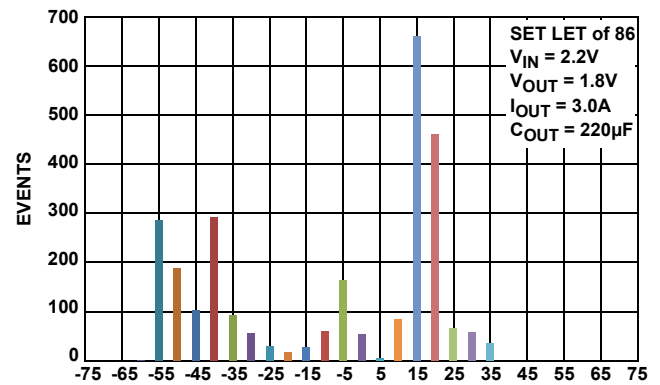

POSITIVE AND NEGATIVE OVERSHOOT IN mV
TOTAL EVENTS = 1372, AREA OF CROSS SECTION = $1.715 \times 10^{-4} \text{cm}^2$

FIGURE 30. $V_{IN} = 2.2\text{V}$ at 3.0A

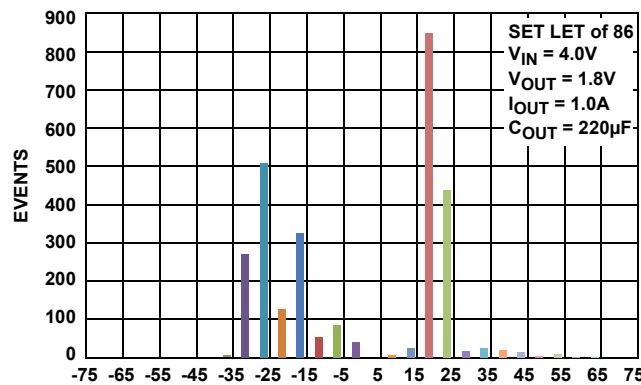

POSITIVE AND NEGATIVE OVERSHOOT IN mV
TOTAL EVENTS = 1411, AREA OF CROSS SECTION = $1.76375 \times 10^{-4} \text{cm}^2$

FIGURE 31. $V_{IN} = 4.0\text{V}$ at 1.0A

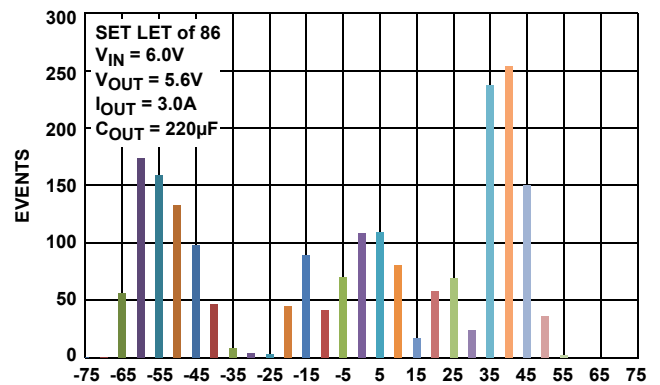

POSITIVE AND NEGATIVE OVERSHOOT IN mV
TOTAL EVENTS = 1037, AREA OF CROSS SECTION = $1.29625 \times 10^{-4} \text{cm}^2$

FIGURE 32. $V_{IN} = 6.0\text{V}$ at 3.0A

NOTE:

11. Oscilloscope set to trigger to V_{OUT} window of $\pm 15\text{mV}$ over the nominal V_{OUT} value. The two peaks represent positive and negative transients.

TABLE 5. DETAILS OF SEB/L TESTS

TEMP (°C)	LET (MeV.cm ² /mg)	BYP CAP (µF)	VDD (V)	LATCH EVENTS	CUMULATIVE FLUENCE (PARTICLES/cm ²)	CUMULATIVE CROSS SECTION (cm ²)	DEVICE	SEB/L
125	86	0.2	7.1	0	2.0 x 10 ⁺⁶	5.0 x 10 ⁻⁷	1	PASS
125	86	0.2	7.1	0	2.0 x 10 ⁺⁶	5.0 x 10 ⁻⁷	2	PASS
125	86	0.2	7.1	0	2.0 x 10 ⁺⁶	5.0 x 10 ⁻⁷	3	PASS
125	86	0.2	7.1	0	2.0 x 10 ⁺⁶	5.0 x 10 ⁻⁷	4	PASS
TOTAL EVENTS				0				
OVERALL FLUENCE					8.0 x 10 ⁺⁶			
OVERALL CROSS SECTION						1.25 x 10 ⁻⁷		
TOTAL UNITS							4	

Die Map and Mask Number

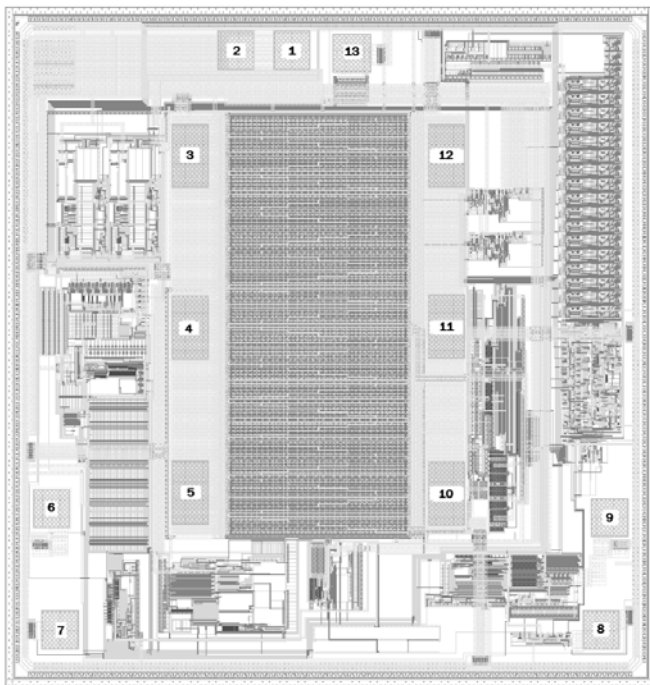

FIGURE 33. ISL75051SRH DIE MAP

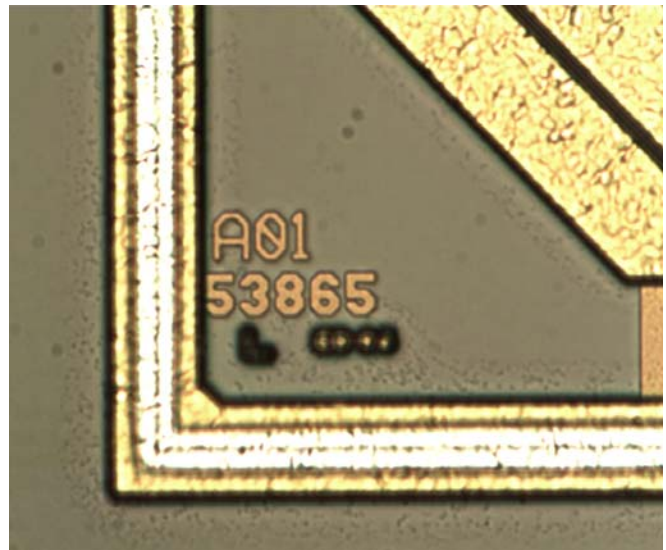

FIGURE 34. ISL75051SRH MASK NUMBER

Notice

1. Descriptions of circuits, software and other related information in this document are provided only to illustrate the operation of semiconductor products and application examples. You are fully responsible for the incorporation or any other use of the circuits, software, and information in the design of your product or system. Renesas Electronics disclaims any and all liability for any losses and damages incurred by you or third parties arising from the use of these circuits, software, or information.
2. Renesas Electronics hereby expressly disclaims any warranties against and liability for infringement or any other claims involving patents, copyrights, or other intellectual property rights of third parties, by or arising from the use of Renesas Electronics products or technical information described in this document, including but not limited to, the product data, drawings, charts, programs, algorithms, and application examples.
3. No license, express, implied or otherwise, is granted hereby under any patents, copyrights or other intellectual property rights of Renesas Electronics or others.
4. You shall not alter, modify, copy, or reverse engineer any Renesas Electronics product, whether in whole or in part. Renesas Electronics disclaims any and all liability for any losses or damages incurred by you or third parties arising from such alteration, modification, copying or reverse engineering.
5. Renesas Electronics products are classified according to the following two quality grades: "Standard" and "High Quality". The intended applications for each Renesas Electronics product depends on the product's quality grade, as indicated below.
"Standard": Computers; office equipment; communications equipment; test and measurement equipment; audio and visual equipment; home electronic appliances; machine tools; personal electronic equipment; industrial robots; etc.
"High Quality": Transportation equipment (automobiles, trains, ships, etc.); traffic control (traffic lights); large-scale communication equipment; key financial terminal systems; safety control equipment; etc.
Unless expressly designated as a high reliability product or a product for harsh environments in a Renesas Electronics data sheet or other Renesas Electronics document, Renesas Electronics products are not intended or authorized for use in products or systems that may pose a direct threat to human life or bodily injury (artificial life support devices or systems; surgical implantations; etc.), or may cause serious property damage (space system; undersea repeaters; nuclear power control systems; aircraft control systems; key plant systems; military equipment; etc.). Renesas Electronics disclaims any and all liability for any damages or losses incurred by you or any third parties arising from the use of any Renesas Electronics product that is inconsistent with any Renesas Electronics data sheet, user's manual or other Renesas Electronics document.
6. When using Renesas Electronics products, refer to the latest product information (data sheets, user's manuals, application notes, "General Notes for Handling and Using Semiconductor Devices" in the reliability handbook, etc.), and ensure that usage conditions are within the ranges specified by Renesas Electronics with respect to maximum ratings, operating power supply voltage range, heat dissipation characteristics, installation, etc. Renesas Electronics disclaims any and all liability for any malfunctions, failure or accident arising out of the use of Renesas Electronics products outside of such specified ranges.
7. Although Renesas Electronics endeavors to improve the quality and reliability of Renesas Electronics products, semiconductor products have specific characteristics, such as the occurrence of failure at a certain rate and malfunctions under certain use conditions. Unless designated as a high reliability product or a product for harsh environments in a Renesas Electronics data sheet or other Renesas Electronics document, Renesas Electronics products are not subject to radiation resistance design. You are responsible for implementing safety measures to guard against the possibility of bodily injury, injury or damage caused by fire, and/or danger to the public in the event of a failure or malfunction of Renesas Electronics products, such as safety design for hardware and software, including but not limited to redundancy, fire control and malfunction prevention, appropriate treatment for aging degradation or any other appropriate measures. Because the evaluation of microcomputer software alone is very difficult and impractical, you are responsible for evaluating the safety of the final products or systems manufactured by you.
8. Please contact a Renesas Electronics sales office for details as to environmental matters such as the environmental compatibility of each Renesas Electronics product. You are responsible for carefully and sufficiently investigating applicable laws and regulations that regulate the inclusion or use of controlled substances, including without limitation, the EU RoHS Directive, and using Renesas Electronics products in compliance with all these applicable laws and regulations. Renesas Electronics disclaims any and all liability for damages or losses occurring as a result of your noncompliance with applicable laws and regulations.
9. Renesas Electronics products and technologies shall not be used for or incorporated into any products or systems whose manufacture, use, or sale is prohibited under any applicable domestic or foreign laws or regulations. You shall comply with any applicable export control laws and regulations promulgated and administered by the governments of any countries asserting jurisdiction over the parties or transactions.
10. It is the responsibility of the buyer or distributor of Renesas Electronics products, or any other party who distributes, disposes of, or otherwise sells or transfers the product to a third party, to notify such third party in advance of the contents and conditions set forth in this document.
11. This document shall not be reprinted, reproduced or duplicated in any form, in whole or in part, without prior written consent of Renesas Electronics.
12. Please contact a Renesas Electronics sales office if you have any questions regarding the information contained in this document or Renesas Electronics products.
(Note 1) "Renesas Electronics" as used in this document means Renesas Electronics Corporation and also includes its directly or indirectly controlled subsidiaries.
(Note 2) "Renesas Electronics product(s)" means any product developed or manufactured by or for Renesas Electronics.

(Rev.4.0-1 November 2017)



SALES OFFICES

Renesas Electronics Corporation

<http://www.renesas.com>

Refer to "<http://www.renesas.com/>" for the latest and detailed information.

Renesas Electronics America Inc.
1001 Murphy Ranch Road, Milpitas, CA 95035, U.S.A.
Tel: +1-408-432-8888, Fax: +1-408-434-5351

Renesas Electronics Canada Limited
9251 Yonge Street, Suite 8309 Richmond Hill, Ontario Canada L4C 9T3
Tel: +1-905-237-2004

Renesas Electronics Europe Limited
Dukes Meadow, Millboard Road, Bourne End, Buckinghamshire, SL8 5FH, U.K
Tel: +44-1628-651-700, Fax: +44-1628-651-804

Renesas Electronics Europe GmbH
Arcadiastrasse 10, 40472 Düsseldorf, Germany
Tel: +49-211-6503-0, Fax: +49-211-6503-1327

Renesas Electronics (China) Co., Ltd.
Room 1709 Quantum Plaza, No.27 ZhichunLu, Haidian District, Beijing, 100191 P. R. China
Tel: +86-10-8235-1155, Fax: +86-10-8235-7679

Renesas Electronics (Shanghai) Co., Ltd.
Unit 301, Tower A, Central Towers, 555 Langao Road, Putuo District, Shanghai, 200333 P. R. China
Tel: +86-21-2226-0888, Fax: +86-21-2226-0999

Renesas Electronics Hong Kong Limited
Unit 1601-1611, 16/F., Tower 2, Grand Century Place, 193 Prince Edward Road West, Mongkok, Kowloon, Hong Kong
Tel: +852-2265-6688, Fax: +852-2886-9022

Renesas Electronics Taiwan Co., Ltd.
13F, No. 363, Fu Shing North Road, Taipei 10543, Taiwan
Tel: +886-2-8175-9600, Fax: +886-2-8175-9670

Renesas Electronics Singapore Pte. Ltd.
80 Bendemeer Road, Unit #06-02 Hyflux Innovation Centre, Singapore 339949
Tel: +65-6213-0200, Fax: +65-6213-0300

Renesas Electronics Malaysia Sdn.Bhd.
Unit 1207, Block B, Menara Amcorp, Amcorp Trade Centre, No. 18, Jln Persiaran Barat, 46050 Petaling Jaya, Selangor Darul Ehsan, Malaysia
Tel: +60-3-7955-9390, Fax: +60-3-7955-9510

Renesas Electronics India Pvt. Ltd.
No.777C, 100 Feet Road, HAL 2nd Stage, Indiranagar, Bangalore 560 038, India
Tel: +91-80-67208700, Fax: +91-80-67208777

Renesas Electronics Korea Co., Ltd.
17F, KAMCO Yangjae Tower, 262, Gangnam-daero, Gangnam-gu, Seoul, 06265 Korea
Tel: +82-2-558-3737, Fax: +82-2-558-5338