US082-SSC3240EVZ

Evaluation Board for High-End 24-Bit Sensor Signal Conditioner with Analog and Digital Output

Introduction

This document provides quick-start instructions for the US082-SSC3240EVZ board, including setting up and programming the board.

Important: To ensure correct setup of the US082-SSC3240EVZ board, complete the steps in the order listed in [Quick Start Procedure](#).

Contents

1. Board Information	2
1.1 Acquiring the Board	2
1.2 Board Contents.....	2
1.2.1 Hardware Requirements.....	3
1.2.2 Software Requirements	3
2. Calibration Procedure	3
3. Quick Start Procedure	4
3.1 Install e ² Studio.....	4
3.2 Kit Hardware Connection	4
3.2.1 Load Cell Base and Platform	6
4. Board Testing	7
4.1 Programming the Renesas Development Board	7
4.2 Using RTT Viewer.....	9
5. References and Support	11
6. Revision History	12

1. Board Information

1.1 Acquiring the Board

Visit the [US082-SSC3240EVZ](#) product page for more information about the board and how to acquire the product.

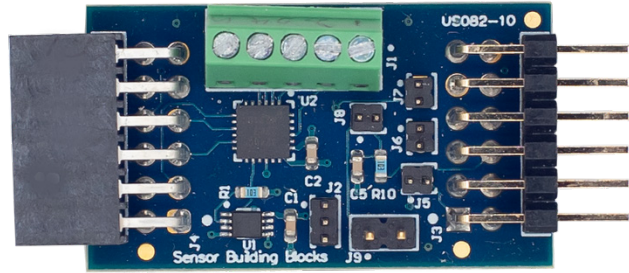

Figure 1. US082-SSC3240EVZ Board

Part Number	Description
US082-SSC3240EVZ	High-End 24-Bit Sensor Signal Conditioner with Analog and Digital Output

1.2 Board Contents

The US082-SSC3240EVZ board integrates the ZSSC3240, a high-precision sensor signal conditioning IC designed for amplification, digitization, and correction of resistive sensor signals including bridge, half-bridge, and single-element types like Pt100 and temperature diodes. The board offers 0V to 1V or 0V to 5V absolute voltage output and VDD-ratiometric voltage output. It also supports 4mA to 20mA current-loop output and 0V to 10V absolute-voltage output.

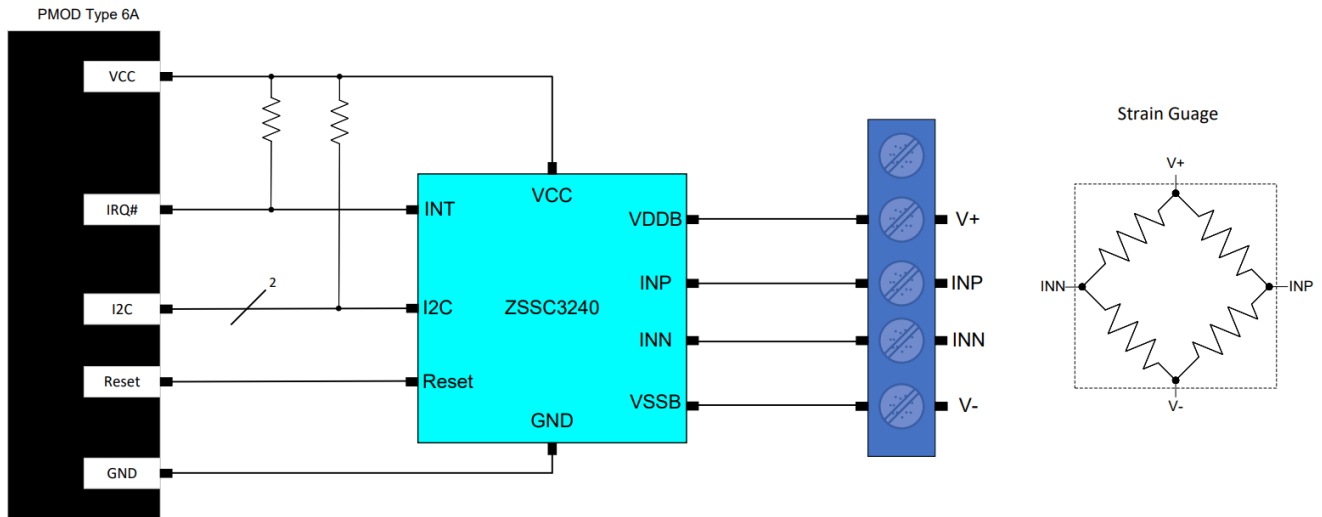

Figure 2. US082-SSC3240EVZ Block Diagram

1.2.1 Hardware Requirements

To setup and configure the US082-SSC3240EVZ board, the following hardware is recommended or required:

- EK-RA6M4
- USB micro-B cable (provided with the EK-RA6M4)
- PC running Windows 10/11 with at least one USB port
- Strain Gauge (1kg or greater)
- Strain Gauge platform
- Strain Gauge base
- Set of objects with known weights (for calibration)
- [SSC Communication Board](#) (for calibration)
- [US082-SSCALINTRPEVZ](#) (for calibration)
- [US082-INTERPEVZ](#)

1.2.2 Software Requirements

The following software is required or recommended:

- [e2 Studio](#) 2024-01 or later
 - [RA Flexible Software Package \(FSP\)](#) 5.0.0 or later
 - [GCC Arm Embedded](#) 13.2.1.arm-13-7
 - Sample code files (available on the [US082-SSC3240EVZ](#) product page)
- [J-Link RTT Viewer](#)
- ZSSC3240 Evaluation Software (available on the [ZSSC3240](#) product page)

2. Calibration Procedure

Follow the calibration procedure steps in the [ZSSC3240 Calibration Guide](#). For the best performance, use the load cell and known weights to calibrate the US082-SSC3240EVZ.

When calibrating the sensor, ensure the measured sensor range covers at least 70% of total sensor range.

Example calibration values used in this demo are listed below:

Sensor Coefficients	Value	Temperature Coefficients	Value
Offset_S	1100323	Gain_T	2097152
Gain_S	4029196	-	-
SOT_S	-303	-	-

3. Quick Start Procedure

Complete the following quick-start procedure steps in the order listed.

3.1 Install e² Studio

Install the latest version of the [e² Studio](#) and the [RA Flexible Software Package \(FSP\)](#).

3.2 Kit Hardware Connection

Use the following steps to set up the kit's hardware connections.

1. Ensure that the MCU development kit has at least one Type 6A Pmod.
 - a. For the EK-RA6M4, if no Type 6A Pmod is available, ensure that the kit can use the US082-INTERPEVZ interposer board. Insert the interposer into the MCU connector before adding any sensor boards.
2. Mount the J5, J6, and J7 jumpers on the US082-ZSSC3240EVZ.
3. Connect the strain-gauge wires as shown below. This demo uses a 1kg strain-gauge.

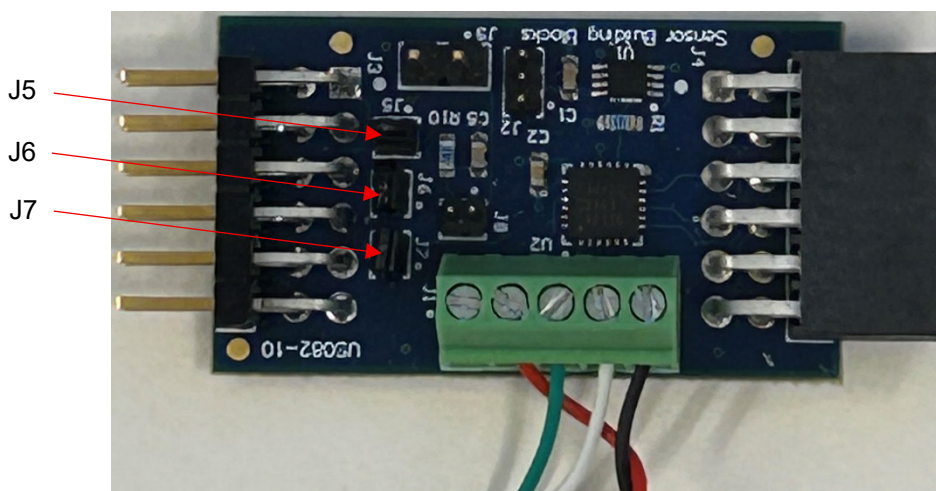

Figure 3. Strain Gauge Connection

Strain-Gauge	US082-ZSSC3240EVZ
E+ (Red)	VDDB
A+ (Green)	INP
A- (White)	INN
E- (Black)	VSSB

4. Plug the US082-SSC3240EVZ board into the US082-INTERPEVZ on the PMOD1 connector. Ensure all pins are properly aligned (see [Figure 4](#)).
5. Connect the EK-RA6M4 to the computer using the USB micro-B cable.

The kit is now ready to use.

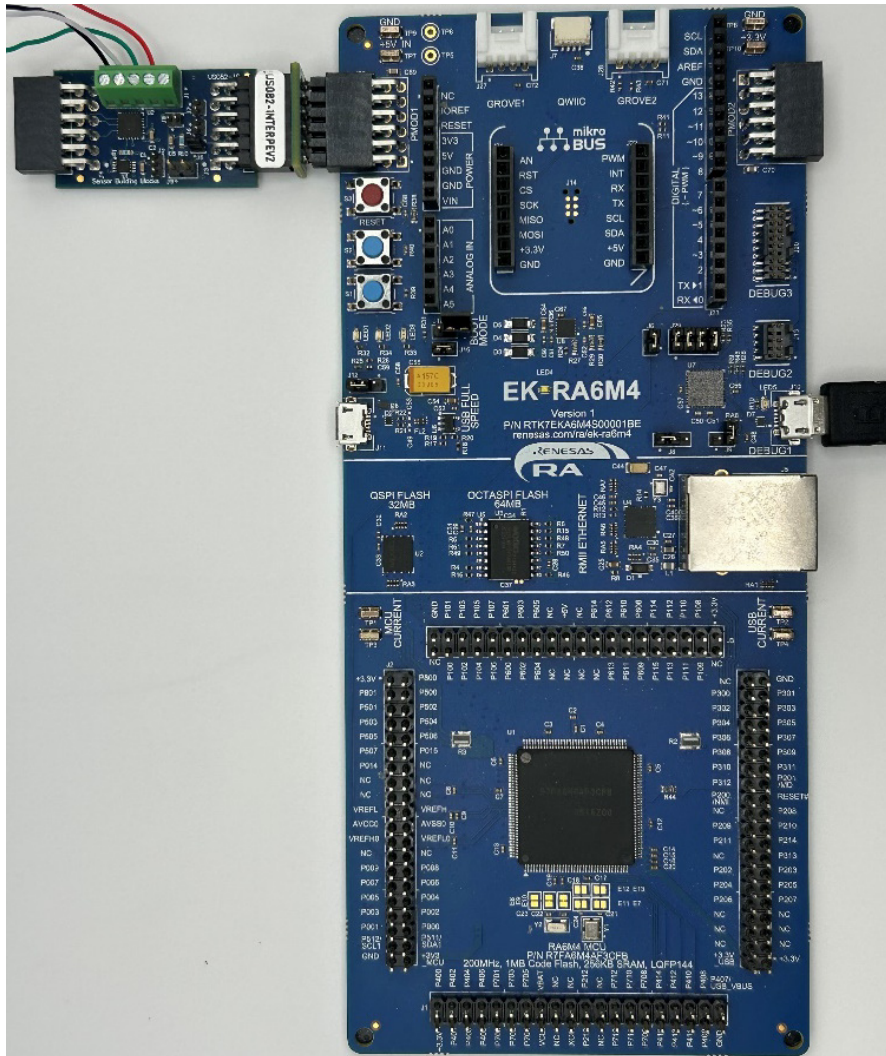

Figure 4. US082-SSC3240EVZ with EK-RA6M4 MCU Kit

3.2.1 Load Cell Base and Platform

If using the load cell base and platform, assemble the platform as follows:

1. Attach the load cell to the base using M5 screws (see [Figure 5](#)).

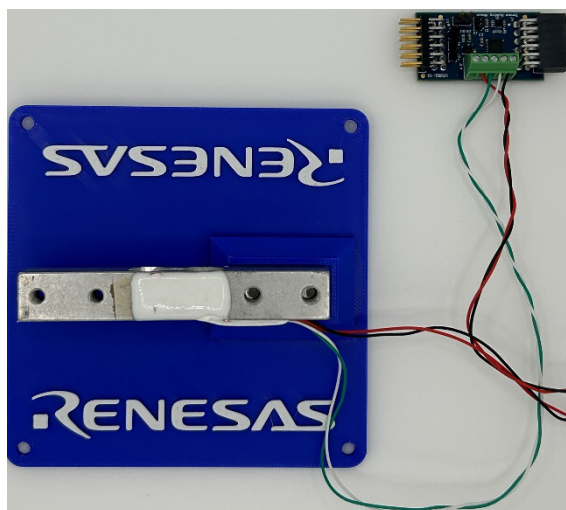

Figure 5. Load Cell Base

2. Next, attach the load cell to the scale platform using M4 screws, ensuring the arrow on the load cell is pointing down (see [Figure 6](#)).



Figure 6. Load Cell Platform

The load cell is now ready to use.

4. Board Testing

4.1 Programming the Renesas Development Board

1. Open the sample project in e² studio.

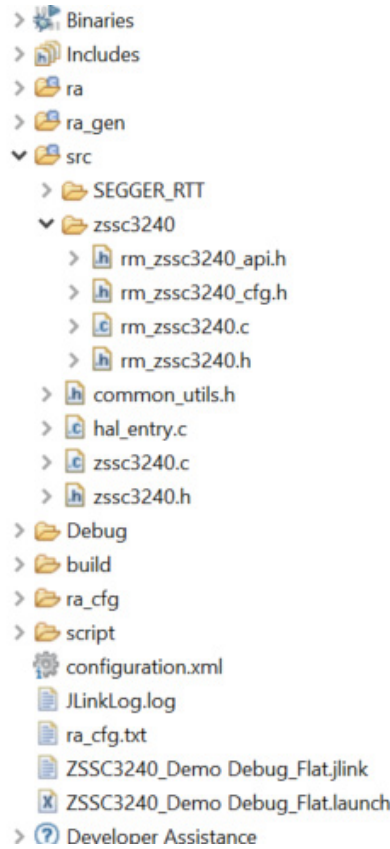

Figure 7. ZSSC3240 Project Structure

2. Click the Build icon.

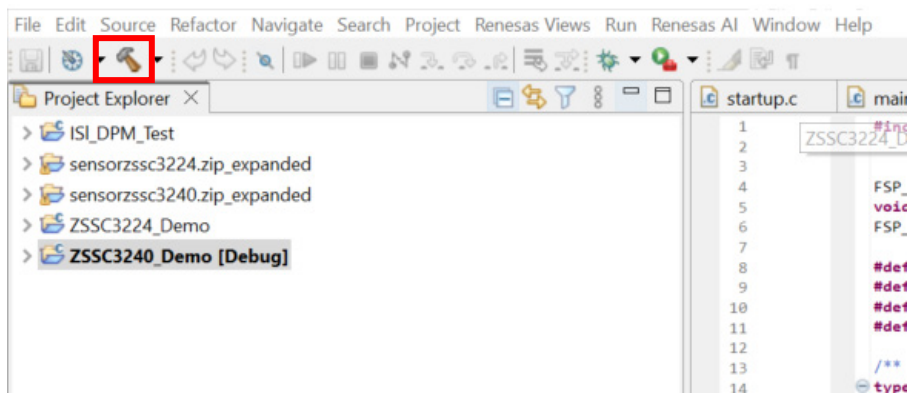

Figure 8. Project Build

3. From the menu bar, select **Run** → **Debug Configurations**.

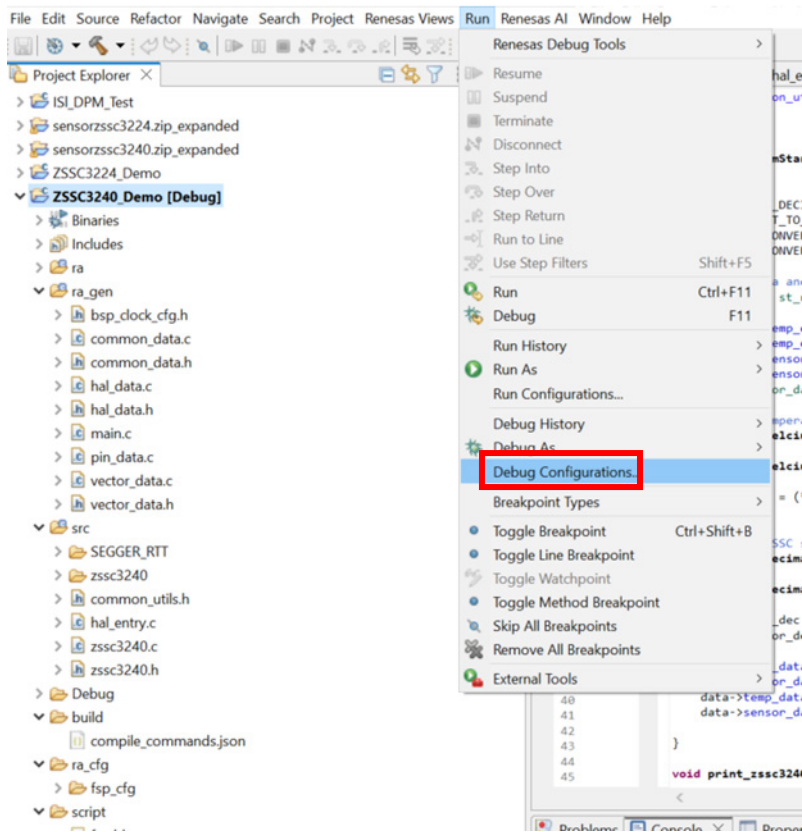

Figure 9. Debug Configuration

4. Select **Renesas GDB Hardware Debugging** → **ZSSC3240_Demo Debug_Flat** (see Figure 10).
5. Click the **Debug** button.

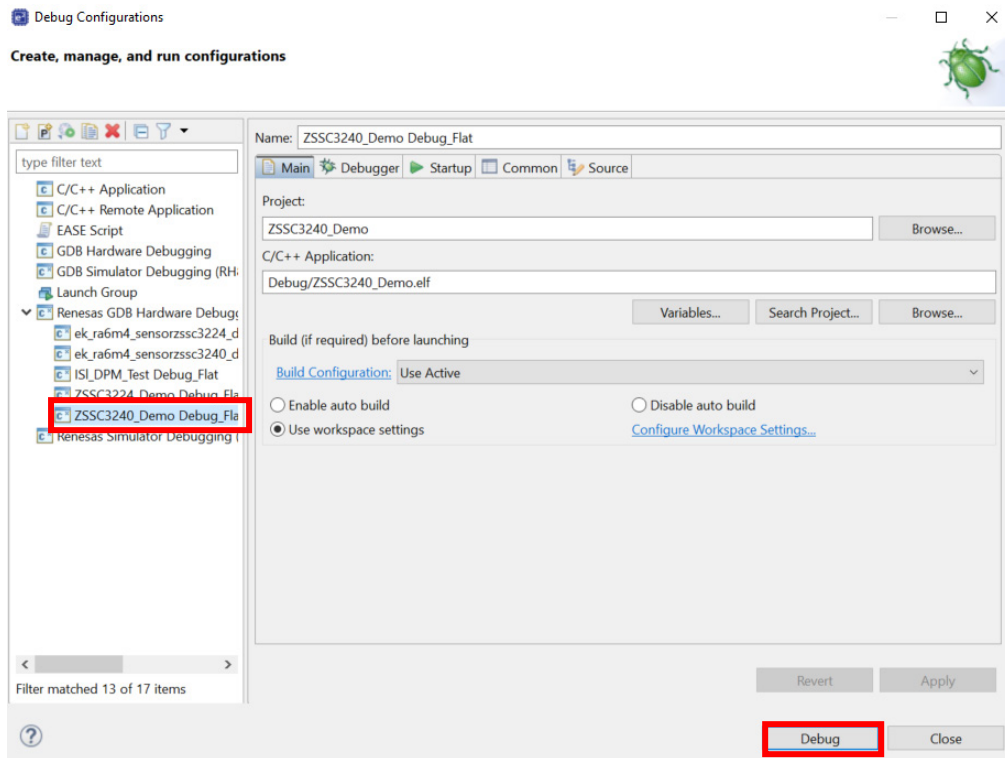

Figure 10. Start Debug Mode

- Click the **Play** button to run the code.

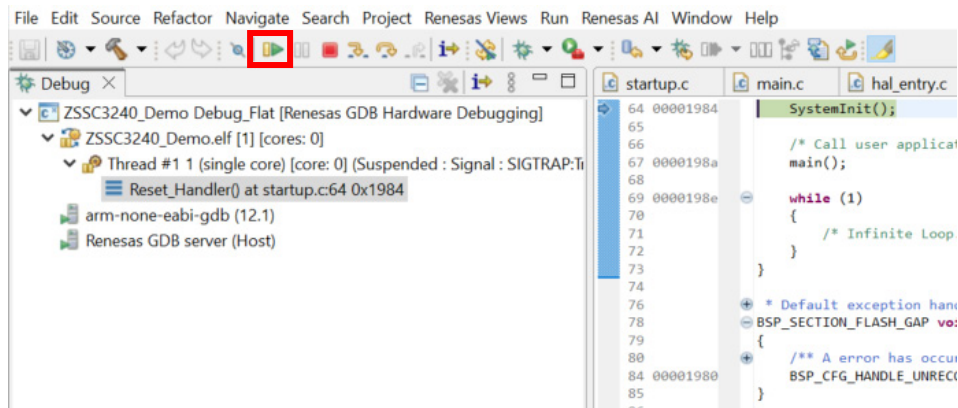

Figure 11. Running the Code

4.2 Using RTT Viewer

- Close e² studio.
- Open the J-Link RTT Viewer (see [Figure 12](#)).
- Press **S3** on the EK-RA6M4.
- Click **File** → **Connect**.

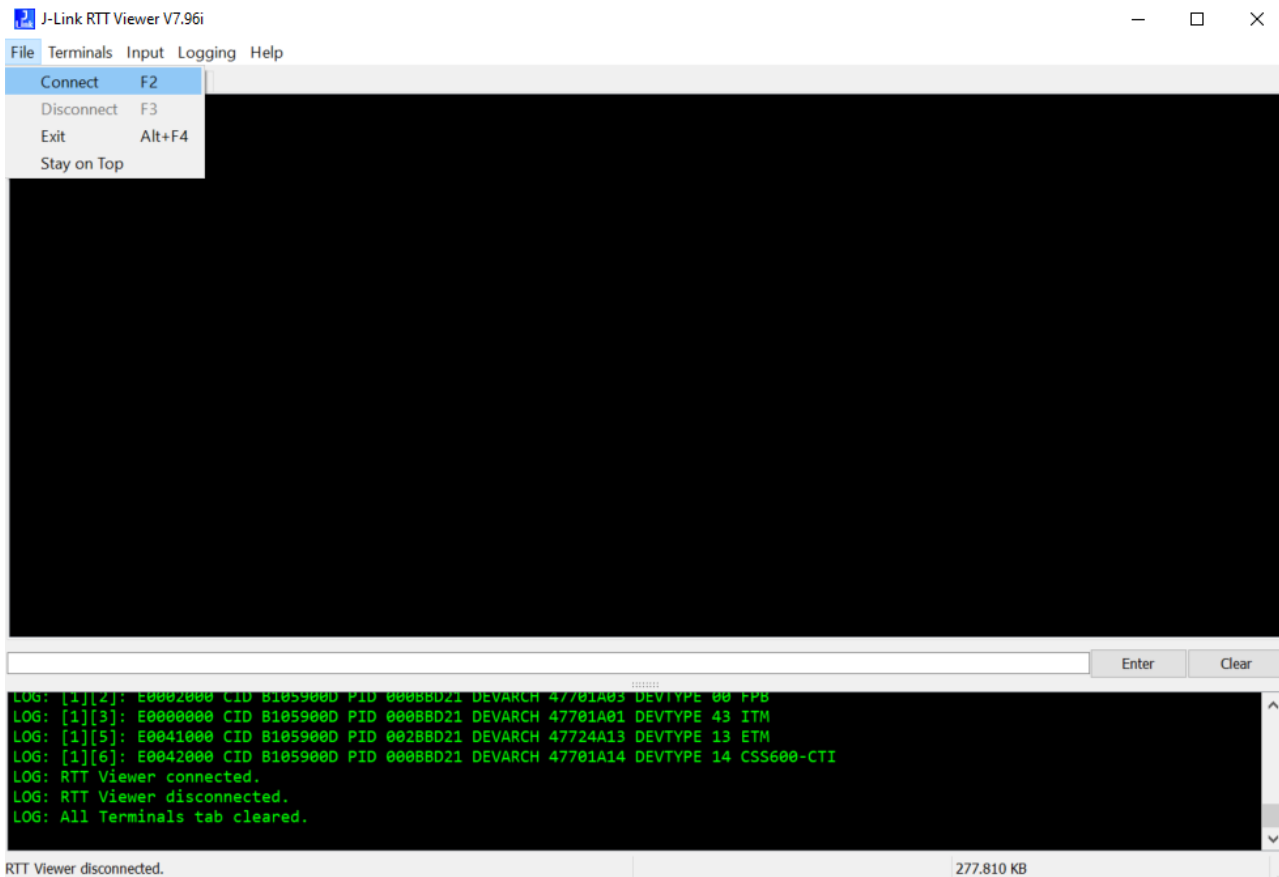

Figure 12. RTT Viewer

5. Ensure your configuration matches the configuration shown in [Figure 13](#).
 - a. Search Range: 0x20000000 0x8000
6. Click **OK**.

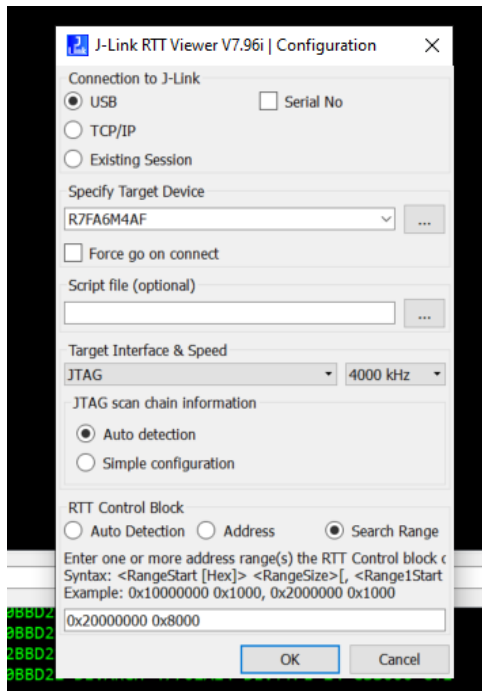

Figure 13. RTT Viewer Options

7. You should see the following output in the “All Terminals” tab.

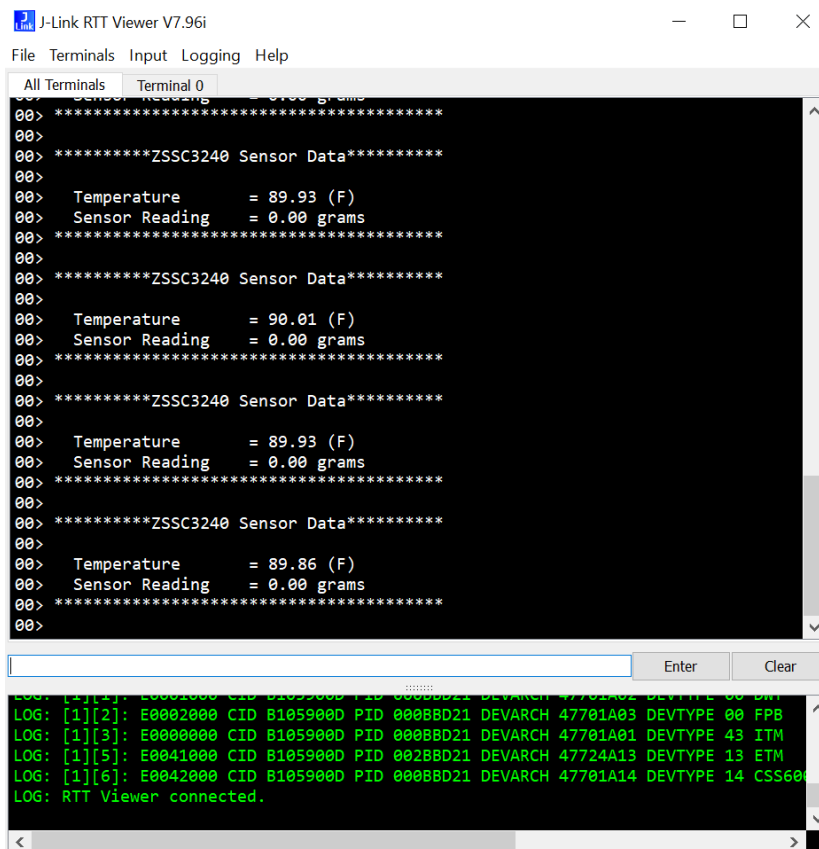

Figure 14. Demo Output

8. Add weight to the scale and the weight in grams is displayed in the terminal.

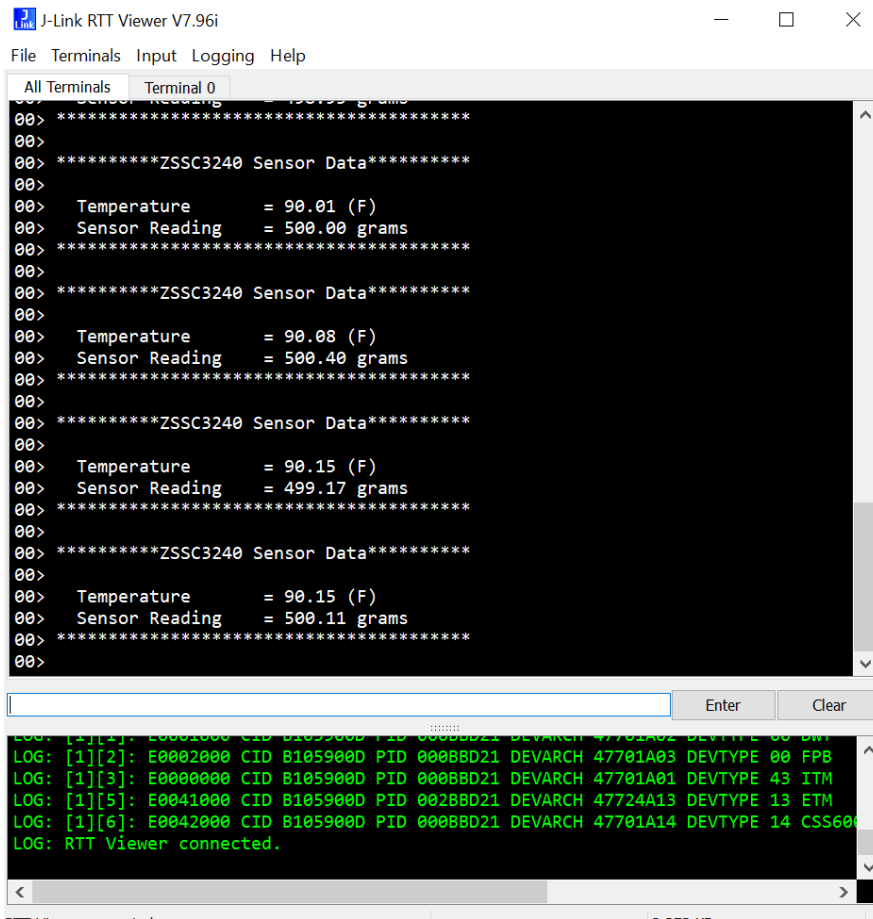

Figure 15. Sensor Output with 500g Weight

5. References and Support

- [e² studio](#) webpage
- [ZSSC3240](#) product page
- [RA Product Information](#)
- [RA Product Support Forum](#)
- [RA Flexible Software Package \(FSP\)](#)
- [Renesas Support](#)

6. Revision History

Revision	Date	Description
1.00	Jul 3, 2025	Initial release.

IMPORTANT NOTICE AND DISCLAIMER

RENESAS ELECTRONICS CORPORATION AND ITS SUBSIDIARIES (“RENESAS”) PROVIDES TECHNICAL SPECIFICATIONS AND RELIABILITY DATA (INCLUDING DATASHEETS), DESIGN RESOURCES (INCLUDING REFERENCE DESIGNS), APPLICATION OR OTHER DESIGN ADVICE, WEB TOOLS, SAFETY INFORMATION, AND OTHER RESOURCES “AS IS” AND WITH ALL FAULTS, AND DISCLAIMS ALL WARRANTIES, EXPRESS OR IMPLIED, INCLUDING, WITHOUT LIMITATION, ANY IMPLIED WARRANTIES OF MERCHANTABILITY, FITNESS FOR A PARTICULAR PURPOSE, OR NON-INFRINGEMENT OF THIRD-PARTY INTELLECTUAL PROPERTY RIGHTS.

These resources are intended for developers who are designing with Renesas products. You are solely responsible for (1) selecting the appropriate products for your application, (2) designing, validating, and testing your application, and (3) ensuring your application meets applicable standards, and any other safety, security, or other requirements. These resources are subject to change without notice. Renesas grants you permission to use these resources only to develop an application that uses Renesas products. Other reproduction or use of these resources is strictly prohibited. No license is granted to any other Renesas intellectual property or to any third-party intellectual property. Renesas disclaims responsibility for, and you will fully indemnify Renesas and its representatives against, any claims, damages, costs, losses, or liabilities arising from your use of these resources. Renesas' products are provided only subject to Renesas' Terms and Conditions of Sale or other applicable terms agreed to in writing. No use of any Renesas resources expands or otherwise alters any applicable warranties or warranty disclaimers for these products.

(Disclaimer Rev.1.01)

Corporate Headquarters

TOYOSU FORESIA, 3-2-24 Toyosu,
Koto-ku, Tokyo 135-0061, Japan
www.renesas.com

Trademarks

Renesas and the Renesas logo are trademarks of Renesas Electronics Corporation. All trademarks and registered trademarks are the property of their respective owners.

Contact Information

For further information on a product, technology, the most up-to-date version of a document, or your nearest sales office, please visit www.renesas.com/contact-us/.