

Power GreenPAK™ Development Motherboard

Development Board for Power GreenPAK™ Family Products

1. Install the Go Configure™ Software Hub

Download and install the latest Go Configure™ Software Hub from <https://www.renesas.com/software-tool/go-configure-software-hub>.

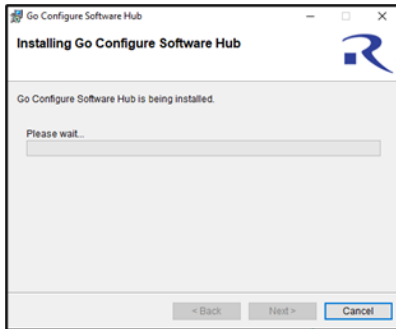

2. Create Your Project

Start the Go Configure™ Software Hub application and select the Power GreenPAK™ device which best suits your design. You are now ready to start development using all the available components including LDOs, LUTs, and much more.

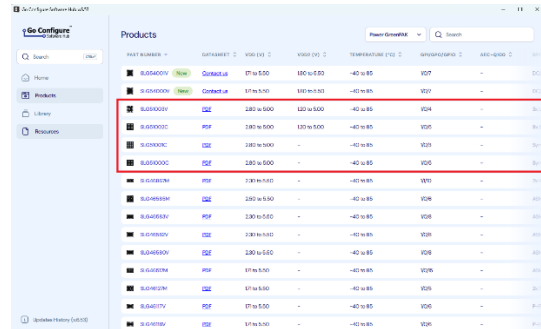

3. Prepare the Development Motherboard

Use the included AC/DC power adapter and use the USB-C cable to connect the Power GreenPAK™ Development Motherboard to your Windows, MacOS, or Linux based computer.

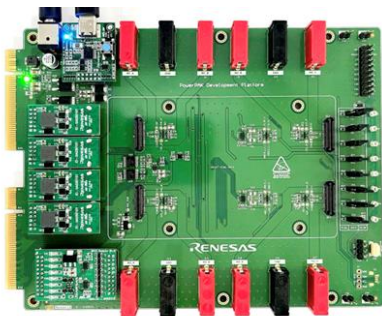

4. Insert the Evaluation Board

Connect the Power GreenPAK™ Evaluation Board you selected to the Power GreenPAK™ Development Motherboard.

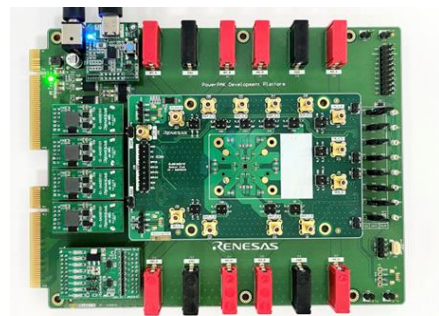

5. Using the Emulation Tool

Click the toolbar icon  to start the Power GreenPAK™ Emulation Tool. Choose the Power GreenPAK™ Development Motherboard. The schematic on the emulator control window represents the physical controls which are present on the Power GreenPAK™ Development Motherboard.

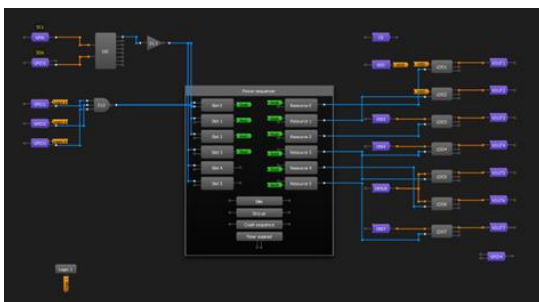

6. Emulate the Chip

Press the “Emulation” button to load your project code onto the device. At this time the device will operate according to the project code. Emulation can be performed multiple times, even on programmed chips. Press the “Emulation” button again to exit Emulation mode.

