

Product Change Notice (PCN)

Subject: Assembly factory change for Shunt Regulator power supply IC

Publication Date: 2/13/2023

Effective Date: 7/3/2023

Revision Description:

Initial Release

Description of Change:

Assembly factory will be changed for Shunt Regulator power supply IC.

<Production site>

	Production site
Before the change	Yamagata Electronic Corporation (Japan)
After the change	HCA : HIGH COMPONENTS AOMORI CO.,LTD. (Japan)

<Part number>

The die bonding material for 3p PoMM will be changed from solder paste to Ag paste.

The exterior plating of 5p MM will be changed from Sn to Sn-Bi.

Due to the above material change, Part number will be changed (product list No. 1 to No. 11)

In addition, since HCA does not have facilities for packaging tube products, tape products will be used as substitutes (product list No. 12 to No. 15).

<Form>

3p PoMM: Changed outline drawing. No change in dimensions (partial change in notation method)

5p MM: Changed outline drawing. Some dimensions have changed (some notation methods have changed)

5p MM dimension changes are as follows.

Item	Before the change	After the change
Body width	2.9mm	2.95mm
Body vertical width [terminal direction]	1.5mm	1.6mm
Terminal width	0.32mm	0.4mm

<Packaging specifications>

The following tube specifications (4 Part numbers below) before the change will be changed to tape specifications after the change.

UPC1093T-AZ

UPC1093TA-AT

UPC1943T-AZ

UPC1944T-AZ

Affected Product List:

No	Part number before change	Part number after change
1	UPC1093T-E1-AZ	UPC1093T-E1-A
2	UPC1093T-E2-AZ	UPC1093T-E2-A
3	UPC1093T-1-E1-AZ	UPC1093T-1-E1-A
4	UPC1093T-1-E2-AZ	UPC1093T-1-E2-A
5	UPC1943T-E1-AZ	UPC1943T-E1-A
6	UPC1943T-E2-AZ	UPC1943T-E2-A
7	UPC1944T-E1-AZ	UPC1944T-E1-A
8	UPC1944T-E2-AZ	UPC1944T-E2-A
9	UPC1093TA-E1-AT	UPC1093TA-E1-A
10	UPC1093TA-E2-AT	UPC1093TA-E2-A
11	UPC1093TA-1-E1-AT	UPC1093TA-1-E1-A
12	UPC1093T-AZ	UPC1093T-E1-A
13	UPC1093TA-AT	UPC1093TA-E1-A
14	UPC1943T-AZ	UPC1943T-E1-A
15	UPC1944T-AZ	UPC1944T-E1-A

Reason for Change:

Yamagata Electronics Corporation, which is currently producing the product, will not be able to continue production in the medium to long term due to the aging of the equipment for the target product, and plans to make final production adjustments in December 2023.

Therefore, we will transfer the post-process to HCA, so please consider it.

Impact on Fit, Form, Function, Quality & Reliability:

<Form>

3p PoMM: Changed outline drawing. No change in dimensions (partial change in notation method)

Before the changes

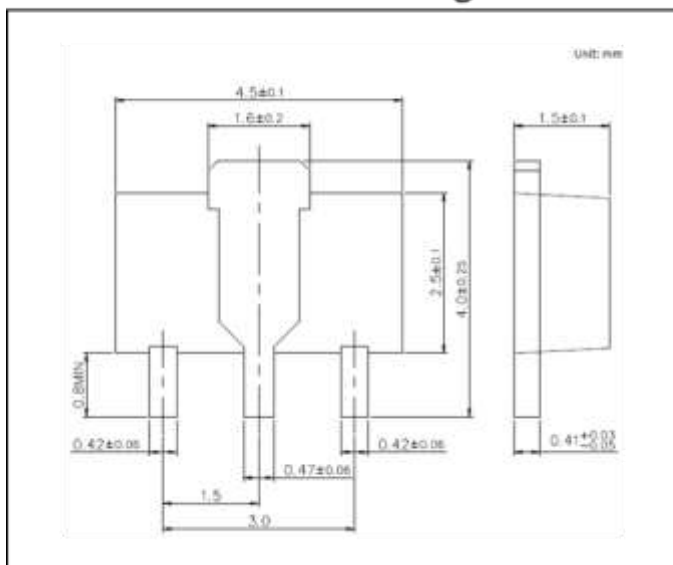

After the changes

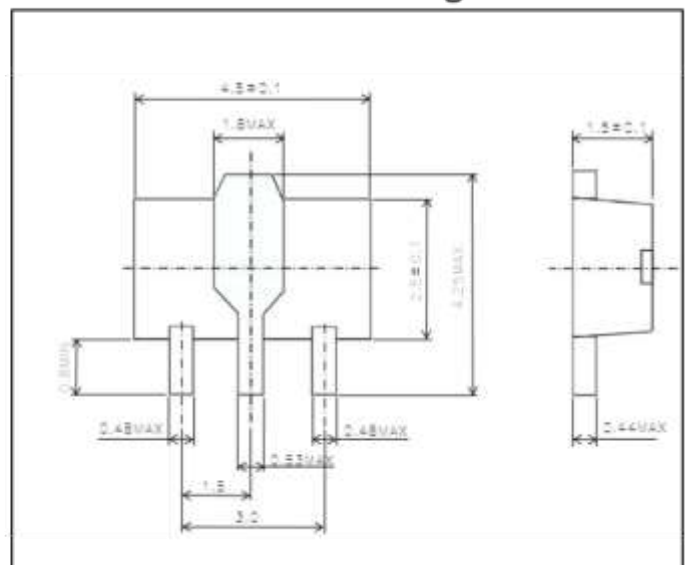

5p MM: Changed outline drawing. Some dimensions have changed (some notation methods have changed)

Before the changes

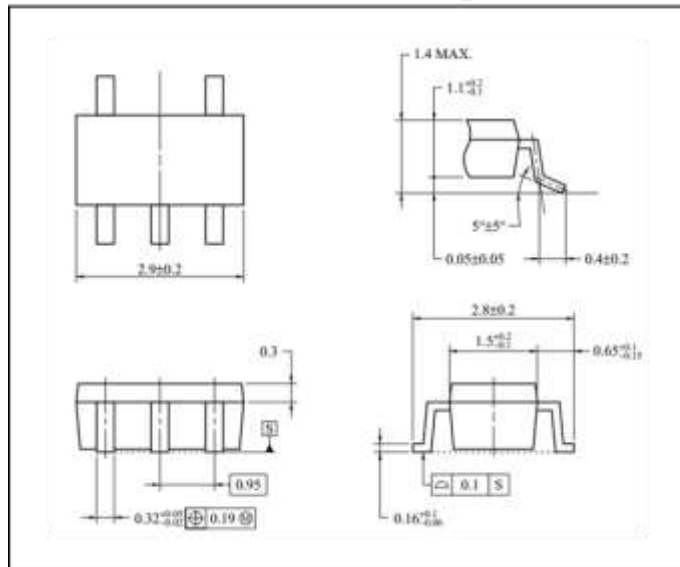

After the changes

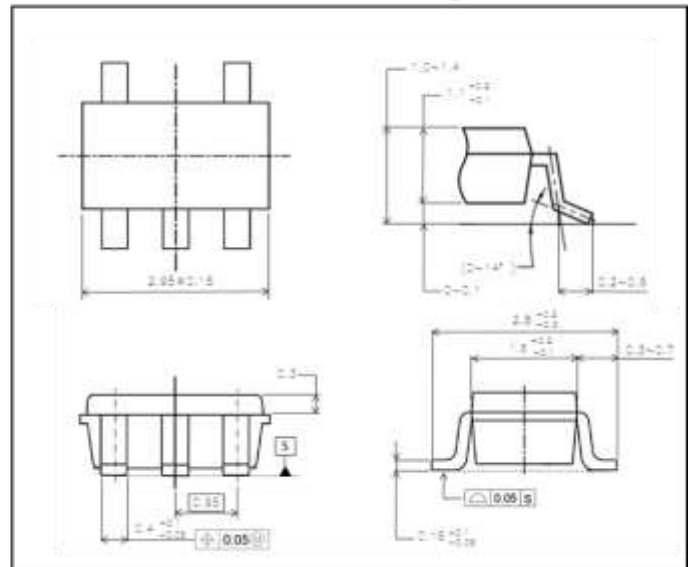

Product Identification:

< 3p PoMM >

Before the changes

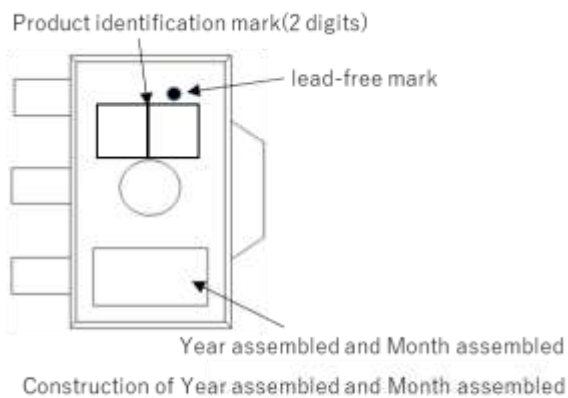

Construction of Year assembled and Month assembled



After the changes

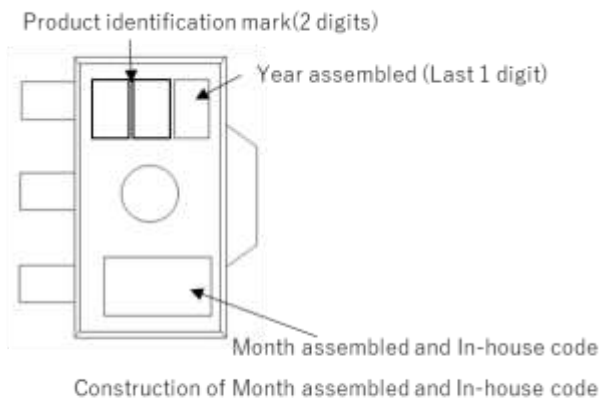

Construction of Month assembled and In-house code

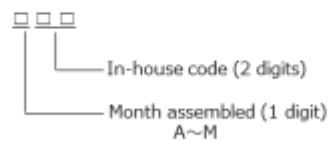

Part number	Product identification mark(2 digits)
UPC1093T	93
UPC1093T-1	7A
UPC1943T	9B
UPC1944T	9C

Before the changes

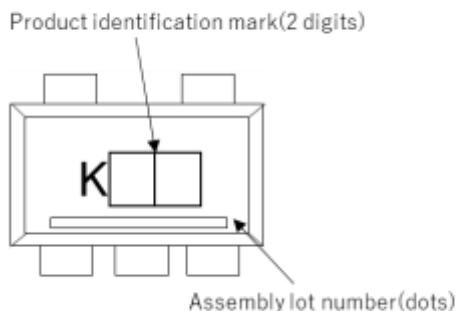

Construction of lot number

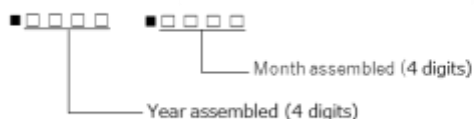

After the changes

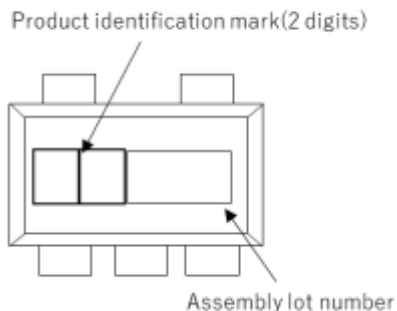

Construction of lot number

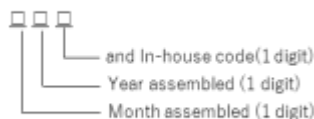

Part number	Product identification mark(2 digits)
UPC1093TA	93
UPC1093TA-1	91

Qualification Status: Available from 3/1/2023.

Sample Availability Date: 3/1/2023

Device Material Declaration: Available upon request

Note:

1. Acknowledgement must be received by Renesas within 30 days or Renesas will consider the change as approved.
2. If timely acknowledgement is provided by Customer, then Customer shall have 90 days from the date of receipt of this PCN to make any objections to this PCN. If Customer fails to make objections to this PCN within 90 days of the receipt of the PCN then Renesas will consider the PCN changes as approved.
3. If customer cannot accept the PCN then customer must provide Renesas with a last time buy demand and purchase order.

For additional information regarding this notice, please contact your Renesas sales representative.