

**EXAMPLE OF CAPACITOR
PLACEMENT
RH850/U2C4, U2C2 HLQFP100**

r01an7901jj0100-rh850u2c

CONTENTS

| | |
|---|-------------------|
| 1. Decoupling capacitors | 3 |
| 2. Example of capacitor placement | 4 |
| 2.1 U2C4 DPS HLQFP100 | 4 |
| 2.2 U2C4 eVR HLQFP100 (VCC=3.3V), U2C2 HLQFP100 | 5 |
| 2.3 U2C4 eVR HLQFP100 (VCC=5V) | 6 |
| 3. PCB layout guidelines -Top layer / Bottom layer- | 7 |
| 3.1 Example capacitor placement for U2C4 DPS HLQFP100 package | 7 |
| 3.2 Example capacitor placement for U2C4 eVR HLQFP100 package on VCC=3.3V condition and U2C2 HLQFP100 package | 8 |
| 3.3 Example capacitor placement for U2C4 eVR HLQFP100 package on VCC=5V condition | 9 |

1. DECOUPLING CAPACITORS

- Capacitor placement and number of capacitors: Please refer page 3 to 4.
 - Capacitors has been kept as close as feasible to the related supply pin.

- Types of capacitors:
 - 0.1uF, 0.22uF, 10uF or higher*1 ceramic capacitor (Low ESR/ESL is required)
 - *1: This is expected value. Please follow the Power IC specification.
 - 10uF 3-terminal ceramic capacitor (Very low ESR/ESL is required)

- 3-terminal capacitor
 - 3-terminal capacitor is recommended for reduction of radiation noise.

2. EXAMPLE OF CAPACITOR PLACEMENT

2.1 U2C4 DPS HLQFP100

Example capacitor connection for U2C4 DPS HLQFP100 package.

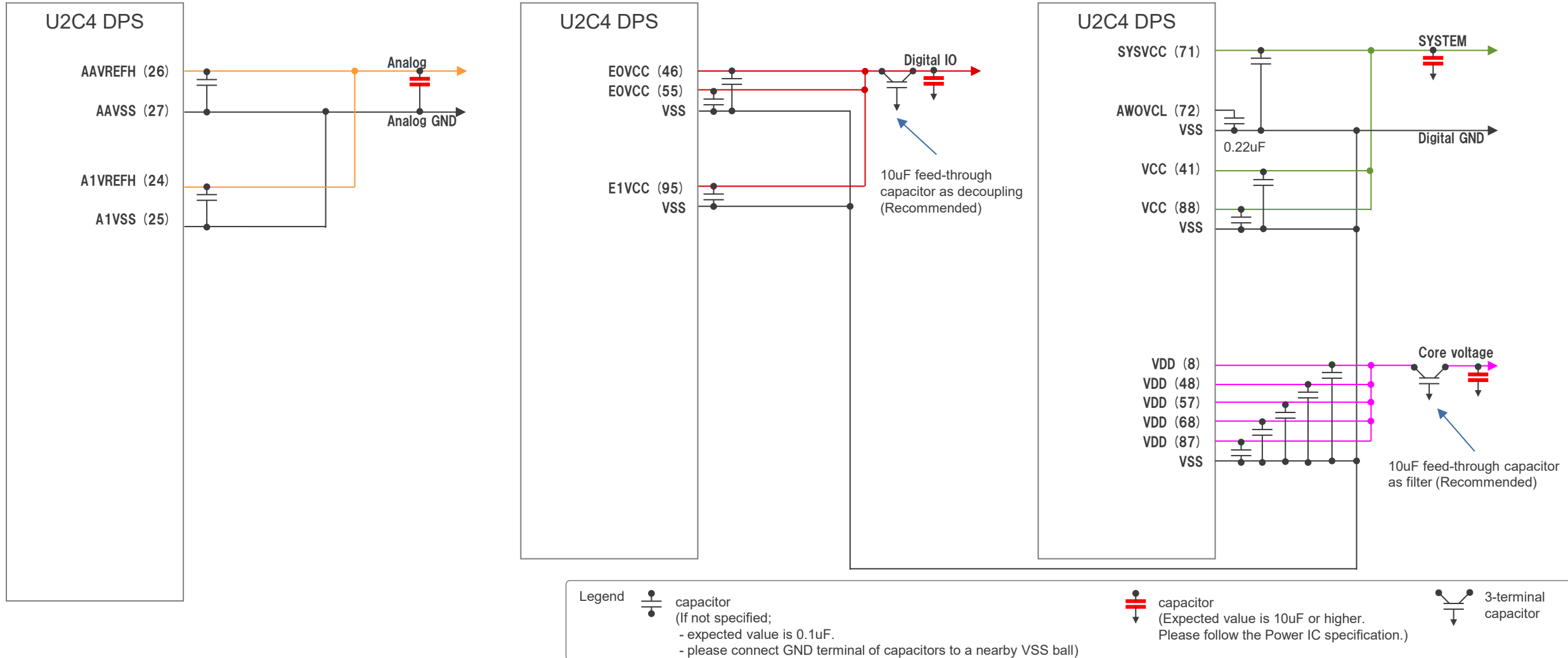

2. EXAMPLE OF CAPACITOR PLACEMENT

2.2 U2C4 EVR HLQFP100 (VCC=3.3V), U2C2 HLQFP100

Example capacitor connection for U2C4 eVR HLQFP100 package on VCC=3.3V condition and U2C2 HLQFP100 package.

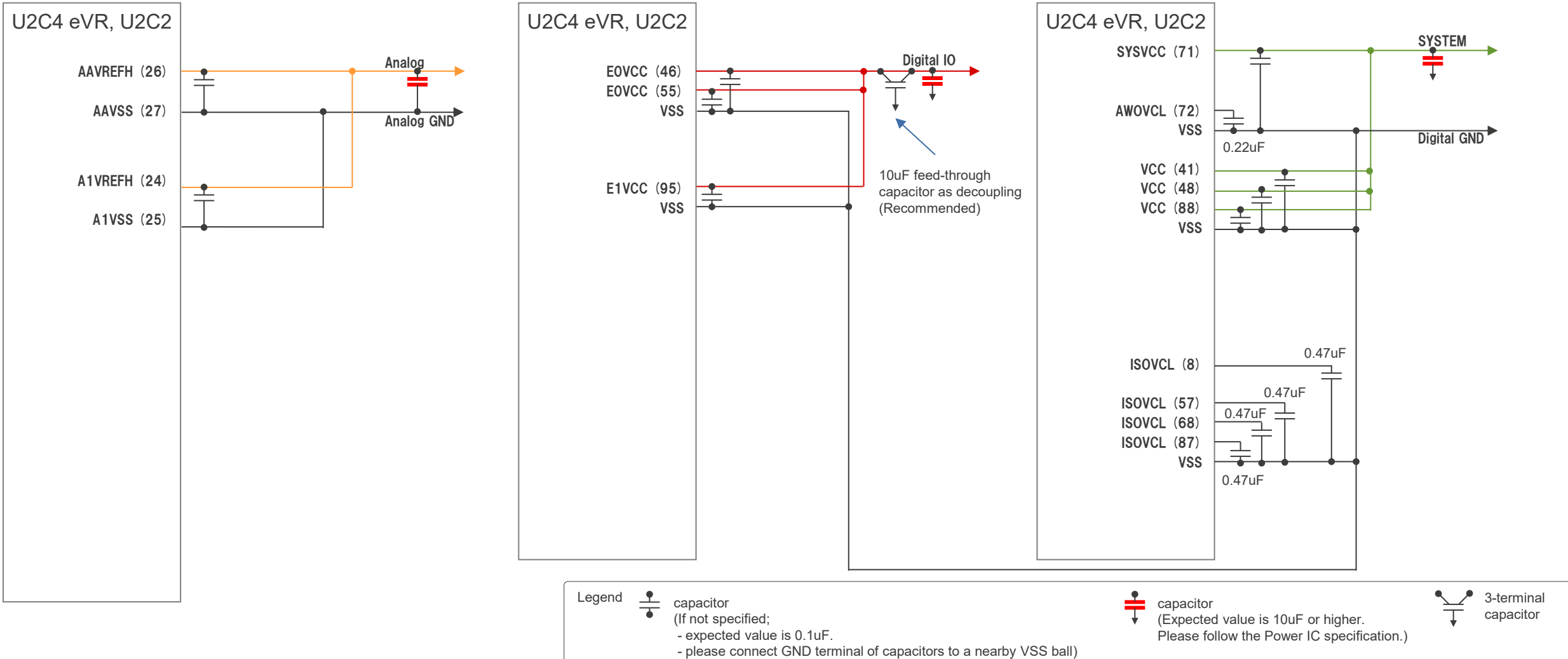

2. EXAMPLE OF CAPACITOR PLACEMENT

2.3 U2C4 EVR HLQFP100 (VCC=5V)

Example capacitor connection for U2C4 eVR HLQFP100 package on VCC=5V condition.

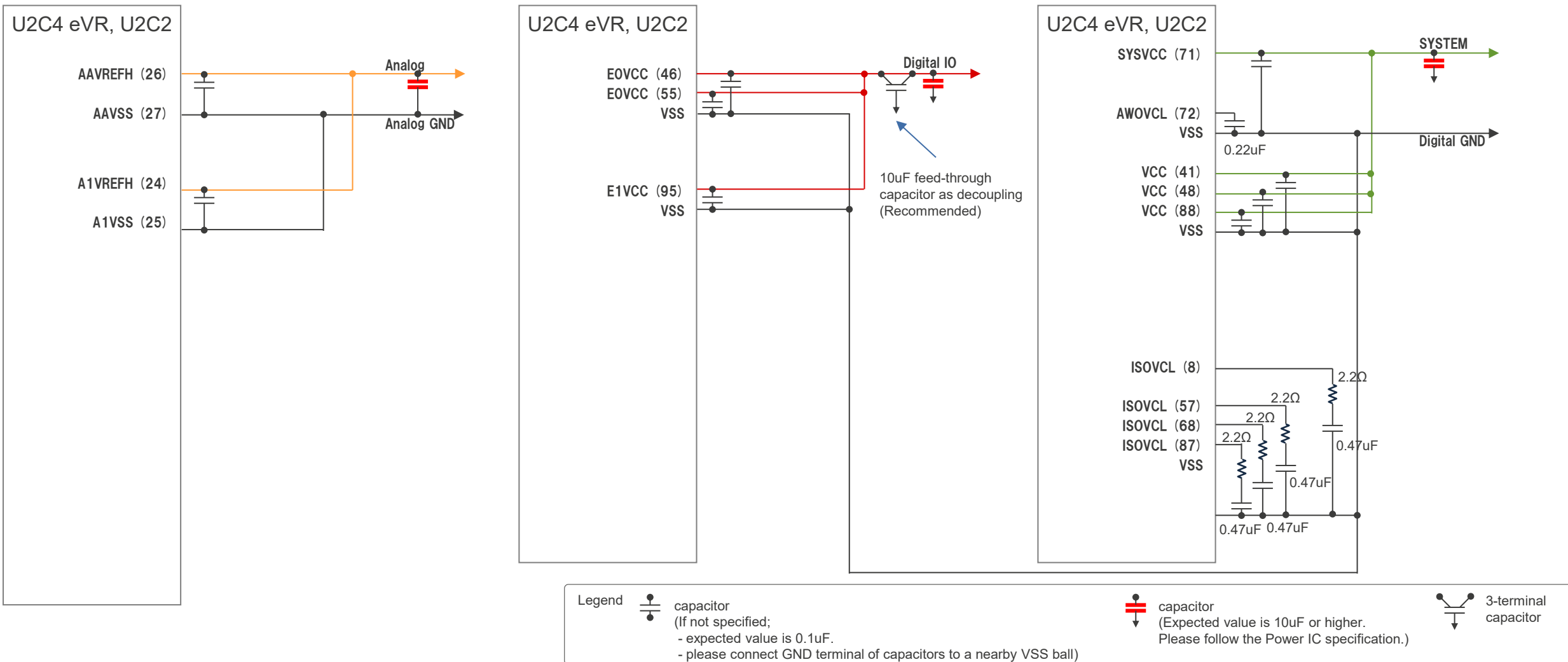

3. PCB LAYOUT GUIDELINES -TOP LAYER / BOTTOM LAYER-

3.1 Example capacitor placement for U2C4 DPS HLQFP100 package

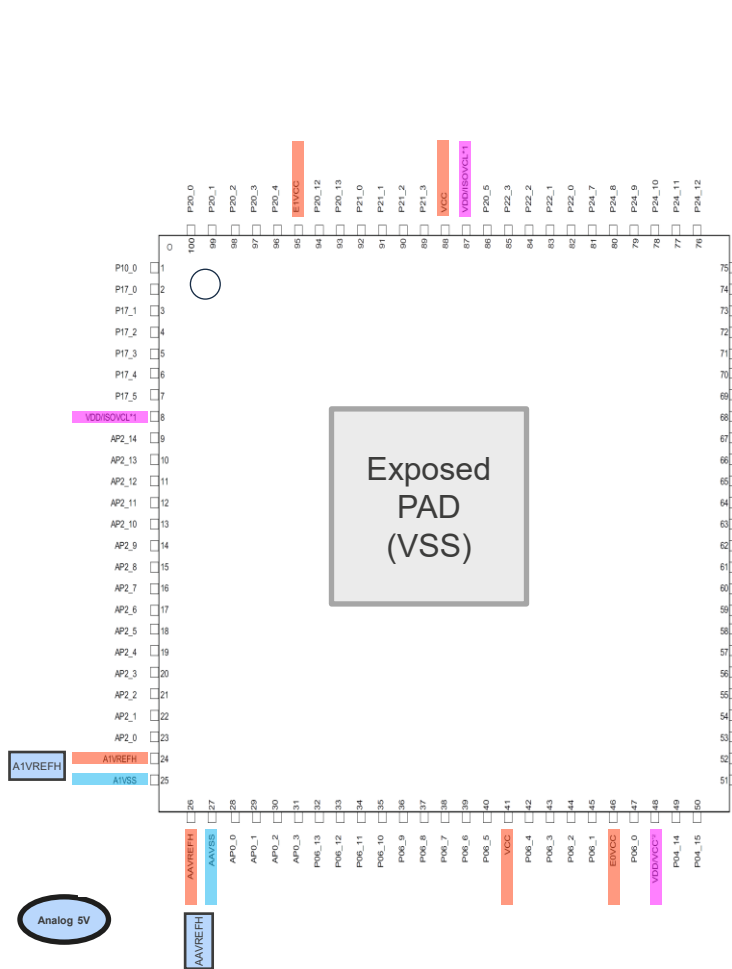



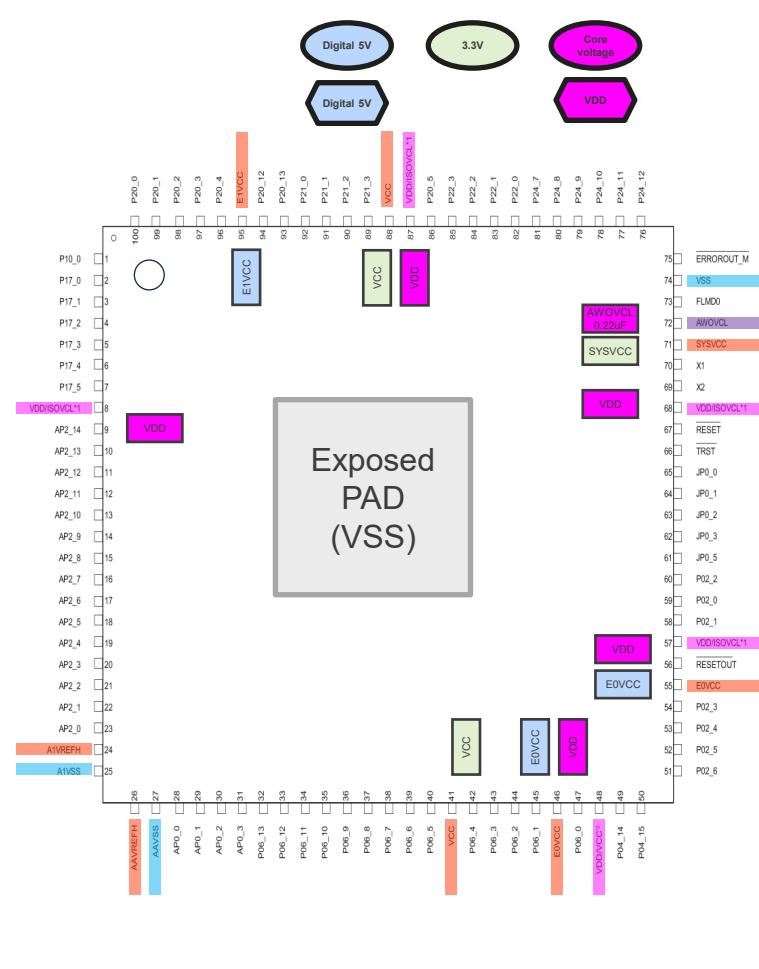





Top Layer



Bottom Layer

Legend

-  capacitor (analog, Digital IO)
(The capacitance is 0.1uF if not specified.)
-  capacitor (system)
(The capacitance is 0.1uF if not specified.)
-  capacitor (Core voltage)
(The capacitance is 0.1uF if not specified.)
-  capacitor (analog, Digital IO)
(Expected value is 10uF or higher. Please follow the Power IC specification.)
-  capacitor (system)
(Expected value is 10uF or higher. Please follow the Power IC specification.)
-  capacitor (Core voltage)
(Expected value is 10uF or higher. Please follow the Power IC specification.)
-  3-terminal capacitor (analog, Digital IO)
-  3-terminal capacitor (Core voltage)

3. PCB LAYOUT GUIDELINES -TOP LAYER / BOTTOM LAYER-

3.2 Example capacitor placement for U2C4 eVR HLQFP100 package on VCC=3.3V condition and U2C2 HLQFP100 package.

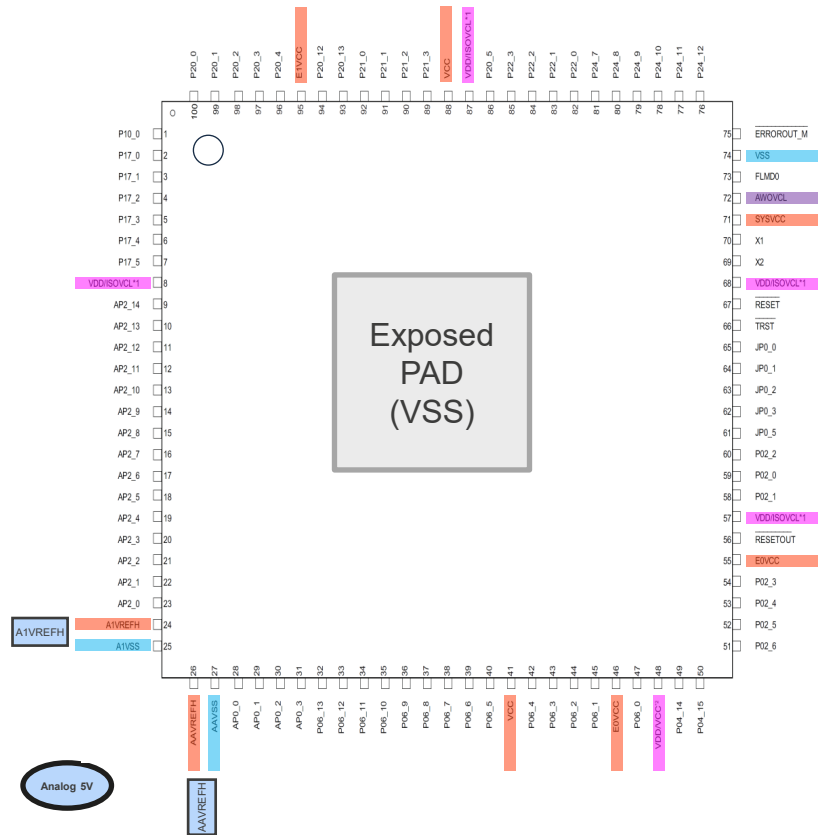



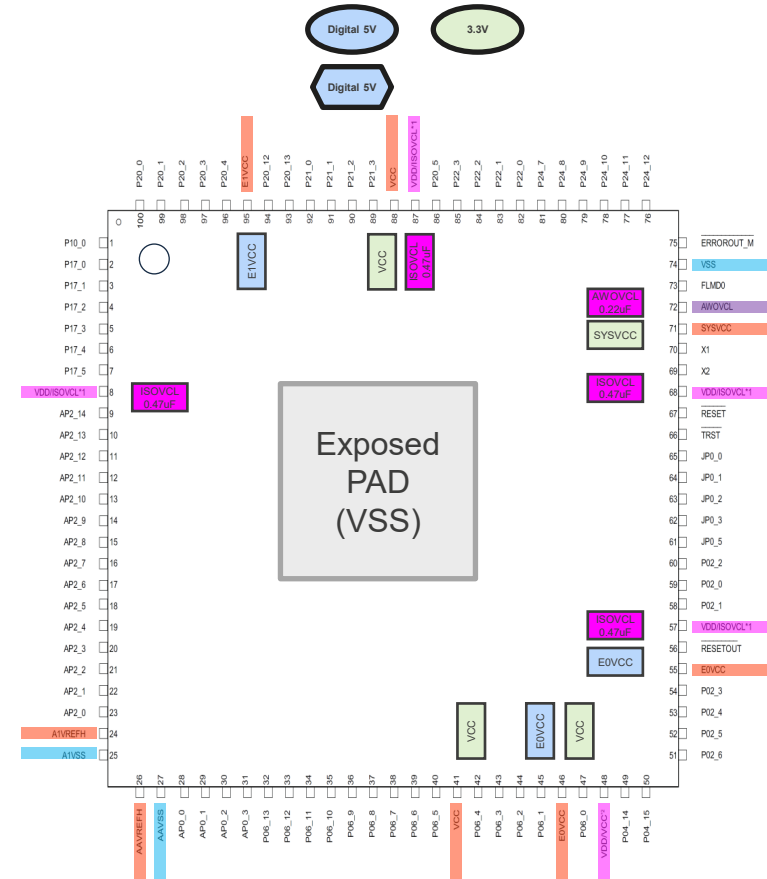





Top Layer



Bottom Layer

Legend

-  capacitor (analog, Digital IO)
(The capacitance is 0.1uF if not specified.)
-  capacitor (system)
(The capacitance is 0.1uF if not specified.)
-  capacitor (Core voltage)
(The capacitance is 0.1uF if not specified.)
-  capacitor (analog, Digital IO)
(Expected value is 10uF or higher. Please follow the Power IC specification.)
-  capacitor (system)
(Expected value is 10uF or higher. Please follow the Power IC specification.)
-  capacitor (Core voltage)
(Expected value is 10uF or higher. Please follow the Power IC specification.)
-  3-terminal capacitor (analog, Digital IO)
-  3-terminal capacitor (Core voltage)

U2C4 DPS QFP100 パソコン及びVIA配置例

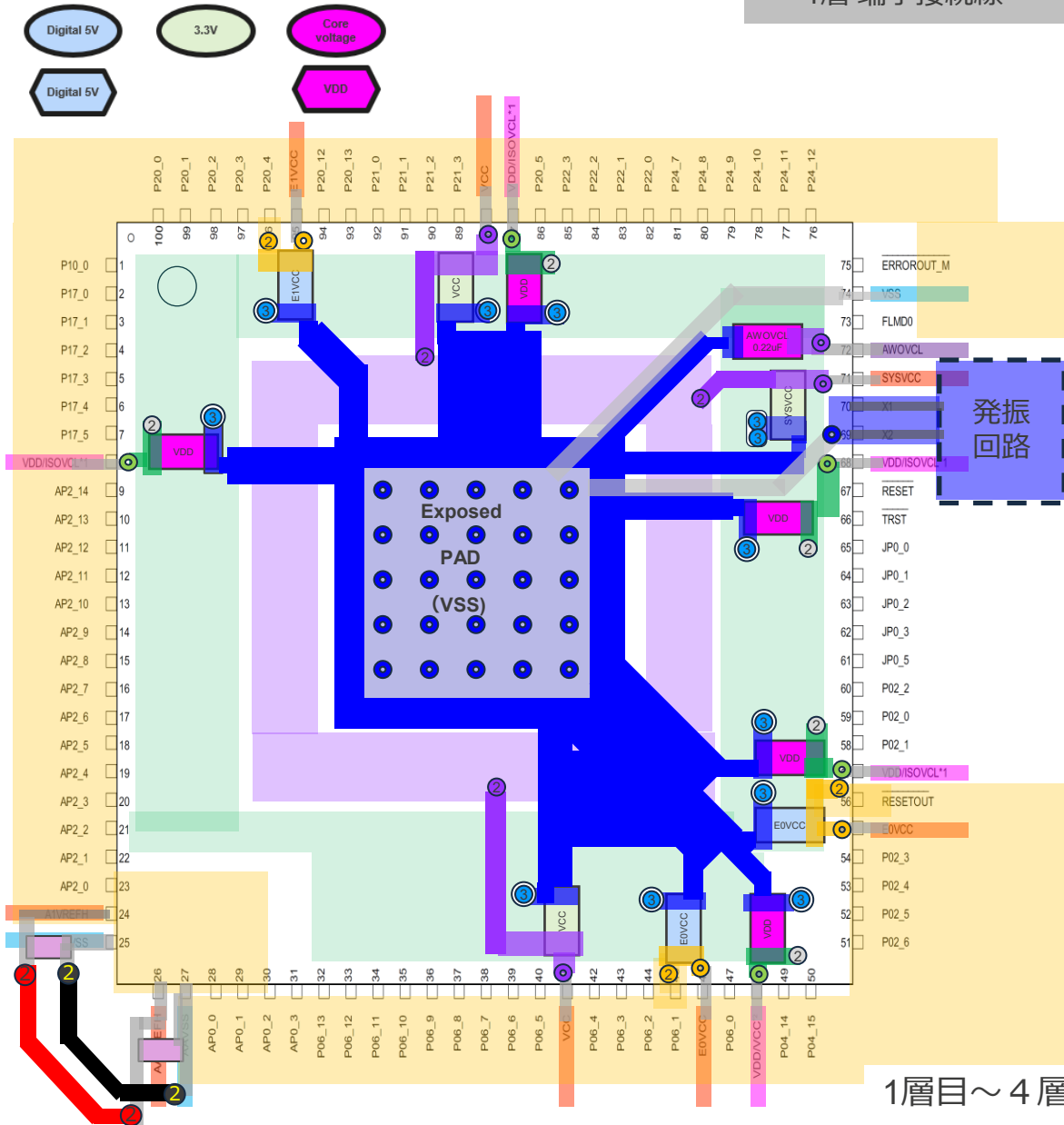

1層 端子接続線

2層 EVCC供給

3層 GND
(非表示)
発振回路の
直下は抜き
パターン

4層 VSS配線

2層VDD供給

4層 GND (発振回路)

2層VCC供給

4層 EVCC配線

2層Analog

4層 VDD配線

4層 VCC配線

2層Analog-GND

◎内層の電源/グランド層と接続しないVIA
○内の数字は4層と各VIAの接続

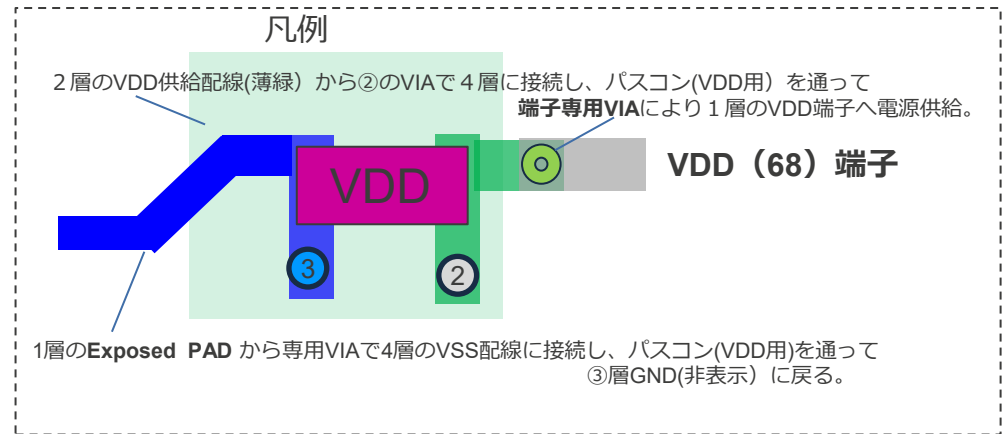

- 凡例
- 2層のVDD供給配線(薄緑) から②のVIAで4層に接続し、パソコン(VDD用)を通して端子専用VIAにより1層のVDD端子へ電源供給。
- 1層のExposed PAD から専用VIAで4層のVSS配線に接続し、パソコン(VDD用)を通して③層GND(非表示)に戻る。
- 緑 : VDD
- 紫 : System(VCC/SYSVCC)電源
- 赤 : Analog(AxVCC)電源
- 黄色 : Digital IO(ExVCC)電源
- 青 : VSS

1層目～4層目を重ね合わせ表示(灰色が1層目、カラーが2層目、4層目)

U2C4(3V)/U2C2 eVR QFP100 パソコン及びVIA配置例

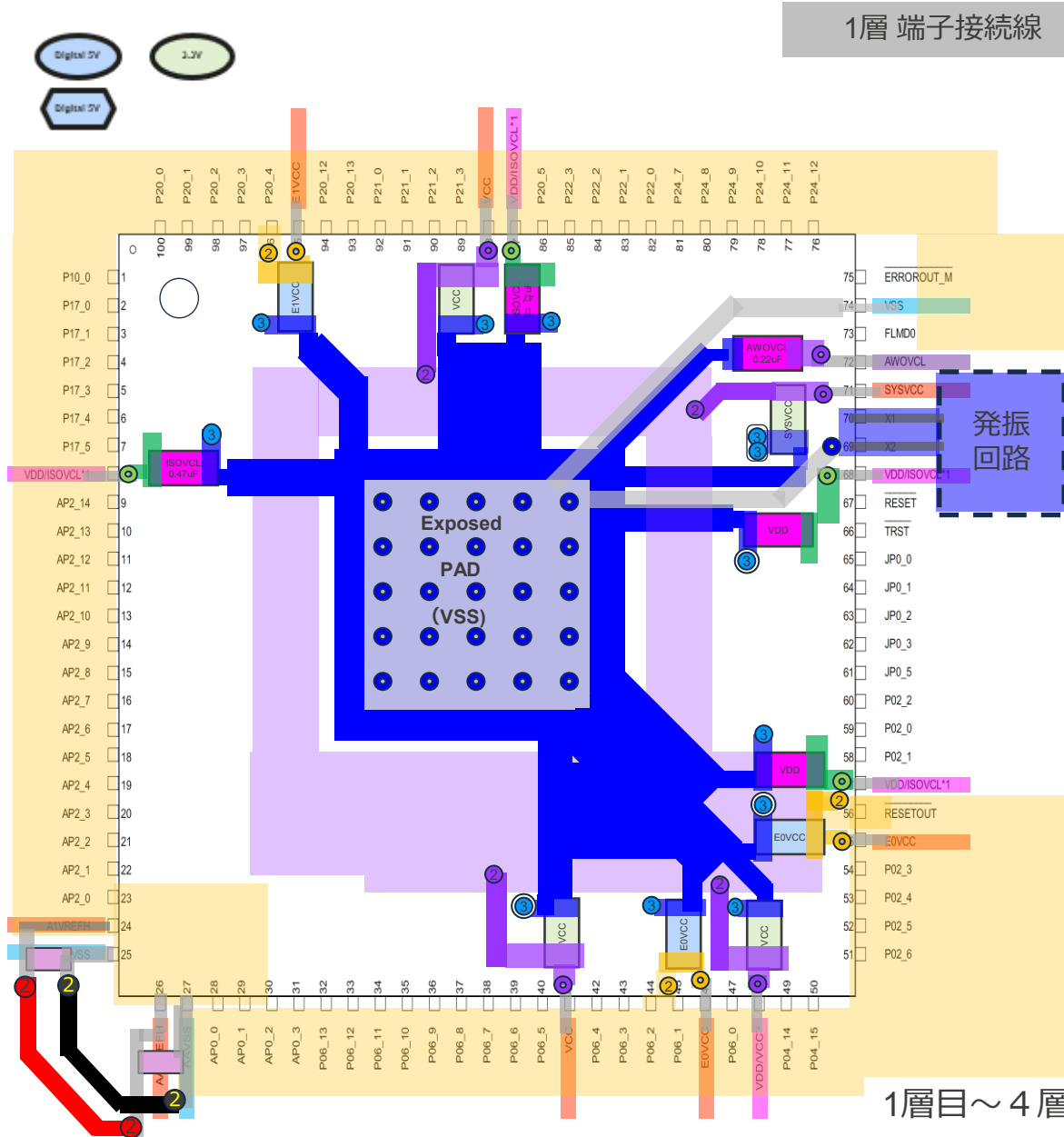

1層 端子接続線

2層 EVCC供給

3層 GND
(非表示)
発振回路の
直下は抜き
パターン

4層 VSS配線

4層 GND (発振回路)

4層 EVCC配線

4層 ISOVCL配線

4層 VCC配線

2層VCC供給

2層Analog

2層Analog-GND

◎内層の電源/グランド層と接続しないVIA
○内の数字は4層と各VIAの接続

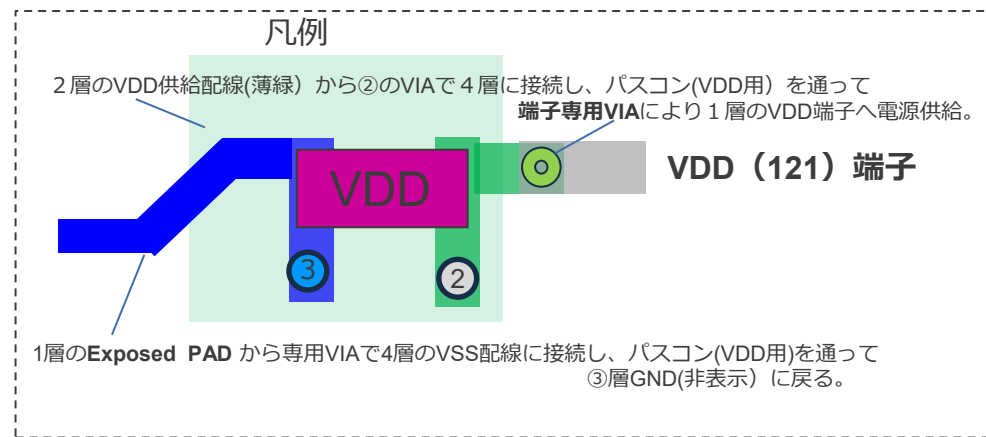

- 緑 : ISOVCL
- 紫 : System(VCC/SYSVCC)電源
- 赤 : Analog(AxVCC)電源
- 黄色 : Digital IO(ExVCC)電源
- 青 : VSS

1層目～4層目を重ね合わせ表示(灰色が1層目、カラーが2層目、4層目)

U2C4(5V) eVR QFP100 パスコン及びVIA配置例

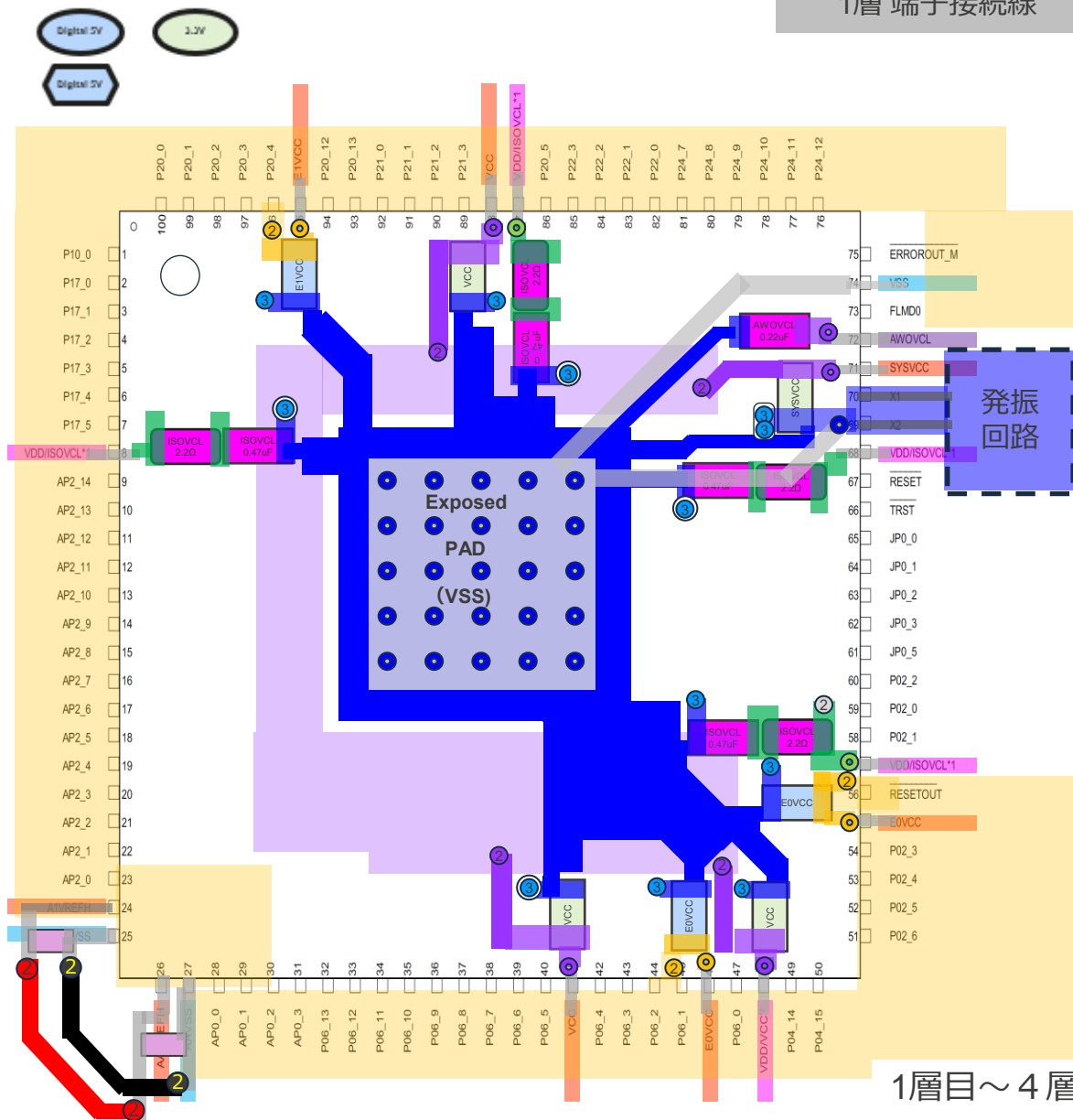

1層 端子接続線

2層 EVCC供給

3層 GND
(非表示)
発振回路の
直下は抜き
パターン

4層 VSS配線

4層 GND (発振回路)

4層 EVCC配線

4層 ISOVCL配線

4層 VCC配線

2層VCC供給

2層Analog

2層Analog-GND

◎内層の電源/グランド層と接続しないVIA
○内の数字は4層と各VIAの接続

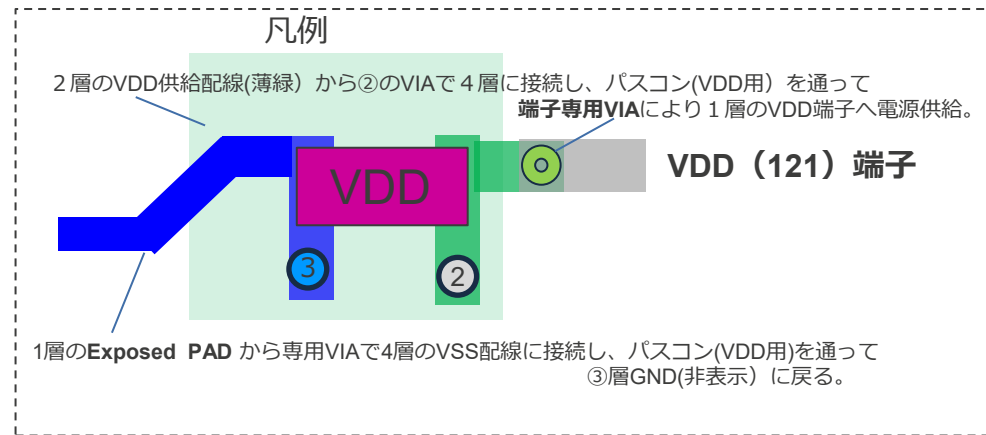

- 緑 : ISOVCL
- 紫 : System(VCC/SYSVCC)電源
- 赤 : Analog(AxVCC)電源
- 黄色 : Digital IO(ExVCC)電源
- 青 : VSS

1層目～4層目を重ね合わせ表示(灰色が1層目、カラーが2層目、4層目)

[Renesas.com](https://www.renesas.com)