

WS040-ACDCWIFIEV1Z

Wi-Fi Connected SMPS with Ultra-Low Standby Power Manual

Description

The WS040-ACDCWIFIEV1Z is a high-efficiency AC/DC power supply solution optimized for always-connected IoT applications. It delivers ultra-low standby power, measuring as low as 5mW, while providing seamless wireless connectivity through integrated Wi-Fi and Bluetooth® Low Energy.

The Renesas iW1816, a digital power controller with integrated bipolar transistor, powers the WS040-2. The iW1816 offers industry-leading average efficiency and one of the lowest standby power profiles available. With an advanced primary-side regulation, it reduces the requirement for external components and simplifies design and lowers BOM cost.

In addition, the DA16600 module features an intelligent power management architecture that disables inactive subsystems to minimize power consumption. When active, it supports ultra-low-power TX/RX modes for efficient wireless data transmission. Together, the iW1816 and DA16600 provide a robust and energy-efficient platform ideal for IoT devices requiring constant connectivity with minimal power draw.

Features

- AC/DC Featuring a primary-side regulated power supply IC, delivering a cost-effective solution with ultra-low standby current
- Wi-Fi and BLE maintain persistent network connection in sleep mode 3, minimizing power consumption
- The Wi-Fi module can be easily configured for network access via an Android application
- A signal from the WiFi module to the system initiated by an Android app to power on or off system blocks

Contents

- iW1816 – ACDC AccuSwitch™ Off-Line Digital PWM Converter with 800V Bipolar Power Transistor
- DA16600MOD – Ultra-Low Power Wi-Fi + Bluetooth Low Energy Combo Modules
- WS040-ACDCWIFIEV1Z – Cost-effective Solution Board

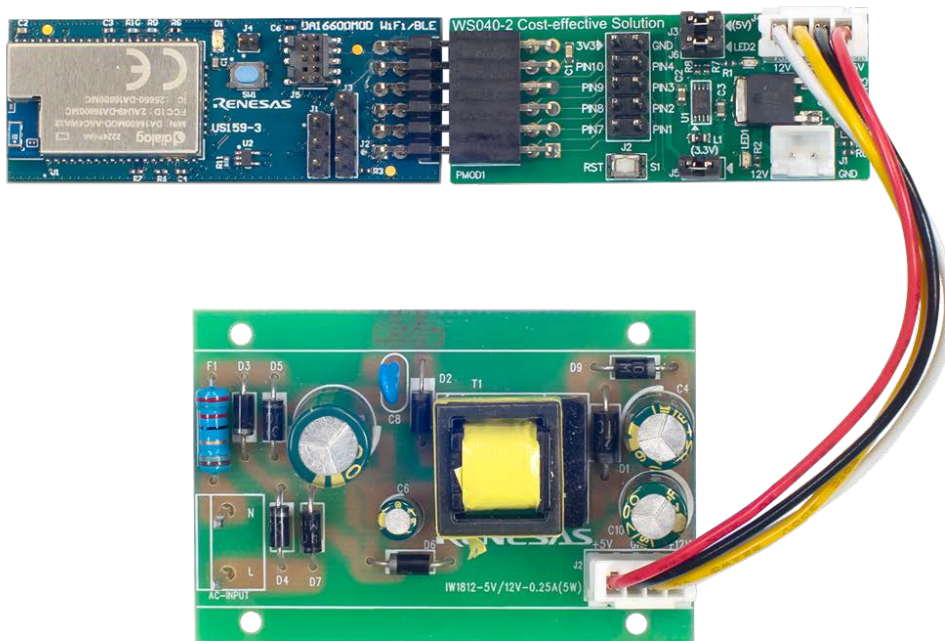

Figure 1. WS040-ACDCWIFIEV1Z Reference Design

Contents

1. Contents	3
1.1 Hardware Components	3
1.2 Software Components	3
2. Features	4
2.1 iW1816	4
2.2 DA16600	4
3. Solution	4
4. Set Up the Demo	5
4.1 Install the iOS or Android App	5
5. Run the Demo	6
5.1 Provisioning	6
5.2 Switch On/Off Operation	7
6. Power Consumption Evaluation	8
7. Reference Documents	9
7.1 Technical Updates and Technical News	9
7.2 Website and Support	9
8. Revision History	10

1. Contents

To help set up this demonstration, the following sections detail the required hardware and software components.

1.1 Hardware Components

- AC/DC board (Thor) – iW1816-20, 90-264Vac input, 12V/250mA 5V/250mA dual-output home appliance board
- Wi-Fi/BLE board (Loki) – US159-DA16600EVZ, a highly-integrated module that integrates a low-power Bluetooth LE DA14531 for a network-connecting configuration and a low-power Wi-Fi DA16200 for network connection
- WS040-2 Cost-effective Solution board – Connects an AC/DC and DA16600PMOD and controls a 12V output to an external system controller
- Adapter Cable (4-pins connector) – Connects between the AC/DC board and the WS040-2 cost-effective solution board, including 12V, 5V and GND, totaling for a 4-pin connecting line
- Mobile Phone (Android system with application) – Provides configuration of a Wi-Fi router and controls the on/off switch.

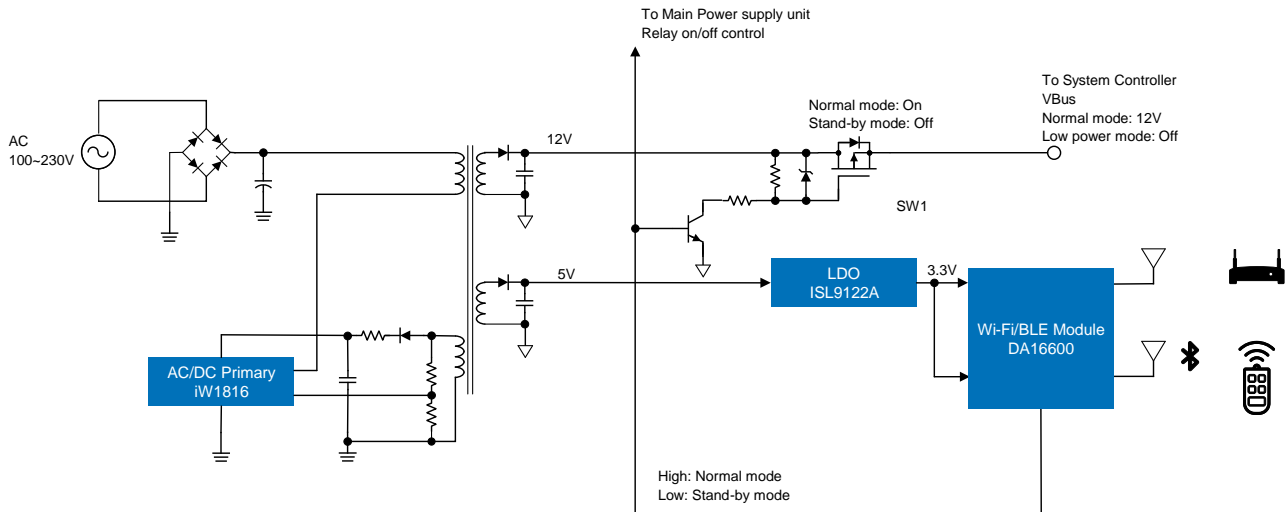

Figure 2. System Block Diagram

1.2 Software Components

Category	Item	Remark
DA16600 module	Image	da16600_da14531_1_download.ttl in img folder, with DA14531_1 subfolder, DA16600_FBOOT-GENxx and DA16600_FRTOS-GENxx files.
	Software	Tera Term
Mobile application	iOS / Android application	Renesas WiFiProvisioning.apk for iOS or Android
		An app to configure and control a system that is designed specifically for this application. Found on Google Play, Apple store, or downloadable at the Renesas website on the DA16600MOD product page.

2. Features

- AC/DC featuring a primary-side regulated power supply IC (iW1816), delivering a cost-effective solution with ultra-low standby current
- Wi-Fi and BLE maintain persistent network connection in Sleep mode 3, minimizing power consumption
- The Wi-Fi module can be easily configured for network access through an Android application
- A signal from the WiFi module to the system initiated by an Android app to power on or off system blocks

2.1 iW1816

The iW1816 is a high-performance AC/DC power supply control device to provide high efficiency along with a number of key built-in protection features while minimizing the external component count, simplifying EMI design, and lowering the total bill of material cost. The iW1816 removes the requirement for secondary feedback circuit while achieving excellent line and load regulation. It also eliminates the requirement for loop compensation components while maintaining stability in all operating conditions. The Renesas innovative proprietary technology ensures that power supplies built with the iW1816 can achieve highest average efficiency, lowest standby power consumption, and a fast smooth startup with a wide range of output voltage and capacitive loads.

2.2 DA16600

The DA16600 series is a highly integrated ultra-low-power Wi-Fi® + Bluetooth Low Energy Combo Module solution. The DA16200 (Wi-Fi module) and DA14531 (Bluetooth module) shut down every micro element of the chip that is not in use, which creates a power consumption that is near zero when not actively transmitting or receiving data. The DA16600 also enables ultra-low-power transmission and reception modes when the SoC must be awake to exchange information with other devices. Advanced algorithms enable Sleep mode until the exact moment when wake-up is required to transmit or receive data.

3. Solution

This solution demonstrates a switched-mode power supply (SMPS) that powers a remote system with cloud-controlled, remotely switchable on/off functionality. Designed for ultra-low power consumption, the system minimizes AC input draw during sleep modes. It uses secure, bidirectional communication between edge devices and a mobile application to enable real-time control and monitoring. The architecture is optimized for energy efficiency, making it well-suited for smart home and industrial IoT applications.



Figure 3. Solution Image

4. Set Up the Demo

4.1 Install the iOS or Android App

Use the Renesas Electronics Wi-Fi provisioning mobile app for iOS to configure the DA1660 and DA1660 Wi-Fi profile information.

For Android, the customized Renesas WiFiProvisioning.apk app is available at the Google Play Store or the Renesas website on the [DA1660MOD](#) product page (*DA16200 DA16600 Provisioning Mobile App*). The app is for Android phones and for demonstration purposes only and not commercial use. Complete the following steps to set up the application:

1. Install the Renesas WiFiProvisioning.apk.
2. Open the app, allow the location and storage features, and enable the Wi-Fi function.

5. Run the Demo

5.1 Provisioning

The DA16600 supports a provisioning feature called the Soft AP mode to facilitate the network configuration. To use this feature, first turn on the Bluetooth on a mobile phone.

1. When the external wireless router in use for internet connectivity changes, insert the jumper J4 (highlighted in red in Figure 4) to initiate a factory-reset mode for re-provisioning by using the mobile application.
Note: Provisioning is not required if there is no change to the router.

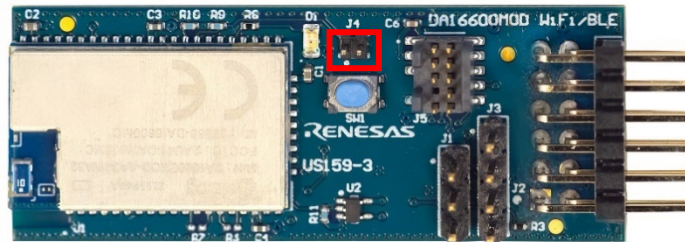
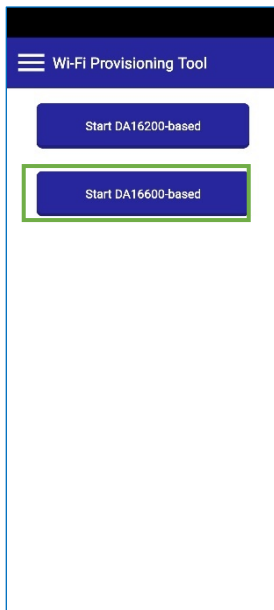
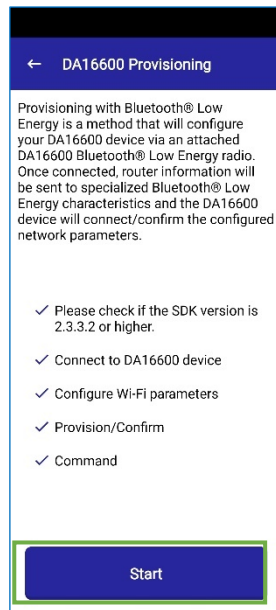

Figure 4. Loki Board (DA16600)

2. Supply power to the system and wait eight seconds.
3. Remove the jumper J4, the DA16600 enters the provisioning mode.
4. Start the application (Renesas WiFiProvisioning) and complete the subsequent steps to complete the provisioning process.



1. Click the **Start DA16600-based** button.



2. Click the **Start** button.

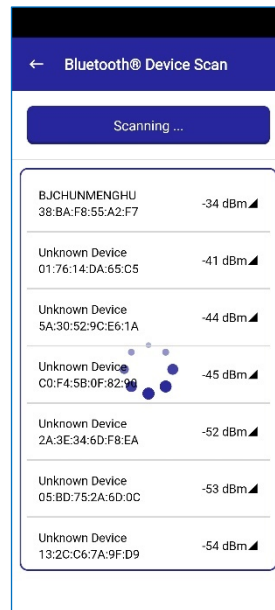

3. Scanning Bluetooth® Low Energy devices.

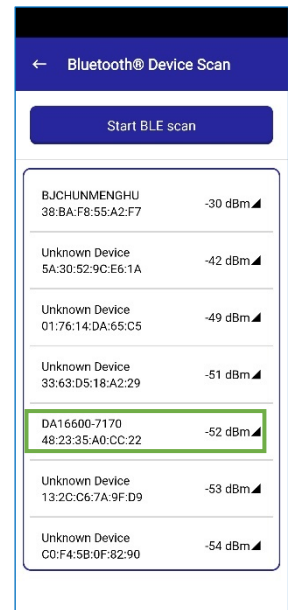

4. Click the Bluetooth® Low Energy device name of DA16600.

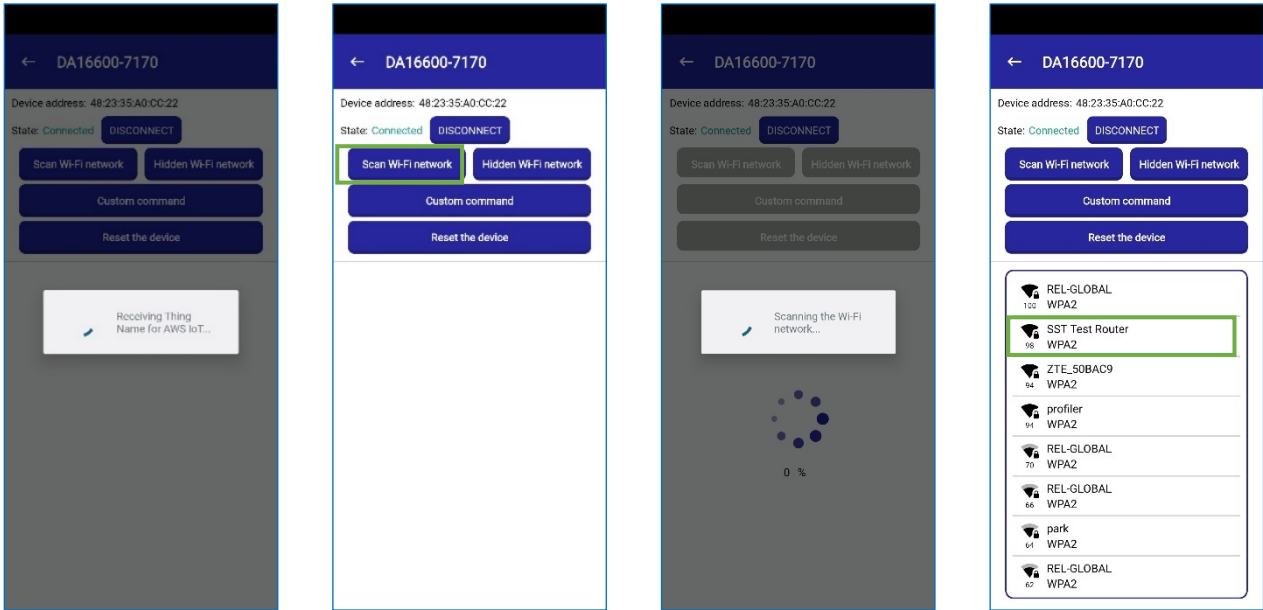

5. Wait for the connection to finish.
6. After discovering the services and characteristics of DA16600 Bluetooth® Low Energy, click the **Start Wi-Fi network** button.
7. The app receives WiFi network information from DA16600, and a list appears.
8. Click the name of the Wi-Fi network in the list.

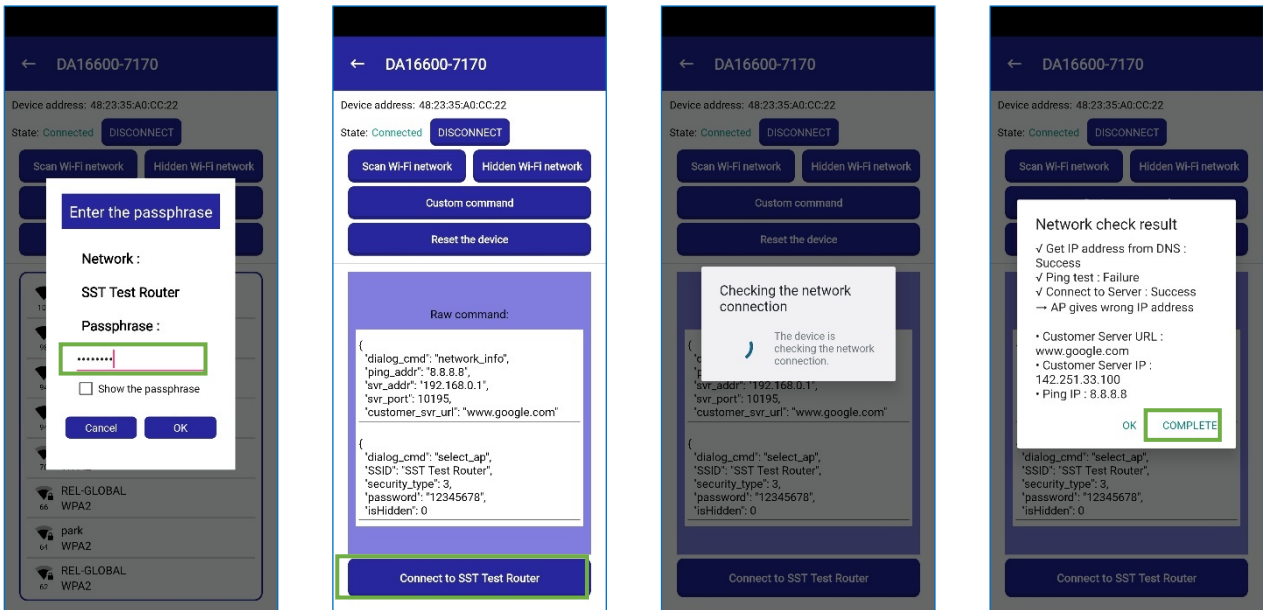

9. Enter the passphrase and click the **OK** button.
10. Click the **Connect to (Wi-Fi network name)** button.
11. DA16600 is checking the network connection.
12. The provisioning has ended successfully. Click **COMPLETE** to finish the provisioning.

5.2 Switch On/Off Operation

For ease of use, the WS040 board has a MOSFET that gates the 12V supply to an external load. This switch can be toggled with the Renesas WiFiProvisioning App on the AWS IoT page operation. The 12V tolerant load

can be connected between Pins 1 and 2 on J1 found on the WS040 board. A second LED lights when J1 is powered.

Complete the following steps to complete this operation.

Note: The switch can look different depending on the version of the apk downloaded.

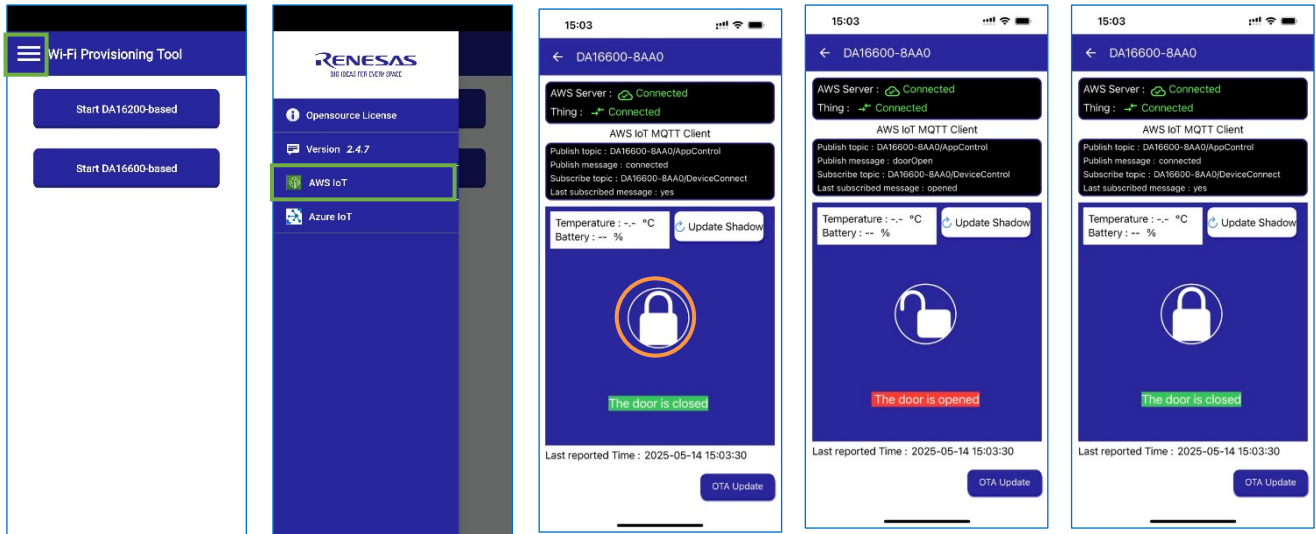

1. Click the **Menu** icon.
2. Click the **AWS IoT** button.
3. Click the **lock** icon to enable or disable power output.
4. Turn the switch on (The lock is opened).
5. Turn the switch off (The lock is closed).

6. Power Consumption Evaluation

Table 1 lists the power consumption values in standby and active modes, while the DA16600 is running in standby or low power mode connected to the access point for the solution. The test is completed with a 10-minute integral test, which averages the power over a 10 minute interval.

Table 1. Power Consumption

Voltage (Vac)	Power (mW)	
	Standby	Low Power
90	3.9	5.6
110	4.2	6.3
220	10.8	12.7
264	14.6	16.8

The current consumption of the Wi-Fi/BLE module is measured by connecting an ammeter in series with WS040-2 cost-effective solution board. *Note:* To test the minimal current in the system, J6 must be removed to bypass the 5V indicator LED (see Figure 5).

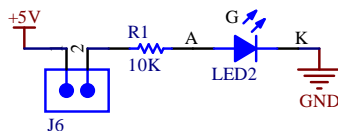

Figure 5. J6 and 5V Indicator LED

To evaluate the current consumption of the 5V system, connect the ammeter in series with J3. For assessing the current consumption of the Wi-Fi/BLE module, connect the ammeter in series with J5.

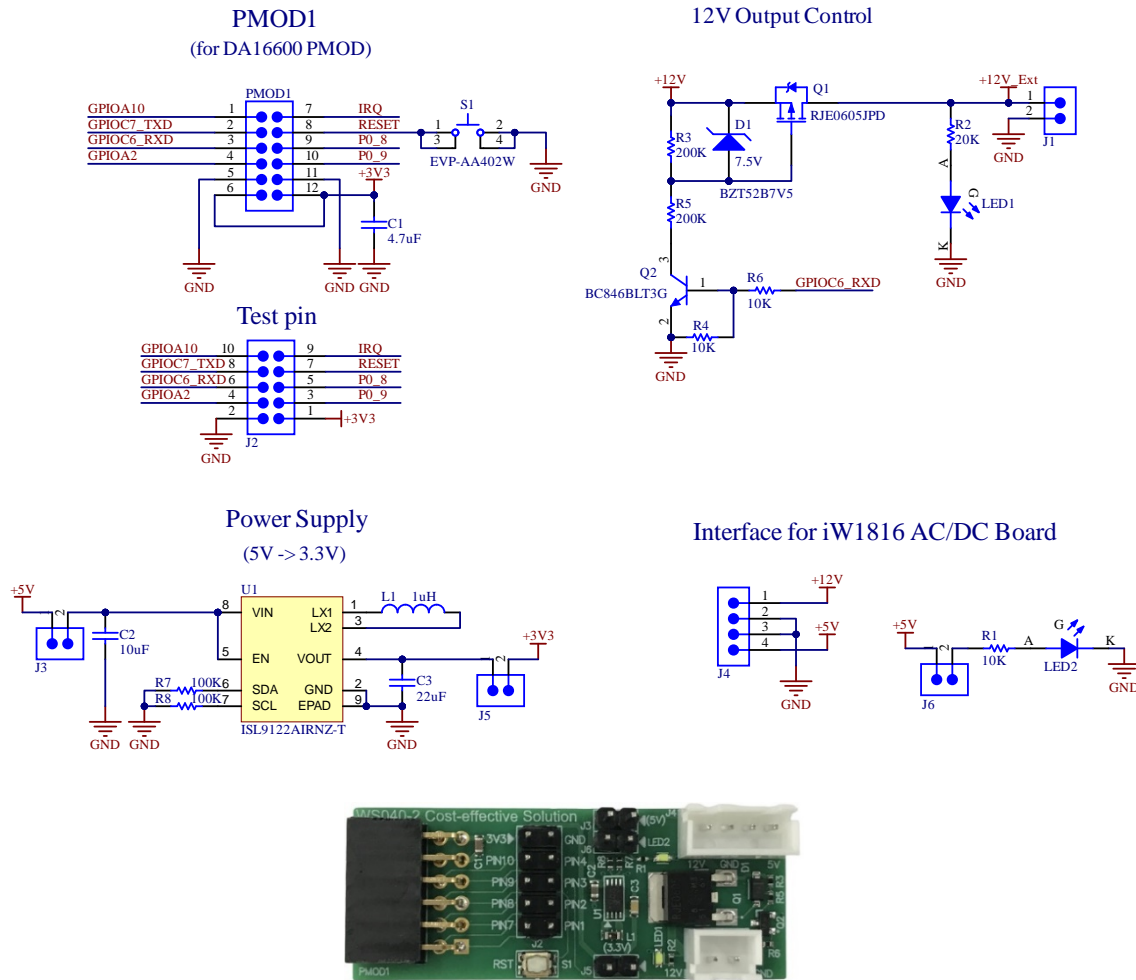

Figure 6. Close-up of WS040-ACDCWIFIEV1Z Board and Schematic

7. Reference Documents

- [iW1816 - AccuSwitch™ Off-Line Digital PWM Converter with 800V Bipolar Power Transistor | Renesas](#)
- [DA16600MOD - Ultra-Low Power Wi-Fi + Bluetooth Low Energy Combo Modules for Battery Powered IoT Devices | Renesas](#)

7.1 Technical Updates and Technical News

The latest information can be downloaded from the Renesas Electronics Website.

7.2 Website and Support

- Website – <https://www.renesas.com/>
- Inquiries – <https://www.renesas.com/contact/>

8. Revision History

Revision	Date	Description
1.00	July 2, 2026	Initial release.

IMPORTANT NOTICE AND DISCLAIMER

RENESAS ELECTRONICS CORPORATION AND ITS SUBSIDIARIES (“RENESAS”) PROVIDES TECHNICAL SPECIFICATIONS AND RELIABILITY DATA (INCLUDING DATASHEETS), DESIGN RESOURCES (INCLUDING REFERENCE DESIGNS), APPLICATION OR OTHER DESIGN ADVICE, WEB TOOLS, SAFETY INFORMATION, AND OTHER RESOURCES “AS IS” AND WITH ALL FAULTS, AND DISCLAIMS ALL WARRANTIES, EXPRESS OR IMPLIED, INCLUDING, WITHOUT LIMITATION, ANY IMPLIED WARRANTIES OF MERCHANTABILITY, FITNESS FOR A PARTICULAR PURPOSE, OR NON-INFRINGEMENT OF THIRD-PARTY INTELLECTUAL PROPERTY RIGHTS.

These resources are intended for developers who are designing with Renesas products. You are solely responsible for (1) selecting the appropriate products for your application, (2) designing, validating, and testing your application, and (3) ensuring your application meets applicable standards, and any other safety, security, or other requirements. These resources are subject to change without notice. Renesas grants you permission to use these resources only to develop an application that uses Renesas products. Other reproduction or use of these resources is strictly prohibited. No license is granted to any other Renesas intellectual property or to any third-party intellectual property. Renesas disclaims responsibility for, and you will fully indemnify Renesas and its representatives against, any claims, damages, costs, losses, or liabilities arising from your use of these resources. Renesas' products are provided only subject to Renesas' Terms and Conditions of Sale or other applicable terms agreed to in writing. No use of any Renesas resources expands or otherwise alters any applicable warranties or warranty disclaimers for these products.

(Disclaimer Rev.1.01)

Corporate Headquarters

TOYOSU FORESIA, 3-2-24 Toyosu,
Koto-ku, Tokyo 135-0061, Japan
www.renesas.com

Trademarks

Renesas and the Renesas logo are trademarks of Renesas Electronics Corporation. All trademarks and registered trademarks are the property of their respective owners.

Contact Information

For further information on a product, technology, the most up-to-date version of a document, or your nearest sales office, please visit www.renesas.com/contact-us/.