

ISL73141BMREFEVKIT1Z, ISL73141BMREFEVKIT2Z

8-Cell Battery Monitor Reference Design

The ISL73141BMREFEVKIT1Z/KIT2Z evaluation kits and iRADNavigator software GUI demonstrate the [ISL73141SEH](#) 14-bit SAR ADC in an 8-cell battery voltage monitoring application. Monitoring of the lithium battery cell voltages is critical to protect the battery against undervoltage and overvoltage conditions.

The ISL73141BMREFEV1Z 8-cell battery monitor main board uses six of the [ISL70444SEH](#) radiation hardened (RH) quad 40V rail-to-rail op-amps, an RH [ISL71830SEH](#) 16-channel multiplexer, an RH [ISL73141SEH](#) 14-bit 1000ksps SAR ADC paired with the [ISL71091SEH40](#) voltage reference, to monitor each of the eight cell voltages of the battery.

The evaluation kit also comes with a V_{BAT} 8-cell resistor divider (BMSVOLTDIV8REFEV1Z) power/battery emulator board. It powers the main ISL73141BMREFEV1Z board and provides the eight cell voltages to be monitored.

The ISL73141BMREFEV1Z board is intended to be used with the Vorago VA41620 MCU board and iRADNavigator software. The voltages are digitized by the ISL73141SEH ADC and read by the iRADNavigator software.

Two [HS-117RHs](#) Adjustable Positive Voltage Regulators provide the AVCC (5V) and DVCC (3.3V) supply rails to the ISL73141SEH ADC and ISL71830SEH multiplexer. The ISL71091SEH40 precision voltage reference provides the VREF (4.2V) for the ISL73141SEH to set the analog input range. For a block diagram of the reference design circuit, see [Figure 1](#).

This evaluation system supports a text or graphical display of the total battery voltage and each of the eight cell voltages generated by the BMSVOLTDIV8REFEV1Z resistor divider power board in the iRADNavigator software. The battery voltage and the C8 to C1 cell voltages can be displayed in the software in a text-based format and displayed in a graphical format simultaneously.

The included Vorago VA41620 MCU board must be mated to the underside of ISL73141BMREFEV1Z evaluation board to acquire data and observe total battery voltage and the individual eight battery cell voltages.

Features

This evaluation kit demonstrates an example signal chain that monitors the cell voltages for an 8-cell lithium-ion battery application, with a maximum cell voltage of 4.5V, while highlighting the accuracy of all three of the main system components; the ISL70444SEH buffered differential front end, the ISL71830SEH multiplexer, and the SAR ADC.

- Accurate cell voltage measurement
- Buffered differential front end
- Multiple battery cell voltage observation configurations
- User-friendly software GUI

Specifications

- Monitor cell voltages of 8-cell batteries
- Main system components support -55°C to +125°C operation
- Supporting components support -40°C to +85°C operation

Kit Contents

- ISL73141BMREFEV1Z battery monitor evaluation board
- BMSVOLTDIV8REFEV1Z V_{BAT} resistor divider power board
- Vorago VA41620 MCU board (KIT1 only)
- USB 2.0 cable type A to micro USB (KIT1 only)
- USB 2.0 cable with UART adapter (DTech DT-6554 or similar) (KIT1 only)

Required Equipment

To properly operate the ISL73141BMREFEVKIT1Z/KIT2Z system the following equipment is required:

- +8V to +36V DC power supply
- Renesas iRADNavigator software (download from Renesas website)
- PC running Windows 10 or greater

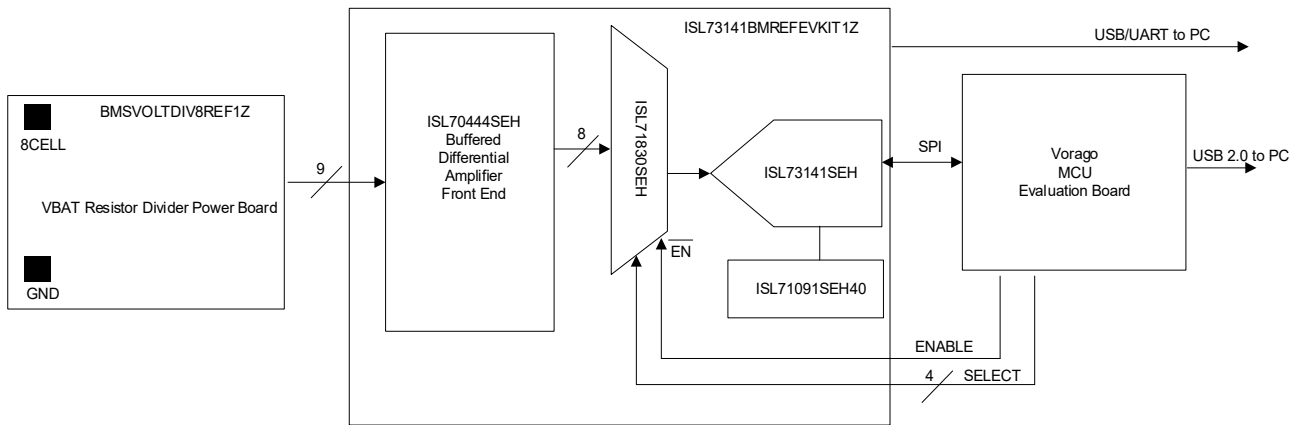

Figure 1. ISL73141BMREFEVKIT1Z Block Diagram

Contents

1. Functional Description	3
1.1 Evaluation Board Operation	5
1.2 Connecting the VA41620 MCU, ISL73141BMREFEV1Z, and BMSVOLT DIV8 REF1Z Evaluation Boards	5
1.2.1 iRADNavigator Board Selection	7
1.2.2 iRADNavigator Voltage Monitor Selection and Measurements	9
1.2.3 iRADNavigator Monitor Panel	11
1.3 iRADNavigator MCU Firmware Update	14
2. Board Design	16
2.1 ISL73141BMREFEV1Z Evaluation Board	16
2.1.1 Board Schematics	17
2.1.2 Bill of Materials	19
2.1.3 Board Layout	21
2.2 BMSVOLT DIV8 REF1Z Resistor Divider Power Board	23
2.2.1 Board Schematics	23
2.2.2 Bill of Materials	23
2.2.3 Board Layout	24
3. Ordering Information	25
4. Revision History	25

1. Functional Description

The ISL73141BMREFEV1Z voltage monitor reference design board operates with the BMSVOLTDIV8REFEV1Z VBAT resistor divider power board. However, it can be mated to an actual 8-cell battery with compatible connectors and topologies to monitor or measure the cell voltages of a real battery. This user guide discusses the operation of the reference design platform and the battery cell voltages that are monitored. [Table 1](#) shows accuracy data for the eight battery cell voltages with battery voltages of 16V, 24V, and 33.6V.

Table 1. ISL73141BMREFEVKIT1Z Battery Cell Voltages versus GUI Measured Value

Cell #	Battery Voltage: 16.000V, Cell Voltage: 2.000V			Battery Voltage: 24.029V, Cell Voltage: 3.00363V			Battery Voltage: 33.634V, Cell Voltage: 4.20425V		
	Cell Voltage (V)	GUI Value (V)	Accuracy (mV)	Cell Voltage (V)	GUI Value (V)	Accuracy (mV)	Cell Voltage (V)	GUI Value (V)	Accuracy (mV)
8	1.9992	1.999	0.20	3.0028	3.002	0.80	4.2034	4.202	1.40
7	1.9997	1.999	0.70	3.0033	3.002	1.3	4.2036	4.201	2.6
6	2.0000	2.000	0	3.0038	3.003	0.80	4.2047	4.203	1.00
5	2.0002	2.000	0.20	3.0039	3.003	0.90	4.2043	4.203	1.70
4	2.0006	1.999	1.6	3.0046	3.002	2.6	4.2058	4.202	3.8
3	1.9994	1.999	0.40	3.0027	3.002	0.70	4.2027	4.202	0.70
2	1.9999	2.000	-0.10	3.0034	3.003	0.40	4.2036	4.203	0.60
1	1.9998	2.000	-0.20	3.0034	3.003	0.40	4.2038	4.203	0.80

[Figure 28](#) shows the top side of the ISL73141BMREFEV1Z main board.

System configuration for the ISL73141BMREFEV1Z main board:

- Four ISL70444SEH quad op-amps configured as buffers for hi-impedance inputs to not drain the battery cells.
- Two ISL70444SEH quad op-amps configured as differential amplifiers to remove the common mode cell voltage and output the eight cell differential voltages.
- One ISL71830SEH 5V 16-channel MUX to select between the eight cell voltages.
- One ISL71091SEH40 4.096V voltage reference trimmed with output voltage of 4.2V.
- One ISL73141SEH 14-bit SAR ADC to digitize the cell voltage from MUX.
- Three HSYE117RH adjustable positive voltage regulators provide the power supply voltages for the ISL73141SEH ADC, the ISL71830SEH MUX, and the ISL70191SEH40 voltage reference.

Figure 2 shows the BMSVOLTDIV8REFEV1Z V_{BAT} resistor divider power board connection to the ISL73141BMREFEV1Z main board.

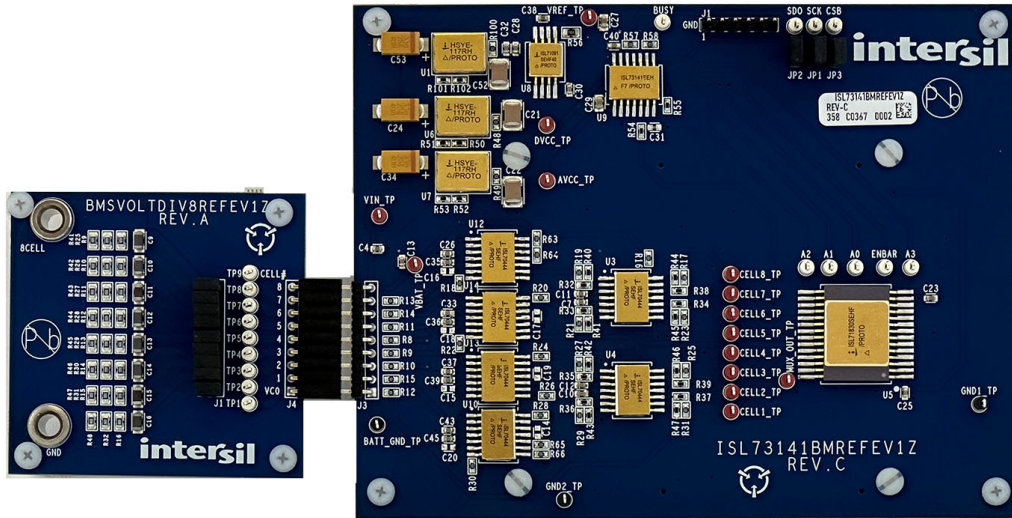

Figure 2. ISL73141BMREFV1Z Main Board Connected to BMSVOLTDIV8REFEV1Z V_{BAT} 8-Cell Power Board

The V_{BAT} 8-cell resistor divider power board (BMSVOLTDIV8REFEV1Z) powers the ICs on the main ISL73141BMREFEV1Z board and generates the eight battery cell voltages to the main board through the J3 male connector for processing and display of each cell voltage on the PC GUI.

An 8V to 36V DC power supply connected to the 8CELL and GND banana jack connectors on the BMSVOLTDIV8REFEV1Z V_{BAT} resistor divider power board provides the power to the V_{BAT} 8-cell resistor divider power board and the ISL73141BMREF1Z main board. *Note:* An actual 8-cell battery can be connected to the main board at the J3 8-pin male connector to evaluate a real battery.

All the main system components of the signal chain are radiation hardened products. The remaining components, the surface mount passives, are commercial products that are not radiation hardened and may or may not support extended temperatures used in a typical space application.

Figure 3 shows the Vorago VA41620 MCU board connected to the bottom of the ISL73141BMREFEV1Z voltage monitor reference design board. It controls the MUX and ADC to display the cell voltages in the iRADNavigator software GUI.

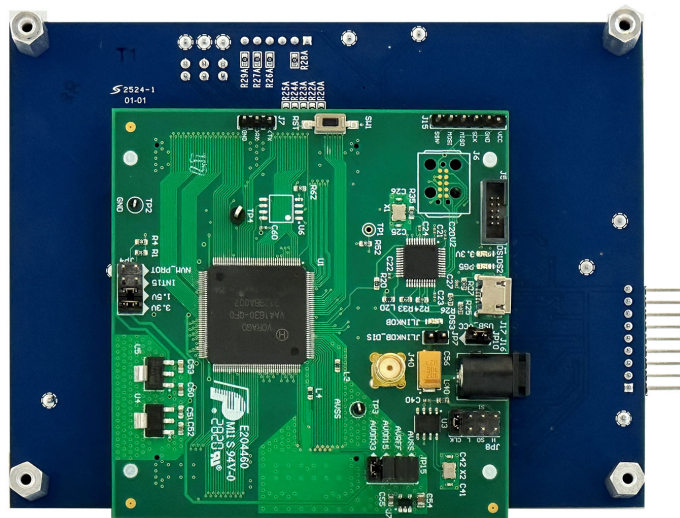

Figure 3. ISL73141BMREFEVKIT1Z Evaluation Board with Vorago VA41620 MCU Evaluation Board

The Vorago VA41620 MCU is also radiation hardened by design. The remaining components, the surface mount passives, are commercial products that are not radiation hardened and might not support extended temperatures used in a typical space application.

A USB 2.0 to UART cable is connected to J1, located on top of the ISL73141BMREFEV1Z board, with the GND pin of the cable connected to the side of the header, with J1 showing in the silkscreen. This cable collects the ADC data from the MCU, which is subsequently processed in the iRADNavigator software GUI. Power is provided to the Vorago MCU through the USB 2.0 cable that connects to J17 on the Vorago VA41620 evaluation board.

1.1 Evaluation Board Operation

The ISL73141BMREFEVKIT1Z reference design operates with the ISL73141BMREFEV1Z main board connected with the BMSVOLTDIV8REFEV1Z V_{BAT} resistor divider power board to show the total battery voltage and the eight battery cell voltages. The cell voltages are input to the ISL71830SEH multiplexer on the ISL73141BMREFEV1Z board. The iRADNavigator software GUI drives the voltage selection allowing the ISL73141SEH ADC at a given time to perform a measurement. The ISL71091SEH40 voltage reference provides the reference voltage (4.2V) to the ISL73141SEH ADC, which in turn sets the analog input range of the ISL73141SEH. The cell voltages are scaled down by the differential op-amp circuitry on the ISL73141BMREFEV1Z board. The cell input voltage scale, when there is a 4.5V cell voltage, results in a 4.0V input voltage to the ISL73141SEH. This scale provides 200mV of headroom between the ADC input voltage and the ADC voltage reference.

The ISL70444SEH, ISL71830SEH, ISL71091SEH40, and ISL73141SEH devices on the evaluation board support operation from -55°C to +125°C. However, many components (namely the surface mount passive components used on the evaluation board) support a commercial temperature range of -40°C to +85°C. This evaluation board operates under ambient temperature conditions at or near 25°C.

1.2 Connecting the VA41620 MCU, ISL73141BMREFEV1Z, and BMSVOLTDIV8REFEV1Z Evaluation Boards

Complete the following steps to connect the boards successfully.

1. Connect the supplied Vorago VA41620 MCU evaluation board to the bottom of the ISL73141BMREFEV1Z main board at connectors J1A and J2A. There are plastic standoffs on the board to ensure the MCU gets connected properly to the main board.
2. Connect the V_{BAT} resistor divider power board, 9-pin female connector to the J3 9-pin male connector on the ISL73141BMREFEV1Z main board.
3. Connect the supplied USB type-A to micro USB cable from the PC to the Vorago VA41620 MCU evaluation board at J17 on the MCU board.
4. Observe LED DS2 on the Vorago VA41620 board to ensure it starts blinking. When the LED blinks, connect the supplied D-Tech FTDI USB to the UART cable from the PC to the J1 6-pin male connector at the top of the ISL73141BMREFEV1Z main board.
5. Press the reset button (SW1) on the Vorago VA41620 MCU evaluation board to load the firmware from the MRAM into the VA41620 MCU.
6. Connect a 36V DC power supply to the BMSVOLTDIV8REFEV1Z V_{BAT} resistor divider board at the banana jacks labeled 8CELL and GND. Connect the positive terminal at 8CELL banana jack and the negative terminal at the GND banana jack. Set the supply voltage to the battery voltage required to evaluate. For example, set it at 24V to evaluate battery cell voltages of 3V. Vary the supply voltage from 8V to 36V to monitor how the system evaluates different cell voltages.

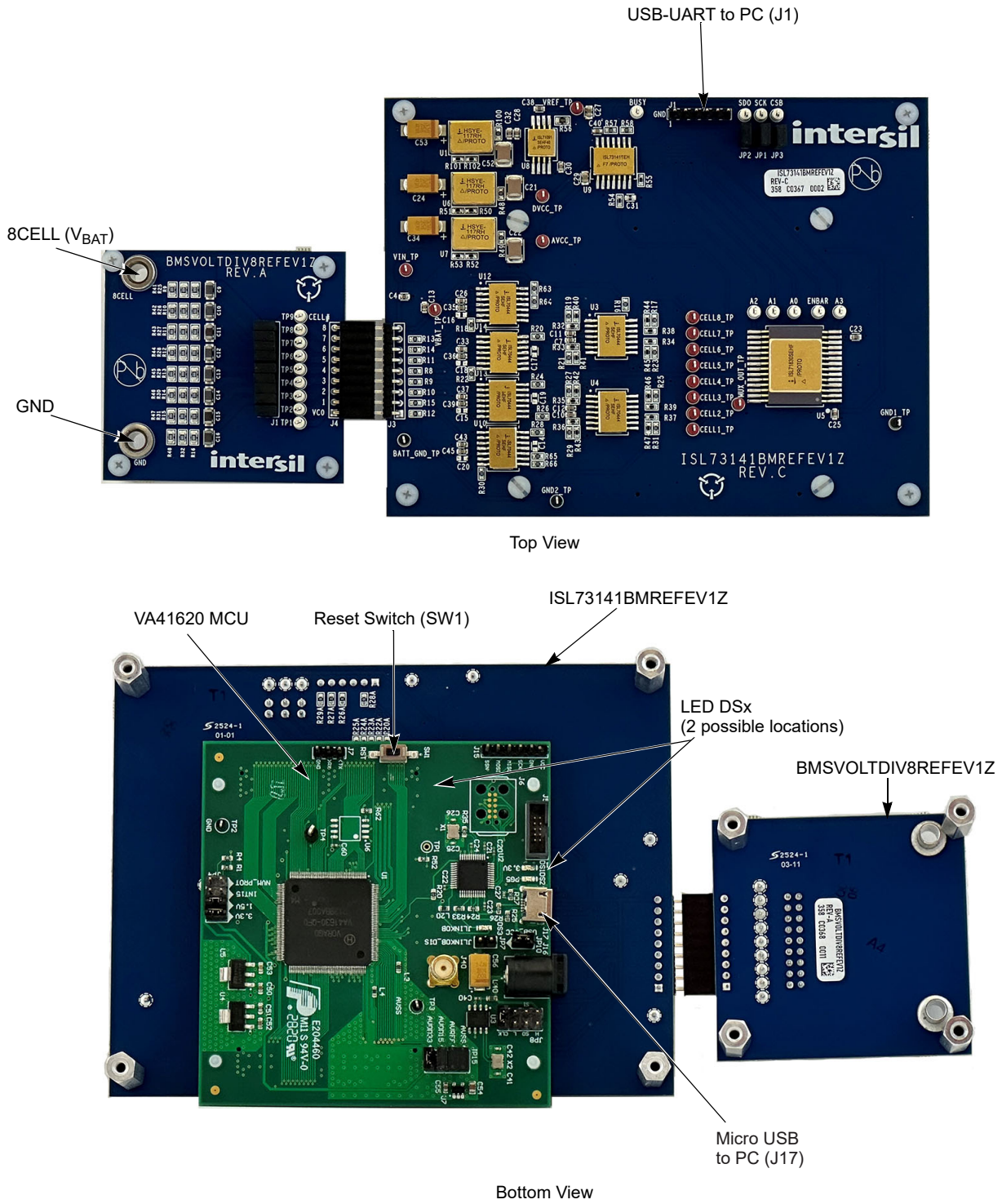

Figure 4. ISL73141BMREFEVKIT1Z Connection Diagram

1.2.1 iRADNavigator Board Selection

Double-click on the **iRADNavigator** icon from the desktop on the PC to open the **iRADNavigator** software. In the **Available Hardware** box, click to expand the list of ADC Reference designs. Select **ISL73141_Discrete_BMS** from the list and then click the **Select** button.

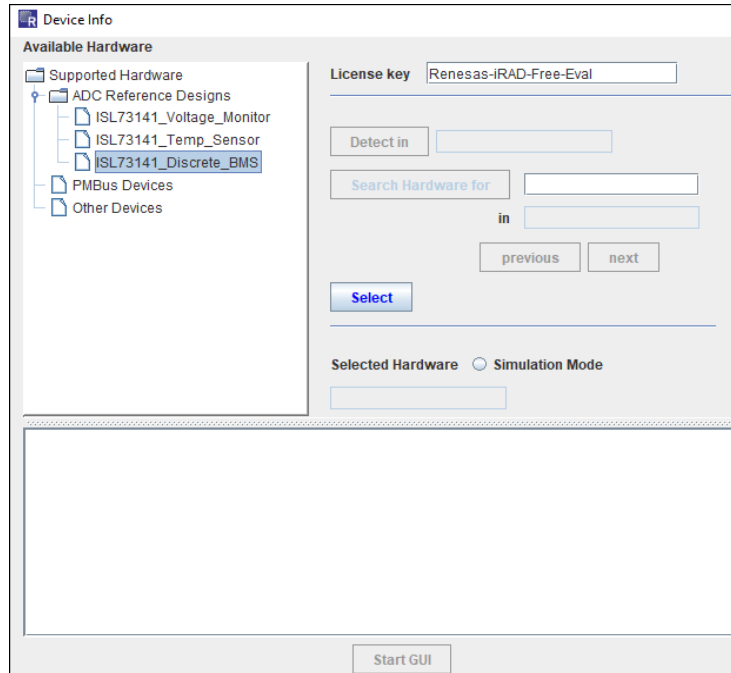

Figure 5. iRADNavigator Board Selection

After clicking **Select**, the GUI loads the screen shown in [Figure 6](#), which shows the **ISL73141_Discrete_BMS** board is selected and the available board communication options. Click **Connect** to connect the GUI to the board.

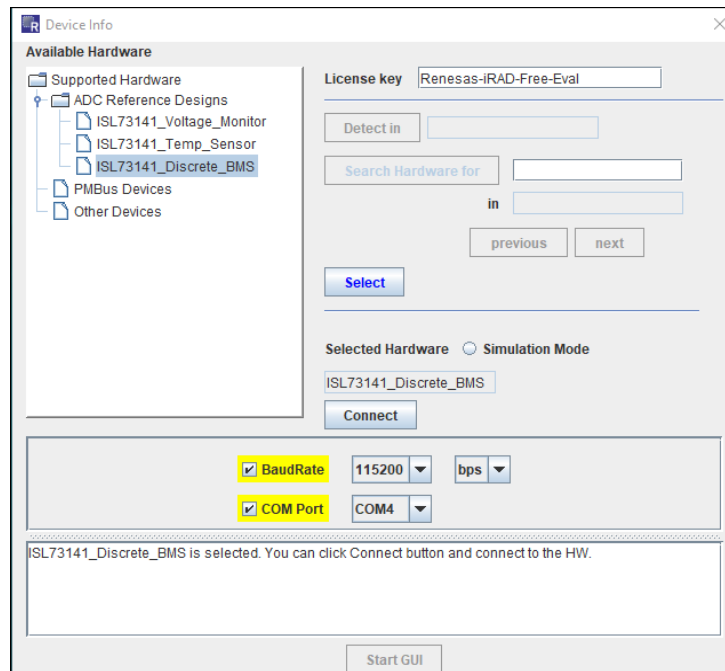

Figure 6. iRADNavigator Board Selection and Communication Options

After clicking the **Connect** button, iRADNavigator communicates with the Vorago MCU board to ensure the latest firmware is loaded into the Vorago MCU. If not, a pop-up window opens prompting the update of the firmware. If the Vorago MCU firmware is up to date, this pop-up window does not open.

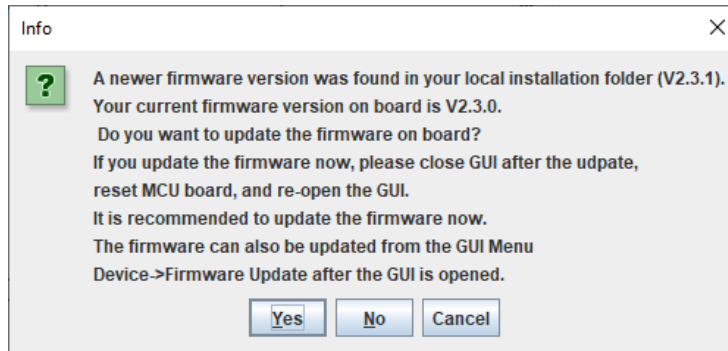

Figure 7. iRADNavigator Firmware Update Prompt

When the firmware update is complete, another pop-up window opens to state that the Vorago MCU firmware has been updated. Click **OK** to acknowledge the firmware update.



Figure 8. iRADNavigator Firmware Update Complete

After clicking **OK**, close iRADNavigator, press the reset button on the Vorago MCU board, and reopen the GUI. Select the *ISL73141_Discrete_BMS* from the selection tree and click **Connect**.

The **Start GUI** button is enabled when communication is established to the *ISL73141_Discrete_BMS* board. Click the **Start GUI** button to proceed.

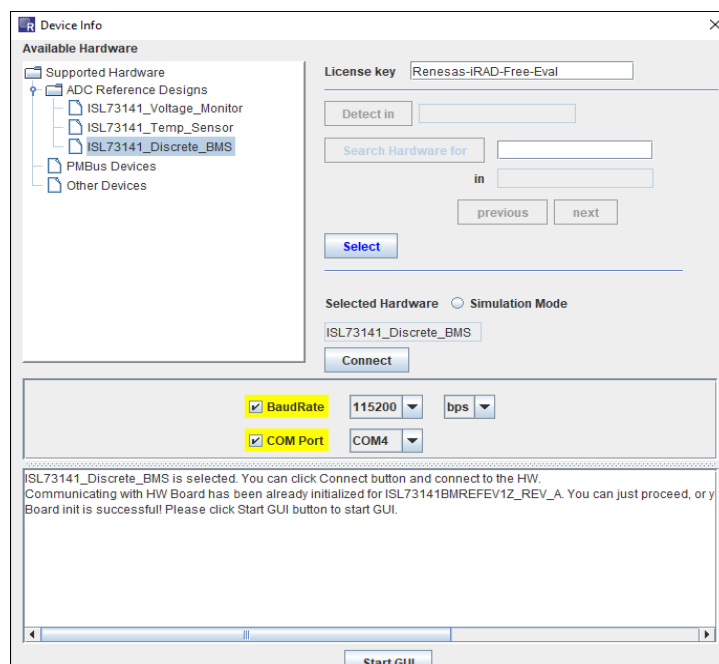

Figure 9. iRADNavigator Start GUI

1.2.2 iRADNavigator Voltage Monitor Selection and Measurements

After selecting the **Start GUI** button, the GUI window changes to allow selecting the voltages to monitor with the ISL73141BMREFEV1Z board from the BMSVOLTDIV8REFEV1Z VBAT resistor divider power board. The total Battery Voltage and the eight battery cell voltages are display on this main screen as shown in [Figure 10](#).

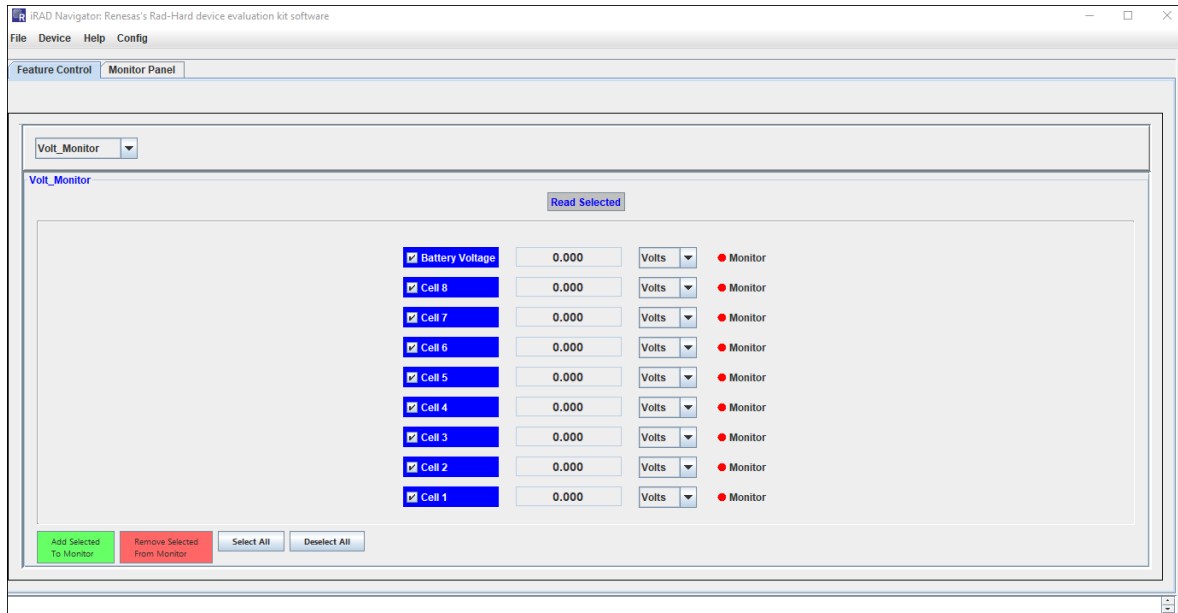

Figure 10. iRADNavigator Voltage Selection Main Screen

Apply 24V to the BMSVOLTDIV8REFEV1Z VBAT resistor divider power board. Click the **Read Selected** button to measure the total battery voltage and each of the individual cell voltages. The values should look similar to those shown in [Figure 11](#). Each time the **Read Selected** button is pressed the values should update and look similar to those shown in [Figure 11](#).

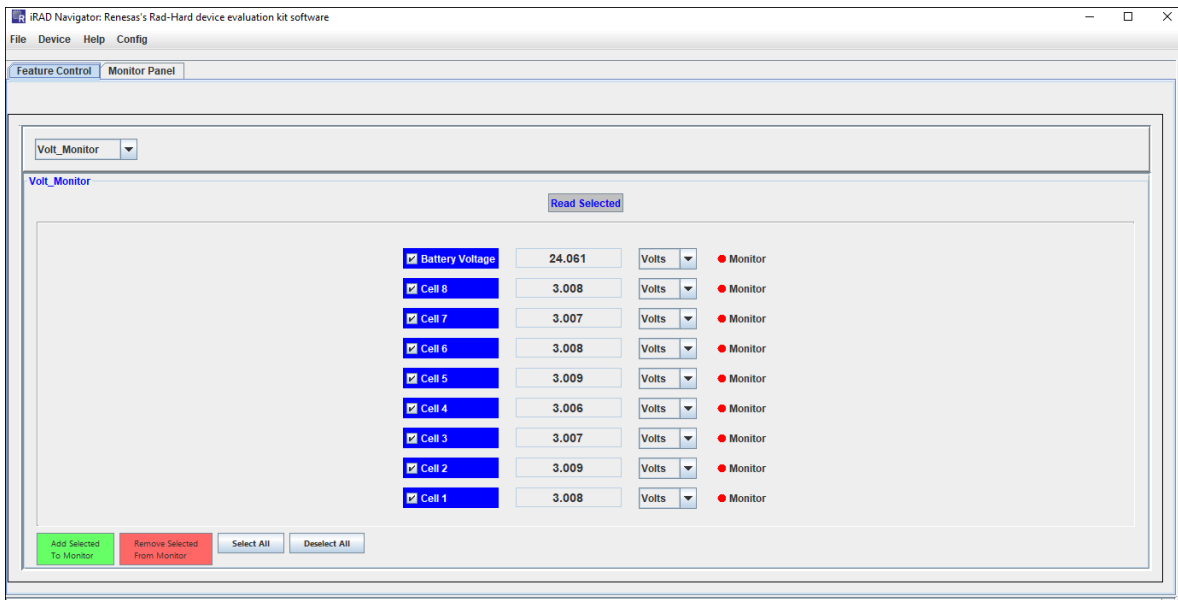

Figure 11. iRADNavigator Updated Voltage Values - Cell Voltage 3.0V

Change the battery voltage on the BMSVOLTDIV8REFEV1Z VBAT resistor divider power board to 16V. Click on the GUI **Read Selected** button and the values should look similar to those shown in [Figure 12](#). As user changes the voltage at the VBAT resistor divider power board and then clicks on the GUI **Read Selected** button, the GUI updates the total battery voltage (Battery Voltage) and each of the cell voltages (Cell 8 - Cell 1) with the new cell voltages. The reference design can handle a battery voltage in the range of 8V to 36V. Change the battery voltage on the BMSVOLTDIV8REFEV1Z VBAT resistor divider power board to 36V and click the **Read Selected** button. The cell voltages should read around 4.5V (see [Figure 13](#)).

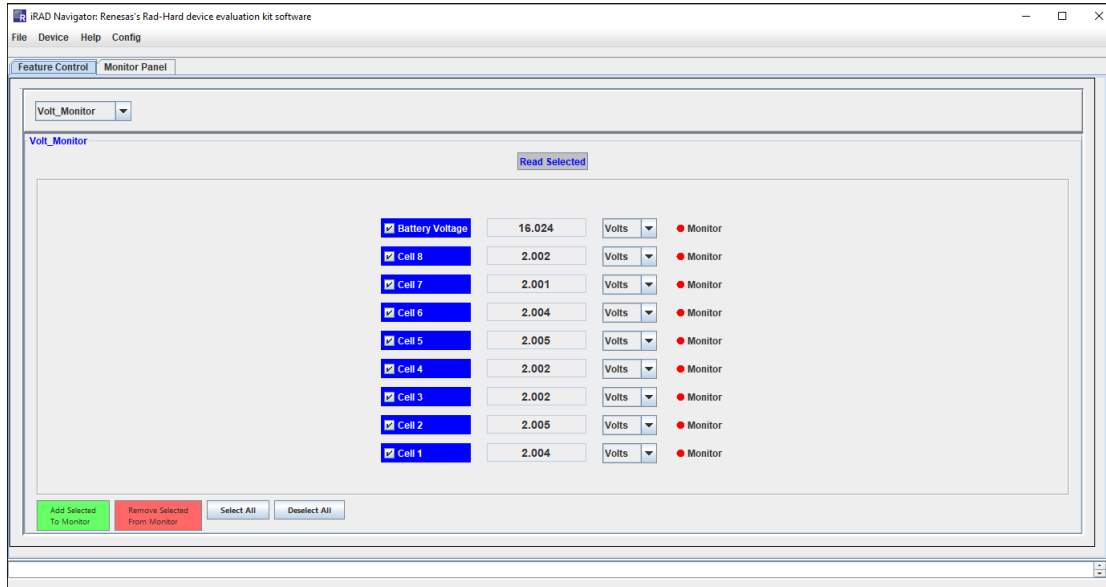

Figure 12. iRADNavigator Eight Voltages Selected for Monitor - Cell Voltage 2.0V

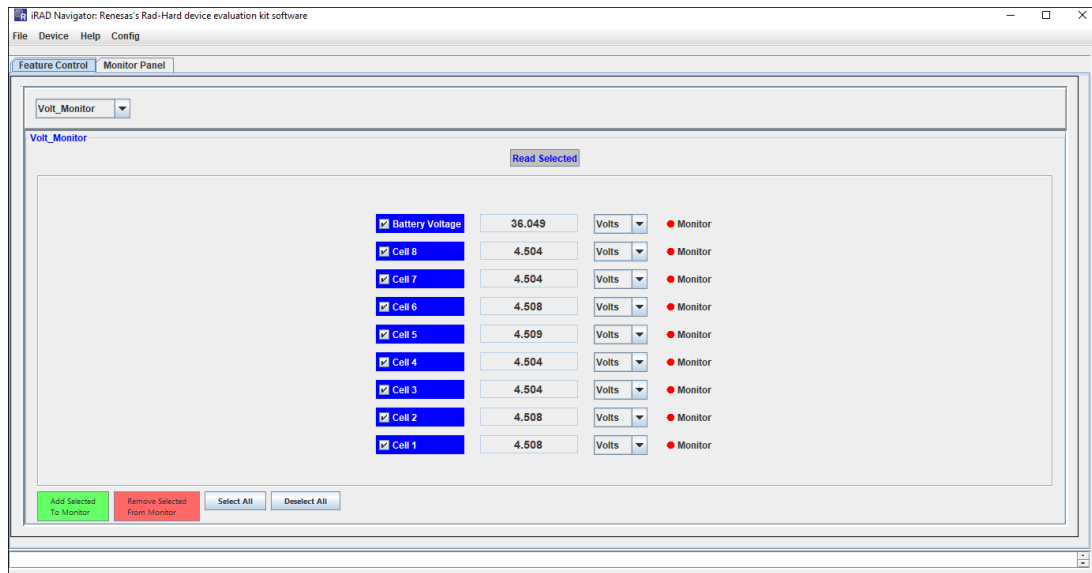

Figure 13. iRADNavigator Eight Voltages Selected for Monitor - Cell Voltage 4.5V

1.2.3 iRADNavigator Monitor Panel

Change the battery voltage on the resistor divider board to 33.6V and click on the **Read Selected** button (see [Figure 14](#)). When the GUI **Add Selected To Monitor** green button is clicked it activates the Monitor Panel and the Monitor buttons next to the (Battery Voltage) and each of the cell voltages (Cell 8 - Cell 1) beside the voltages change to green dots to indicate the selected voltages are ready for plotting in the **Monitor Panel**, see [Figure 14](#).

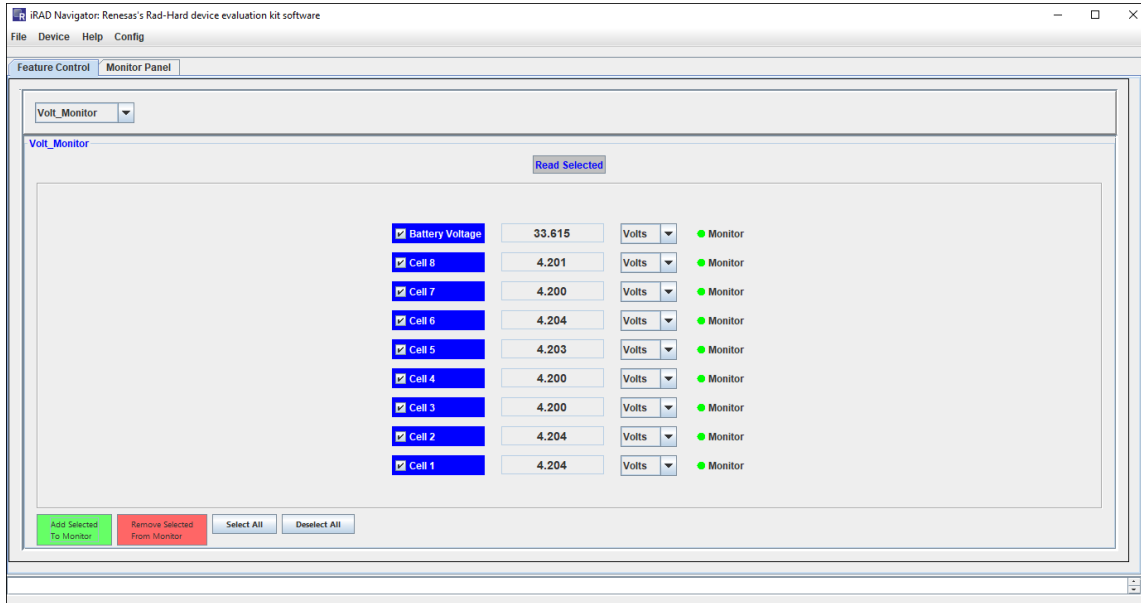

Figure 14. iRADNavigator Voltages Ready for Display in Monitor Panel - Cell Voltage 4.2V

Select the **Monitor Panel** to begin reading and displaying the voltages on this tab of iRADNavigator. The voltages begin to periodically update in this display when the **Start Monitor** button is pressed as shown in [Figure 15](#).

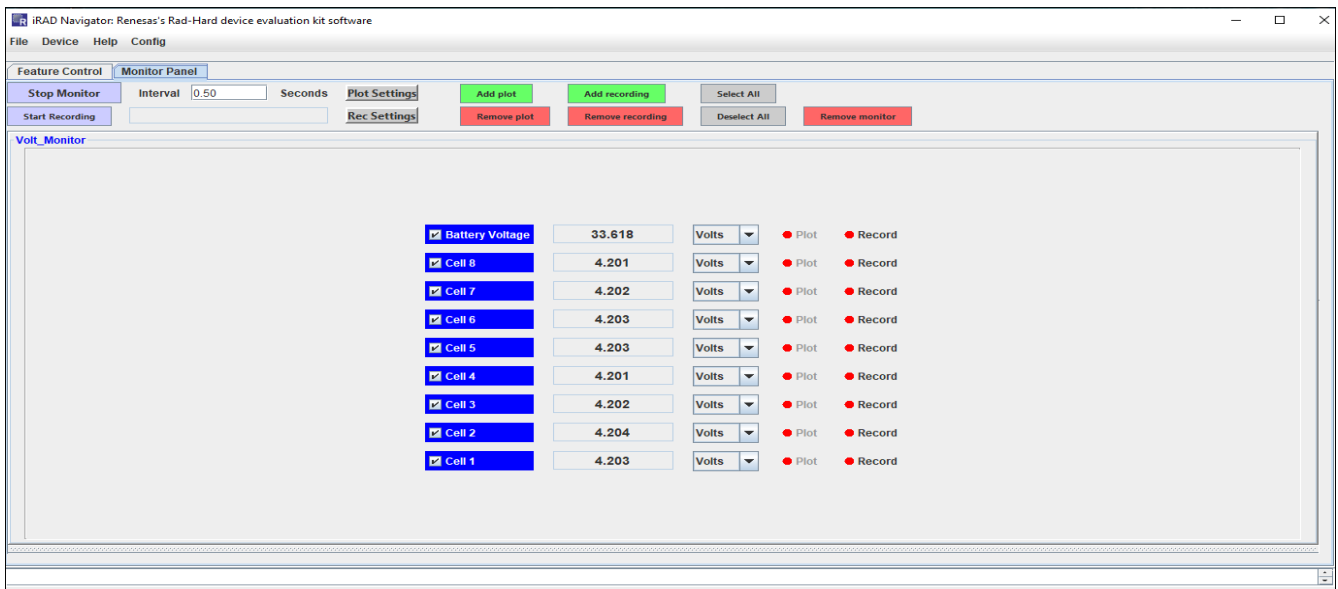

Figure 15. iRADNavigator Battery Monitoring Measurement Plot

Note: The Battery Voltage and the Cell 8 - Cell 1 plot radio buttons in this panel are red. Click the green button labeled **Add Plot**. The red dots turn green as shown in Figure 16.

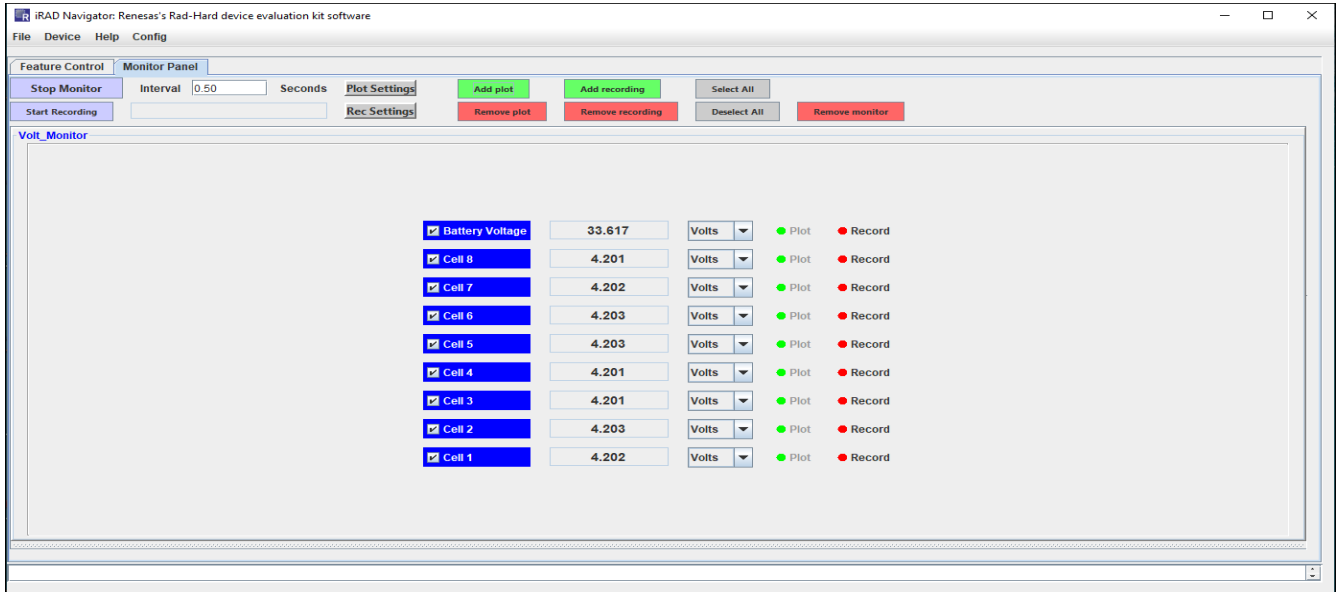

Figure 16. iRADNavigator Battery Measurement Add to Plot

The battery voltage and the individual Cell 8 - Cell 1 cell voltages can be plotted graphically in a new window by clicking the **Stop Monitor** button and then the **Start Monitor** button on the **Monitor Panel**. The iRADNavigator software initially shows plots of the Cell 8 - Cell 1 voltages and the total Battery Voltage as shown in Figure 17.

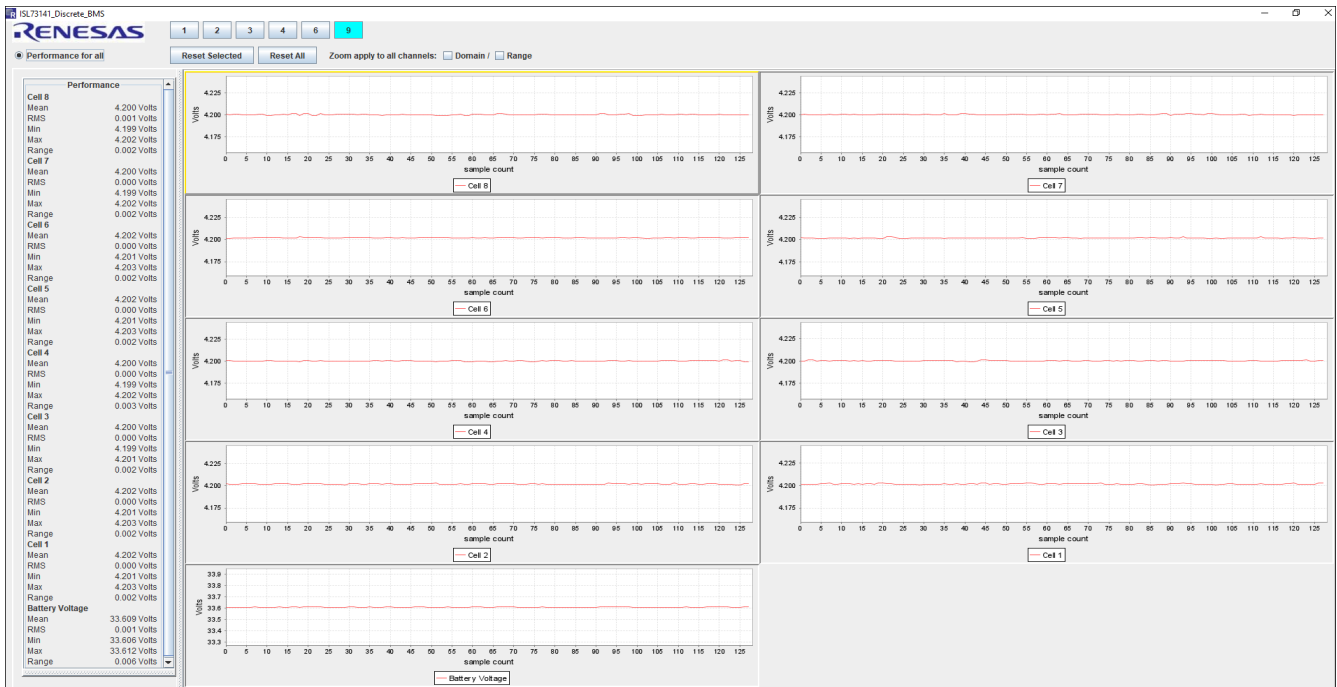

Figure 17. iRADNavigator Voltage Measurement Plot

The buttons labeled **1**, **2**, **3**, **4**, **6**, and **9** at the top of [Figure 17](#) allows choosing the number of voltage plots required to display graphically. For example, click on the button **3** and the Channel Select 3 pop-up window opens as shown in [Figure 18](#). Select **Channel 9 -Battery Voltage**, **Channel 1 -Cell 8**, and **Channel 4 -Cell 5**. After selecting these voltages, select the **OK** button. The battery voltage, Cell 8 voltage and Cell 5 voltage are graphed on the GUI in the order they were selected, see [Figure 18](#).

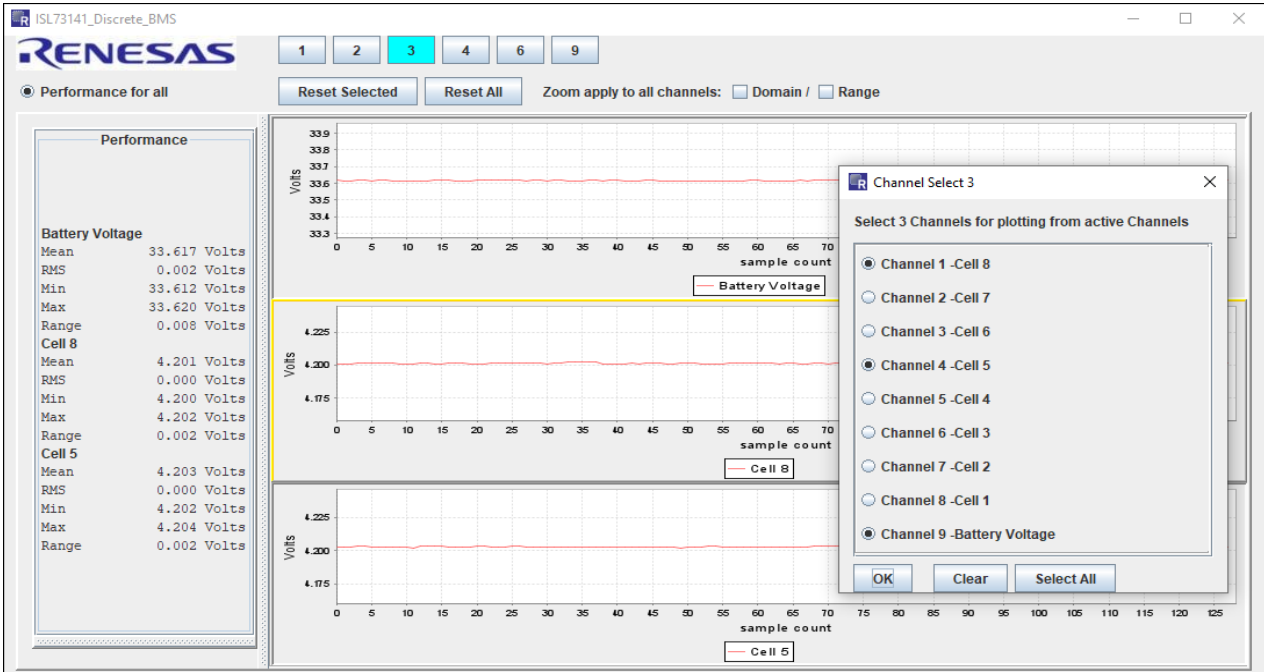

Figure 18. iRADNavigator Voltage Measurement Select Plots

To display the Battery Voltage, and the Cell Voltages 7, 5, 3, and 1 in that order, press the **6** button at top. Next, select **Channel 9 -Battery Voltage**, **Channel 2-Cell 7**, **Channel 4 -Cell 5**, **Channel 6 -Cell3**, and **Channel 8 -Cell1**. After selecting these voltages, select the **OK** button. The Battery Voltage, Cell 7, Cell 5, Cell 3, and Cell 1 Voltage are graphed on the GUI in the order they were selected, see [Figure 19](#).

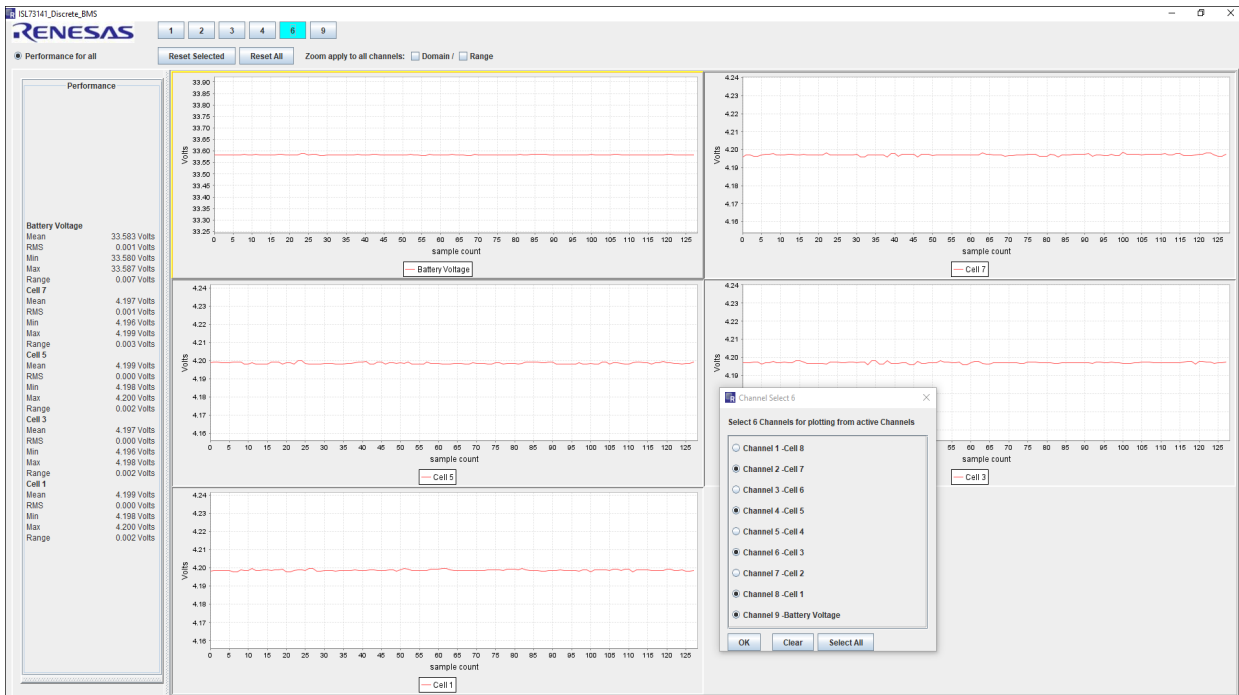

Figure 19. iRADNavigator 8 Voltage Measurement Plots

When all the required data has been observed to stop the plotting of the data, go back to the main iRADNavigator window and select the **Stop Monitor** button. This button stops the plotting of the voltage data in the plot window. After the monitor has stopped, close the plot window and the iRADNavigator window if required.

1.3 iRADNavigator MCU Firmware Update

The Vorago MCU firmware can be updated from within the iRADNavigator software GUI to ensure that the latest firmware is present in the MCU. To perform an update, select **Device** then **Firmware Update** from the menu bar.

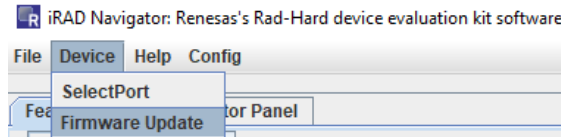

Figure 20. iRADNavigator MCU Firmware Update Selection

A pop-up window opens that can read the current firmware version, perform an online update, or perform a local update. The latest firmware should be installed along with the most recent iRADNavigator installation, but an online update might be required to have the most recent version of MCU firmware.

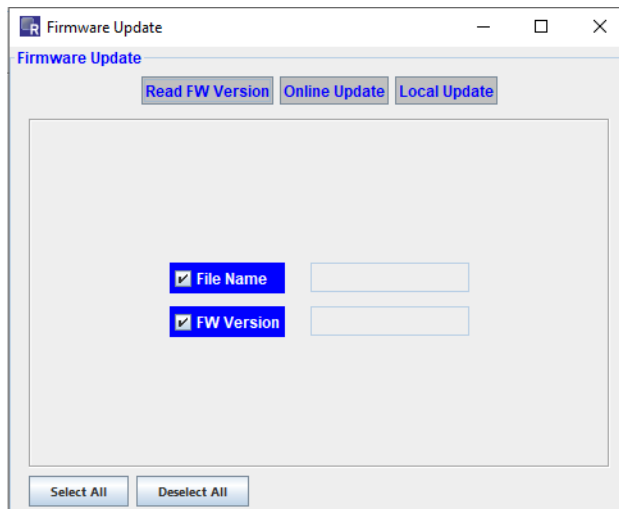

Figure 21. iRADNavigator MCU Firmware Update Action Window

If performing an online update, the GUI looks for the latest MCU firmware on the Renesas website when **Online Update** is selected. Renesas recommends using the online update; however, the firmware can be downloaded from the Renesas website and stored locally and then a local update can be performed. After selecting **Online Update**, the GUI searches for the latest firmware on the Renesas website and reports back the latest version found as shown in [Figure 22](#). Click **Yes** to proceed with updating the firmware.



Figure 22. iRADNavigator MCU Firmware Online Update

Click **Yes** to update the firmware. After the firmware is downloaded, a GUI prompt opens in a pop-up window to confirm programming the new firmware into the board. Click **Yes** again to program the firmware.

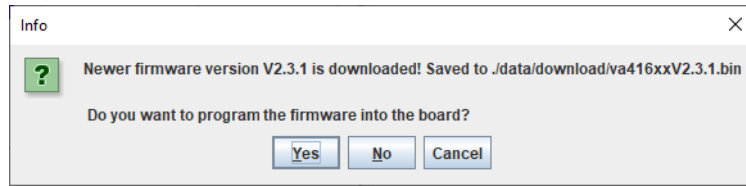

Figure 23. iRADNavigator MCU Firmware Online Update - Program Firmware

After the firmware is programmed into the board, the GUI prompts that it is complete. Click **OK** and then close the GUI, reset the MCU board, and then reopen the GUI.



Figure 24. iRADNavigator MCU Firmware Online Update - Program Firmware

When selecting Local Update, point iRADNavigator to the installation folder to find the firmware or to the folder where the firmware is stored if it was downloaded previously from the Renesas website. Figure 25 shows the typical installation path.

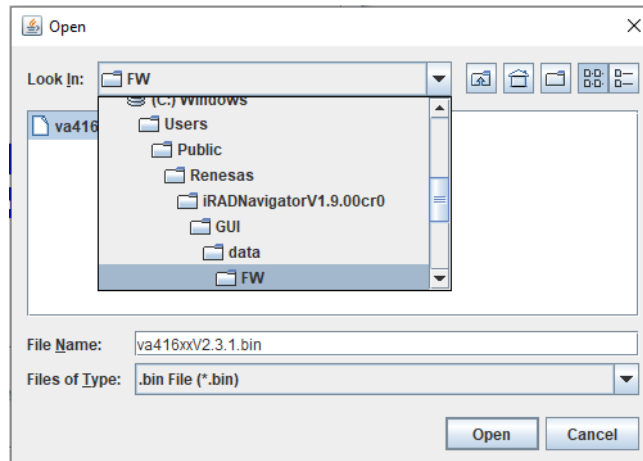

Figure 25. iRADNavigator MCU Firmware Location on Local Computer

Select the latest firmware in this location and click **Open**. Figure 26 shows the next prompt to confirm that programming the selected firmware into the MCU is required.

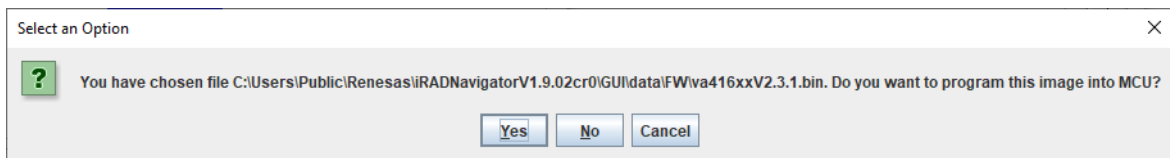

Figure 26. iRADNavigator MCU Firmware Confirmation

When the MCU firmware is installed into the MCU, the window in [Figure 27](#) opens to alert that the installation is complete. Click **OK** and then close iRADNavigator. Press the reset button on the Vorago MCU board and reopen iRADNavigator.

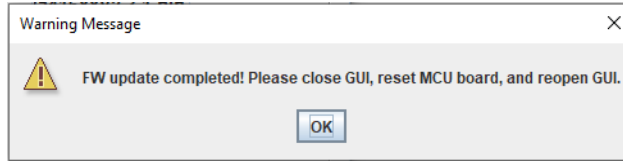

Figure 27. iRADNavigator MCU Firmware Update Complete

2. Board Design

2.1 ISL73141BMREFEV1Z Evaluation Board

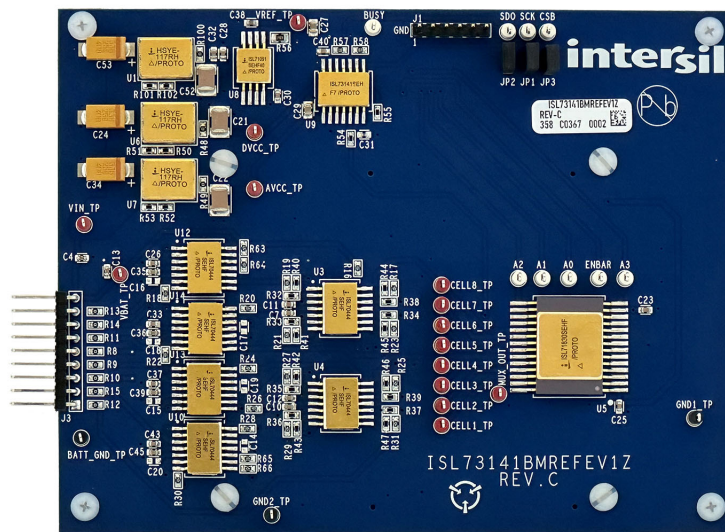

Figure 28. ISL73141BMREFEV1Z Evaluation Board (Top)

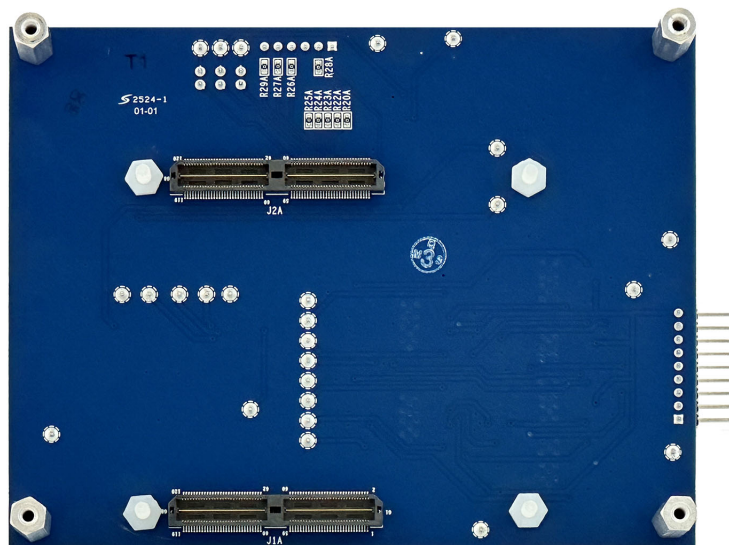

Figure 29. ISL73141BMREFEV1Z Evaluation Board (Bottom)

2.1.1 Board Schematics

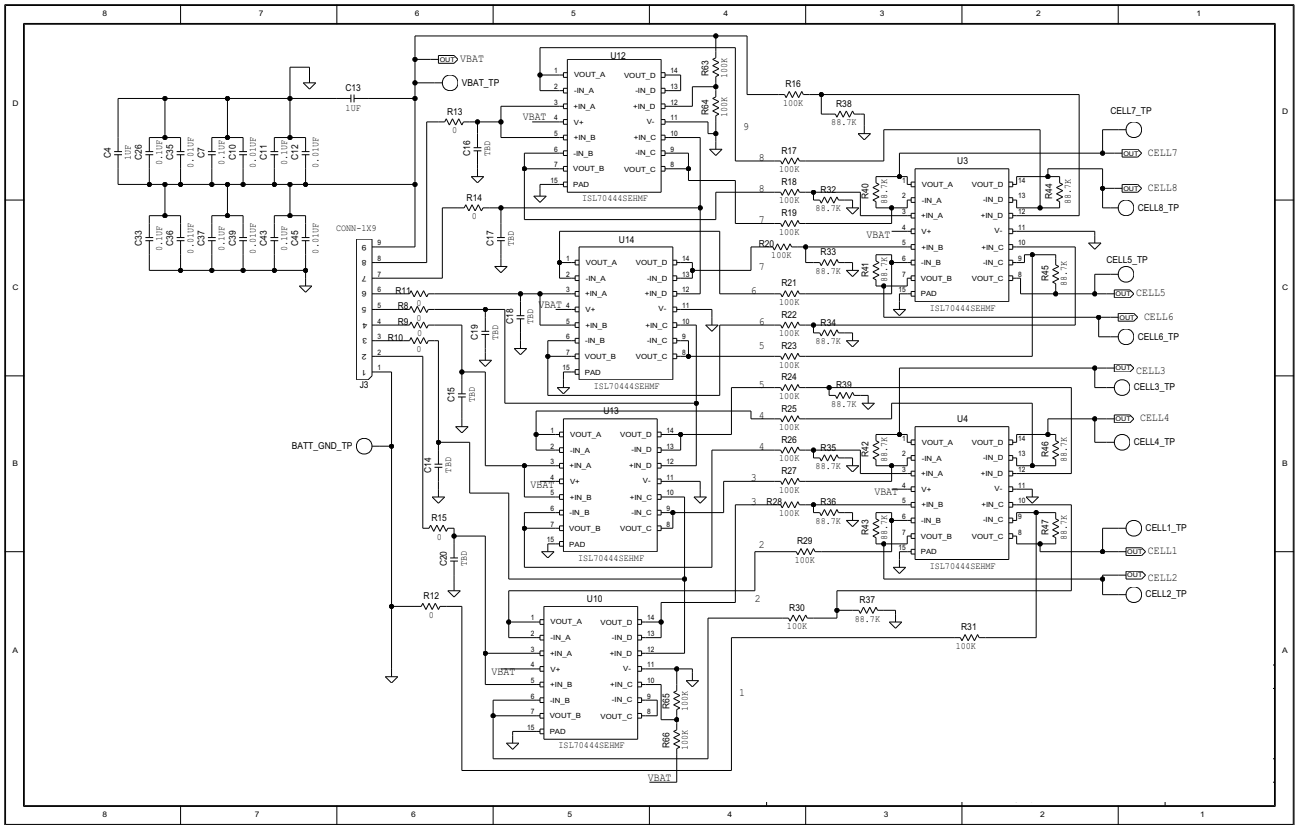

Figure 30. ISL73141BMREFEV12 Batmon Schematic Sheet 1

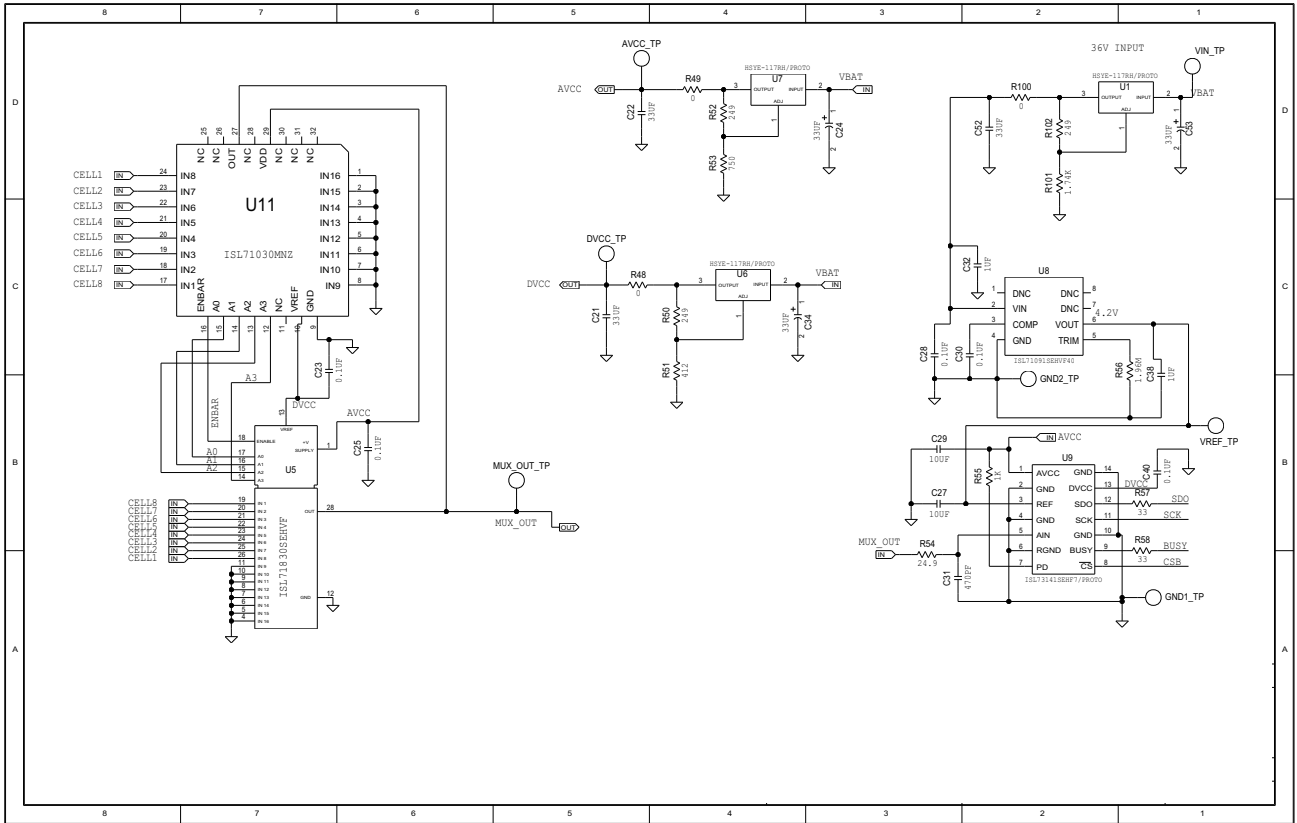

Figure 31. ISL73141BMREFEV1Z Batmon Schematic Sheet 2

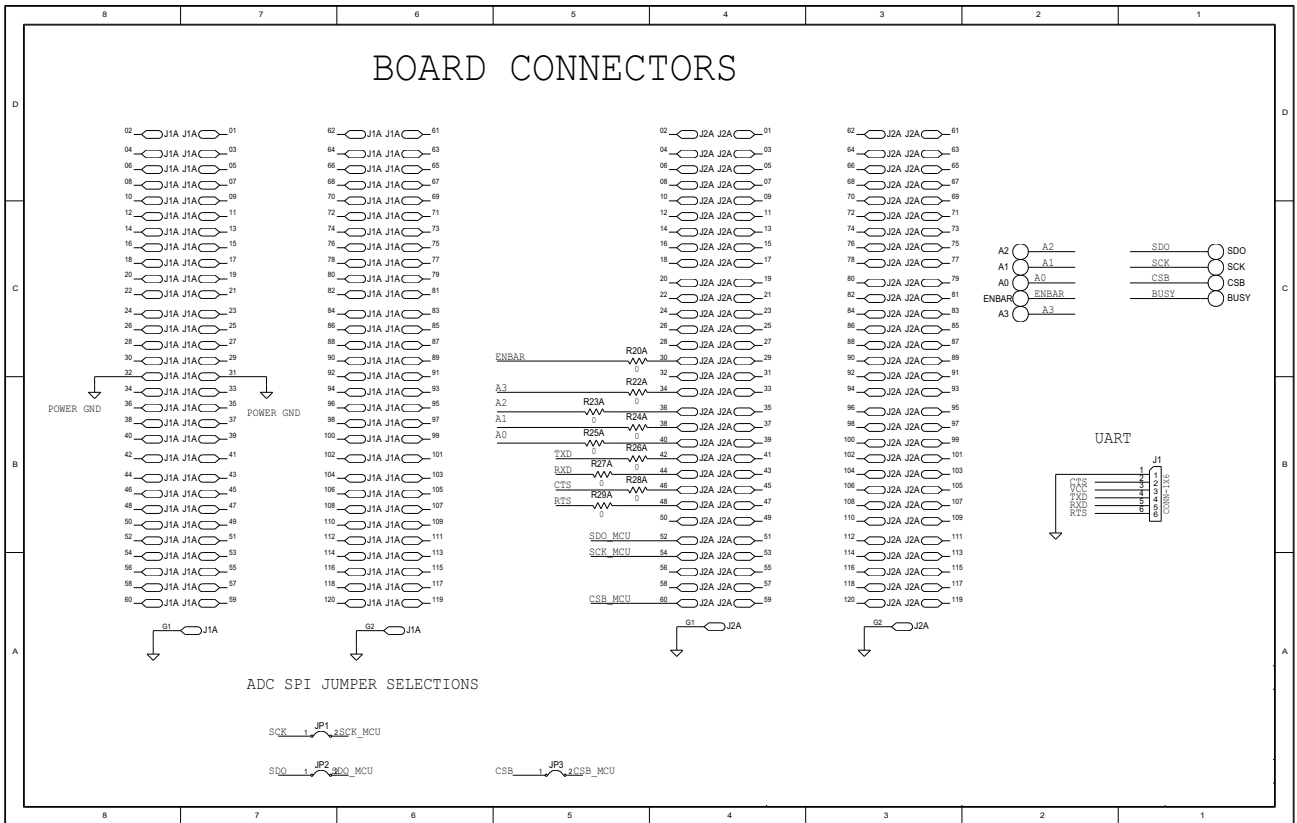

Figure 32. Board Connector Circuitry

2.1.2 Bill of Materials

Qty	Reference Designator	Description	Manufacturer	Manufacturer Part
1	-	PWB-PCB, ISL73141BMREFEV1Z, REVC, ROHS	Imagineering Inc	ISL73141BMREFEV1ZREVCPCB
14	AVCC_TP, CELL1_TP - CELL8_TP, DVCC, MUX_OUT_TP, VBAT_TP, VIN_TP, VREF_TP	Miniature Red Test Point 0.100 Pad 0.040 Thole	Keystone	5000
3	BATT_GND_TP, GND1_TP, GND2_TP	Miniature Black Test Point 0.100 Pad 0.040 Thole	Keystone	5001
9	Ao-A3, BUSY, CSB, ENBAR, SCK, SDO	Miniature White Test Point 0.100 Pad 0.040 Thole	Keystone	5002
1	J3	Male Inline 8 pins×1 inch Connector Strip	Molex	22-28-8091
3	C21, C22, C52	Multilayer Cap	TDK	C4532X7R1C336M250KC
1	J1	Male Inline 6 pins×0.1 inch Connector Strip	Amphenol	68000-106HLF
1	R56	Thin Film Chip Resistor	TE Connectivity	CPF0805B1M96E
2	R57, R58	Moisture Resistant Thick Film Resistor	TE Connectivity	CRGCQ0603F33R
3	C24, C34, C53	Solid Elect Tant Cap	Panasonic	EEJL1ED336R
16	R32-R47	Thin Film Chip Resistor	Panasonic	ERA=3AEB8872V
4	C4, C13, C32, C38	Ceramic Chip Cap	Murata	GRM188R71E105KA12
2	C27, C29	Ceramic Chip Cap	Murata	GRM21BR61E106MA73
6	C10, C12, C35, C36, C39, C45	Multilayer Cap	Murata	GRM188R71H103KA01D
11	C7, C11, C23, C25, C26, C28, C30, C33, C37, C40, C43	Multilayer Cap	TDK	C1608X7R1H104K
1	C31	Multilayer Cap	AVX	04025A471KAT2A
20	R16-R31, R63-R66	Metal Film Chip Resistor	Panasonic	ERA-3AEB8872V
20	R8-R15, R20A, R22A- R29A. R48, R49, R100	Thick Film Chip Resistor	Generic	CR0603-10W-000T
1	R55	Thick Film Chip Resistor	Panasonic	ERJ-3EKF1001V
1	R101	Thick Film Chip Resistor	Panasonic	ERJ-3EKF1741V

Qty	Reference Designator	Description	Manufacturer	Manufacturer Part
3	R50, R52, R102	Thick Film Chip Resistor	Panasonic	ERJ-3EKF2490V
1	R54	Thick Film Chip Resistor	Panasonic	ERJ-3EKF24R9V
1	R51	Thick Film Chip Resistor	Panasonic	ERJ-3EKF4120V
1	R53	Thick Film Chip Resistor	Panasonic	ERJ-3EKF7500V
3	U1,U6, U7	Radiation Hardened Adjustable Positive Regulator	Renesas Electronics America	HSYE-117RH/PROTO
6	U3,U4,U10,U12, U13,U14	Radiation Hardened 40V Quad Rail-Rail Input-Output Operational Amplifier	Renesas Electronics America	ISL70444SEHF/PROTO
1	U5	Radiation Hardened 5V 16-Channel Analog Multiplexer	Renesas Electronics America	ISL71830SEHF/PROTO
1	U8	4.096V Rad-Hard Ultra Low Noise Precision Voltage Reference	Renesas Electronics America	ISL71091SEHVF40/PROTO
1	U9	RAD Hard Single Channel 14-Bit 1MSPS SAR ADC Converter	Renesas Electronics America	ISL73141SEHVF7/PROTO
3	JP1-JP3	100 mil Spacing Two Pin Jumper	Generic	JUMPER2_100
2	J1A, J2A	120 pin QTH Series Connector	Samtec	QTH-060-01-F-D-A
1	-	40-Pin Ribbon Cable, Socket to Socket, 0.100" Pitch	Samtec	IDSD-20-D-24.00
4	JP1, JP2, JP3, JP4	CONN-Jumper, Shunt, 2P, 2.54mm Pitch, BLK, 6mm, OPEN, ROHS	Sullins	SPC02SYAN
4	-	STANDOFF,4-40×3/4in, F/F, HEX,ALUMINUM,1/4in.OD, ROHS	McMaster-Carr	91780A165
4	-	SCREW,4-40×1/4in, PANHEAD, NYLON,PHILLIPS,ROHS	McMaster-Carr	94735A717
4	-	SCREW,4-40×7/16in,PANHEAD SLOTTED,NYLON,PHILLIPS,ROHS	Essentra Components	010440P043
4	-	HEX NUT,4-40×1/4in, 0.100in HEIGHT	Essentra Components	0400440HN

2.1.3 Board Layout

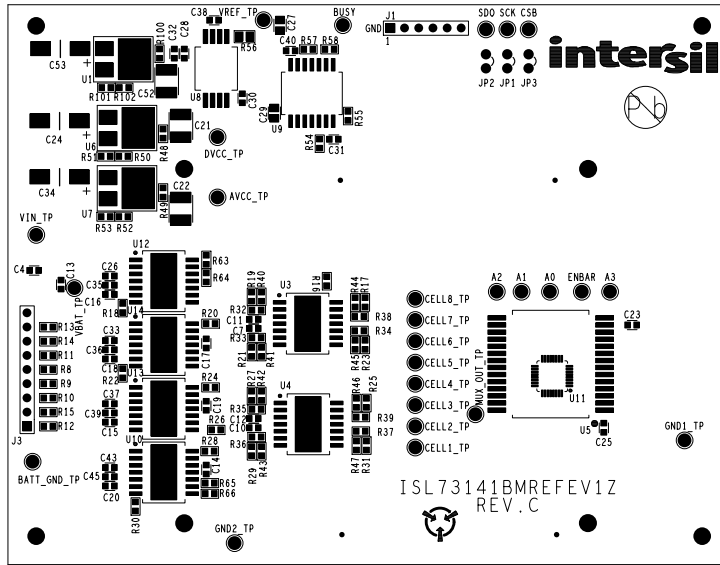

Figure 33. Top Layer Silk Screen

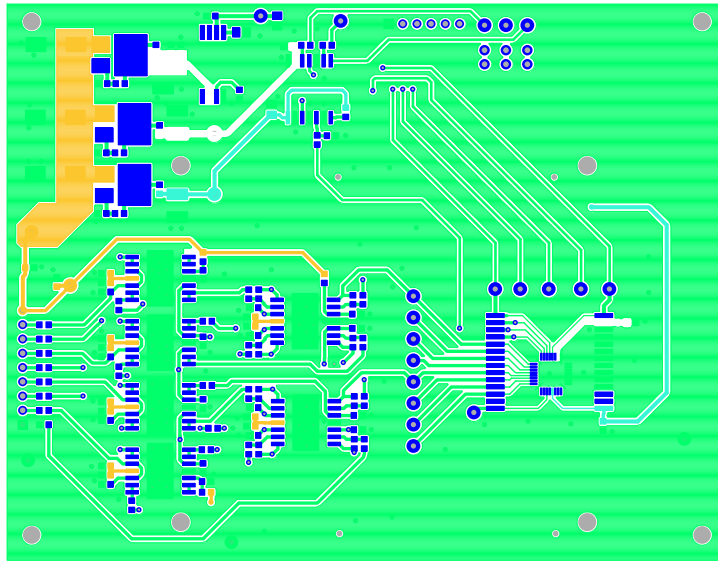

Figure 34. Top Layer

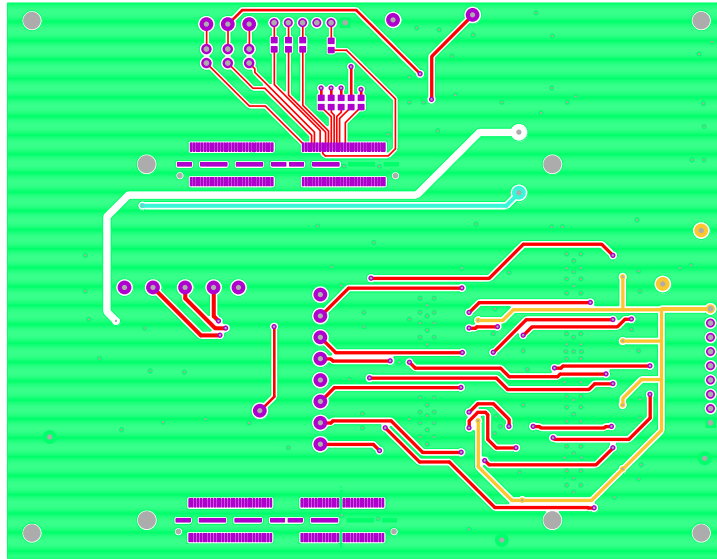

Figure 35. Bottom Layer

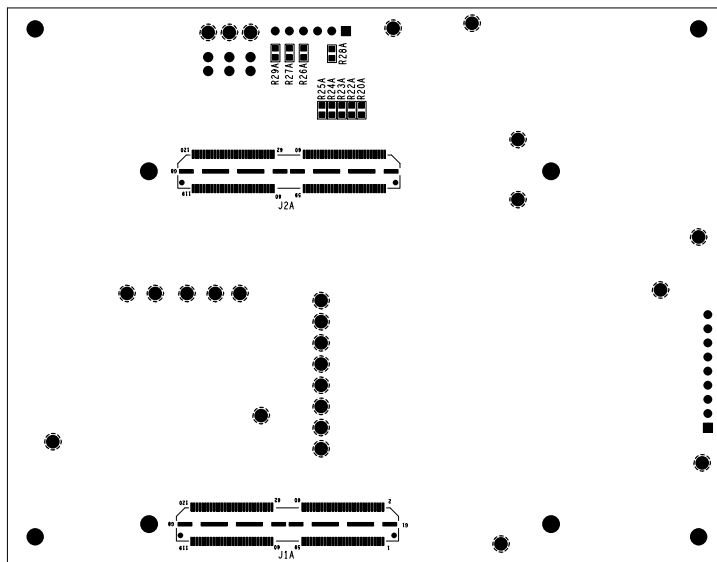

Figure 36. Bottom Layer Silk Screen

2.2 BMSVOLTDIV8REFEV1Z Resistor Divider Power Board

2.2.1 Board Schematics

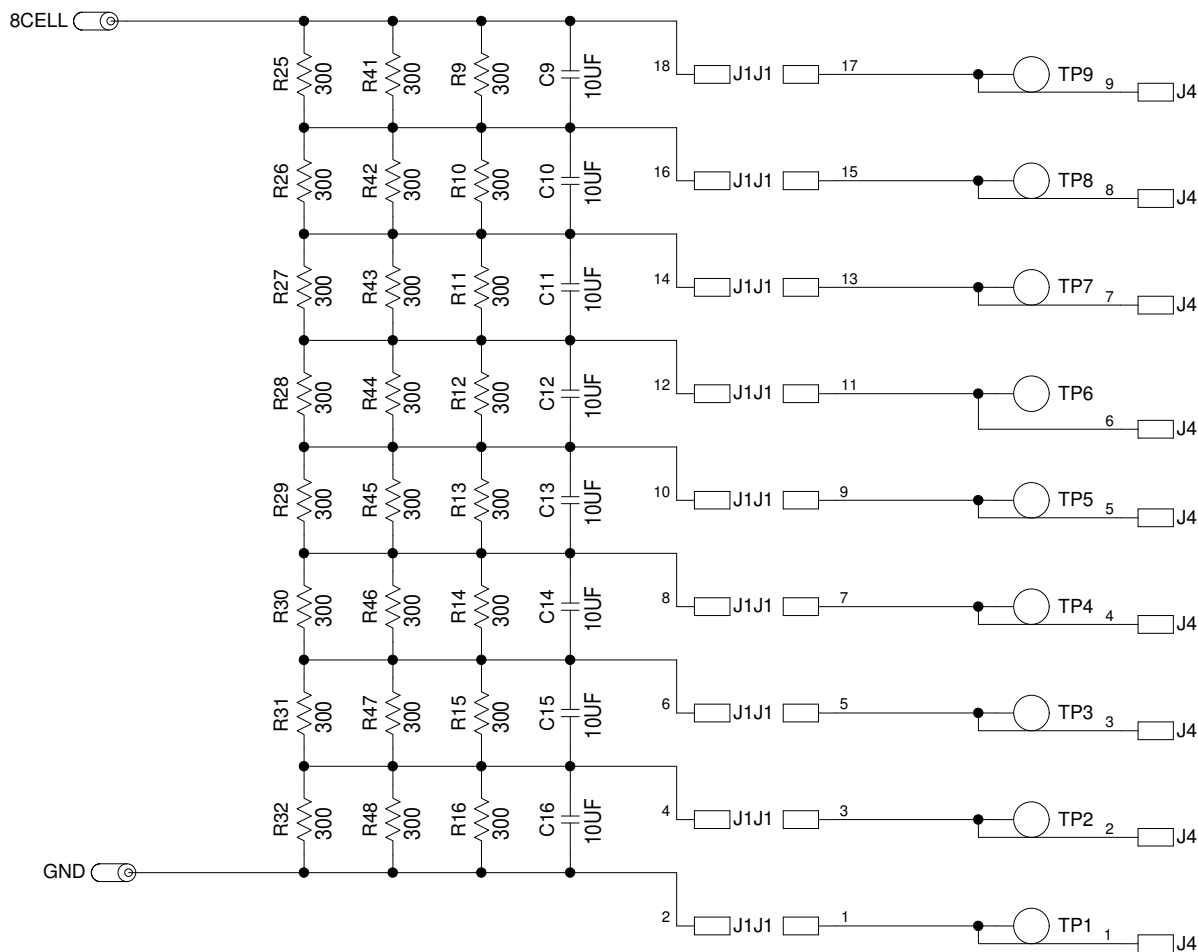

Figure 37. BMSVOLTDIV8REFEV1Z Schematic

2.2.2 Bill of Materials

Qty	Designator	Description	Manufacturer	Part Number
2	8CELL,GND	CONN CON_BAN_575 Keystone L = 0.350in Solder Mount Banana Plug	Keystone	575-8
8	C9, C10, C11, C12, C13, C14, C15, C16	10µF 10% 25V 1206 CAP_1206 Kemet Multilayer Cap	Kemet	C1206C106K3RAC7800
1	J1	18 CON_HDR_90151-2×18 Molex Female Dual Row Vertical PCB Connector	Molex	901310769
1	J4	9 CONN-1×9 Sullins Female In-line 9 pins × 0.1 inch Right Angle Receptacle Strip	Sullins	PPPC091LGBN-RC
4	N/A - Place in 4 corner holes	McMaster-Carr Standoff,4-40×3/4in, F/F, Hex, Aluminum,1/4in.OD,RoHS	McMaster-Carr	91780A165
4	N/A - Place in 4 corner holes	McMaster-Carr Screw, 4-40×1/4in, PANHEAD, Nylon, Phillips, RoHS	McMaster-Carr	94735A717

Qty	Designator	Description	Manufacturer	Part Number
24	R9, R10, R11, R12, R13, R14, R15, R16, R25, R26, R27, R28, R29, R30, R31, R32, R41, R42, R43, R44, R45, R46, R47, R48	300 0.1% 1/10W 805 RES_0805 Panasonic Thick Film Chip Resistor	Panasonic	ERJ-PB6B3000V
9	TP1, TP2, TP3, TP4, TP5, TP6, TP7, TP8, TP9	THOLE MTP500X Keystone Miniature White Test Point 0.100 Pad 0.040 Thole	Keystone	5002

2.2.3 Board Layout

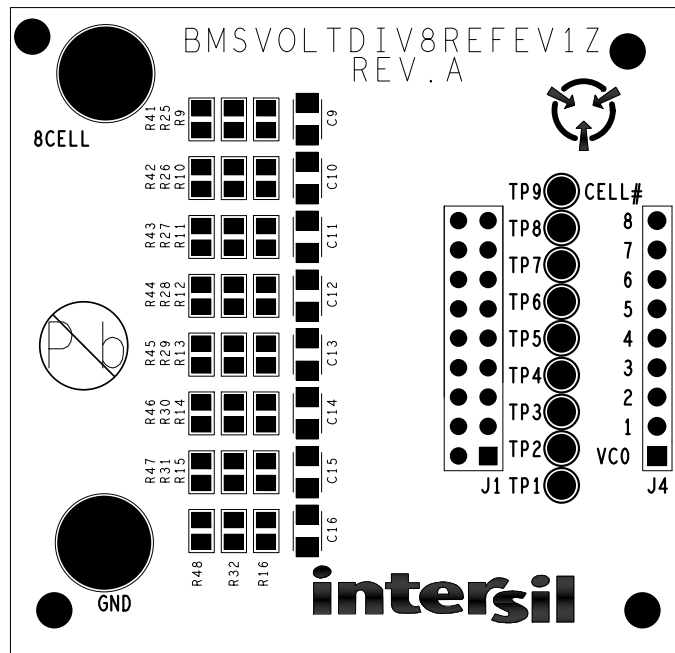

Figure 38. Top Layer

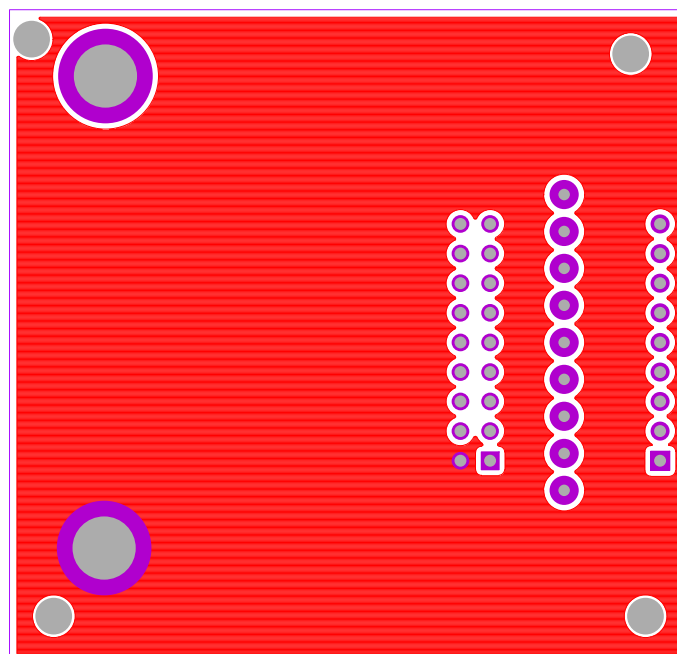

Figure 39. Bottom Layer

3. Ordering Information

Part Number	Description
ISL73141BMREFEVKIT1Z	ISL73141SEH ADC Battery Monitor Reference Design Complete Kit
ISL73141BMREFEVKIT2Z	ISL73141VMREFEV1Z ADC Battery Monitor Reference Design Partial Kit (Includes only ISL73141BMREFEV1Z and BMSVOLTDIV8REFEV1Z boards)

4. Revision History

Revision	Date	Description
1.00	Nov 8, 2024	Initial release

IMPORTANT NOTICE AND DISCLAIMER

RENESAS ELECTRONICS CORPORATION AND ITS SUBSIDIARIES (“RENESAS”) PROVIDES TECHNICAL SPECIFICATIONS AND RELIABILITY DATA (INCLUDING DATASHEETS), DESIGN RESOURCES (INCLUDING REFERENCE DESIGNS), APPLICATION OR OTHER DESIGN ADVICE, WEB TOOLS, SAFETY INFORMATION, AND OTHER RESOURCES “AS IS” AND WITH ALL FAULTS, AND DISCLAIMS ALL WARRANTIES, EXPRESS OR IMPLIED, INCLUDING, WITHOUT LIMITATION, ANY IMPLIED WARRANTIES OF MERCHANTABILITY, FITNESS FOR A PARTICULAR PURPOSE, OR NON-INFRINGEMENT OF THIRD-PARTY INTELLECTUAL PROPERTY RIGHTS.

These resources are intended for developers who are designing with Renesas products. You are solely responsible for (1) selecting the appropriate products for your application, (2) designing, validating, and testing your application, and (3) ensuring your application meets applicable standards, and any other safety, security, or other requirements. These resources are subject to change without notice. Renesas grants you permission to use these resources only to develop an application that uses Renesas products. Other reproduction or use of these resources is strictly prohibited. No license is granted to any other Renesas intellectual property or to any third-party intellectual property. Renesas disclaims responsibility for, and you will fully indemnify Renesas and its representatives against, any claims, damages, costs, losses, or liabilities arising from your use of these resources. Renesas' products are provided only subject to Renesas' Terms and Conditions of Sale or other applicable terms agreed to in writing. No use of any Renesas resources expands or otherwise alters any applicable warranties or warranty disclaimers for these products.

(Disclaimer Rev.1.01 Jan 2024)

Corporate Headquarters

TOYOSU FORESIA, 3-2-24 Toyosu,
Koto-ku, Tokyo 135-0061, Japan
www.renesas.com

Trademarks

Renesas and the Renesas logo are trademarks of Renesas Electronics Corporation. All trademarks and registered trademarks are the property of their respective owners.

Contact Information

For further information on a product, technology, the most up-to-date version of a document, or your nearest sales office, please visit www.renesas.com/contact-us/.