

ISL71840SEHEV1Z

Evaluation Board

UG028  
Rev.0.00  
April 16, 2015

**Description**

The [ISL71840SEH](#) is a radiation hardened, 16-channel high ESD protected multiplexer that is fabricated using Intersil's proprietary P6SOI (Silicon On Insulator) process technology to mitigate single-event effects and total ionizing dose. It operates with a dual supply voltage ranging from  $\pm 10.8V$  to  $\pm 16.5V$ . "This evaluation board is designed to provide easy access to the capabilities of the part."

The evaluation board has a DIP switch, which provides a convenient way to address all 16 channels without the need for extra supplies. There's also a BNC input available that will allow you to drive the address pins with a signal generator.

**Specifications**

This board has been configured and optimized for the following operating conditions:

- $V_+ = +10.8V$  to  $+16.5V$
- $V_- = -10.8V$  to  $-16.5V$
- $V_{REF} = 4.5V$  to  $5.5V$

**Key Features**

- Jumper selectable input source for each input
- DIP switch to conveniently select 1 of 16 channels
- BNC input for dynamic addressing
- Multiple loading options with jumpers on VOUT
- Convenient power connection
- On-board enable switch

**References**

[ISL71840SEH](#) Datasheet

**Ordering Information**

PART NUMBER	DESCRIPTION
ISL71840SEHEV1Z	Evaluation board for the ISL71840SEH

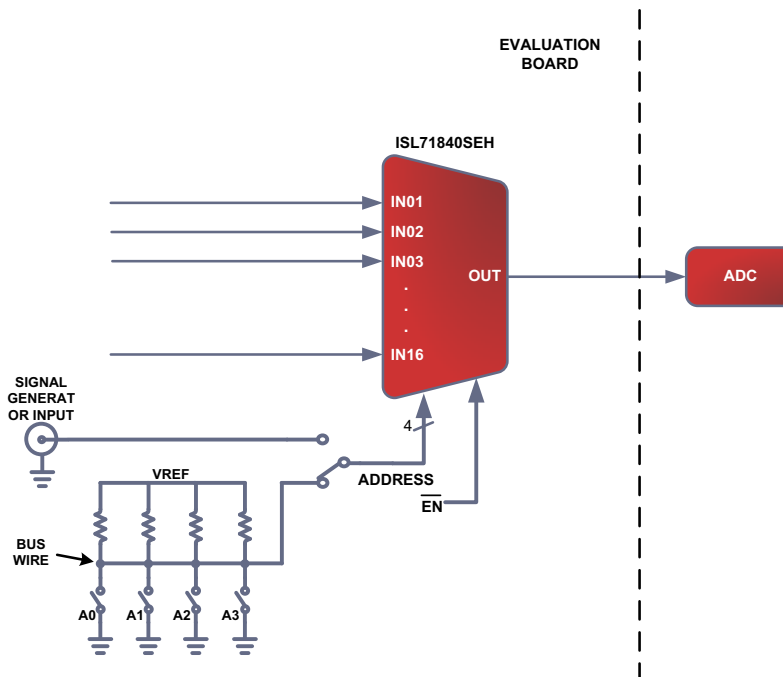

FIGURE 1. ISL71840SEHEV1Z BLOCK DIAGRAM

## ISL71840SEHEV1Z Evaluation Board

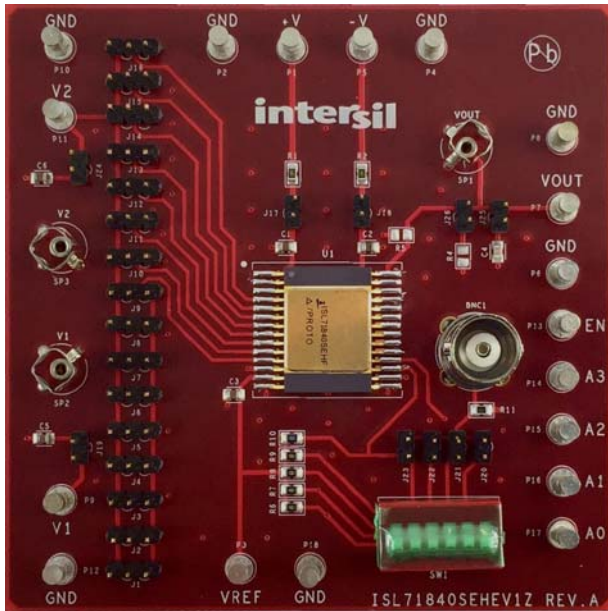

FIGURE 2. TOP SIDE



FIGURE 3. BOTTOM SIDE

### Power Supplies

This board has power supply inputs for V+, V- and VREF. There's no requirements for sequencing on these supplies, but it is recommended that the supplies come up relatively at the same time. In-line resistors are provided to V+ and V- with decoupling capacitors close to the part for V+, V- and VREF. The in-line resistors are 100Ω but can be changed by the user for additional power supply filtering or to limit the rise time of the supply voltages.

The voltage ranges for V+ is +10.8V to +16.5V and the range for V- is -10.8V to -16.5V. VREF ranges from 4.5V to 5.5V. The ISL71840SEH is a rail-to-rail mux and should be able to accommodate any input signal with a voltage level between or equal to the supplies voltages. VREF is used to set the decoder logic levels.

### PCB Layout Guidelines

The ISL71840SEHEV1Z PCB layout has been optimized for ease of testing. When incorporating the ISL71840SEH into a system there are a few guidelines that can ensure optimal electrical and noise performance.

- Analog circuits can conduct noise through paths that connect it to the “outside world”. These paths include the V+, V-, VREF, input to any switch and the output. It is important to make sure these paths are kept away from known noise sources.
- It is recommended to decouple the power supply pins (V+, V- and VREF) for power supply filtering. If the traces to the supply lines are long, it is recommended to use a larger 1μF capacitor at the point of entry for the supply and a smaller capacitor, like a 0.1μF, close to the part to reduce high frequency perturbations.

# ISL71840SEHEV1Z Circuit Schematic

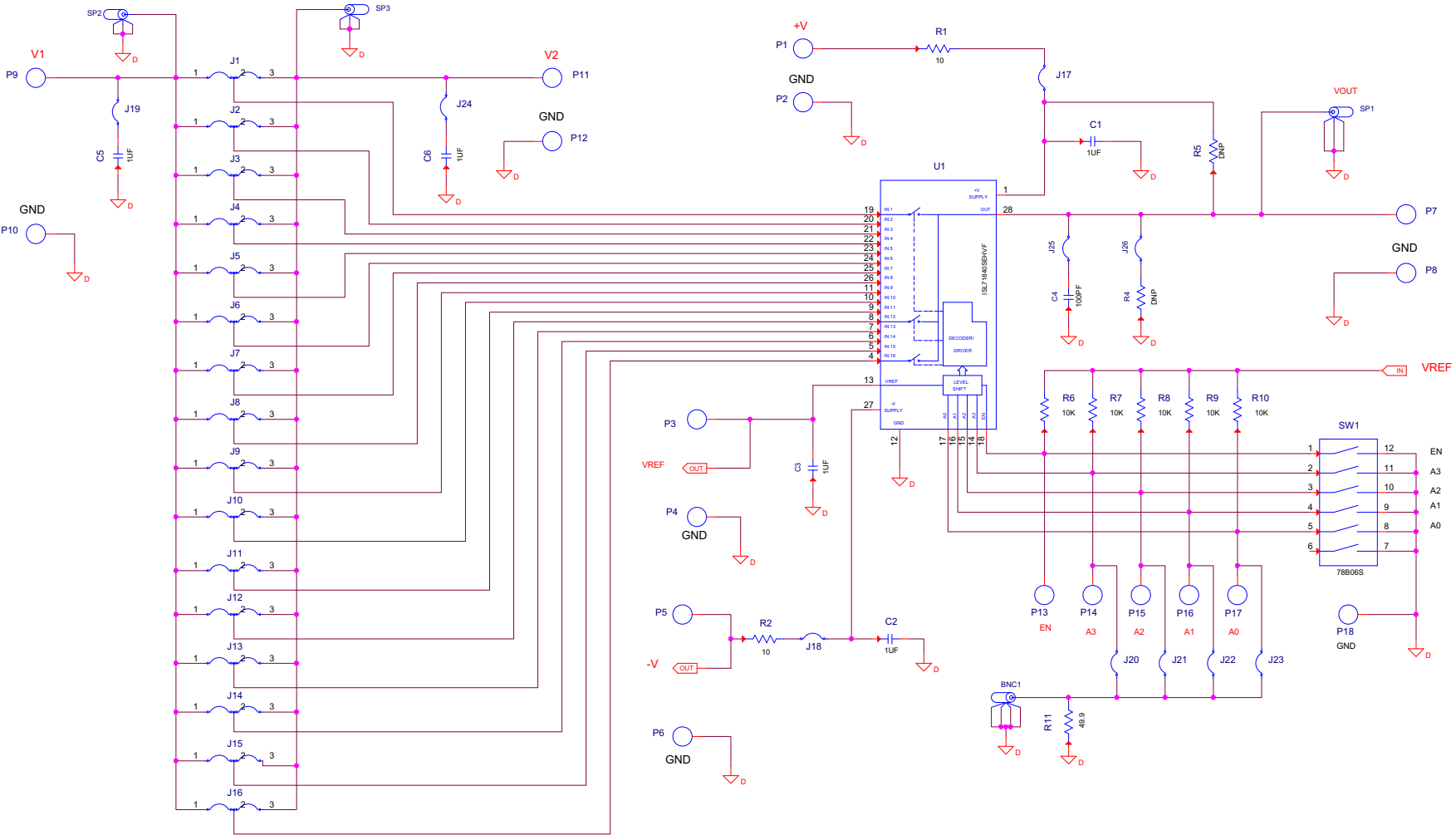

FIGURE 4. ISL71840SEHEV1Z SCHEMATIC

## Bill of Materials

ITEM	QTY	REFERENCE DESIGNATOR	VALUE	TOL (%)	RATING	TYPE	PCB FOOTPRINT	MANUFACTURER	MANUFACTURER PART NUMBER
1	1	C4	100pF	5	50V	X7R	0805	PANASONIC	ECU-V1H101JCG
2	5	C1, C2, C3, C5, C6	1µF	10	25V	X7R	0805	AVX	08053C105KAT2A
3	2	R4, R5	DNP	1	DNP		0805	GENERIC	
4	2	R1, R2	10Ω	1	1/10W		0805	VENKEL	CR0805-8W-10R0FT
5	5	R6, R7, R8, R9, R10	10KΩ	1	1/10W		0805	VENKEL	CR0805-8W-1002FT(Pb-free)
6	1	R11	49.9Ω	1	1/10W		0805	ROHM	MCR10EZHF49R9
7	3	SP1-SP3					CONN	TEKTRONIX	131-4353-00
8	18	P1-P18					THOLE	KEYSTONE	1514-2
9	1	BNC1					CONN	AMPHENOL	31-5329-51RFX
10	1	SW1					DIP	GRAYHILL	78B06S
11	1	U1					28CDFP	INTERSIL	ISL71840SEH/PROTO
12	16	J1-J16					THOLE	BERG/FCI	68000-236HLF
13	10	J17-J26						BERG/FCI	69190-202HLF
14	4	Bottom four corners						3M	SJ-5003SPBL

## Board Layout - 4 Layers

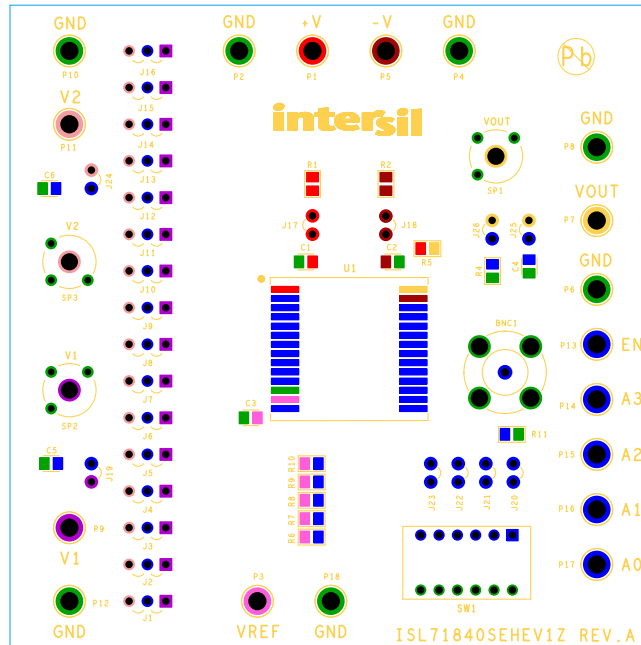

FIGURE 5. SILKSCREEN TOP

## Board Layout - 4 Layers (Continued)

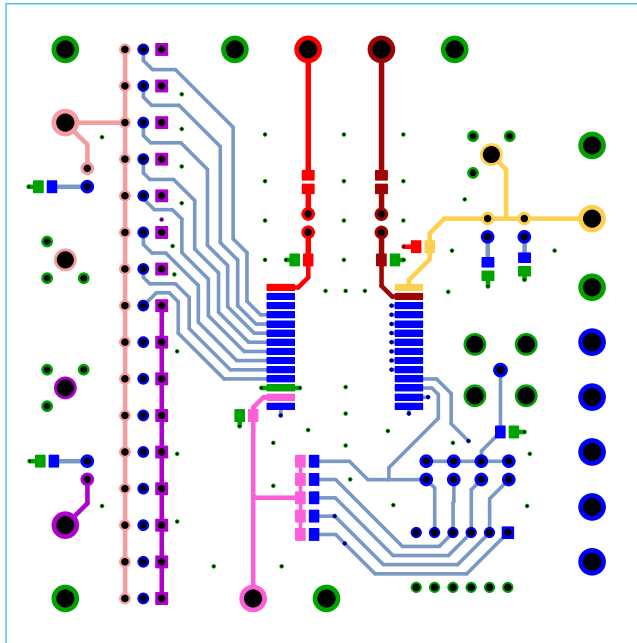

FIGURE 6. TOP LAYER

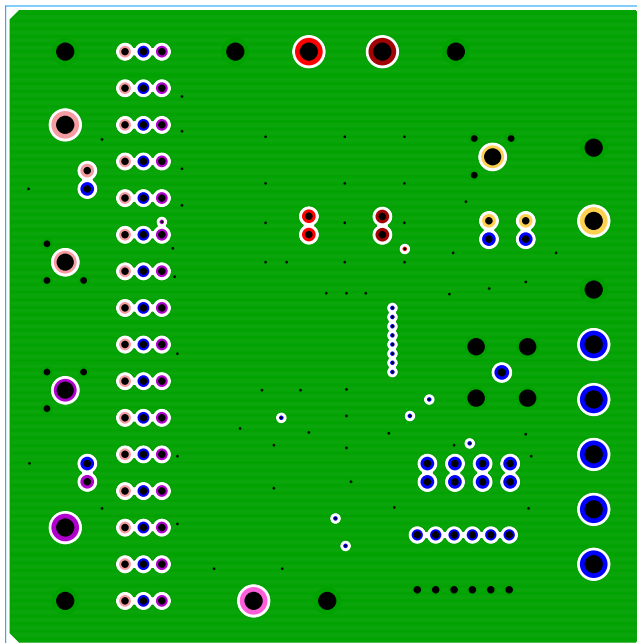

FIGURE 7. PCB - INNER LAYER 1 (TOP VIEW)

## Board Layout - 4 Layers (Continued)

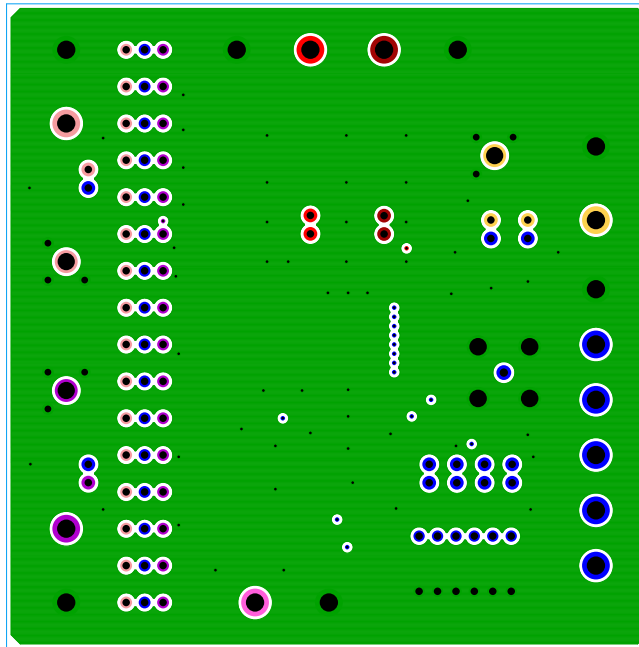

FIGURE 8. PCB - INNER LAYER 2 (TOP VIEW)

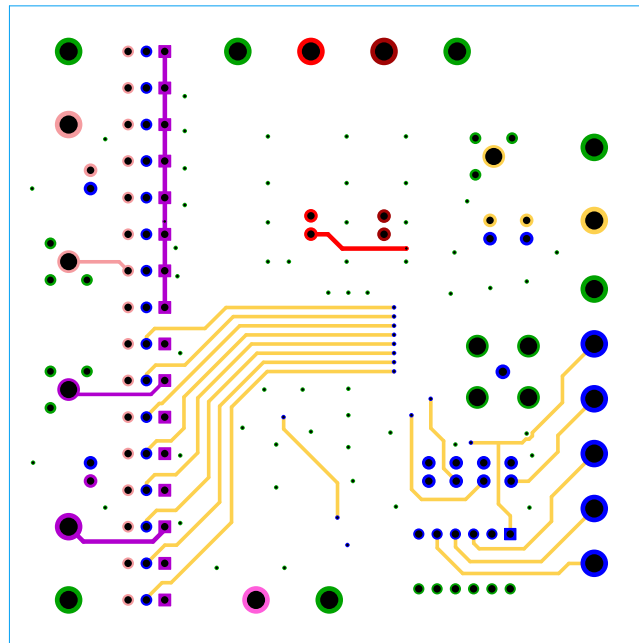

FIGURE 9. PCB - BOTTOM LAYER (TOP VIEW)

## Board Layout - 4 Layers (Continued)

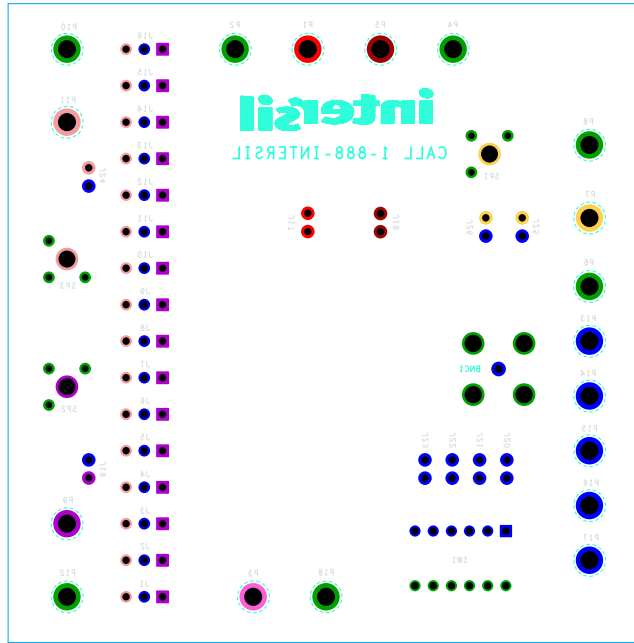

FIGURE 10. SILKSCREEN BOTTOM

## Typical Performance Curves

Unless otherwise noted:  $V_+ = +15V$ ,  $V_- = -15V$ ,  $V_{REF} = 5.0V$ ,  $T_A = +25^\circ C$

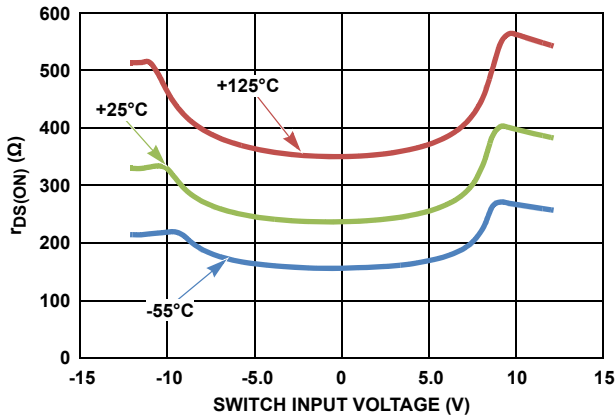

FIGURE 11.  $r_{DS(ON)}$  vs SWITCH INPUT VOLTAGE ( $V_{\pm} = \pm 12.0V$ )

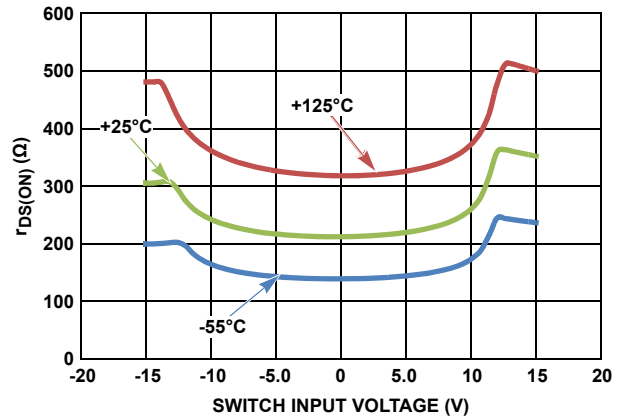

FIGURE 12.  $r_{DS(ON)}$  vs SWITCH INPUT VOLTAGE ( $V_{\pm} = \pm 15.0V$ )

# Typical Performance Curves

Unless otherwise noted:  $V_+ = +15V$ ,  $V_- = -15V$ ,  $V_{REF} = 5.0V$ ,  $T_A = +25^\circ C$  (Continued)

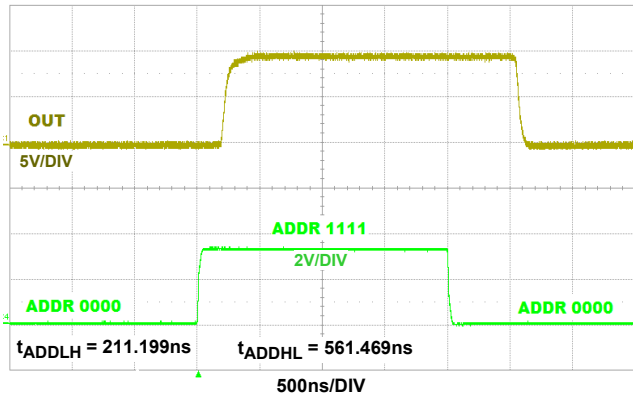

FIGURE 13. TYPICAL ADDRESS TO OUTPUT DELAY ( $V_{\pm} = \pm 15V$ ,  $+25^\circ C$ )

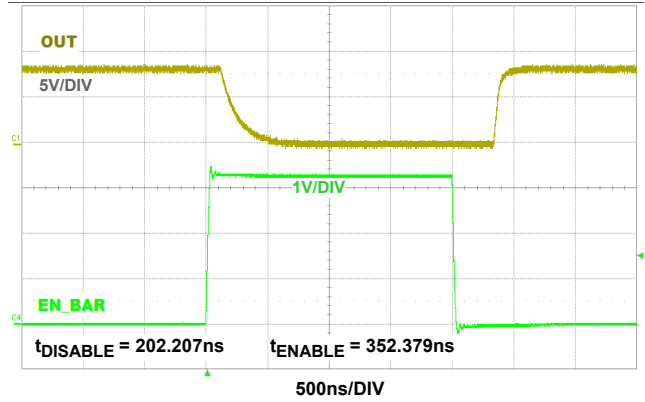

FIGURE 14. TYPICAL ENABLE TO OUTPUT DELAY ( $V_{\pm} = \pm 15V$ ,  $+25^\circ C$ )

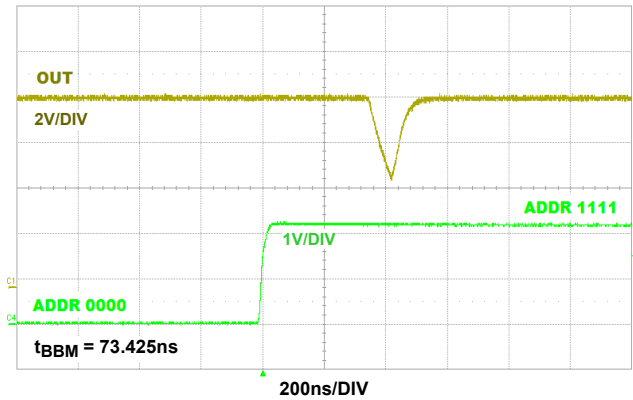

FIGURE 15. TYPICAL BREAK BEFORE MAKE DELAY ( $V_{\pm} = 15V$ ,  $+25^\circ C$ )

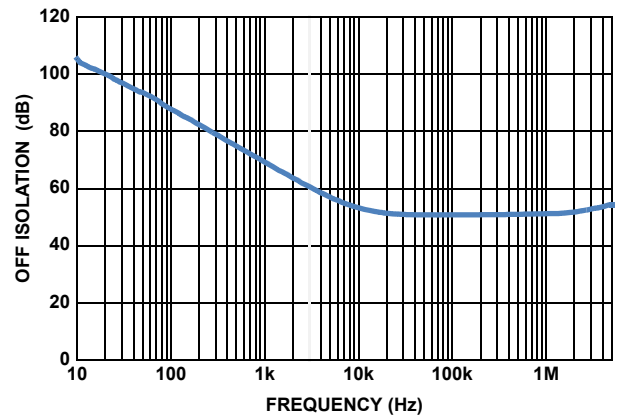

FIGURE 16. OFF ISOLATION ( $V_{\pm} = \pm 15V$ ,  $+25^\circ C$ )

## Notice

1. Descriptions of circuits, software and other related information in this document are provided only to illustrate the operation of semiconductor products and application examples. You are fully responsible for the incorporation or any other use of the circuits, software, and information in the design of your product or system. Renesas Electronics disclaims any and all liability for any losses and damages incurred by you or third parties arising from the use of these circuits, software, or information.
2. Renesas Electronics hereby expressly disclaims any warranties against and liability for infringement or any other claims involving patents, copyrights, or other intellectual property rights of third parties, by or arising from the use of Renesas Electronics products or technical information described in this document, including but not limited to, the product data, drawings, charts, programs, algorithms, and application examples.
3. No license, express, implied or otherwise, is granted hereby under any patents, copyrights or other intellectual property rights of Renesas Electronics or others.
4. You shall not alter, modify, copy, or reverse engineer any Renesas Electronics product, whether in whole or in part. Renesas Electronics disclaims any and all liability for any losses or damages incurred by you or third parties arising from such alteration, modification, copying or reverse engineering.
5. Renesas Electronics products are classified according to the following two quality grades: "Standard" and "High Quality". The intended applications for each Renesas Electronics product depends on the product's quality grade, as indicated below.  
"Standard": Computers; office equipment; communications equipment; test and measurement equipment; audio and visual equipment; home electronic appliances; machine tools; personal electronic equipment; industrial robots; etc.  
"High Quality": Transportation equipment (automobiles, trains, ships, etc.); traffic control (traffic lights); large-scale communication equipment; key financial terminal systems; safety control equipment; etc.  
Unless expressly designated as a high reliability product or a product for harsh environments in a Renesas Electronics data sheet or other Renesas Electronics document, Renesas Electronics products are not intended or authorized for use in products or systems that may pose a direct threat to human life or bodily injury (artificial life support devices or systems; surgical implantations; etc.), or may cause serious property damage (space system; undersea repeaters; nuclear power control systems; aircraft control systems; key plant systems; military equipment; etc.). Renesas Electronics disclaims any and all liability for any damages or losses incurred by you or any third parties arising from the use of any Renesas Electronics product that is inconsistent with any Renesas Electronics data sheet, user's manual or other Renesas Electronics document.
6. When using Renesas Electronics products, refer to the latest product information (data sheets, user's manuals, application notes, "General Notes for Handling and Using Semiconductor Devices" in the reliability handbook, etc.), and ensure that usage conditions are within the ranges specified by Renesas Electronics with respect to maximum ratings, operating power supply voltage range, heat dissipation characteristics, installation, etc. Renesas Electronics disclaims any and all liability for any malfunctions, failure or accident arising out of the use of Renesas Electronics products outside of such specified ranges.
7. Although Renesas Electronics endeavors to improve the quality and reliability of Renesas Electronics products, semiconductor products have specific characteristics, such as the occurrence of failure at a certain rate and malfunctions under certain use conditions. Unless designated as a high reliability product or a product for harsh environments in a Renesas Electronics data sheet or other Renesas Electronics document, Renesas Electronics products are not subject to radiation resistance design. You are responsible for implementing safety measures to guard against the possibility of bodily injury, injury or damage caused by fire, and/or danger to the public in the event of a failure or malfunction of Renesas Electronics products, such as safety design for hardware and software, including but not limited to redundancy, fire control and malfunction prevention, appropriate treatment for aging degradation or any other appropriate measures. Because the evaluation of microcomputer software alone is very difficult and impractical, you are responsible for evaluating the safety of the final products or systems manufactured by you.
8. Please contact a Renesas Electronics sales office for details as to environmental matters such as the environmental compatibility of each Renesas Electronics product. You are responsible for carefully and sufficiently investigating applicable laws and regulations that regulate the inclusion or use of controlled substances, including without limitation, the EU RoHS Directive, and using Renesas Electronics products in compliance with all these applicable laws and regulations. Renesas Electronics disclaims any and all liability for damages or losses occurring as a result of your noncompliance with applicable laws and regulations.
9. Renesas Electronics products and technologies shall not be used for or incorporated into any products or systems whose manufacture, use, or sale is prohibited under any applicable domestic or foreign laws or regulations. You shall comply with any applicable export control laws and regulations promulgated and administered by the governments of any countries asserting jurisdiction over the parties or transactions.
10. It is the responsibility of the buyer or distributor of Renesas Electronics products, or any other party who distributes, disposes of, or otherwise sells or transfers the product to a third party, to notify such third party in advance of the contents and conditions set forth in this document.
11. This document shall not be reprinted, reproduced or duplicated in any form, in whole or in part, without prior written consent of Renesas Electronics.
12. Please contact a Renesas Electronics sales office if you have any questions regarding the information contained in this document or Renesas Electronics products.  
(Note 1) "Renesas Electronics" as used in this document means Renesas Electronics Corporation and also includes its directly or indirectly controlled subsidiaries.  
(Note 2) "Renesas Electronics product(s)" means any product developed or manufactured by or for Renesas Electronics.

(Rev.4.0-1 November 2017)



### SALES OFFICES

Renesas Electronics Corporation

<http://www.renesas.com>

Refer to "<http://www.renesas.com/>" for the latest and detailed information.

**Renesas Electronics America Inc.**  
1001 Murphy Ranch Road, Milpitas, CA 95035, U.S.A.  
Tel: +1-408-432-8888, Fax: +1-408-434-5351

**Renesas Electronics Canada Limited**  
9251 Yonge Street, Suite 8309 Richmond Hill, Ontario Canada L4C 9T3  
Tel: +1-905-237-2004

**Renesas Electronics Europe Limited**  
Dukes Meadow, Millboard Road, Bourne End, Buckinghamshire, SL8 5FH, U.K  
Tel: +44-1628-651-700, Fax: +44-1628-651-804

**Renesas Electronics Europe GmbH**  
Arcadiastrasse 10, 40472 Düsseldorf, Germany  
Tel: +49-211-6503-0, Fax: +49-211-6503-1327

**Renesas Electronics (China) Co., Ltd.**  
Room 1709 Quantum Plaza, No.27 ZhichunLu, Haidian District, Beijing, 100191 P. R. China  
Tel: +86-10-8235-1155, Fax: +86-10-8235-7679

**Renesas Electronics (Shanghai) Co., Ltd.**  
Unit 301, Tower A, Central Towers, 555 Langao Road, Putuo District, Shanghai, 200333 P. R. China  
Tel: +86-21-2226-0888, Fax: +86-21-2226-0999

**Renesas Electronics Hong Kong Limited**  
Unit 1601-1611, 16/F., Tower 2, Grand Century Place, 193 Prince Edward Road West, Mongkok, Kowloon, Hong Kong  
Tel: +852-2265-6688, Fax: +852-2886-9022

**Renesas Electronics Taiwan Co., Ltd.**  
13F, No. 363, Fu Shing North Road, Taipei 10543, Taiwan  
Tel: +886-2-8175-9600, Fax: +886-2-8175-9670

**Renesas Electronics Singapore Pte. Ltd.**  
80 Bendemeer Road, Unit #06-02 Hyflux Innovation Centre, Singapore 339949  
Tel: +65-6213-0200, Fax: +65-6213-0300

**Renesas Electronics Malaysia Sdn.Bhd.**  
Unit 1207, Block B, Menara Amcorp, Amcorp Trade Centre, No. 18, Jln Persiaran Barat, 46050 Petaling Jaya, Selangor Darul Ehsan, Malaysia  
Tel: +60-3-7955-9390, Fax: +60-3-7955-9510

**Renesas Electronics India Pvt. Ltd.**  
No.777C, 100 Feet Road, HAL 2nd Stage, Indiranagar, Bangalore 560 038, India  
Tel: +91-80-67208700, Fax: +91-80-67208777

**Renesas Electronics Korea Co., Ltd.**  
17F, KAMCO Yangjae Tower, 262, Gangnam-daero, Gangnam-gu, Seoul, 06265 Korea  
Tel: +82-2-558-3737, Fax: +82-2-558-5338