

ISL71218MEVAL1Z

User's Manual: Evaluation Board

High Reliability Space

ISL71218MEVAL1Z

Evaluation Board

UG139
Rev.0.00
Aug 17, 2017

1. Overview

The ISL71218MEVAL1Z evaluation platform is designed to evaluate the [ISL71218M](#). The ISL71218 is a single supply, rail-to-rail output, dual amplifier with ground sensing inputs that allow the common-mode input voltage to swing 0.5V below the V- rail. The ISL71218 can operate from a single or dual supply with a 3V to 40V supply range. The ISL71218 features very low power, low offset voltage, and low temperature drift, making it ideal for applications for precision instrumentation, current sensing, and power supply and industrial process controls.

1.1 Key Features

- Wide V_{IN} range single or dual supply operation
 - +1.8V/-1.2V to $\pm 20V$
 - 3.0V to 40V
- Singled-ended or differential input operation
- External VREF input
- Banana jack connectors for power supply and VREF inputs
- BNC connectors for op amp input and output terminals
- Convenient PCB pads for op amp input/output impedance loading

1.2 Specifications

- V+ range: 1.8V to 20V
- V- range: -1.2V to -20V

1.3 Ordering Information

Part Number	Description
ISL71218MEVAL1Z	ISL71218MEVAL1Z evaluation board

1.4 Related Literature

- For a full list of related documents, visit our website
 - [ISL71218M](#) product page

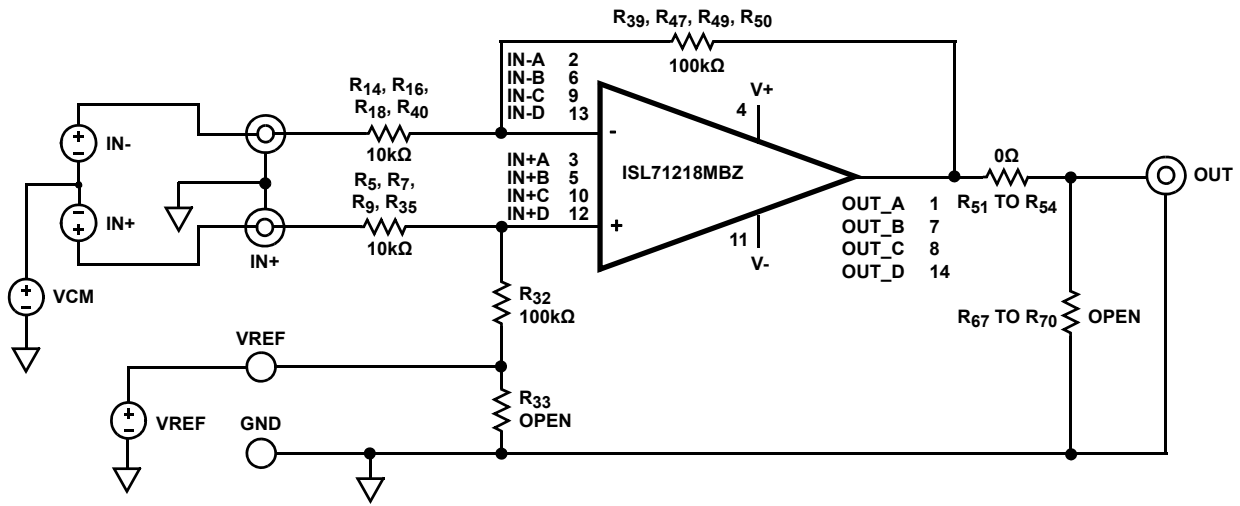

Figure 1. Basic Differential Amplifier Configuration

2. Functional Description

2.1 Power Supply Connections

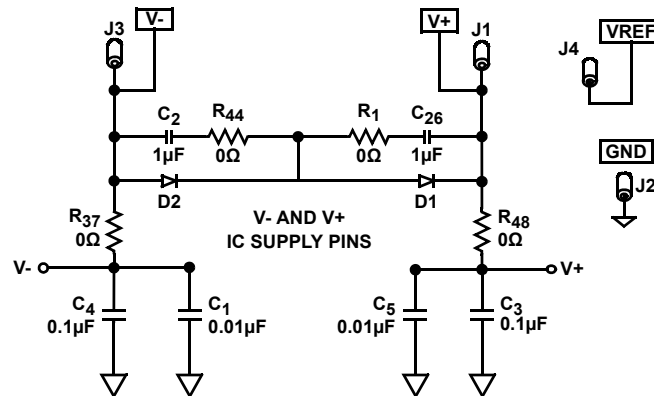

Figure 2. Power Supply Circuit

Figure 2 shows the power supply connections, decoupling and protection circuitry. External power connections are made through the V+, V-, VREF, and GND banana jack connections on the evaluation board. Decoupling capacitors, C₂ and C₂₆, provide low-frequency power-supply filtering, while additional capacitors (C₁, C₃, C₄, and C₅, connected close to the part) filter out high-frequency noise, and are connected to their respective supplies through R₃₇ and R₄₈ resistors. These resistors are 0Ω but can be changed by the user to provide additional power supply filtering, or to reduce the supply voltage rate-of-rise time. Anti-reverse diodes, D1 and D2, protect the circuit in case of momentarily reversing the power supplies accidentally to the evaluation board. The VREF pin can be connected to ground to establish a ground referenced input for split supply operation.

2.2 Amplifier Configuration

A simplified schematic of the evaluation board is shown in Figure 1 on page 3. The input stage with the components supplied is shown in Figure 3. The circuit implements a Hi-Z differential input with unbalanced common-mode impedance. The differential amplifier gain is expressed in Equation 1:

$$(EQ. 1) \quad V_{OUT} = (V_{IN+} - V_{IN-}) \cdot (R_F/R_{IN}) + V_{REF}$$

For a single-ended input with an inverting gain $G = -10V/V$, the IN+ input is grounded and the signal is supplied to the IN- input. VREF must be connected to a reference voltage between the V+ and V- supply rails. For a non-inverting operation with $G = 11V/V$, the negative input (IN-) is grounded and the signal is supplied to the positive input (IN+). The non-inverting gain is strongly dependent on any resistance from IN- to GND. For good gain accuracy, a 0Ω resistor should be installed on the empty R₁₁ pad.

2.3 User-Selectable Options

Component pads are included to enable a variety of user-selectable circuits to be added to the amplifier inputs, the VREF input, outputs, and the amplifier feedback loops.

A voltage divider can be added to establish a power supply-tracking common-mode reference using the VREF input. The inverting and noninverting inputs have additional resistor and capacitor placements for adding input attenuation or feedback capacitors ([Figure 3](#)).

The outputs ([Figure 4](#)) also have additional resistor and capacitor placements for filtering and loading.

Note: Operational amplifiers are sensitive to output capacitance and may oscillate. In the event of oscillation, reduce output capacitance by using shorter cables, or add a resistor in series with the output.

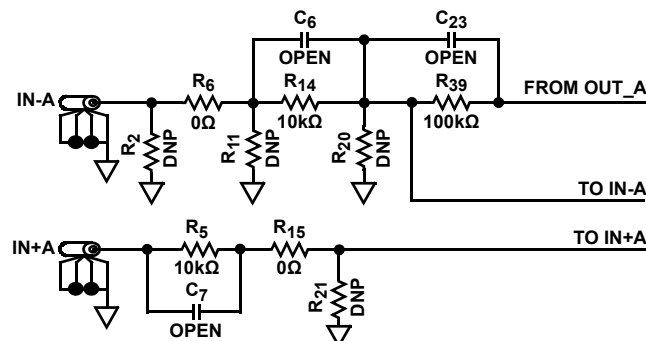

Figure 3. Input Stage

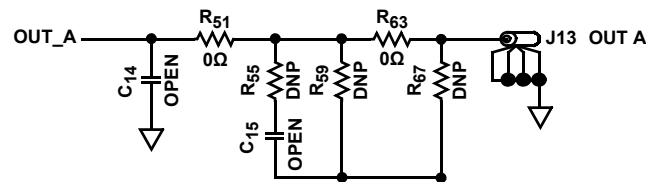

Figure 4. Output Stage

3. PCB Layout Guidelines

Analog circuits can conduct noise through paths that connect it to the “outside world”. To minimize the effects of any noise through the power lines, it is recommended to decouple the power supply pins (V+ and V-). If the trace lines to the power supply pins are long, it is recommended to place high frequency decoupling capacitors (such as 0.1 μ F) right next to the power supply in, and a larger capacitor value (such as 1 μ F) at the point of entry for the power supply.

3.1 ISL71218MEVAL1Z Evaluation Board

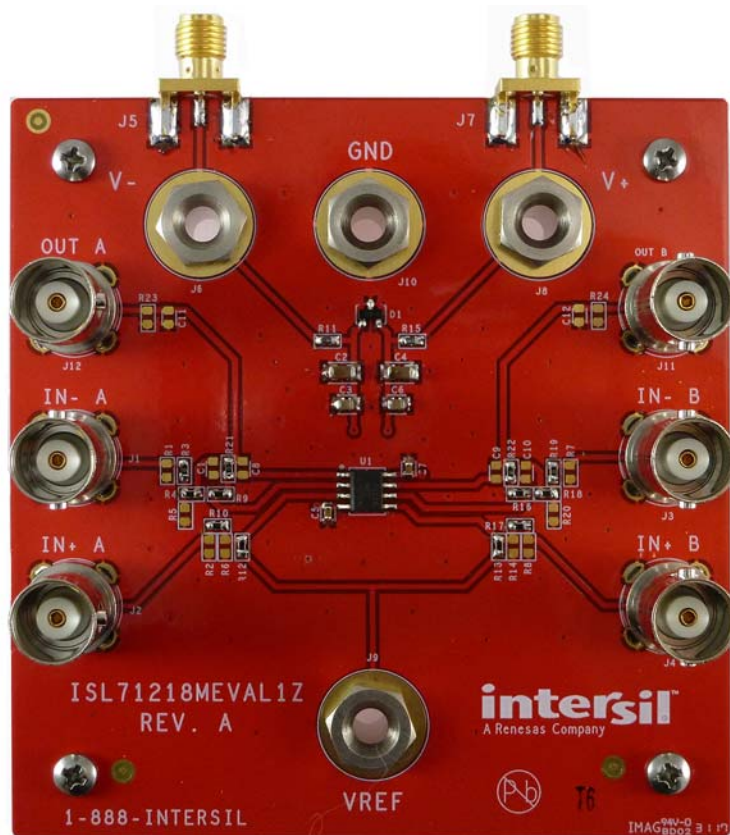

Figure 5. ISL71218MEVAL1Z Evaluation Board

3.2 ISL71218MEVAL1Z Schematic Diagram

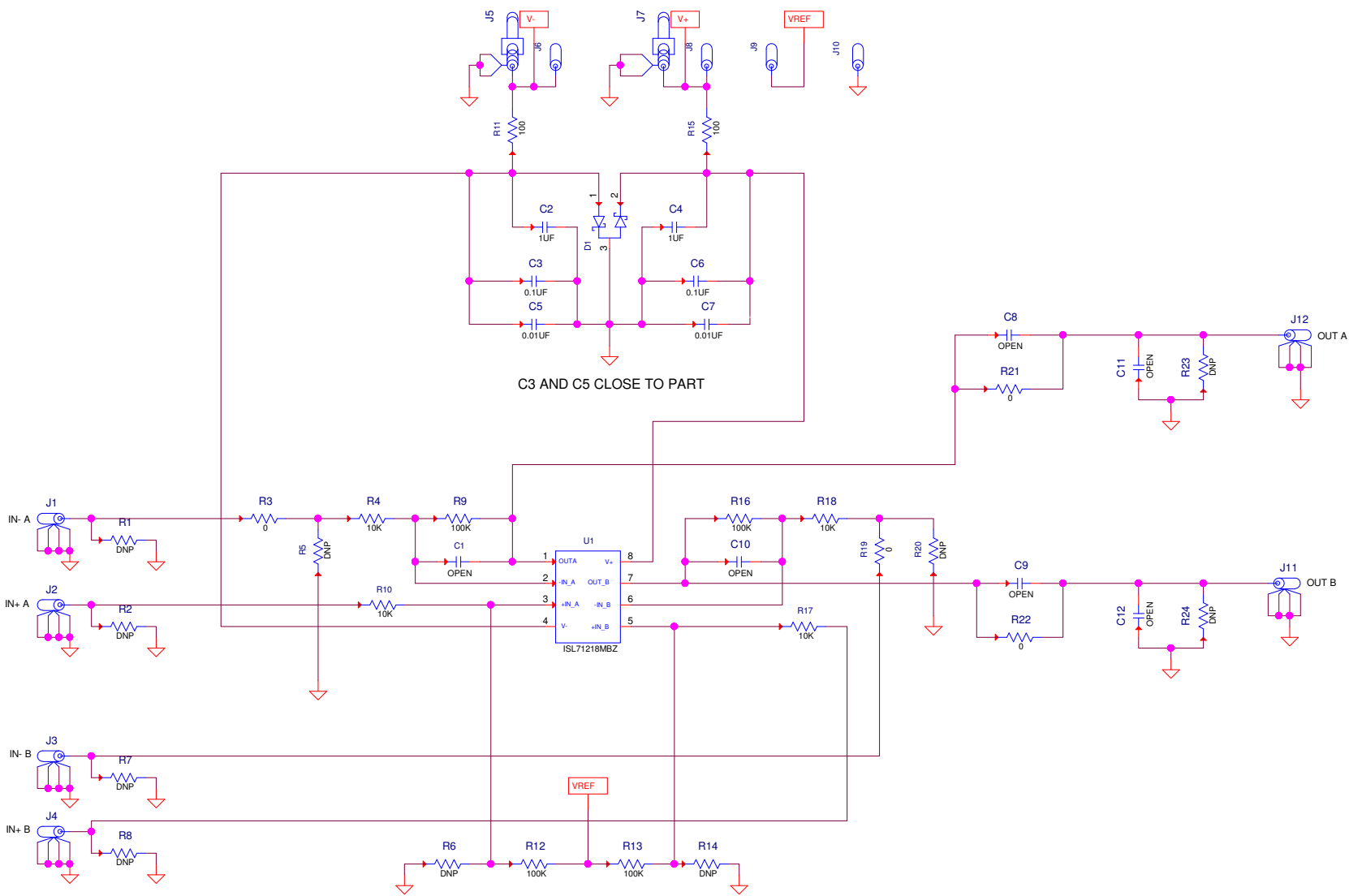

Figure 6. ISL71218MEVAL1Z Schematic

3.3 Bill of Materials

Table 1. ISL71218SRHMEVAL1Z Components Parts List

Device #	Description	Comments
C2, C4	CAP, SMD, 1210, 1μF, 50V, 10%, X7R, ROHS	Power supply decoupling
C3, C6	CAP, SMD, 0805, 0.1μF, 50V, 10%, X7R, ROHS	Power supply decoupling
C5, C7	CAP, SMD, 0603, 0.01μF, 50V, 10%, X7R, ROHS	Power supply decoupling
C1, C8-C12	CAP, SMD, 0603, DNP-PLACE HOLDER, ROHS	User selectable capacitors - not populated
D1	DIODE-RECTIFIER, SMD, SOD-123, 2P, 40V, 0.5A, ROHS	Reverse power protection
U1	ISL71218MBZ, DUAL OP-AMP, 8Ld. SOIC	
R1, R2, R5-R8, R14, R20, R23, R24,	RESISTOR, SMD, 0603, 0.1%, MF, DNP-PLACE HOLDER	User selectable resistors - not populated
R3, R20-R22	RES, SMD, 0603, 0Ω, 1/10W,TF, ROHS	Zero ohm user selectable resistors
R4, R10, R17, R18	RES, SMD, 0603, 10k, 1/10W, 1%, TF, ROHS	Gain resistors
R10, R12, R13, R16	RES, SMD, 0603, 100k, 1/10W, 1%, TF, ROHS	Gain resistors

3.4 Board Layout

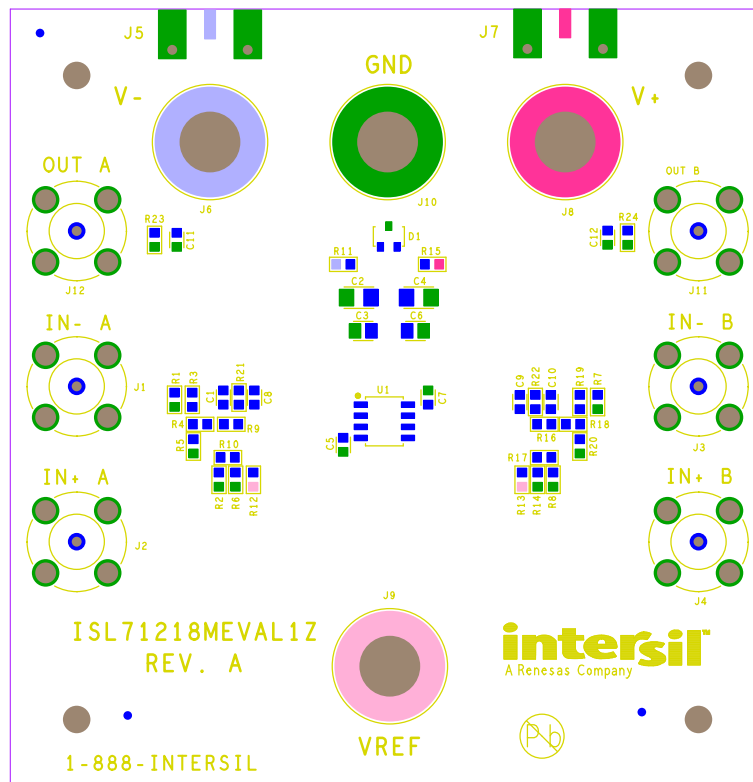

Figure 7. Silkscreen

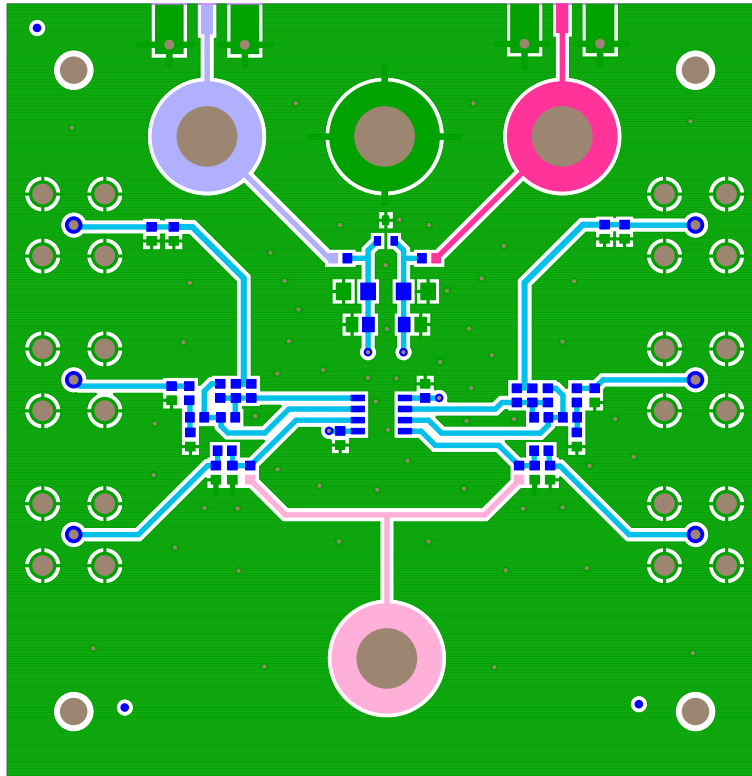

Figure 8. Top Layer

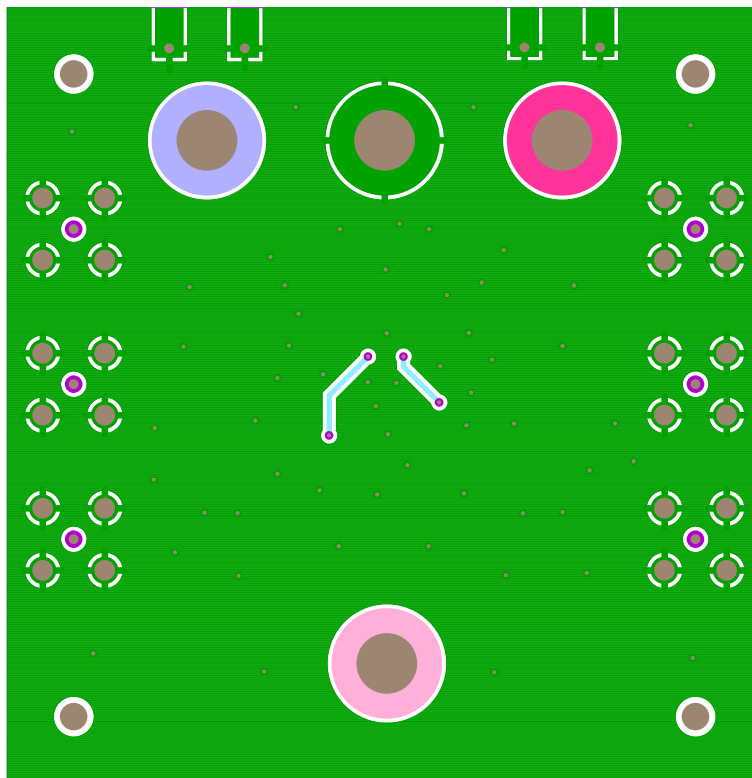

Figure 9. Bottom Layer

4. Typical Performance Curves

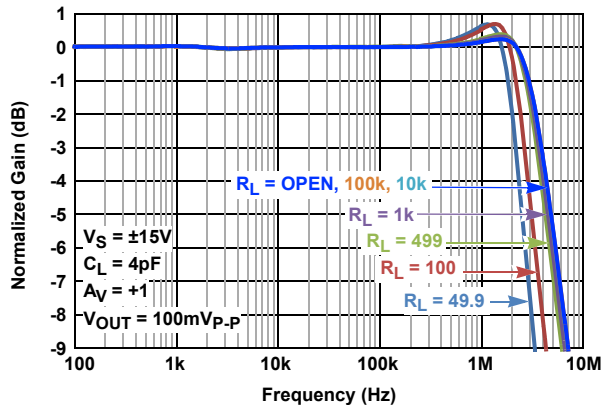

Figure 10. Gain vs Frequency vs R_L , $V_S = \pm 15V$

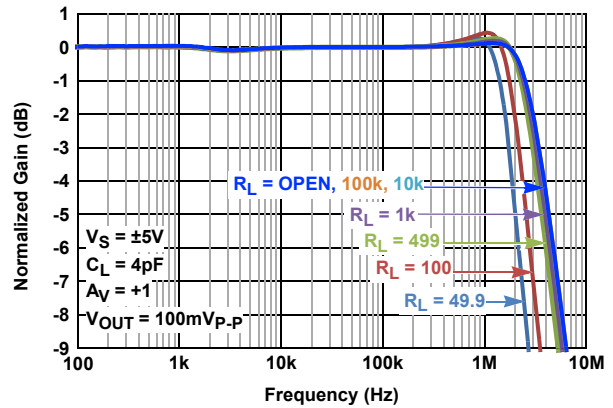

Figure 11. Gain vs Frequency vs R_L , $V_S = \pm 5V$

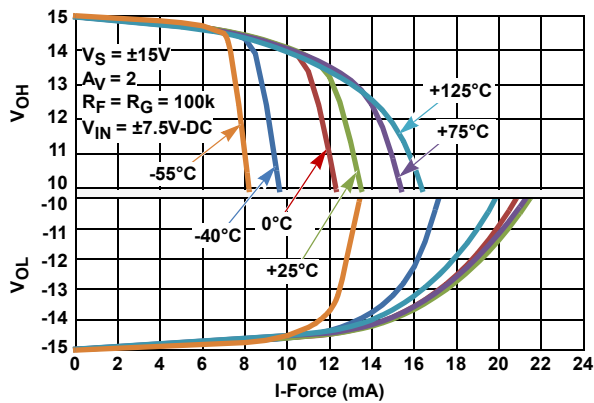

Figure 12. Output Voltage Swing vs Load Current, $V_S = \pm 15V$

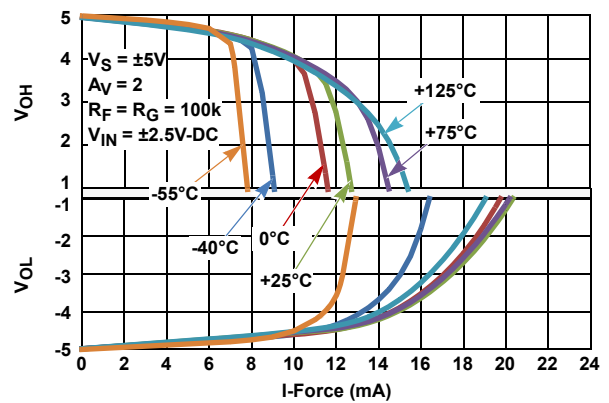

Figure 13. Output Voltage Swing vs Load Current, $V_S = \pm 5V$

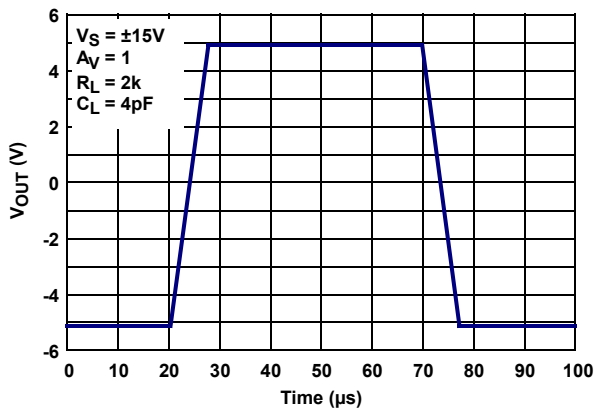

Figure 14. Large Signal 10V Step Response, $V_S = \pm 15V$

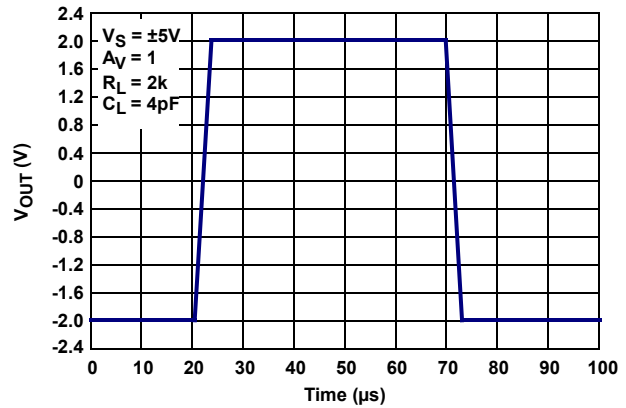

Figure 15. Large Signal 4V Step Response, $V_S = \pm 5V$

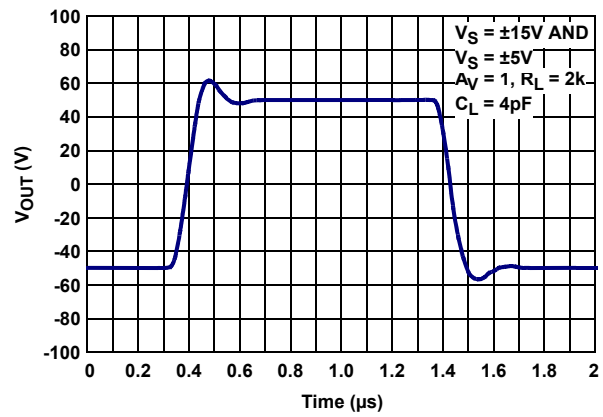

Figure 16. Small Signal Transient Response, $V_S = \pm 5V, \pm 15V$

5. Revision History

Rev.	Date	Description
0.00	Aug 17, 2017	Initial release

© Copyright Intersil Americas LLC 2017. All Rights Reserved.
All trademarks and registered trademarks are the property of their respective owners.

Intersil Corporation reserves the right to make changes in circuit design, software and/or specifications at any time without notice. Accordingly, the reader is cautioned to verify that the document is current before proceeding.

For information regarding Intersil Corporation and its products, see www.intersil.com

ISL71218MEVAL1Z