

### General Description

The SLG59M1526V is designed for load switching application. The part comes with two 4.5A rated MOSFETs switched on by two ON control pins. Each MOSFETs turn on time is independently adjusted by an external capacitor.

### Features

- Two 4.5A independent MOSFETs
- Two Integrated VGS Charge Pumps
- Two internal discharges per channel for gate and source
- Independent Ramp Control
- Protected by thermal shutdown with current limit
- Pb-Free / RoHS Compliant
- Halogen-Free
- STDFN 14L, 2 x 3 x 0.55 mm

### Pin Configuration

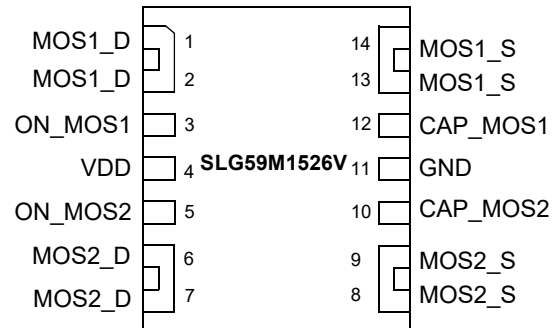

**14-pin STDFN  
(Top View)**

### Applications

- Ideal for switching ON and OFF S0 +5.0 and 3.3 V power rails with associated support circuitry discharges.
- Ideal for switching ON and OFF power rails 5 V or less.
- Can use either channel up to 5.5 A with combined maximum current of 8.5 A
- Maximum load capacitance of 1000  $\mu$ F for each Channel Source terminal.

### Block Diagram

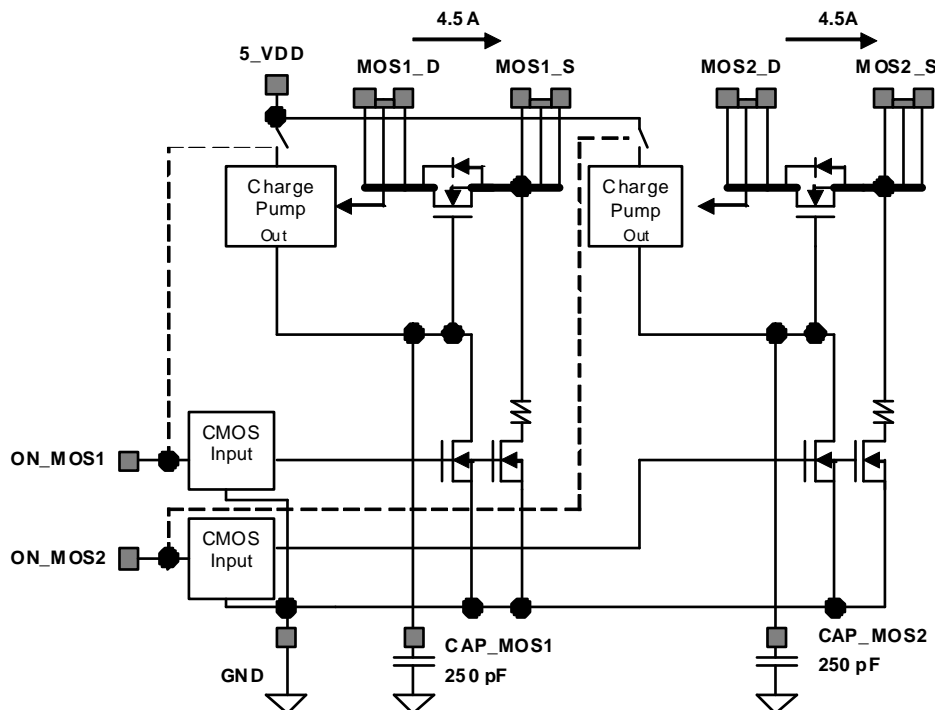

**Do not probe CAP\_MOS1 (PIN 12) or CAP\_MOS2 (PIN 10) with low impedance probe.**

## Pin Description

Pin #	Pin Name	Type	Pin Description
1	MOS1_D	MOSFET	Drain of MOSFET1
2	MOS1_D	MOSFET	Drain of MOSFET1 (fused with pin 1)
3	ON_MOS1	Input	Turns on MOS1 (4 MΩ pull down resistor)
4	VDD	VDD	+5VDD Power
5	ON_MOS2	Input	Turns on MOS2 (4 MΩ pull down resistor)
6	MOS2_D	MOSFET	Drain of MOSFET2
7	MOS2_D	MOSFET	Drain of MOSFET2 (fused with pin 6)
8	MOS2_S	MOSFET	Source of MOSFET2 (fused with pin 9)
9	MOS2_S	MOSFET	Source of MOSFET2
10	CAP_MOS2	Input	Sets ramp and turn on time for MOSFET2
11	GND	GND	Ground
12	CAP_MOS1	Input	Sets ramp and turn on time for MOSFET1
13	MOS1_S	MOSFET	Source of MOSFET1 (fused with pin 14)
14	MOS1_S	MOSFET	Source of MOSFET1

## Ordering Information

Part Number	Type	Production Flow
SLG59M1526V	STDFN 14L	Industrial, -40 °C to 85 °C
SLG59M1526VTR	STDFN 14L (Tape and Reel)	Industrial, -40 °C to 85 °C

## Absolute Maximum Ratings

Parameter	Description	Conditions	Min.	Typ.	Max.	Unit
$V_D$	Power Supply		--	--	6	V
$T_S$	Storage Temperature		-65	--	150	°C
$ESD_{HBM}$	ESD Protection	Human Body Model	2000	--	--	V
$W_{DIS}$	Package Power Dissipation		--	--	1.2	W
$I_{D_{MAX}}$	Max Operating Current				4.5	A
MOSFET $I_{D_{PK}}$	Peak Current from Drain to Source	For no more than 10 continuous seconds out of every 100 seconds	--	--	6	A

Note: Stresses greater than those listed under "Absolute Maximum Ratings" may cause permanent damage to the device. This is a stress rating only and functional operation of the device at these or any other conditions above those indicated in the operational sections of this specification is not implied. Exposure to absolute maximum rating conditions for extended periods may affect reliability.

## Electrical Characteristics

$T_A = -40\text{ °C to }85\text{ °C}$  (unless otherwise stated)

Parameter	Description	Conditions	Min.	Typ.	Max.	Unit
$V_{DD}$	Power Supply Voltage		2.5	--	5.5	V
$I_{DD}$	Power Supply Current when OFF		--	0.1	1	$\mu$ A
	Power Supply Current ON_MOS_1 & ON_MOS_2 (Steady State)		--	50	75	$\mu$ A
$R_{D_{SON}}$	ON Resistance	$T_A$ 25°C MOSFET1 @100 mA	--	14.5	18	m $\Omega$
		$T_A$ 70°C MOSFET1 @100 mA	--	17	22	m $\Omega$
		$T_A$ 85°C MOSFET1 @100 mA		18	23	m $\Omega$
		$T_A$ 25°C MOSFET2 @100 mA	--	14.5	18	m $\Omega$
		$T_A$ 70°C MOSFET2 @100 mA	--	17	22	m $\Omega$
		$T_A$ 85°C MOSFET2 @100 mA		18	23	m $\Omega$
MOSFET $I_{D_S}$	Current from Drain to Source for each MOSFET	Continuous	--	--	4.5	A
$V_D$	Drain Voltage		0.9	--	$V_{DD}$	V
$T_{ON\_Delay}$	ON pin Delay Time	50% ON to Ramp Begin	0	300	500	$\mu$ s
$T_{Total\_ON}$	Total Turn On Time	50% ON to 90% $V_S$	Configurable <sup>1</sup>			ms
		Example: CAP = 4 nF, $V_{DD} = V_D = 5$ V, Source_Cap = 10 $\mu$ F, $R_L = 20\ \Omega$	--	2.0	--	ms
$T_{SLEWRATE}$	Slew Rate	10% $V_S$ to 90% $V_S$	Configurable <sup>1</sup>			V/ms
		Example: CAP = 4 nF, $V_{DD} = V_D = 5$ V, Source_Cap = 10 $\mu$ F, $R_L = 20\ \Omega$	--	3.0	--	V/ms
$CAP_{SOURCE}$	Source Cap	Source to GND	--	--	1000	$\mu$ F
$R_{DIS}$	Discharge Resistance		100	150	300	$\Omega$
ON_ $V_{IH}$	High Input Voltage on ON pin		0.85	--	$V_{DD}$	V
ON_ $V_{IL}$	Low Input Voltage on ON pin		-0.3	0	0.3	V
$I_{LIMIT}$	Active Current Limit	MOSFET will automatically limit current when $V_S > 250$ mV	--	6.0	--	A
	Short Circuit Current Limit	MOSFET will automatically limit current when $V_S < 250$ mV	--	0.5	--	A
$THERM_{ON}$	Thermal shutoff turn-on temperature		--	125	--	°C
$THERM_{OFF}$	Thermal shutoff turn-off temperature		--	100	--	°C

T<sub>A</sub> = -40 °C to 85 °C (unless otherwise stated)

Parameter	Description	Conditions	Min.	Typ.	Max.	Unit
THERM <sub>TIME</sub>	Thermal shutoff time		--	--	1	ms
T <sub>OFF_Delay</sub>	OFF Delay Time	50% ON to V <sub>S</sub> Fall, V <sub>DD</sub> = V <sub>D</sub> = 5 V	--	--	15	μs

Notes:

1. Refer to table for configuration details.

T<sub>SLEW</sub> vs. CAP

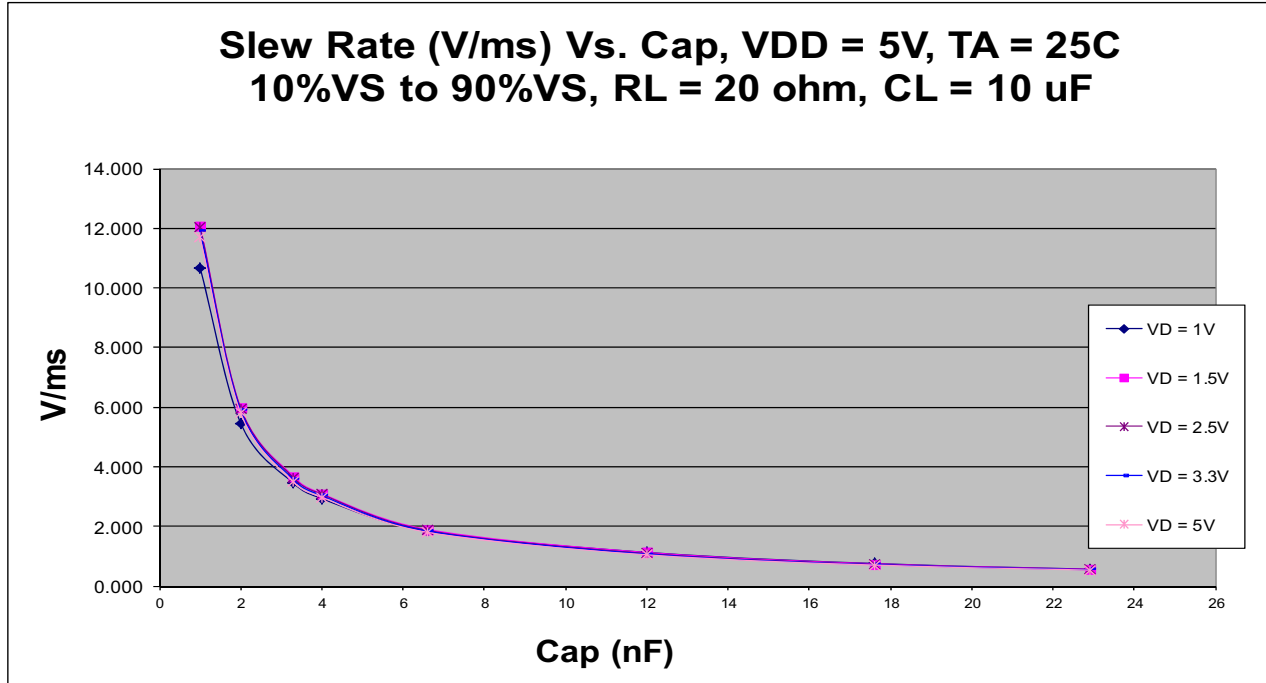

T<sub>TOTAL\_ON</sub> vs. CAP

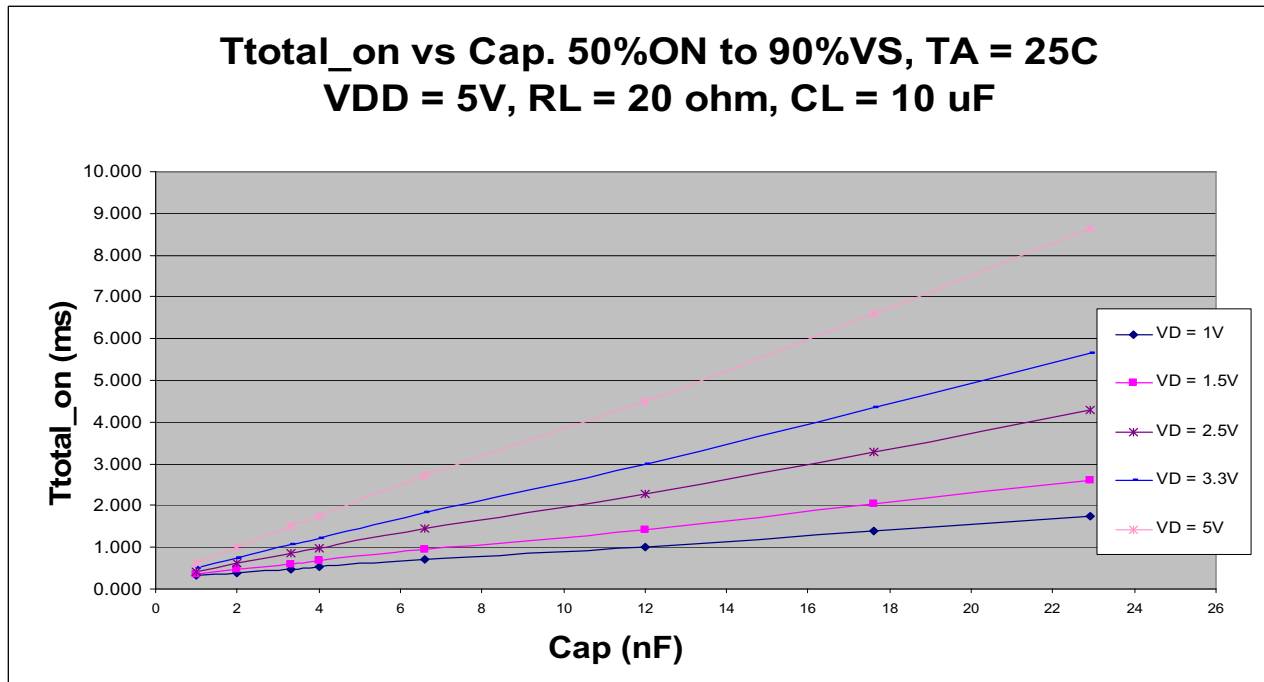

$T_{Total\_ON}$ ,  $T_{ON\_Delay}$  and Slew Rate Measurement

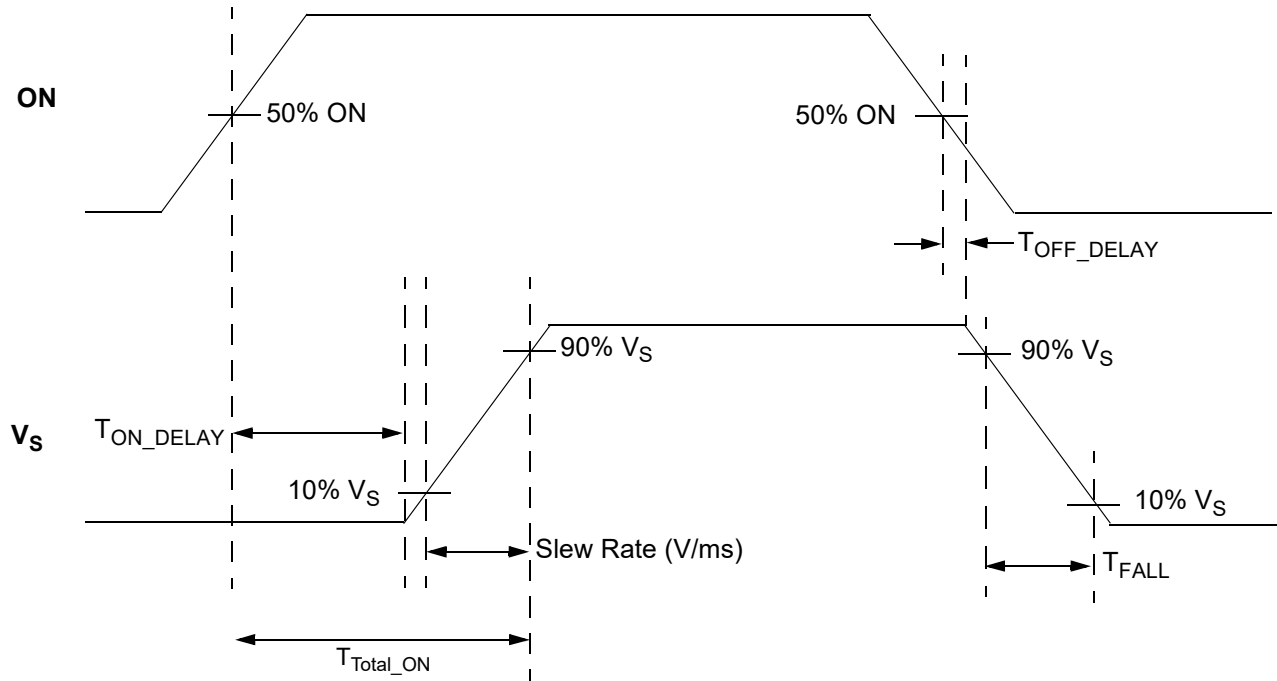

More vias for thermal dissipation is better.

Package Top Marking System Definition

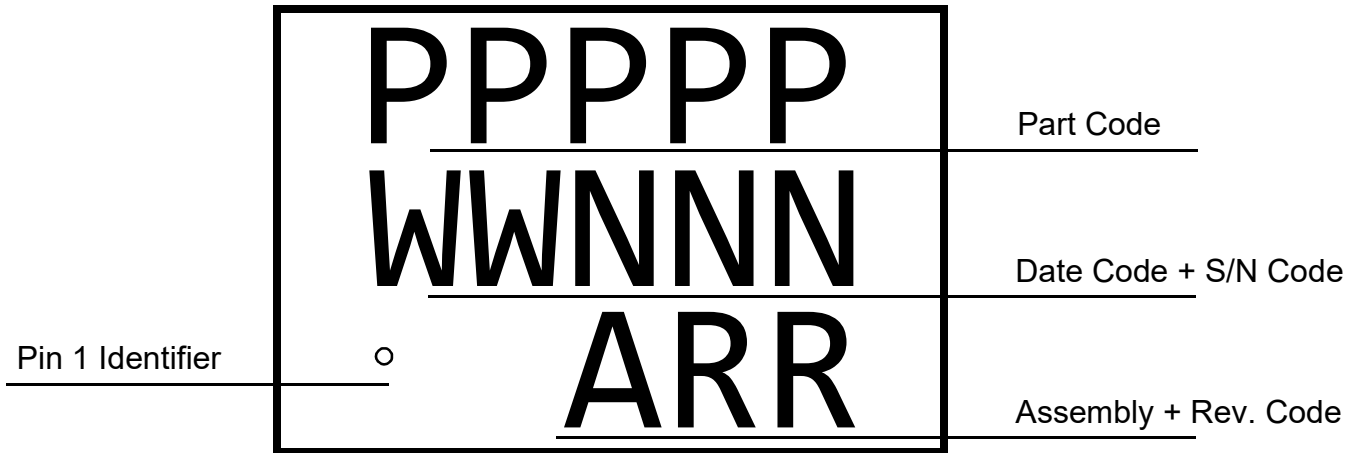

Package Drawing and Dimensions

14 Lead STDFN Package 2 mm x 3 mm (Fused Lead)

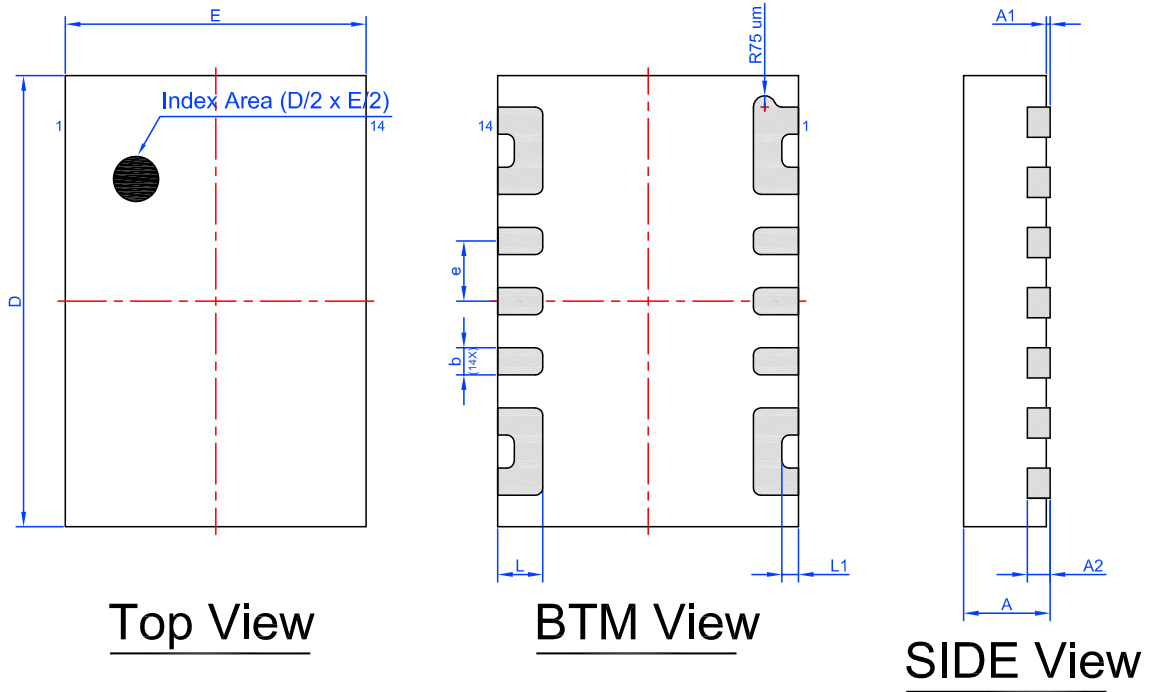

Unit: mm

Symbol	Min	Nom.	Max	Symbol	Min	Nom.	Max
A	0.50	0.55	0.60	D	2.95	3.00	3.05
A1	0.005	-	0.050	E	1.95	2.00	2.05
A2	0.10	0.15	0.20	L	0.25	0.30	0.35
b	0.13	0.18	0.23	L1	0.06	0.11	0.16
e	0.40 BSC						

## Tape and Reel Specifications

Package Type	# of Pins	Nominal Package Size	Units per Reel	Max Units per Box	Reel & Hub Size (mm)	Trailer A		Leader B		Pocket Tape (mm)	
						Pockets	Length (mm)	Pockets	Length (mm)	Width	Pitch
STDFN 14L 2x3 mm 0.4P FC Green	14	2x3x0.55mm	3000	3000	178/60	100	400	100	400	8	4

## Carrier Tape Drawing and Dimensions

Package Type	Pocket BTM Length [mm]	Pocket BTM Width [mm]	Pocket Depth [mm]	Index Hole Pitch [mm]	Pocket Pitch [mm]	Index Hole Diameter [mm]	Index Hole to Tape Edge [mm]	Index Hole to Pocket Center [mm]	Tape Width [mm]
	A0	B0	K0	P0	P1	D0	E	F	W
STDFN 14L 2x3 mm 0.4P FC Green	2.2	3.15	0.76	4	4	1.5	1.75	3.5	8

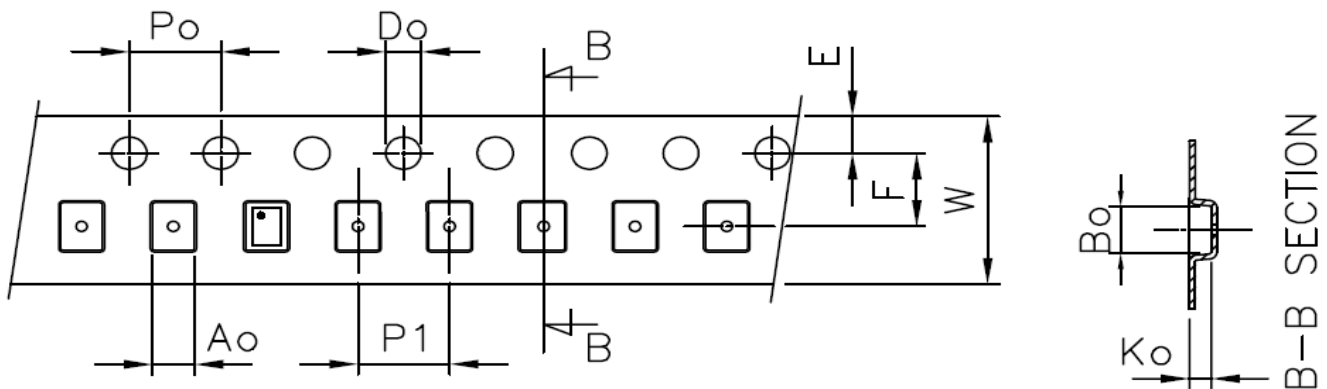

## Recommended Reflow Soldering Profile

Please see IPC/JEDEC J-STD-020: latest revision for reflow profile based on package volume of 3.3 mm<sup>3</sup> (nominal). More information can be found at [www.jedec.org](http://www.jedec.org).

## Revision History

Date	Version	Change
2/4/2022	1.03	Updated Company name and logo Fixed typos
10/8/14	1.02	Updated VD Min from 1.0 V to 0.9 V
7/15/14	1.01	Fixed Part Marking Diagram
4/21/14	1.0	Production Release

## IMPORTANT NOTICE AND DISCLAIMER

RENESAS ELECTRONICS CORPORATION AND ITS SUBSIDIARIES (“RENESAS”) PROVIDES TECHNICAL SPECIFICATIONS AND RELIABILITY DATA (INCLUDING DATASHEETS), DESIGN RESOURCES (INCLUDING REFERENCE DESIGNS), APPLICATION OR OTHER DESIGN ADVICE, WEB TOOLS, SAFETY INFORMATION, AND OTHER RESOURCES “AS IS” AND WITH ALL FAULTS, AND DISCLAIMS ALL WARRANTIES, EXPRESS OR IMPLIED, INCLUDING, WITHOUT LIMITATION, ANY IMPLIED WARRANTIES OF MERCHANTABILITY, FITNESS FOR A PARTICULAR PURPOSE, OR NON-INFRINGEMENT OF THIRD-PARTY INTELLECTUAL PROPERTY RIGHTS.

These resources are intended for developers who are designing with Renesas products. You are solely responsible for (1) selecting the appropriate products for your application, (2) designing, validating, and testing your application, and (3) ensuring your application meets applicable standards, and any other safety, security, or other requirements. These resources are subject to change without notice. Renesas grants you permission to use these resources only to develop an application that uses Renesas products. Other reproduction or use of these resources is strictly prohibited. No license is granted to any other Renesas intellectual property or to any third-party intellectual property. Renesas disclaims responsibility for, and you will fully indemnify Renesas and its representatives against, any claims, damages, costs, losses, or liabilities arising from your use of these resources. Renesas' products are provided only subject to Renesas' Terms and Conditions of Sale or other applicable terms agreed to in writing. No use of any Renesas resources expands or otherwise alters any applicable warranties or warranty disclaimers for these products.

(Disclaimer Rev.1.01)

### Corporate Headquarters

TOYOSU FORESIA, 3-2-24 Toyosu,  
Koto-ku, Tokyo 135-0061, Japan  
[www.renesas.com](http://www.renesas.com)

### Trademarks

Renesas and the Renesas logo are trademarks of Renesas Electronics Corporation. All trademarks and registered trademarks are the property of their respective owners.

### Contact Information

For further information on a product, technology, the most up-to-date version of a document, or your nearest sales office, please visit [www.renesas.com/contact-us/](http://www.renesas.com/contact-us/).