

Features

- Drain Voltage Range 0.7 V to 1.5 V
- Controlled Load Discharge Rate
- Controlled Turn on Slew Rate
- Pb-Free / RoHS compliant
- Halogen-Free
- 2mm x 2mm TDFN-8 Package

Applications

- Low Transient Load Switching
- Personal computers and Servers
- Hot Plugging Applications
- Power Rail Switches

Block Diagram

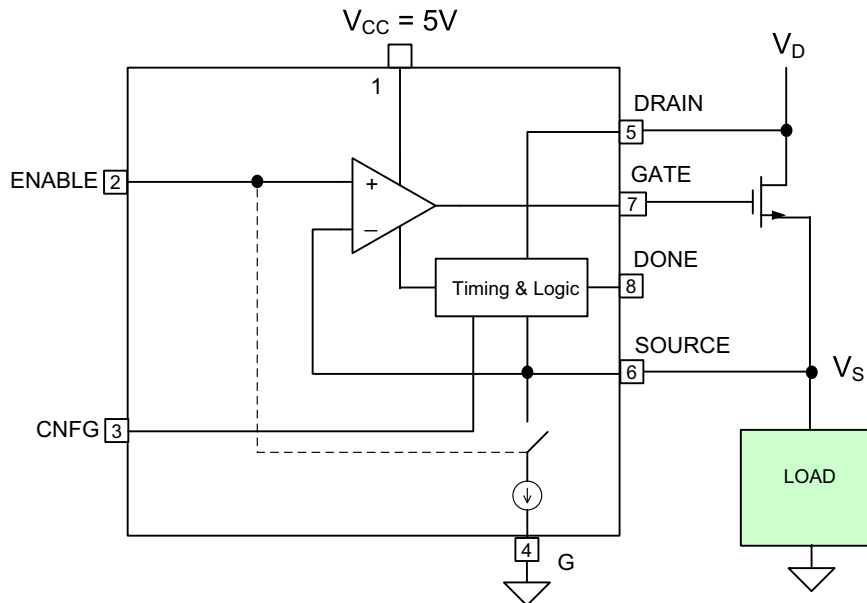

Pin Configuration

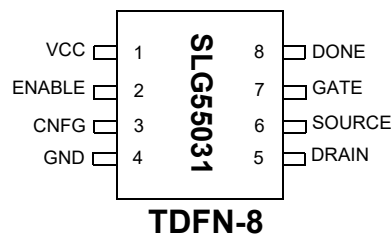

Overview

The SLG55031 N-Channel FET Gate Driver is used for controlling the ramping slew rate of the source voltage on N-Channel FET switches from a CMOS logic level input. Intended as supporting control elements for switched voltage rails in energy efficient advanced power management systems, these devices also include circuits to discharge opened switched voltage rails. SLG55031 uses an external resistor connected between the CNFG pin and GND to establish the slew rate. F

SLG55031 ramps V_S from 10% to 90% of 1.50 V in 33 μ s with External Resistor = 560 k Ω

Pin Description

Pin Name	Pin Number	Type	Pin Description
VCC	1	Power	Supply Voltage 5V
ENABLE	2	Input	CMOS Logic Level. High True for SLG55031
CNFG	3	Input	Resistor or Capacitor Connection for timing configuration
GND	4	GND	Ground.
DRAIN	5	Input	FET Drain Connection
SOURCE	6	Input	Source Connection
GATE	7	Output	FET Gate Drive
DONE	8	Output	Output CMOS Open Drain - Power Good, indicates external FET fully on.

Ordering Information

Part Number	External Timing Component	Enable Polarity	External FET Threshold Voltage Range	Package Type
SLG55031VTR	External Resistor	HIGH True Active	1.5 V < VT < 2.5 V	TDFN-8 - Tape and Reel (3 k units)

Absolute Maximum Conditions

Parameter	Min.	Max.	Unit
V_{CC} to GND	-0.3	6.0	V
Voltage at Logic Input pins	-0.3	6.0	V
Current at input pin	-1.0	1.0	mA
Storage temperature range	-65	150	°C
Operating temperature range	0	70	°C
Junction temperature	--	150	°C
Moisture Sensitivity Level	1		

Electrical Characteristics (-10°C to 75°C)

Symbol	Parameter	Condition/Note	Min.	Typ.	Max.	Unit
V_{CC}	Supply Voltage		4.75	5.0	5.25	V
I_q	Quiescent Current	ENABLE = 1, V_G not ramping		1.5	5	μA
I_{STBY}	Standby Current	ENABLE = 0		2	3	μA
T	Operating Temperature		0	25	70	°C
V_D	Driven FET Drain Voltage	May dynamically vary	0.7	--	1.5	V
V_G	Gate Voltage	Tracks Supply V_{CC}	4.75	5.0	5.25	V
T_{VT}	FET Turn on Delay	FET $V_T < 2.0V$ FET GATE $C_{IN} < 4nF$	3	8	--	μs
$I_{DISCHARGE}$	Internal Discharge Equivalent Current	Discharges MOSFET Source	--	--	10	mA
V_{IH}	HIGH-level input voltage	ENABLE pin	2.0	--	--	V
V_{IL}	LOW-level Input voltage	ENABLE pin	--	--	1.0	V
I_{IH}	HIGH-level Input Current	Digital pins, $V_{IN} = V_{CC}$	-1.0	--	1.0	μA
I_{IL}	LOW-level input Current	Digital pins, $V_{IN} = 0V$	-1.0	--	1.0	μA
V_{OH_LOGIC}	DONE Pull-up Voltage	Open Drain Output Buffer	--	--	5.5	V

Description

In a typical application, de-asserting ENABLE turns off the external power N-FET. The voltage at the load is discharged through the discharge control path internal to the SLG55031. The rate of discharge is current limited to 10 mA.

When ENABLE is asserted, gate voltage is applied to the gate of the external power N-FET within 10 μ s (typical) then the gate voltage is ramped up to $V_{CC} - V_D$ (3.5 V typical) at a slew rate determined by the value of the external resistor or capacitor connected to the CNFG pin of the SLG55031. Monotonic rise of the external FET's source voltage V_S is maintained even as Source current increases after the load device turn on threshold voltage is reached. After the Source voltage has ramped up to the Drain Voltage – the voltage drop contribution by R_{DS-ON} of the FET, the external FET is fully on and the open drain DONE signal is asserted.

If a voltage is not present on the Drain Sense Pin prior to assertion of ENABLE, the FET's gate will be immediately driven high turning the FET fully on.

DONE may be used as the ENABLE control of a second SLG55031 connected in series thereby providing power on sequence control of a number of switched power rails, or used in a 'wired and' with other DONE signals to indicate all switched power rails are in a power good condition.

Configuration Options

The SLG55031 is configured with external passive devices to select between two widely separate ramp slew rates. See the following Table for details

Configuration Pin Usage Table

Resistor to Ground (SLG55031) to 1.5 V Rail			
Value (Ω)	400 K	560 K	750 K
Typical Slew Time (μ s)	23	33	45

Timing Diagram - Initial P-ON

V_{CC} to the SLG55031 must reach V_{CC} min (4.75 V) before the device will begin to be operational. ENABLE¹ must be asserted 100 μ s after 100% of V_{CC} has been attained. If V_{DRAIN} is present at a minimum of 3 μ s prior to assertion of the ENABLE, the Source will begin to ramp towards V_{DRAIN} after T_{VT} (10 μ s typically), the time required for the gate of the FET to be past turn on threshold (typically 2.0 V). Carefully examine specific FET turn-on threshold as well as FET C-IN and if the values fall outside of the range of values covered in the electrical specifications section of this document, consult Renesas for applications assistance in determining the value of T_{VT} .

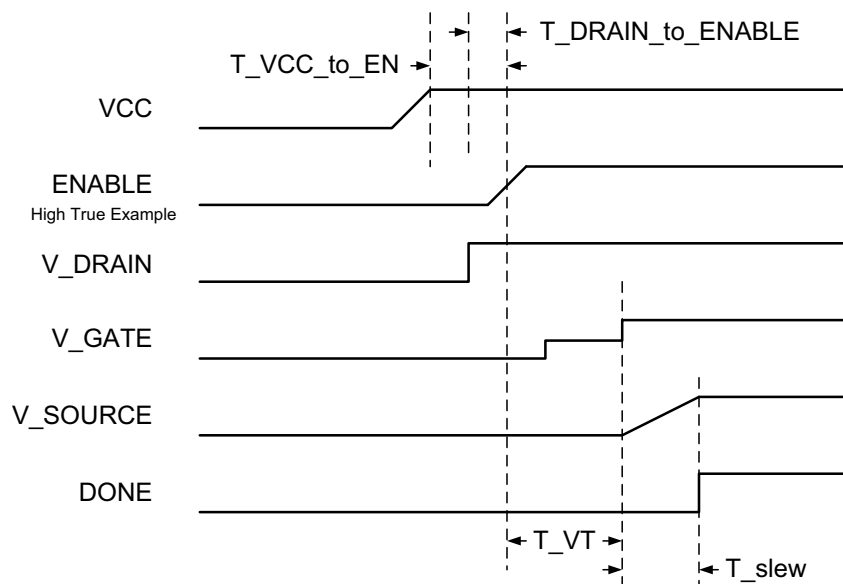

Diagram 1 Enable after VCC

If V_DRAIN is not present prior to the assertion ENABLE, the driven FET will be turned on immediately following assertion of ENABLE and subsequent application of a voltage on the Drain of the FET will be directly applied to the Source (Diagram 2). Again, V_{CC} must have reached V_{CC-MIN} before ENABLE will operate the device. V_{Gate} will be pulled to V_{CC} after which the V_{Source} will track the voltage applied to the Drain of the FET.

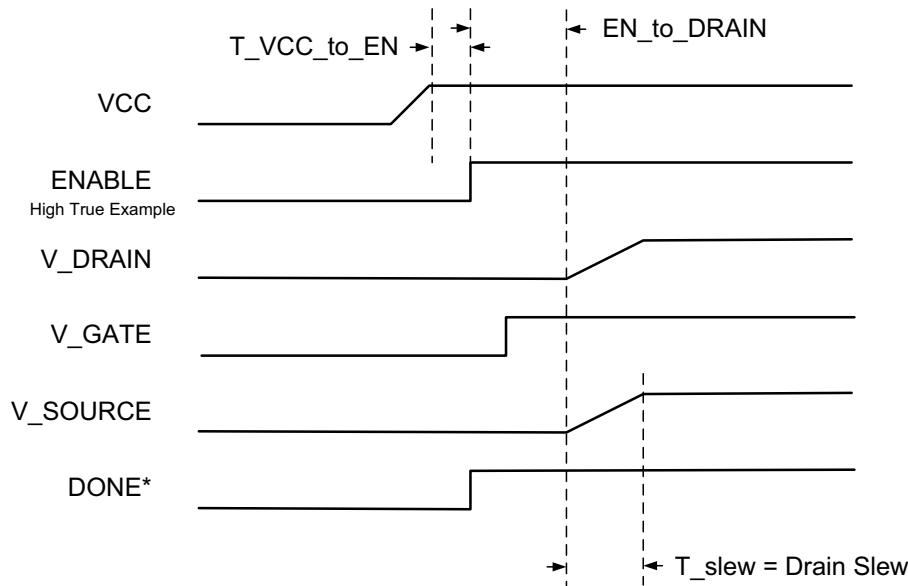

Diagram 2

1 $T_{V_{CC} \text{ to } ENABLE} = 100 \mu s$ assertion delay (when V_{CC} initially ramping up to 100% of V_{CC}).

2 Enable assertion transition time must be less than $1 \mu s$.

* If $V_{Drain} = 0 V$ prior to assertion of ENABLE, DONE becomes true co-incident with assertion of ENABLE.

* In the case of V_{DRAIN} after ENABLE, the definition of Arrival and Ramp Time are not valid

Timing Diagram - Rail Switching

The two components of the FET turn-on time consist of the time it takes to drive the FET's gate up to turn-on threshold (T_{VT}) added to the time it takes for the FET's source voltage to ramp (T_{Slew}) up fully on into the driven load. The timing diagram and table below show the min/max values for these two components vs. different rail source voltage. The T_{VT} delay is $8\ \mu s - 10\ \mu s$ typically (with FET $V_T = 2.0\ V$) depending on the threshold voltage of the FET being driven (Diagram 3).

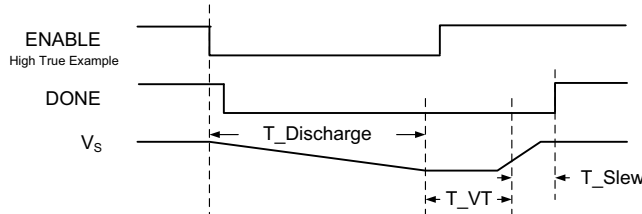

Diagram 3

The Table below and Diagram 3 illustrate source voltage ramp times for various slew rates and resulting total turn on time (ENABLE to DONE) when using the SLG55031 for several selected ranges of drain voltages.

	Min (μSec)	Typ (μSec)	Max (μSec)
SLG55031			
R_ext = 560KΩ	V_Drain Voltage (FET $V_T = 1.5\ V$ to $2.5\ V$)		
		1.35 V	1.50 V
T_{Slew}^*	20	30	33
T_{DONE}^{**}		42	46
Recommended FET: ON Semi NTMFS4834N			

(See Diagram 4 below for more details)

* T_{Slew} : As V_{Source} increases from 10% to 90% of V_{Drain} ; e.g. ramp time

** T_{Done} : From assertion of Enable to $V_{Source} = 90\%$ of V_{Drain} ; e.g. arrival time

Timing Definition of Arrival Time and Ramp Time

Timing for Vcc and Enable

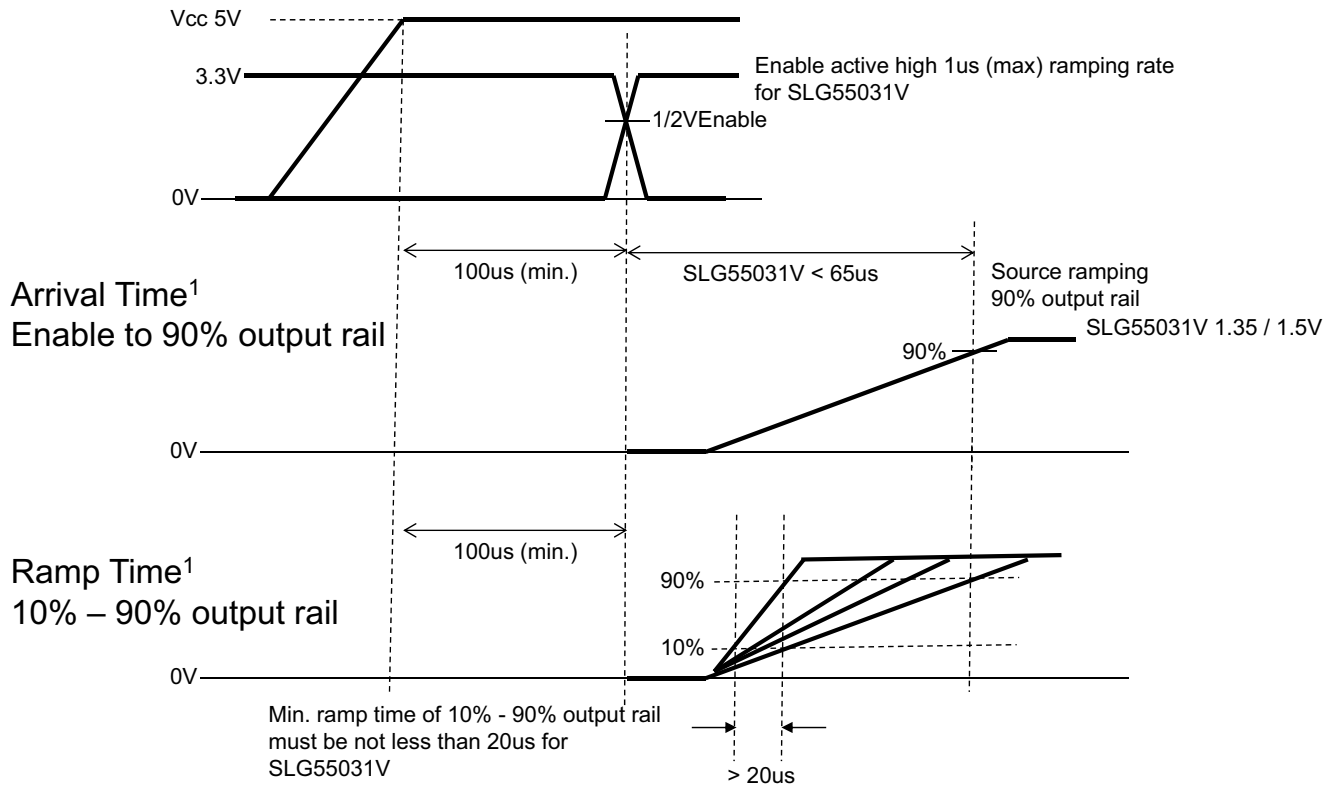

Diagram 4

1 The definition of Arrival Time and Ramp Time is only valid for ENABLE (asserted with a 100 µs delay) after V_{CC} has reached 100% and V_{DRAIN} is present prior to assertion of ENABLE

**Package Top Marking System Definition
For devices manufactured after 2021**

PPP	Part Code
NNN	Serial Number
○ R	Pin 1 Identifier + Revision Code

PPP - Part Code Field: Identifies the specific device Configuration
 NNN - Serial Number Field: Serial number
 R - Revision Code Field: Device Revision

For devices manufactured before 2021

XXA	Part ID + Assembly Code
DDL	Date Code + Lot
○ R	Pin 1 Identifier + Revision Code

XX - Part ID Field: Identifies the specific device Configuration
 A - Assembly Code Field: Assembly Location of the device
 DD - Date Code Field: Coded Date of Manufacture
 L - Lot Code: Designates Lot #
 R - Revision Code: Device Revision

Package Drawing and Dimensions
8 Lead TDFN Package

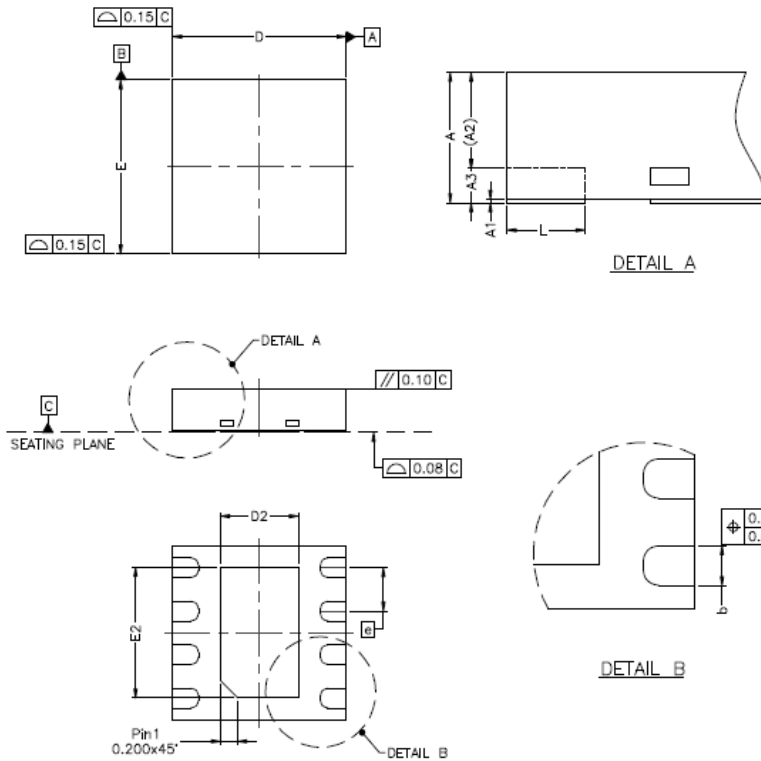

SYMBOL	DIMENSION (MM)			DIMENSION (MIL)		
	MIN.	NOM.	MAX.	MIN.	NOM.	MAX.
A	0.70	0.75	0.80	28	30	31
A1	0.00	0.02	0.05	0	1	2
A2	0	0.55	0.80	0	22	31
A3	—	0.20	—	—	8	—
b	0.18	0.25	0.30	7	10	12
D	1.90	2.00	2.10	74	79	83
D1	—			—		
D2	0.75	0.90	1.05	30	35	41
E	1.90	2.00	2.10	75	79	83
E1	—			—		
E2	1.35	1.50	1.65	53	59	65
e	0.50 BSC			20 BSC		
L	0.25	0.30	0.35	10	12	14

NOTE :

1. REFER TO JEDEC STD: MO-229.
2. DIMENSION "b" APPLIES TO METALLIZED TERMINAL AND IS MEASURED BETWEEN 0.15MM AND 0.30MM FROM THE TERMINAL TIP. IF THE TERMINAL HAS OPTIONAL RADIUS ON THE OTHER END OF THE TERMINAL, THE DIMENSION B SHOULD NOT BE MEASURED IN THAT RADIUS AREA.

Note: Bottom side metal plate is at ground potential

Tape and Reel Specifications

Package Type	# of Pins	Nominal Package Size [mm]	Max Units		Reel & Hub Size [mm]	Leader (min)		Trailer (min)		Tape Width [mm]	Part Pitch [mm]
			per Reel	per Box		Pockets	Length [mm]	Pockets	Length [mm]		
TDFN 8L Green	8	2 x 2 x 0.75	3,000	3,000	178 / 60	100	400	100	400	8	4

Carrier Tape Drawing and Dimensions

Package Type	Pocket BTM Length	Pocket BTM Width	Pocket Depth	Index Hole Pitch	Pocket Pitch	Index Hole Diameter	Index Hole to Tape Edge	Index Hole to Pocket Center	Tape Width
	A0	B0	K0	P0	P1	D0	E	F	W
TDFN 8L Green	2.3	2.3	1.05	4	4	1.55	1.75	3.5	8

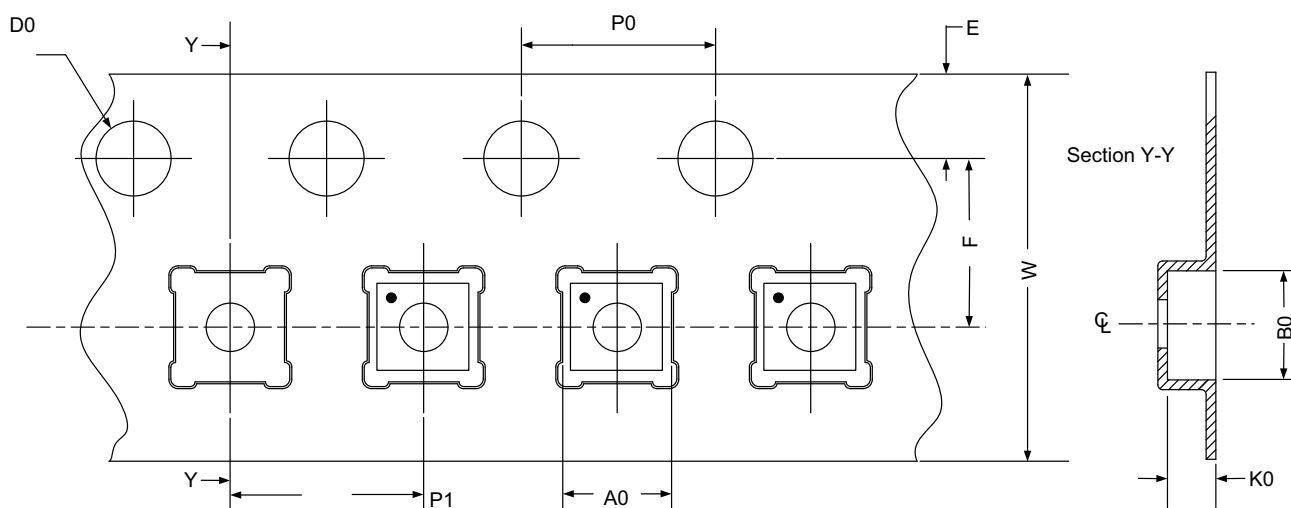

Recommended Reflow Soldering Profile

Please see IPC/JEDEC J-STD-020: latest revision for reflow profile based on package volume of 3.00 mm³ (nominal). More information can be found at www.jedec.org.

Revision History

Date	Version	Change
6/8/2023	1.02	Updated Part Marking Definition
2/9/2022	1.01	Updated Company name and logo Fixed typos

IMPORTANT NOTICE AND DISCLAIMER

RENESAS ELECTRONICS CORPORATION AND ITS SUBSIDIARIES (“RENESAS”) PROVIDES TECHNICAL SPECIFICATIONS AND RELIABILITY DATA (INCLUDING DATASHEETS), DESIGN RESOURCES (INCLUDING REFERENCE DESIGNS), APPLICATION OR OTHER DESIGN ADVICE, WEB TOOLS, SAFETY INFORMATION, AND OTHER RESOURCES “AS IS” AND WITH ALL FAULTS, AND DISCLAIMS ALL WARRANTIES, EXPRESS OR IMPLIED, INCLUDING, WITHOUT LIMITATION, ANY IMPLIED WARRANTIES OF MERCHANTABILITY, FITNESS FOR A PARTICULAR PURPOSE, OR NON-INFRINGEMENT OF THIRD-PARTY INTELLECTUAL PROPERTY RIGHTS.

These resources are intended for developers who are designing with Renesas products. You are solely responsible for (1) selecting the appropriate products for your application, (2) designing, validating, and testing your application, and (3) ensuring your application meets applicable standards, and any other safety, security, or other requirements. These resources are subject to change without notice. Renesas grants you permission to use these resources only to develop an application that uses Renesas products. Other reproduction or use of these resources is strictly prohibited. No license is granted to any other Renesas intellectual property or to any third-party intellectual property. Renesas disclaims responsibility for, and you will fully indemnify Renesas and its representatives against, any claims, damages, costs, losses, or liabilities arising from your use of these resources. Renesas' products are provided only subject to Renesas' Terms and Conditions of Sale or other applicable terms agreed to in writing. No use of any Renesas resources expands or otherwise alters any applicable warranties or warranty disclaimers for these products.

(Disclaimer Rev.1.01)

Corporate Headquarters

TOYOSU FORESIA, 3-2-24 Toyosu,
Koto-ku, Tokyo 135-0061, Japan
www.renesas.com

Trademarks

Renesas and the Renesas logo are trademarks of Renesas Electronics Corporation. All trademarks and registered trademarks are the property of their respective owners.

Contact Information

For further information on a product, technology, the most up-to-date version of a document, or your nearest sales office, please visit www.renesas.com/contact-us/.