

### Features

- $V_{IN}$  range: 4.25 – 21 Volts
- WPC-V1.2.0 MP-A2 medium power specification compatible
- Up to 15W of power transfer
- 80% peak efficiency
- Proprietary slew rate control
  - Very Low EMI
  - Eliminates the need for EMI filter
- Low standby power
- Best in class EMI
- Integrated Step-Down switching regulator
- Simultaneous Voltage and Current demodulation
- Integrated 32bit ARM® Cortex®-M0 Processor
- Supports I<sup>2</sup>C interface
- Over-current and over-temperature protection
- Optional Proprietary bi-directional communication
- -40 to +85°C temperature range
- Available in QFN5mmX5mm, 40 pin package

### Applications

- Charging Mats or Pads
- Tablets
- Phablets
- Portable Instruments

### Description

The P9240A is a new 15W, magnetic induction wireless power transmitter product supporting WPC's MP-A2 coil configurations. The system-on-chip integrates power controller, micro-controller, voltage regulation, foreign object detection (FOD), full bridge power stage drivers and on-chip simultaneous voltage and current demodulation. The product is designed to withstand a wide input voltage range of 4.25 to 21V while consuming 1mA of current during standby mode.

The transmitter includes industry-leading 32bit ARM® Cortex®-M0 processor offering high level of programmability while consuming extremely low standby power meeting the ENERGY STAR® requirement. In addition, the new  $\mu$ Controller empowers the users to customize features such as LED patterns, buzzer and FOD threshold settings. The device supports I<sup>2</sup>C serial interface protocol. The product offers input under-voltage, input overvoltage, output short circuit and over-temperature protection to safeguard the device and system under fault conditions.

The P9240A is available in a Pb-free, space-saving QFN 5mm X 5mm, 40 pin package. The device is rated over an operating temperature range of -40 to +85°C.

### Typical Application

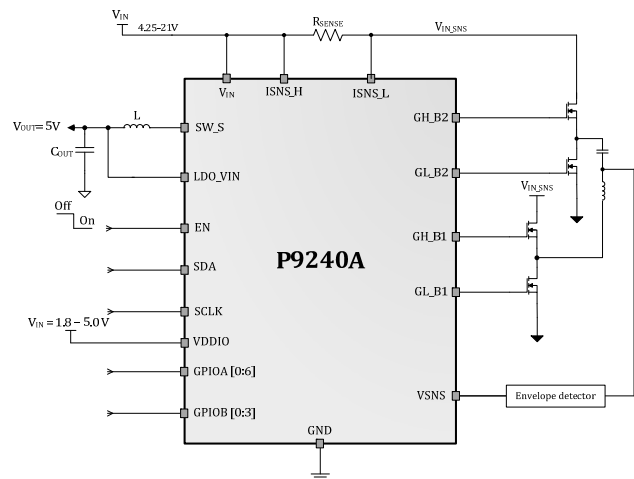

**Package: QFN-40 5mmx5mm (See page 16)**  
**Ordering information (See page 18)**

## ABSOLUTE MAXIMUM RATINGS

These absolute maximum ratings are stress ratings only. Stresses greater than those listed below (Table 1 and Table 2) may cause permanent damage to the device. Functional operation of the P9240A at absolute maximum ratings is not implied. Exposure to absolute maximum rating conditions for extended periods may affect long-term reliability.

**Table 1. Absolute Maximum Ratings Summary. (All voltages are referred to ground.)**

Pins	Rating	Units
ENB, VIN, SW_S, VBRG_IN, SW_BRG1, SW_BRG2, ISNS_H, ISNS_L, BST_BRG1, BST_BRG2, GH_BRG1, GH_BRG2	-0.3 to 28	V
REF_CAP, LDO33_CAP, LDO_VIN, LED1, LED2, VDDIO, GPIOA0, GPIOA1, GPIOA2, GPIOA3, GPIOA4, GPIOA5, GPIOA6, GPIOB0, GPIOB1, GPIOB2, GPIOB3, GL_BRG1, GL_BRG2, VSNS_IN, ISNS_IN, ISNS_OUT, DRV_IN	-0.3 to 6	V
GND	±0.3	V
LDO18_CAP	-0.3 to 2	V

**Table 2<sup>1,2,3</sup>. Package Thermal Information**

SYMBOL	DESCRIPTION	TQFN RATING	UNITS
$\theta_{JA}$	Thermal Resistance Junction to Ambient	28.5	°C/W
$\theta_{JC}$	Thermal Resistance Junction to Case	21.87	°C/W
$\theta_{JB}$	Thermal Resistance Junction to Board	1.27	°C/W
$T_J$	Operating Junction Temperature	-40 to +125	°C
$T_A$	Ambient Operating Temperature	-40 to +85	°C
$T_{STG}$	Storage Temperature	-55 to +150	°C
$T_{LEAD}$	Lead Temperature (soldering, 10s)	+300	°C

**Notes:**

1. The maximum power dissipation is  $P_{D(MAX)} = (T_{J(MAX)} - T_A) / \theta_{JA}$  where  $T_{J(MAX)}$  is 125°C. Exceeding the maximum allowable power dissipation will result in excessive die temperature, and the device will enter thermal shutdown.
2. This thermal rating was calculated on JEDEC 51 standard 4-layer board with dimensions 3" x 4.5" in still air conditions.
3. Actual thermal resistance is affected by PCB size, solder joint quality, layer count, copper thickness, air flow, altitude, and other unlisted variables.

**Table 3. ESD Information**

TEST MODEL	PINS	RATINGS	UNITS
HBM	All pins	+/- 2000	V
CDM	All pins.	+/- 500	V

# SPECIFICATION TABLE

**Table 4. Device Characteristic**

$V_{IN} = 12V$ ,  $V_{DDIO} = 3.3V$ ,  $\overline{EN} = 0V$ , medium power coil configuration,  $T_A = -40$  to  $+85^\circ C$ . Typical values are at  $25^\circ C$ , unless otherwise noted.

Symbol	Description	Conditions/Notes	Min	Typical	Max	Units
<b>Input Supplies and UVLO</b>						
$V_{IN}^1$	Input Operating Range		4.25 <sup>5</sup>	12	21	V
$V_{IN\_UVLO}$	Under-Voltage Lockout	$V_{IN}$ Rising	3.6	4.0	4.2	V
		$V_{IN}$ Falling		3.5		V
$I_{IN}^4$	Operating Mode Input Current	Normal power transfer state		10		mA
$I_{STD\_BY}^4$	Standby Mode Current	Periodic ping		1		mA
$I_{SLP}$	Sleep Mode Input Current			85	150	$\mu A$
$I_{SHD}$	Shutdown Current	$ENB = V_{IN}$		25	80	$\mu A$
<b>Buck Converter<sup>3,4</sup> - <math>C_{OUT} = 20\mu F</math>; <math>L = 4.7\mu H</math></b>						
$V_{OUT}$	Buck Output Voltage	$V_{IN} > 5.5V$	4.85	5.1	5.35	V
$I_{OUT}$	Output Current			50		mA
<b>N-Channel MOSFET Drivers</b>						
$T_{LS\_ON\_OFF}$	Low Side Gate Drive Rise and Fall times	$C_L = 3nF$ ; 10 – 90%, 90 – 10%; $V_{IN} = 5V$		50		nS
$T_{HS\_ON\_OFF}$	High Side Gate Drive rise and Fall times	$C_L = 3nF$ ; 10 – 90%, 90 – 10%; $V_{IN} = 5V$		150		nS
<b>Input Current Sense</b>						
$V_{SEN\_OFST}$	Amplifier offset voltage	Measured at $ISNS\_OUT$ pin; $ISNS\_H = ISNS\_L$		0.6		V
$I_{SENACC\_TYP}^2$	Measured Current sense accuracy – typical current	$V_{R\_ISEN} = 25mV$ , $I = 1.25A$		$\pm 3.5$		%
<b>Analog to Digital Converter</b>						
N	Resolution			12		Bit
Channel	Number of channels			10		
$V_{IN\_FS}$	Full scale Input voltage			2.4		V
<b>LDO18<sup>3,4</sup> - <math>C_{OUT} = 1\mu F</math>; <math>V_{IN\_LDO} = 5.5V</math></b>						
$V_{OUT18}$	Output voltage		1.71	1.8	1.89	V
$\Delta V_{OUT}/V_{OUT}$	Output voltage accuracy			$\pm 5$		%
$I_{OUT18\_MAX}$	Maximum load current			10		mA
<b>LDO33<sup>4,3</sup> - <math>C_{OUT} = 1\mu F</math>; <math>V_{IN\_LDO} = 5.5V</math></b>						
$V_{OUT33}$	Output voltage	Programmable; Default setting=3.3V	3.15	3.3	3.45	V
$\Delta V_{OUT}/V_{OUT}$	Output voltage accuracy			$\pm 5$		%
$I_{OUT33\_MAX}$	Maximum Output Current			20		mA
<b>Thermal Shutdown</b>						
$T_{SD}$	Thermal shutdown	Threshold Rising		140		$^\circ C$
		Threshold Falling		120		$^\circ C$

# SPECIFICATION TABLE

**Table 4. Device Characteristic (Continued)**
 $V_{IN} = 12V$ ,  $V_{DDIO} = 3.3V$ ,  $E\bar{N} = 0V$ , medium power coil configuration,  $T_A = -40$  to  $+85^\circ C$ . Typical values are at  $25^\circ C$ , unless otherwise noted.

Symbol	Description	Conditions/Notes	Min	Typical	Max	Units
<b>Clock Oscillators</b>						
$F_{LSOSC}$	Low speed clock			50		KHz
$F_{CLOCK}$	OSC clock frequency			6		MHz
$F_{CENTER}^4$	PLL VCO frequency			240		MHz
<b>General Purpose Inputs/Outputs (GPIO)</b>						
$V_{IH}$	Input high voltage		$0.7 \cdot V_{DDIO}$			V
$V_{IL}$	Input low voltage				$0.3 \cdot V_{DDIO}$	V
$I_{LKG}$	Leakage Current		-1.0		1.0	$\mu A$
$V_{OH}$	Output logic high	$I = 8mA$	2.4			V
$V_{OL}$	Output logic low	$I = 8mA$			0.5	V
<b>SCL, SDA (I<sup>2</sup>C Interface)</b>						
$f_{SCL\_MSTR}$	Clock Frequency	As I <sup>2</sup> C master		400		kHz
$f_{SCL\_SLV}$	Clock Frequency	As I <sup>2</sup> C slave		400		kHz
$C_B$	Capcitive load	For each bus line			100	pF
$C_{BIN}$	SCL, SDA Input Capacitance			5.0		pF
$I_{LKG}$	Leakage Current		-1.0		1.0	$\mu A$

**NOTES:**

1. Input Voltage Operating Range is dependent upon the type of Transmitter Power Stage (full-bridge, half-bridge) and Transmitting Coil Inductance. WPC Specifications should be consulted for appropriate input voltage ranges by end product type.
2. A 20m $\Omega$ , 1% or better sense resistor and 4.7  $\Omega$ , 1% input filter resistor is required to meet the FOD specification.
3. Do not externally load. For internal biasing only.
4. Guaranteed by design and not subject to 100% production testing
5. This is the minimum IC operating specification. Full power transfer will not occur at this level.

# TYPICAL PERFORMANCE CHARACTERISTICS

Typical Performance Characteristics: System Efficiency versus RX Output Power  
 TA = 25°C

$$\text{System Efficiency (\%)} = \frac{(V_{OUT} \times I_{OUT}) \text{ Rx Output Power}}{(V_{IN} \times I_{IN}) \text{ Tx Input Power}} \times 100 (\%)\text{- Equation 1}$$

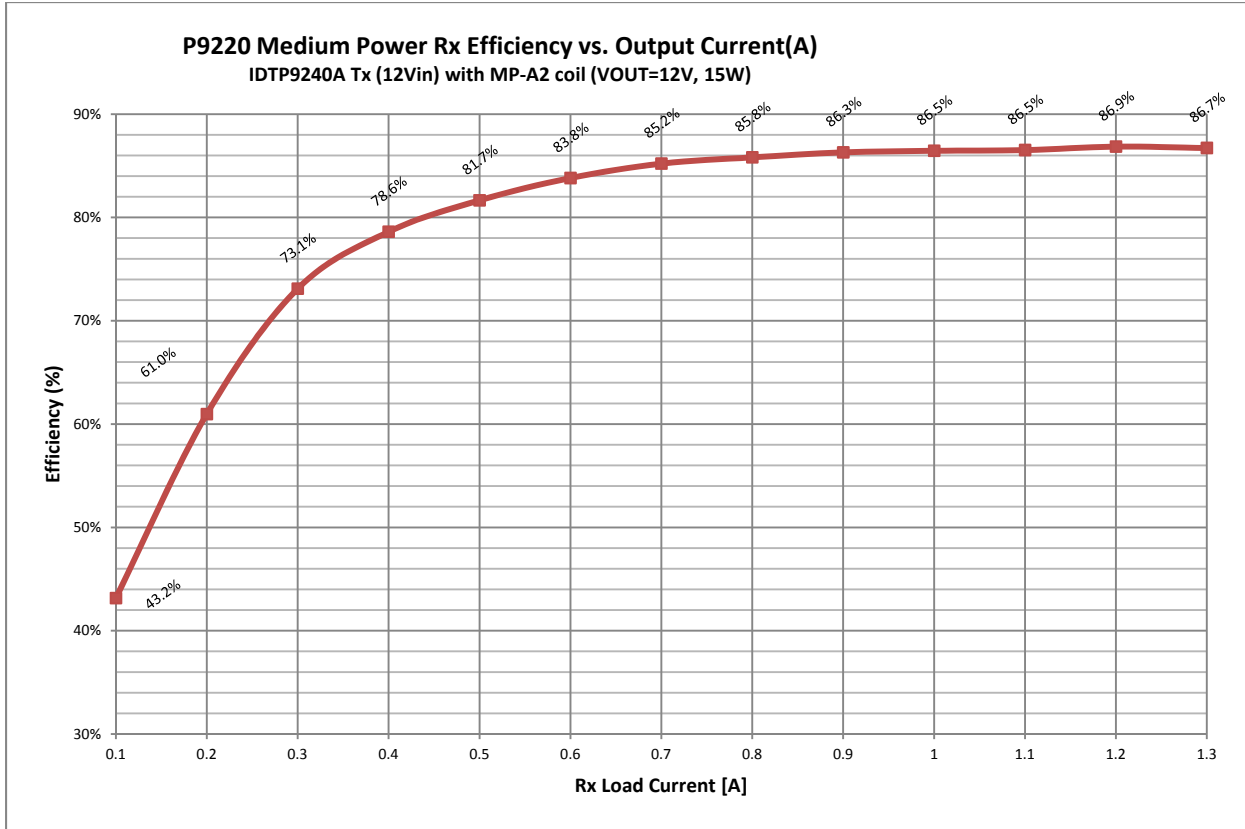

Figure 1. P9240A System Efficiency versus Output Power

# PIN CONFIGURATION AND DESCRIPTION

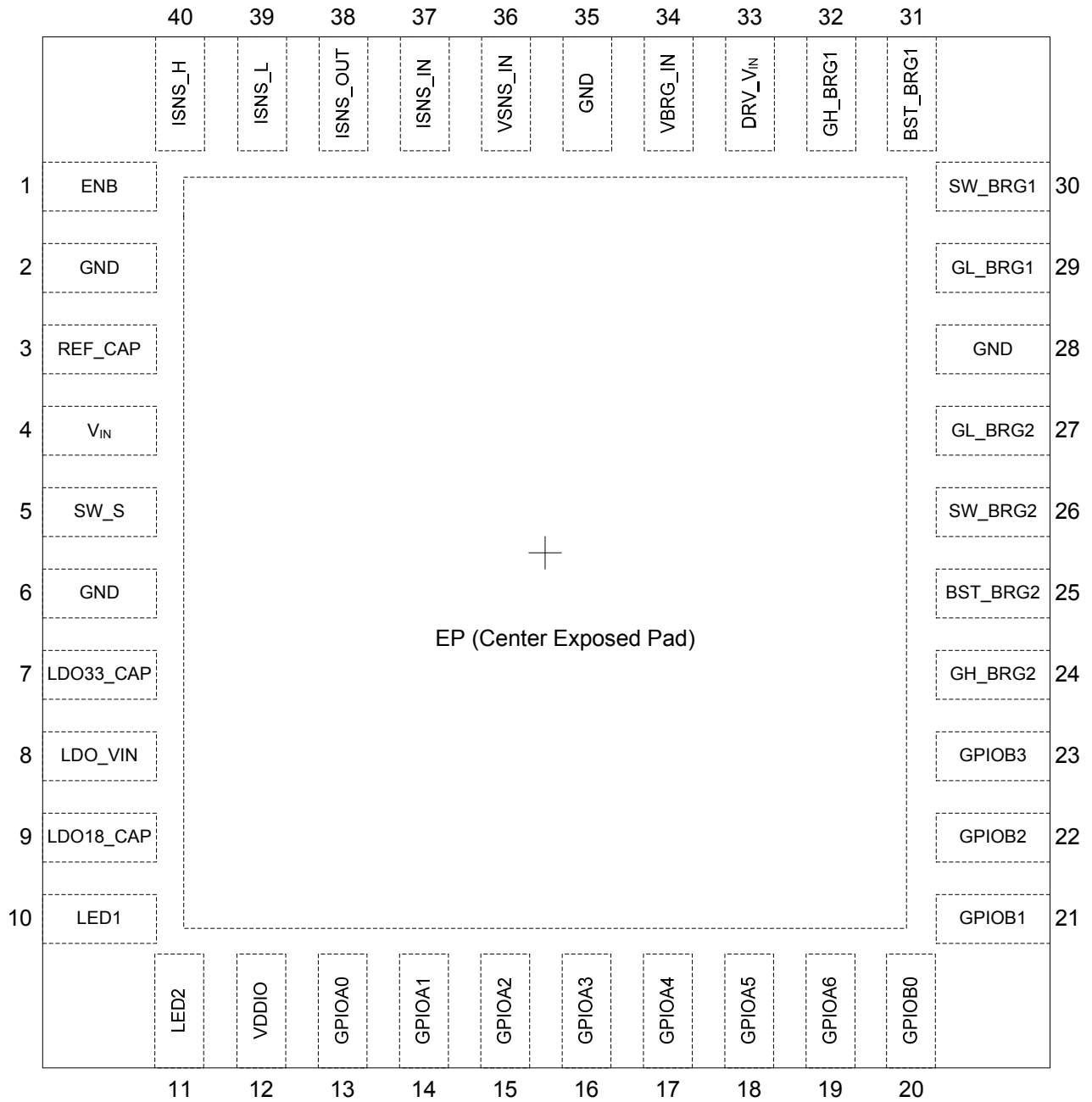

Figure 2. QFN-40 5mmx5mm (Top View)

Table 5. Pin Descriptions

PIN(s)	Name	Type	Function
1	ENB	I	Active low enable pin. When connected to logic high, the device shutdown and consumes less than 80 $\mu$ A of current. When connected to logic low, the device is in normal operation.
2, 6, 28, 35	GND	-	Ground connection.
3	REF_CAP	O	Regulated output voltage for the internal power management. Provides power for the entire power management block after the device has been shutdown (ENB= logic high). Connect a 1 $\mu$ F capacitor from this pin to ground. This pin should not be externally loaded.
4	V <sub>IN</sub>	I	Input power supply. Connect a 10 $\mu$ F capacitor from this pin to ground.
5	SW_S	O	Step-down regulator switch node. Connect one of the terminals of the 4.7 $\mu$ H inductor to this pin.
7	LDO33_CAP	O	Regulated 3.3V output voltage used for internal device biasing. Connect a 1 $\mu$ F capacitor from this pin to ground. This pin should not be loaded. Other available output voltage options are: 3.6, 3.9 and 4.2V. Consult factory for different voltage setting.
8	LDO_VIN	I	Low Dropout input power supply. Connected this pin to the output of the step-down regulator.
9	LDO18_CAP	I/O	Regulated 1.8V output voltage used for internal device biasing. Connect a 1 $\mu$ F capacitor from this pin to ground. This pin should not be externally loaded.
10, 11	LED1, LED2	I	Open drain output. Connect the LED's to these two pins.
12	VDDIO	I	Input power supply for both GPIO A and B. Can be connected to a power supply ranging from 1.8 – 5.0V.
15,16, 17,18,19	GPIOA [2:6]	I/O	Bank A general purpose input/output. The GPIO's power are supplied from VDDIO pin.
13,14	GPIOA [0:1]	I/O	GPIOA 0 – 1 default settings are SDA and SCL, respectively, for I <sup>2</sup> C interface.
20, 21, 22, 23	GPIOB [0:3]	I/O	Bank B general purpose input/output. The GPIO's power are supplied from VDDIO pin.
24	GH_BRG2	O	Gate driver output for the high-side half bridge 2.
25	BST_BRG2	I	Bootstrap pin for half Bridge 2. Tie an external capacitor from this pin to the SW_BRG2 to generate drive voltage higher the input voltage.
26	SW_BRG2	O	Switch node for half bridge 2.
27	GL_BRG2	O	Gate driver output for the low-side half bridge 2.
29	GL_BRG1	O	Gate driver output for the low-side half bridge 1.
30	SW_BRG1	O	Switch node for half bridge 1.
31	BST_BRG1	O	Bootstrap pin for half Bridge 1. Tie an external capacitor from this pin to the SW_BRG1 to generate drive voltage higher the input voltage.
32	GH_BRG1	O	Gate driver output for the high-side half bridge 1.
33	DRV_VIN	I	Input power supply for the internal gate drivers. Connect a 10 $\mu$ F capacitor from this pin to ground.
34	VBRG_IN	I	Bridge Voltage input sense.
36	VSNS_IN	I	Voltage sense input.
37	ISNS_IN	I	Current sense input.
38	ISNS_OUT	O	Input Current Sense output
39	ISNS_L	I	Input Current Sense Negative Input
40	ISNS_H	I	Input Current Sense Positive Input
	EPD	-	Expose pad. Thermal pad for heatsinking purposes. Connect EPD to GND plane.

# FUNCTIONAL BLOCK DIAGRAM

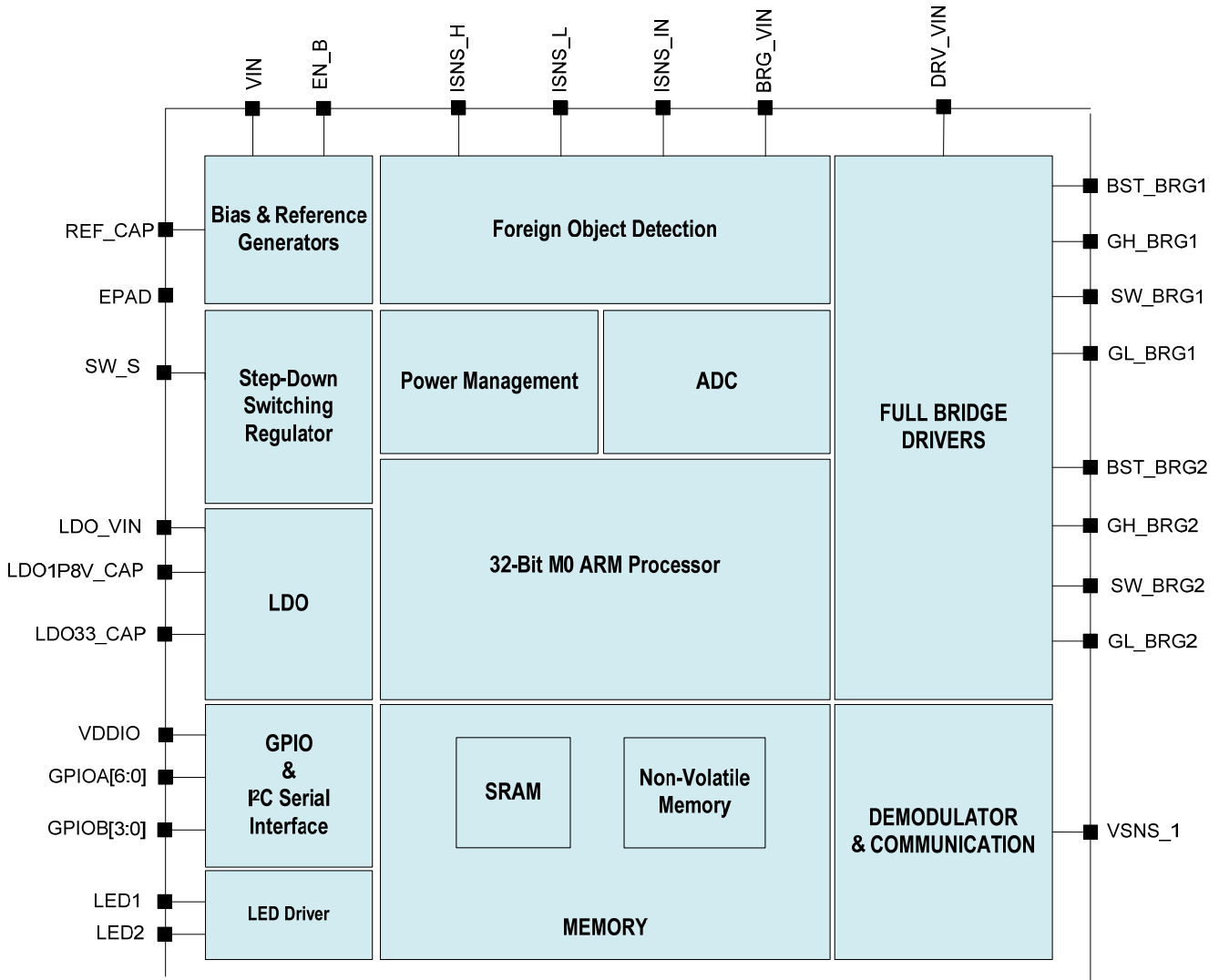

Figure 3. P9240A Block Diagram

## Description of the Wireless Power Charging System

A wireless power charging system has a base station with one or more transmitters that make power available via DC-to-AC inverter(s) and transmit the power over a strongly-coupled inductor pair to a receiver in a portable device. A WPC<sup>1</sup> transmitter may be a *free-positioning* or *magnetically-guided* type. A *free-positioning* type of transmitter has one or more coils that gives limited spatial freedom to the end-user, whereas a *magnetically-guided* type of transmitter helps the end-user align the receiver to the transmitter with a magnetic attraction.

The amount of power transferred to the portable device is controlled by the receiver. The receiver sends communication packets to the transmitter to increase power, decrease power, or maintain the power level. The communication is purely digital, and communication 1's and 0's ride on top of the power link that exists between the two coils.

A large part of the efficiency of the wireless charging system arises from the fact that when it's not actually charging a tablet device, the transmitter is in a very-low-power sleep mode. Until the transmitter detects the presence of a receiver, it remains in a low-power state.

## Theory of Operation

The P9240A is a highly-integrated wireless power transmitter IC solution for tablet devices. It can transfer up to 15W of power in WPC mode, from a wireless transmitter to a load (e.g., a battery charger) using near-field magnetic induction.

## OVERVIEW

The simplified block diagram of the P9240A is shown in Figure 3 and contains the following functions:

- Optimized and fully supports WPC transmitter specification.
- Supports WPC low power transmitter types.
- Powerful 32 bit ARM® Cortex®-M0 processor, with SRAM and OTP for data memory and OTP and supports FLASH memory for field updated-able programming.
- Supports high speed serial flash (SPI interface) for system development, chip bring up and debug.
- Dithered PWM controller for high resolution voltage modulation.
- Multiple new and enhanced demodulation schemes using less external components for robust communication.
- Built-in I<sup>2</sup>C interface to communicate with external devices.
- Built-in PLL and clock synthesizer for PWM generation and bi-directional communication.
- Support variable logic I/O voltages with dedicated VDDIO pin.
- Built-in general purpose 12 bit, 100 KSPS ADC for temperature, voltage, current measurement and processing.
- Two banks of GPIO's with dedicated power supply.

**Note 1** - Refer to the WPC specification at <http://www.wirelesspowerconsortium.com/> for the most current information

# DETAILED SYSTEM DIAGRAM

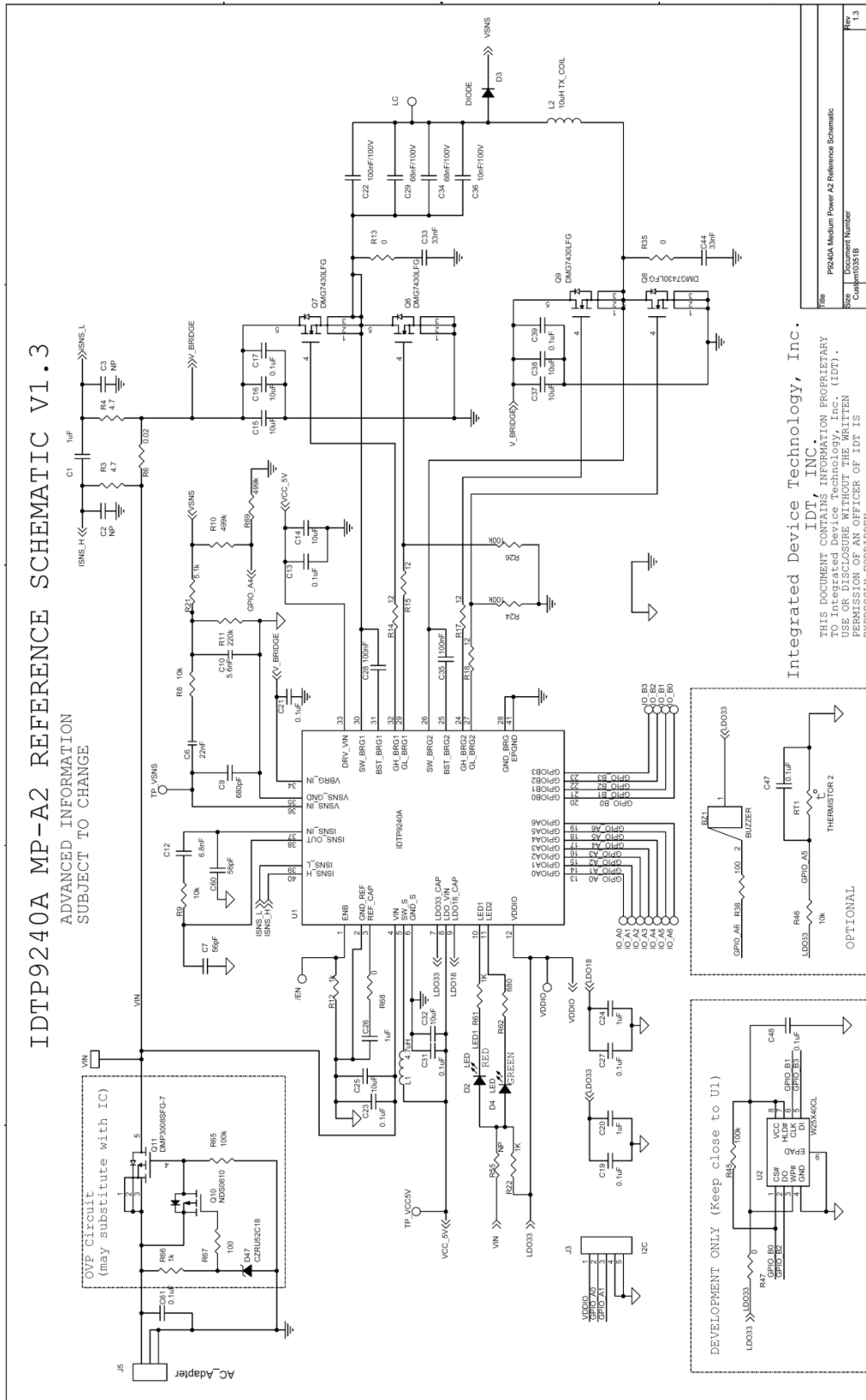

Figure 4. P9240A Preliminary WPC Reference Design Schematic

File	P9240A Medium Power A2 Reference Schematic
Size	Document Number
Client	Client#0518
Date	Friday, February 19, 2016
Sheet	1 of 1
Rev	1.3

Integrated Device Technology, Inc.  
 IDT, INC.  
 THIS DOCUMENT CONTAINS INFORMATION PROPRIETARY TO Integrated Device Technology, Inc. (IDT). USE OR DISCLOSURE WITHOUT THE WRITTEN PERMISSION OF AN OFFICER OF IDT IS EXPRESSLY FORBIDDEN

# COMPONENTS SELECTION

**Table 6. Component List**

P9240A Medium Power A2 Reference Schematic Revised: Friday, January 29, 2016					
10351B Revision: 1.3					
Item	Quantity	Reference	Part Number	Part	PCB Footprint
1	4	C1,C20,C24,C26	CL05A105MP5NNNC	1uF	402
2	1	C6	C1608X7R1H223K	22nF	603
3	2	C7,C60	CL05C560JB5NNNC	56pF	402
4	1	C9	CL05B681KB5NNNC	680pF	402
5	1	C10	GRM155R71E562KA01D	5.6nF	402
6	1	C12	GRM155R71E682KA01D	6.8nF	402
7	4	C13,C19,C27,C31	LMK105BJ104KV-F	0.1uF	402
8	1	C14	CL10A106MA8NRNC	10uF	402
9	5	C15,C16,C25,C37,C38	CL10A106MA8NRNC	10uF	603
10	5	C17,C21,C23,C39,C61	TMK105BJ104KV-F	0.1uF	402
11	1	C22	C3216C0G2A104J160AC	100nF/100V	1206
12	2	C28,C35	C1005X6S1V104K050BB	100nF	402
13	2	C29,C34	C3216C0G2A683K160AC	68nF/100V	1206
14	1	C32	LMK107BBJ106MAHT	10uF	603
15	2	C33,C44	TMK105BJ333KV-F	33nF	402
16	1	C36	C3216C0G2A103J115AA	10nF/100V	1206
17	1	D3	BAV21W-7-F	DIODE	sod123
18	1	D47	CZRU52C18	CZRU52C18	0603_diode
19	8	IO_A0,IO_A1	NP	PTH_TP	tp_25mil
20	1	J5	PJ-002BH	AC Adapter	CONN_POWER JACK5_5MM
21	1	L1	CIG10W4R7MNC	4.7uH	603
22	1	L2	SWA53N53H30C11B	10uH TX_COIL	IND_A11_TX_COIL_SMD
23	4	Q6,Q7,Q8,Q9	DMG7430LFG	DMG7430LFG	powerdi3333_8ld_fet
24	1	Q10	NDS0610	NDS0610	SOT23_3
25	1	Q11	DMP3008SFG-7	DMP3008SFG-7	powerdi3333_8ld_fet
26	2	R3,R4	ERJ-2GEJ4R7X	4.7	402
27	1	R6	WSL0805R0200FEA	0.02	805
28	2	R8,R9	CRCW040210K0JNED	10k	402
29	2	R10,R69	RC0402FR-07499KL	499k	402
30	1	R11	RC0402FR-07220KL	220k	402
31	4	R12,R22,R61,R66	RC0402JR-071KL	1k	402
32	3	R13,R35,R68	RC0402JR-070RL	0	402
33	4	R14,R15,R17,R18	ERJ-2GEJ120X	12	402
34	1	R21	MCR01MRTJ512	5.1k	402
35	3	R24,R26,R65	ERJ-2GEJ104X	100k	402
36	1	R55	TBD	NP	402
37	1	R62	RC0402JR-07680RL	680	402
38	1	R67	ERJ-2GEJ101X	100	402
39	1	U1	P9240A	IDTP9240A	qfn_40ld_5x5mm_3p75therm
<b>OPTIONAL:</b>					
40	8	IO_A4,TP_VCC5V,IO_A5, IO_A6,VDDIO,TP_VSNS,LC, /EN		PTH_TP	80-40pth
41	1	BZ1	PS1240P02CT3 (Optional)	BUZZER	buzz_ps1240
42	2	C2,C3		NP	603
43	2	C47,C48	LMK105BJ104KV-F	0.1uF	402
44	1	D2	150 060 RS7 500 0	LED	0603_diode
45	1	D4	150 060 GS7 500 0	LED	0603_diode
46	6	IO_B1,IO_B2,IO_A2, IO_B3,IO_A3,IO_B0		PTH_TP	tp_25mil
47	1	J3	68002-205HLF	I2C	header_1x5_0p1Pitch50p31d
48	1	RT1		THERMISTOR 2	805
49	1	R38	ERJ-3GEYJ101V	100	603
50	1	R45	ERJ-2GEJ104X	100k	402
51	1	R46	MCR01MRTJ103	10k	402
52	1	R47	RC0402JR-070RL	0	402
53	1	U2	W25X40CLUXIG	W25X40CL	uson_2x3_8LD
54	1	VIN	5015	Test Point_SM	test_pt_sm_135x70

# APPLICATIONS INFORMATION

## EXTERNAL COMPONENTS

The P9240A requires a minimum number of external components for proper operation, as indicated in Figure 4 and Table 6.

### OTP, EXTERNAL FLASH, and SRAM

The P9240A uses OTP (256kbits) which is field programmable using GPIO\_A0 (SCL) and GPIO\_A1 (SDA) and follows I<sup>2</sup>C communications protocols. Once the device is powered the firmware settings that have been burned into the OTP are executed based on the hex file that has been programmed into memory. For development and applications that may require updates to operation a FLASH memory should be utilized. The Flash will allow multiple time programming. If the Flash is not present, the P9240A will load and execute the OTP contents. Either OTP or FLASH memory must be programmed prior to startup for proper operation. The Flash IC should be connected to the P9240A as shown in Figure 4. SRAM is used by the device to temporarily store and retrieve data during device operation.

### BUCK REGULATOR

The input capacitors (C<sub>VIN</sub>) must be connected directly between the power pin (VIN) and power GND pin (Pin 6) and placed as close as possible to the respective IC pins. The output capacitor (C<sub>VCC\_5V</sub>) must be placed close to the device and power ground pin (GND pin 6). The output voltage is sensed by the LDO\_VIN pin; therefore, the connection from the BUCK output (VCC\_5V) to the LDO\_VIN pin should be made as wide and short as possible to minimize output voltage errors. The BUCK regulator operates in hysteretic pulse mode to set the output voltage and will regulate the VCC\_5V node near 5.1V when VIN is greater than 5.5VDC. If VIN is less than 5.5V, the BUCK output will decrease below 5.1V, and when the VIN is less than 5.1V, the regulator will switch to linear mode and operate similar to an LDO regulator. Since the BUCK regulator provides power for internal functions, such as the gate drivers along with the LDO18 and LDO33 circuits it is important to select an appropriately rated inductor for use to generate the regulated voltage with acceptable output ripple. It is not recommended to use an inductor less than 4.7μH.

## INDUCTOR SELECTION

To simplify the selection of inductors, the following approximations and equations should be used.

$$I_{PEAK\_startup} = I_{PEAK} + \Delta I \text{ (A)}, \quad \text{Equation 1}$$

where, I<sub>PEAK</sub> = peak current that flows through the BUCK inductor during device startup. The maximum peak current is limited internally and can be as high as 300mA.

The following equations can be used to determine the inductor minimum current ratings.

$$I_{MAX} = I_{OUT} + \Delta I \text{ (A)}, \quad \text{Equation 2}$$

where, I<sub>MAX</sub> = the peak current during operation

I<sub>OUT</sub> = the average load current (sum of any external load on the BUCK output up to 50mA and the internal loading (~25mA maximum, 10mA typical)

ΔI = the positive inductor ripple current

$$\Delta I = \frac{(VIN - VCC\_5V) \times t_{BLANK}}{L} \text{ (A)}, \quad \text{Equation 3}$$

where, L = Inductance (μH)

t<sub>BLANK</sub> = time the High-Side BUCK switch is on. The hysteresis mode is time controlled based on the VCC\_5V voltage. Once the High-side BUCK switch is triggered (VCC\_5V = 5.1V) the 80ns (t<sub>BLANK</sub>, 100ns maximum) blanking timer starts. To eliminate consecutive blanking pulses a 100ns (120ns maximum) hysteretic timer is in place. The blanking timer and hysteresis timer are based on the same clock; therefore, they can never overlap.

The inductor rated current should be chosen to exceed the greater value of I<sub>MAX</sub> or I<sub>PEAK\_startup</sub> and the saturation current should be higher than I<sub>MAX</sub>. The DCR should be kept to a minimum to improve the efficiency of the regulator.

## OUTPUT CAPACITOR

The output capacitor should be assigned based on the typical reference schematic to avoid control loop stability errors and should not be less than 20μF. For applications that require lower ripple voltage levels or have transient

## APPLICATIONS INFORMATION (CONTINUED)

loads, additional capacitance may be added in order to meet voltage ripple requirements. Low ESR ceramic capacitors are recommended.

### OVERVIEW OF GPIO USAGE

There are 2 banks of GPIOs on the P9240A transmitter IC. The GPIOs are controlled by OTP or by FLASH. Some of the GPIOs are semi-dedicated for specific operations as described below:

- GPIO\_A0: This pin is used as SCL for I<sup>2</sup>C communication, can be connected to the ADC, or can be used as a digital I/O.
- GPIO\_A1: This pin is used as SDA for I<sup>2</sup>C communication, can be connected to the ADC, or can be used as a digital I/O.
- GPIO\_A4: This pin is used to enter debug mode, can be connected to the ADC, or can be used as a digital I/O.
- GPIO\_B0: This pin is used for CS function with Flash or as a digital I/O.
- GPIO\_B1: This pin is used for SCK function with Flash or as a digital I/O.
- GPIO\_B2: This pin is used for MISO function with Flash or as a digital I/O.
- GPIO\_B3: This pin is used for MOSI function with Flash or as a digital I/O.
- GPIO\_A0 – GPIO\_A5: These pins may be configured to connect to the ADCs or as digital I/Os.
- All GPIO pins can be configured to be used as digital I/Os.

For additional usage or questions on capabilities, consult the factory.

### LDOs

#### INPUT CAPACITOR

The input capacitors should be located as close as possible to the power pin, LDO\_VIN and ground (EPD GND). Ceramic capacitors are recommended for their lower ESR and small profile. The recommended external components are shown in Table 6.

#### OUTPUT CAPACITOR

For proper load voltage regulation and operational stability, a capacitor is required on the output of each LDO (LDO18 and LDO33). The output capacitor connection to the ground pin (GND EPD and pin 6) should be made as short as practical for optimal device performance. Since the LDOs have been designed to function with very low ESR capacitors, a ceramic capacitor is recommended for best performance.

#### WPC TX Coil

When used in the WPC Medium power MP-A1 or MP-A2 full-bridge configuration, each half-bridge output connects to a series-resonance circuit made by a WPC Type-MP-A1/MP-A2 coil and series resonance capacitors. The inductor serves as the primary coil of a loosely-coupled transformer, the secondary of which is the inductor connected to the power receiver (IDTP9220 or another).

The TX power transmitter coils are mounted on a ferrite base acting as a shield to concentrate the field on the top side of the coil and to reduce EMI. The coil assembly can be mounted next to the P9240A. Either a ground plane or grounded metal shielding (preferably copper) can be added beneath the ferrite shield for added reduction in radiated electrical field emissions. The coil ground plane/shield should be connected to the ground plane by a single trace leading back independently to the board input power connector.

#### ADC CONSIDERATIONS

GPIO\_A0 through GPIO\_A5 can be connected internally to successive-approximation ADCs via a multiplexed input. All GPIOs maintain the full 12 bit resolution.

The GPIO pins that are connected to the ADC have limited input range, so attention should be paid to the maximum full-scale input voltage (2.4V). Decoupling capacitors with a value of 0.1μF can be added to minimize noise.

## APPLICATIONS INFORMATION (CONTINUED)

### DECOUPLING/BULK CAPACITORS

As with any high-performance mixed-signal IC, the P9240A must be isolated from the system power supply noise to perform optimally. A decoupling capacitor of 0.1 $\mu$ F must be connected between each power supply pin and the PCB ground plane and placed as close as possible to these pins. For optimal device performance, the decoupling capacitor must be mounted on the component side of the PCB. Additionally, at least one 10 $\mu$ F capacitor should be placed at the VIN pin and two 10 $\mu$ F capacitors should be placed across each half-bridge used to convert DC to AC for power transfer to minimize ripple voltage and voltage droop due to the large current requirements. These 10 $\mu$ F capacitors must be connected as close as possible to the respective pins. The effective value of the capacitors will derate due to applied voltage. For example, a 10 $\mu$ F X5R 25V capacitor's value is actually 6 $\mu$ F when operating at 10V, depending on the manufacturer. The effective capacitance of each 10 $\mu$ F capacitor should be maintained above 6 $\mu$ F during operation for optimal performance.

### PCB LAYOUT CONSIDERATIONS

For optimum device performance and lowest output noise, the following guidelines should be observed. Please contact IDT Inc. for Gerber files that contain the recommended board layout and application note AN917, "P9240A MP Layout Guidelines".

- As with all switching power supplies, especially those providing high current, layout is an important design step. If layout is not carefully done, the regulator or inverter could show instability as well as cause EMI problems. Therefore, use wide and short traces for high current paths.
- An optimal layout is one with all components on the same side of the board, minimizing high power signals transitions to other layers. Other signal traces should be routed away from the P9240A Bridge Inverters. This includes signal traces just underneath the device, or on layers adjacent to the ground plane layer used by the device
- Layout and PCB design have a significant influence on the power dissipation capabilities of power management ICs because the surface mount packages used with these devices rely heavily on thermally conductive traces or pads to transfer heat

away from the package. Appropriate PC layout techniques should be used to remove the heat due to device power dissipation.

- The following general guidelines will be helpful in designing a board layout for lowest thermal resistance:
  1. PC board traces with large cross-sectional areas remove more heat. For optimal results, use large-area PCB patterns with wide copper traces, placed on the component side of the PCB.
  2. In cases where maximum heat dissipation is required, use double-sided copper planes connected with multiple vias.
  3. Thermal vias are needed to provide a thermal path from the bridge FETs to inner and/or bottom layers of the PCB to remove the heat generated by device power dissipation.

### POWER DISSIPATION AND THERMAL REQUIREMENTS

The P9240A is offered in a TQFN-40 package for which has a maximum power dissipation capability of about 1.4W, the maximum power dissipation of which is determined by the number of thermal vias between the package and the printed circuit board. The maximum power dissipation of either package is defined by the die's specified maximum operating junction temperature,  $T_{J(MAX)}$  of 125°C. The junction temperature rises when the heat generated by the device's power dissipation flows through the package thermal resistance. The TQFN package offers a typical thermal resistance, junction to ambient ( $\Theta_{JA}$ ), of 28.5°C/W when the PCB layout guideline and surrounding devices are optimized as described in the PCB Layout Considerations section. The techniques as noted in the PCB layout section must be followed when designing the printed circuit board layout. Attention to the placement of the P9240A IC and bridge FET packages in proximity to other heat-generating devices in a given application design should also be considered. The ambient temperature around the power IC will also have an effect on the thermal limits of an application. The main factors influencing  $\Theta_{JA}$  (in the order of decreasing influence) are PCB characteristics, die/package attach thermal pad size (TQFN) and thermal vias and final system hardware construction. Board designers should keep in mind that the package thermal metric  $\Theta_{JA}$  is impacted by the characteristics of the PCB itself upon

## APPLICATIONS INFORMATION (CONTINUED)

which the IC is mounted. Changing the design or configuration of the PCB changes the overall thermal resistivity and the board's heat-sinking efficiency.

The use of integrated circuits in low-profile and fine-pitch surface-mount packages requires special attention to power dissipation. Many system-dependant issues such as thermal coupling, airflow, added heat sinks, convection surfaces, and the presence of other heat-generating components affect the power-dissipation limits of a given component.

In summary, the three basic approaches for enhancing thermal performance are listed:

1. Improving the power dissipation capability of the PCB design.
2. Improving the thermal coupling of the component to the PCB.
3. Introducing airflow into the system.

First, the maximum power dissipation for a given situation should be calculated:

$$P_{D(MAX)} = (T_{J(MAX)} - T_A) / \theta_{JA}$$

In which

$P_{D(MAX)}$  = Maximum Power Dissipation

$\theta_{JA}$  = Package Thermal Resistance (°C/W)

$T_{J(MAX)}$  = Maximum Device Junction Temperature (°C)

$T_A$  = Ambient Temperature (°C)

The maximum recommended operating junction temperature ( $T_{J(MAX)}$ ) for the P9240A device is 125°C. The thermal resistance of the 40-pin TQFN package (NDG48) is optimally  $\theta_{JA}=28.5^{\circ}\text{C}/\text{W}$ . Operation is specified to a maximum steady-state ambient temperature ( $T_A$ ) of 85°C. Therefore, the maximum recommended power dissipation is:

$$P_{D(Max)} = (125^{\circ}\text{C} - 85^{\circ}\text{C}) / 28.5^{\circ}\text{C}/\text{W} \cong 1.4 \text{ Watt.}$$

All the previously mentioned thermal resistances are the values found when the ICs are mounted on a standard board of the dimensions and characteristics specified by the JEDEC 51 standard.

### THERMAL PROTECTION

The P9240A integrates thermal overload shutdown circuitry to prevent damage resulting from excessive thermal stress that may be encountered under fault conditions. This circuitry will shut down or reset the device if the die temperature exceeds the thermal shutdown specification. To allow the maximum load current on and to prevent thermal overload it is important to ensure that the heat generated by the P9240A solution is dissipated into the PCB. All the available pins must be soldered to the PCB. GND pins (especially the E-PAD) and bridge FETs should be soldered to the PCB ground plane to improve thermal performance with multiple vias connected to all layers of the PCB. For the TQFN package the exposed paddle (EP) must be soldered to the PCB, with multiple vias evenly distributed under the package and exiting the bottom side of the PCB. This improves heat flow away from the package and minimizes package thermal gradients.

### SPECIAL NOTES

#### NDG TQFN-40 PACKAGE ASSEMBLY

Notes:

1. Unopened Dry Packaged Parts have a one year shelf life.
2. The HIC indicator card for newly-opened Dry Packaged Parts should be checked. If there is any moisture content, the parts must be baked for a minimum of 8 hours at 125°C within 24 hours prior to the assembly reflow process.

PACKAGE OUTLINE DRAWING

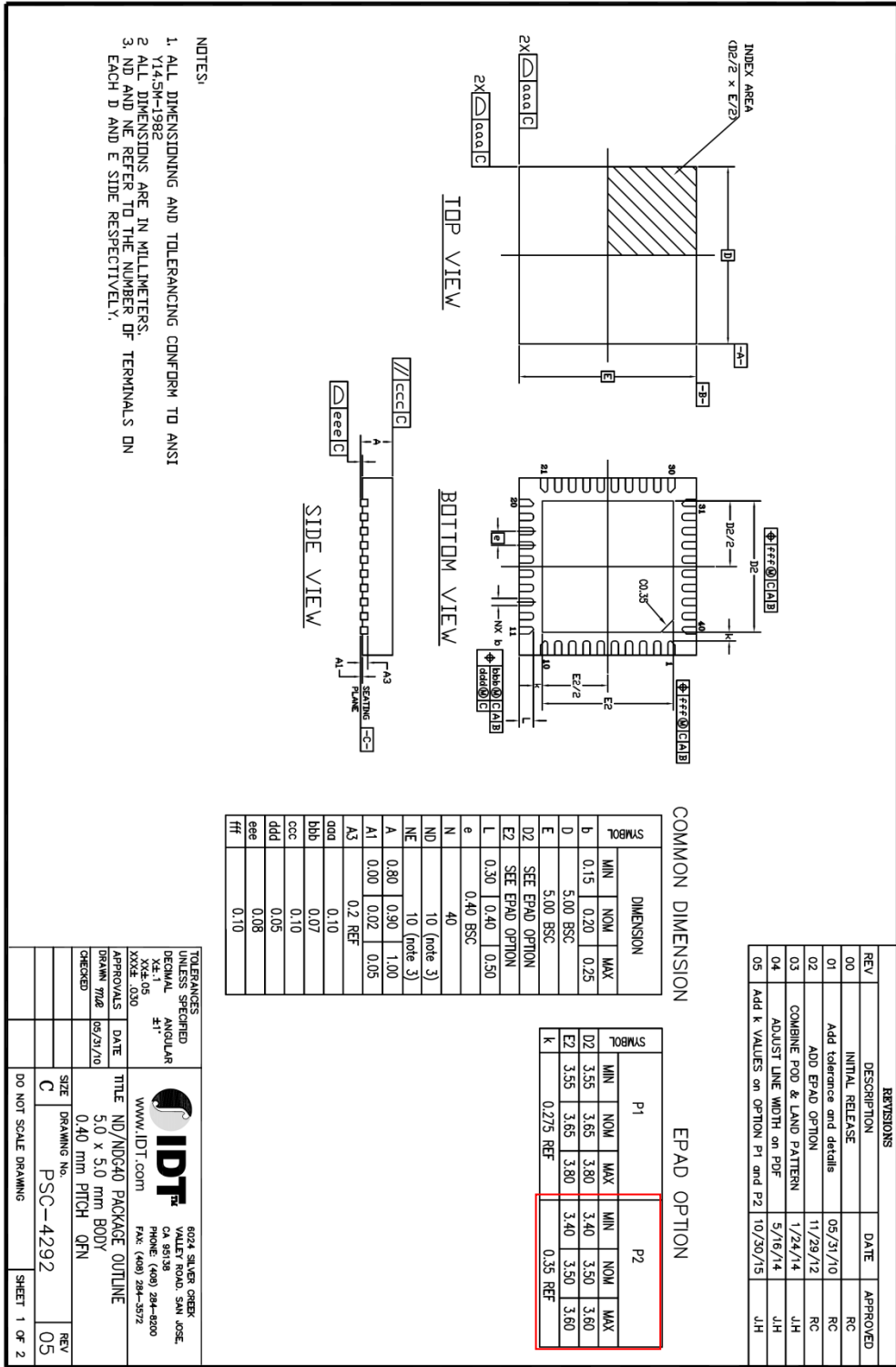

Figure 5. QFN-40 NDG40 5mmx5mm Package Outline Drawing (POD). P9240A uses Option P2.

# LANDING PATTERN DRAWING

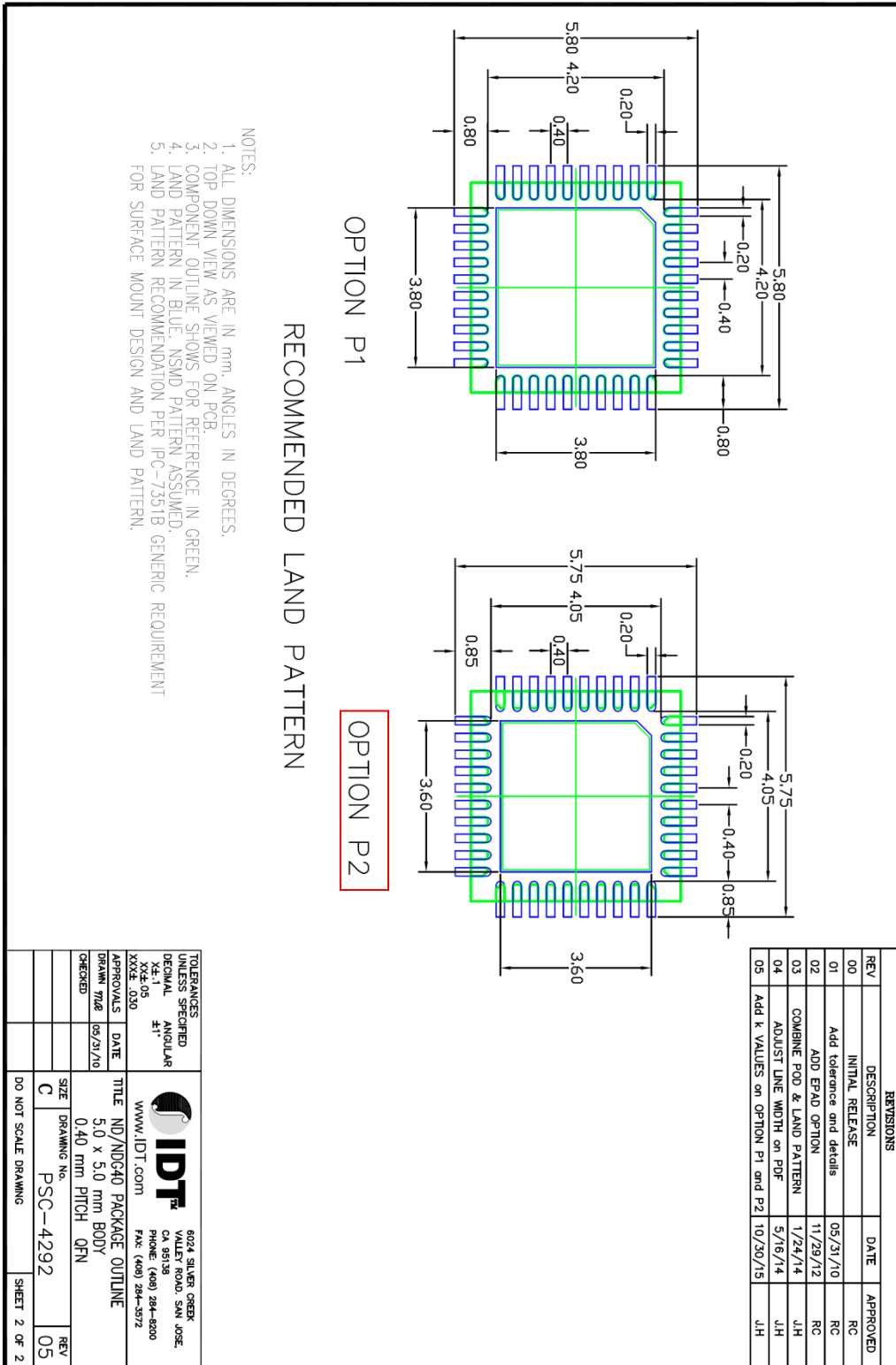

Figure 7: QFN-40 NDG40 Landing Pad Drawing

# ORDERING GUIDE

Table 7. Ordering Summary

PART NUMBER	MARKING	PACKAGE	AMBIENT TEMP. RANGE	SHIPPING CARRIER
P9240A-0*NDGI	P9240A-0*NDGI	NDG40 - QFN-40 5x5x0.40	-40°C to +85°C	Tray
P9240A-0*NDGI8	P9240A-0*NDGI	NDG40 - QFN-40 5x5x0.40	-40°C to +85°C	Tape and reel

\*Note – this field is a custom value that is specific to each customer. Please contact your local sales team for your particular value for this field.

## IMPORTANT NOTICE AND DISCLAIMER

RENESAS ELECTRONICS CORPORATION AND ITS SUBSIDIARIES (“RENESAS”) PROVIDES TECHNICAL SPECIFICATIONS AND RELIABILITY DATA (INCLUDING DATASHEETS), DESIGN RESOURCES (INCLUDING REFERENCE DESIGNS), APPLICATION OR OTHER DESIGN ADVICE, WEB TOOLS, SAFETY INFORMATION, AND OTHER RESOURCES “AS IS” AND WITH ALL FAULTS, AND DISCLAIMS ALL WARRANTIES, EXPRESS OR IMPLIED, INCLUDING, WITHOUT LIMITATION, ANY IMPLIED WARRANTIES OF MERCHANTABILITY, FITNESS FOR A PARTICULAR PURPOSE, OR NON-INFRINGEMENT OF THIRD-PARTY INTELLECTUAL PROPERTY RIGHTS.

These resources are intended for developers who are designing with Renesas products. You are solely responsible for (1) selecting the appropriate products for your application, (2) designing, validating, and testing your application, and (3) ensuring your application meets applicable standards, and any other safety, security, or other requirements. These resources are subject to change without notice. Renesas grants you permission to use these resources only to develop an application that uses Renesas products. Other reproduction or use of these resources is strictly prohibited. No license is granted to any other Renesas intellectual property or to any third-party intellectual property. Renesas disclaims responsibility for, and you will fully indemnify Renesas and its representatives against, any claims, damages, costs, losses, or liabilities arising from your use of these resources. Renesas' products are provided only subject to Renesas' Terms and Conditions of Sale or other applicable terms agreed to in writing. No use of any Renesas resources expands or otherwise alters any applicable warranties or warranty disclaimers for these products.

(Disclaimer Rev.1.01)

### Corporate Headquarters

TOYOSU FORESIA, 3-2-24 Toyosu,  
Koto-ku, Tokyo 135-0061, Japan  
[www.renesas.com](http://www.renesas.com)

### Trademarks

Renesas and the Renesas logo are trademarks of Renesas Electronics Corporation. All trademarks and registered trademarks are the property of their respective owners.

### Contact Information

For further information on a product, technology, the most up-to-date version of a document, or your nearest sales office, please visit [www.renesas.com/contact-us/](http://www.renesas.com/contact-us/).