

Contents

1	Description.....	2
1.1.	General.....	2
1.2.	ZSSC3131 and ZSSC3136 Sensor Conditioners.....	2
1.3.	Benefits for Automotive Switch Applications	2
2	Setting up the ZSSC3131/36 for Switching Applications	3
2.1.	Threshold with Offset and Hysteresis.....	3
2.2.	Alarm Window.....	6
2.3.	Digital Filter.....	7
2.4.	Fast or Slow Switches	8
3	Application Circuits.....	9
4	Related Documents.....	11
5	Glossary	11
6	Document Revision History.....	12

List of Figures

Figure 2.1	Calibration Window.....	3
Figure 2.2	Switch Implementation.....	4
Figure 2.3	Switch with Hysteresis	5
Figure 2.4	Switch Setting Example	5
Figure 2.5	Sensor Range Correction	6
Figure 3.1	Sensor Switch Application Driving a Relay.....	9
Figure 3.2	Sensor Switch Application Connected to a Microcontroller.....	9
Figure 3.3	Alarm Window.....	10
Figure 3.4	Adding Hysteresis to the Output	10

List of Tables

Table 2.1	Alarm Window Operation using Two Comparators	6
Table 2.2	Fast vs. Slow Switch Setup	8

1 Description

1.1. General

This document describes how to setup switch applications based on the ZSSC3131 and ZSSC3136 sensor conditioners, using the ZSSC313x Graphic User Interface (GUI). ZSSC313x family ICs are designed for automotive and industrial sensor signal conditioning (SSC) applications requiring a high degree of accuracy, strong ESD protection, and EMC immunity.

Limit control is a common application for sensor switches, and it is an integral part of many sensing systems. Sensor switches have found many applications in automotive, industrial and consumer electronics.

Sensing parameters for the ZSSC3131/36 can be

- **Pressure**
- **Flow**
- **Force, torque, and acceleration**
- **Proximity and similar measurements**

Typical applications, especially automotive uses, include engine oil pressure measurement, hydraulic brake systems, brake lights, dust control applications, fuel level gauges, filter systems, feedback for gear selection, clutch controls, and many others. ZSSC313x ICs are also applicable in HVAC and cooling systems.

1.2. ZSSC3131 and ZSSC3136 Sensor Conditioners

The ZSSC3131 and the ZSSC3136 are part of the ZSSC313x product family for automotive applications featuring the following functionality:

- **Protection:** excellent electromagnetic behavior as well as **AEC-Q100** qualification.
- **Flexibility:** analog front-end (AFE) fits a wide range of sensors.
- **Output:** ratiometric analog voltage output between 5% and 95% of maximum 5.5V supply voltage.
- **Threshold and slew rate:** adjustable via EEPROM settings.
- **Safety:** features for meeting **SIL2** requirements (for ZSSC3136 only).

1.3. Benefits for Automotive Switch Applications

Many of the advantages of the ZSSC3131/36 are specifically designed for automotive sensor switch applications:

- All settings are stored in an internal EEPROM.
- High accuracy can be achieved because the sensor signal used to trigger the switch has been conditioned.
- Flexible analog front-end allows configuration for nearly all resistive bridge sensor elements.
- Both ZSSC3131 and ZSSC3136 have automotive qualification and integrated automotive protection circuits.
- Integrated safety functions allow setting up **SIL2**-rated switch applications using the ZSSC3136.

2 Setting up the ZSSC3131/36 for Switching Applications

The ZSSC3131/36 output pin 9 (AOUT) is an analog voltage output within the range of 5% to 95% of the supply voltage VDDE. Depending on the calibration setup used, this output can have the functionality of either a ratio-metric output voltage or of a switch (Alarm).

For using the ZSSC3131/36 with ratiometric voltage output, the normal calibration procedure is used (see the *ZSSC313x Evaluation Kit Description* for details).

For switch configuration, refer to the following sections for setting the critical switch parameters. These settings refer to a linear calibration procedure (two-point calibration).

Figure 2.1 Calibration Window

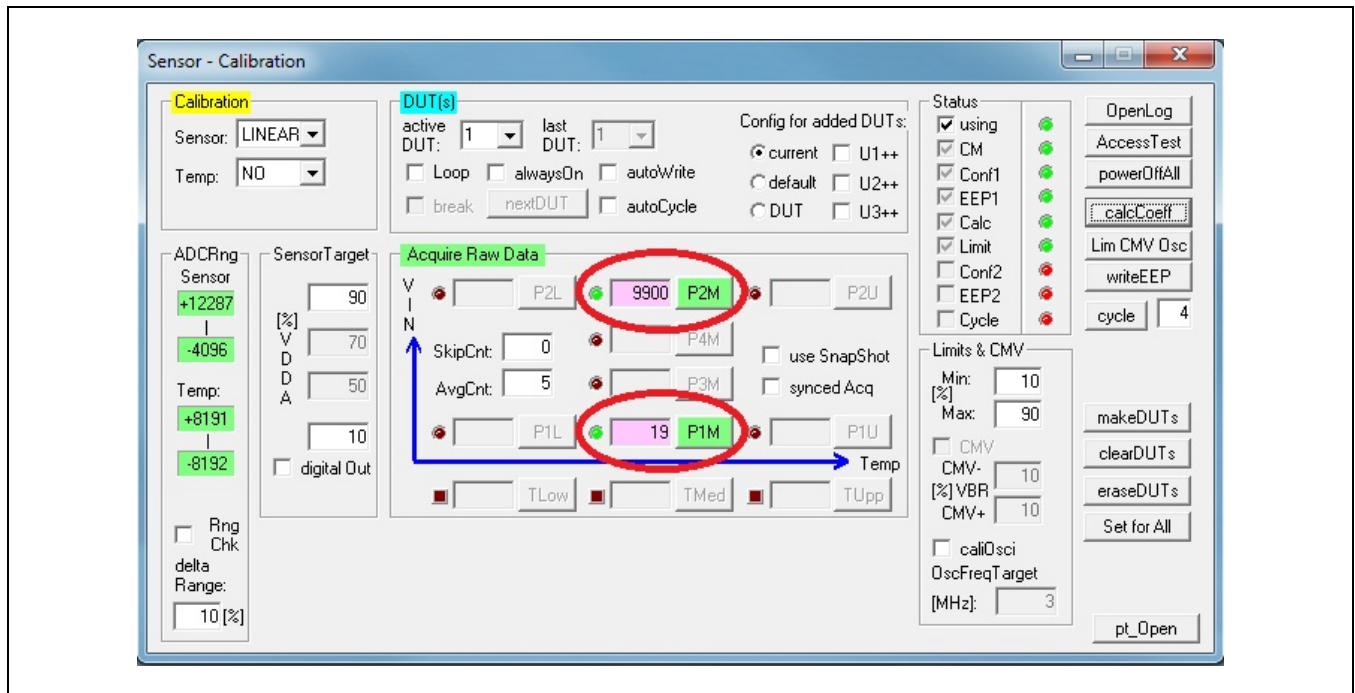

2.1. Threshold with Offset and Hysteresis

The threshold or the switching point is where the output voltage changes between the set maximum and minimum level (V_{MIN} and V_{MAX}); i.e., the switch is triggered.

To design a switch with the ZSSC3131 or ZSSC3136, first a normal calibration procedure should be performed. This will determine the raw data values (P1M and P2M as shown in Figure 2.1) corresponding to the minimum and maximum (V_{MIN} and V_{MAX}) output levels (see Figure 2.2).

Next the thresholds, including offset, can be calculated using the equations below:

Equations	Symbol Definitions
$p_2 = \frac{P2M - P1M}{100} * p_{Th}[\%] + P1M$	p_1, p_2 : Threshold levels. If p_2 is greater than p_1 (positive offset), then the output signal is active-HIGH and vice versa.
$p_1 = p_2 + /- \text{Offset}$	$P1M, P2M$: Acquired raw data from initial calibration.
$P1M < p_1 < p_2 \text{ or } P1M < p_2 < p_1$ (active-HIGH or active-LOW signal)	Offset: Number of steps between V_{MIN} and V_{MAX} corresponding to the raw data values.
$p_1 < p_2 < P2M \text{ or } p_2 < p_1 < P2M$ (active-HIGH or active-LOW signal)	$p_{Th} [\%]$: Desired switching level in percentage of the sensor signal range (0% - 100%).
$1 \leq \text{Offset} \leq (P2M - P1M)$	V_{MIN}, V_{MAX} : Minimum and maximum of analog output AOUT. V_{DD} : Supply voltage (Max. 5.5V). Active-HIGH/LOW: Depending on the sign used for the offset active-HIGH (-) or active LOW (+) output is defined.

Figure 2.2 Switch Implementation

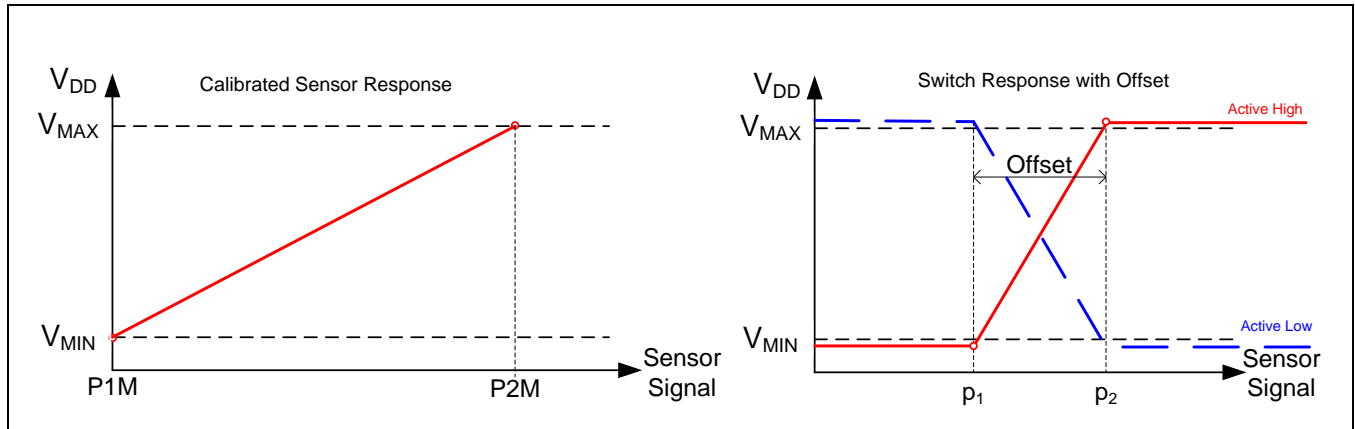

An actual hysteresis can be achieved using external components (for example a Schmitt trigger as shown in Figure 3.4). Trigger levels can be any levels within the V_{MIN} and V_{MAX} window (maximum is 5% to 95% of V_{DD}). In normal cases, these differ from V_{MIN} and V_{MAX} and p_1 and p_2 must be adjusted as described in section 2.2.

Figure 2.3 Switch with Hysteresis

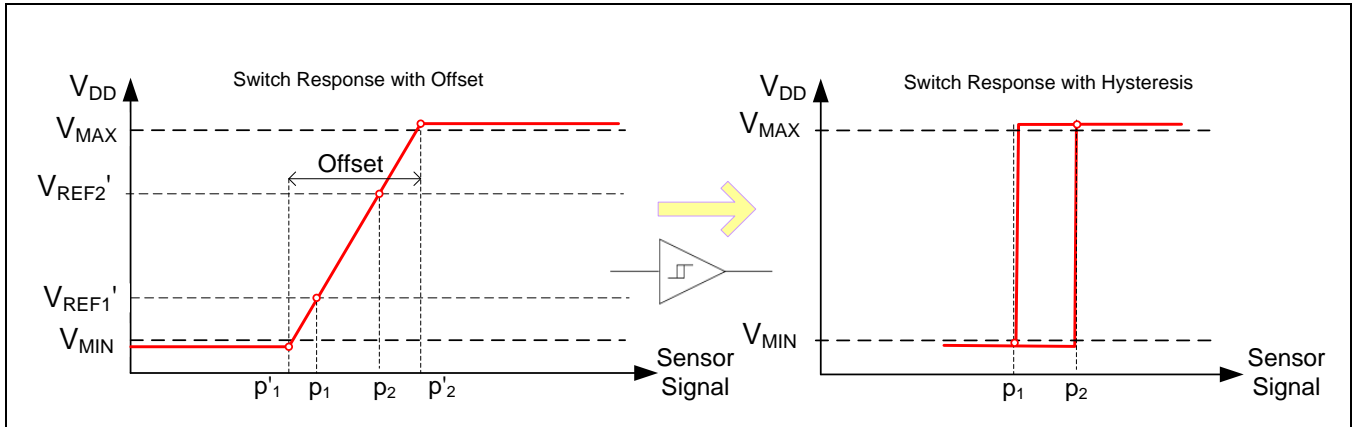

Note that the p_1 and p_2 parameters should not exceed the P1M and P2M values.

To complete the procedure for setting the switch threshold and offset, the P1M and P2M values must be replaced with the calculated p_1 and p_2 and **the coefficients must be calculated and stored again by clicking [calcCoef](#)**.

Example: Calibrating a pressure sensor using the ZSSC3131. Measured P1M = 100 (at 0 psi for 0%) and P2M = 8000 (at 10psi for 100%). The trigger level is chosen as 50% and hysteresis at 100, active-HIGH (-):

$$\text{Result} \rightarrow P2M = p_2 = \frac{8000 - 100}{100} * 50 + 100 = 4050 \quad P1M = p_1 = 4050 - 100 = 3950$$

Figure 2.4 Switch Setting Example

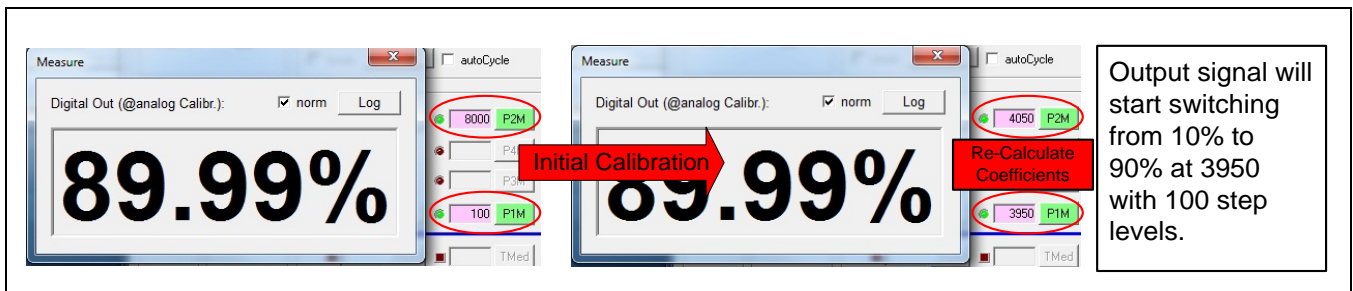

2.2. Alarm Window

In order to achieve an alarm window with a single analog voltage output, external components must be added as shown in the application circuits in section 3.

There are two external reference voltages (V_{REF1} and V_{REF2} corresponding to sensor outputs p_1 and p_2) setting the trigger points and shaping the alarm window. When the output voltage is within the desired limits, both comparator outputs are HIGH, so no current is running through the load R_L (see Figure 3.3).

Table 2.1 Alarm Window Operation using Two Comparators

Input	Inverting	Non-Inverting	Load
$V < V_{REF1}$	HIGH	LOW	On
$V_{REF1} < V < V_{REF2}$	HIGH	HIGH	Off
$V > V_{REF2}$	LOW	HIGH	On

If the alarm window is relatively narrow, it makes sense to adjust the calibration of the sensor so that the output response is within user-selected margins, for example $\pm\Delta p$, of the alarm window (see Figure 2.5). This will increase the voltage difference (ΔV) of the trigger points and will make the actual schematic implementation easier. However, the change in the trigger levels should be taken into account for the given switching points using the subsequent equations. Formulas for calibration values based on actual measured trigger levels are also given.

Figure 2.5 Sensor Range Correction

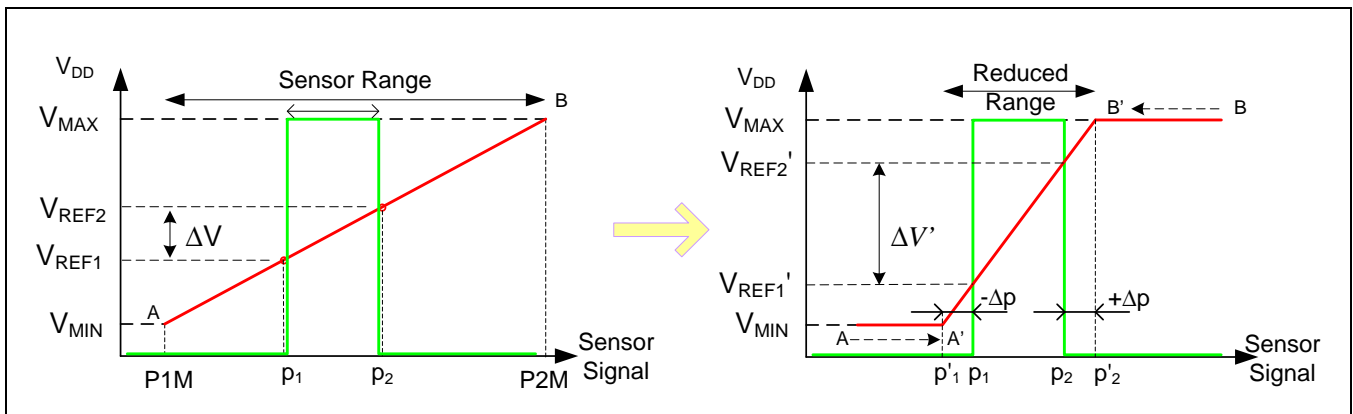

Subsequent calculations:	With given trigger levels V'_{REF1} and V'_{REF2} and defined window points $p_{1/2}$ [%] (reverse task):
$p_{1/2} = \frac{P2M - P1M}{100} p_{1/2}[\%] + P1M$ $V_{REFn} = (V_{MIN} + \frac{V_{MAX} - V_{MIN}}{100} p_n[\%]) \frac{V_{DD}}{100}$ $p'_1 = p_1 - \Delta p \quad p'_2 = p_2 + \Delta p$ $V'_{REF1} = \frac{\Delta p}{p'_2 - p'_1} (V_{MAX} - V_{MIN}) + V_{MIN}$ $V'_{REF2} = \frac{p_2 - p'_1}{p'_2 - p'_1} (V_{MAX} - V_{MIN}) + V_{MIN}$	$p_{1/2} = \frac{P2M - P1M}{100} p_{1/2}[\%] + P1M$ $p'_1 = \frac{p_1 k_2 - p_2 k_1}{k_2 - k_1}$ $p'_2 = p'_1 + \frac{p_2 - p'_1}{k_2} (V_{MAX} - V_{MIN})$ <p>Where</p> $k_1 = V'_{REF1} - V_{MIN} \quad k_2 = V'_{REF2} - V_{MIN}$

2.3. Digital Filter

The ZSSC3131 and ZSSC3136 offer a digital (averaging) filter function for calculating the output result. In practice, the digital filter adds the limitation of the analog output signal change (raise or fall).

Mathematically the function can be described with the following equations:

Equations	Symbol Definitions
$S_{OUTi} = S_{OUTi-1} + (S_i - S_{OUTi-1}) * \frac{LPF_{DIFF} + 1}{2^{LPF_{AVRG}}}; \quad i > 0;$ $S_{AVRG}, S_{DIFF} \in [0;7]$ $\frac{LPF_{DIF} + 1}{2^{LPF_{AVGR}}} \leq 1$	<p>S_i : Conditional equation result</p> <p>S_{OUTi} : Output result to be calculated</p> <p>LPF_{DIFF} : Low pass filter differential coefficient (differential)</p> <p>LPF_{AVG} : Averaging low pass filter coefficient (integrating)</p>

Note that the $\frac{LPF_{DIFF} + 1}{2^{LPF_{AVRG}}}$ coefficient must never become larger than 2! Otherwise, the filter function will oscillate and the system would have a flywheel effect.

The output S_{OUTi} is set to S_i for the first calculation of an output result.

The difference between this filter function and the function described in section 2.1 is that the output result is changing per measuring cycle (at specific time intervals). It is a purely software solution for noise immunity that adds a delay to the response even if the trigger point is reached.

Note that setting the coefficients LPF_{AVRG} and LPF_{DIFF} to 0 disables the filter function.

2.4. Fast or Slow Switches

Depending on the target applications, both fast and slow switches can be achieved using ZSSC3131/36 signal conditioners. An ON/OFF delay can be implemented externally by adding a delay section in the drive circuit based on passive components. Table 2.2 outlines the applicable configuration:

Table 2.2 Fast vs. Slow Switch Setup

Switch	Offset	Hysteresis	Digital Filter	Delay	Comments
Fast Switch	Yes/No	Yes	No	No	The switch will trigger once the threshold level is reached. External hysteresis can be used for noise immunity.
Slow Switch	Yes/No	Yes	Yes	Yes	All configuration parameters are applicable for shaping the output response.

3 Application Circuits

Figure 3.1 Sensor Switch Application Driving a Relay

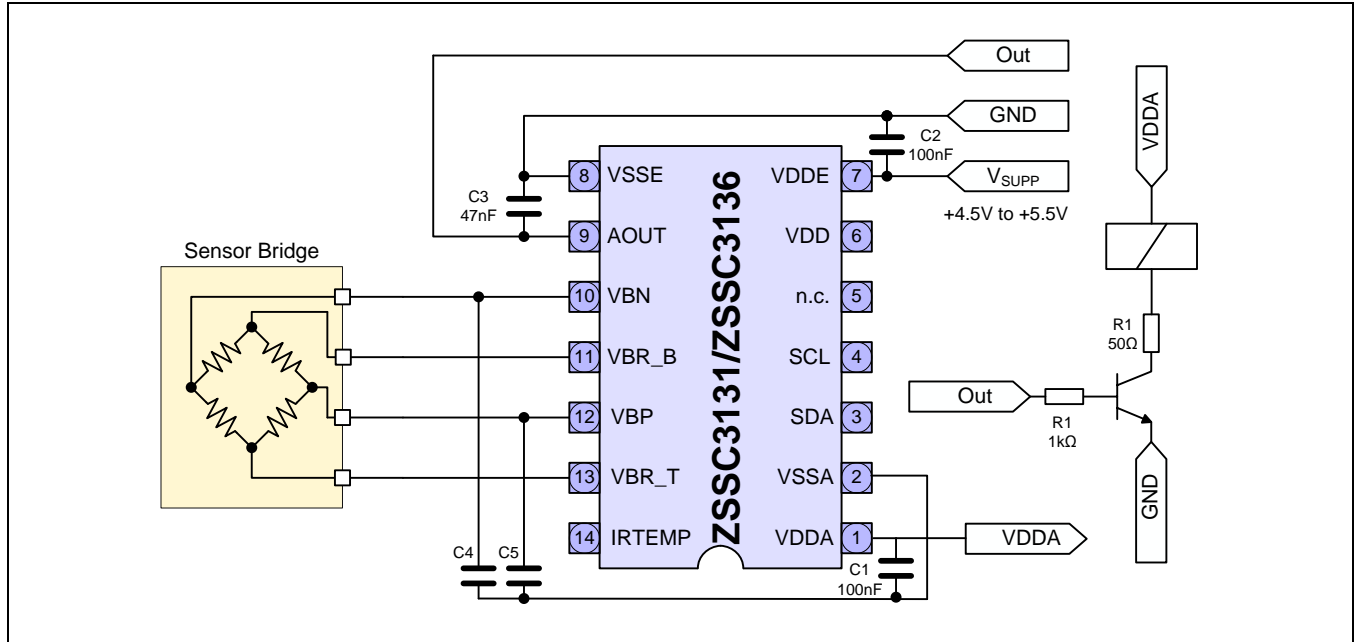
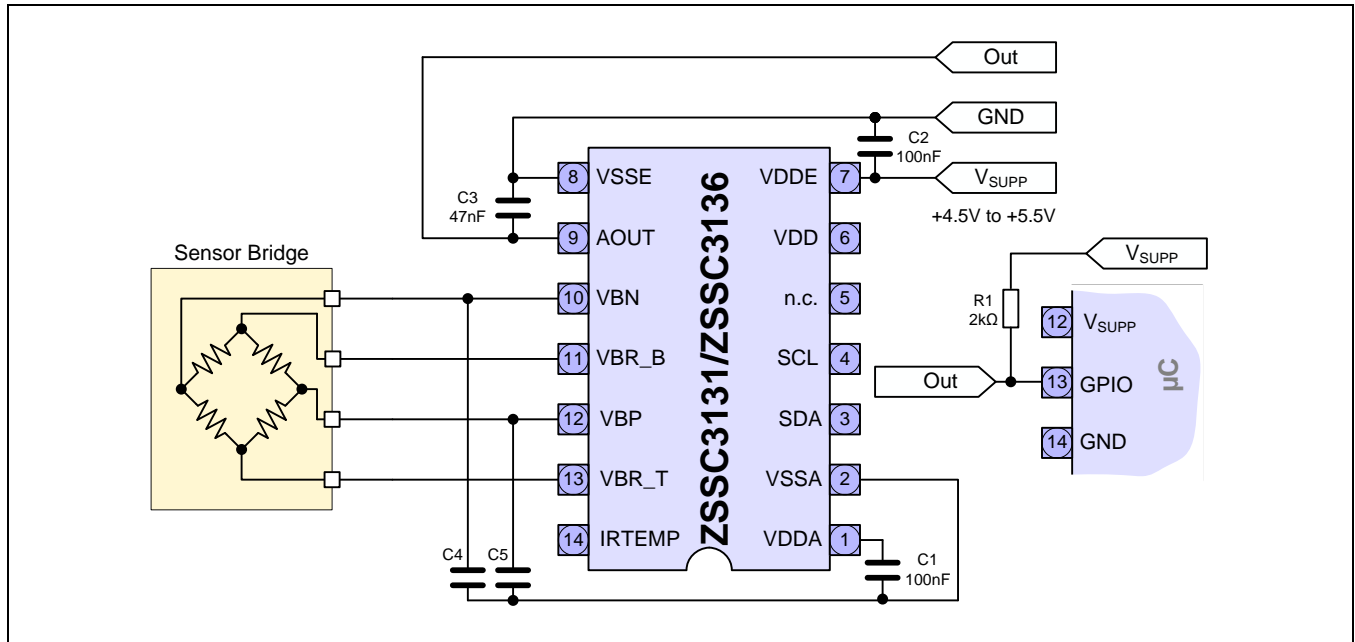

Figure 3.2 Sensor Switch Application Connected to a Microcontroller



4 Related Documents

Document
ZSSC313x Functional Description
ZSSC313x Evaluation Kit Description
ZSSC313x High Voltage Protection Description
ZSSC3131 Documents
ZSSC3131 Feature Sheet
ZSSC3131 Data Sheet
ZSSC 3136 Documents
ZSSC3136 Feature Sheet
ZSSC3136 Data Sheet

Visit IDT's website www.IDT.com or contact your nearest sales office for the latest version of these documents.

5 Glossary

Term	Description
AEC	Automotive Electronics Council
EEPROM	Electrically Erasable Programmable Read Only Memory
ESD	Electrostatic Device
SIL	Safety Integrity Level

6 Document Revision History

Revision	Date	Description
1.00	May 30, 2012	First release.
	March 30, 2016	Changed to IDT branding.

IMPORTANT NOTICE AND DISCLAIMER

RENESAS ELECTRONICS CORPORATION AND ITS SUBSIDIARIES (“RENESAS”) PROVIDES TECHNICAL SPECIFICATIONS AND RELIABILITY DATA (INCLUDING DATASHEETS), DESIGN RESOURCES (INCLUDING REFERENCE DESIGNS), APPLICATION OR OTHER DESIGN ADVICE, WEB TOOLS, SAFETY INFORMATION, AND OTHER RESOURCES “AS IS” AND WITH ALL FAULTS, AND DISCLAIMS ALL WARRANTIES, EXPRESS OR IMPLIED, INCLUDING, WITHOUT LIMITATION, ANY IMPLIED WARRANTIES OF MERCHANTABILITY, FITNESS FOR A PARTICULAR PURPOSE, OR NON-INFRINGEMENT OF THIRD-PARTY INTELLECTUAL PROPERTY RIGHTS.

These resources are intended for developers who are designing with Renesas products. You are solely responsible for (1) selecting the appropriate products for your application, (2) designing, validating, and testing your application, and (3) ensuring your application meets applicable standards, and any other safety, security, or other requirements. These resources are subject to change without notice. Renesas grants you permission to use these resources only to develop an application that uses Renesas products. Other reproduction or use of these resources is strictly prohibited. No license is granted to any other Renesas intellectual property or to any third-party intellectual property. Renesas disclaims responsibility for, and you will fully indemnify Renesas and its representatives against, any claims, damages, costs, losses, or liabilities arising from your use of these resources. Renesas' products are provided only subject to Renesas' Terms and Conditions of Sale or other applicable terms agreed to in writing. No use of any Renesas resources expands or otherwise alters any applicable warranties or warranty disclaimers for these products.

(Disclaimer Rev.1.01)

Corporate Headquarters

TOYOSU FORESIA, 3-2-24 Toyosu,
Koto-ku, Tokyo 135-0061, Japan
www.renesas.com

Trademarks

Renesas and the Renesas logo are trademarks of Renesas Electronics Corporation. All trademarks and registered trademarks are the property of their respective owners.

Contact Information

For further information on a product, technology, the most up-to-date version of a document, or your nearest sales office, please visit www.renesas.com/contact-us/.