

Renesas RA Family

Third-Party Program Protection for RA0 MCUs

Introduction

This application note provides information on how to protect the Third-Party Program (Software IP) contents for MCUs in the RA0 Family Group.

As used here, the term “third-party program” refers to valuable software IP supplied in formats such as libraries or binary format. The security functions of the RA0 devices can be employed to prevent unauthorized usage of such software IP.

Third-party program protection makes use of the following functions.

- Memory Protection (Flash Read Protection) – Implements memory protection functionality to prevent unauthorized access to the software IP program code stored in flash memory. Guidelines are provided on configuring and utilizing the memory protection feature of the RA0E1 MCU to safeguard software IP stored in flash memory.
- Startup Control with Unique ID – Enables a startup control mechanism that verifies an embedded ID in flash memory during software IP launch. Instructions are provided on the implementation of startup control to verify a Unique ID during program launch, ensuring authenticity and integrity.

Note: This Application Note applies to every MCU specified below in the Target Devices section. However, the ideas of this document are illustrated using the RA0E1 MCU as an example. If you are using a different device, refer to the relevant chapters of the MCU’s Hardware User’s Manual for specifics.

Target Devices

RA0E1

RA0E2

RA0E3

RA0L1

Contents

1. Overview	3
1.1 About This Application Note	3
1.2 Third-Party Program (Software IP) Protection Requirement	3
1.3 Possible Protection Countermeasures	3
2. Security Functions of the RA0E1	3
2.1 Memory Protection (Flash Read Protection)	3
2.2 Startup Control (Link to Unique ID)	4
3. Use Cases for Third-Party Program (Software IP) Protection	5
3.1 Third-Party Program Protection	5
3.2 User Application Protection	6
4. Memory Protection Setting Methods	7
4.1 Setting the Option-Setting Memory	8
4.1.1 Allocation of Data in Option-Setting Memory	8
4.1.2 Setting Data for Programming the Option-Setting Memory	9
5. Related Application Notes	9
6. Next Steps	10
7. Reference Documents	10
Revision History	12

1. Overview

1.1 About This Application Note

This application note describes the third-party program (software IP) protection that can be implemented using the security functions of the RA0E1.

1.2 Third-Party Program (Software IP) Protection Requirement

Software IP is subject to issues such as the following:

- When software IP is supplied in binary format, it can be duplicated, and multiple copies can be used by unauthorized users.
- When the software IP has been programmed to an MCU supplied as a finished product, it can be read from the flash memory, analyzed, and re-used in unauthorized products.

1.3 Possible Protection Countermeasures

Two examples of countermeasures that can be implemented on the RA0E1 to protect software IP are described below.

- Memory Protection (Flash Read Protection)
This approach implements memory protection functionality to prevent unauthorized access to the software IP program code stored in flash memory. This protection involves defining specific regions of the code flash as read-prohibited, enhancing the security of the IP.
Refer to [Section 2.1, Memory Protection \(Flash Read Protection\)](#), for more information.
- Startup Control
This approach checks an ID programmed in the flash memory when the software IP is launched. This approach is suitable for cases where the developer supplies the software IP in binary format.
Refer to [Section 2.2 Startup Control \(Link to Unique ID\)](#) for more information.

2. Security Functions of the RA0E1

The RA0E1 is provided with the security functions listed below. These functions can be used individually or in combination to protect the software IP from unauthorized use.

- Memory Protection (Flash Read Protection)
- Startup Control (Link to Unique ID)

2.1 Memory Protection (Flash Read Protection)

Flash read protection is a function that prevents specified areas of the flash code from being read by the CPU, DTC, and Debugger. This function can be used to prohibit the reading of software IP programmed in the code flash memory. Areas that are set to read-prohibited status can only be accessed with instruction fetches by the MCU. Note that programs running from a read-prohibited area cannot themselves read the read-prohibited data. Therefore, it is necessary that all data used by a program run from a read-prohibited area, which must be located in an area that is not protected.

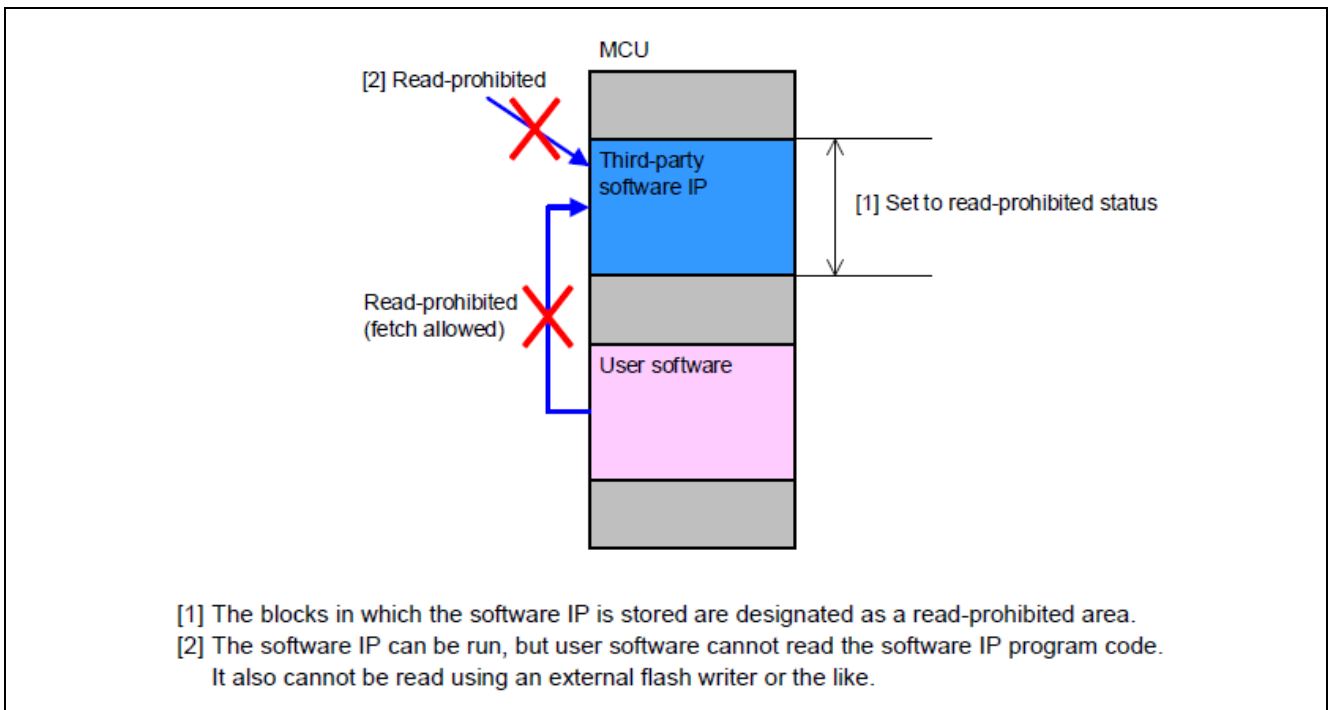

Figure 1 Flash Read Protection

Features: Prevents analysis or copying of the software IP set to read-prohibited status. To prevent unauthorized use or re-use of the software IP by the recipient, it is necessary to supply CPUs with the software IP pre-programmed in a read-prohibited area of the flash memory.

For information on how to set a memory area to read-prohibited status, refer to [Memory Protection Settings Methods](#).

2.2 Startup Control (Link to Unique ID)

The Unique ID is a value specific to the individual device that is stored in flash memory at the time the MCU is manufactured.

By registering Unique IDs within a software program, it is possible to limit individuals (MCUs) authorized to run it.

In cases where the software license is dependent on the number of copies of the product, it is possible to maintain a list of licensed Unique IDs within the software, thereby ensuring that it can only be run on products with licensed Unique IDs.

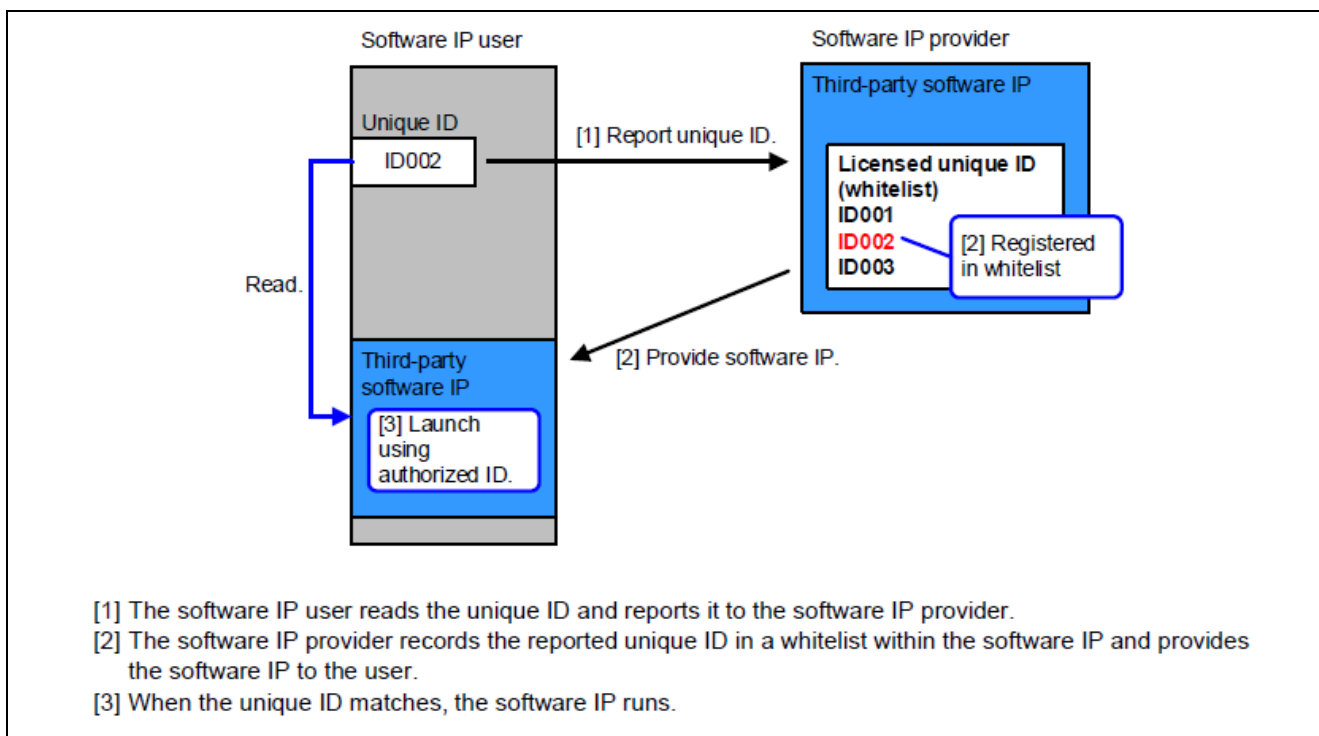

Figure 2 Startup Control (Link to Unique ID)

Features: Prevents unauthorized use in cases where it is not possible to prohibit copying of software IP. If the software IP is copied to another MCU with a different and unauthorized Unique ID, it will not run.

The 128-bit Unique ID can be read directly with the FSP API **R_BSP_UniqueIdGet()**.

```
typedef struct st_bsp_unique_id
{
    union
    {
        uint32_t unique_id_words[4];
        uint8_t unique_id_bytes[16];
    };
} bsp_unique_id_t;

uint32_t mcu_id[4];
volatile const bsp_unique_id_t* unique_id = R_BSP_UniqueIdGet();
mcu_id[0] = unique_id->unique_id_words[0];
mcu_id[1] = unique_id->unique_id_words[1];
mcu_id[2] = unique_id->unique_id_words[2];
mcu_id[3] = unique_id->unique_id_words[3];
```

For more information on **R_BSP_UniqueIdGet()**, refer to FSP User's Manual (R11UM0155).

3. Use Cases for Third-Party Program (Software IP) Protection

Unique ID is used as an example to demonstrate a use case for third-party program (software IP) protection. A second example is shown where access protection can be used to protect user application programs as well as third-party programs (software IP).

3.1 Third-Party Program Protection

Protects third-party software IP in cases where a third party undertakes the entire software development.

Prevents unauthorized use of software IP by general users and set makers.

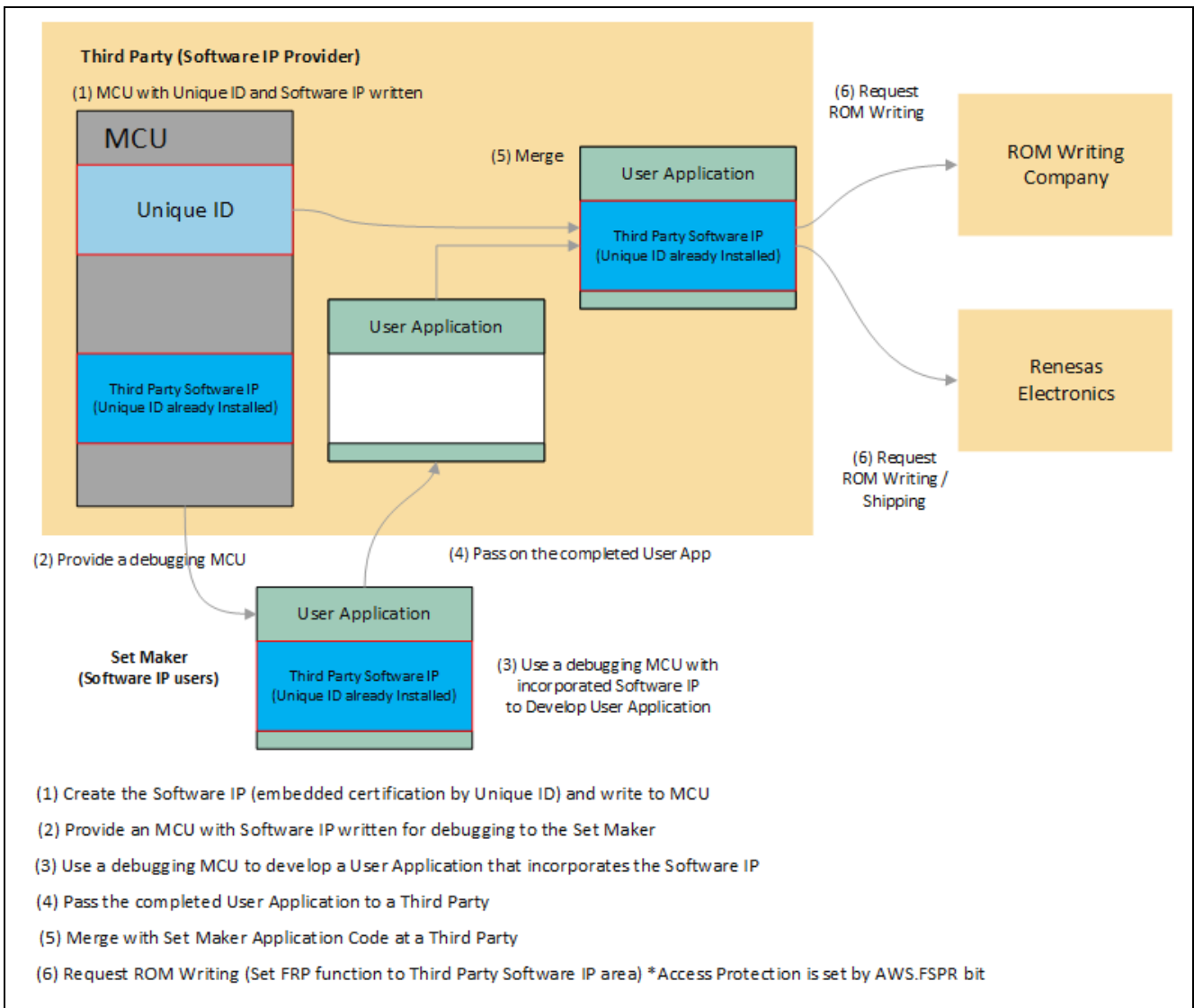

Figure 3 Third Party Program Protection

3.2 User Application Protection

In the case where software IP is provided by a third party and software is developed by a set maker, the third-party software IP and the user application of the set maker are protected.

Prevents unauthorized use of third-party software IP and user application by end users.

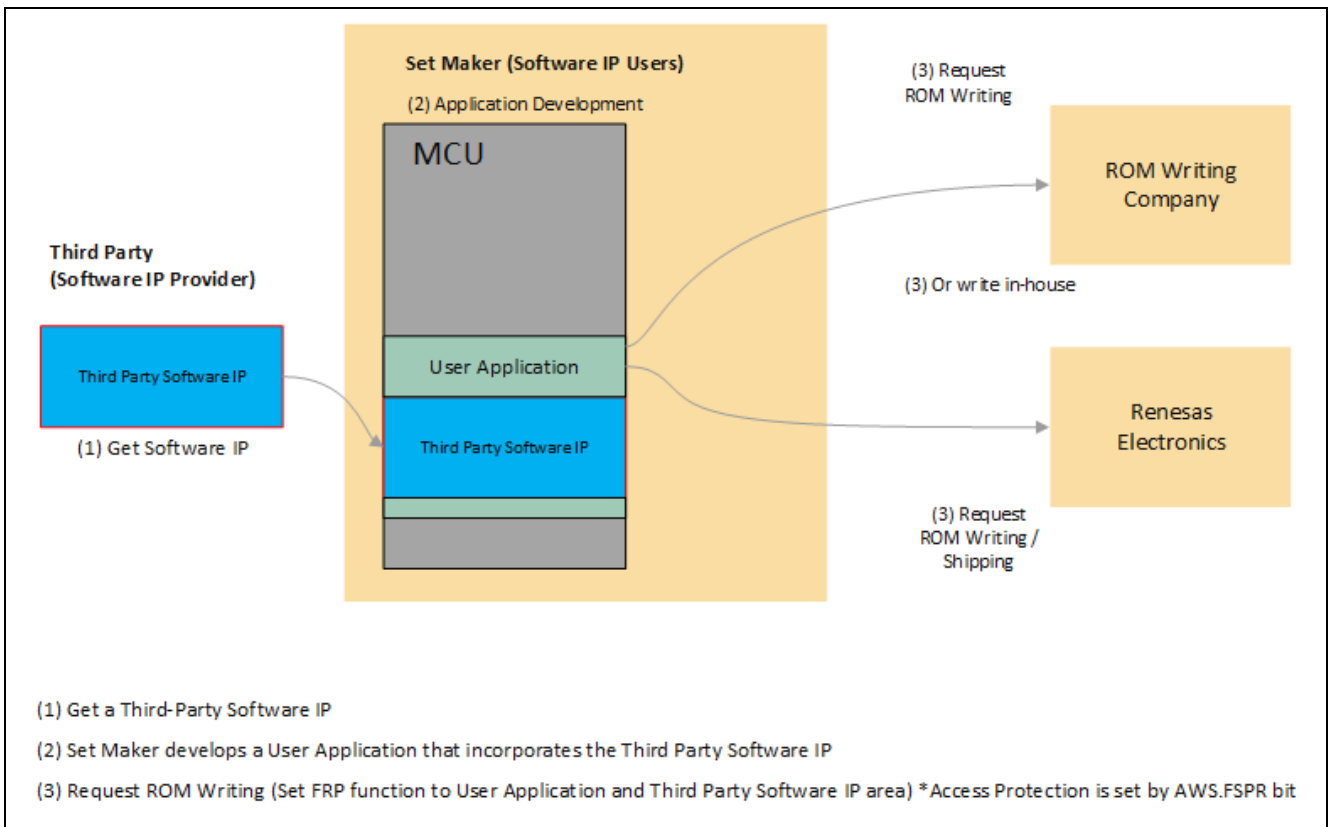

Figure 4 User Application Protection

4. Memory Protection Setting Methods

To set up Memory Protection on the RA0E1, it is important to understand the system architecture, which includes three mechanisms that provide access protection to the user application and software IP. The functions are Flash Read Protection (FRP), Access Window Setting (AWS), and ID Code Protection.

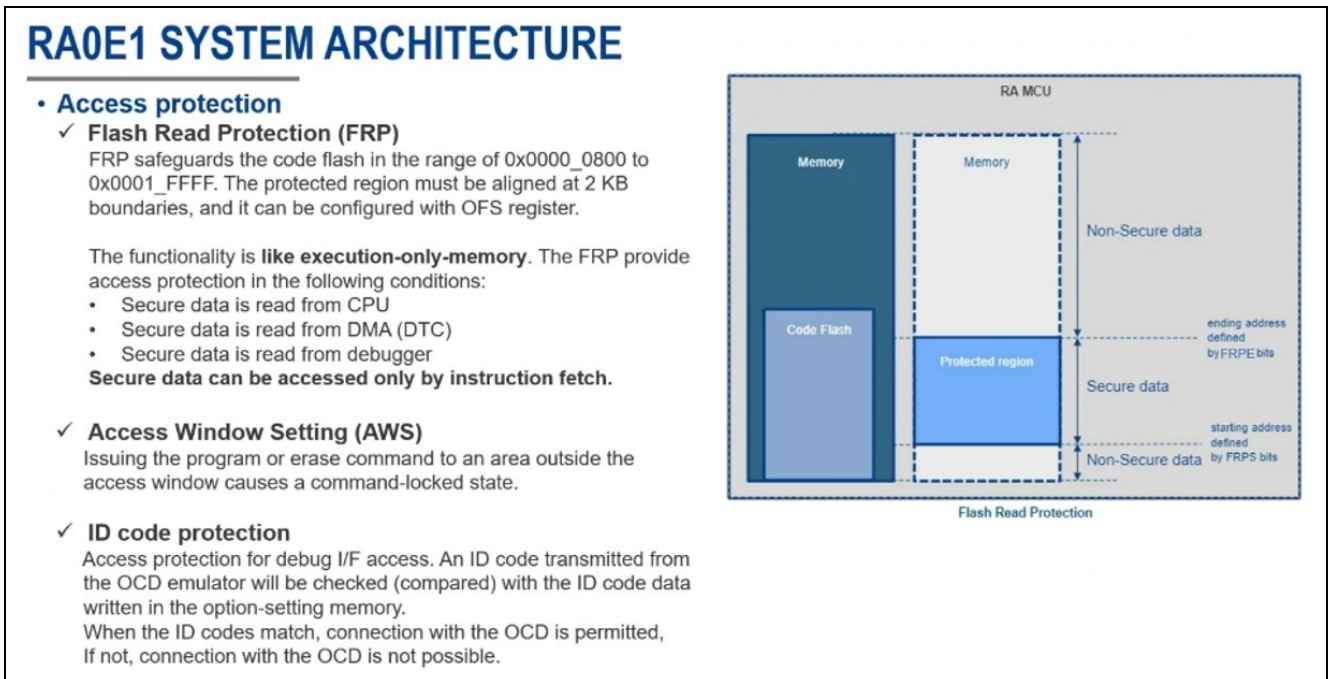

Figure 5 RA0E1 Access Protection

User application self-programming and debuggers use flash read/erase methods that must be considered in determining the required level of access protection for the user application and software IP. In the RA0E1, the Option-setting memory is allocated to the Configuration area access and the Program flash area, which are used to set up the access protection. Under certain conditions, the Configuration area can be reprogrammed by self-programming or a debugger. In this case, the Flash Read Protection can be disabled.

To provide the best level of access protection, use the Access Window Protection Flag FSPR=0, where the AWS.FSPR bit can be used to lock the AWS configuration permanently. When locked, the AWS register cannot be rewritten by any method, such as a flash programmer, debugger, or user application self-programming. With this feature, the Flash Read Protection is permanent.

Note: The AWS.FSPR bit cannot be changed to 1 once it is set to 0. At that time, the access window and startup area selection cannot be set again.

Issuing the program or erasing a command to an area outside the access window causes a command-locked state. The access window is only valid in the program flash area. The access window provides protection in self-programming mode, and on-chip debug mode.

With ID Code Protection, debug interface access is handled by an ID code transmitted from the OCD emulator that is compared to the ID code data written in the Option-Setting Memory. Connection with the OCD is only permitted when the ID code matches. Note with ID Code Protection, only the OSIS register can be re-written by self-programming.

For more information on Flash Read Protection, AWS, and ID Code Protection, refer to RA0E1 User's Manual (R01UH1040) **Section 6 Option-Setting Memory**.

Memory Protection is enabled by setting the Option-Setting Memory. Refer to [Figure 6 RA0E1 Option-Setting Memory Area](#) below for the RA0E1 Option-Setting Memory Area register map and the RA0E1 User's Manual (R01UH1040) **Section 6.2 Register Descriptions** for more details on the OSIS, AWS, and Option Function Select (OFS) Registers.

The Option-Setting Memory determines the state of the MCU after a reset. The Option-Setting Memory is divided into the **Configuration setting area** and the **Program flash area** of the flash memory. The available methods of setting are different for each of the two areas.

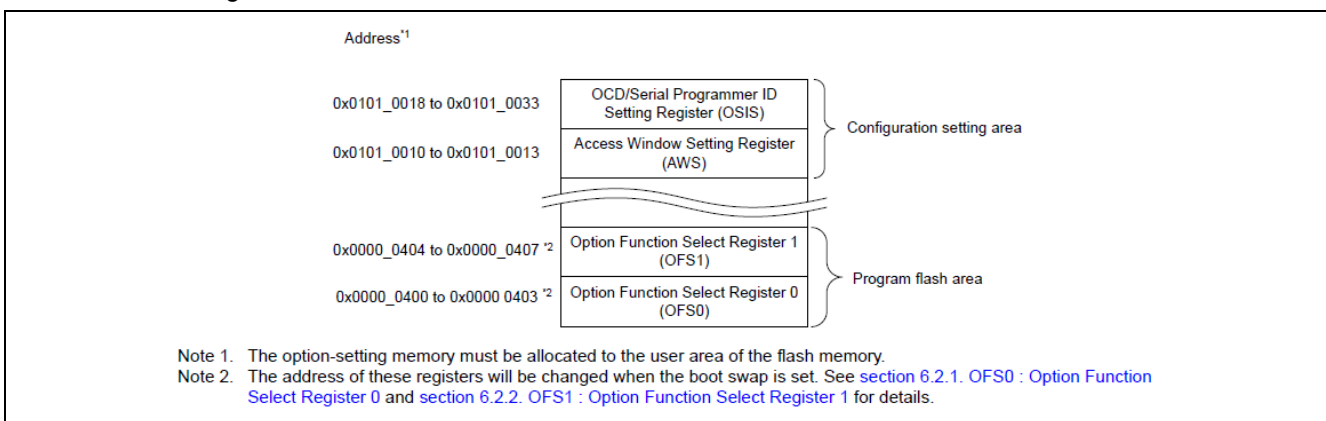

Figure 6 RA0E1 Option-Setting Memory Area

4.1 Setting the Option-Setting Memory

4.1.1 Allocation of Data in Option-Setting Memory

Programming data is allocated to the addresses in the option-setting memory, as shown in [Figure 6 RA0E1 Option-Setting Memory Area](#). The option-setting memory must be allocated to the user area of the flash memory. The allocated data is used by tools such as flash programming software or an on-chip debugger.

Note: The programming formats vary depending on the compiler used. See the compiler manual for more details.

4.1.2 Setting Data for Programming the Option-Setting Memory

Allocating data according to the procedure described in [Section 4.1.1 Allocation of Data in Option-Setting Memory](#) alone does not write the data to the option-setting memory. You must follow one of the actions described below in this section.

1. Changing the Option-Setting Memory by Self-Programming

Use the programming command to write data to the program flash area. Next, use the configuration setting command to write data to the option-setting memory in the configuration setting area for the OSIS and Access Window Setting Registers. In addition, use the startup area select function to safely update the boot program, which includes the option-setting memory. For more details on the programming command, the configuration setting command, and the startup area select function, see **Section 28 Flash Memory** of the RA0E1 User's Manual (R01UH1040).

2. Debugging through an OCD or Programming by a Flash Writer

This procedure depends on the tool or utility in use. See the tool manual for more details.

In general, the MCU provides two setting procedures:

- Read the data allocated as described in [Section 4.1.1 Allocation of Data in Option-Setting Memory](#) from an object file or Motorola S-format file generated by the compiler and write the data to the MCU.
- Use the GUI interface of the tool to program the MCU with the same data in [Section 4.1.1 Allocation of Data in Option-Setting Memory](#).

Note: If you are using the e² studio IDE, the OFS settings are configured in e² studio and are set by writing the object after compilation.

Refer to the RA0E1 User's Manual (R01UH1040) **Section 6.3 Setting Option-Setting Memory** for more information and usage notes.

5. Related Application Notes

Application notes related to this application note are listed below.

1. FPB-RA0E1 Example Project Bundle (R20AN0745)
2. FPB-RA0E1 Tutorial (R01AN7315)
3. RA0 Quick Design Guide (R01AN7309)

6. Next Steps

Visit renesas.com/ra/fpb-ra0e1 for more information about the FPB-RA0E1 example kit, including its Quick Start Guide, design data, ordering information, and other useful application projects.

7. Reference Documents

RA0E1 Group FPB-RA0E1 User's Manual (R20UT5378) [FPB-RA0E1 – User's Manual](#)

RA0E1 Group User's Manual: Hardware (R01UH1040) [RA0E1 Hardware User's Manual](#)

RA0E2 Group User's Manual: Hardware (R01UH1090) [RA0E2 Hardware User's Manual](#)

RA0E3 Group User's Manual: Hardware (R01UH1165) [RA0E3 Hardware User's Manual](#)

RA0L1 Group User's Manual: Hardware (R01UH1143) [RA0L1 Hardware User's Manual](#)

Flexible Software Package (FSP) User's Manual: (R11UM0155) [RA Flexible Software Package \(FSP\)](#)

Website and Support

Visit the following vanity URLs to learn about key elements of the RA family, download components and related documentation, and get support.

RA Product Information	www.renesas.com/ra
RA Product Support Forum	www.renesas.com/ra/forum
RA Flexible Software Package	www.renesas.com/FSP
Renesas Support	www.renesas.com/support

Revision History

Rev.	Date	Description	
		Page	Summary
1.00	Jul.31.24	—	First release document
1.10	Apr.21.25	—	Added RA0E2
1.20	Mar.03.26	1, 10	Added RA0L1, RA0E3

General Precautions in the Handling of Microprocessing Unit and Microcontroller Unit Products

The following usage notes are applicable to all Microprocessing unit and Microcontroller unit products from Renesas. For detailed usage notes on the products covered by this document, refer to the relevant sections of the document as well as any technical updates that have been issued for the products.

- 1. Precaution against Electrostatic Discharge (ESD)**

A strong electrical field, when exposed to a CMOS device, can cause destruction of the gate oxide and ultimately degrade the device operation. Steps must be taken to stop the generation of static electricity as much as possible, and quickly dissipate it when it occurs. Environmental control must be adequate. When it is dry, a humidifier should be used. This is recommended to avoid using insulators that can easily build up static electricity. Semiconductor devices must be stored and transported in an anti-static container, static shielding bag or conductive material. All test and measurement tools including work benches and floors must be grounded. The operator must also be grounded using a wrist strap. Semiconductor devices must not be touched with bare hands. Similar precautions must be taken for printed circuit boards with mounted semiconductor devices.
- 2. Processing at power-on**

The state of the product is undefined at the time when power is supplied. The states of internal circuits in the LSI are indeterminate and the states of register settings and pins are undefined at the time when power is supplied. In a finished product where the reset signal is applied to the external reset pin, the states of pins are not guaranteed from the time when power is supplied until the reset process is completed. In a similar way, the states of pins in a product that is reset by an on-chip power-on reset function are not guaranteed from the time when power is supplied until the power reaches the level at which resetting is specified.
- 3. Input of signal during power-off state**

Do not input signals or an I/O pull-up power supply while the device is powered off. The current injection that results from input of such a signal or I/O pull-up power supply may cause malfunction and the abnormal current that passes in the device at this time may cause degradation of internal elements. Follow the guideline for input signal during power-off state as described in your product documentation.
- 4. Handling of unused pins**

Handle unused pins in accordance with the directions given under handling of unused pins in the manual. The input pins of CMOS products are generally in the high-impedance state. In operation with an unused pin in the open-circuit state, extra electromagnetic noise is induced in the vicinity of the LSI, an associated shoot-through current flows internally, and malfunctions occur due to the false recognition of the pin state as an input signal become possible.
- 5. Clock signals**

After applying a reset, only release the reset line after the operating clock signal becomes stable. When switching the clock signal during program execution, wait until the target clock signal is stabilized. When the clock signal is generated with an external resonator or from an external oscillator during a reset, ensure that the reset line is only released after full stabilization of the clock signal. Additionally, when switching to a clock signal produced with an external resonator or by an external oscillator while program execution is in progress, wait until the target clock signal is stable.
- 6. Voltage application waveform at input pin**

Waveform distortion due to input noise or a reflected wave may cause malfunction. If the input of the CMOS device stays in the area between V_{IL} (Max.) and V_{IH} (Min.) due to noise, for example, the device may malfunction. Take care to prevent chattering noise from entering the device when the input level is fixed, and also in the transition period when the input level passes through the area between V_{IL} (Max.) and V_{IH} (Min.).
- 7. Prohibition of access to reserved addresses**

Access to reserved addresses is prohibited. The reserved addresses are provided for possible future expansion of functions. Do not access these addresses as the correct operation of the LSI is not guaranteed.
- 8. Differences between products**

Before changing from one product to another, for example to a product with a different part number, confirm that the change will not lead to problems. The characteristics of a microprocessing unit or microcontroller unit products in the same group but having a different part number might differ in terms of internal memory capacity, layout pattern, and other factors, which can affect the ranges of electrical characteristics, such as characteristic values, operating margins, immunity to noise, and amount of radiated noise. When changing to a product with a different part number, implement a system-evaluation test for the given product.

Notice

1. Descriptions of circuits, software and other related information in this document are provided only to illustrate the operation of semiconductor products and application examples. You are fully responsible for the incorporation or any other use of the circuits, software, and information in the design of your product or system. Renesas Electronics disclaims any and all liability for any losses and damages incurred by you or third parties arising from the use of these circuits, software, or information.
2. Renesas Electronics hereby expressly disclaims any warranties against and liability for infringement or any other claims involving patents, copyrights, or other intellectual property rights of third parties, by or arising from the use of Renesas Electronics products or technical information described in this document, including but not limited to, the product data, drawings, charts, programs, algorithms, and application examples.
3. No license, express, implied or otherwise, is granted hereby under any patents, copyrights or other intellectual property rights of Renesas Electronics or others.
4. You shall be responsible for determining what licenses are required from any third parties, and obtaining such licenses for the lawful import, export, manufacture, sales, utilization, distribution or other disposal of any products incorporating Renesas Electronics products, if required.
5. You shall not alter, modify, copy, or reverse engineer any Renesas Electronics product, whether in whole or in part. Renesas Electronics disclaims any and all liability for any losses or damages incurred by you or third parties arising from such alteration, modification, copying or reverse engineering.
6. Renesas Electronics products are classified according to the following two quality grades: "Standard" and "High Quality". The intended applications for each Renesas Electronics product depends on the product's quality grade, as indicated below.
 - "Standard": Computers; office equipment; communications equipment; test and measurement equipment; audio and visual equipment; home electronic appliances; machine tools; personal electronic equipment; industrial robots; etc.
 - "High Quality": Transportation equipment (automobiles, trains, ships, etc.); traffic control (traffic lights); large-scale communication equipment; key financial terminal systems; safety control equipment; etc.Unless expressly designated as a high reliability product or a product for harsh environments in a Renesas Electronics data sheet or other Renesas Electronics document, Renesas Electronics products are not intended or authorized for use in products or systems that may pose a direct threat to human life or bodily injury (artificial life support devices or systems; surgical implantations; etc.), or may cause serious property damage (space system; undersea repeaters; nuclear power control systems; aircraft control systems; key plant systems; military equipment; etc.). Renesas Electronics disclaims any and all liability for any damages or losses incurred by you or any third parties arising from the use of any Renesas Electronics product that is inconsistent with any Renesas Electronics data sheet, user's manual or other Renesas Electronics document.
7. No semiconductor product is absolutely secure. Notwithstanding any security measures or features that may be implemented in Renesas Electronics hardware or software products, Renesas Electronics shall have absolutely no liability arising out of any vulnerability or security breach, including but not limited to any unauthorized access to or use of a Renesas Electronics product or a system that uses a Renesas Electronics product. RENESAS ELECTRONICS DOES NOT WARRANT OR GUARANTEE THAT RENESAS ELECTRONICS PRODUCTS, OR ANY SYSTEMS CREATED USING RENESAS ELECTRONICS PRODUCTS WILL BE INVULNERABLE OR FREE FROM CORRUPTION, ATTACK, VIRUSES, INTERFERENCE, HACKING, DATA LOSS OR THEFT, OR OTHER SECURITY INTRUSION ("Vulnerability Issues"). RENESAS ELECTRONICS DISCLAIMS ANY AND ALL RESPONSIBILITY OR LIABILITY ARISING FROM OR RELATED TO ANY VULNERABILITY ISSUES. FURTHERMORE, TO THE EXTENT PERMITTED BY APPLICABLE LAW, RENESAS ELECTRONICS DISCLAIMS ANY AND ALL WARRANTIES, EXPRESS OR IMPLIED, WITH RESPECT TO THIS DOCUMENT AND ANY RELATED OR ACCOMPANYING SOFTWARE OR HARDWARE, INCLUDING BUT NOT LIMITED TO THE IMPLIED WARRANTIES OF MERCHANTABILITY, OR FITNESS FOR A PARTICULAR PURPOSE.
8. When using Renesas Electronics products, refer to the latest product information (data sheets, user's manuals, application notes, "General Notes for Handling and Using Semiconductor Devices" in the reliability handbook, etc.), and ensure that usage conditions are within the ranges specified by Renesas Electronics with respect to maximum ratings, operating power supply voltage range, heat dissipation characteristics, installation, etc. Renesas Electronics disclaims any and all liability for any malfunctions, failure or accident arising out of the use of Renesas Electronics products outside of such specified ranges.
9. Although Renesas Electronics endeavors to improve the quality and reliability of Renesas Electronics products, semiconductor products have specific characteristics, such as the occurrence of failure at a certain rate and malfunctions under certain use conditions. Unless designated as a high reliability product or a product for harsh environments in a Renesas Electronics data sheet or other Renesas Electronics document, Renesas Electronics products are not subject to radiation resistance design. You are responsible for implementing safety measures to guard against the possibility of bodily injury, injury or damage caused by fire, and/or danger to the public in the event of a failure or malfunction of Renesas Electronics products, such as safety design for hardware and software, including but not limited to redundancy, fire control and malfunction prevention, appropriate treatment for aging degradation or any other appropriate measures. Because the evaluation of microcomputer software alone is very difficult and impractical, you are responsible for evaluating the safety of the final products or systems manufactured by you.
10. Please contact a Renesas Electronics sales office for details as to environmental matters such as the environmental compatibility of each Renesas Electronics product. You are responsible for carefully and sufficiently investigating applicable laws and regulations that regulate the inclusion or use of controlled substances, including without limitation, the EU RoHS Directive, and using Renesas Electronics products in compliance with all these applicable laws and regulations. Renesas Electronics disclaims any and all liability for damages or losses occurring as a result of your noncompliance with applicable laws and regulations.
11. Renesas Electronics products and technologies shall not be used for or incorporated into any products or systems whose manufacture, use, or sale is prohibited under any applicable domestic or foreign laws or regulations. You shall comply with any applicable export control laws and regulations promulgated and administered by the governments of any countries asserting jurisdiction over the parties or transactions.
12. It is the responsibility of the buyer or distributor of Renesas Electronics products, or any other party who distributes, disposes of, or otherwise sells or transfers the product to a third party, to notify such third party in advance of the contents and conditions set forth in this document.
13. This document shall not be reprinted, reproduced or duplicated in any form, in whole or in part, without prior written consent of Renesas Electronics.
14. Please contact a Renesas Electronics sales office if you have any questions regarding the information contained in this document or Renesas Electronics products.

(Note1) "Renesas Electronics" as used in this document means Renesas Electronics Corporation and also includes its directly or indirectly controlled subsidiaries.

(Note2) "Renesas Electronics product(s)" means any product developed or manufactured by or for Renesas Electronics.

(Rev.5.0-1 October 2020)

Corporate Headquarters

TOYOSU FORESIA, 3-2-24 Toyosu,
Koto-ku, Tokyo 135-0061, Japan

www.renesas.com

Trademarks

Renesas and the Renesas logo are trademarks of Renesas Electronics Corporation. All trademarks and registered trademarks are the property of their respective owners.

Contact information

For further information on a product, technology, the most up-to-date version of a document, or your nearest sales office, please visit:

www.renesas.com/contact/.