

# Application note

## DA9053's High Efficiency Autonomous Charger

AN-PM-006

### Abstract

*The DA9053 Battery Charger offers fully automatic operation, as it is able to work without any external intervention from the Host processor. The charging parameters can be set in OTP to meet the requirements of most handheld system applications. The purpose of this paper is to offer a deep insight into common application cases, thus helping the designer in the process of choosing the right settings.*

---

---

DA9053's High Efficiency Autonomous Charger

Contents

**Abstract** ..... 1

**Contents** ..... 2

**Figures**..... 2

**Tables** ..... 2

**1 Introduction**..... 3

**2 External components**..... 4

**3 Choosing the right charger parameters**..... 5

    3.1 Pre-charge phase..... 5

    3.2 Constant current (CC) fast-charge phase ..... 6

    3.3 Constant Voltage (CV) phase ..... 7

    3.4 Connection and operation with DCIN / USB supplies ..... 9

    3.5 CHG\_USB\_ILIM setting and use of D+ / D-..... 17

    3.6 CHG\_TEMP ..... 18

    3.7 Battery temperature qualification ..... 19

**4 Summary and conclusion**..... 20

**Revision history**..... 21

Figures

Figure 1: Charger block diagram ..... 3

Figure 2: External components required for correct operation ..... 4

Figure 3: Li-Ion battery charge profile ..... 5

Figure 4: Cycle performance at various charge/discharge rates..... 6

Figure 5: Charge stages of a 4.2V Li-Ion Battery ..... 8

Figure 6: Connections of DA9053 battery charger ..... 9

Figure 7: Typical efficiency of DA9053's charger buck ..... 10

Figure 8: Profiles of charger current and voltage ..... 11

Figure 9: ISET\_BUCK value is higher than (Application + Charging) current..... 12

Figure 10: Current path from valid USB according to state B. .... 13

Figure 11: Current path from valid USB according to state C. .... 14

Figure 12: Power path, charger and system load measurements. .... 15

Figure 13: On-resistance of internal and external active diode. .... 16

Figure 14: Current path from valid USB according to state C and external active diode..... 16

Figure 15: USB Charger detection ..... 17

Tables

Table 1: Charging input device types ..... 9

Table 2: 3-way switch states ..... 12

Table 3: Thermal charge current control ..... 19

## DA9053's High Efficiency Autonomous Charger

### 1 Introduction

With reference to [Figure 1](#), the main building blocks of the charger are:

- External P-channel MOSFETs at VBUS and DCIN. These provide protection for the internal circuitry. VBUS\_PROT and DCIN\_PROT pins support charging at nominally 5V voltage, protected up to 5.6V. The sensing inputs VBUS and DCIN can withstand a voltage up to 12V. Higher input voltages will damage the charger. Internal logic, acting on the gate pins VBUS\_SEL and DCIN\_SEL, enables and disables the external switches.
- Two internal switches manage the power routing into the VCENTER node - the real input of the charger buck.
- The charger buck converter transfers input power to VDDOUT with high efficiency. The output voltage is regulated to be VBAT + 250 mV with a minimum of 3.6V, thus optimizing the efficiency of the following linear stage.
- A linear charging stage with an active diode allows the current to flow through a low on-resistance path in both directions, between the main application rail VDDOUT and the battery rail VBAT.
- The internal rail VDDREF is supplied either from VCENTER or VDDOUT, depending on which is the higher voltage, ensuring the highest voltage of the system is always available for the internal core activities, RTC and so on.

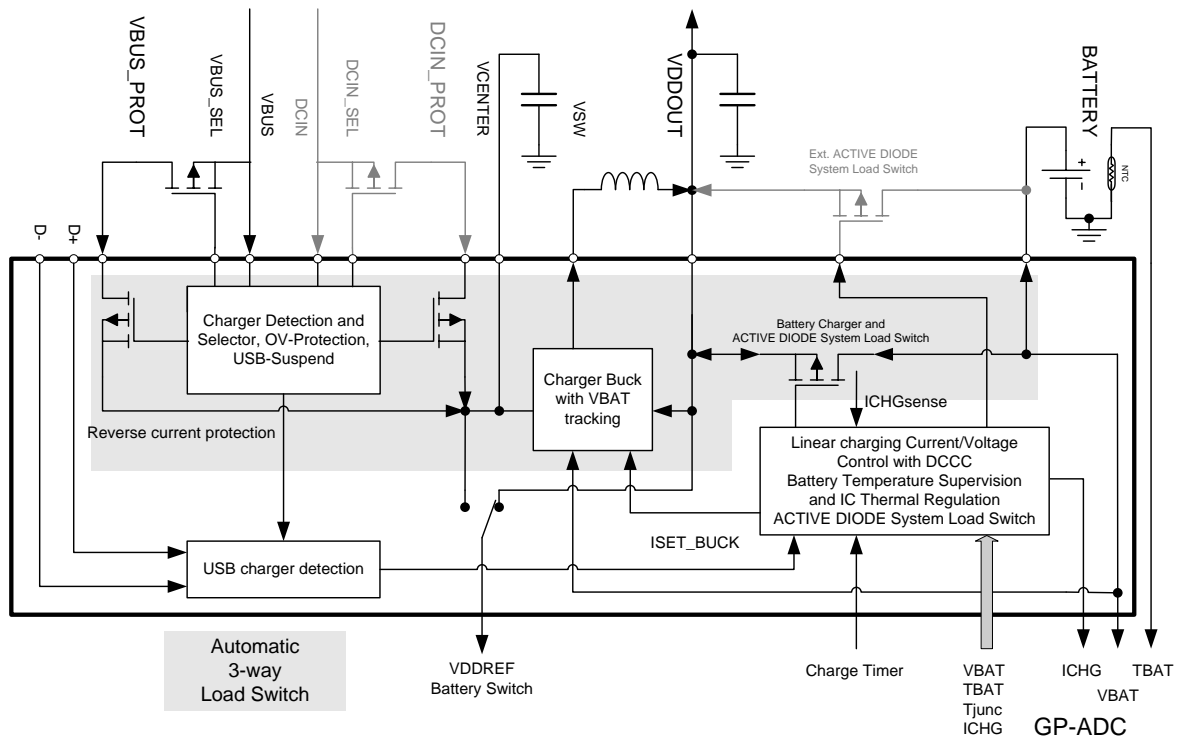

Figure 1: Charger block diagram

## DA9053's High Efficiency Autonomous Charger

### 2 External components

External components should be chosen by consideration of their parasitic characteristics (low DCR for the inductor, low MOSFET gate capacitance and  $R_{DS-ON}$ ) and voltage and current ratings. Capacitors should be X5R or X7R and coil saturation current at least 1.3 times greater than the maximum charger buck output current.

With reference to [Figure 1](#) and [Figure 2](#), the following components are the recommended external components for the charger to function correctly:

|         |                                 |                           |
|---------|---------------------------------|---------------------------|
| M1      | CSP 1.0 x 1.5 mm                | Ciclon CSD25301W1015      |
| M2      | CSP 1.0 x 1.5 mm                | Ciclon CSD25301W1015      |
| M1 + M2 | PowerPAK1212-8 3.3 x 3.3 x 1 mm | Vishay Siliconix Si7911DN |
| M3      | SOT-23 3 x 2.6 x 1 mm           | Vishay Siliconix Si2333DS |

|    |             |                |       |        |                 |                         |
|----|-------------|----------------|-------|--------|-----------------|-------------------------|
| L1 | 2.2 $\mu$ H | 4 x 4 x 1.2 mm | 2.5 A | +/-20% | 0.1 $\Omega$    | Coilcraft LPS4012-222NL |
|    |             | 4 x 4 x 1.8 mm | 3.0 A | +/-20% | 0.0504 $\Omega$ | Taiyo Yuden NRS4018     |

|        |               |      |     |        |       |                           |
|--------|---------------|------|-----|--------|-------|---------------------------|
| C1, C2 | 2.2 $\mu$ F   | 0603 | X5R | +/-10% | 16 V  | Murata GRM188R61C225KE15  |
| C3, C4 | 4.7 $\mu$ F   | 0603 | X5R | +/-10% | 6.3 V | Murata GRM188R71J475KE19D |
| C7     | 10 $\mu$ F    | 0805 | X7R | +/-10% | 10 V  | Murata GRM21BR70J106KE76L |
| C5     | 2x 10 $\mu$ F | 0805 | X7R | +/-10% | 10 V  | Murata GRM21BR70J106KE76L |
| C6     | 10 $\mu$ F    | 0805 | X7R | +/-10% | 10 V  | Murata GRM21BR70J106KE76L |

|     |               |      |       |                 |
|-----|---------------|------|-------|-----------------|
| TH1 | 10 k $\Omega$ | 0402 | +/-1% | NCP15XH103J03RC |
|-----|---------------|------|-------|-----------------|

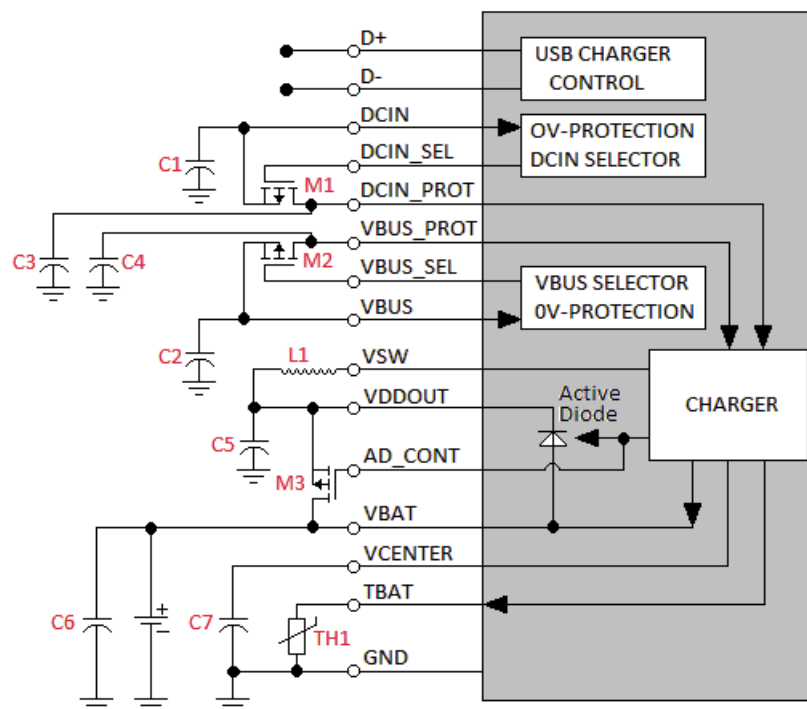

Figure 2: External components required for correct operation

## DA9053's High Efficiency Autonomous Charger

### 3 Choosing the right charger parameters

The charging process of a Lithium-Ion battery can be divided into three phases:

- pre-charge
- constant current (CC) fast charge
- constant voltage (CV) or top-off charge

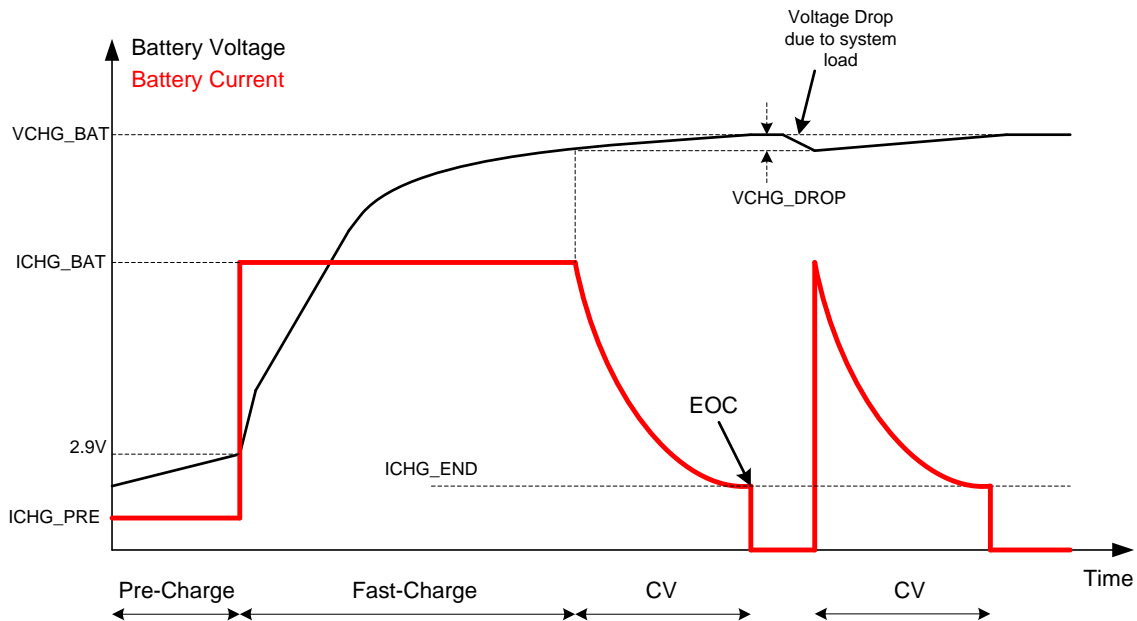

Figure 3: Li-Ion battery charge profile

#### 3.1 Pre-charge phase

If the battery voltage is lower than 2.9 V a pre-charge phase is started with a reduced current compared to ICHG\_BAT (see [Figure 3](#)). The pre-charge current ICHG\_PRE is selected in register R65<7:6>.

Battery pre-charge mode is started and controlled automatically by DA9053. This is needed to ensure that a completely empty battery can be charged without the intervention of the host processor.

The pre-charge also handles the re-enabling of a battery pack where the internal safety switch has been opened (due to deep discharge). The safety switch will be reset by applying a current through the diode into the safety switch, charging the battery cell up to about 2.8 V when the switch will be closed again. Using control BLINK\_FRQ, DA9053 can drive a flashing LED connected to GPO10 or GPO11 that will indicate battery charging. The flashing will stop when the application is able to power up.

#### ICHG\_PRE selection

Depending on the ICHG\_BAT value, ICHG\_PRE is suggested to have a value less than 10% of the nominal charging current in the fast-charge phase. The ICHG\_PRE value can be set to be 20 mA / 40 mA / 60 mA on register R65<7:6>, but should not be configured too low as this will cause the pre-charge phase to take longer than necessary.

## DA9053's High Efficiency Autonomous Charger

### 3.2 Constant current (CC) fast-charge phase

If  $2.9V < V_{BAT} < V_{CHG\_BAT}$  the DA9053's charger performs fast-charging with constant current. This can be configured via the ICHG\_BAT parameter.

#### ICHG\_BAT selection

ICHG\_BAT, selectable on register R65<5:0>, affects the charge time and the battery life.

Charging with higher ICHG\_BAT:

- + Increasing the charge current shortens the charge time. Although the end of the constant current phase is reached more quickly with a higher charge current, the constant voltage phase will take longer. Some chargers claim to fast-charge a Li-Ion battery in one hour or less. Such a charger eliminates the CV stage and goes directly to 'ready' once the voltage threshold is reached at the end of CC stage. The charge level at this point is about 70%. The topping charge typically takes twice as long as the initial charge.
- Moderate charging / discharging rates help to increase the number of cycles and thus the battery life. Lower charge current reduces the time in which the cell stays at its maximum voltage. (This is beneficial because prolonged high voltage promotes corrosion which shortens battery life).

For instance, the charge current of a cobalt-based Li-Ion battery should not be higher than 0.5C. Smaller batteries used for cell phones can be charged at 1C, and in general, when using a specific battery type, a balance should be found according to the priority given to the battery life or to the overall charging time.

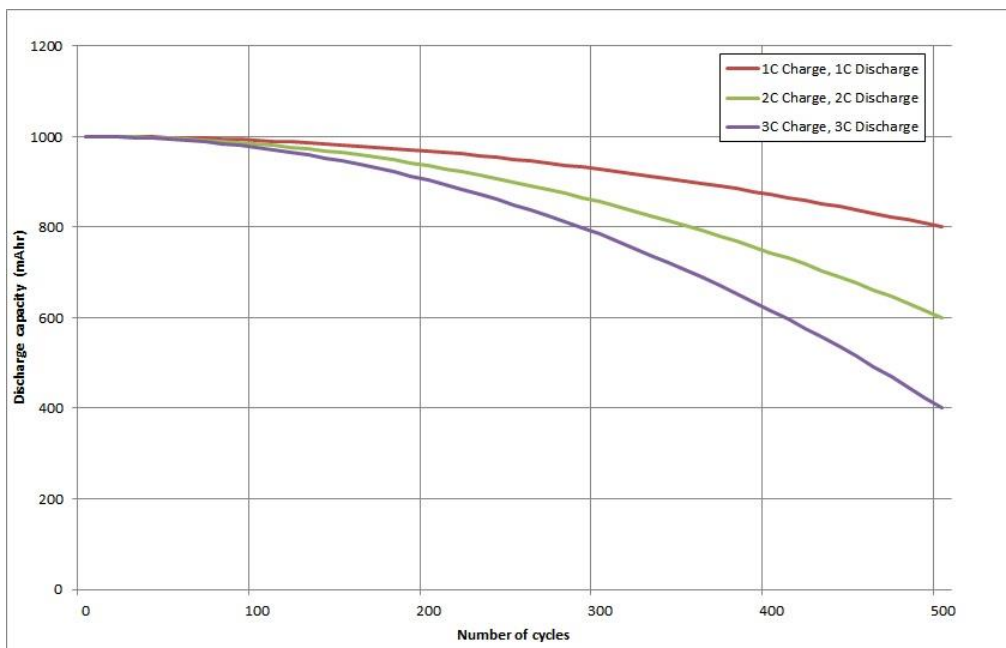

Figure 4: Cycle performance at various charge/discharge rates

## DA9053's High Efficiency Autonomous Charger

### 3.3 Constant Voltage (CV) phase

In this phase, a Li-Ion battery is close to its complete charge (also called 'top-off charge'). When the battery voltage is close to VCHG\_BAT, the constant voltage (CV) phase takes over. It is only in this phase that an End of Charge (EOC) condition can be detected and charging can be terminated.

The EOC condition is determined by the charge current threshold ICHG\_END, specified by R89<7:0>. To prevent battery deterioration from continuous top-off charging, a new cycle will start only if the battery voltage drops below the configurable re-charge threshold specified by:

$$\text{Recharge Threshold} = \text{VCHG\_BAT} - \text{VCHG\_DROP}$$

#### VCHG\_BAT selection

The VCHG\_BAT configures the target value for the battery voltage when fully charged. The value is selected in register R66<7:3> and can be set between 3.65 V and 4.425 V with 25 mV steps, covering a wide range of Li-Ion battery options.

The suggested value for most common Li-Ion cells is 4.2 V (4.1 V for Li-Polymer). However the configuration of this parameter requires careful consultation of the battery's datasheet as VCHG\_BAT has a significant influence on the safety of the overall application.

Setting VCHG\_BAT to lower target voltages:

- + Provides a longer battery life.
- Generally reduces the capacity and thus the on-time for running.

Setting VCHG\_BAT to higher target voltages:

- + Increases the capacity and thus the on-time for running applications.
- Is dangerous for overall safety, hence any overcharging must be avoided. Li-Ion batteries are designed to operate safely within their normal operating voltage but become unstable if charged to higher voltages. If a typical cell is charged above the normal operating voltage it causes plating of metallic lithium on the anode; the cathode material becomes an oxidizing agent, loses stability and releases oxygen. Overcharging causes the cell to heat up. If left unattended, the cell could burn, vent or explode.

#### VCHG\_DROP selection

The VCHG\_DROP parameter in register R67<6> is used to determine when the charging process of a discharging battery will be restarted following a successful End of Charge detection.

A self-discharged battery will be restarted if a battery charger is still connected and the system is supplied from the charger.

Low values of VCHG\_DROP allow the battery to remain close to its maximum capacity, thus maximizing the run-time. This comes at a cost in terms of increased number of charging cycles, causing reduced battery life.

The suggested value for this parameter is 200 mV for reduced battery deterioration.

## DA9053's High Efficiency Autonomous Charger

### ICHG\_END selection

The ICHG\_END parameter in register R89<7:0> configures the current threshold that terminates a charging cycle. The charging current is measured automatically by the GP-ADC every 1 ms or 10 ms (depending on setting of ADC\_MODE in register R82), and an average value is determined over the last 10 seconds, thus filtering and smoothing peaks and sudden changes.

The ICHG\_END parameter directly influences the duration of the charging phase and is typically set at a level lower than 10% of the selected ICHG\_BAT. Considering the example of a typical application with a battery capacity  $C = 1000$  mAh, charged at 1C rate, the appropriate value for ICHG\_END would be 100 mA or less. Different ICHG\_END values have the following effect:

- A lower value causes a longer charging time but results in a more completely charged battery (see [Figure 5](#)).
- A too high value can produce a premature end of charge with reduced available battery capacity.

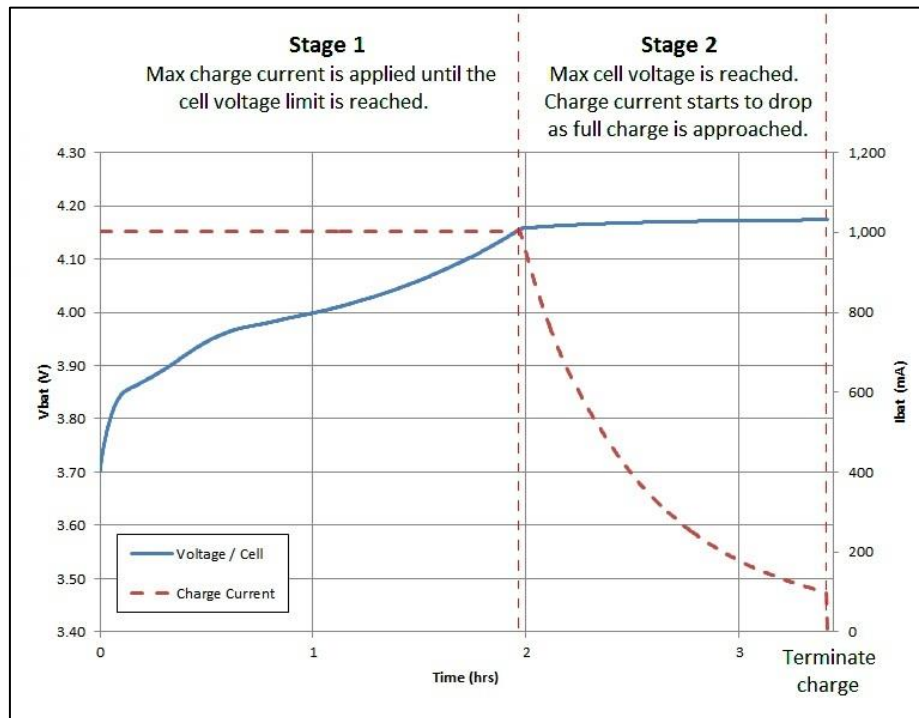

**Figure 5: Charge stages of a 4.2V Li-Ion Battery**

To achieve a completely charged battery charge time can be sacrificed by setting ICHG\_END to be less than 10% of ICHG\_BAT. With reference to the previous  $C = 1000$  mAh battery, a value of 50 mA is suggested instead of 100 mA.

## DA9053's High Efficiency Autonomous Charger

### 3.4 Connection and operation with DCIN / USB supplies

DA9053 implements a 3-way power path switch that automatically selects the power source for the system rail VDDOUT from either the wall charger DCIN, the USB connection VBUS or the Li-Ion battery VBAT. Preference is given in the order DCIN then USB VBUS and finally VBAT.

The charging source devices are classified based on the current that they are able to provide:

**Table 1: Charging input device types**

| Source | Characteristic  | Available Current |
|--------|---|-------------------|
| USB    | A USB hub or host: unconnected or suspended                                   | Up to 2.5 mA      |
| USB    | A USB hub or host: connected and not suspended, not enumerated                | Up to 100 mA      |
| USB    | A USB hub or host: connected and not suspended, enumerated                    | Up to 500 mA      |
| USB    | A USB host or hub charger: compliant with USB 2.0 specification               | Up to 1.5 A       |
| USB    | A USB dedicated charger: compliant with USB 2.0 specification                 | Up to 1.8 A       |
| DCIN   | A wall charger with voltage and current characteristics defined by the vendor | Vendor specific   |

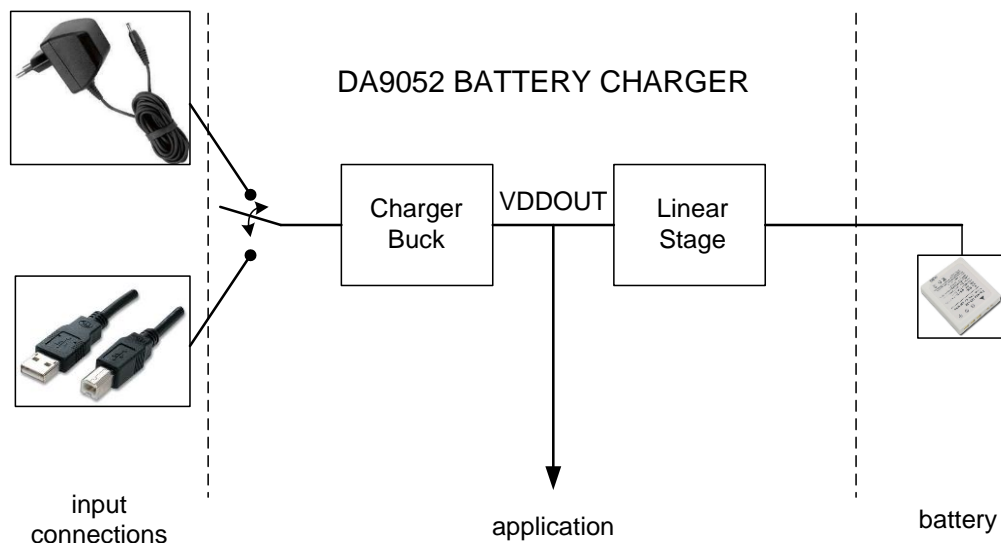

**Figure 6: Connections of DA9053 battery charger**

## DA9053's High Efficiency Autonomous Charger

### ISET\_BUCK / ISET\_DCIN / ISET\_USB selection

ISET\_BUCK can be set in register R62<3:0> and is the current limit for the charger buck stage of [Figure 6](#). Its OTP value should always be set to 100 mA if USB charging is to be used as this is the initial limit allowed. If the system is batteryless the value should be set to 1800 mA.

When a charger is detected, the value of this register is loaded from ISET\_DCIN or ISET\_USB. For USB, the detection of the charger can be performed by DA9053's internal circuitry or by a USB transceiver – see related chapter on page 17 for details. Once charging is active, the limit may be changed by writing to ISET\_BUCK via the control interface.

The charger buck has a very high efficiency. The use of a buck converter stage instead of a linear stage increases the overall charger efficiency and allows more (mean value) current to be supplied to the application than is drawn from the external supply.

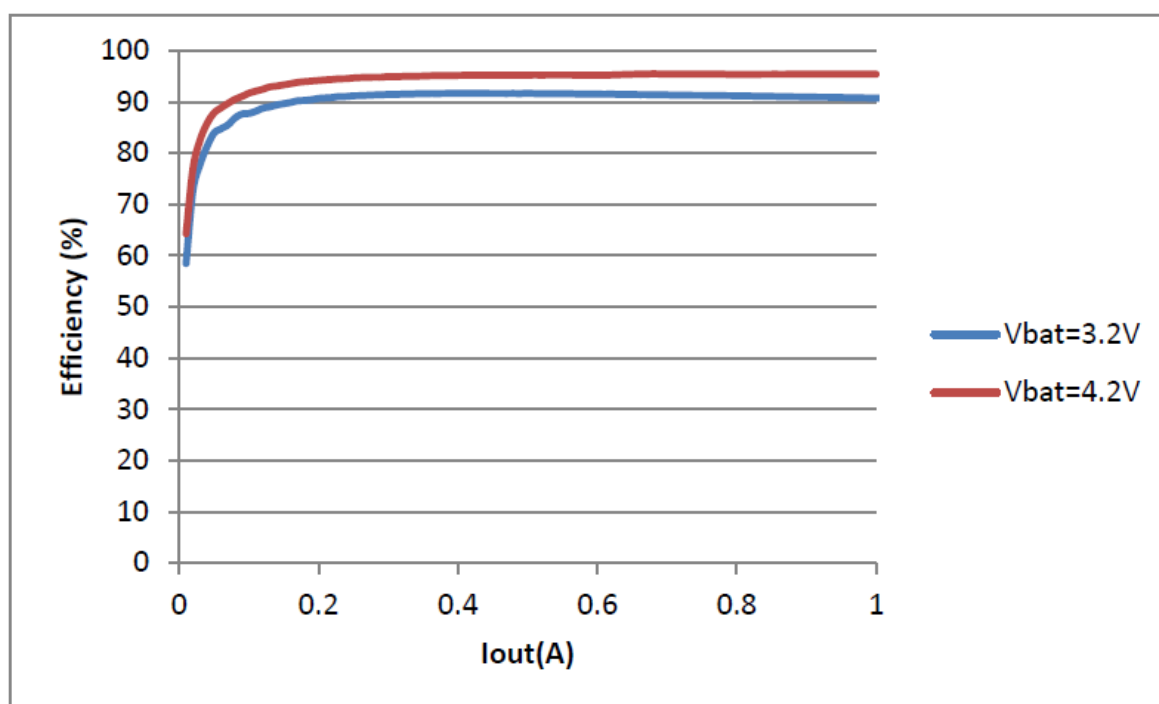

Figure 7: Typical efficiency of DA9053's charger buck

### VCHG\_THR selection

External chargers also have their power limitations. It is often the case that the external charger output voltage will drop drastically when a large amount of current is sourced. The reason for this could be due to the output impedance or the limitation of internal magnetic (and other) components.

The charger buck has a current limit, represented as a digital value in register R62<3:0>. If the current demands are bigger than those which the external charger can provide, the external charger output voltage will drop to a lower value. VCH\_THR value represents the input voltage low limit for DA9053 device, below which the ISET\_BUCK value is reduced. This is designed to prevent the external charger voltage from completely collapsing. With the buck current limit reduced, the external charger output voltage can stay in its 'safe zone' and will still be able to supply the system and charge the battery at the same time.

## DA9053's High Efficiency Autonomous Charger

By setting a low value of VCH\_THR, even collapsing supplies can be used and compatibility with the new USB3.0 charging standard can be achieved. (All hubs and peripheral devices are required to be operational down to 4 V with loads up to 900 mA current).

Care must be taken when setting low values. The lowest value of VCH\_THR for any system must be greater than the highest output voltage programmed for any of the regulators.

**NOTE**

Current limited chargers will provide more power at higher output voltages. Configuring VCH\_THR too low creates a risk that the external supply/charger disconnects due to overload.

The DA9053 charger has a charger attach comparator (CHG\_ATT). The comparator detects if there is a voltage drop of 100 mV or more across VCENTER and VDDOUT (see [Figure 1](#)) and acts together with the charge detection comparators as an under voltage lock-out.

With reference to [Figure 8](#), the following actions are performed if the charging source voltage collapses:

- Initially, the voltage at the charger input (DCIN or VBUS) falling below VCHG\_THR forces the charger buck state machine to reduce the charger buck current limit step-by-step down to its minimum value.
- If the input voltage does not recover above VCHG\_THR and the CHG\_ATT comparator flags a voltage drop from VCENTER to VDDOUT of less than 100 mV, the charger buck is disabled as soon as the current limit reaches its minimum value. The output of the comparator can be read at any time by the host on register R2.
- If the input voltage recovers, the state machine starts to increase the current limit again until it reaches its programmed value.

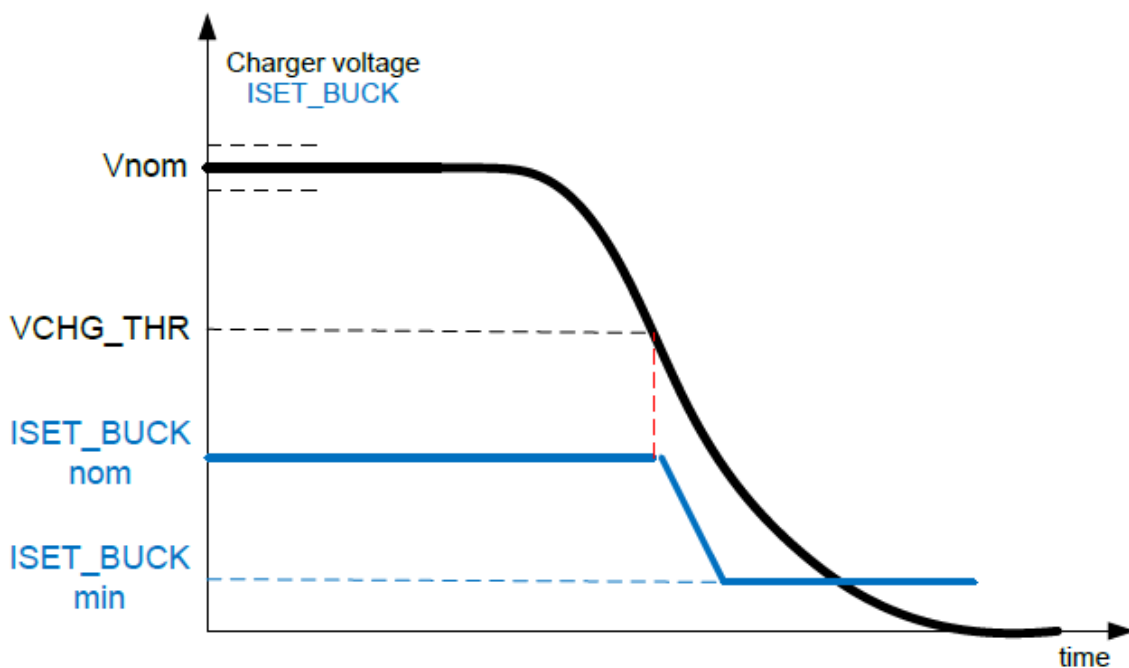

Figure 8: Profiles of charger current and voltage

## DA9053's High Efficiency Autonomous Charger

### Dynamic charging current control

The application system load ( $I_{sys}$ ) and the current for battery charging ( $I_{chg}$ ) form a combined load on the charger buck output rail VDDOUT. Depending on the current capability of the external charger source, charger buck current limit setting and system load level the following operating states will occur:

**Table 2: 3-way switch states**

| State | Load condition                           | Battery state                      |
|-------|--|------------------------------------|
| A     | $I_{sys} + I_{chg} < I_{buck}$           | Charging at up to ICHG_BAT current |
| B     | $I_{sys} + I_{chg} > I_{buck} > I_{sys}$ | Charging at reduced current level  |
| C     | $I_{sys} > I_{buck}$                     | Discharging                        |

- A. If the combined load does not exceed the input current limit ISET\_BUCK, then the charger buck delivers the needed load current without restrictions. In addition, the VDDOUT voltage will be regulated to 250 mV higher than VBAT to minimize the power consumption of the linear charger stage (see Figure 9).

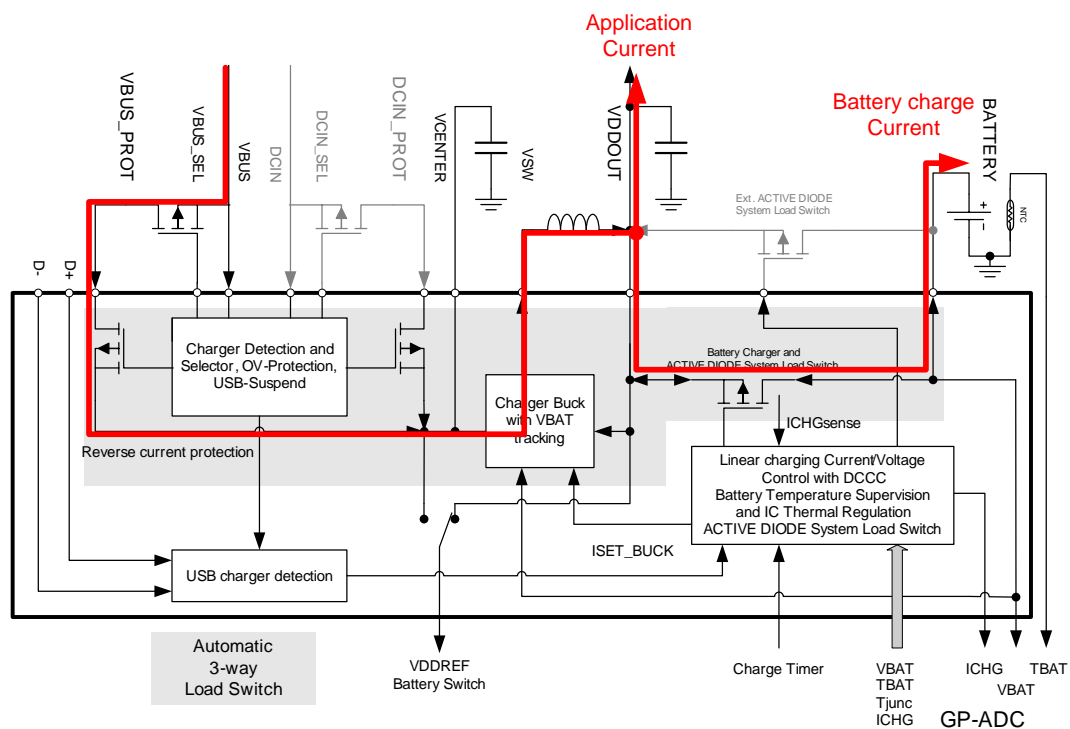

**Figure 9: ISET\_BUCK value is higher than (Application + Charging) current**

DA9053's High Efficiency Autonomous Charger

- B. If the combined load exceeds the input current limit ISET\_BUCK, the linear charger stage automatically reduces the battery charge current to keep supplying the required system power. This is realised by reducing VDDOUT down to VBAT, which consequently reduces the charging current. It is then possible to charge the battery with any surplus current that is not required by the application (see Figure 10).

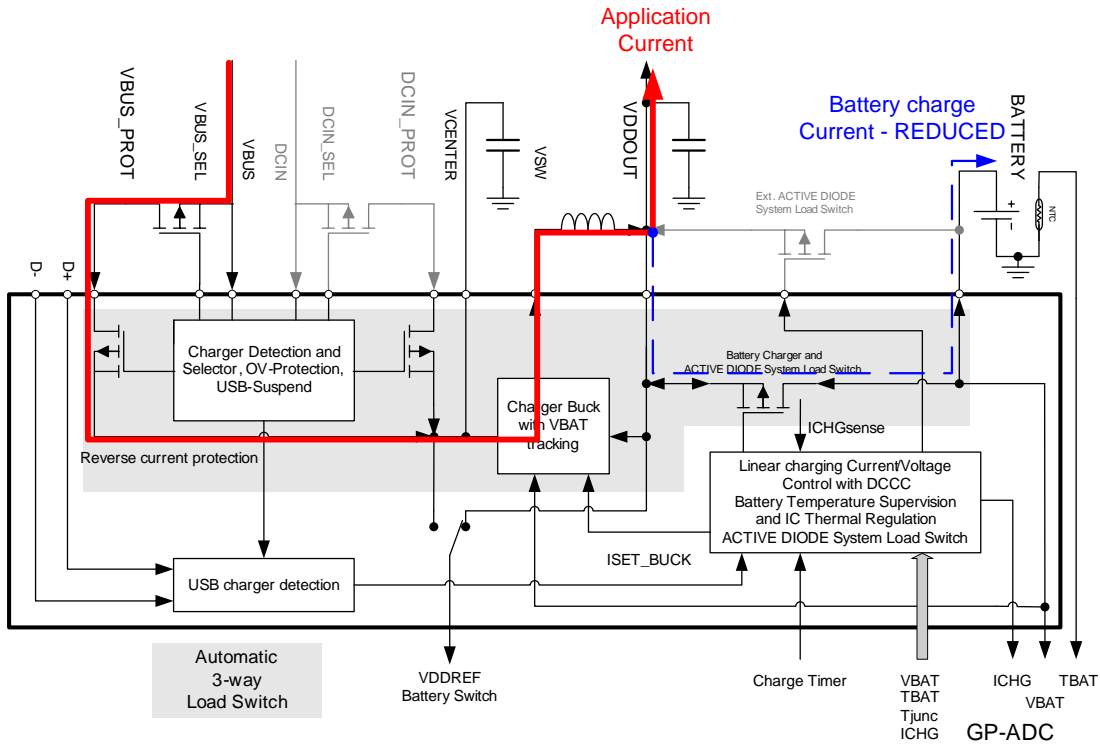

Figure 10: Current path from valid USB according to state B.

## DA9053's High Efficiency Autonomous Charger

- C. If the application load alone exceeds input current limit ISET\_BUCK, the battery linear charger shuts off completely and the extra power is drawn from the battery via the active diode (see [Figure 11](#)).

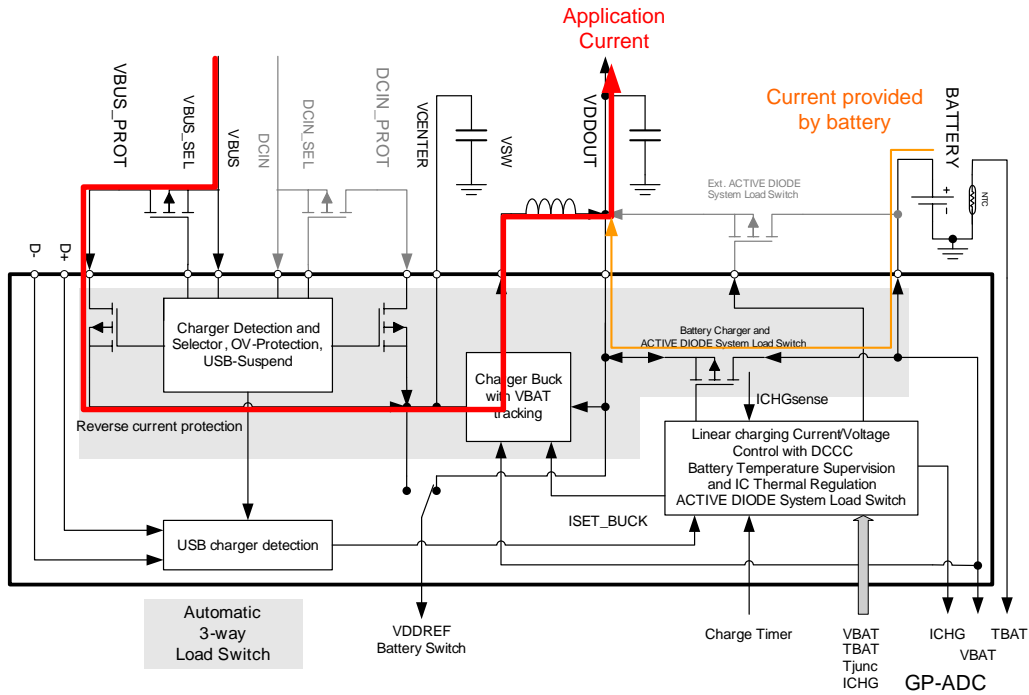

Figure 11: Current path from valid USB according to state C.

## DA9053's High Efficiency Autonomous Charger

Figure 12 shows a DA9053 charger measurement with a USB supply connected with ISET\_BUCK = 500 mA.

In the first phase, the battery is charged with ICHG\_BAT = 300 mA. The system load increases on VDDOUT and the USB input is able to provide the needed current ( $I_{usb}$ ).

When the USB input current reaches 500 mA and the load increases further, the battery charge current ( $I_{bat}$ ) is reduced.

In the final phase, the battery is no longer charging and instead now contributes to supplying the application load current.

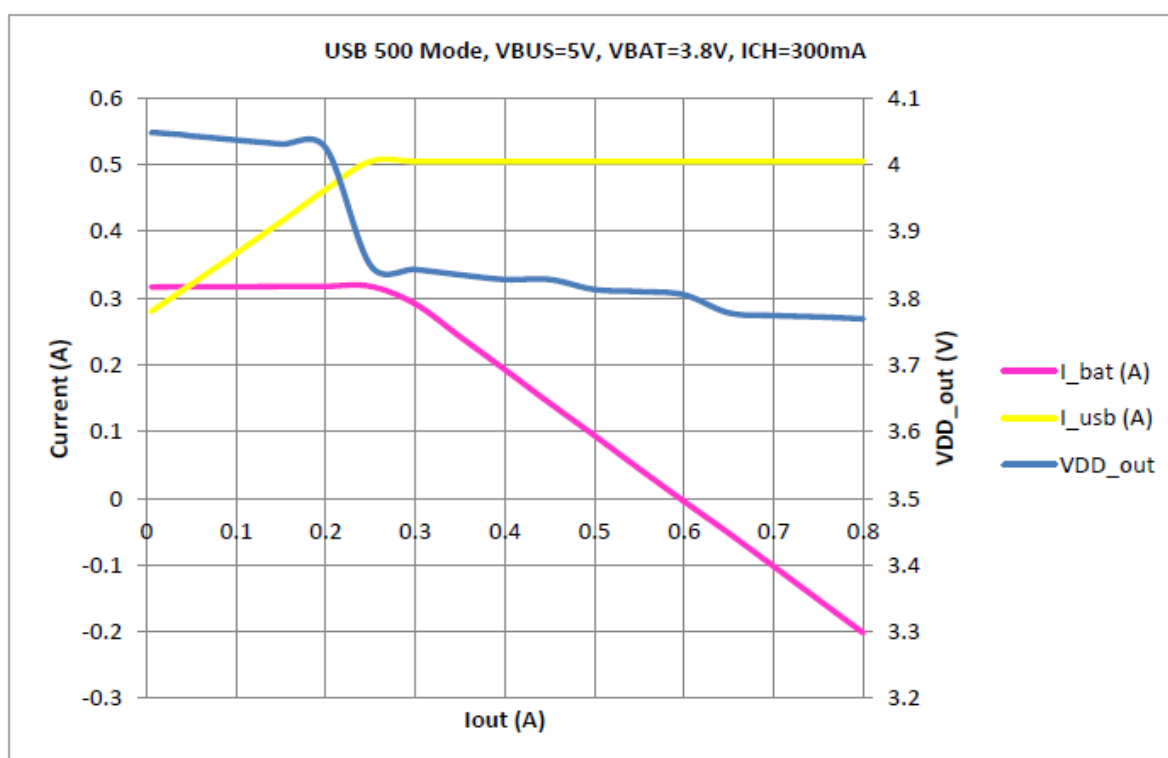

**Figure 12: Power path, charger and system load measurements.**

### NOTE

DA9053 switching charger always provides more current to the system ( $I_{bat} + I_{load}$ ) than drawn from VBUS ( $I_{usb}$ ) which reduces power dissipation and increases efficiency. It allows faster charging and a higher system load from a current limited supply (e.g. up to 700 mA from a USB 500 mA charger).

As shown in [Figure 12](#), the active diode not only allows current flow into the battery for charging purposes, but also in the opposite direction. This occurs automatically as soon as the VDDOUT voltage drops below VBAT. When the active diode is engaged, it has approximately 140 mΩ on resistance. If a lower resistance is needed, an external MOSFET should be used to supplement the internal active diode. It must be connected on the board and activated in control register R15 (0x0F).

A MOSFET such as the Vishay Si2333 is suited to the purpose. (Qualitative results are shown in [Figure 13](#)).

DA9053's High Efficiency Autonomous Charger

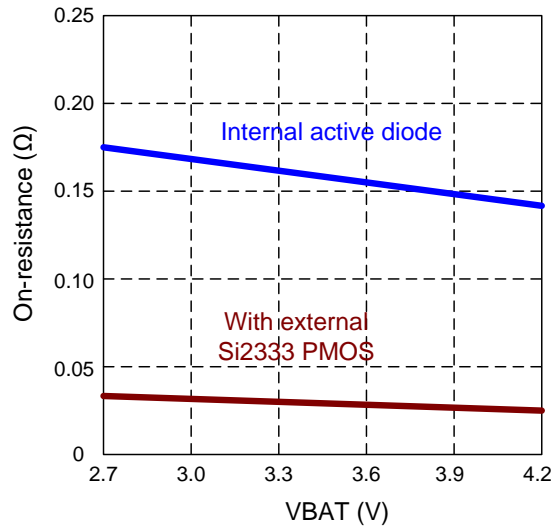

Figure 13: On-resistance of internal and external active diode.

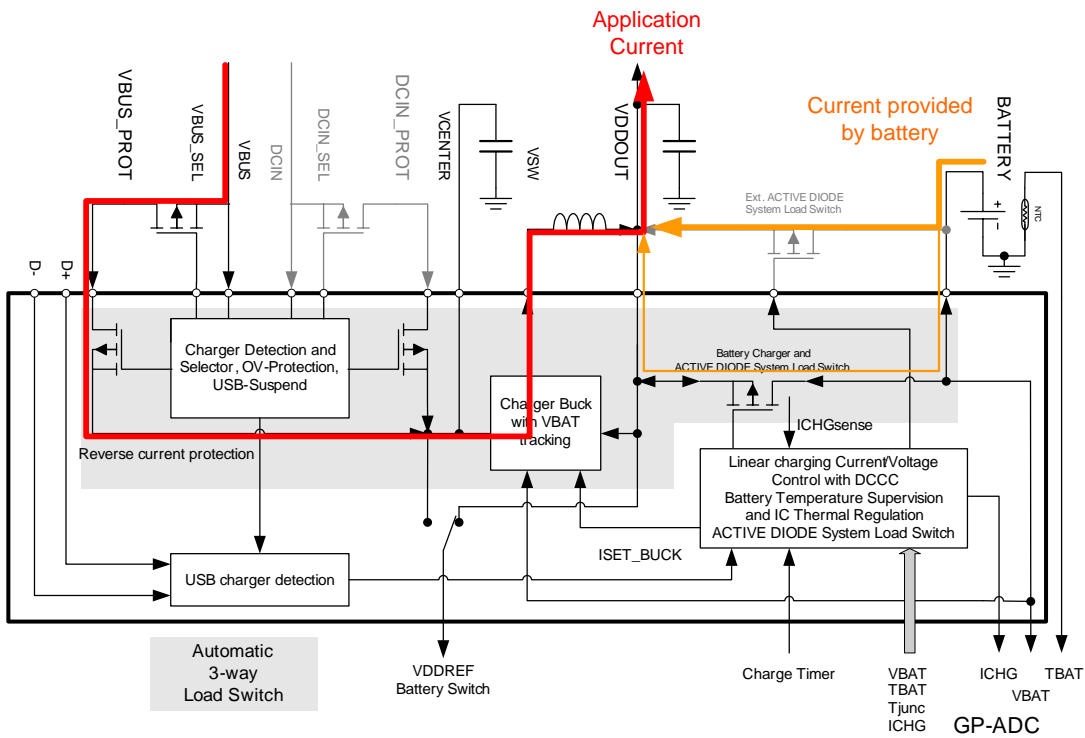

Figure 14: Current path from valid USB according to state C and external active diode

## DA9053's High Efficiency Autonomous Charger

### 3.5 CHG\_USB\_ILIM setting and use of D+ / D-

Control CHG\_USB\_ILIM in DA9053 register R62<6> can be set either to 'Auto' or 'Not Auto' which determines the method of USB detection.

If the target application system has a USB PHY device that can be powered from the USB connection, special care must be taken not to disturb the USB interface during auto detection. In this case, the auto option should be disabled or a different type of connection between USB lines and DA9053 input terminals should be used. For example, a dedicated line from USB PHY to the D- pin of DA9053 with 'Auto' option enabled.

With CHG\_USB\_ILIM set to 'Not Auto' the value of ISET\_BUCK is loaded from either ISET\_DCIN or ISET\_USB (depending on which charger is detected) or from ISET\_DCIN if both chargers are present.

In the case of a USB powered PHY with a logic level connection to the D- terminal of DA9053, when the PHY detects a dedicated charger, it should set the logic signal to 'high', which will indicate that the current limit for ISET\_BUCK should be loaded from ISET\_USB.

In the case of a USB PHY that is powered by the DA9053, CHG\_USB\_ILIM should be set in the OTP. After the USB PHY has been powered, the host processor should disable the auto-detect function by writing '0' to R62<6>. Disabling the auto-detect function once the system is powered will prevent the auto-detect function from interfering with an active USB interface.

With the USB PHY and host processor powered, the decision about ISET\_BUCK should be made by the user software and set through I2C (or SPI) communication.

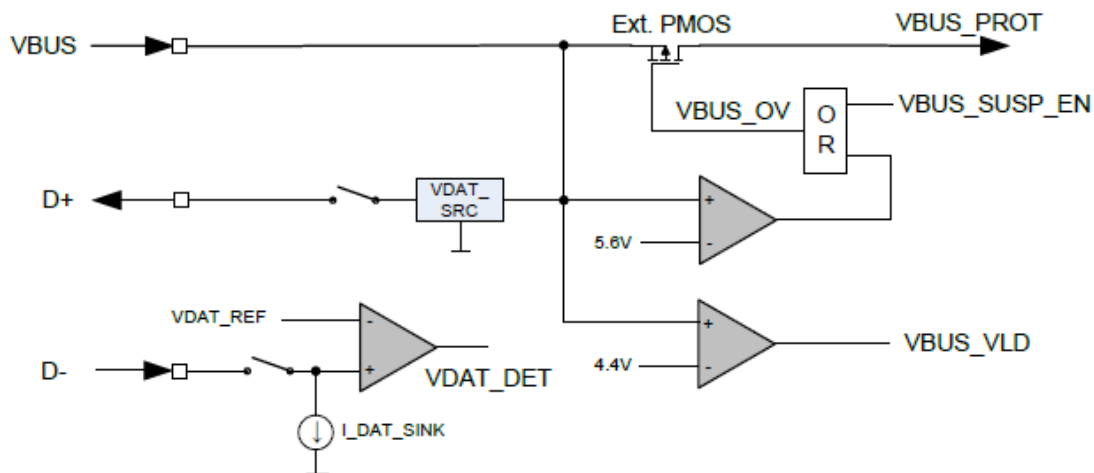

Figure 15: USB Charger detection

Dialog always recommends using the setting CHG\_USB\_ILIM = 1 in OTP which allows the device to auto-detect the charger parameters.

## DA9053's High Efficiency Autonomous Charger

The USB Battery Charging Specification recommends that the PMIC plays an active role in charger supply detection. After a portable device detects VBUS, it is permitted to check whether the attached device is a charger. This is done applying a voltage to D+ and checking the voltage on D-.

When a USB device has been attached to VBUS and CHG\_USB\_ILIM = 1 (set in the OTP registers), DA9053:

1. Exits RESET mode and reads the OTP setting after a 10ms debounce.
2. Drives the D+/D- circuitry (assuming the external USB PHY is still off) to detect the attached device type at VBUS. For a dedicated charger DA9053 has to detect a short between D+ and D- with a maximum resistance of 200  $\Omega$ .

A dedicated wall charger or USB host/hub charger is differentiated from a USB host/hub and can usually provide charging currents greater than 100 mA.

According to the USB Battery Charging Specification, if a charger is detected by the D+/D- circuitry, a higher charging current can be drawn and the system can power up with this higher current.

An alternative option to allowing the DA9053 to directly detect the type of USB device connected is a USB PHY with built in charger detection. In this case it would be possible to connect the logical output from the USB PHY to the D- input of the DA9053. Care must be taken with the polarity of the logical output from the PHY. The most attractive benefit of this approach is that the sensitive D+ and D- signals do not have to be routed both to the PHY and to the DA9053.

The D- connection of the DA9053 can also be utilised as a charger select signal. While the primary intention of this signal is to detect a USB charger, it can also be used to set the charge current for 2 different types of charger e.g. a standard charger and a Turbo charger. To use the D- in this way, the ISET\_BUCK and ISET\_USB values would have to be set accordingly and a method of pulling the D- input high or low depending on the physical charger attached. A logic high on D- will select the ISET\_USB value and a logic low will select the ISET\_BUCK value.

It is also possible that the application cannot start due to a dead or weak battery and DA9053 D+/D- has detected a USB supply with a limited current capability (such as a 100 mA normal host or hub, not charger).

In this case the application will try to start-up but as the supply cannot provide enough power, the system voltage will collapse when the current is drawn, and DA9053 will sequence back into RESET mode from detection of a VDD\_FAULT condition. When reaching RESET mode the application will automatically stop drawing current and the external supply will usually recover. Applications that use Auto Boot to automatically boot up whenever an external supply is detected would then fall into an endless shutdown-reboot loop (supply lockout) and would not be able to power up from this supply.

For this condition DA9053 provides an additional 'Emergency Charge' mode.

In Emergency Charge mode Auto Boot will be temporally disabled and only the battery is charged with the available current. The DA9053 GPO10 and GPO11 can be configured to blink automatically when in Emergency Charge. This is to provide notification to the user that the system is not currently able to start. Once the battery has charged to a suitable level the application can start-up normally.

### 3.6 CHG\_TEMP

The CHG\_TEMP bit is set in R62 <7>. During charging the temperature of DA9053 (T<sub>junc</sub>) is continuously monitored by the GP-ADC to prevent overheating. A thermal supervision circuit reduces the charge current via a current/temperature control whenever the die temperature attempts to rise above a preset value of TCHARGELOW (90 °C). It completely suspends charging when TCHARGESUSPEND (120 °C) has been reached. This protects the DA9053 from excessive temperature, but allows the application to push the limits of the power handling capability of a given circuit board without risk of damage. Another benefit of the thermal limit is that the charge current can

## DA9053's High Efficiency Autonomous Charger

be set according to typical, not worst-case, ambient temperatures for a given application with the assurance that the charger will automatically reduce the current in worst-case conditions.

Whenever the package temperature crosses a threshold described in [Table 1](#), the thermal control will raise the (internal) temperature class and reduce the battery charge current limit towards the related value. It will increase the charge current limit only if the temperature drops below the Class 1 threshold. This prohibits a continuous change of the charging current around a temperature threshold.

The thermal charge current control can be disabled by setting the bit 7 of R62 to '0', but this will increase the risk of a complete thermal shutdown being triggered by the internal temperature supervisor under high power application scenarios.

**Table 3: Thermal charge current control**

| T <sub>junc</sub> (°C) | Class | Charge current limit (mA) | ICHG_BAT (Register value) |
|------------------------|-------|---------------------------|---------------------------|
| <90                    | 0     | 1890                      | 111111                    |
| >90                    | 1     | 1650                      | 110111                    |
| >95                    | 2     | 1350                      | 101101                    |
| >100                   | 3     | 1050                      | 100011                    |
| >105                   | 4     | 750                       | 011001                    |
| >110                   | 5     | 450                       | 001111                    |
| >115                   | 6     | Charging suspended        | 000000                    |

### 3.7 Battery temperature qualification

Before charging is allowed to commence, the DA9053 verifies that the battery is within a configurable temperature range. The Battery Temperature measurement is performed via ADC channel 2. ADC channel 2 has an integrated 50µA current source to simplify temperature measurements using a 10kΩ NTC thermistor. The ADC reading is qualified against three thresholds:

- TBAT\_HIGHP (R91): If the TBAT reading is higher than this value charging will be stopped.
- TBAT\_HIGHN (R92): This is the threshold that the TBAT reading must drop to before charging can resume following an over temperature event.
- TBAT\_LOW (R93): This is the lower temperature threshold. Charging will not start if the TBAT reading is below this threshold.

The values of these thresholds should be set according to the specific battery being used in the system. As a guide, TBAT\_HIGHP is normally set to 50 °C, TBAT\_HIGHN to 45 °C and TBAT\_LOW to 0 °C. The 'Charger Config' tab in the 'Power Commander' software provides further help in calculating the ADC values for specific temperatures for a 10 kΩ NTC.

## DA9053's High Efficiency Autonomous Charger

### 4 Summary and conclusion

The first step in determining the optimal charging parameters is to obtain the correct battery data, namely its capacity, voltage and type. The OTP settings can then be set to reflect the applied battery data:

- Register R62 (CHG\_BUCK):
  - CHG\_TEMP <7> should always be set to '1'.
  - CHG\_USB\_ILIM <6> should be set to 1 if USB charger auto detect functionality is required. The host processor should decide how to set this bit after the application starts.
  - CHG\_BUCK\_LP <5>: Setting this bit will put the charger buck in 'sleep' mode. In most applications this is not recommended; it is recommended in battery-less applications only where the system is able to operate in a reduced current state. This bit should always be set to '0' in OTP.
  - CHG\_BUCK\_EN <4> should be set to '1' in OTP.
  - ISET\_BUCK <3:0> should generally be set as default to 100 mA.
- Register R64 (ISET):
  - ISET\_DCIN <7:4>: Whenever the DC\_IN voltage is detected (which has priority over the other sources), the device loads this value into the ISET\_BUCK current limit register. The value represented by these bits depends on the application, the used battery capacity and the applied voltage source capability.
  - ISET\_USB <3:0>: When a voltage is applied to the VBUS pin and the auto detection detects that a dedicated charger is connected (by measuring the resistance between D- and D+ pins) the charger current limit is taken from this location. If a standard USB connection is detected, the limit programmed into the ISET\_BUCK register is used. This is normally 100 mA.
- Register R65 (BAT\_CHG):
  - ICHG\_PRE <7:6>: Charging current for depleted batteries. This should be about 1/10 of the nominal charging current ICHG\_BAT.
  - ICHG\_BAT <5:0>: Nominal charging current used in constant current phase.
- Register R66 (CHG\_CONT):
  - VCHG\_BAT <7:3>: Target voltage for charging. Use battery manufacturer recommended values, normally 4.2 V for Li-Ion, or 4.1 V for Li-Polymer.
  - VCHG\_THR <2:0>: The charger buck reduces its current limit if the input voltage falls below this value. Dialog recommends setting this above 4.35 V.

Typically, a good approach is to set all of the parameters in OTP and check the battery TBAT pin only. If the battery is connected, the charger will notice the battery's built in thermistor and activate the charger block.

Care must be taken with regards PCB layout of the charger buck function and reference should be made to Dialog's recommended PCB layout rules AN-PM-010. In particular care should be taken to ensure the VCENTER capacitor is placed on the same side of PCB as and as close as possible to the VCENTER ball of the DA9053.

---

**DA9053's High Efficiency Autonomous Charger****Revision history**

| Revision | Date         | Description                |
|----------|--------------|----------------------------|
| 1.0      | 05-June-2012 | Initial version.           |
| 2.0      | 14-Oct-2015  | Update to new template.    |
| 2.1      | 18-Febr-2016 | Typographical corrections. |

## DA9053's High Efficiency Autonomous Charger

### Status definitions

| Status               | Definition   |
|----------------------|--|
| DRAFT                | The content of this document is under review and subject to formal approval, which may result in modifications or additions. |
| APPROVED or unmarked | The content of this document has been approved for publication.  |

### Disclaimer

Information in this document is believed to be accurate and reliable. However, Dialog Semiconductor does not give any representations or warranties, expressed or implied, as to the accuracy or completeness of such information. Dialog Semiconductor furthermore takes no responsibility whatsoever for the content in this document if provided by any information source outside of Dialog Semiconductor.

Dialog Semiconductor reserves the right to change without notice the information published in this document, including without limitation the specification and the design of the related semiconductor products, software and applications.

Applications, software, and semiconductor products described in this document are for illustrative purposes only. Dialog Semiconductor makes no representation or warranty that such applications, software and semiconductor products will be suitable for the specified use without further testing or modification. Unless otherwise agreed in writing, such testing or modification is the sole responsibility of the customer and Dialog Semiconductor excludes all liability in this respect.

Customer notes that nothing in this document may be construed as a license for customer to use the Dialog Semiconductor products, software and applications referred to in this document. Such license must be separately sought by customer with Dialog Semiconductor.

All use of Dialog Semiconductor products, software and applications referred to in this document are subject to Dialog Semiconductor's [Standard Terms and Conditions of Sale](#), unless otherwise stated.

© Dialog Semiconductor. All rights reserved.

### RoHS Compliance

Dialog Semiconductor complies to European Directive 2001/95/EC and from 2 January 2013 onwards to European Directive 2011/65/EU concerning Restriction of Hazardous Substances (RoHS/RoHS2).

Dialog Semiconductor's statement on RoHS can be found on the customer portal <https://support.diasemi.com/>. RoHS certificates from our suppliers are available on request.

## Contacting Dialog Semiconductor

#### United Kingdom (Headquarters)

*Dialog Semiconductor (UK) LTD*  
Phone: +44 1793 757700

#### Germany

*Dialog Semiconductor GmbH*  
Phone: +49 7021 805-0

#### The Netherlands

*Dialog Semiconductor B.V.*  
Phone: +31 73 640 8822

#### Email:

[enquiry@diasemi.com](mailto:enquiry@diasemi.com)

#### North America

*Dialog Semiconductor Inc.*  
Phone: +1 408 845 8500

#### Japan

*Dialog Semiconductor K. K.*  
Phone: +81 3 5425 4567

#### Taiwan

*Dialog Semiconductor Taiwan*  
Phone: +886 281 786 222

#### Web site:

[www.dialog-semiconductor.com](http://www.dialog-semiconductor.com)

#### Singapore

*Dialog Semiconductor Singapore*  
Phone: +65 64 8499 29

#### Hong Kong

*Dialog Semiconductor Hong Kong*  
Phone: +852 3769 5200

#### Korea

*Dialog Semiconductor Korea*  
Phone: +82 2 3469 8200

#### China (Shenzhen)

*Dialog Semiconductor China*  
Phone: +86 755 2981 3669

#### China (Shanghai)

*Dialog Semiconductor China*  
Phone: +86 21 5424 9058

## IMPORTANT NOTICE AND DISCLAIMER

RENESAS ELECTRONICS CORPORATION AND ITS SUBSIDIARIES (“RENESAS”) PROVIDES TECHNICAL SPECIFICATIONS AND RELIABILITY DATA (INCLUDING DATASHEETS), DESIGN RESOURCES (INCLUDING REFERENCE DESIGNS), APPLICATION OR OTHER DESIGN ADVICE, WEB TOOLS, SAFETY INFORMATION, AND OTHER RESOURCES “AS IS” AND WITH ALL FAULTS, AND DISCLAIMS ALL WARRANTIES, EXPRESS OR IMPLIED, INCLUDING, WITHOUT LIMITATION, ANY IMPLIED WARRANTIES OF MERCHANTABILITY, FITNESS FOR A PARTICULAR PURPOSE, OR NON-INFRINGEMENT OF THIRD-PARTY INTELLECTUAL PROPERTY RIGHTS.

These resources are intended for developers who are designing with Renesas products. You are solely responsible for (1) selecting the appropriate products for your application, (2) designing, validating, and testing your application, and (3) ensuring your application meets applicable standards, and any other safety, security, or other requirements. These resources are subject to change without notice. Renesas grants you permission to use these resources only to develop an application that uses Renesas products. Other reproduction or use of these resources is strictly prohibited. No license is granted to any other Renesas intellectual property or to any third-party intellectual property. Renesas disclaims responsibility for, and you will fully indemnify Renesas and its representatives against, any claims, damages, costs, losses, or liabilities arising from your use of these resources. Renesas' products are provided only subject to Renesas' Terms and Conditions of Sale or other applicable terms agreed to in writing. No use of any Renesas resources expands or otherwise alters any applicable warranties or warranty disclaimers for these products.

(Disclaimer Rev.1.01)

### Corporate Headquarters

TOYOSU FORESIA, 3-2-24 Toyosu,  
Koto-ku, Tokyo 135-0061, Japan  
[www.renesas.com](http://www.renesas.com)

### Trademarks

Renesas and the Renesas logo are trademarks of Renesas Electronics Corporation. All trademarks and registered trademarks are the property of their respective owners.

### Contact Information

For further information on a product, technology, the most up-to-date version of a document, or your nearest sales office, please visit [www.renesas.com/contact-us/](http://www.renesas.com/contact-us/).