

Technical Note

DA7219 Updated Ball-out

Abstract

This document describes the changes made to the ball-out of the DA7219 device to add a GND_HP ball.

Contents

1 Reason for change 3

2 Ball-out Change 3

3 Schematic Change..... 3

4 PCB Routing Change..... 3

5 Conclusion..... 3

6 Revision history 7

Figures

Figure 1 Comparison of original ball-out to new ball-out (changes highlighted in red) 4

Figure 2 Original Schematic vs Updated schematic (changes circled in red) 5

Figure 3 Original Layout vs Updated Layout 6

1 Reason for change

DA7219 uses internal switches to support both OMTP and CTIA headsets. In order to support both headset types the ground return for the headphones must pass through the device. To minimise the die area of the DA7219 device a single ground ball was used for both this headset ground and the sensitive analogue ground. The impedance of the ball, trace and via, although small, is not zero therefore some noise from the headphone ground return is coupled onto the sensitive analogue circuitry. Following bench evaluation of DA7219 it has become clear that we need to separate these into two separate ground balls, one for the headset return and another for the internal analogue circuitry. This proposed solution has been verified in hardware and proved to resolve the issue.

2 Ball-out Change

The new ground ball replaces the VDD_DIG ball and moves 7 balls to allow for optimal placement of the new ball. The VDD_DIG ball was previously used to attach a bulk capacitor to the output of the internal digital supply LDO. This LDO is not required so this ball has been repurposed as a ground. The updated ball-out can be seen in Figure 1.

3 Schematic Change

The reference schematic has been updated for the updated ball-out. A comparison between the original schematic and the updated schematic is shown in Figure 2. The ball-out change saves one capacitor compared to the original.

4 PCB Routing Change

The reference layout has been updated for the updated ball-out. A comparison between the original layout and the updated layout is shown in Figure 3.

5 Conclusion

The new DA7219 ball-out offers improved performance thanks to its dedicated GND_HP ball. The ball-out change is minimal and has a minor effect on the schematic or PCB layout.

Original Ball-out

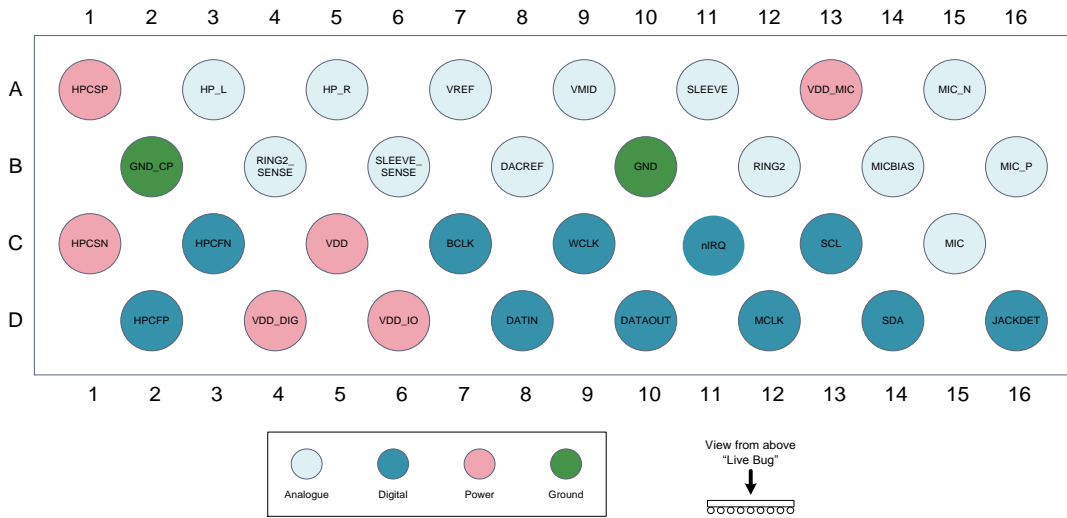

New Ball-out

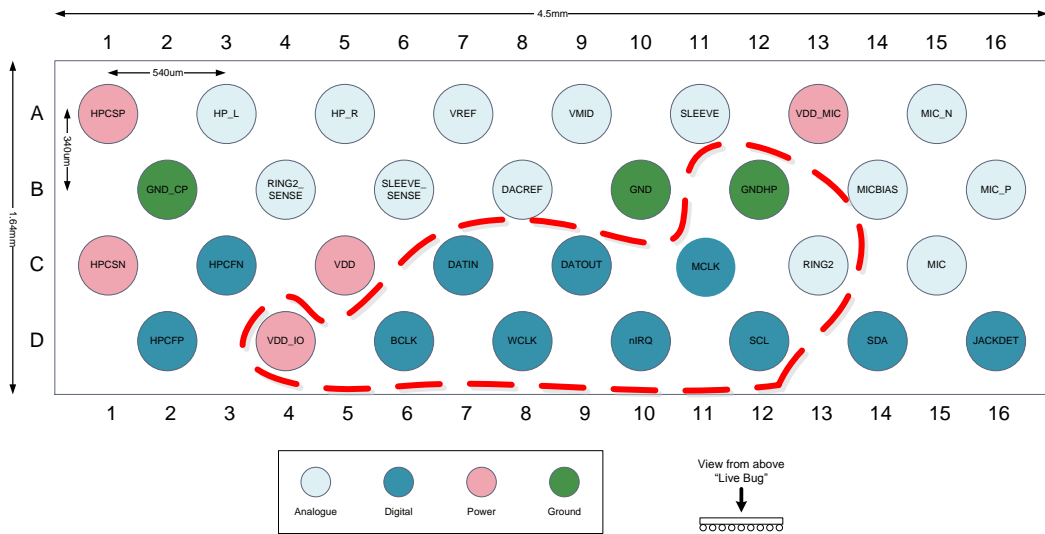

Figure 1 Comparison of original ball-out to new ball-out (changes highlighted in red)

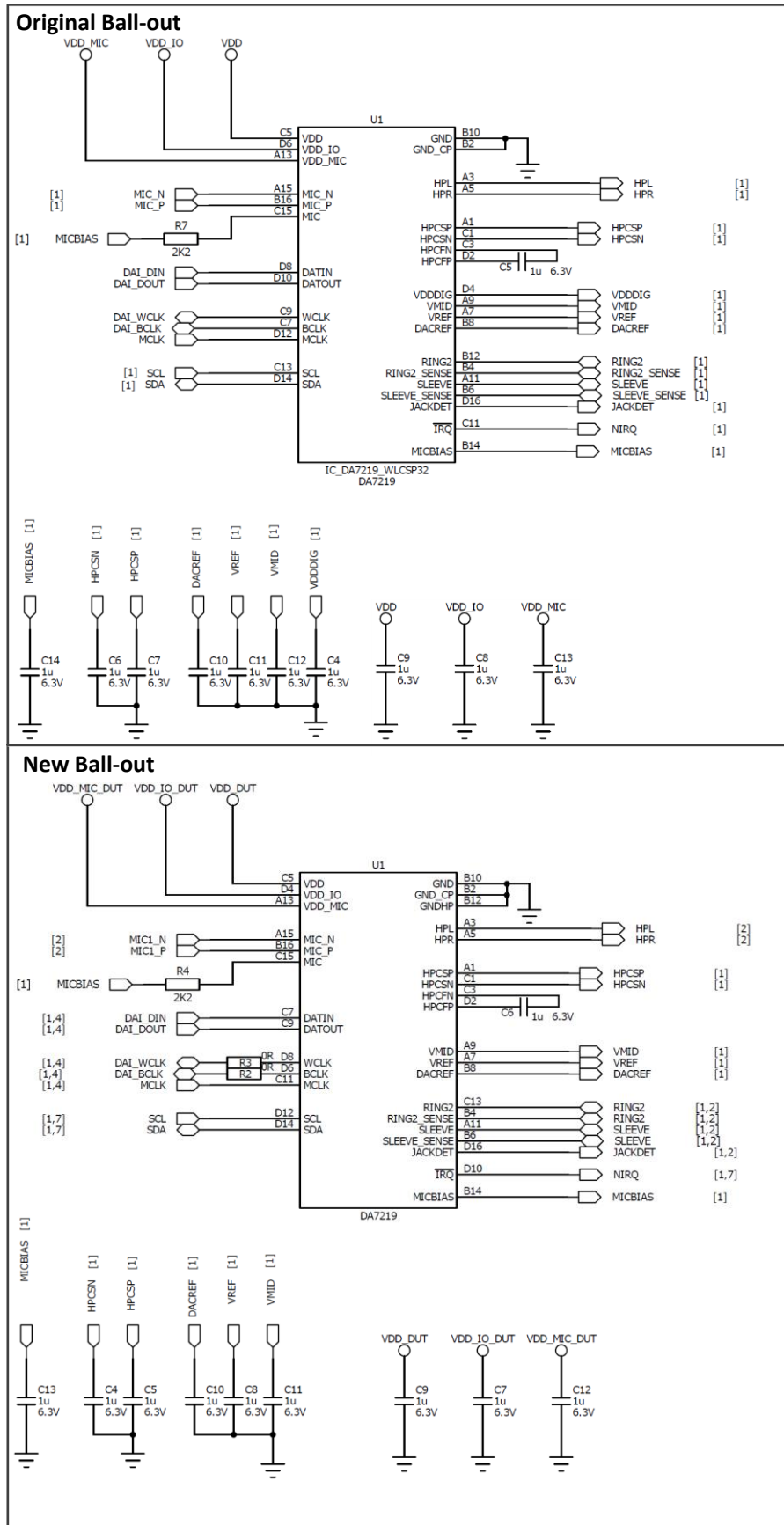

Figure 2 Original Schematic vs Updated schematic

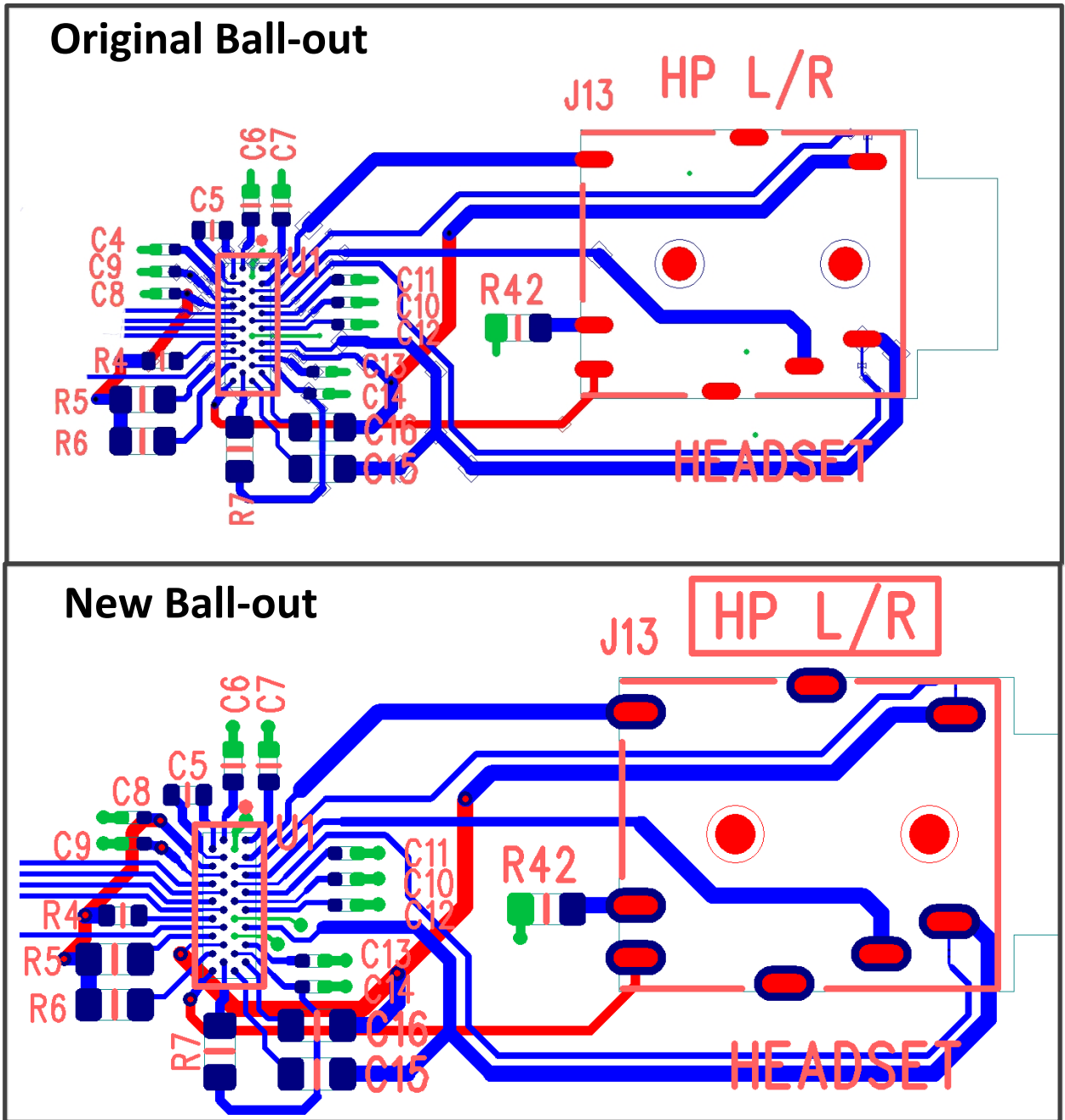

Figure 3 Original Layout vs Updated Layout

6 Revision history

Revision	Date	Description
1.0	03-11-2015	Initial version.
1.1	21-01-2022	Updated logo, disclaimer, copyright.

Status definitions

Status	Definition
DRAFT	The content of this document is under review and subject to formal approval, which may result in modifications or additions.
APPROVED or unmarked	The content of this document has been approved for publication.

RoHS Compliance

Dialog Semiconductor's suppliers certify that its products are in compliance with the requirements of Directive 2011/65/EU of the European Parliament on the restriction of the use of certain hazardous substances in electrical and electronic equipment. RoHS certificates from our suppliers are available on request.

IMPORTANT NOTICE AND DISCLAIMER

RENESAS ELECTRONICS CORPORATION AND ITS SUBSIDIARIES (“RENESAS”) PROVIDES TECHNICAL SPECIFICATIONS AND RELIABILITY DATA (INCLUDING DATASHEETS), DESIGN RESOURCES (INCLUDING REFERENCE DESIGNS), APPLICATION OR OTHER DESIGN ADVICE, WEB TOOLS, SAFETY INFORMATION, AND OTHER RESOURCES “AS IS” AND WITH ALL FAULTS, AND DISCLAIMS ALL WARRANTIES, EXPRESS OR IMPLIED, INCLUDING, WITHOUT LIMITATION, ANY IMPLIED WARRANTIES OF MERCHANTABILITY, FITNESS FOR A PARTICULAR PURPOSE, OR NON-INFRINGEMENT OF THIRD-PARTY INTELLECTUAL PROPERTY RIGHTS.

These resources are intended for developers who are designing with Renesas products. You are solely responsible for (1) selecting the appropriate products for your application, (2) designing, validating, and testing your application, and (3) ensuring your application meets applicable standards, and any other safety, security, or other requirements. These resources are subject to change without notice. Renesas grants you permission to use these resources only to develop an application that uses Renesas products. Other reproduction or use of these resources is strictly prohibited. No license is granted to any other Renesas intellectual property or to any third-party intellectual property. Renesas disclaims responsibility for, and you will fully indemnify Renesas and its representatives against, any claims, damages, costs, losses, or liabilities arising from your use of these resources. Renesas' products are provided only subject to Renesas' Terms and Conditions of Sale or other applicable terms agreed to in writing. No use of any Renesas resources expands or otherwise alters any applicable warranties or warranty disclaimers for these products.

(Disclaimer Rev.1.01)

Corporate Headquarters

TOYOSU FORESIA, 3-2-24 Toyosu,
Koto-ku, Tokyo 135-0061, Japan
www.renesas.com

Trademarks

Renesas and the Renesas logo are trademarks of Renesas Electronics Corporation. All trademarks and registered trademarks are the property of their respective owners.

Contact Information

For further information on a product, technology, the most up-to-date version of a document, or your nearest sales office, please visit www.renesas.com/contact-us/.