

Internal Temperature Sensor Interface SLG47011

The application note gives step-by-step guidelines for creating a Compensated Internal Temperature Sensor Interface design using the SLG47011. Utilizing a unique set of features, particularly the ADC, MathCore, Memory Table, Data Buffers, and additional internal logic, the SLG47011 is used to achieve the best precision possible for this analog interface. The application note contains a complete schematic of an analog front end for an internal temperature sensor with noise canceling and offset compensation.

The application note comes complete with design files which can be found in the Reference section.

Contents

1. Terms and Definitions	2
2. References.....	2
3. Introduction	3
4. Interfacing the SLG47011 Internal Temperature Sensor	3
5. Sensor output correction.....	5
6. Operating Principle.....	7
7. AnalogPAK Design	8
8. Test Results.....	10
9. Conclusion	12
10. Revision History	13

1. Terms and Definitions

DFF	D Flip-Flop
GBWP	Gain Bandwidth Product
LUT	Look-up Table
MF	Multi-Function
OSC	Oscillator
TS	Temperature Sensor
VTS	Output Voltage of Temperature Sensor

2. References

For related documents and software, please visit:

[AnalogPAK™ | Renesas](#)

Download our free Go Configure Software Hub [1] to open the design file [2] and view the proposed circuit design. Use the AnalogPAK development tools to freeze the design into your own customized IC in a matter of minutes. Renesas Electronics provides a complete library of application notes [4] featuring design examples, as well as explanations of features and blocks within the Renesas IC.

- [1] [Go Configure Software Hub](#), Software Download and User Guide, Renesas Electronics
- [2] [AN-CM-404 Internal Temperature Sensor Interface.aap](#), AnalogPAK Design File, Renesas Electronics
- [3] [AnalogPAK Development Tools](#), AnalogPAK Development Tools Webpage, Renesas Electronics
- [4] [Application Notes](#), GreenPAK Application Notes Webpage, Renesas Electronics

3. Introduction

In the following application note, the AnalogPAK SLG47011 is used to create a Compensated Internal Temperature Sensor Interface design. The SLG47011 has an Analog Temperature Sensor (TS) with an output voltage linearly proportional to the die temperature (in Celsius, °C). The TS output is selected as the source for the ADC. The TS is rated to operate over a -40 °C to 85 °C temperature range.

4. Interfacing the SLG47011 Internal Temperature Sensor

The resulting voltage that the Internal Temperature Sensor gives corresponds to the specific temperature. The ADC converts this voltage to a 14-bit code using the formula below which is then used as an address for the Memory Table.

$$TS_{dec} = \frac{V_{TS} \cdot 16384}{1620},$$

where:

- V_{TS} (mV) is the TS Output Voltage,
- 16384 is the equivalent of 2^{14} ,
- 1620 is the internal Vref in mV,
- TS_{dec} is V_{TS} in 14-bit decimal format.

The ADC output will be used as a Memory Table address which is a 12-bit address. Therefore, all 14-bit calculations will be converted to a 12-bit format.

Using an approximated dependency of the temperature sensor output voltage as a function of temperature, it is possible to determine the temperature values at each voltage with a 1-bit step.

$$V_{TS} = 753.8 - 1.83 \times T,$$

where

- V_{TS} (mV) is the TS Output Voltage,
- T (°C) is the Temperature.

This linear formula gives a slight error since the temperature sensor output is nonlinear. This means that the measured characterization data and the calculation of the average temperature sensor output for each temperature are used. These steps help to increase the precision of the results allowing compensation for the nonlinearity of the sensor output characteristic. [Table 1](#) shows the Temperature vs. TS Output ratios at temperatures from -40 °C to +85 °C with a 10 °C step. These voltage values are converted to a 12-bit code.

Table 1. Temperature vs TS Output Voltage

T, °C	Calculated VTS, mV	Measured statistical data VTS, mV	12-bit code, dec
-40	827.0	825.2	2086
-30	808,7	807.3	2041
-20	790,4	789,3	1996
-10	772,1	771.3	1950
0	753,8	753.3	1905
10	735,5	735.3	1859
20	717,2	717.5	1814
25	708,1	708.3	1791
30	698,9	698.3	1766
40	680,6	679.8	1719
50	662,3	661.6	1673
60	644,0	643.3	1627
70	625,7	624.8	1580
80	607,4	606.4	1533
85	598,3	596.6	1508

Using some approximation and forecast equations between each two temperature values, it's possible to find temperature values at voltages with a 1-bit resolution.

Since the values in the Data Buffers can only be positive integers, it is proposed to add a constant K = 40 to the temperature values and then multiply them by 10. This will enable the data output to be valid down to -40 °C. To determine the final temperature, the following formula is used:

$$T = \text{Reg (Data_Buffer1_Result)} / 10 - 40$$

Example:

VTS, mV	12-bit code, dec	Reg (Data_Buffer1_Result) (T + 40) * 10, °C	Resulting T, °C
717.5	1814	600	20

After determining all of the TS output voltage codes and their corresponding converted temperatures, the Memory Table is filled in such a way that the TS output voltage 12-bit code is equivalent to an address, and the corresponding converted temperature represents the word value. Thus, when the Memory Table input address is 1814, the output is 600, meaning +20 °C.

5. Sensor Output Correction

All chips are trimmed and have two predetermined temperature values stored in the registers during the production phase – external and internal temperature readings. The external temperature is measured with a 0.1 °C precision external temperature sensor and its result is saved in bytes [152:151]. The internal temperature is measured by the internal ADC and its result is saved in bytes [154:153]. Determination of the difference between these two temperatures is done by the MathCore and gives the offset value that should be added or subtracted from the measured value to achieve the best internal temperature performance.

The procedure of offset compensation is as follows:

1. Open a SLG47011 project in the GreenPAK Designer software (see [1] above).
2. Connect an SLG47011 chip.

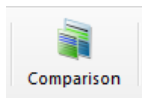

3. Open the Comparison tool.
4. Select “Chip Project” as Source 2. The program will automatically find a connected board. Click “Read”.

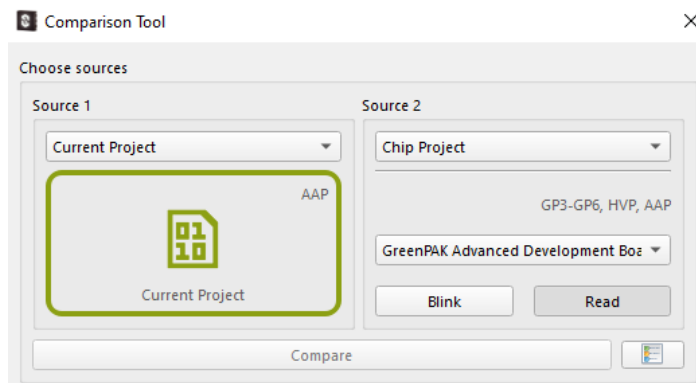

5. Check bytes [152:151] for the external temperature value and bytes [154:153] for the internal temperature.

Byte	Register	Current Project	Chip Project
0x151	2696	0	0
	2697	0	0
	2698	0	0
	2699	0	0
	2700	0	0
	2701	0	1
	2702	0	0
0x152	2703	0	0
	2704	0	0
	2705	0	0
	2706	0	1
	2707	0	0
	2708	0	0
	2709	0	1
0x153	2710	0	0
	2711	0	0
	2712	0	0
	2713	0	0
	2714	0	1
	2715	0	1
	2716	0	1
0x154	2717	0	0
	2718	0	0
	2719	0	0
	2720	0	1
	2721	0	1
	2722	0	1
	2723	0	1
2724	0	0	
2725	0	0	
2726	0	0	
2727	0	0	

- Convert these values to 14-bit decimal numbers. Convert these numbers to the temperature using the formula:

$$\text{External temperature: } T_{\text{ext}} = 50 \times V_{\text{ext}}^{\text{dec}} / 16384$$

$$\text{Internal temperature: } T_{\text{int}} = - (1620 \times V_{\text{int}}^{\text{dec}} / 16384 - 753.8) / 1.83$$

- Convert the internal temperature value T_{int} to a 12-bit decimal number and use [Table 1](#) to find the temperature that corresponds to T_{int} . If there is no T_{int} value in [Table 1](#), use the two nearest temperature points to approximate the line.
- Find the difference between the external temperature and approximated internal temperature.
- Multiply this difference by 10 and round the value. This offset value will be added to the ADC result by the MathCore.
- Assign the found offset value to the constant B value in the MathCore Properties.
- If the difference of the numbers in step 8 is positive, set the MathCore Adder/Subtractor enable setting to "Adder". If the difference of the numbers in step 8 is negative, change the MathCore Adder/Subtractor enable setting to "Subtractor".

6. Operating Principle

The Internal Temperature Sensor Interface Simplified Block Diagram is shown in [Figure 1](#).

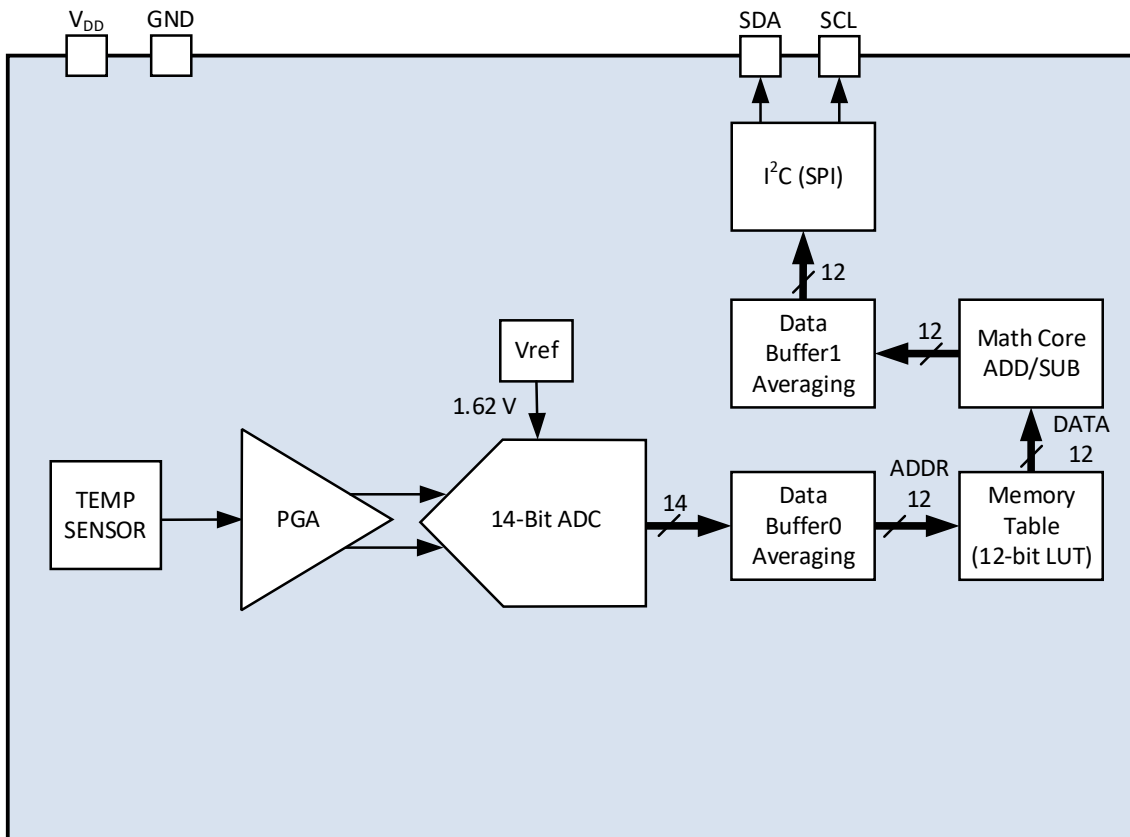

Figure 1. Internal Temperature Sensor Simplified Block Diagram

The Memory Table macrocell is filled with the average voltage-temperature dependence converted to 12-bit format so that the word address corresponds to the appropriate temperature value.

The Temp Sensor must be connected to the PGA with 1x gain in single-ended input mode. The ADC samples the measured value and sends its output to Data Buffer 0 for noise filtering. This data is then used as an address in the Memory Table.

Now that the temperature value is obtained it can be compensated in the MathCore. The MathCore formula is $kx + b$, where x is the temperature before compensation, $k = 1$, and b is the offset between the measured and ideal trimming temperatures. Please note that all values in the MathCore and Memory table are multiplied by 10 to result in integers. Thus, the offset of 0.7 °C is equal to the coefficient b of 7 in the MathCore.

After compensation, the data is sent to Data Buffer1 for the final noise-canceling stage.

7. AnalogPAK Design

The AnalogPAK Design is shown in Figure 2.

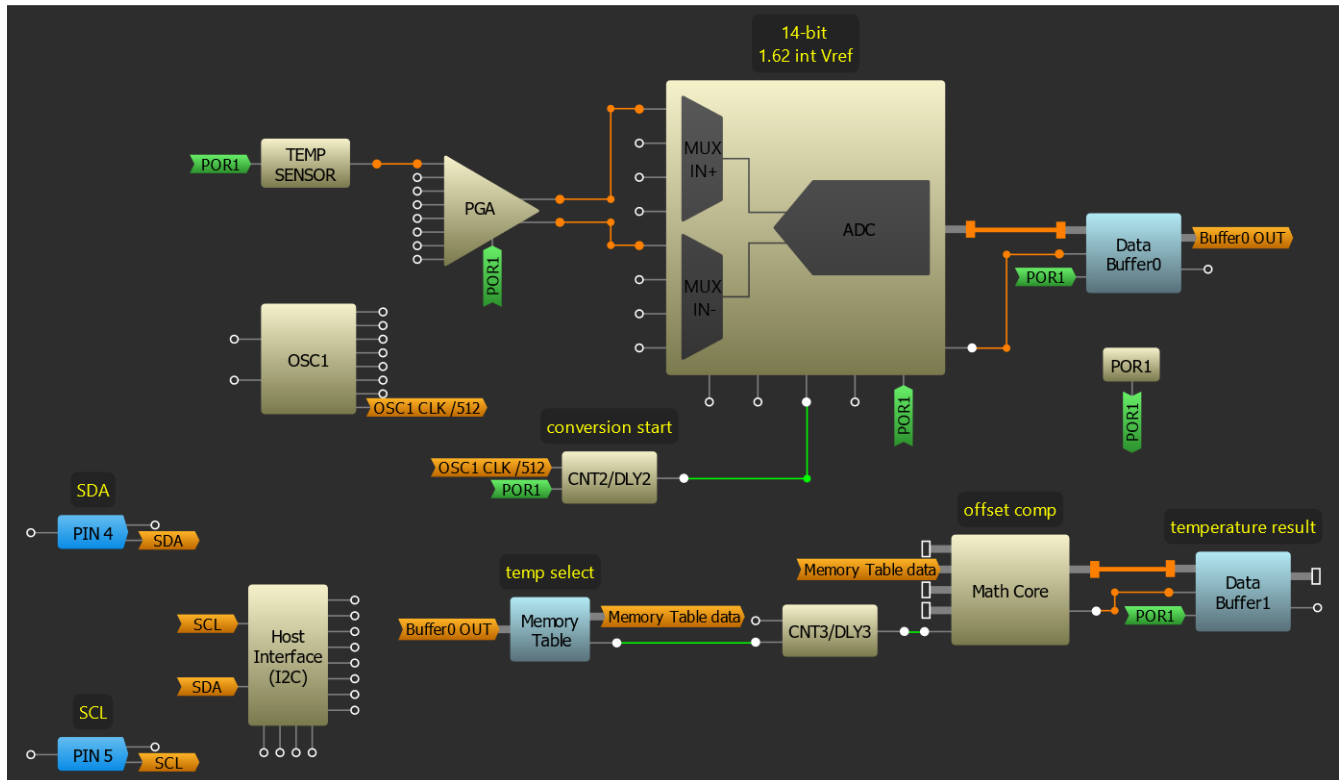

Figure 2. Internal Temperature Sensor AnalogPAK Design

CNT2/DLY2 is used to properly turn on the ADC after the first turn-on when the POR arrives, as well as in further operations when the ADC needs to be turned on and off.

The signal from the Temperature sensor arrives at the single-ended IN+ input of PGA Channel 0. This channel is used for temperature measurement. The ADC samples this data and sends it to Data Buffer0.

The ADC has a 14-bit resolution, 1.62 V of internal Vref, and has a sampling rate of 62.5 ksp/s. The ADC's 14-bit resolution with the following conversion to 12-bit ensures a higher precision than initial measurements made in 12-bit resolution.

Data Buffer0 works in Moving Average mode with 8 words length forming the first noise canceling stage. Then, this data is used as a 12-bit Memory Table address. The Memory Table is filled in such a way that the word address is equivalent to the measured voltage of the Temperature Sensor and corresponds to the appropriate temperature at this voltage. The Memory Table works in ADDR-to-DATA mode.

The memory truncation is set to the middle 12 bits (of 16 total), meaning that the [b13:b2] bits from Data Buffer 0 are selected as the Memory Table address [m11:m0]. Thus, the MSB part is sent from the 14-bit ADC to the 12-bit Memory Table (Figure 3).

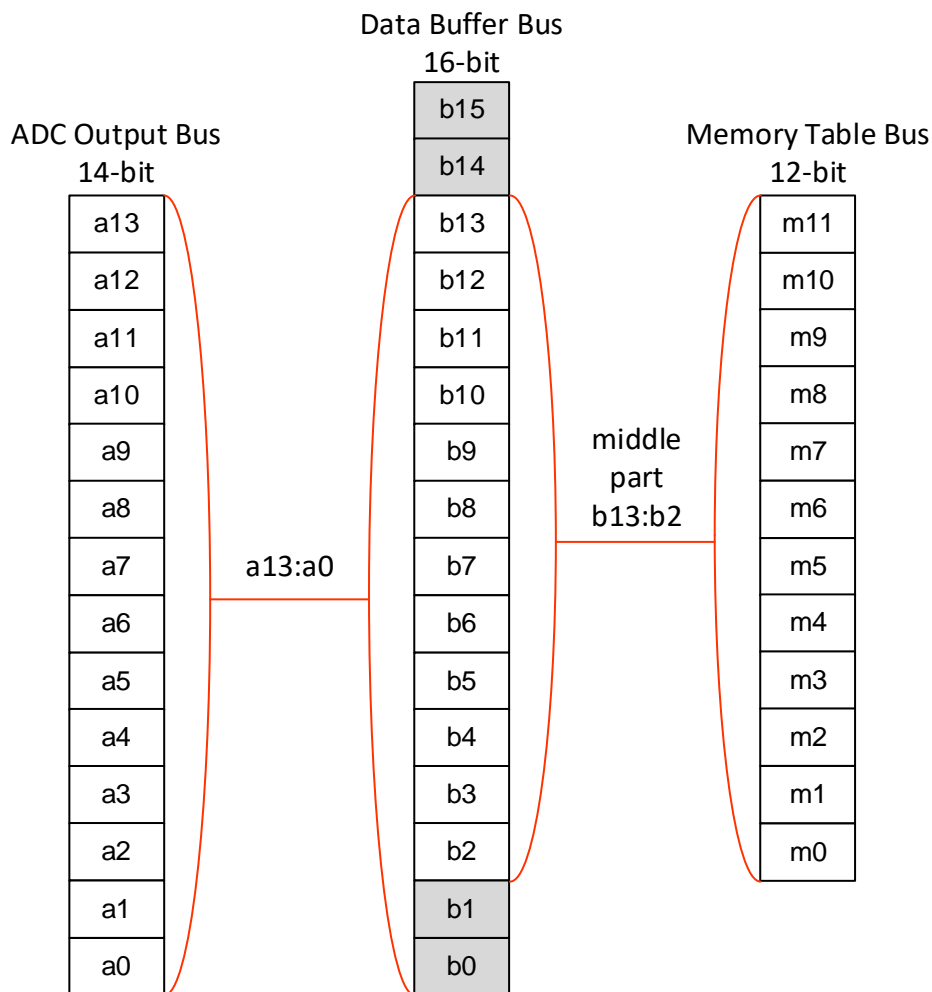

Figure 3. Data Flow and Alignment

After selecting the required temperature in the Memory Table, this temperature data goes to the Math Core for Offset Compensation. The MathCore formula is $kx + b$, where x is the temperature before compensation, $k = 1$, and b is the offset between the measured and ideal trimming temperatures. Please note that all values in the MathCore and Memory table are multiplied by 10 so that they will be integers. Thus, the offset of 0.7 °C is equal to the coefficient b of 7 in the MathCore.

After compensation, the data goes to Data Buffer1 for the final noise-canceling stage and can be read via I²C.

The I²C Virtual Inputs software window allows the user to read the data from the Data Buffer0 and Data Buffer1 outputs in real time:

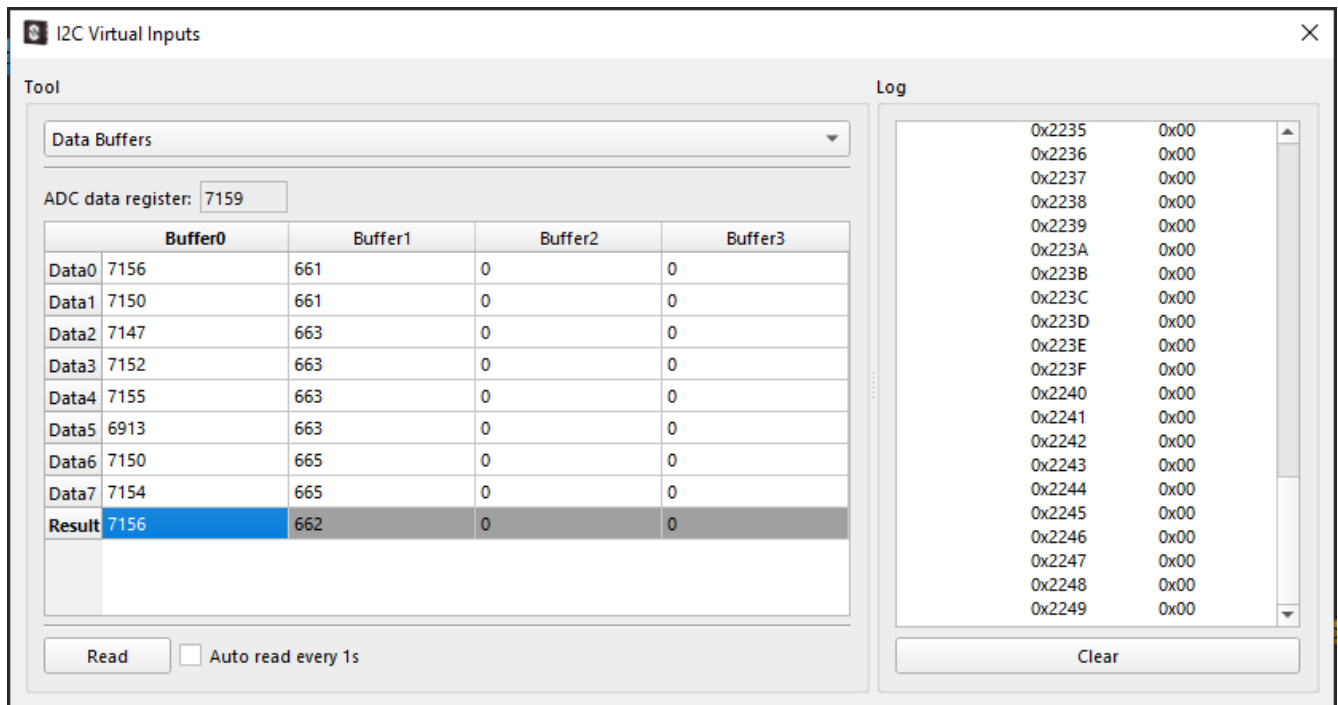

Figure 4. Data Buffers Values

The Data Buffer1 output is the final result, which now should be converted to the temperature by dividing it by 10 and subtracting 40.

$$T = \text{Data_Buffer1} / 10 - 40$$

8. Test Results

The proposed design was tested on 30 chips for temperatures from -40 °C to +85 °C. The measurements were done using precision 0.1 °C accuracy equipment. The temperature sensor error before (Figure 5) and after (Figure 6) compensation is calculated using the interquartile range method.

In descriptive statistics, the interquartile range (IQR) is a measure of statistical dispersion, which is the spread of the data. The interquartile range (IQR), also called the midspread, is the difference between the 75th (Q3) and 25th (Q1) percentiles of the data. It helps detect outliers, defined as values below $Q1 - 1.5 \text{ IQR}$ (LQ) or above $Q3 + 1.5 \text{ IQR}$ (HQ). Typically, 99.7% of data falls within this range. The graphs below show these LQ and HQ values as well as the median error.



Figure 5. Temperature Sensor Error before Compensation

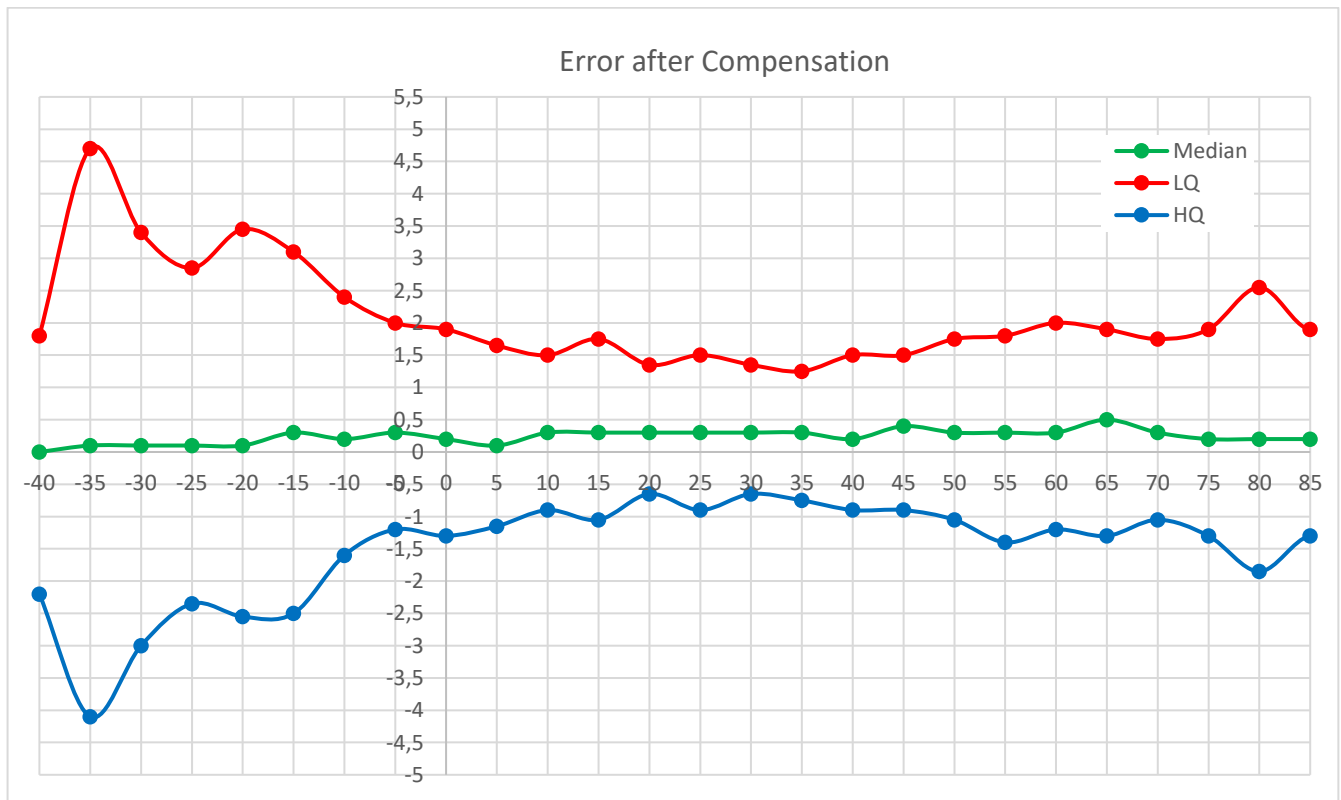

Figure 6. Temperature Sensor Error after Compensation

As can be seen, after compensation, the median value of the error in the entire range does not exceed 0.5 °C, while before compensation, this error is in the range of 1.5 °C – 2.0 °C from -45 °C to +45 °C and decreases until the end of the temperature range at +85 °C.

Talking about the range from LQ to HQ from 0 °C to +85 °C, the total error before compensation is from -2 °C to + 4.25 °C. After compensation, the situation improves significantly, and now the error is in the range of -1.75 °C to 2.5 °C.

In the range from -45 °C to 0 °C, the error before compensation is in the range from -1.5 °C to +5.5 °C. After compensation, the error is from -4 °C to +4.75 °C. There is an improvement, but at some points, such as in the case of -35 °C, negative changes are observed.

9. Conclusion

This application note gives step-by-step guidelines for creating an Internal Temperature Sensor Interface design using the SLG47011. Taking advantage of the unique set of features such as the ADC, Memory Table, MathCore, Data Buffers, and additional internal logic, the SLG47011 is used to achieve the best precision possible for this analog interface. The application note also includes a complete schematic of an analog front-end for an internal temperature sensor with offset compensation and noise cancelling.

The design was tested on 30 chips. The results show that the median sensor error decreased from 1.0 °C - 1.5 °C before compensation to 0.5 °C after compensation and became more linear and predictable. In the range from LQ to HQ from 0 °C to +85 °C, the total error before compensation is from -2 °C to + 4.25 °C. After compensation, the error is in the range of -1.75 °C to 2.5 °C. In the range from -45 °C to 0 °C, the total error before compensation is in the range from -1.5 °C to +5.5 °C. After compensation, the error is from -4 °C to +4.75 °C. For this range, it is recommended to review the values of the compensation coefficients.

10. Revision History

Revision	Date	Description
1.00	Nov 6, 2024	Initial release.

IMPORTANT NOTICE AND DISCLAIMER

RENESAS ELECTRONICS CORPORATION AND ITS SUBSIDIARIES (“RENESAS”) PROVIDES TECHNICAL SPECIFICATIONS AND RELIABILITY DATA (INCLUDING DATASHEETS), DESIGN RESOURCES (INCLUDING REFERENCE DESIGNS), APPLICATION OR OTHER DESIGN ADVICE, WEB TOOLS, SAFETY INFORMATION, AND OTHER RESOURCES “AS IS” AND WITH ALL FAULTS, AND DISCLAIMS ALL WARRANTIES, EXPRESS OR IMPLIED, INCLUDING, WITHOUT LIMITATION, ANY IMPLIED WARRANTIES OF MERCHANTABILITY, FITNESS FOR A PARTICULAR PURPOSE, OR NON-INFRINGEMENT OF THIRD-PARTY INTELLECTUAL PROPERTY RIGHTS.

These resources are intended for developers who are designing with Renesas products. You are solely responsible for (1) selecting the appropriate products for your application, (2) designing, validating, and testing your application, and (3) ensuring your application meets applicable standards, and any other safety, security, or other requirements. These resources are subject to change without notice. Renesas grants you permission to use these resources only to develop an application that uses Renesas products. Other reproduction or use of these resources is strictly prohibited. No license is granted to any other Renesas intellectual property or to any third-party intellectual property. Renesas disclaims responsibility for, and you will fully indemnify Renesas and its representatives against, any claims, damages, costs, losses, or liabilities arising from your use of these resources. Renesas' products are provided only subject to Renesas' Terms and Conditions of Sale or other applicable terms agreed to in writing. No use of any Renesas resources expands or otherwise alters any applicable warranties or warranty disclaimers for these products.

(Disclaimer Rev.1.01)

Corporate Headquarters

TOYOSU FORESIA, 3-2-24 Toyosu,
Koto-ku, Tokyo 135-0061, Japan
www.renesas.com

Trademarks

Renesas and the Renesas logo are trademarks of Renesas Electronics Corporation. All trademarks and registered trademarks are the property of their respective owners.

Contact Information

For further information on a product, technology, the most up-to-date version of a document, or your nearest sales office, please visit www.renesas.com/contact-us/.