

**Introduction**

An acoustic relay can be used to control devices (light switcher, electric heater, air cooler etc.) in response to a sound, or series of sounds.

**How does it work?**

An acoustic relay changes its output state only after some predefined number of acoustic signals (in our case it is equal to 2 claps), which should come sequentially for some period of time. If number of claps is greater, less, or the pause between claps is greater than defined, the acoustic relay won't change its output state.

After a simple modification, this device can be used as an acoustic controller. It will monitor the number of acoustic signals and change its output state accordingly. For example, if one acoustic sound comes, a light will be turned on, if two – heater, if three – air conditioner. Illumination can be controlled in the room, air conditioner mode can be chosen, motor speed can be controlled, etc.

**System description**

This acoustic relay consists of a microphone, non-inverting amplifier, diode detector, low frequency filter, and analyzing circuit.

**Device operating principles**

A clap generates a short, large amplitude pulse on the microphone's output. It goes through the capacitor C1 to OPAMP (U1) input with variable amplifying coefficient (from 7.5 to 82, changed by R4) for the sensitivity setting. After amplifying, this pulse will be detected as illustrated in Figure 2.

It is recommended to use diodes with small forward drop voltage (germanium or Schottky diodes), to minimize sensitivity loss. After detection, the pulse will be filtered and sent to PIN10 of GreenPAK4 IC.

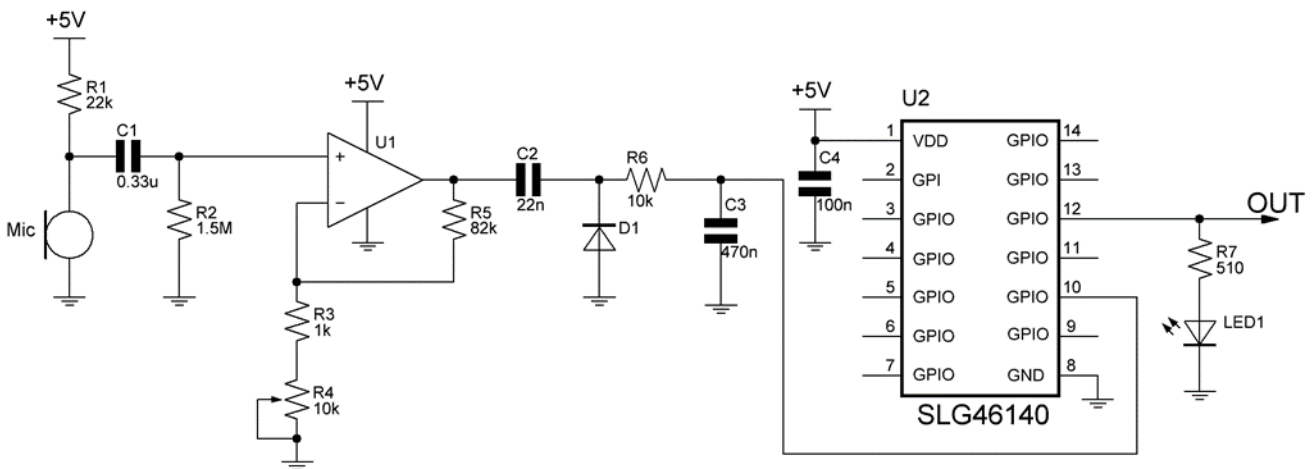

**Figure 1. Device circuit**

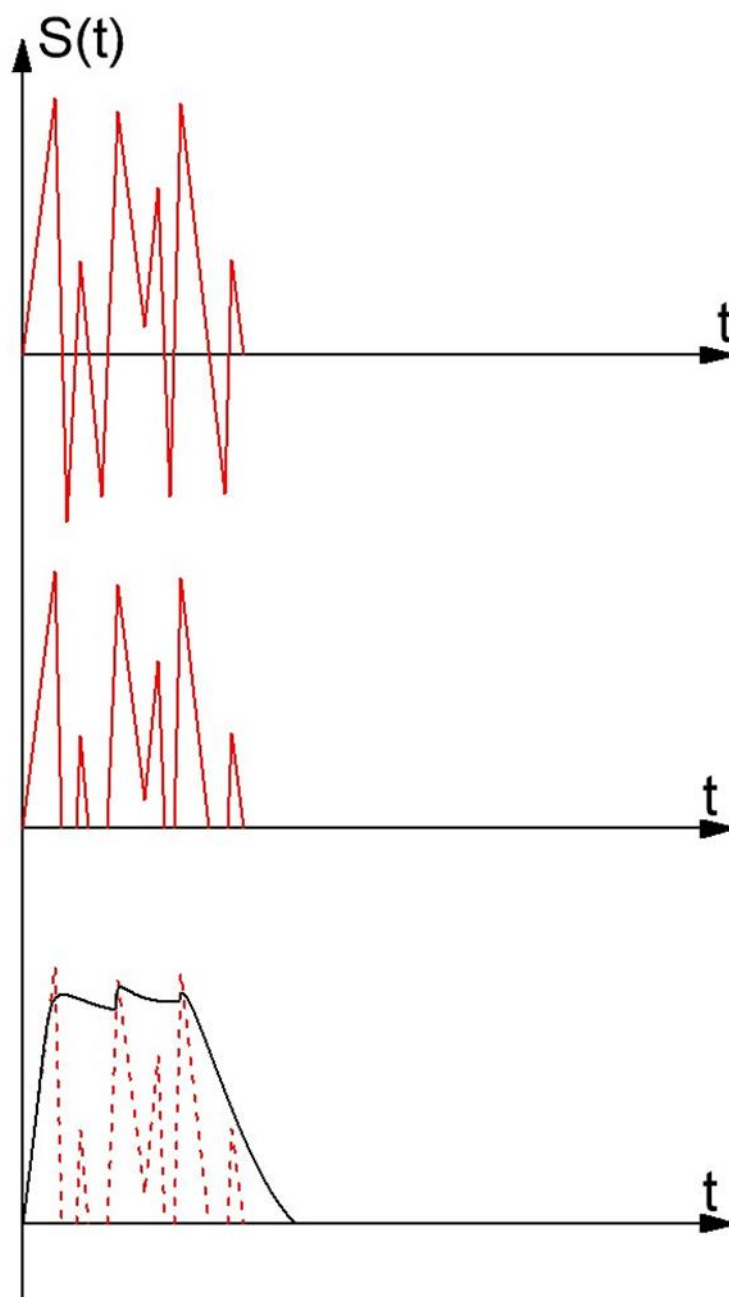

**Figure 2. Detection and filtration process**

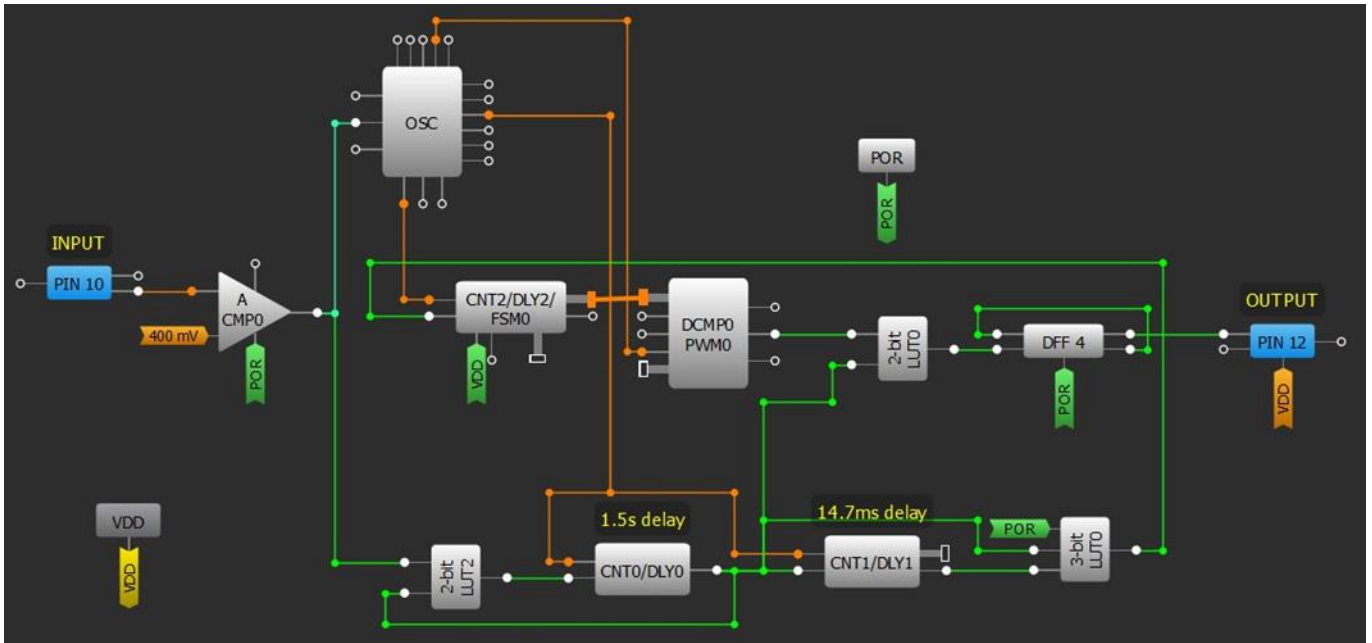

Figure 3. Design circuit

PIN 10 is configured as an analog input with 100K pull-down resistor for C3 capacitor discharge.

The pulse arrives at the ACMP0 input, where it will be compared with a 400mV reference voltage. ACMP0 hysteresis is enabled to prevent noise on the output.

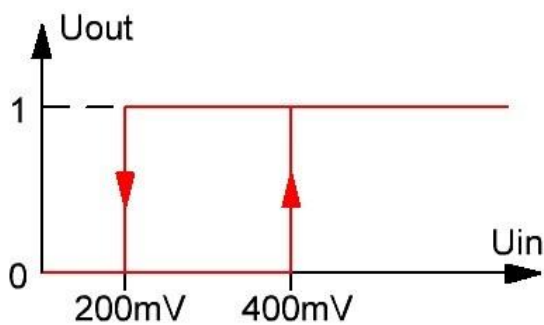

Figure 4. ACMP0 thresholds

Figure 5. ACMP0 properties

If the input pulse exceeds ACMP0 threshold, an output pulse appears, which goes to the CNT2 input. CNT2 (up counting) data buss is connected to DCMP0, which compares CNT2 counter data with register 0 (DCMP EQ output goes High when data are equal). Changing register 0 values, it is possible to control the desired number of claps. DCMP0 out is connected to 2-bit LUT0. The ACMP0 output pulse also goes to the delay circuit based on 2-bit LUT2 and DLY0, which creates a 1.5 sec pulse (regardless of incoming pulses at the same time) and blocks 2-bit LUT0. DCMP0 EQ signal doesn't arrive at the 2-bit LUT0 during DLY0 operation.

ACMP0 output pulse also goes to the delay circuit based on 2-bit LUT2 and DLY0, which creates a 1.5 sec pulse (regardless of incoming pulses at the same time) and blocks 2-bit LUT0. DCMP0 EQ signal doesn't arrive at the 2-bit LUT0 during DLY0 operation. If DCMP0 EQ is High, after DLY0 duration it will arrive at the 2-bit LUT0 and will change DFF4 state to inverse. If Low – nothing will be changed. DFF4 inverted output is connected to its D input, so DFF4 operates as a 1-bit counter. DFF4 nReset is connected to POR, which provides the reset when VDD is switched.

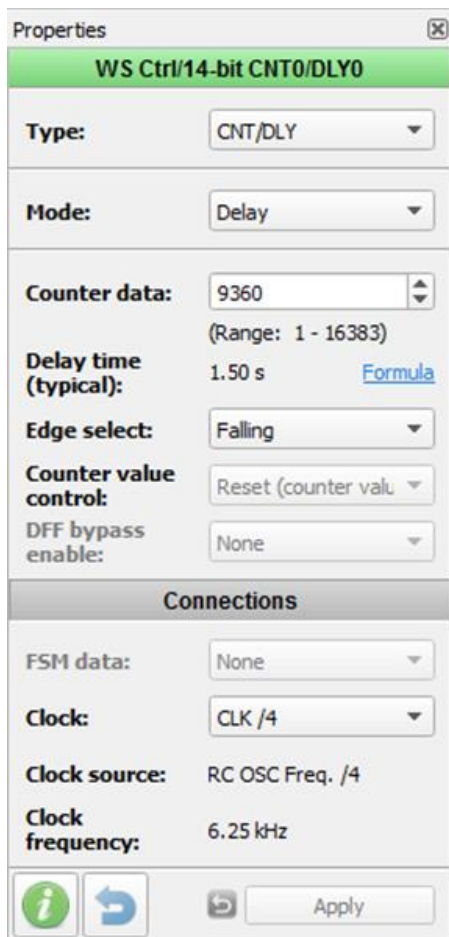

Figure 6. DLY0 properties

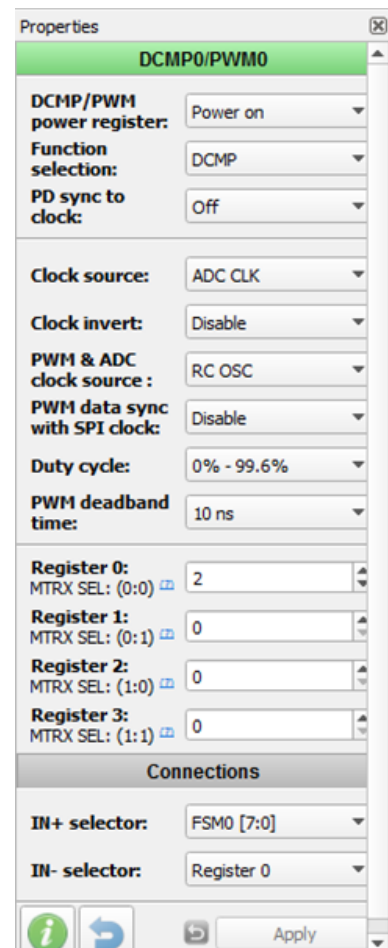

Figure 7. DCMP0 properties

2-bit LUT0				
IN3	IN2	IN1	IN0	OUT
0	0	0	0	0
0	0	0	1	0
0	0	1	0	1
0	0	1	1	0

Figure 8. 2-bit LUT0 and 2-bit LUT2 properties

3-bit LUT0				
IN3	IN2	IN1	IN0	OUT
0	0	0	0	1
0	0	0	1	1
0	0	1	0	1
0	0	1	1	1
0	1	0	0	0
0	1	0	1	1
0	1	1	0	0
0	1	1	1	0

Figure 9. 3-bit LUT0 properties

DLY1 and 3-bit LUT0 are used to make CNT2 reset on the falling edge of DLY0, or when VDD is taken off.

**Conclusion**

Using the SLG46140V allowed the following significant advantages:

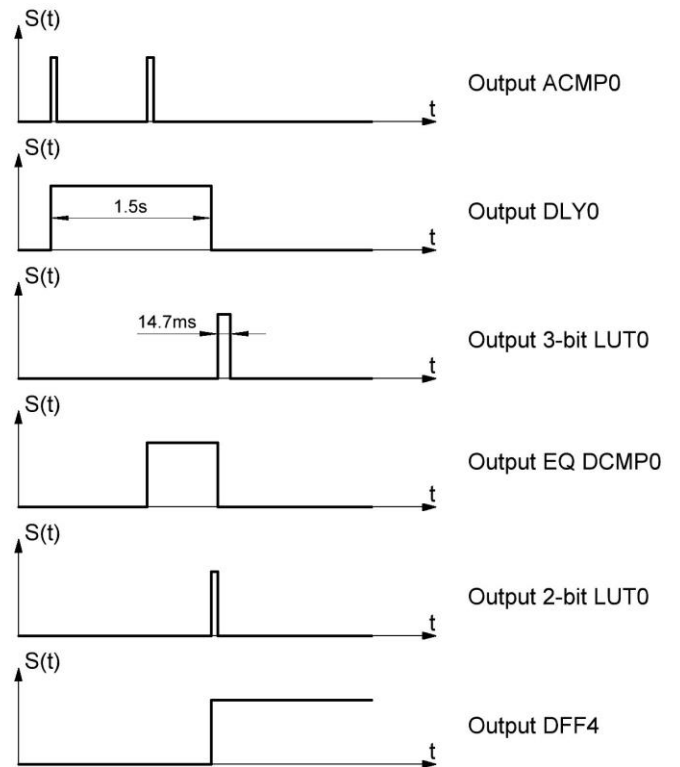

Figure 10. Design timing diagram

- Lower power consumption
- Smaller size (22 mm × 30 mm)
- Lower overall cost

Using the GreenPAK made the design of this acoustic relay easier and faster. Using this circuit one can create many other useful devices such as controllers for electric heaters, air coolers etc.

## IMPORTANT NOTICE AND DISCLAIMER

RENESAS ELECTRONICS CORPORATION AND ITS SUBSIDIARIES (“RENESAS”) PROVIDES TECHNICAL SPECIFICATIONS AND RELIABILITY DATA (INCLUDING DATASHEETS), DESIGN RESOURCES (INCLUDING REFERENCE DESIGNS), APPLICATION OR OTHER DESIGN ADVICE, WEB TOOLS, SAFETY INFORMATION, AND OTHER RESOURCES “AS IS” AND WITH ALL FAULTS, AND DISCLAIMS ALL WARRANTIES, EXPRESS OR IMPLIED, INCLUDING, WITHOUT LIMITATION, ANY IMPLIED WARRANTIES OF MERCHANTABILITY, FITNESS FOR A PARTICULAR PURPOSE, OR NON-INFRINGEMENT OF THIRD-PARTY INTELLECTUAL PROPERTY RIGHTS.

These resources are intended for developers who are designing with Renesas products. You are solely responsible for (1) selecting the appropriate products for your application, (2) designing, validating, and testing your application, and (3) ensuring your application meets applicable standards, and any other safety, security, or other requirements. These resources are subject to change without notice. Renesas grants you permission to use these resources only to develop an application that uses Renesas products. Other reproduction or use of these resources is strictly prohibited. No license is granted to any other Renesas intellectual property or to any third-party intellectual property. Renesas disclaims responsibility for, and you will fully indemnify Renesas and its representatives against, any claims, damages, costs, losses, or liabilities arising from your use of these resources. Renesas' products are provided only subject to Renesas' Terms and Conditions of Sale or other applicable terms agreed to in writing. No use of any Renesas resources expands or otherwise alters any applicable warranties or warranty disclaimers for these products.

(Disclaimer Rev.1.01)

### Corporate Headquarters

TOYOSU FORESIA, 3-2-24 Toyosu,  
Koto-ku, Tokyo 135-0061, Japan  
[www.renesas.com](http://www.renesas.com)

### Trademarks

Renesas and the Renesas logo are trademarks of Renesas Electronics Corporation. All trademarks and registered trademarks are the property of their respective owners.

### Contact Information

For further information on a product, technology, the most up-to-date version of a document, or your nearest sales office, please visit [www.renesas.com/contact-us/](http://www.renesas.com/contact-us/).