

## Introduction

The GreenPAK, can be configured to provide a flexible, low-power and cost-effective capacitive touch button solution. GreenPAK can implement system reset and touch function in the same device, with the benefit of extra GPIO, logic, and timing resources that can be used to implement other system functions.

## How It Works

The GreenPAK touch solutions use Projected Self Capacitance method. Using integrated mixed-signal components, GreenPAK compares the frequency passed through a reference circuit with that of the touch sensor.

As a finger approaches, the RC constant of the touch sensor changes, affecting the frequency passed through. Once a specified threshold is reached, GreenPAK recognizes the finger capacitance as valid button input. Using the internal RC oscillator, GreenPAK switches between wake and sleep states to conserve power.

The dual touch button design consists of three functional parts:

1. Wake and Sleep
2. Master and Slave Generator
3. Comparing and Signal Processing

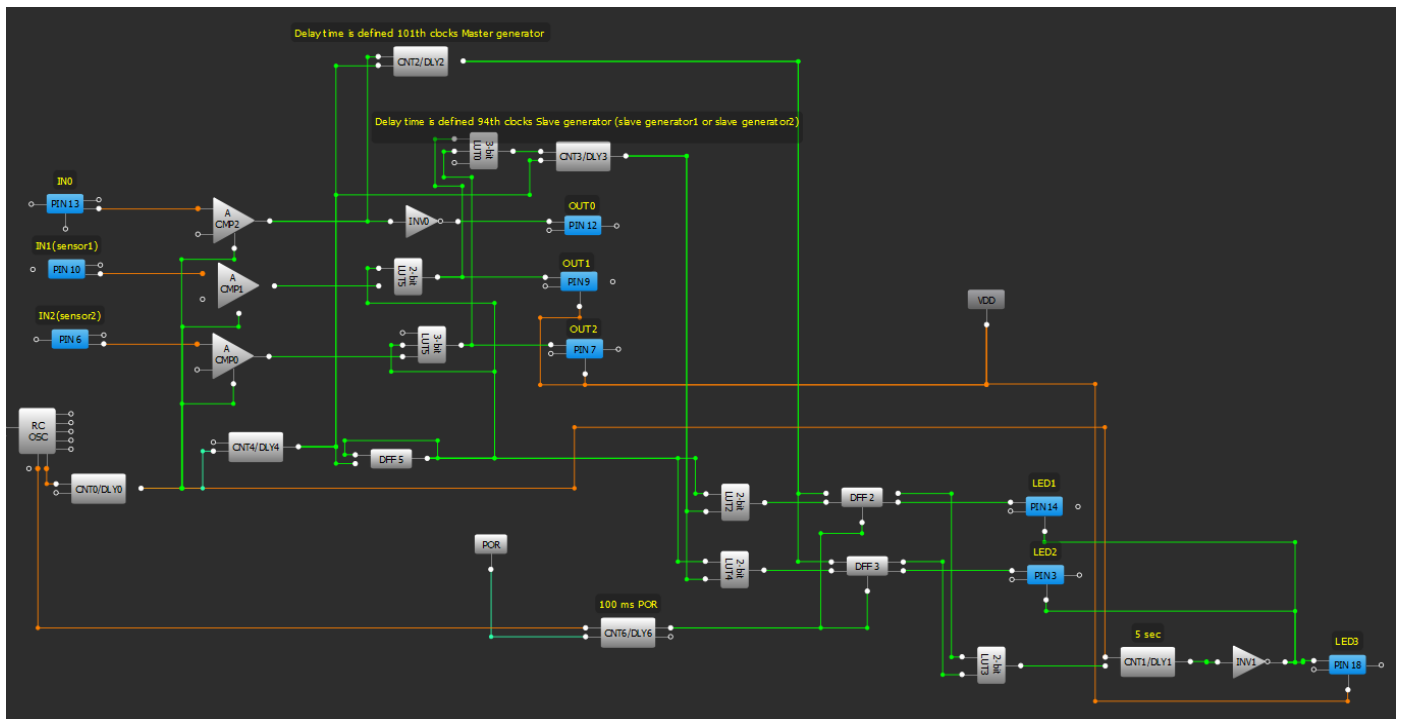

Figure 1. Touch button circuit schematic

### Wake and Sleep

The Wake and sleep circuit creates pulses with 28mS period and 2.5mS HIGH duration. This is made to reduce power consumption by ~10x. To prevent accidental waking, touches shorter than 56 mS will not be detected.

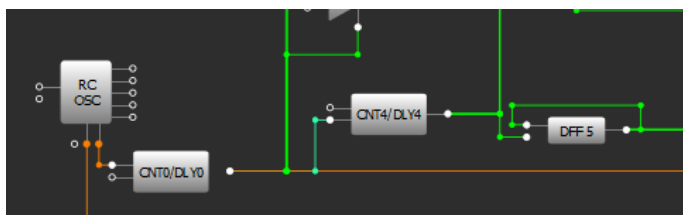

Figure 2. Wake and sleep circuit

### Master and Slave Generators

The generators have two inverters with external feedback that is connected to two metal plates.

Touching one of the metal plates increases the capacity in the feedback circuit, which causes the generated frequency to decrease. These generators are switched ON while the Wake and Sleep internal signal is HIGH.

### Comparing and Signal Processing

When the plate is touched, additional capacitance in the feedback circuit leads to a decrease of the generated frequency. Output of CNT0/DLY0 produces a pulse and starts the CNT2/DLY2 and CNT3/DLY3 operation with each having different clocking frequencies (Fclk). If the clocking frequencies are close or equal to each other, then the CNT3/DLY3 output pulse appears earlier than CNT2/DLY2 output. This timing will switch DFF3 or DFF2 output to LOW. If the frequencies differ more than ~5% (clock frequency for CNT3/DLY3 is less than clock frequency for CNT2/DLY2) then the DFF3 or DFF2 output switches to HIGH.

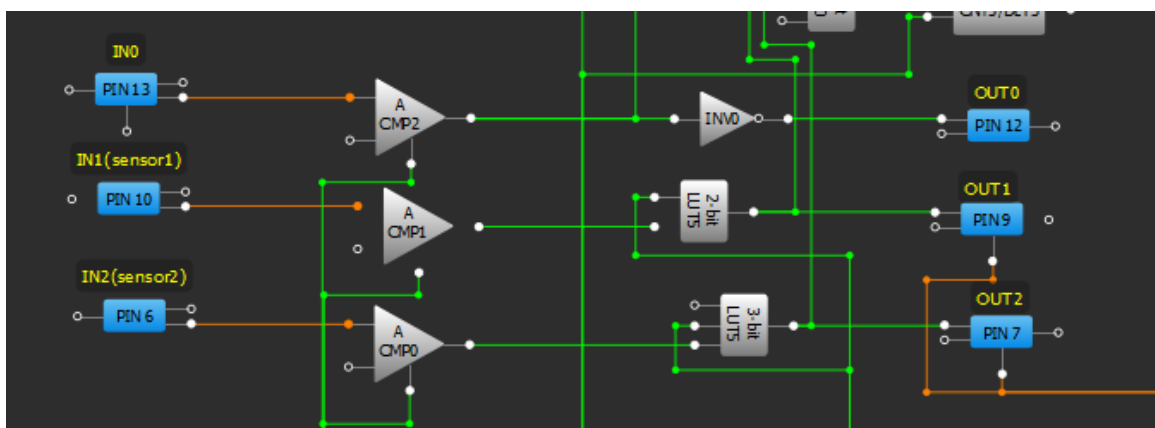
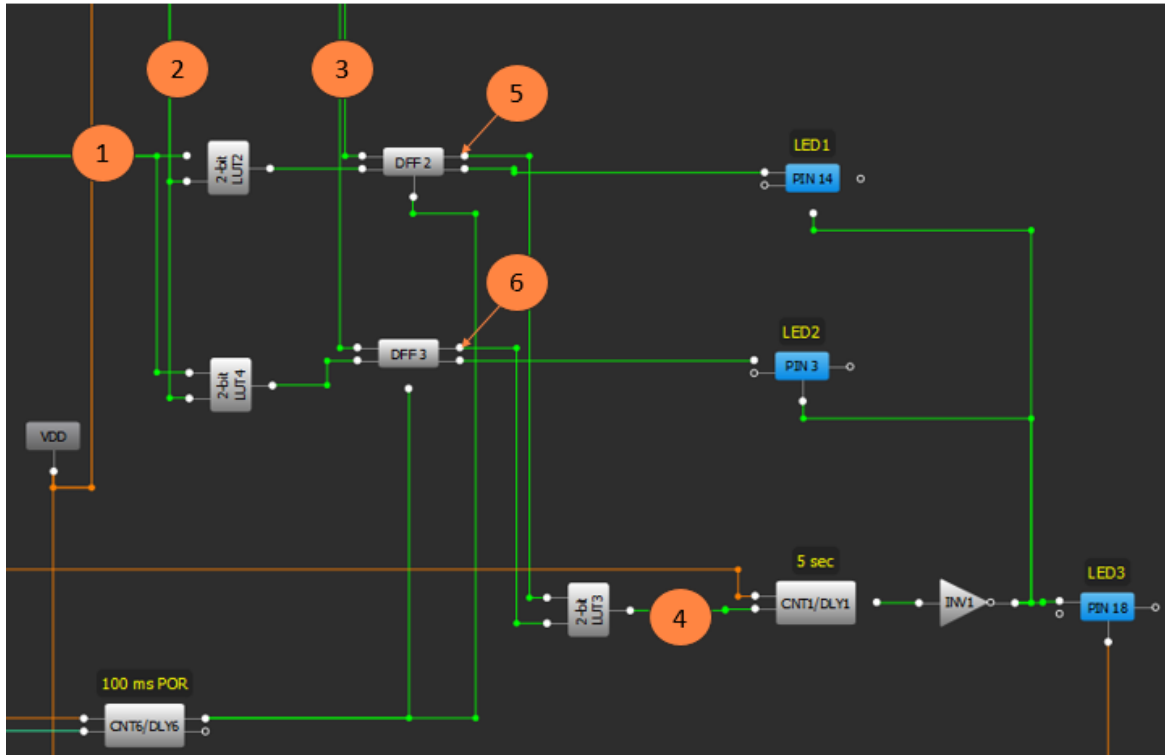

Figure 3. Touch plate input circuit



- ① selecting signal (if signal is HIGH then Button 1 is selected or if signal is LOW then Button 2 is selected)
- ② signal is CNT3/DLY3 overflow for Slave generator1 or 2 (if signal is HIGH then counter overflow)
- ③ signal is CNT2/DLY2 overflow for Master generator (if signal is HIGH then counter overflow)
- ④ if signal is High then both buttons are touched
- ⑤ if signal is High then Button1 are touched
- ⑥ if signal is High then Button2 are touched

Figure 4. Description for Fig. 5 timing diagram

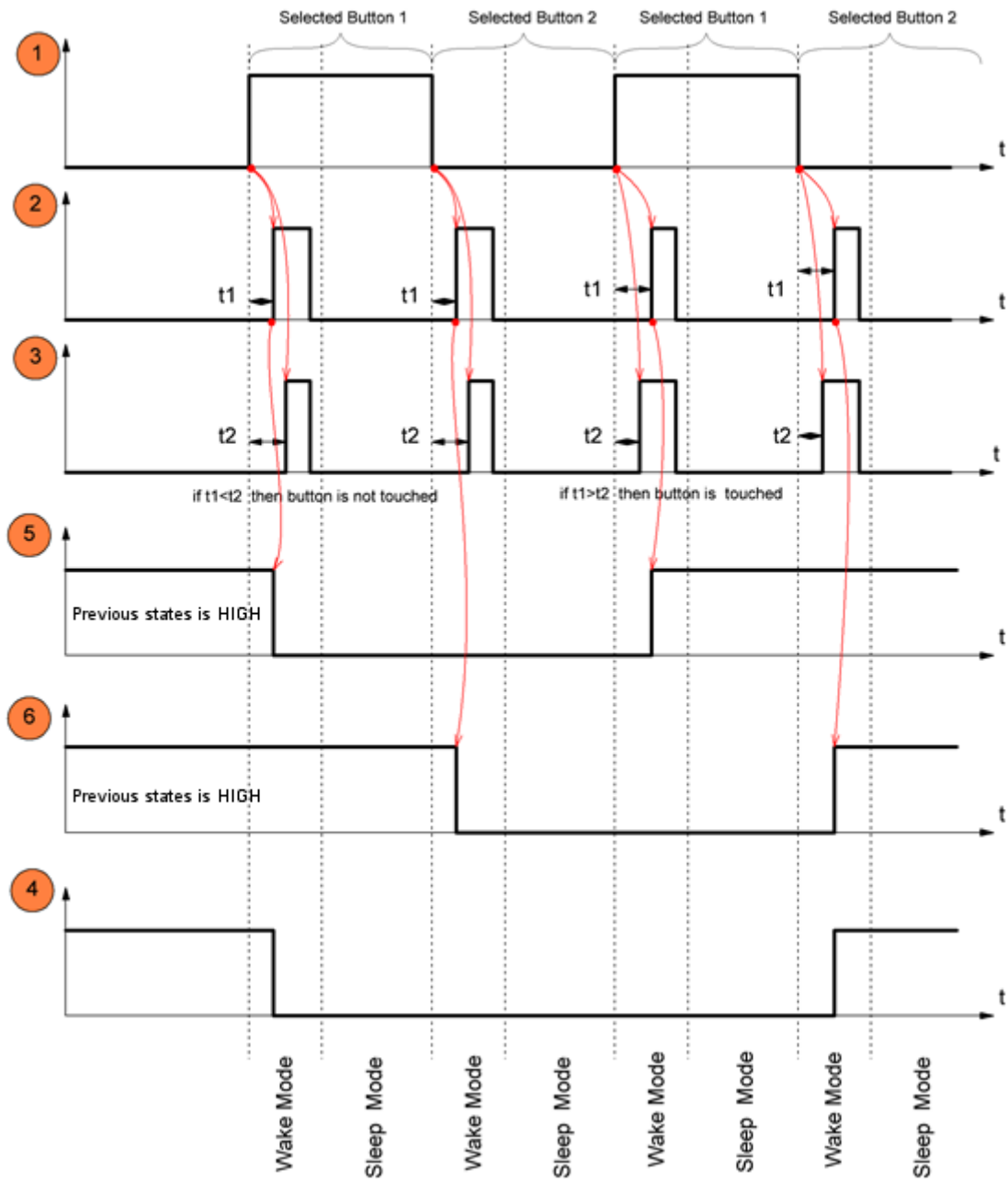

Figure 5. Touch sense timing diagram

### Single Button

The GreenPAK device (SLG46110V) is capable of implementing touch buttons and more. This device is designed for space saving or simpler applications.

### Features

- 1.6 x 1.6 mm **SLG46110V**
- 3 extra GPIO available
- Extra logic and timing resources
- NVM tunable sensitivity

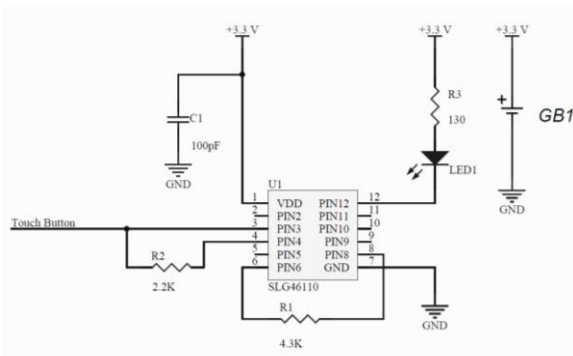

Figure 6. Single button schematic



Figure 7. Single button demo

### Dual Button Reset

A GreenPAK with more resources (SLG46721V) is capable of doing multiple touch buttons with additional functionality, such as RESET, while still reducing component cost and board space.

### Features

- 2.0 x 3.0 mm **SLG46721V**
- 9 extra GPIO available
- Extra logic and timing resources
- Independently NVM tunable sensitivity

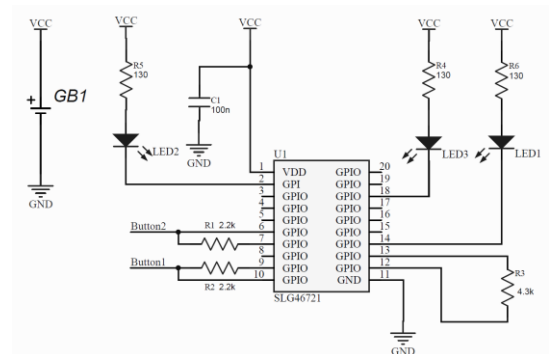

Figure 8. Dual button schematic

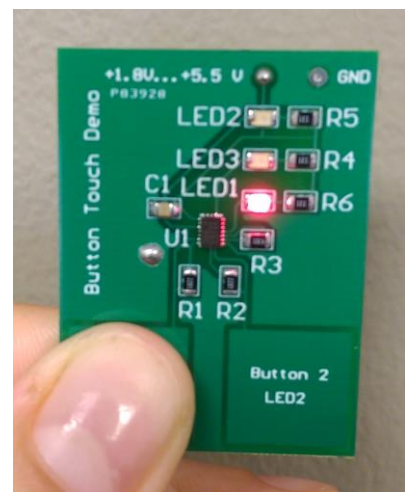

Figure 9. Dual button demo

### Adjustment sensitivity

There are two methods of sensitivity adjustment. The first method is an NVM tune. The second method is tuning by external resistor. For debugging of the device for small volume production, using a tuning external resistor is recommended. For large quantity mass production, the NVM tuning method is recommended.

---

### Conclusion

This application example will be useful for developing devices that use intelligent touch control interfaces. Capacitive touch control interface offers a number of advantages to the manufacturer and consumer alike, including:

- Replacing mechanical buttons and switches.
- Reducing overall system cost.
- Enhancing reliability by eliminating mechanical wear and tear.
- Providing greater flexibility for product designers.

## IMPORTANT NOTICE AND DISCLAIMER

RENESAS ELECTRONICS CORPORATION AND ITS SUBSIDIARIES (“RENESAS”) PROVIDES TECHNICAL SPECIFICATIONS AND RELIABILITY DATA (INCLUDING DATASHEETS), DESIGN RESOURCES (INCLUDING REFERENCE DESIGNS), APPLICATION OR OTHER DESIGN ADVICE, WEB TOOLS, SAFETY INFORMATION, AND OTHER RESOURCES “AS IS” AND WITH ALL FAULTS, AND DISCLAIMS ALL WARRANTIES, EXPRESS OR IMPLIED, INCLUDING, WITHOUT LIMITATION, ANY IMPLIED WARRANTIES OF MERCHANTABILITY, FITNESS FOR A PARTICULAR PURPOSE, OR NON-INFRINGEMENT OF THIRD-PARTY INTELLECTUAL PROPERTY RIGHTS.

These resources are intended for developers who are designing with Renesas products. You are solely responsible for (1) selecting the appropriate products for your application, (2) designing, validating, and testing your application, and (3) ensuring your application meets applicable standards, and any other safety, security, or other requirements. These resources are subject to change without notice. Renesas grants you permission to use these resources only to develop an application that uses Renesas products. Other reproduction or use of these resources is strictly prohibited. No license is granted to any other Renesas intellectual property or to any third-party intellectual property. Renesas disclaims responsibility for, and you will fully indemnify Renesas and its representatives against, any claims, damages, costs, losses, or liabilities arising from your use of these resources. Renesas' products are provided only subject to Renesas' Terms and Conditions of Sale or other applicable terms agreed to in writing. No use of any Renesas resources expands or otherwise alters any applicable warranties or warranty disclaimers for these products.

(Disclaimer Rev.1.01)

### Corporate Headquarters

TOYOSU FORESIA, 3-2-24 Toyosu,  
Koto-ku, Tokyo 135-0061, Japan  
[www.renesas.com](http://www.renesas.com)

### Trademarks

Renesas and the Renesas logo are trademarks of Renesas Electronics Corporation. All trademarks and registered trademarks are the property of their respective owners.

### Contact Information

For further information on a product, technology, the most up-to-date version of a document, or your nearest sales office, please visit [www.renesas.com/contact-us/](http://www.renesas.com/contact-us/).