



User's Manual

V850 WebServer

**Embedded Web Server Technology
Demonstration Kit**

Hardware

Document No. U15887EE1V0UM00
Date published: October 2001

© NEC Corporation 2001
© I2SE GmbH 2001
Printed in Germany

Table of Contents

1. Introduction	4
1.1. Embedded Systems and the Internet	4
1.2. Remote Access Applications	4
1.3. Embedded Web Server	4
2. Product Overview.....	5
2.1. Product Function.....	5
2.2. Construction.....	5
3. Product Properties	6
3.1. Block Diagram.....	6
3.1.1. Main Board	6
3.1.2. Microcontroller Unit.....	7
3.2. Description Of The Main Board	8
3.2.1. Drawing.....	8
3.2.2. Power Supply.....	9
3.2.3. Socket For The Microcontroller Unit	9
3.2.4. Socket For The MCCS Modules.....	10
3.2.5. Digital Circuit.....	11
3.2.5.1. Schematic	11
3.2.5.2. Input Function	11
3.2.5.3. Output Function	11
3.2.6. Analog Circuit	12
3.2.6.1. Schematic.....	12
3.2.6.2. Analog Input Function.....	12
3.2.6.3. Input Function	12
3.2.7. RS232 Interfaces	13
3.2.7.1. DCE Interface	13
3.2.7.2. DTE Interface.....	13
3.2.8. Expansion Connectors	14
3.2.8.1. External Memory Expansion.....	14
3.2.8.2. Port Expansion	14
3.3. Description Of The Microcontroller Unit.....	15
3.3.1. Drawing.....	15
3.3.2. Power Supply.....	15
3.3.3. Microcontroller	16
3.3.3.1. Features.....	16
3.3.3.2. Pin Assignment.....	16
3.3.3.3. Operating Modes	19
3.3.4. Flash Programming Interface	19
3.3.5. External Data Memory	19
3.3.6. Ethernet Interface	19
3.3.7. Expansion Connectors	20
3.3.8. Additional	20
3.4. Connectors.....	21
3.4.1. Main Board	21
3.4.1.1. Memory Expansion for Microcontroller Unit	21
3.4.1.2. Port Expansion for Microcontroller Unit.....	22
3.4.1.3. Memory Expansion for MCCS Modules	23
3.4.1.4. Port Expansion for MCCS Modules.....	24
3.4.1.5. Memory Expansion for User Applications	25
3.4.1.6. Port Expansion for User Applications.....	26
3.4.1.7. Serial DTE- Interface (For User Device)	27
3.4.1.8. Serial DCE- Interface (For External Modem)	27
3.4.1.9. Power Supply.....	27

3.4.2.	Microcontroller Unit.....	28
3.4.2.1.	Memory Expansion.....	28
3.4.2.2.	Port Expansion	29
3.4.2.3.	Ethernet Interface	30
3.4.2.4.	Flash Programming Interface	30
4.	Product Specification	31
4.1.	Mechanical and Climatic Requirements	31
4.2.	Electrical Requirements	31
4.2.1.	Main Board	31
4.2.1.1.	Memory Expansion for Microcontroller Unit	31
4.2.1.2.	Port Expansion for Microcontroller Unit.....	31
4.2.1.3.	Memory Expansion for MCCS Modules	31
4.2.1.4.	Port Expansion for MCCS Modules.....	31
4.2.1.5.	Memory Expansion for User Applications	31
4.2.1.6.	Port Expansion for User Applications.....	32
4.2.1.7.	Serial DTE- Interface (For User Device)	32
4.2.1.8.	Serial DCE- Interface (For External Modem)	32
4.2.1.9.	Power Supply.....	32
4.2.2.	Microcontroller Unit.....	32
4.2.2.1.	Memory Expansion.....	32
4.2.2.2.	Port Expansion	32
4.2.2.3.	Ethernet Interface	32
4.2.2.4.	Flash Programming Interface	32
4.3.	Contents.....	32

1. Introduction

1.1. Embedded Systems and the Internet

In recent years the Internet has become a more and more important instrument for communication. It is built on standard protocols defined over the last 30 years, so that now any computer can be connected to the World Wide Web.

Currently most computers with Internet access are PCs running large operating systems. Now, however, with the entry of embedded systems into the Internet world, there has become a definite requirement for solutions without the traditional overheads of PC connectivity.

1.2. Remote Access Applications

Internet connected embedded systems have become key to remote access applications. Up to now, remote access applications have been based on high-cost, inflexible proprietary solutions to provide

- the communications protocol between a remote location and the embedded system
- the embedded system software
- the graphical user interface at the remote location

If it were possible to use the standard TCP/IP and additional protocols used in the Internet, development costs for remote access solutions would be dramatically reduced:

- the communications protocols are standard: PPP, Ethernet, TCP/IP, UDP, HTTP, FTP
- the graphical user interface is available on every PC without costs: a standard Internet Browser (e. g. Netscape Communicator or Microsoft Internet Explorer).

So it has become necessary to provide a communication software solution for microcontrollers which supports the protocols mentioned above.

1.3. Embedded Web Server

To fit these demands, a Web server has to become "Embedded". An Embedded Web Server works with minimal resource requirements, handles the protocols and provides the low-level functions required to access the hardware.

The product described in this documentation is a hardware and software reference design to demonstrate the NEC V850E family of microcontrollers as a platform for Embedded Web Server technology.

2. Product Overview

2.1. Product Function

The V850 Web Server Demonstration Kit has two main functions:

- to demonstrate how the product can be accessed via TCP/IP with a standard web browser to show and control some product properties by using HTML web pages
- to enable the running of OEM application code as a part of the embedded Web Server.

2.2. Construction

The demonstration hardware consists of:

- a main board containing all peripheral functions with a plug in place for the microcontroller units
- a microcontroller unit containing the Web Server and demonstration software

In addition, the main board has a second socket for plugging in MCCS (Microcontroller Communication and Controlling System) modules This enables the user to plug in additional peripheral resources (e. g. a socket modem unit) for connecting the board directly to the telephone line without using an external modem.

The difference between the EWS850DU (Demo Unit) and the EWS850EU (Eva Unit) is, that the Demo Unit contains a microcontroller and the Eva Unit contains a socket for the microcontroller with it.

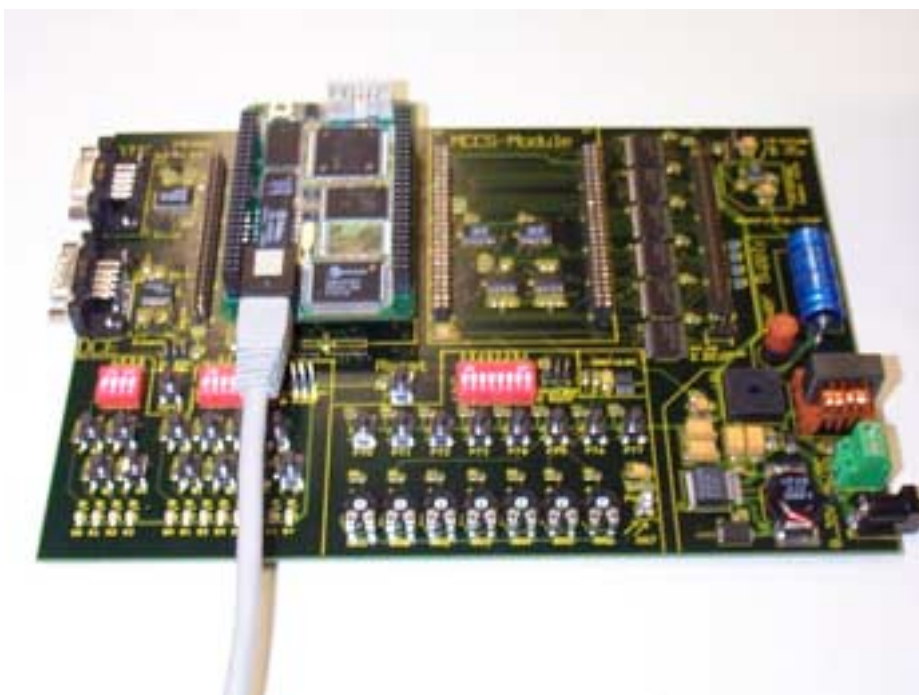

3. Product Properties

3.1. Block Diagram

3.1.1. Main Board

The block diagram for the board is shown in the following figure:

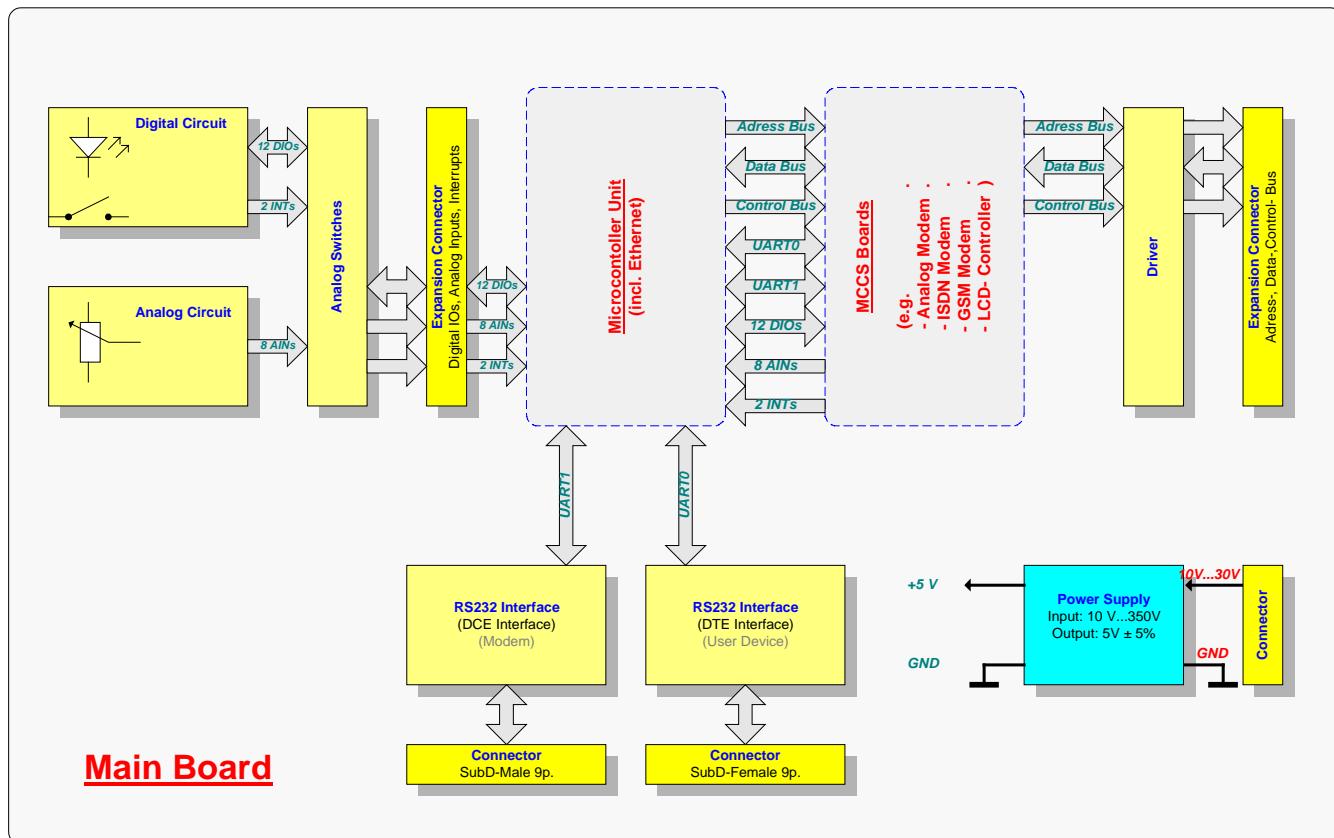

The main board contains the following functions:

- power supply
- socket for microcontroller unit (connectors compatible with MCCS)
- socket for MCCS modules (e. g. socket modem)
- digital circuit for connecting 12 digital I/Os and 2 interrupt lines of the microcontroller unit
- analog circuit for connecting 8 analog inputs of the microcontroller unit
- expansion connector with the 12 digital I/O lines, the 2 interrupt lines and the 8 analog lines (for connecting custom-specific designs)
- expansion connector with the address-, data- and control-bus of the microcontroller unit (for connecting proprietary hardware)
- RS232- interface (DCE- interface) for connecting an external modem
- RS232- interface (DTE- interface) for connecting proprietary devices
- Flash programming circuit

3.1.2. Microcontroller Unit

The block diagram of the microcontroller unit is shown in the following figure:

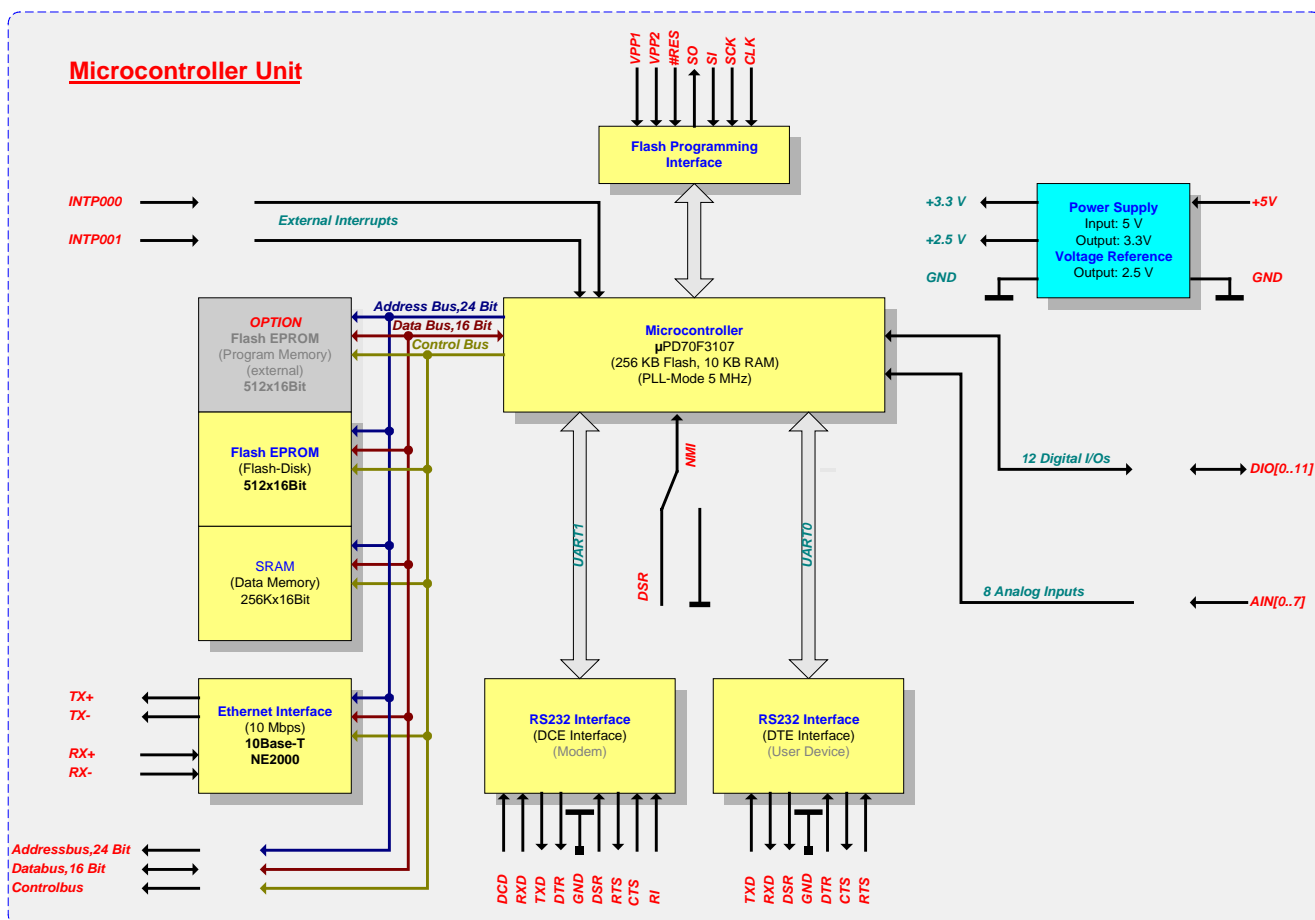

The microcontroller unit contains the following functions:

- power supply
- microcontroller NEC μ PD70F3107
- flash programming interface (for the internal flash of the microcontroller)
- data memory (SRAM 256 K x 16 bit)
- flash (512 K x 16 Bit)
- Memory expansion slot for connecting external program memory (Flash EPROM 512 K x 16 Bit)
- Ethernet- controller with 10BaseT- interface

The connector to the socket interface of the main board contains the following microcontroller signals

- 12 digital I/Os
- 2 interrupt lines
- 8 analog inputs
- 2 UART- interfaces

All external signals are 5 V- tolerant. The internal value of the power line is 3.3 V.

3.2. Description Of The Main Board

3.2.1. Drawing

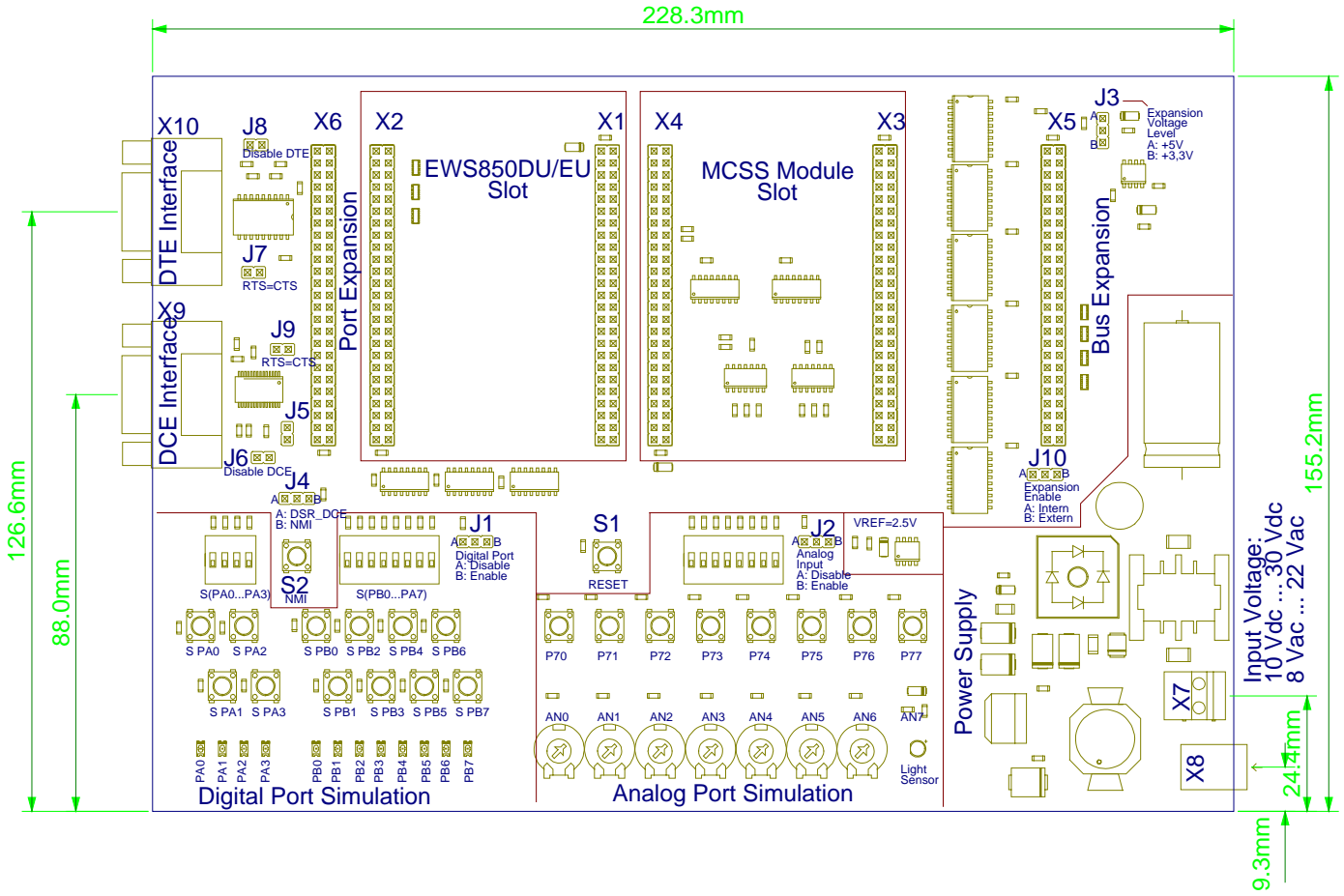

3.2.2. Power Supply

The power supply contains a switching voltage regulator with the following specification:

- input voltage range $10 V_{DC/AC} \dots 30 V_{DC/AC}$
- output voltage $5.0 V_{DC} \pm 5 \%$
- output current max. 1.5 A
- efficiency min. 75 %

3.2.3. Socket For The Microcontroller Unit

The socket for the microcontroller is compatible with the MCCS definition. That means it consists of two connectors:

- one for the port lines
- one for memory expansion lines.

Each connector is a standard female connector containing 50 pins (2 x 25).

The port line connector contains the following signals:

- a 8- bit- digital- I/O- port PB[0..7]
- a 4- bit- digital- I/O- port PA[0..3]
- two interrupt lines #IRQ4, #IRQ5
- a 8- bit- analog- input- port P7[0..7]
- the serial DTE- interface RXD_DTE, TXD_DTE, CTS_DTE, RTS_DTE
- the serial DCE- interface TXD_DCE, RXD_DCE, RTS_DCE, CTS_DCE,
DTR_DCE, DSR_DCE, RI_DCE
- power supply lines +5V, GND, +5V_{analog}, VREF
- control lines #RESET, CLK, #BREQ, #BACK, #CS[0..2]

The memory expansion connector contains the following signals:

- 24- bit- address- lines A[0..23]
- 16- bit- data- lines D[0..15]
- control lines #RESOUT, CLK, #AS, #RD, #WRL, #WRH, #WAIT
- power supply lines +5V, GND

The character “#” characterizes low active signals. For details about the assignment between this signals and the microcontroller ports see 3.3.2.

Because both sockets (for microcontroller unit and MCCS module) are mechanical and electrical compatible, all corresponding signals are connected.

For realizing the ROM monitor it is necessary to connect the DSR signal to the NMI input of the microcontroller.

3.2.4. Socket For The MCCS Modules

The socket for the MCCS modules consists of two connectors:

- one for the port lines
- one for memory expansion lines.

Each connector is a standard female connector containing 50 pins (2 x 25).

The port line connector contains the following signals:

- a 8- bit- digital- I/O- port PB[0..7]
- a 4- bit- digital- I/O- port PA[0..3]
- two interrupt lines #IRQ4, #IRQ5
- a 8- bit- analog- input- port P7[0..7]
- the serial DTE- interface RXD_DTE, TXD_DTE, CTS_DTE, RTS_DTE
- the serial DCE- interface TXD_DCE, RXD_DCE, RTS_DCE, CTS_DCE,
- DTR_DCE, DSR_DCE, RI_DCE
- power supply lines +5V, GND, +5V_{analog}, VREF
- control lines #RESET, CLK, #BREQ, #BACK, #CS[0..2]

The memory expansion connector contains the following signals:

- 24- bit- address- lines A[0..23]
- 16- bit- data- lines D[0..15]
- control lines #RESOUT, CLK, #AS, #RD, #WRL, #WRH, #WAIT
- power supply lines +5V, GND

The character “#” characterizes low active signals. For details about the function of this signals see 3.4.

Because both sockets (for microcontroller unit and MCCS module) are mechanical and electrical compatible, all corresponding signals are connected.

3.2.6. Analog Circuit

3.2.6.1. Schematic

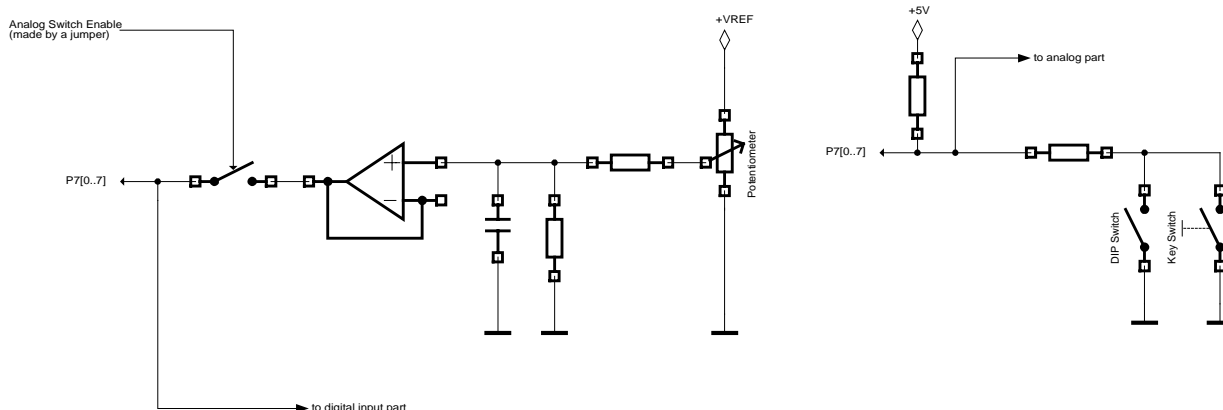

3.2.6.2. Analog Input Function

The analog input function of the analog input ports can be tested with the changing the value of the potentiometer. **In this case do not close one of the switches !**

Potentiometer Value (Examples for VREF =5 V)	Analog Input Level	Switches
0.000 V	0 LSB (00h)	must be open (!)
1.953 V	400 LSB (190h)	must be open (!)
2.500 V	512 LSB (200h)	must be open (!)
4.995 V	1.023 LSB (3FFh)	must be open (!)

3.2.6.3. Input Function

The input function of the ports can be tested with the DIP Switch or the Key Switch. **In this case the jumper must be open !**

DIP Switch	Key Switch	Input Level
open	Open	High (1)
open	Closed	low (0)
closed	Open	low (0)
closed	Closed	low (0)

The analog input port AN7 = P77 contains instead of the potentiometer a light sensor (photo diode or photo transistor). The sensitivity and the electronic circuit should be dimensioned so, that it is possible to distinguish between daylight, lamp light and darkness.

3.2.7. RS232 Interfaces

3.2.7.1. DCE Interface

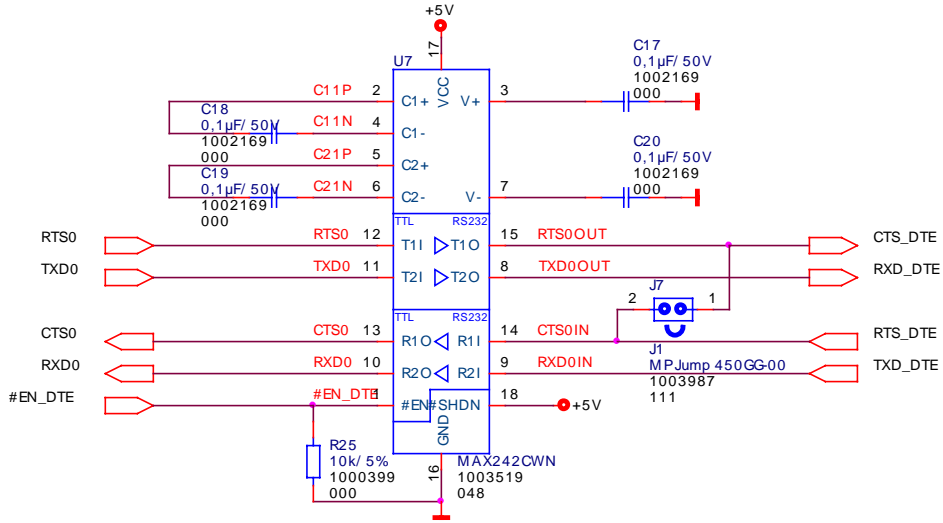

If a MCCS module is available to use the interface of the UART0 (_DTE signals, e. g. by a user designed circuit) the MAX242 has to be disabled.

3.2.7.2. DTE Interface

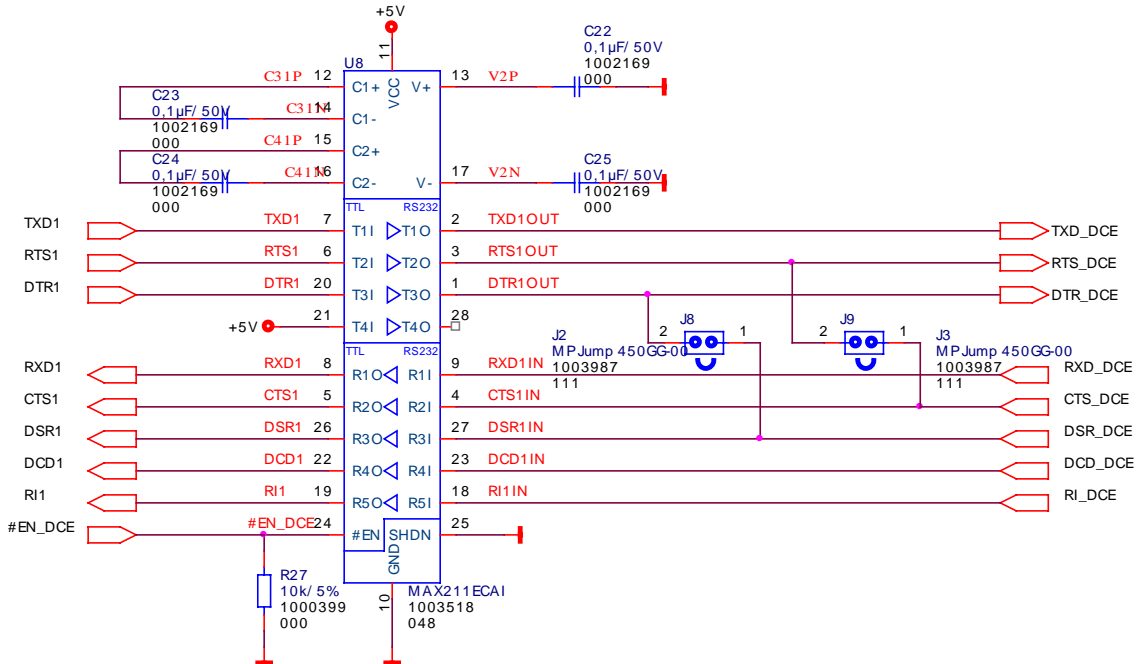

If a MCCS module is available to use the interface of the UART1 (_DCE signals, e. g. by a socket modem) the MAX211 will be disabled.

3.3. Description Of The Microcontroller Unit

3.3.1. Drawing

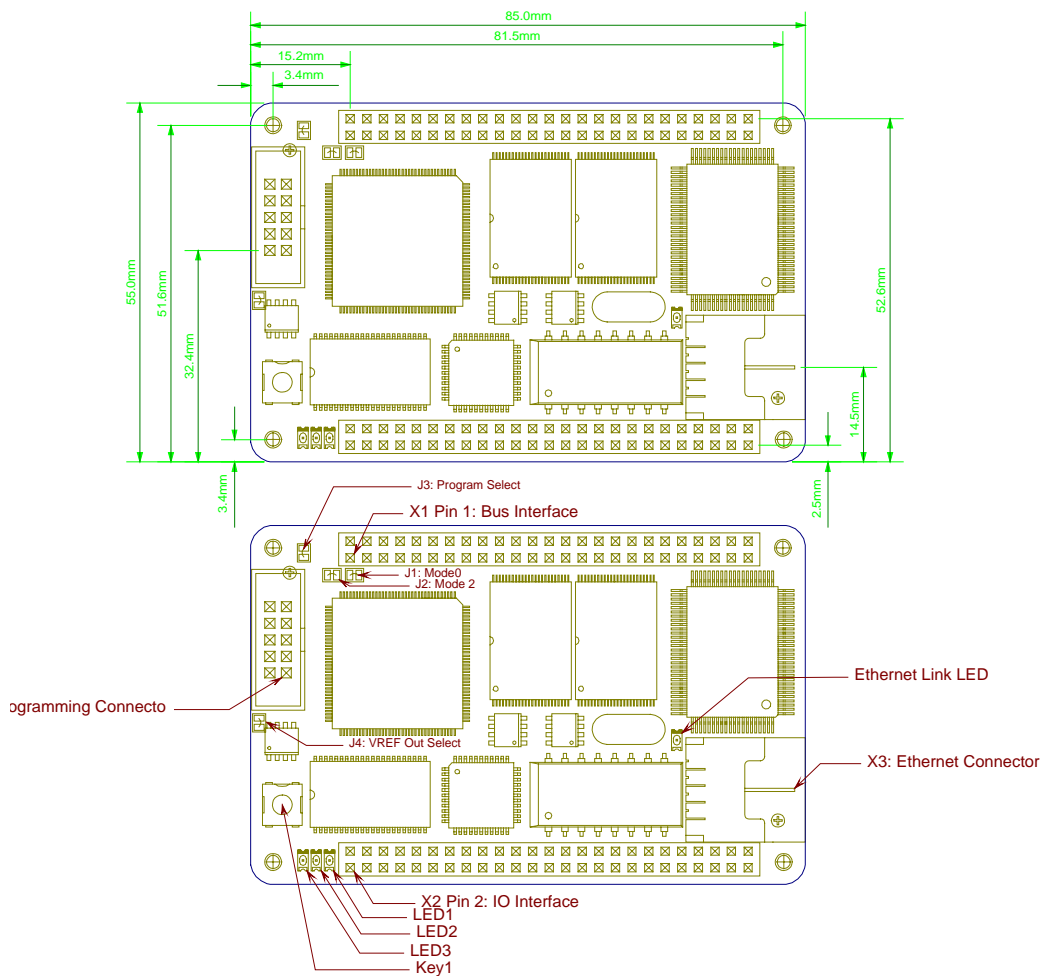

3.3.2. Power Supply

The power supply generates the logic voltage (3.3 V) and the analog reference voltage (2.56 V) for the analog- digital- conversion.

Specification for the logic voltage power supply:

- input voltage range 5.0 V_{DC} ± 5 %
- output voltage 3.3 V_{DC} ± 5 %
- output current max. 500 mA

Specification for the analog voltage power supply:

- input voltage range 5.0 V_{DC} ± 5 %
- output voltage 2.500 V_{DC} ± 1 %
- output current max. 2,5 mA

3.3.3. Microcontroller

3.3.3.1. Features

The microcontroller NEC μ PD70F3107GJ-UEN has the following features:

- 256 Kbytes internal Flash-EPROM as program memory
- 10 Kbytes internal SRAM as data memory
- external memory interface (26 address lines for 64 Mbytes address space, 16- bit data bus)
- internal 10- bit- ADC with eight multiplexed inputs
- internal 50 MHz clock by using a PLL with only external 5 MHz oscillator

3.3.3.2. Pin Assignment

In the following table is shown the pin assignment:

Pin No.	Pin Name	Used Function	Direction	Signal Name	Description	Note
26	P00	P00	I/O	PB0	Digital I/O Port	Pull- Up
25	P01	P01	I/O	PB1	Digital I/O Port	Pull- Up
24	P02	P02	I/O	PB2	Digital I/O Port	Pull- Up
23	P03	P03	I/O	PB3	Digital I/O Port	Pull- Up
22	P04	P04	I/O	PB4	Digital I/O Port	Pull- Up
21	P05	P05	I/O	PB5	Digital I/O Port	Pull- Up
20	P06	P06	I/O	PB6	Digital I/O Port	Pull- Up
19	P07	P07	I/O	PB7	Digital I/O Port	Pull- Up
36	P10	P10	Input	RTS_DTE (RTS0)	RTS- Signal Of The DTE- Interface	Pull- Up
35	P11	P11	Output	CTS_DTE (CTS0)	CTS- Signal Of The DTE- Interface	Pull- Up
34	P12	P12	Input	CTS_DCE (CTS1)	CTS- Signal Of The DCE- Interface	Pull- Up
33	P13	P13	Output	RTS_DCE (RTS1)	RTS- Signal Of The DCE- Interface	Pull- Up
46	P20	NMI	Input	DSR_DCE (DSR1)	DSR- Signal Of The DCE- Interface	Pull- Up
45	P21	P21	Input	DSR_DCE (DSR1)	DSR- Signal Of The DCE- Interface	Pull- Up
44	P22	P22/INTP021	Input	RI_DCE (RI1)	RI- Signal Of The DCE- Interface	Pull- Up
43	P23	P23	Input	DCD_DCE (DCD1)	DCD- Signal Of The DCE- Interface	Pull- Up
42	P24	INTP110	Input	#IRQ4	External Interrupt	Pull- Up
41	P25	INTP111	Input	#IRQ5	External Interrupt	Pull- Up
40	P26	INTP112	Input	#IRQ_9008	Interrupt from Ethernet controller	Pull- Up
39	P27	P27	Input	PrgSelect	J3=closed: external Flash enabled J3=open: no external Program Flash	Pull- Up

Chapter 3 Product Properties

Pin No.	Pin Name	Used Function	Direction	Signal Name	Description	Note
56	P30	P30	Output	DTR_DCE (DTR1)	DTR- Signal Of The DCE- Interface	
55	P31	P31	Input	None	Not Used	Pull- Up
54	P32	P32	Input	None	Not Used	Pull- Up
53	P33	TXD1	Output	TXD_DCE (TXD1)	TXD- Signal Of The DCE- Interface	
52	P34	RXD1	Input	RXD_DCE (RXD1)	RXD- Signal Of The DCE- Interface	Pull- Up
51	P35	P35	Input	None	Not Used	
50	P36	P36	Input	None	Not Used	Pull- Up
49	P37	P37	Input	None	Not Used	Pull- Up
70	P40	SO0	Output	FishPrSO (*)	Flash Programming Interface	
69	P41	SI0	Input	FishPrSI (*)	Flash Programming Interface	Pull- Up
68	P42	None	Input	FishPrCK (*)	Flash Programming Interface	Pull- Up
67	P43	TXD1	Output	TXD_DCE (TXD0)	TXD- Signal Of The DTE- Interface	
66	P44	RXD1	Input	RXD_DCE (RXD0)	RXD- Signal Of The DTE- Interface	Pull- Up
65	P45	None	Input	None	Not Used	Pull- Up
85	P50	None	Input	None	Not Used	Pull- Up
84	P51	None	Input	None	Not Used	Pull- Up
83	P52	None	Input	None	Not Used	Pull- Up
80	P70	P70/AIN0	Input	P70	Digital Input Or Analog Input, Channel 0	Pull- Down
79	P71	P71/AIN1	Input	P71	Digital Input Or Analog Input, Channel 1	Pull- Down
78	P72	P72/AIN2	Input	P72	Digital Input Or Analog Input, Channel 2	Pull- Down
77	P73	P73/AIN3	Input	P73	Digital Input Or Analog Input, Channel 3	Pull- Down
76	P74	P74/AIN4	Input	P74	Digital Input Or Analog Input, Channel 4	Pull- Down
75	P75	P75/AIN5	Input	P75	Digital Input Or Analog Input, Channel 5	Pull- Down
74	P76	P76/AIN6	Input	P76	Digital Input Or Analog Input, Channel 6	Pull- Down
73	P77	P77/AIN7	Input	P77	Digital Input Or Analog Input, Channel 7	Pull- Down
29	PBD0	PBD0	I/O	PA0	Digital I/O Port	Pull- Up
30	PBD1	PBD1	I/O	PA1	Digital I/O Port	Pull- Up
31	PBD2	PBD2	I/O	PA2	Digital I/O Port	Pull- Up
32	PBD3	PBD3	I/O	PA3	Digital I/O Port	Pull- Up
91	PCM0	/WAIT	Input	#WAIT	External Wait States	Pull- Up
90	PCM1	BUSCLK	Output	CLKOUT	Bus Clock	Pull- Up
89	PCM2	/HLDAK	Output	#BACK	Acknowledge For External Bus Request	Pull- Up
88	PCM3	/HLDRQ	Input	#BREQ	External Bus Request	Pull- Up
87	PCM4	/REFRQ	Output	None	Not Used	Pull- Up
86	PCM5	SELFREF	Input	None	Not Used	Pull- Up
97	PCT0	/LWR	Output	#WRL	Write Cycle Low Byte	Pull- Up
96	PCT1	/UWR	Output	#WRH	Write Cycle High Byte	Pull- Up
95	PCT4	/RD	Output	#RD	Read Cycle	Pull- Up
94	PCT5	PCT5	Output	LED3_ON	0 = LED3 off, 1 = LED3 on	Pull- Up
93	PCT6	PCT6	Output	LED2_ON	0 = LED2 off, 1 = LED2 on	Pull- Up
92	PCT7	PCT7	Output	LED1_ON	0 = LED1 off, 1 = LED1 on	Pull- Up
107	PCS0	/CS0	Output	#CS0	Chip Select External Program Memory	Pull- Up
106	PCS1	/CS1	Output	#CS1	Chip Select External Flash Disk	Pull- Up
105	PCS2	/CS2	Output	#CS2	Chip Select External Data Memory	Pull- Up
104	PCS3	/CS3	Output	#CS3	Chip Select External Connector	Pull- Up
103	PCS4	PCS4	Output	None	Not Used	Pull- Up
102	PCS5	/CS5	Output	#CS5	Chip Select Ethernet Controller	Pull- Up
101	PCS6	PCS6	Output	None	Not Used	Pull- Up
100	PCS7	PCS7	Output	WDI	Trigger external Watchdog	Pull- Up
111	PCD0	PCD0	Input	None	Not Used	Pull- Up
110	PCD1	PCD1	Input	#Switch1	Input User Switch (0 = closed)	Pull- Up
109	PCD2	#LBE	Output	#LBE	Memory Select Lower Bank	Pull- Up
108	PCD3	#UBE	Output	#UBE	Memory Select Upper Bank	Pull- Up

Chapter 3 Product Properties

Pin No.	Pin Name	Used Function	Direction	Signal Name	Description	Note
123	PAH0	A16	Output	A16	Address Line, Bit 16	Pull- Up
122	PAH1	A17	Output	A17	Address Line, Bit 17	Pull- Up
121	PAH2	A18	Output	A18	Address Line, Bit 18	Pull- Up
120	PAH3	A19	Output	A19	Address Line, Bit 19	Pull- Up
119	PAH4	A20	Output	A20	Address Line, Bit 20	Pull- Up
118	PAH5	A21	Output	A21	Address Line, Bit 21	Pull- Up
117	PAH6	A22	Output	A22	Address Line, Bit 22	Pull- Up
116	PAH7	A23	Output	A23	Address Line, Bit 23	Pull- Up
115	PAH8	A24	Output	None	Not Used	Pull- Up
114	PAH9	A25	Output	None	Not Used	Pull- Up
143	PAL0	A0	Output	A0	Address Line, Bit 0	Pull- Up
142	PAL1	A1	Output	A1	Address Line, Bit 1	Pull- Up
141	PAL2	A2	Output	A2	Address Line, Bit 2	Pull- Up
140	PAL3	A3	Output	A3	Address Line, Bit 3	Pull- Up
139	PAL4	A4	Output	A4	Address Line, Bit 4	Pull- Up
138	PAL5	A5	Output	A5	Address Line, Bit 5	Pull- Up
137	PAL6	A6	Output	A6	Address Line, Bit 6	Pull- Up
136	PAL7	A7	Output	A7	Address Line, Bit 7	Pull- Up
133	PAL8	A8	Output	A8	Address Line, Bit 8	Pull- Up
132	PAL9	A9	Output	A9	Address Line, Bit 9	Pull- Up
131	PAL10	A10	Output	A10	Address Line, Bit 10	Pull- Up
130	PAL11	A11	Output	A11	Address Line, Bit 11	Pull- Up
129	PAL12	A12	Output	A12	Address Line, Bit 12	Pull- Up
128	PAL13	A13	Output	A13	Address Line, Bit 13	Pull- Up
127	PAL14	A14	Output	A14	Address Line, Bit 14	Pull- Up
126	PAL15	A15	Output	A15	Address Line, Bit 15	Pull- Up
17	PDL0	D0	Output	D0	Data Line, Bit 0	Pull- Up
16	PDL1	D1	Output	D1	Data Line, Bit 1	Pull- Up
15	PDL2	D2	Output	D2	Data Line, Bit 2	Pull- Up
14	PDL3	D3	Output	D3	Data Line, Bit 3	Pull- Up
13	PDL4	D4	Output	D4	Data Line, Bit 4	Pull- Up
12	PDL5	D5	Output	D5	Data Line, Bit 5	Pull- Up
11	PDL6	D6	Output	D6	Data Line, Bit 6	Pull- Up
10	PDL7	D7	Output	D7	Data Line, Bit 7	Pull- Up
7	PDL8	D8	Output	D8	Data Line, Bit 8	Pull- Up
6	PDL9	D9	Output	D9	Data Line, Bit 9	Pull- Up
5	PDL10	D10	Output	D10	Data Line, Bit 10	Pull- Up
4	PDL11	D11	Output	D11	Data Line, Bit 11	Pull- Up
3	PDL12	D12	Output	D12	Data Line, Bit 12	Pull- Up
2	PDL13	D13	Output	D13	Data Line, Bit 13	Pull- Up
1	PDL14	D14	Output	D14	Data Line, Bit 14	Pull- Up
144	PDL15	D15	Output	D15	Data Line, Bit 15	Pull- Up
58	MODE0	MODE0	Input	MD0	Mode, Bit 0	Jumper
57	MODE1	MODE1	Input	MD1	Mode, Bit 1	Jumper
18	MODE2	MODE2 / VPP	Input	MD2 / VPP	Mode, Bit 2 / Flash Programming Interface	Jumper / 7.8 V
59	/RESET	/RESET	Input	#RES	Reset (also needed for Flash Programming Interface)	Pull- Up
60	CKSEL	CKSEL	Input	GND	PLL Mode	
62	X1	X1	Input	X1/ PCLK	Crystal Oscillator Connection / Flash Programming Interface	5,0000 MHz
63	X2	X2	Output	X2	Crystal Oscillator Connection	
8, 27, 37, 47, 81, 98, 112, 124, 134	VDD	VDD	Power	+3.3V	Power Supply (also needed for Flash Programming Interface)	3.3 V ± 5 %
9, 28, 38, 48, 82, 99, 113, 125, 135	VSS	VSS	Power	GND	Ground (also needed for Flash Programming Interface)	0 V
61	CVDD	CVDD	Power	+3.3V	Power Supply (For Clock Generator)	3.3 V ± 5 %
64	CVSS	CVSS	Power	GND	Ground (For Clock Generator)	0 V
71	AVDD/AVREF	AVDD/AVREF	Power	VREF	Reference Voltage	2.5 V± 1 %
72	AVSS	AVSS	Power	GNDA	Analog Ground	0 V

3.3.3.3. Operating Modes

MODE2	MODE1	MODE0	Operation Mode		Remarks
0 V	L	L	Normal operation mode	ROM-less mode 0	16- bit data bus
0 V	L	H	Normal operation mode	ROM-less mode 1	8- bit data bus
0 V	H	L	Normal operation mode	Single-chip mode 0	Internal ROM area is allocated from address 00.0000H
0 V	H	H	Normal operation mode	Single-chip mode 1	Internal ROM area is allocated from address 10.0000H
7.8 V	H	H/L	Flash memory programming mode		

Any other settings not shown above are not recommended.

The mode signals are adjustable by jumper.

3.3.4. Flash Programming Interface

The microcontroller is on board programmable with a connector providing the necessary signals:

Pin Name	Used Function	Direction	Signal Name	Description	Note
VSS	VSS	Power	GND	Ground	0 V
VDD	VDD	Power	+3.3V	Power Supply	3.3 V ± 5 %
MODE2	VPP	Input	VPP	Mode, Bit 2	7.8 V
P40	SO0	Output	SO	Serial Data Output	Pull- Up
P41	SI0	Input	SI	Serial Data Input	Pull- Up
P42	SCK0	Input	SCK	Serial Data Clock	Pull- Up
/RESET	/RESET	Input	#RES	Reset	Pull- Up
X1	X1	Input	PCLK	Controller Clock	

If the flash programming interface is connected to the microcontroller unit the RS232 interface (DTE) has to be disabled.

3.3.5. External Data Memory

The external data memory is located in a SRAM 256 K x 16 bit (512 Kbytes). The SRAM is decoded with the signal #CS2, that means it is located in the address space as follows:

040.0000h – 07F.FFFFh (4 Mbytes, but every 512 Kbytes is mirrored)
 (depends on the register CSC0, reset value = 2C11h)

Other allocations in the address space are possible by programming the register CSC0, but it is recommendable doing this very carefully !

3.3.6. Ethernet Interface

The NE2000 compatible Davicom DM9008 Ethernet controller provides this interface. It is accessed by a chip select signal from the microcontroller. The base address is 300H. The Ethernet parameter will be stored in a serial EEPROM. The controller will be connected to the microcontroller by a 16 bit data interface.

Every unit contains a unique MAC address.

3.3.7. Expansion Connectors

The expansion connectors are compatible with the MCCS definition. That means it consists of two connectors:

- one for the port lines
- one for memory expansion lines

Each connector is mechanical compatible with the PC104 standard but contains 50 pins (2 x 25).

The port line connector contains the following signals:

- a 8- bit- digital- I/O- port PB[0..7]
- a 4- bit- digital- I/O- port PA[0..3]
- two interrupt lines #IRQ4, #IRQ5
- a 8- bit- analog- input- port P7[0..7]
- the serial DTE- interface RXD_DTE, TXD_DTE, CTS_DTE, RTS_DTE
- the serial DCE- interface TXD_DCE, RXD_DCE, RTS_DCE, CTS_DCE,
- DTR_DCE, DSR_DCE, RI_DCE
- power supply lines +5V, GND, +5V_{analog}, VREF
- control lines #RESET, CLK, #BREQ, #BACK, #CS[0..2]

The memory expansion connector contains the following signals:

- 24- bit- address- lines A[0..23]
- 16- bit- data- lines D[0..15]
- control lines #RESOUT, CLK, #AS, #RD, #WRL, #WRH, #WAIT
- power supply lines +5V, GND

The character “#” characterizes low active signals. For details about the assignment between this signals and the microcontroller ports see 3.3.2. For details about the function of this signals see 3.4.

3.3.8. Additional

For realizing the ROM monitor it is necessary to connect the DSR signal to the NMI input of the microcontroller.

For changing to the ROM monitor there is a jumper connected to a microcontroller port. If this jumper is connected to GND after reset the microcontroller will execute the ROM monitor program.

There is also a key switch connected to the microcontroller for executing a software reset if it is pressed.

3.4. Connectors

3.4.1. Main Board

3.4.1.1. Memory Expansion for Microcontroller Unit

Connector X1 (2x25 pins): Module Connection Bus MCB
 Type: Female Connector, 2 x 25 Pins, Pin Grid 2.54 mm (0.1")

Pin	Name	I/O	Function	Pin	Name	I/O	Function
1	+5V	P	Power Supply +5V	2	+5V	P	Power Supply +5V
3	A0	O	Address Line, Bit 0	4	A1	O	Address Line, Bit 1
5	A2	O	Address Line, Bit 2	6	A3	O	Address Line, Bit 3
7	A4	O	Address Line, Bit 4	8	A5	O	Address Line, Bit 5
9	A6	O	Address Line, Bit 6	10	A7	O	Address Line, Bit 7
11	A8	O	Address Line, Bit 8	12	A9	O	Address Line, Bit 9
13	A10	O	Address Line, Bit 10	14	A11	O	Address Line, Bit 11
15	A12	O	Address Line, Bit 12	16	A13	O	Address Line, Bit 13
17	A14	O	Address Line, Bit 14	18	A15	O	Address Line, Bit 15
19	A16	O	Address Line, Bit 16	20	A17	O	Address Line, Bit 17
21	A18	O	Address Line, Bit 18	22	A19	O	Address Line, Bit 19
23	A20	O	Address Line, Bit 20	24	A21	O	Address Line, Bit 21
25	A22	O	Address Line, Bit 22	26	A23	O	Address Line, Bit 23
27	D0	I/O	Data Line, Bit 0	28	D1	I/O	Data Line, Bit 1
29	D2	I/O	Data Line, Bit 2	30	D3	I/O	Data Line, Bit 3
31	D4	I/O	Data Line, Bit 4	32	D5	I/O	Data Line, Bit 5
33	D6	I/O	Data Line, Bit 6	34	D7	I/O	Data Line, Bit 7
35	D8	I/O	Data Line, Bit 8	36	D9	I/O	Data Line, Bit 9
37	D10	I/O	Data Line, Bit 10	38	D11	I/O	Data Line, Bit 11
39	D12	I/O	Data Line, Bit 12	40	D13	I/O	Data Line, Bit 13
41	D14	I/O	Data Line, Bit 14	42	D15	I/O	Data Line, Bit 15
43	#AS	O	Address Valid (Address Strobe)	44	#RD	O	Read Cycle
45	#WRL	O	Write Cycle, Low Byte	46	#WRH	O	Write Cycle, High Byte
47	#WAIT	I	Inserts Wait States	48	#RES	O	Reset
49	GND	P	Ground	50	GND	P	Ground

Notes:

- I Input
- O Output
- I/O Bi-directional
- P Power Line

For details see:
 NEC Preliminary User's Manual V850E/MA1™

3.4.1.2. Port Expansion for Microcontroller Unit

Connector X2 (2x25 pins): I/O- Ports IOP

Type: Female Connector, 2 x 25 Pins, Pin Grid 2.54 mm (0.1")

Pin	Name	I/O	Function	Pin	Name	I/O	Function
1	GND	P	Ground	2	GND	P	Ground
3	PA0	I/O	Port A, Bit 0	4	PA1	I/O	Port A, Bit 1
5	PA2	I/O	Port A, Bit 2	6	PA3	I/O	Port A, Bit 3
7	PB0	I/O	Port B, Bit 0	8	PB1	I/O	Port B, Bit 1
9	PB2	I/O	Port B, Bit 2	10	PB3	I/O	Port B, Bit 3
11	PB4	I/O	Port B, Bit 4	12	PB5	I/O	Port B, Bit 5
13	PB6	I/O	Port B, Bit 6	14	PB7	I/O	Port B, Bit 7
15	GNDA	P	Analog Ground	16	GNDA	P	Analog Ground
17	P70/AN0	I / A	Port 7, Bit 0 / AD- Channel 0	18	P71/AN1	I / A	Port 7, Bit 1 / AD- Channel 1
19	P/2/AN2	I / A	Port 7, Bit 2 / AD- Channel 2	20	P73/AN3	I / A	Port 7, Bit 3 / AD- Channel 3
21	P/4/AN4	I / A	Port 7, Bit 4 / AD- Channel 4	22	P75/AN5	I / A	Port 7, Bit 5 / AD- Channel 5
23	P/6/AN6	I / A	Port 7, Bit 6 / AD- Channel 6	24	P77/AN7	I / A	Port 7, Bit 7 / AD- Channel 7
25	VREF	I	Reference Voltage +2.56V	26	+5V _{analog}	O	Analog Power Supply +5V
27	#BREQ	I	Bus Request	28	#BACK	O	Bus Acknowledge
29	#CS0	O	Chip Select Flash- EPROM 1	30	#CS1	O	Chip Select Flash- EPROM 2
31	#CS2	O	Chip Select SRAM	32	GND	P	Ground
33	CL	O	Processor Clock	34	#RESIN	I	Reset- Input
35	#IRQ5	I	Interrupt 5	36	#IRQ4	I	Interrupt 4
37	TXD0	O	RXD_DTE (TTL- Level)	38	RXD0	I	TXD_DTE (TTL- Level)
39	CTS0	O	CTS_DTE (TTL- Level)	40	RTS0	I	RTS_DTE (TTL- Level)
41	TXD1	O	TXD_DCE (TTL- Level)	42	RXD1	I	RXD_DCE (TTL- Level)
43	RTS1	O	RTS_DCE (TTL- Level)	44	CTS1	I	CTS_DCE (TTL- Level)
45	DTR1	O	DTR_DCE (TTL- Level)	46	DSR1	I	DSR_DCE (TTL- Level)
47	DCD1	I	DCD_DCE (TTL- Level)	48	RI1	I	RI_DCE (TTL- Level)
49	+5V	P	Power Supply +5V	50	+5V	P	Power Supply +5V

Notes:

- I Input UART0: TXD0, RXD0, CTS0, RTS0 (DTE- Interface)
- O Output UART1: TXD1, RXD1, CTS1, RTS1, DSR1, DTR1, DCD1, RI1 (DCE- Interface)
- I/O Bi-directional
- P Power Line
- A Analog Input

For details see:
 NEC Preliminary User's Manual **V850E/MA1™**

3.4.1.3. Memory Expansion for MCCS Modules

Connector X3 (2x25 pins): Module Connection Bus MCB

Type: Female Connector, 2 x 25 Pins, Pin Grid 2.54 mm (0.1")

Pin	Name	I/O	Function	Pin	Name	I/O	Function
1	+5V	P	Power Supply +5V	2	+5V	P	Power Supply +5V
3	A0	O	Address Line, Bit 0	4	A1	O	Address Line, Bit 1
5	A2	O	Address Line, Bit 2	6	A3	O	Address Line, Bit 3
7	A4	O	Address Line, Bit 4	8	A5	O	Address Line, Bit 5
9	A6	O	Address Line, Bit 6	10	A7	O	Address Line, Bit 7
11	A8	O	Address Line, Bit 8	12	A9	O	Address Line, Bit 9
13	A10	O	Address Line, Bit 10	14	A11	O	Address Line, Bit 11
15	A12	O	Address Line, Bit 12	16	A13	O	Address Line, Bit 13
17	A14	O	Address Line, Bit 14	18	A15	O	Address Line, Bit 15
19	A16	O	Address Line, Bit 16	20	A17	O	Address Line, Bit 17
21	A18	O	Address Line, Bit 18	22	A19	O	Address Line, Bit 19
23	A20	O	Address Line, Bit 20	24	A21	O	Address Line, Bit 21
25	A22	O	Address Line, Bit 22	26	A23	O	Address Line, Bit 23
27	D0	I/O	Data Line, Bit 0	28	D1	I/O	Data Line, Bit 1
29	D2	I/O	Data Line, Bit 2	30	D3	I/O	Data Line, Bit 3
31	D4	I/O	Data Line, Bit 4	32	D5	I/O	Data Line, Bit 5
33	D6	I/O	Data Line, Bit 6	34	D7	I/O	Data Line, Bit 7
35	D8	I/O	Data Line, Bit 8	36	D9	I/O	Data Line, Bit 9
37	D10	I/O	Data Line, Bit 10	38	D11	I/O	Data Line, Bit 11
39	D12	I/O	Data Line, Bit 12	40	D13	I/O	Data Line, Bit 13
41	D14	I/O	Data Line, Bit 14	42	D15	I/O	Data Line, Bit 15
43	#AS	O	Address Valid (Address Strobe)	44	#RD	O	Read Cycle
45	#WRL	O	Write Cycle, Low Byte	46	#WRH	O	Write Cycle, High Byte
47	#WAIT	I	Inserts Wait States	48	#RES	O	Reset
49	GND	P	Ground	50	GND	P	Ground

Notes:

- I Input
- O Output
- I/O Bi-directional
- P Power Line

For details see:

NEC Preliminary User's Manual **V850E/MA1™**

3.4.1.4. Port Expansion for MCCS Modules

Connector X4 (2x25 pins): I/O- Ports IOP

Type: Female Connector, 2 x 25 Pins, Pin Grid 2.54 mm (0.1")

Pin	Name	I/O	Function	Pin	Name	I/O	Function
1	GND	P	Ground	2	GND	P	Ground
3	PA0	I/O	Port A, Bit 0	4	PA1	I/O	Port A, Bit 1
5	PA2	I/O	Port A, Bit 2	6	PA3	I/O	Port A, Bit 3
7	PB0	I/O	Port B, Bit 0	8	PB1	I/O	Port B, Bit 1
9	PB2	I/O	Port B, Bit 2	10	PB3	I/O	Port B, Bit 3
11	PB4	I/O	Port B, Bit 4	12	PB5	I/O	Port B, Bit 5
13	PB6	I/O	Port B, Bit 6	14	PB7	I/O	Port B, Bit 7
15	GNDA	P	Analog Ground	16	GNDA	P	Analog Ground
17	P70/AN0	I / A	Port 7, Bit 0 / AD- Channel 0	18	P71/AN1	I / A	Port 7, Bit 1 / AD- Channel 1
19	P/2/AN2	I / A	Port 7, Bit 2 / AD- Channel 2	20	P73/AN3	I / A	Port 7, Bit 3 / AD- Channel 3
21	P/4/AN4	I / A	Port 7, Bit 4 / AD- Channel 4	22	P75/AN5	I / A	Port 7, Bit 5 / AD- Channel 5
23	P/6/AN6	I / A	Port 7, Bit 6 / AD- Channel 6	24	P77/AN7	I / A	Port 7, Bit 7 / AD- Channel 7
25	VREF	O	Reference Voltage +2.56V	26	+5V _{analog}	O	Analog Power Supply +5V
27	#BREQ	I	Bus Request	28	#BACK	O	Bus Acknowledge
29	#CS0	O	Chip Select Flash- EPROM 1	30	#CS1	O	Chip Select Flash- EPROM 2
31	#CS2	O	Chip Select SRAM	32	GND	P	Ground
33	CL	O	Processor Clock	34	#RESIN	I	Reset- Input
35	#IRQ5	I	Interrupt 5	36	#IRQ4	I	Interrupt 4
37	TXD0	O	RXD_DTE (TTL- Level)	38	RXD0	I	TXD_DTE (TTL- Level)
39	CTS0	O	CTS_DTE (TTL- Level)	40	RTS0	I	RTS_DTE (TTL- Level)
41	TXD1	O	TXD_DCE (TTL- Level)	42	RXD1	I	RXD_DCE (TTL- Level)
43	RTS1	O	RTS_DCE (TTL- Level)	44	CTS1	I	CTS_DCE (TTL- Level)
45	DTR1	O	DTR_DCE (TTL- Level)	46	DSR1	I	DSR_DCE (TTL- Level)
47	DCD1	I	DCD_DCE (TTL- Level)	48	RI1	I	RI_DCE (TTL- Level)
49	+5V	P	Power Supply +5V	50	+5V	P	Power Supply +5V

Notes:

- I Input UART0: TXD0, RXD0, CTS0, RTS0 (DTE- Interface)
- O Output UART1: TXD1, RXD1, CTS1, RTS1, DSR1, DTR1, DCD1, RI1 (DCE- Interface)
- I/O Bi-directional
- P Power Line
- A Analog Input

For details see:
 NEC Preliminary User's Manual **V850E/MA1™**

3.4.1.5. Memory Expansion for User Applications

Connector X5 (2x25 pins): Module Connection Bus MCB

Type: Male Connector, 2 x 25 Pins, Pin Grid 2.54 mm (0.1")

Pin	Name	I/O	Function	Pin	Name	I/O	Function
1	+5V	P	Power Supply +5V	2	+5V	P	Power Supply +5V
3	A0	O	Address Line, Bit 0	4	A1	O	Address Line, Bit 1
5	A2	O	Address Line, Bit 2	6	A3	O	Address Line, Bit 3
7	A4	O	Address Line, Bit 4	8	A5	O	Address Line, Bit 5
9	A6	O	Address Line, Bit 6	10	A7	O	Address Line, Bit 7
11	A8	O	Address Line, Bit 8	12	A9	O	Address Line, Bit 9
13	A10	O	Address Line, Bit 10	14	A11	O	Address Line, Bit 11
15	A12	O	Address Line, Bit 12	16	A13	O	Address Line, Bit 13
17	A14	O	Address Line, Bit 14	18	A15	O	Address Line, Bit 15
19	A16	O	Address Line, Bit 16	20	A17	O	Address Line, Bit 17
21	A18	O	Address Line, Bit 18	22	A19	O	Address Line, Bit 19
23	A20	O	Address Line, Bit 20	24	A21	O	Address Line, Bit 21
25	A22	O	Address Line, Bit 22	26	A23	O	Address Line, Bit 23
27	D0	I/O	Data Line, Bit 0	28	D1	I/O	Data Line, Bit 1
29	D2	I/O	Data Line, Bit 2	30	D3	I/O	Data Line, Bit 3
31	D4	I/O	Data Line, Bit 4	32	D5	I/O	Data Line, Bit 5
33	D6	I/O	Data Line, Bit 6	34	D7	I/O	Data Line, Bit 7
35	D8	I/O	Data Line, Bit 8	36	D9	I/O	Data Line, Bit 9
37	D10	I/O	Data Line, Bit 10	38	D11	I/O	Data Line, Bit 11
39	D12	I/O	Data Line, Bit 12	40	D13	I/O	Data Line, Bit 13
41	D14	I/O	Data Line, Bit 14	42	D15	I/O	Data Line, Bit 15
43	#AS	O	Address Valid (Address Strobe)	44	#RD	O	Read Cycle
45	#WRL	O	Write Cycle, Low Byte	46	#WRH	O	Write Cycle, High Byte
47	#WAIT	I	Inserts Wait States	48	#RES	O	Reset
49	GND	P	Ground	50	GND	P	Ground

Notes:

- I Input
- O Output
- I/O Bi-directional
- P Power Line

For details see:

NEC Preliminary User's Manual **V850E/MA1™**

3.4.1.6. Port Expansion for User Applications

Connector X6 (2x25 pins): I/O- Ports IOP

Type: Male Connector, 2 x 25 Pins, Pin Grid 2.54 mm (0.1")

Pin	Name	I/O	Function	Pin	Name	I/O	Function
1	GND	P	Ground	2	GND	P	Ground
3	PA0	I/O	Port A, Bit 0	4	PA1	I/O	Port A, Bit 1
5	PA2	I/O	Port A, Bit 2	6	PA3	I/O	Port A, Bit 3
7	PB0	I/O	Port B, Bit 0	8	PB1	I/O	Port B, Bit 1
9	PB2	I/O	Port B, Bit 2	10	PB3	I/O	Port B, Bit 3
11	PB4	I/O	Port B, Bit 4	12	PB5	I/O	Port B, Bit 5
13	PB6	I/O	Port B, Bit 6	14	PB7	I/O	Port B, Bit 7
15	GNDA	P	Analog Ground	16	GNDA	P	Analog Ground
17	P70/AN0	I / A	Port 7, Bit 0 / AD- Channel 0	18	P71/AN1	I / A	Port 7, Bit 1 / AD- Channel 1
19	P/2/AN2	I / A	Port 7, Bit 2 / AD- Channel 2	20	P73/AN3	I / A	Port 7, Bit 3 / AD- Channel 3
21	P/4/AN4	I / A	Port 7, Bit 4 / AD- Channel 4	22	P75/AN5	I / A	Port 7, Bit 5 / AD- Channel 5
23	P/6/AN6	I / A	Port 7, Bit 6 / AD- Channel 6	24	P77/AN7	I / A	Port 7, Bit 7 / AD- Channel 7
25	VREF	O	Voltage Reference +2.56V	26	+5V _{analog}	O	Analog Power Supply +5V
27	#BREQ	I	Bus Request	28	#BACK	O	Bus Acknowledge
29	#CS0	O	Chip Select Flash- EPROM 1	30	#CS1	O	Chip Select Flash- EPROM 2
31	#CS2	O	Chip Select SRAM	32	GND	P	Ground
33	CL	O	Processor Clock	34	#RESIN	I	Reset- Input
35	#IRQ5	I	Interrupt 5	36	#IRQ4	I	Interrupt 4
37	TXD0	O	RXD_DTE (TTL- Level)	38	RXD0	I	TXD_DTE (TTL- Level)
39	CTS0	O	CTS_DTE (TTL- Level)	40	RTS0	I	RTS_DTE (TTL- Level)
41	TXD1	O	TXD_DCE (TTL- Level)	42	RXD1	I	RXD_DCE (TTL- Level)
43	RTS1	O	RTS_DCE (TTL- Level)	44	CTS1	I	CTS_DCE (TTL- Level)
45	DTR1	O	DTR_DCE (TTL- Level)	46	DSR1	I	DSR_DCE (TTL- Level)
47	DCD1	I	DCD_DCE (TTL- Level)	48	RI1	I	RI_DCE (TTL- Level)
49	+5V	P	Power Supply +5V	50	+5V	P	Power Supply +5V

Notes:

- I Input UART0: TXD0, RXD0, CTS0, RTS0 (DTE- Interface)
- O Output UART1: TXD1, RXD1, CTS1, RTS1, DSR1, DTR1, DCD1, RI1 (DCE- Interface)
- I/O Bi-directional
- P Power Line
- A Analog Input

For details see:
 NEC Preliminary User's Manual **V850E/MA1™**

3.4.1.7. Serial DTE- Interface (For User Device)

Connector X7 (9 pins): RS232- Interface (DTE- Interface)

Type: SubD- Connector, Female, 9 Pins

Pin	Name	I/O	Function	Pin	Name	I/O	Function
01	None	-	Not Connected	06	(DSR_DTE)	-	Connected with Pin 04
02	RXD_DTE	O	Receive Data for DTE	07	RTS_DTE	I	Request To Send from DTE
03	TXD_DTE	I	Transmit Data from DTE	08	CTS_DTE	O	Clear To Send for DTE
04	(DTR_DTE)	-	Connected with Pin 06	09	None	-	Not Connected
05	GND	P	Ground				

Notes:

- I Input
- O Output
- P Power

3.4.1.8. Serial DCE- Interface (For External Modem)

Connector X8 (9 pins): RS232- Interface (DCE- Interface)

Type: SubD- Connector, Male, 9 Pins

Pin	Name	I/O	Function	Pin	Name	I/O	Function
01	DCD_DCD	I	Data Carrier Detect from DCE	06	DTR_DCE	O	Data Terminal Ready for DCE
02	TXD_DCE	O	Transmit Data for DCE	07	CTS_DCE	I	Clear To Send from DCE
03	RXD_DCE	I	Receive Data from DCE	08	RTS_DCE	O	Request To Send for DCE
04	DSR_DCE	I	Data Send Ready from DCE	09	RI_DCE	I	Ring from DCE
05	GND	P	Ground				

Notes:

- I Input
- O Output
- P Power

3.4.1.9. Power Supply

Connector X9 (2 pins): Power Supply

Pin	Name	I/O	Function	Pin	Name	I/O	Function
01	VIN1	P	Input Voltage, Pin 1	02	VIN2	P	Input Voltage, Pin 2

Notes:

- P Power

The input voltage has not to be polarized.

3.4.2. Microcontroller Unit

3.4.2.1. Memory Expansion

Connector X1 (2x25 pins): Module Connection Bus MCB
 Type: PC104, 2 x 25 Pins, Pin Grid 2.54 mm (0.1")

Pin	Name	I/O	Function	Pin	Name	I/O	Function
1	+5V	P	Power Supply +%V	2	+5V	P	Power Supply +5V
3	A0	O	Address Line, Bit 0	4	A1	O	Address Line, Bit 1
5	A2	O	Address Line, Bit 2	6	A3	O	Address Line, Bit 3
7	A4	O	Address Line, Bit 4	8	A5	O	Address Line, Bit 5
9	A6	O	Address Line, Bit 6	10	A7	O	Address Line, Bit 7
11	A8	O	Address Line, Bit 8	12	A9	O	Address Line, Bit 9
13	A10	O	Address Line, Bit 10	14	A11	O	Address Line, Bit 11
15	A12	O	Address Line, Bit 12	16	A13	O	Address Line, Bit 13
17	A14	O	Address Line, Bit 14	18	A15	O	Address Line, Bit 15
19	A16	O	Address Line, Bit 16	20	A17	O	Address Line, Bit 17
21	A18	O	Address Line, Bit 18	22	A19	O	Address Line, Bit 19
23	A20	O	Address Line, Bit 20	24	A21	O	Address Line, Bit 21
25	A22	O	Address Line, Bit 22	26	A23	O	Address Line, Bit 23
27	D0	I/O	Data Line, Bit 0	28	D1	I/O	Data Line, Bit 1
29	D2	I/O	Data Line, Bit 2	30	D3	I/O	Data Line, Bit 3
31	D4	I/O	Data Line, Bit 4	32	D5	I/O	Data Line, Bit 5
33	D6	I/O	Data Line, Bit 6	34	D7	I/O	Data Line, Bit 7
35	D8	I/O	Data Line, Bit 8	36	D9	I/O	Data Line, Bit 9
37	D10	I/O	Data Line, Bit 10	38	D11	I/O	Data Line, Bit 11
39	D12	I/O	Data Line, Bit 12	40	D13	I/O	Data Line, Bit 13
41	D14	I/O	Data Line, Bit 14	42	D15	I/O	Data Line, Bit 15
43	#AS	O	Address Valid (Address Strobe)	44	#RD	O	Read Cycle
45	#WRL	O	Write Cycle, Low Byte	46	#WRH	O	Write Cycle, High Byte
47	#WAIT	I	Inserts Wait States	48	#RES	O	Reset
49	GND	P	Ground	50	GND	P	Ground

Notes:

- I Input
- O Output
- I/O Bi-directional
- P Power Line

For details see:

NEC Preliminary User's Manual V850E/MA1™

3.4.2.2. Port Expansion

Connector X2 (2x25 pins): I/O- Ports IOP
 Type: PC104, 2 x 25 Pins, Pin Grid 2.54 mm (0.1")

Pin	Name	I/O	Function	Pin	Name	I/O	Function
1	GND	P	Ground	2	GND	P	Ground
3	PA0	I/O	Port A, Bit 0	4	PA1	I/O	Port A, Bit 1
5	PA2	I/O	Port A, Bit 2	6	PA3	I/O	Port A, Bit 3
7	PB0	I/O	Port B, Bit 0	8	PB1	I/O	Port B, Bit 1
9	PB2	I/O	Port B, Bit 2	10	PB3	I/O	Port B, Bit 3
11	PB4	I/O	Port B, Bit 4	12	PB5	I/O	Port B, Bit 5
13	PB6	I/O	Port B, Bit 6	14	PB7	I/O	Port B, Bit 7
15	GNDA	P	Analog Ground	16	GNDA	P	Analog Ground
17	P70/AN0	I / A	Port 7, Bit 0 / AD- Channel 0	18	P71/AN1	I / A	Port 7, Bit 1 / AD- Channel 1
19	P/2/AN2	I / A	Port 7, Bit 2 / AD- Channel 2	20	P73/AN3	I / A	Port 7, Bit 3 / AD- Channel 3
21	P/4/AN4	I / A	Port 7, Bit 4 / AD- Channel 4	22	P75/AN5	I / A	Port 7, Bit 5 / AD- Channel 5
23	P/6/AN6	I / A	Port 7, Bit 6 / AD- Channel 6	24	P77/AN7	I / A	Port 7, Bit 7 / AD- Channel 7
25	VREF	O	Voltage Reference +2.56V	26	+5V _{analog}	I	Analog Power Supply +5V
27	#BREQ	I	Bus Request	28	#BACK	O	Bus Acknowledge
29	#CS0	O	Chip Select Flash- EPROM 1	30	#CS1	O	Chip Select Flash- EPROM 2
31	#CS2	O	Chip Select SRAM	32	GND	P	Ground
33	CL	O	Processor Clock	34	#RESIN	I	Reset- Input
35	#IRQ5	I	Interrupt 5	36	#IRQ4	I	Interrupt 4
37	TXD0	O	RXD_DTE (TTL- Level)	38	RXD0	I	TXD_DTE (TTL- Level)
39	CTS0	O	CTS_DTE (TTL- Level)	40	RTS0	I	RTS_DTE (TTL- Level)
41	TXD1	O	TXD_DCE (TTL- Level)	42	RXD1	I	RXD_DCE (TTL- Level)
43	RTS1	O	RTS_DCE (TTL- Level)	44	CTS1	I	CTS_DCE (TTL- Level)
45	DTR1	O	DTR_DCE (TTL- Level)	46	DSR1	I	DSR_DCE (TTL- Level)
47	DCD1	I	DCD_DCE (TTL- Level)	48	RI1	I	RI_DCE (TTL- Level)
49	+5V	P	Power Supply +5V	50	+5V	P	Power Supply +5V

Notes:

- I Input UART0: TXD0, RXD0, CTS0, RTS0 (DTE- Interface)
- O Output UART1: TXD1, RXD1, CTS1, RTS1, DSR1, DTR1, DCD1, RI1 (DCE- Interface)
- I/O Bi-directional
- P Power Line
- A Analog Input

For details see:
 NEC Preliminary User's Manual **V850E/MA1™**

3.4.2.3. Ethernet Interface

Connector X3 (8 pins): 10BaseT- Interface

Type: AMP Modular Jack (RJ12),8polig (No. 215877-1)

<i>Pin</i>	<i>Name</i>	<i>I/O</i>	<i>Function</i>	<i>Pin</i>	<i>Name</i>	<i>I/O</i>	<i>Function</i>
01	TPTX-	O	Twisted Pair Transmit Data	02	TPTX+	O	Twisted Pair Transmit Data
03	TPRX+	I	Twisted Pair Receive Data	04	None	-	Not Connected
05	None	-	Not Connected	06	TPRX-	I	Twisted Pair Receive Data
07	None	-	Not Connected	08	None	-	Not Connected

Notes:

I Input
O Output
P Power

3.4.2.4. Flash Programming Interface

Connector X4 (10 pins): Flash Programming Interface

Type: Male Connector, 2 x 5 Pins, Pin Grid 2.54 mm (0.1")

<i>Pin</i>	<i>Name</i>	<i>I/O</i>	<i>Function</i>	<i>Pin</i>	<i>Name</i>	<i>I/O</i>	<i>Function</i>
01	SCK0	I	Serial Data Clock	02	VPP	P	Programming Voltage 7.8 V
03	SO0	O	Serial Data Output	04	#RES	I	Reset
05	SI0	I	Serial Data Input	06	None	-	Not Connected
07	VDD	P	Power Supply 3.3 V	08	None	-	Not Connected
09	GND	P	Ground	10	PCLK	I	Controller Clock

Notes:

I Input
O Output
P Power

4. Product Specification

4.1. Mechanical and Climatic Requirements

Operating Temperature Range	0 °C	to	70 °C
Storage Temperature Range	-20 °C	to	85 °C

It is necessary to protect the product against:

water
dew
dust
dirt
mechanical shocks and shaking
mechanical torsion
under and over air pressure
liquid and gaseous chemical substances

4.2. Electrical Requirements

It is necessary to protect the product against operation outside the electrical specifications. This can damage the product.

Do not touch the product in operating mode if the input voltage is on.

It is very important to handle the product carefully concerning electrostatic discharges. Do not touch the product without grounding your body.

4.2.1. Main Board

4.2.1.1. Memory Expansion for Microcontroller Unit

This interface has to be designed to account for the specifications of the other used components especially the microcontroller.

4.2.1.2. Port Expansion for Microcontroller Unit

This interface has to be designed to account for the specifications of the other used components especially the microcontroller.

4.2.1.3. Memory Expansion for MCCS Modules

This interface has to be designed to account for the specifications of the other used components especially the MCCS module.

4.2.1.4. Port Expansion for MCCS Modules

This interface has to be designed to account for the specifications of the other used components especially the MCCS module.

4.2.1.5. Memory Expansion for User Applications

This interface has to be designed to account for the specifications of the other used components especially the microcontroller.

4.2.1.6. Port Expansion for User Applications

This interface has to be designed to account for the specifications of the other used components especially the microcontroller.

4.2.1.7. Serial DTE- Interface (For User Device)

This interface is defined by the V.24 standard.

4.2.1.8. Serial DCE- Interface (For External Modem)

This interface is defined by the V.24 standard.

4.2.1.9. Power Supply

Input Voltage Range: $10 V_{DC/AC}$ to $30 V_{DC/AC}$

4.2.2. Microcontroller Unit

4.2.2.1. Memory Expansion

This interface has to be designed to account for the specifications of the other used components especially the microcontroller.

4.2.2.2. Port Expansion

This interface has to be designed to consider the specifications of the used components especially the microcontroller.

4.2.2.3. Ethernet Interface

This interface is defined by the 10Base-T standard.

4.2.2.4. Flash Programming Interface

This interface has to be designed to account for the specifications of the other used components especially the microcontroller.

4.3. Contents

- Hardware as described in this document
- Power Supply
- Ethernet Cable, 2 meters
- CD with content described above