

ISL72027SEH

3.3V Radiation Tolerant CAN Transceiver, with Listen Mode and Split Termination Output

FN8763
Rev 3.00
August 16, 2016

The Intersil [ISL72027SEH](#) is a 3.3V radiation tolerant CAN transceiver that is compatible with the ISO11898-2 standard for applications calling for Controller Area Network (CAN) serial communication in satellites and aerospace communications and telemetry data processing in harsh industrial environments.

The transceiver can transmit and receive at bus speeds up to 5Mbps. It can drive a 40m cable at 1Mbps per the ISO11898-2 specification. The device is designed to operate over a common-mode range of -7V to +12V with a maximum of 120 nodes. The device has three discrete selectable driver rise/fall time options, a listen mode feature and a split termination output.

Receiver (Rx) inputs feature a “full fail-safe” design, which ensures a logic high Rx output if the Rx inputs are floating, shorted, or terminated but undriven.

The ISL72027SEH is available in an 8 Ld hermetic ceramic flatpack and die form that operate across the temperature range of the -55 °C to +125 °C. The logic inputs are tolerant with 5V systems.

Other CAN transceivers available are the [ISL72026SEH](#) and [ISL72028SEH](#). For a list of differences see [Table 1 on page 2](#).

Related Literature

- [UG051](#), “ISL7202xSEHEVAL1Z Evaluation Board User Guide”
- [TR018](#), “SEE Testing of the ISL72027SEH CAN Transceiver”
- [TR022](#), “Total Dose Testing of the ISL72026SEH, ISL72027SEH and ISL72028SEH CAN Transceivers”

Features

- DLA SMD [5962-15228](#)
- ESD Protection on all pins. 4kV HBM
- Compatible with ISO11898-2
- Operating supply range 3.0V to 3.6V
- Bus pin fault protection to ±20V
- Undervoltage lockout
- Cold spare: powered down devices/nodes will not affect active devices operating in parallel
- Three selectable driver rise and fall times
- Glitch free bus I/O during power-up and power-down
- Full fail-safe (open, short, terminated/undriven) receiver
- Hi Z input allows for 120 nodes on the bus
- High data rates. up to 5Mbps
- Quiescent supply current 7mA (max)
- Listen mode supply current 2mA (max)
- -7V to +12V common-mode input voltage range
- 5V tolerant logic inputs
- Thermal shutdown
- Acceptance tested to 75krad(Si) (LDR) wafer-by-wafer
- Radiation tolerance
 - SEL/B immune to LET 60MeV • cm²/mg
 - Low dose rate (0.01rad(Si)/s) 75krad(Si)

Applications

- Satellites and aerospace communications
- Telemetry data processing
- High-end industrial environments
- Harsh environments

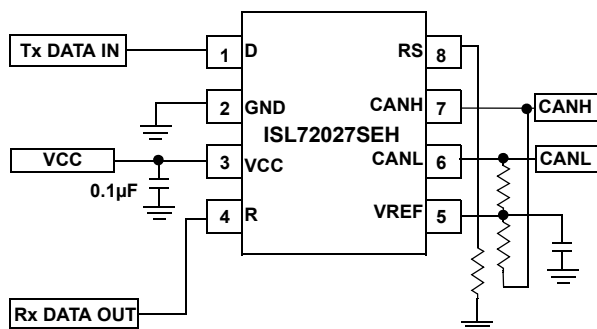

FIGURE 1. TYPICAL APPLICATION

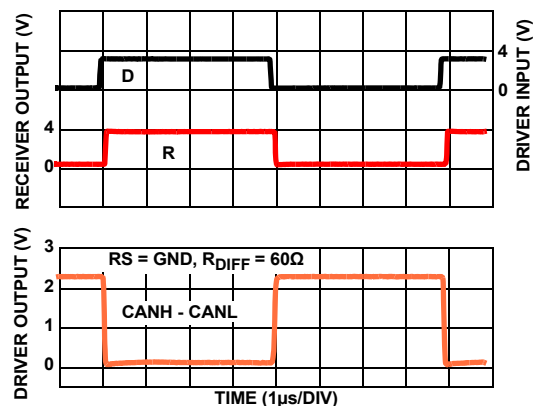

FIGURE 2. FAST DRIVER AND RECEIVER WAVEFORMS

Ordering Information

ORDERING/SMD NUMBER (Note 1)	PART NUMBER (Note 2)	TEMP RANGE (°C)	PACKAGE (RoHS Compliant)	PKG. DWG. #
5962L1522802VXC	ISL72027SEHVF	-55 to +125	8 Ld Ceramic Flatpack	K8.A
N/A	ISL72027SEHF/PROTO	-55 to +125	8 Ld Ceramic Flatpack	K8.A
5962L1522802V9A	ISL72027SEHVX	-55 to +125	Die	
N/A	ISL72027SEHX/SAMPLE	-55 to +125	Die	
N/A	ISL72027SEHEVAL1Z	Evaluation Board		

NOTES:

- Specifications for Radiation Tolerant QML devices are controlled by the Defense Logistics Agency Land and Maritime (DLA). The SMD numbers listed in the Ordering Information must be used when ordering.
- These Intersil Pb-free Hermetic packaged products employ 100% Au plate - e4 termination finish, which is RoHS compliant and compatible with both SnPb and Pb-free soldering operations.

TABLE 1. ISL7202xSEH PRODUCT FAMILY FEATURE TABLE

SPEC	ISL72026SEH	ISL72027SEH	ISL72028SEH
Loopback Feature	Yes	No	No
VREF Output	No	Yes	Yes
Listen Mode	Yes	Yes	No
Shutdown Mode	No	No	Yes
VTHRLM	1150mV (Max)	1150mV (Max)	N/A
VTHFLM	525mV (Min)	525mV (Min)	N/A
VHYSLM	50mV (Min)	50mV (Min)	N/A
Supply Current, Listen Mode	2mA (Max)	2mA (Max)	N/A
Supply Current, Shutdown Mode	N/A	N/A	50µA (Max)
VREF Leakage Current	N/A	±25µA (Max)	±25µA (Max)

N/A: Not Applicable

Pin Configuration

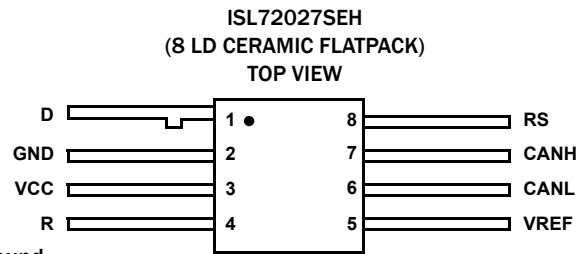

Note: The package lid is tied to ground.

Pin Descriptions

PIN NUMBER	PIN NAME	FUNCTION
1	D	CAN driver digital input. The bus states are LOW = dominant and HIGH = recessive. Internally tied HIGH.
2	GND	Ground connection.
3	VCC	System power supply input (3.0V to 3.6V). The typical voltage for the device is 3.3V.
4	R	CAN data receiver output. The bus states are LOW = dominant and HIGH = recessive.
8	RS	A resistor to GND from this pin controls the rise and fall time of the CAN output waveform. Drive RS HIGH to put into listen mode.
7	CANL	CAN bus line for low level output.
6	CANH	CAN bus line for high level output.
5	VREF	VCC/2 reference output for split mode termination.

Equivalent Input and Output Schematic Diagrams

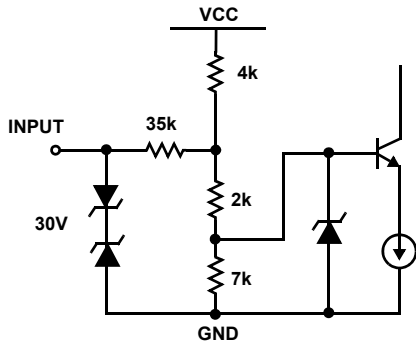

FIGURE 3. CANH AND CANL INPUTS

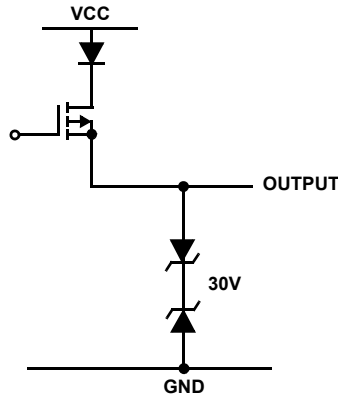

FIGURE 4. CANH OUTPUT

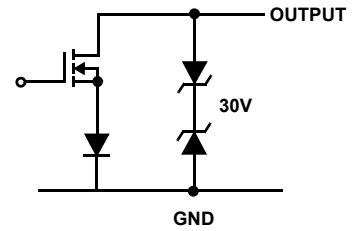

FIGURE 5. CANL OUTPUT

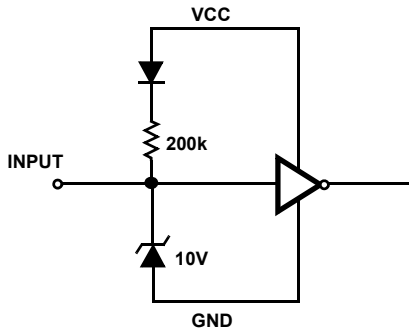

FIGURE 6. D INPUT

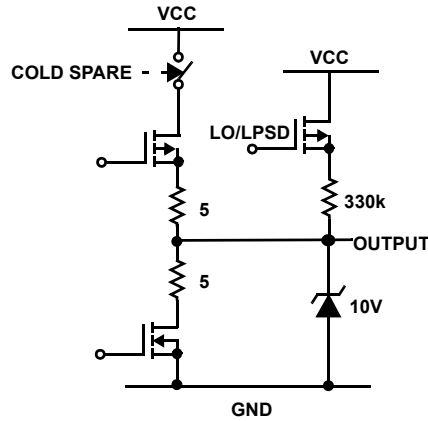

FIGURE 7. R OUTPUT

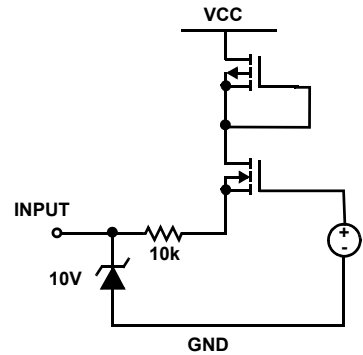

FIGURE 8. RS INPUT

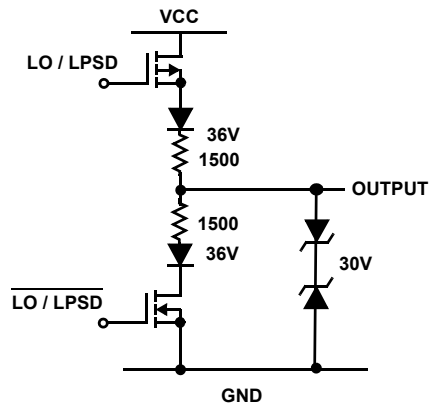

FIGURE 9. VREF

Absolute Maximum Ratings

VCC to GND with/without Ion Beam	-0.3V to 5.5V
CANH, CANL, VREF Under Ion Beam	±18V
CANH, CANL, VREF	±20V
I/O Voltages	
D, R, RS	-0.5V to 7V
Receiver Output Current	-10mA to 10mA
Output Short-circuit Duration	Continuous
ESD Rating:	
Human Body Model (Tested per MIL-PRF-883 3015.7)	
CANH, CANL Bus Pins	4kV
All Other Pins	4kV
Charged Device Model (Tested per JESD22-C101D)	750V
Machine Model (Tested per JESD22-A115-A)	200V

Thermal Information

Thermal Resistance (Typical)	θ_{JA} (°C/W)	θ_{JC} (°C/W)
8 Ld FP Package (Notes 3, 4) Direct Attach	39	7
Maximum Junction Temperature	+175°C	
Storage Temperature Range	-65°C to +150°C	

Recommended Operating Conditions

Temperature Range	-55°C to +125°C
VCC Supply Voltage	3V to 3.6V
Voltage on CAN I/O	-7V to 12V
V _{IH} D Logic Pin	2V to 5.5V
V _{IL} D Logic Pin	0V to 0.8V
IOH Driver (CANH - CANL = 1.5V, VCC = 3.3V)	-40mA
IOH Receiver (V _{OH} = 2.4V)	-4mA
IOL Driver (CANH - CANL = 1.5V, VCC = 3.3V)	+40mA
IOL Receiver (V _{OL} = 0.4V)	+4mA

CAUTION: Do not operate at or near the maximum ratings listed for extended periods of time. Exposure to such conditions may adversely impact product reliability and result in failures not covered by warranty.

- θ_{JA} is measured with the component mounted on a high effective thermal conductivity test board (two buried 1oz copper planes) with “direct attach” features package base mounted to PCB thermal land with a 10 mil gap fill material having a k of 1W/m-K. See Tech Brief [TB379](#).
- For θ_{JC} , the “case temp” location is the center of the package underside.

Electrical Specifications Test Conditions: VCC = 3V to 3.6V; Typicals are at T_A = +25°C (Note 7); unless otherwise specified (Note 5). **Boldface limits apply across the operating temperature range, -55°C to +125°C or across a total ionizing dose of 75krad(Si) at +25°C with exposure at a low dose rate of <10mrad(Si)/s.**

PARAMETER	SYMBOL	TEST CONDITIONS	TEMP (°C)	MIN (Note 6)	TYP (Note 7)	MAX (Note 6)	UNIT
DRIVER ELECTRICAL CHARACTERISTICS							
Dominant Bus Output Voltage	V _{OD(DOM)}	D = 0V, CANH, RS = 0V, Figures 10 and 11	3V ≤ VCC ≤ 3.6V	Full	2.25	2.85	VCC
		D = 0V, CANL, RS = 0V, Figures 10 and 11		Full	0.10	0.65	1.25
Recessive Bus Output Voltage	V _{OD(REC)}	D = 3V, CANH, RS = 0V, 60Ω and no load, Figures 10 and 11	3V ≤ VCC ≤ 3.6V	Full	1.80	2.30	2.70
		D = 3V, CANL, RS = 0V, 60Ω and no load, Figures 10 and 11		Full	1.80	2.30	2.80
Dominant Output Differential Voltage	V _{OD(DOM)}	D = 0V, RS = 0V, 3V ≤ VCC ≤ 3.6V, Figures 10 and 11	3V ≤ VCC ≤ 3.6V	Full	1.5	2.2	3.0
		D = 0V, RS = 0V, 3V ≤ VCC ≤ 3.6V, Figures 11 and 12		Full	1.2	2.1	3.0
Recessive Output Differential Voltage	V _{OD(REC)}	D = 3V, RS = 0V, 3V ≤ VCC ≤ 3.6V, Figures 10 and 11	3V ≤ VCC ≤ 3.6V	Full	-120	0.2	12
		D = 3V, RS = 0V, 3.0V ≤ VCC ≤ 3.6V, no load		Full	-500	-34	50
Logic Input High Voltage (D)	V _{IH}	3V ≤ VCC ≤ 3.6V, Note 8	3V ≤ VCC ≤ 3.6V	Full	2.0	-	5.5
Logic Input Low Voltage (D)	V _{IL}	3V ≤ VCC ≤ 3.6V, Note 8	3V ≤ VCC ≤ 3.6V	Full	0	-	0.8
High Level Input Current (D)	I _{IH}	D = 2V, 3V ≤ VCC ≤ 3.6V	3V ≤ VCC ≤ 3.6V	Full	-30	-3	30
Low Level Input Current (D)	I _{IL}	D = 0.8V, 3V ≤ VCC ≤ 3.6V	3V ≤ VCC ≤ 3.6V	Full	-30	-7	30
RS Input Voltage for Listen Mode	V _{IN(RS)}	3V ≤ VCC ≤ 3.6V	3V ≤ VCC ≤ 3.6V	Full	0.75xVCC	1.90	5.5

Electrical Specifications Test Conditions: $V_{CC} = 3V$ to $3.6V$; Typicals are at $T_A = +25^\circ C$ (Note 7); unless otherwise specified (Note 5).
Boldface limits apply across the operating temperature range, $-55^\circ C$ to $+125^\circ C$ or across a total ionizing dose of $75krad(Si)$ at $+25^\circ C$ with exposure at a low dose rate of $<10mrad(Si)/s$. (Continued)

PARAMETER	SYMBOL	TEST CONDITIONS	TEMP ($^\circ C$)	MIN (Note 6)	TYP (Note 7)	MAX (Note 6)	UNIT
Output Short-Circuit Current	I_{OSC}	$V_{CANH} = -7V$, CANL = OPEN, $3V \leq V_{CC} \leq 3.6V$, Figure 18	Full	-250	-100	-	mA
		$V_{CANH} = +12V$, CANL = OPEN, $3V \leq V_{CC} \leq 3.6V$, Figure 18	Full	-	0.4	1.0	mA
		$V_{CANL} = -7V$, CANH = OPEN, $3V \leq V_{CC} \leq 3.6V$, Figure 18	Full	-1.0	-0.4	-	mA
		$V_{CANL} = +12V$, CANH = OPEN, $3V \leq V_{CC} \leq 3.6V$, Figure 18	Full	-	100	250	mA
Thermal Shutdown Temperature	T_{SHDN}	$3V < V_{IN} < 3.6V$	-	-	163	-	$^\circ C$
Thermal Shutdown Hysteresis	T_{HYS}	$3V < V_{IN} < 3.6V$	-	-	12	-	$^\circ C$
RECEIVER ELECTRICAL CHARACTERISTICS							
Input Threshold Voltage (Rising)	V_{THR}	RS = 0V, 10k, 50k, (recessive to dominant), Figures 14 and 15	Full	-	750	900	mV
Input Threshold Voltage (Falling)	V_{THF}	RS = 0V, 10k, 50k, (dominant to recessive), Figures 14 and 15	Full	500	650	-	mV
Input Hysteresis	V_{HYS}	$(V_{THR} - V_{THF})$, RS = 0V, 10k, 50k, Figures 14 and 15	Full	40	90	-	mV
Listen Mode Input Threshold Voltage (Rising)	V_{THRLM}	RS = V_{CC} , (recessive to dominant), Figure 14	Full	-	920	1150	mV
Listen Mode Input Threshold Voltage (Falling)	V_{THFLM}	RS = V_{CC} , (dominant to recessive), Figure 14	Full	525	820	-	mV
Listen Mode Input Hysteresis	V_{HYSLM}	$(V_{THR} - V_{THF})$, RS = V_{CC} , Figure 14	Full	50	100	-	mV
Receiver Output High Voltage	V_{OH}	$I_O = -4mA$	Full	2.4	$V_{CC} - 0.2$	-	V
Receiver Output Low Voltage	V_{OL}	$I_O = +4mA$	Full	-	0.2	0.4	V
Input Current for CAN Bus	I_{CAN}	CANH or CANL at 12V, D = 3V, other bus pin at 0V, RS = 0V	Full	-	420	500	μA
		CANH or CANL at 12V, D = 3V, $V_{CC} = 0V$, other bus pin at 0V, RS = 0V	Full	-	150	250	μA
		CANH or CANL at -7V, D = 3V, other bus pin at 0V, RS = 0V	Full	-400	-300	-	μA
		CANH or CANL at -7V, D = 3V, $V_{CC} = 0V$, other bus pin at 0V, RS = 0V	Full	-150	-85	-	μA
Input Capacitance (CANH or CANL)	C_{IN}	Input to GND, D = 3V, RS = 0V	25	-	35	-	pF
Differential Input Capacitance	C_{IND}	Input to Input, D = 3V, RS = 0V	25	-	15	-	pF
Input Resistance (CANH or CANL)	R_{IN}	Input to GND, D = 3V, RS = 0V	Full	20	40	50	k Ω
Differential Input Resistance	R_{IND}	Input to Input, D = 3V, RS = 0V	Full	40	80	100	k Ω
SUPPLY CURRENT							
Supply Current, Listen Mode	$I_{CC(L)}$	RS = D = V_{CC} , $3V \leq V_{CC} \leq 3.6V$	Full	-	1	2	mA
Supply Current, Dominant	$I_{CC(DOM)}$	D = RS = 0V, no load, $3V \leq V_{CC} \leq 3.6V$	Full	-	5	7	mA
Supply Current, Recessive	$I_{CC(REC)}$	D = V_{CC} , RS = 0V, no load, $3V \leq V_{CC} \leq 3.6V$	Full	-	2.6	5.0	mA
COLD SPARING BUS CURRENT							
CANH Leakage Current	$I_L(CANH)$	$V_{CC} = 0.2V$, CANH = -7V or 12V, CANL = float, D = V_{CC} , RS = 0V	Full	-25	-4	25	μA
CANL Leakage Current	$I_L(CANL)$	$V_{CC} = 0.2V$, CANL = -7V or 12V, CANH = float, D = V_{CC} , RS = 0V	Full	-25	-4	25	μA
VREF Leakage Current	$I_L(VREF)$	$V_{CC} = 0.2V$, $V_{REF} = -7V$ or 12V, D = V_{CC}	Full	-25.00	0.01	25.00	μA

Electrical Specifications Test Conditions: $V_{CC} = 3V$ to $3.6V$; Typicals are at $T_A = +25^\circ C$ (Note 7); unless otherwise specified (Note 5). **Boldface limits apply across the operating temperature range, $-55^\circ C$ to $+125^\circ C$ or across a total ionizing dose of $75krad(Si)$ at $+25^\circ C$ with exposure at a low dose rate of $<10mrads(Si)/s$. (Continued)**

PARAMETER	SYMBOL	TEST CONDITIONS	TEMP ($^\circ C$)	MIN (Note 6)	TYP (Note 7)	MAX (Note 6)	UNIT
DRIVER SWITCHING CHARACTERISTICS							
Propagation Delay LOW to HIGH	t_{PDLH1}	RS = 0V, Figure 13	Full	-	75	150	ns
Propagation Delay LOW to HIGH	t_{PDLH2}	RS = 10k Ω , Figure 13	Full	-	520	850	ns
Propagation Delay LOW to HIGH	t_{PDLH3}	RS = 50k Ω , Figure 13	Full	-	850	1400	ns
Propagation Delay HIGH to LOW	t_{PDHL1}	RS = 0V, Figure 13	Full	-	80	155	ns
Propagation Delay HIGH to LOW	t_{PDHL2}	RS = 10k Ω , Figure 13	Full	-	460	800	ns
Propagation Delay HIGH to LOW	t_{PDHL3}	RS = 50k Ω , Figure 13	Full	-	725	1300	ns
Output Skew	t_{SKEW1}	RS = 0V, ($ t_{PHL} - t_{PLH} $), Figure 13	Full	-	5	50	ns
Output Skew	t_{SKEW2}	RS = 10k Ω , ($ t_{PHL} - t_{PLH} $), Figure 13	Full	-	60	510	ns
Output Skew	t_{SKEW3}	RS = 50k Ω , ($ t_{PHL} - t_{PLH} $), Figure 13	Full	-	110	800	ns
Output Rise Time	t_{r1}	RS = 0V, (fast speed)	Full	20	55	100	ns
Output Fall Time	t_{f1}	Figure 13	Full	10	25	75	ns
Output Rise Time	t_{r2}	RS = 10k Ω , (medium speed - 250Kbps)	Full	200	400	780	ns
Output Fall Time	t_{f2}	Figure 13	Full	175	300	500	ns
Output Rise Time	t_{r3}	RS = 50k Ω , (slow speed - 125Kbps)	Full	400	700	1400	ns
Output Fall Time	t_{f3}	Figure 13	Full	300	650	1000	ns
Total Loop Delay, Driver Input to Receiver Output, Recessive to Dominant	$t_{(LOOP1)}$	RS = 0V, Figure 16	Full	-	115	210	ns
		RS = 10k Ω , Figure 16	Full	-	550	875	ns
		RS = 50k Ω , Figure 16	Full	-	850	1400	ns
Total Loop Delay, Driver Input to Receiver Output, Dominant to Recessive	$t_{(LOOP2)}$	RS = 0V, Figure 16	Full	-	130	270	ns
		RS = 10k Ω , Figure 16	Full	-	500	825	ns
		RS = 50k Ω , Figure 16	Full	-	750	1300	ns
Listen to Valid Dominant Time	t_{L-DOM}	Figure 17	Full	-	5	15	us
RECEIVER SWITCHING CHARACTERISTICS							
Propagation Delay LOW to HIGH	t_{PLH}	Figure 14	Full	-	50	110	ns
Propagation Delay HIGH to LOW	t_{PHL}	Figure 14	Full	-	50	110	ns
Rx Skew	t_{SKEW1}	$ t_{PHL} - t_{PLH} $, Figure 14	Full	-	2	35	ns
Rx Rise Time	t_r	Figure 14	Full	-	2	-	ns
Rx Fall Time	t_f	Figure 14	Full	-	2	-	ns
VREF/RS PIN CHARACTERISTICS							
VREF Pin Voltage	VREF	$-5\mu A < I_{REF} < 5\mu A$	Full	$0.45 \times V_{CC}$	1.60	$0.55 \times V_{CC}$	V
		$-50\mu A < I_{REF} < 50\mu A$	Full	$0.4 \times V_{CC}$	1.6	$0.6 \times V_{CC}$	V
RS Pin Input Current	$I_{RS(H)}$	RS = $0.75 \times V_{CC}$	Full	-10.0	-0.2	-	μA
	$I_{RS(L)}$	$V_{RS} = 0V$	Full	-450	-125	0	μA

NOTES:

- All currents into device pins are positive; all currents out of device pins are negative. All voltages are referenced to device ground unless otherwise specified.
- Parameters with MIN and/or MAX limits are 100% tested at $-55^\circ C$, $+25^\circ C$ and $+125^\circ C$, unless otherwise specified.
- Typical values are at 3.3V. Parameters with a single entry in the "TYP" column apply to 3.3V. Typical values shown are not guaranteed.
- Parameter included in functional testing.

Test Circuits and Waveforms

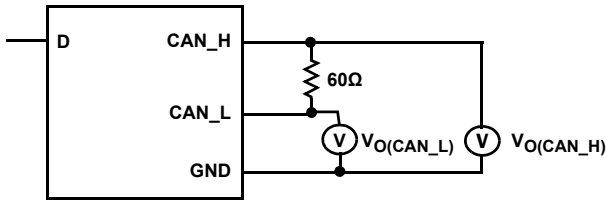

FIGURE 10. DRIVER TEST CIRCUIT

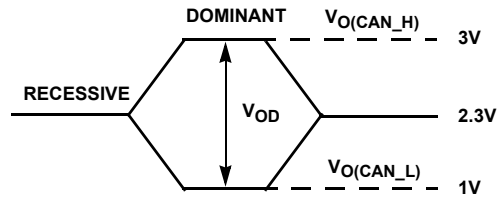

FIGURE 11. DRIVER BUS VOLTAGE DEFINITIONS

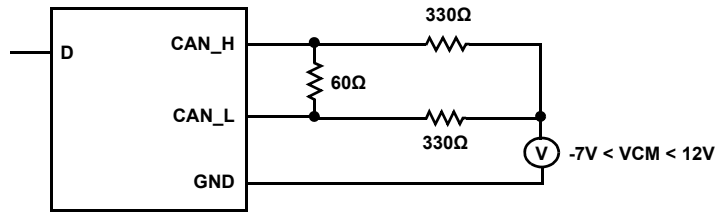
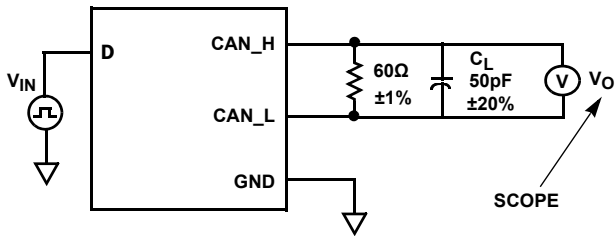

FIGURE 12. DRIVER COMMON-MODE CIRCUIT



$V_{IN} = 125\text{kHz}$, 0V to V_{CC} , Duty Cycle 50%, $t_r = t_f \leq 6\text{ns}$, $Z_O = 50\Omega$
 C_L includes fixture and instrumentation capacitance.

FIGURE 13A. DRIVER TIMING TEST CIRCUIT

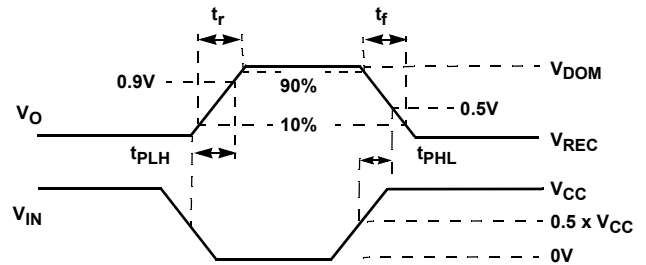

FIGURE 13B. DRIVER TIMING MEASUREMENT POINTS

FIGURE 13. DRIVER TIMING

Test Circuits and Waveforms (Continued)

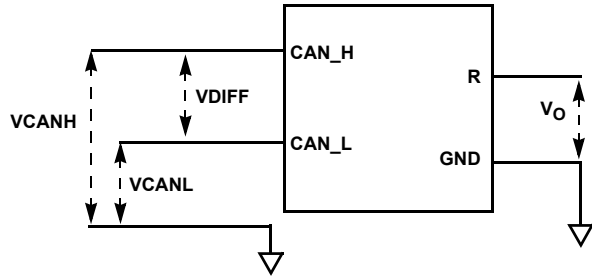
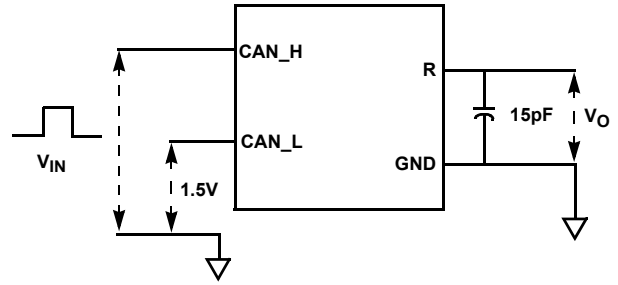

FIGURE 14A. RECEIVER VOLTAGE DEFINITIONS



$V_{IN} = 125\text{kHz}$, Duty Cycle 50%, $t_r = t_f = 6\text{ns}$, $Z_O = 50\Omega$
 C_L includes test setup capacitance

FIGURE 14B. RECEIVER TEST CIRCUIT

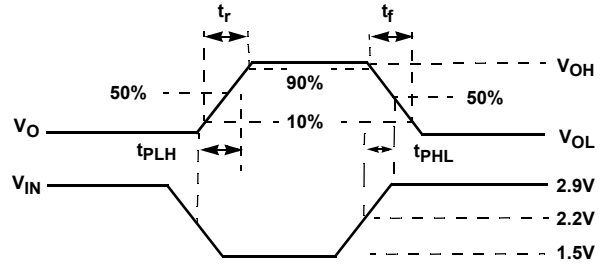

FIGURE 14C. RECEIVER TEST MEASUREMENT POINTS

FIGURE 14. RECEIVER TEST

INPUT		OUTPUT	MEASURED
VCANH	VCANL	R	VDIFF
-6.1V	-7V	L	900mV
12V	11.1V	L	900mV
-1V	-7V	L	6V
12V	6V	L	6V
-6.5V	-7V	H	500mV
12V	11.5V	H	500mV
-7V	-1V	H	6V

FIGURE 15. DIFFERENTIAL INPUT VOLTAGE THRESHOLD TEST

Test Circuits and Waveforms (Continued)

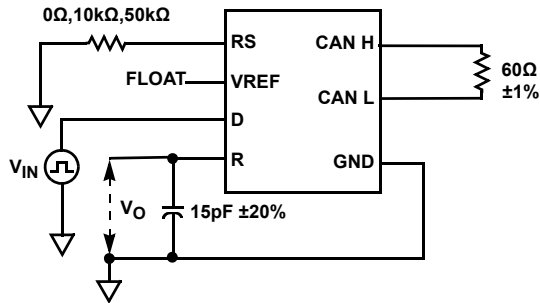

V_{IN} = 125kHz, Duty Cycle 50%, t_r = t_f ≤ 6ns

FIGURE 16A. TOTAL LOOP DELAY TEST CIRCUIT

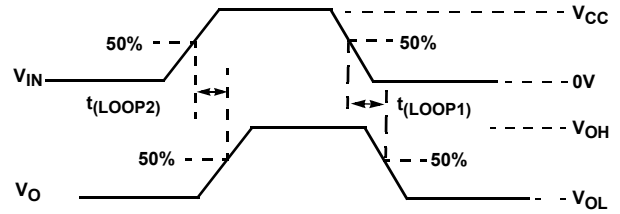
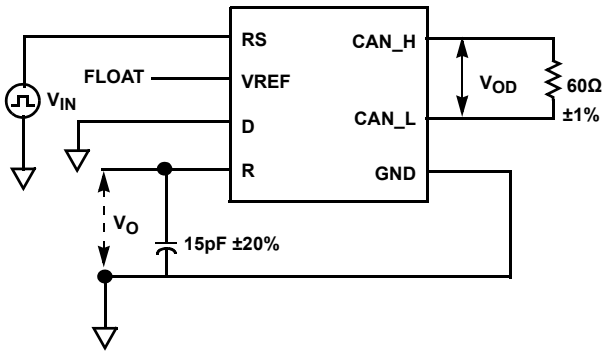

FIGURE 16B. TOTAL LOOP DELAY MEASUREMENT POINTS

FIGURE 16. TOTAL LOOP DELAY



V_{IN} = 125kHz, 0V to V_{CC}, Duty Cycle 50%, t_r = t_f ≤ 6ns

FIGURE 17A. LISTEN TO VALID DOMINANT TIME CIRCUIT

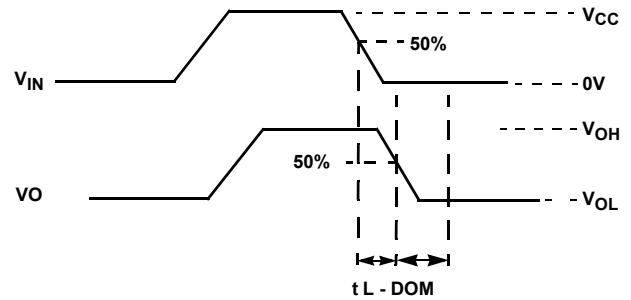

FIGURE 17B. LISTEN TO VALID DOMINANT TIME MEASUREMENT POINTS

FIGURE 17. LISTEN TO VALID DOMINANT TIME

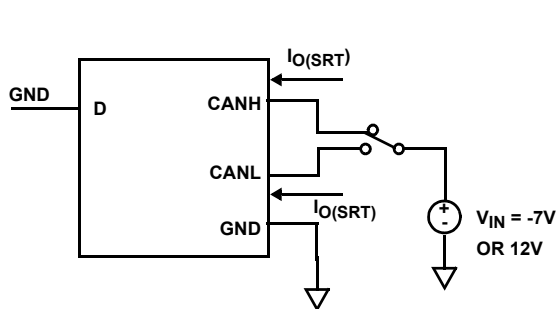

FIGURE 18A. OUTPUT SHORT-CIRCUIT CURRENT CIRCUIT

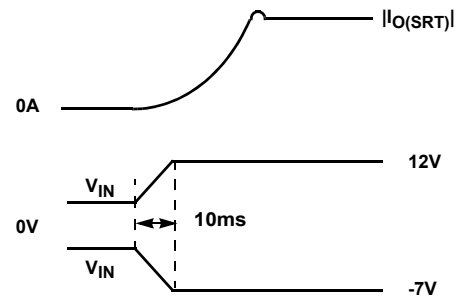

FIGURE 18B. OUTPUT SHORT-CIRCUIT CURRENT WAVEFORMS

FIGURE 18. OUTPUT SHORT-CIRCUIT

Functional Description

Overview

The Intersil ISL72027SEH is a 3.3V radiation tolerant CAN transceiver that is compatible with the ISO11898-2 standard for use in CAN (Controller Area Network) serial communication systems.

The device performs transmit and receive functions between the CAN controller and the CAN differential bus. It can transmit and receive at bus speeds of up to 5Mbps. It is designed to operate over a common-mode range of -7V to +12V with a maximum of 120 nodes. The device is capable of withstanding $\pm 20V$ on the CANH and CANL bus pins outside of ion beam and $\pm 16V$ under ion beam.

Slope Adjustment

The output driver rise and fall time has three distinct selections that may be chosen by using a resistor from the RS pin to GND. Connecting the RS pin directly to GND results in output switching times that are the fastest, limited only by the drive capability of the output stage. $RS = 10k\Omega$ provides for a typical slew rate of $8V/\mu s$ and $RS = 50k\Omega$ provides for a typical slew rate of $4V/\mu s$.

Putting a high logic level to the RS pin places the device in a low current listen mode. The protocol controller uses this mode to switch between low power listen mode and a normal transmit mode.

Cable Length

The device can work per ISO11898 specification with a 40m cable and stub length of 0.3m and 60 nodes at 1Mbps. This is greater than the ISO requirement of 30 nodes. The cable type specified is a twisted pair (shielded or unshielded) with a characteristic impedance of 120Ω . Resistors equal to this are to be terminated at both ends of the cable. Stubs should be kept as short as possible to prevent reflections.

Cold Spare

High reliability system designers implementing data communications have to be sensitive to the potential for single point failures. To mitigate the risk of a failure they will use redundant bus transceivers in parallel. Space systems call for high reliability in data communications that are resistant to single point failures. This is achieved by using a redundant bus transceiver in parallel. In this arrangement, both active and quiescent devices can be present simultaneously on the bus. The quiescent devices are powered down for cold spare and do not affect the communication of the other active nodes.

To achieve this, a powered down transceiver ($V_{CC} < 200mV$) has a resistance between the VREF pin or the CANH pin or CANL pin and the V_{CC} supply rail of $>480k\Omega$ (max) with a typical resistance $>2M\Omega$. The resistance between CANH and CANL of a powered down transceiver has a typical resistance of $80k\Omega$.

Listen Mode

When a high level is applied to the RS pin, the device enters a low power listen mode. The driver of the transceiver is switched off to conserve power while the receiver remains active. In listen mode the transceiver draws 2mA (max) of current.

A low level on the RS pin brings the device back to normal operation.

Using 3.3V Devices in 5V Systems

Looking at the differential voltage of both the 3.3V and 5V devices, the differential voltage is the same, the recessive common-mode output is the same. The dominant common-mode output voltage is slightly lower than the 5V counterparts. The receiver specs are also the same. Though the electrical parameters appear compatible, it is advised that necessary system testing be performed to verify interchangeable operation.

Split Mode Termination

The VREF pin provides a $V_{CC}/2$ output voltage for split mode termination. The VREF pin has the same ESD protection, short-circuit protection, and common-mode operating range as the bus pins.

The split mode termination technique is shown in [Figure 19](#).

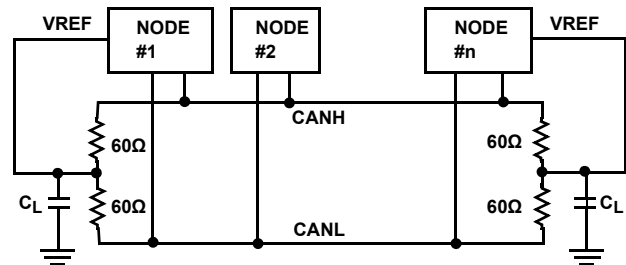

FIGURE 19. SPLIT TERMINATION

It is used to stabilize the bus voltage at $V_{CC}/2$ and prevent it from drifting to a high common-mode voltage during periods of inactivity. The technique improves the electromagnetic compatibility of a network. The split mode termination is put at each end of the bus.

The C_L capacitor between the two 60Ω resistors filters unwanted high frequency noise to ground. The resistors should have a tolerance of 1% or better and the two resistors should be carefully matched to provide the most effective EMI immunity. A typical value of C_L for a high speed CAN network is $4.7nF$, which generates a 3dB point at 1.1Mbps. The capacitance value used is dependent on the signaling rate of the network.

Typical Performance Curves $V_{CC} = 3.3V, C_L = 15pF, T_A = +25^\circ C$; unless otherwise specified.

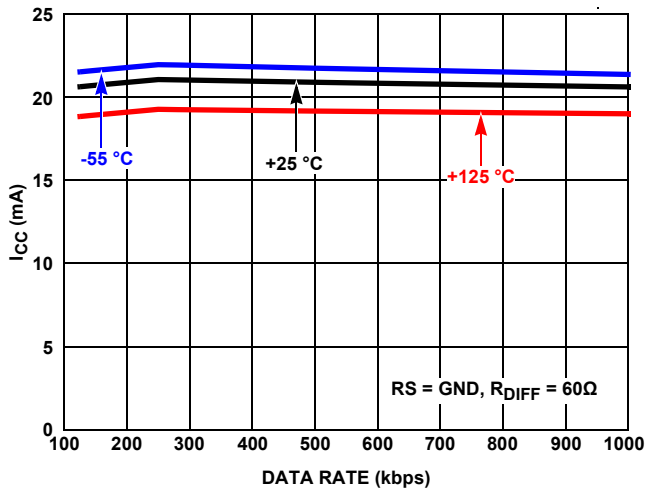

FIGURE 20. SUPPLY CURRENT vs FAST DATA RATE vs TEMPERATURE

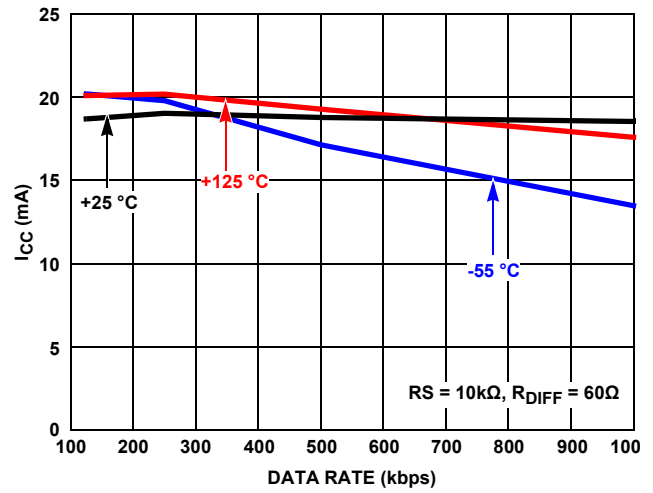

FIGURE 21. SUPPLY CURRENT vs MEDIUM DATA RATE vs TEMPERATURE

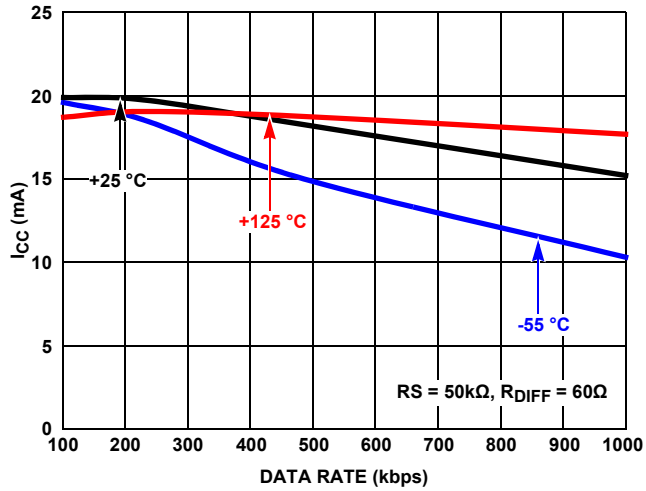

FIGURE 22. SUPPLY CURRENT vs SLOW DATA RATE vs TEMPERATURE

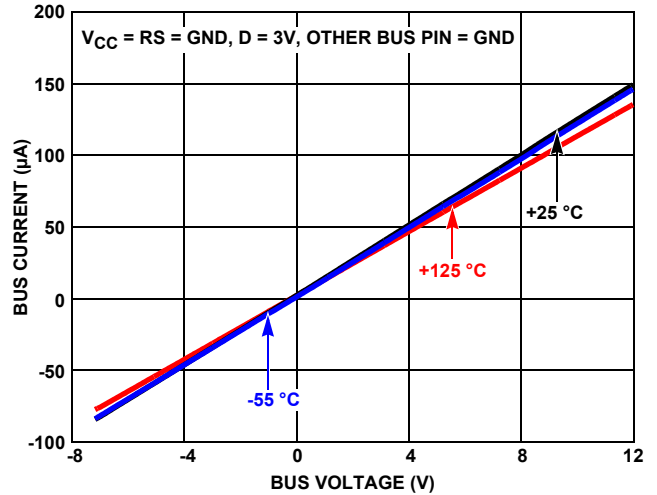

FIGURE 23. BUS PIN LEAKAGE vs VCM AT $V_{CC} = 0V$

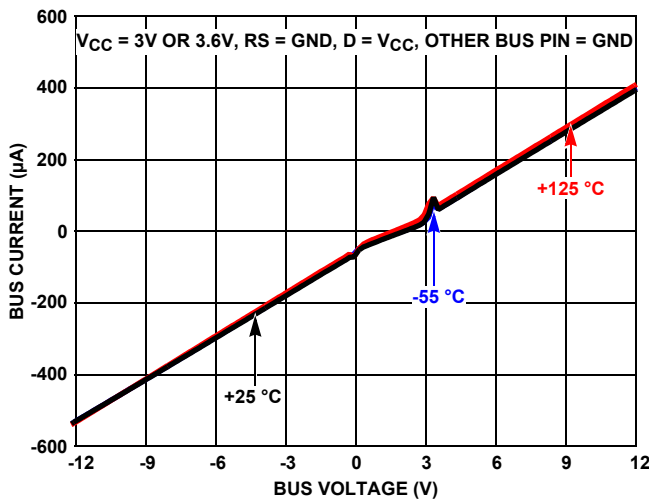

FIGURE 24. BUS PIN LEAKAGE vs $\pm 12V$ VCM

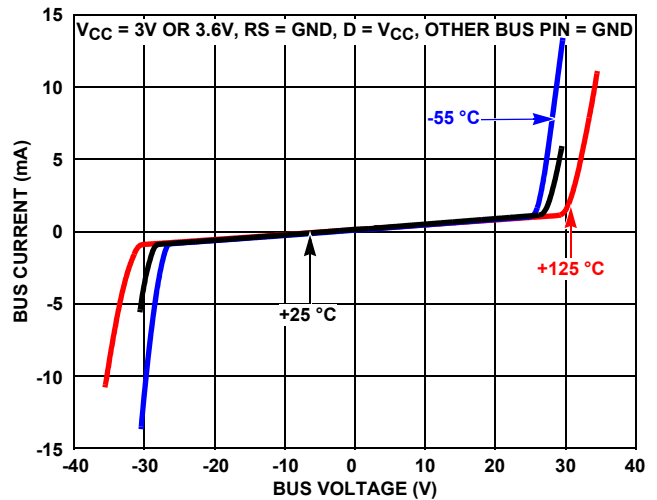

FIGURE 25. BUS PIN LEAKAGE vs $\pm 35V$ VCM

Typical Performance Curves $V_{CC} = 3.3V, C_L = 15pF, T_A = +25^\circ C$; unless otherwise specified. (Continued)

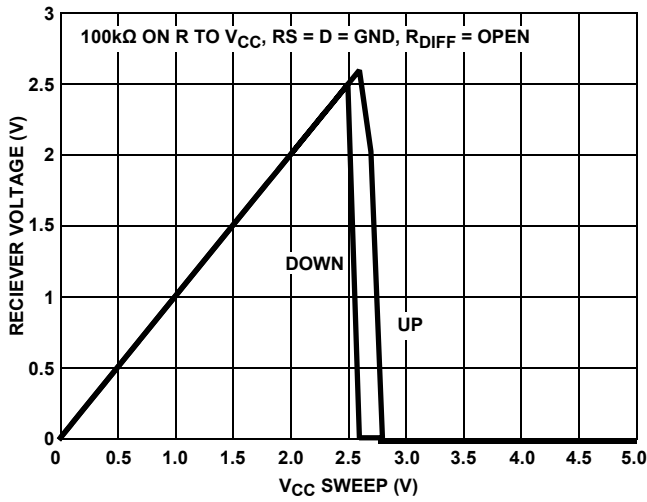

FIGURE 26. V_{CC} UNDERVOLTAGE LOCKOUT

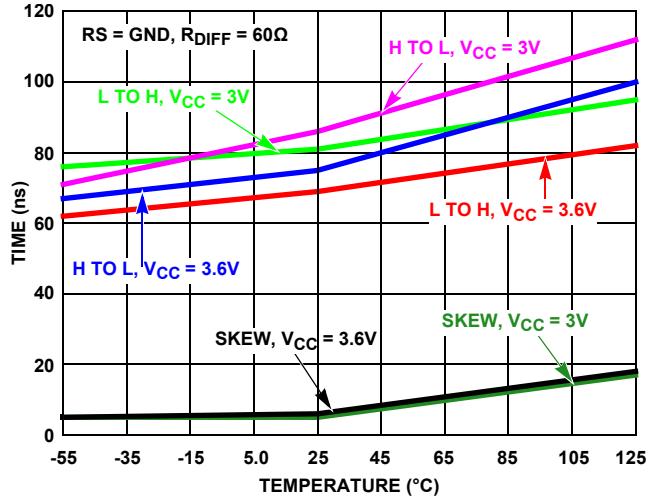

FIGURE 27. TRANSMITTER PROPAGATION DELAY AND SKEW vs TEMPERATURE AT FAST SPEED

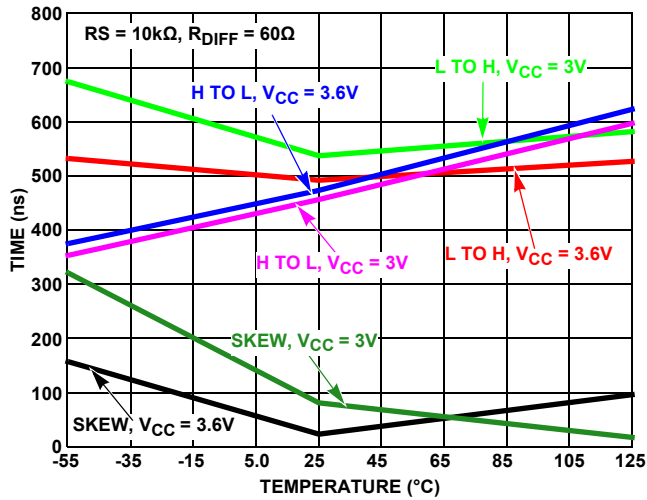

FIGURE 28. TRANSMITTER PROPAGATION DELAY AND SKEW vs TEMPERATURE AT MEDIUM SPEED

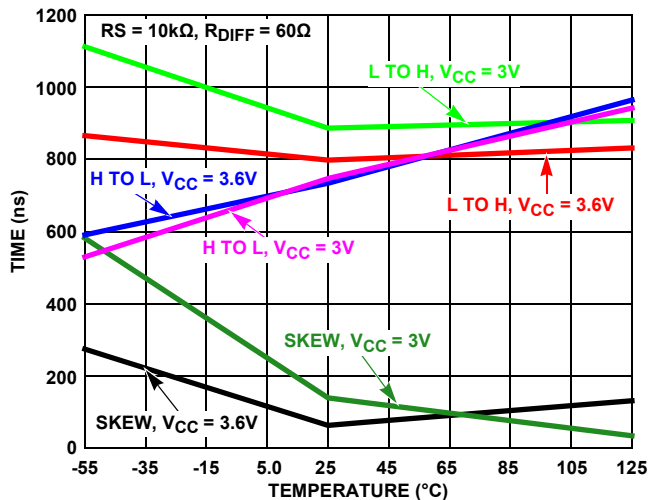

FIGURE 29. TRANSMITTER PROPAGATION DELAY AND SKEW vs TEMPERATURE AT SLOW SPEED

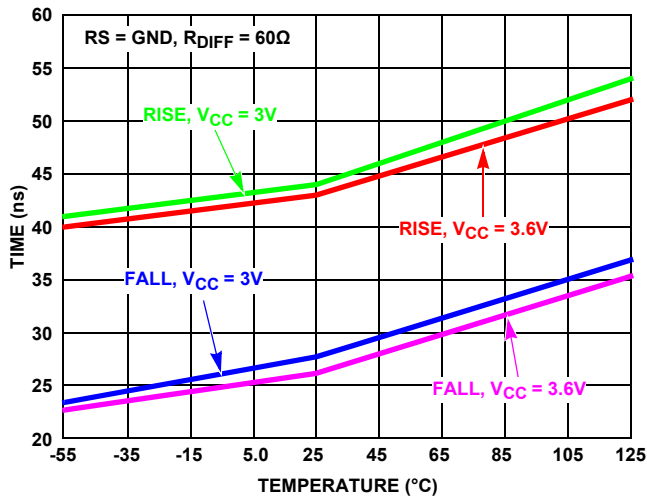

FIGURE 30. TRANSMITTER RISE AND FALL TIMES vs TEMPERATURE AT FAST SPEED

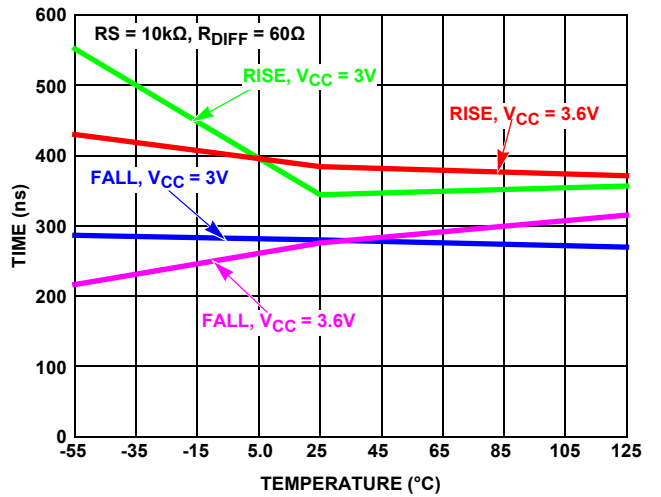

FIGURE 31. TRANSMITTER RISE AND FALL TIMES vs TEMPERATURE AT MEDIUM SPEED

Typical Performance Curves $V_{CC} = 3.3V, C_L = 15pF, T_A = +25^\circ C$; unless otherwise specified. (Continued)

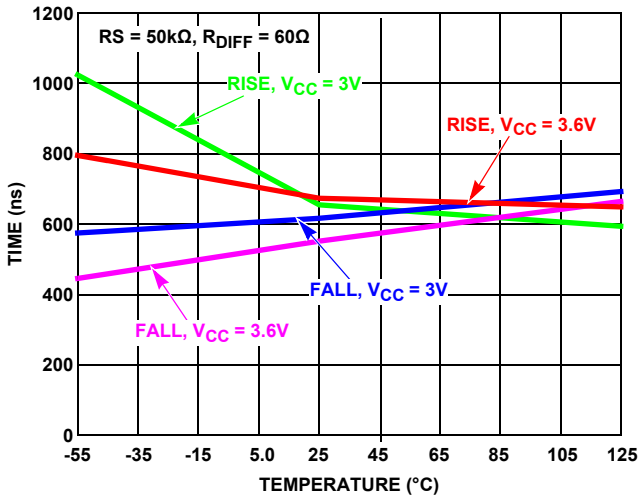

FIGURE 32. TRANSMITTER RISE AND FALL TIMES vs TEMPERATURE AT SLOW SPEED

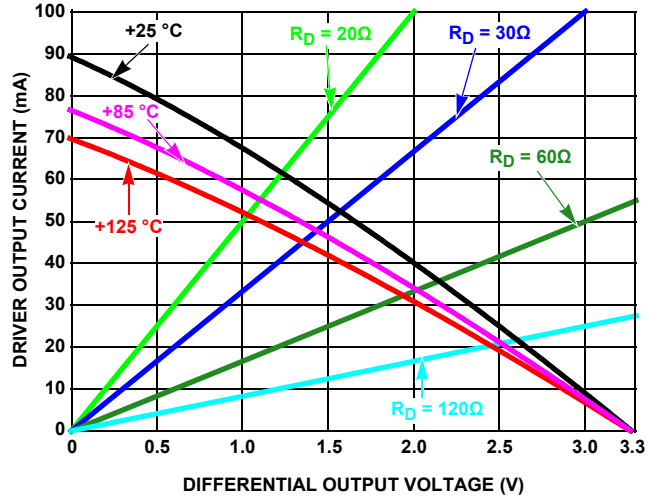

FIGURE 33. DRIVER OUTPUT CURRENT vs DIFFERENTIAL OUTPUT VOLTAGE

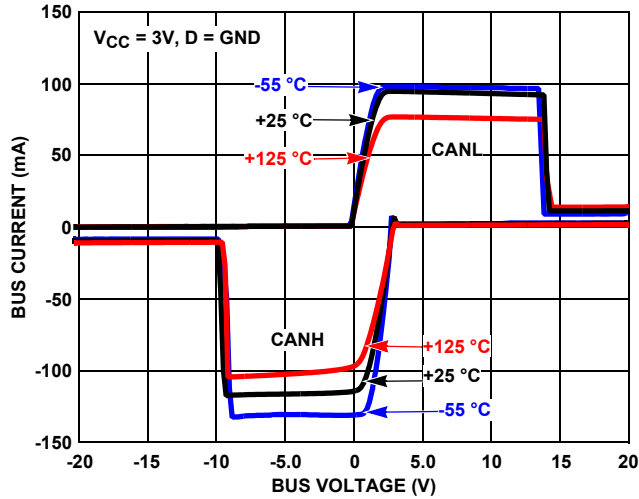

FIGURE 34. DRIVER OUTPUT CURRENT vs SHORT-CIRCUIT VOLTAGE vs TEMPERATURE

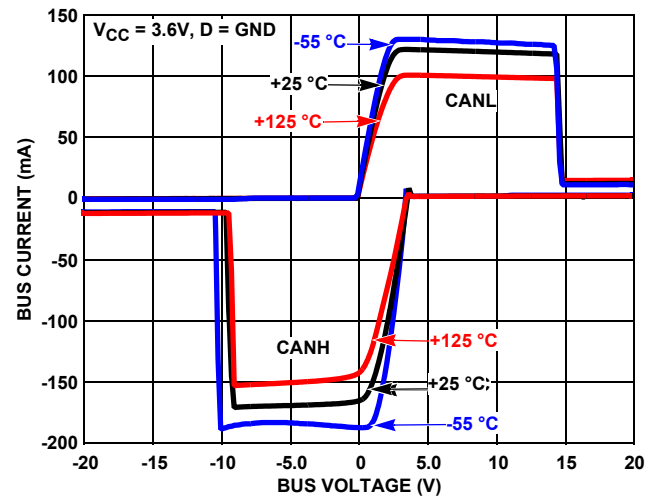

FIGURE 35. DRIVER OUTPUT CURRENT vs SHORT-CIRCUIT VOLTAGE vs TEMPERATURE

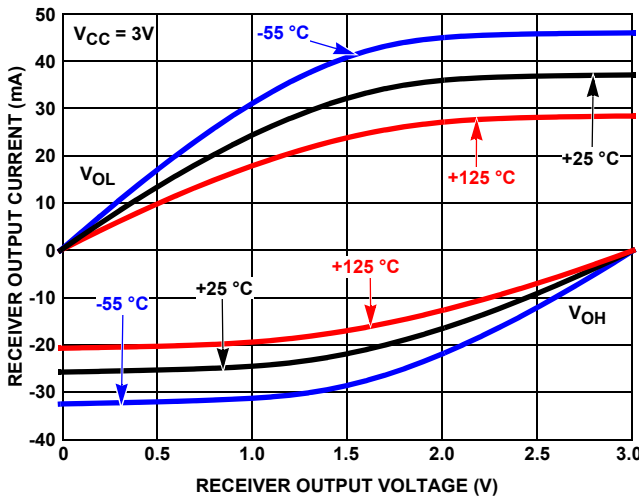

FIGURE 36. RECEIVER OUTPUT CURRENT vs RECEIVER OUTPUT VOLTAGE AT VCC = 3V

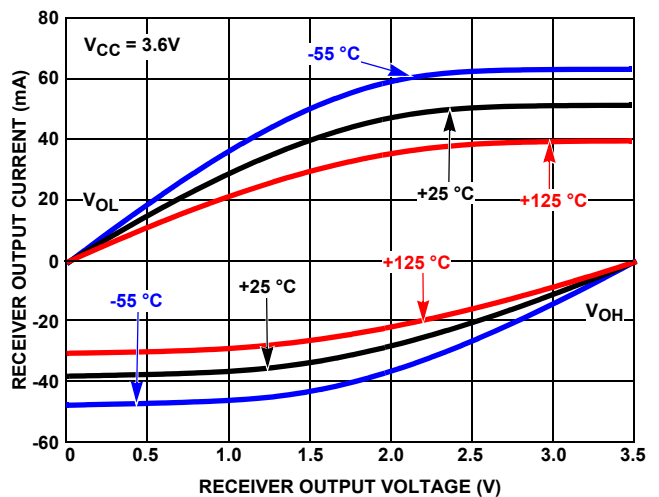

FIGURE 37. RECEIVER OUTPUT CURRENT vs RECEIVER OUTPUT VOLTAGE AT VCC = 3.6V

Typical Performance Curves $V_{CC} = 3.3V, C_L = 15pF, T_A = +25^\circ C$; unless otherwise specified. (Continued)

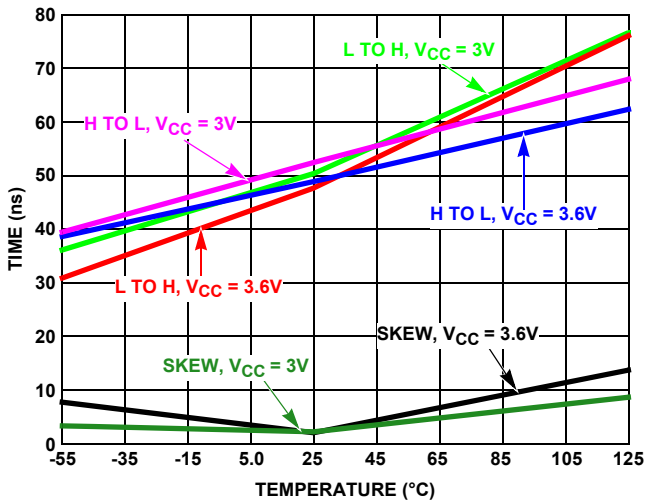

FIGURE 38. RECEIVER PROPAGATION DELAY AND SKEW vs TEMPERATURE

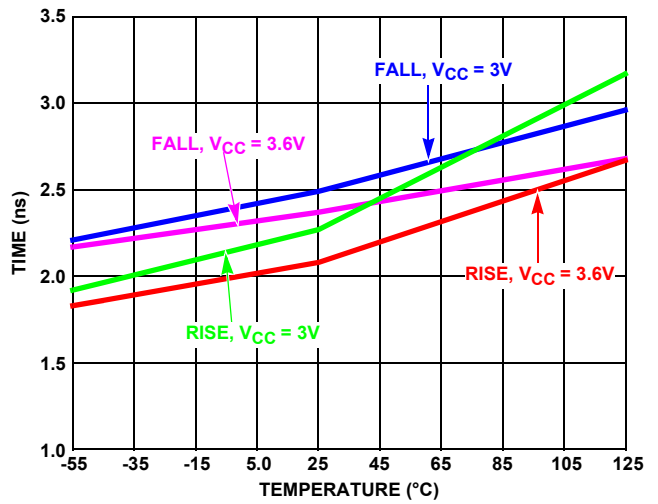

FIGURE 39. RECEIVER RISE AND FALL TIMES vs TEMPERATURE

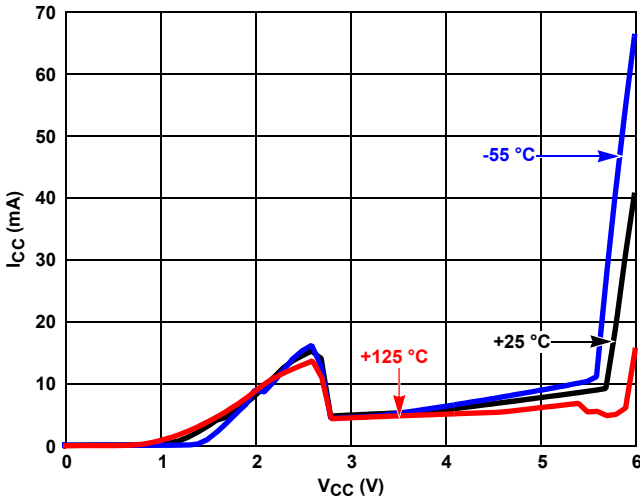

FIGURE 40. SUPPLY CURRENT vs SUPPLY VOLTAGE vs TEMPERATURE

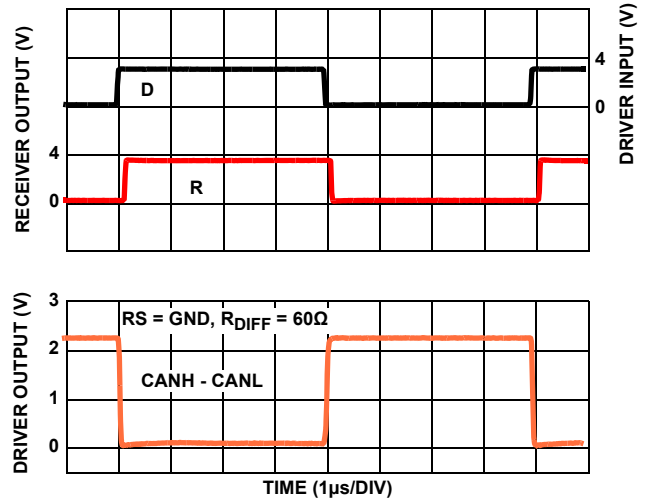

FIGURE 41. FAST DRIVER AND RECEIVER WAVEFORMS

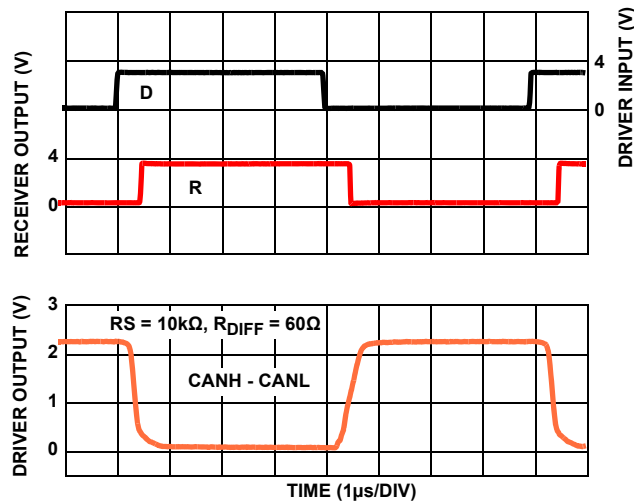

FIGURE 42. MEDIUM DRIVER AND RECEIVER WAVEFORMS

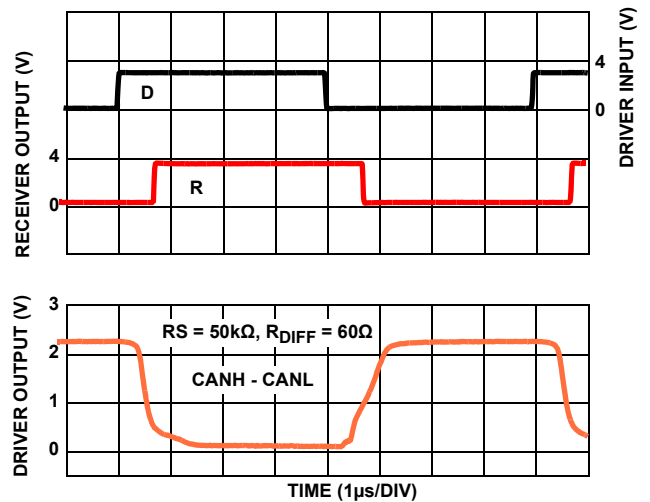

FIGURE 43. SLOW DRIVER AND RECEIVER WAVEFORMS

Die Characteristics

Die Dimensions

2413µm x 3322µm (95 mils x 130.79 mils)
 Thickness: 305µm ±25µm (12 mils ±1 mil)

Interface Materials

GLASSIVATION

Type: 12kÅ Silicon Nitride on 3kÅ Oxide

TOP METALLIZATION

Type: 300Å TiN on 2.8µm AlCu
 In Bondpads, TiN has been removed.

BACKSIDE FINISH

Silicon

PROCESS

P6SOI

Assembly Related Information

SUBSTRATE POTENTIAL

Floating

Additional Information

WORST CASE CURRENT DENSITY

$1.6 \times 10^5 \text{ A/cm}^2$

TRANSISTOR COUNT

4055

Weight of Packaged Device

0.31 grams

Lid Characteristics

Finish: Gold

Potential: Grounded, tied to package pin 2

Metalization Mask Layout

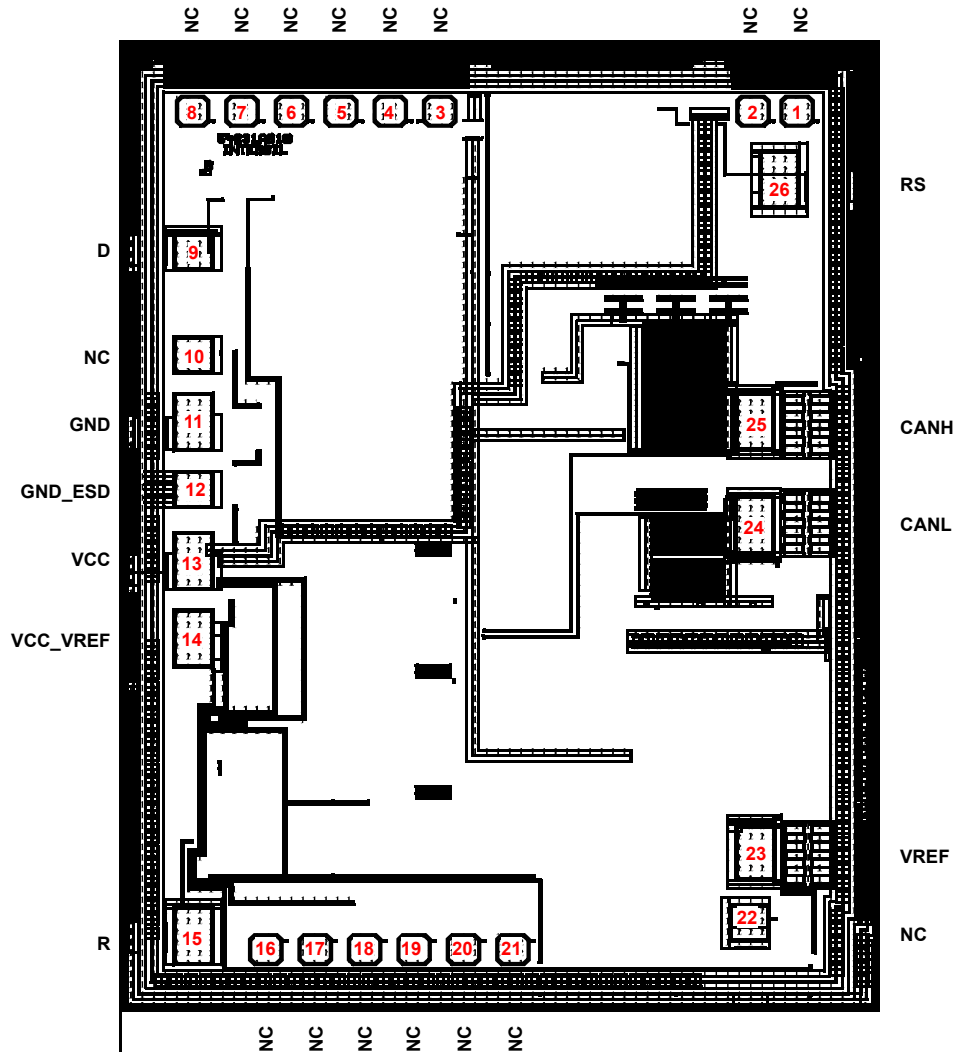

TABLE 2. ISL72027SEH DIE LAYOUT X-Y COORDINATES

PAD NUMBER	PAD NAME	X (μm)	Y (μm)	X	Y
1	NC	90.0	90.0	901.4	1365.6
2	NC	90.0	90.0	767.4	1365.6
3	NC	90.0	90.0	-183.23	1365.6
4	NC	90.0	90.0	-333.25	1365.6
5	NC	90.0	90.0	-483.25	1365.6
6	NC	90.0	90.0	-633.25	1365.6
7	NC	90.0	90.0	-783.25	1365.6
8	NC	90.0	90.0	-933.25	1365.6
9	D	110.0	110.0	-931.1	901.85
10	NC	110.0	110.0	-931.1	563.25
11	GND	110.0	180.0	-931.1	342.25
12	GND_ESD	110.0	110.05	-931.1	119.42
13	VCC	110.0	180.0	-931.1	-115.05
14	VCC_VREF	110.0	180.05	-931.1	-371.08
15	R	110.0	180.0	-931.1	-1350.0
16	NC	90.0	90.0	-711.1	-1394.95
17	NC	90.0	90.0	-561.1	-1394.95
18	NC	90.0	90.0	-411.1	-1394.95
19	NC	90.0	90.0	-261.1	-1394.95
20	NC	90.0	90.0	-111.1	-1394.95
21	NC	90.0	90.0	38.9	-1394.95
22	NC	110.0	110.0	756.9	-1307.3
23	VREF	110.0	180.0	775.3	-1072.3
24	CANL	110.0	180.0	772.1	2.15
25	CANH	110.0	180.05	772.1	343.33
26	RS	110.0	180.0	848.1	1140.6

NOTE: Origin of coordinates is the center of the die. NC - No Connect

Revision History The revision history provided is for informational purposes only and is believed to be accurate, but not warranted. Please go to the web to make sure that you have the latest revision.

DATE	REVISION	CHANGE
August 16, 2016	FN8763.3	"Absolute Maximum Ratings" on page 5 changed voltage value in VCC to GND With/Without Ion Beam From: -0.3V to 4.5V To: -0.3V to 5.5V.
April 29, 2016	FN8763.2	- Updated title. - Updated the test condition for Output Rise Time on page 7. - Changed maximum data rate from 1Mbps to 5Mbps in the following locations: - Second paragraph and "Features" section on page 1. - In "Overview" on page 11.
November 9, 2015	FN8763.1	Absolute Maximum Ratings table on page 5: changed the value for "CANH, CANL, VREF Under Ion Beam" from $\pm 16V$ to $\pm 18V$.
October 26, 2015	FN8763.0	Initial Release

About Intersil

Intersil Corporation is a leading provider of innovative power management and precision analog solutions. The company's products address some of the largest markets within the industrial and infrastructure, mobile computing and high-end consumer markets.

For the most updated datasheet, application notes, related documentation and related parts, please see the respective product information page found at www.intersil.com.

You may report errors or suggestions for improving this datasheet by visiting www.intersil.com/ask.

Reliability reports are also available from our website at www.intersil.com/support.

© Copyright Intersil Americas LLC 2015-2016. All Rights Reserved.
All trademarks and registered trademarks are the property of their respective owners.

For additional products, see www.intersil.com/en/products.html

Intersil products are manufactured, assembled and tested utilizing ISO9001 quality systems as noted in the quality certifications found at www.intersil.com/en/support/qualandreliability.html

Intersil products are sold by description only. Intersil may modify the circuit design and/or specifications of products at any time without notice, provided that such modification does not, in Intersil's sole judgment, affect the form, fit or function of the product. Accordingly, the reader is cautioned to verify that datasheets are current before placing orders. Information furnished by Intersil is believed to be accurate and reliable. However, no responsibility is assumed by Intersil or its subsidiaries for its use; nor for any infringements of patents or other rights of third parties which may result from its use. No license is granted by implication or otherwise under any patent or patent rights of Intersil or its subsidiaries.

For information regarding Intersil Corporation and its products, see www.intersil.com

Package Outline Drawing

K8.A

8 LEAD CERAMIC METAL SEAL FLATPACK PACKAGE

Rev 4, 12/14

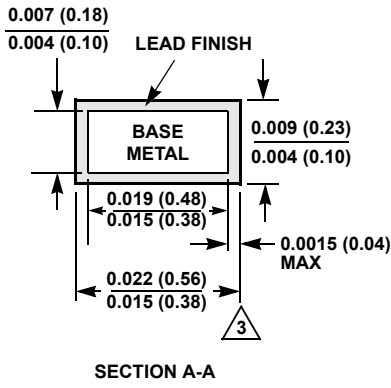
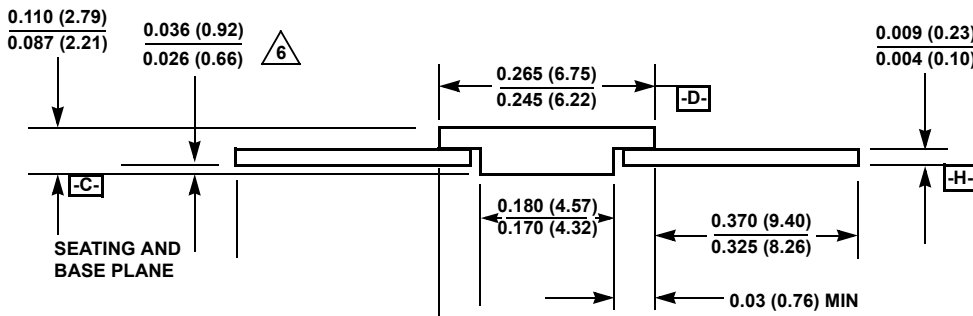
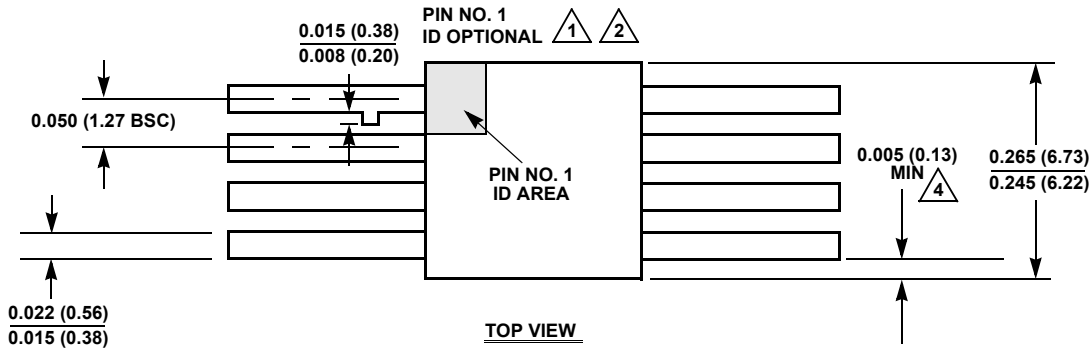

NOTES:

1. Index area: A notch or a pin one identification mark shall be located adjacent to pin one and shall be located within the shaded area shown. The manufacturer's identification shall not be used as a pin one identification mark. Alternately, a tab may be used to identify pin one.
2. If a pin one identification mark is used in addition to or instead of a tab, the limits of the tab dimension do not apply.
3. The maximum limits of lead dimensions (section A-A) shall be measured at the centroid of the finished lead surfaces, when solder dip or tin plate lead finish is applied.
4. Measure dimension at all four corners.
5. For bottom-brazed lead packages, no organic or polymeric materials shall be molded to the bottom of the package to cover the leads.
6. Dimension shall be measured at the point of exit (beyond the meniscus) of the lead from the body. Dimension minimum shall be reduced by 0.0015 inch (0.038mm) maximum when solder dip lead finish is applied.
7. Dimensioning and tolerancing per ANSI Y14.5M - 1982.
8. Controlling dimension: INCH.