

## AN-1198 Power Generator Protection through Differential Relay using GreenPAK™

The GreenPAK IC can be used for the protection of a 3-Phase Power Generator. In this application note, we will explain how to design the differential protection of a 3-Phase Power Generator. This design will help to protect the generator from internal faults, i.e. inter-turn faults, single-phase to ground faults, double line to ground fault, three-phase fault, etc. The six analog outputs from ground and line sides of 3-phase power generator will be monitored. The faults in between the boundaries (line side and ground side current transformers) of 3-phase generator are identified based on these currents.

### Problem Statement

It is necessary to protect a power generator properly due to its importance in a power system for electrical energy generation. The 3-phase power generator is the source of electrical energy in a typical power system. Different protection devices are designed to protect the power generator from these faults. If not protected properly, a great financial loss could occur because it is one of the most expensive units in the power system. Other circuits to protect the power generator are available, but the GreenPAK design will provide a less expensive and more reliable solution to this problem.

### Power Generator Background

A generator is a device that converts mechanical power into electrical power for use in an external circuit. Sources of mechanical energy include steam turbines, gas turbine, water turbines, internal combustion engine and even hand cranks. Each power generator generates voltages from 3.3 kV to 33 kV. The generators don't generate voltages below 3.3 kV because the proportionate current increase demands that the conductors have a very large diameter to handle that current. Also, they cannot generate voltages above 33 kV due to the increase in insulation strength requirement. The reason is that when voltage level increases, then insulation strength is also required to increase. After the location of each power generator in the power system, a step up transformer is attached to increase the voltage level to 120, 220, 500 kV for the transmission purpose. The reason for power transmission at high voltages is that the losses decrease at high voltages. To keep power constant, the current decreases at high voltages and hence the transmission line losses decrease. To calculate the power loss in any transmission line, the following mathematical formula is used.

$$P = I^2R$$

where,

$P$  = Copper power loss

$I$  = Current in the transmission lines

$R$  = Resistance of the transmission lines

For the particular power generator used in this application note, the lowest practical value for voltage is 3.3KV, and the highest voltage is 33KV. There are six sets of current transformers (CT), three CTs are connected to the line side of the generator and other three are connected to the ground side of the generator. Each phase has two CTs. It is needless to say that the characteristics of all current transformers installed against each phase must be matched. If there is any major mismatch in the current transformer's characteristics of both sides of the generator, there may be a high chance of malfunctioning of the differential relay during a fault external to the stator winding, and also may be during normal operating conditions of the generator. It is always preferable to use dedicated current transformers for differential protection purpose because

common current transformers may cause unequal secondary loading for other functionalities imposed on them. It is also always preferable to use all current transformers for differential protection of generators (or alternators) having same characteristics. However, practically there may be some difference in characteristics of the current transformers installed at line side to those installed on the neutral side of the generator. These mismatches cause spill current to flow through the relay operating coil. To avoid the effect of spill current, percentage biasing is introduced in the differential relay.

Differential current pickup setting/bias setting of the relay is adapted based on the maximum percentage of allowable mismatch adding some safety margin. The spill current level for the relay is to just operate it; is experienced as a percentage of the through fault current causing it. This percentage is defined as bias setting of the relay.

$$\text{Percentage bias} = \frac{\text{Spill current for relay operation}}{\text{Through fault current causing it}} \times 100\%$$

The power generator protection is shown in figure 1. It has 6 CTs, 3 are connected on ground side and the other 3 are connected on the line side of the generator. The currents from CTs have been taken and after balancing it through resistors it is given as an input to the differential relay. The current balancing has been done to avoid mismatching in the currents of both sides. There are different components inside of a relay, each of them used to detect different faults i.e. phase fault detection component, ground fault detection component, etc.

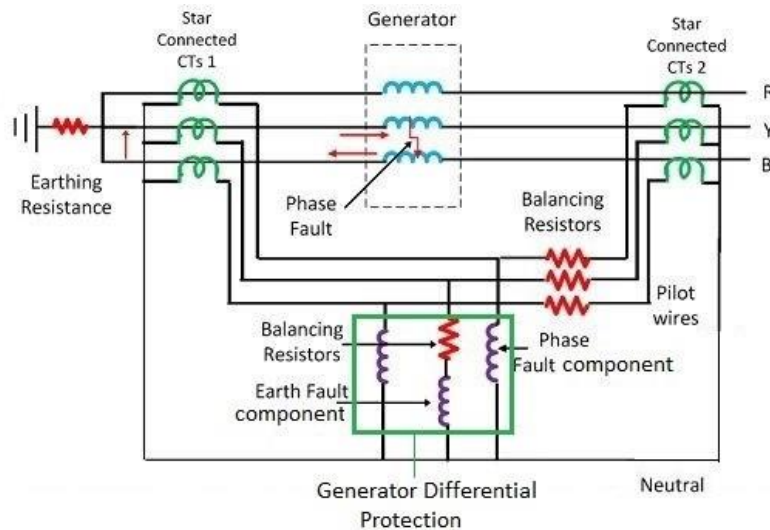

Figure 1. 3-Phase Power Generator Protection schematic

In the 3-phase system, each connection is either in Star (Y) connection, or Delta connection. The generator, transformer and load connections in the 3-phase power system are shown in figure 2. The generator zone boundary is also shown in figure 2.

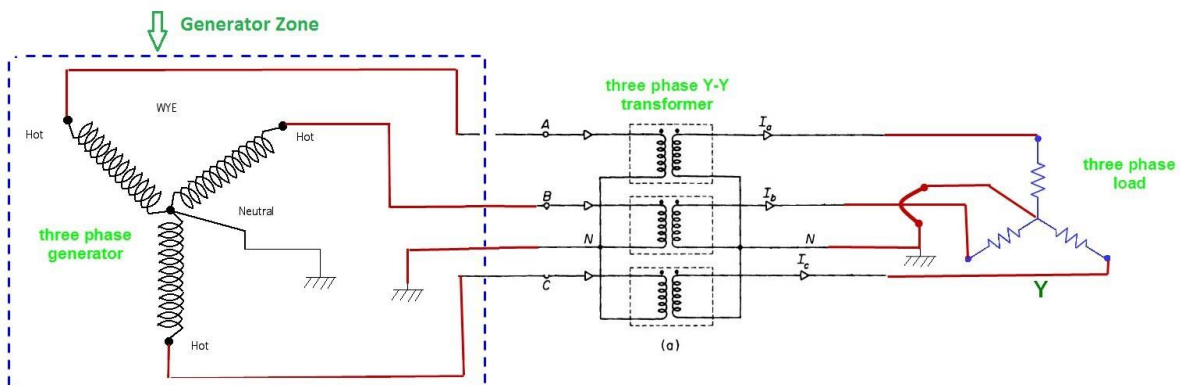

Figure 2. 3-Phase connection of Power Generator in Power System

The block diagram representation of power generator protection using a GreenPAK IC is shown in figure 3.

## Flow Diagram

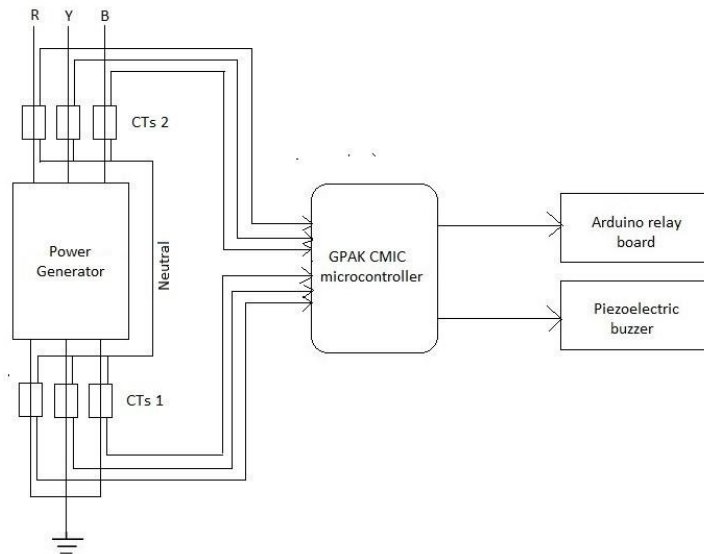

Figure 3. Block Diagram representation

There are six current transformers that are attached on the line and ground sides. Since we are considering three-phase power generation, each phase has two dedicated CTs connected to it. Phase A has CT1 and CT4, phase B has CT2 and CT5, and phase C has CT3 and CT6. We have considered CTs of 1A output current rating. There are certain practical mismatches that occur during this procedure i.e. CT burden class mismatch, CT accuracy class mismatch, CT current transformation mismatch, the length of cable used to transfer current from CT to relay, etc. Due to these mismatches, a margin of 0.2A has been used. Thus, each CT has been checked whether its output is greater than 1.2A or not. In case of no fault in each phase, the CT output is less than 1.2A. Thus, if the current is greater than 1.2A then there is fault in between the boundaries of the generator.

After checking whether the output of each CT is greater than 1.2A or not, an OR logic gate for each of the three phases is used. If the output logic of a particular OR logic gate is high then it means that there is a fault in that phase and vice versa. After that, the outputs from three phases have been sent to another Logic OR Gate. It makes the final decision. If its output is logic high, then a trip signal is sent to both the line side and ground sides and vice versa. The final logic gate output is sent to the HL-52S relay modules and piezoelectric buzzer. Relay modules are used to open the contacts of the generator from ground and line sides to isolate it from the power system. HL-52S relay module allows the power generator to remain in the system in order to provide voltages for the running of loads during normal conditions. The detailed flow diagram of this algorithm is shown in figure 4.

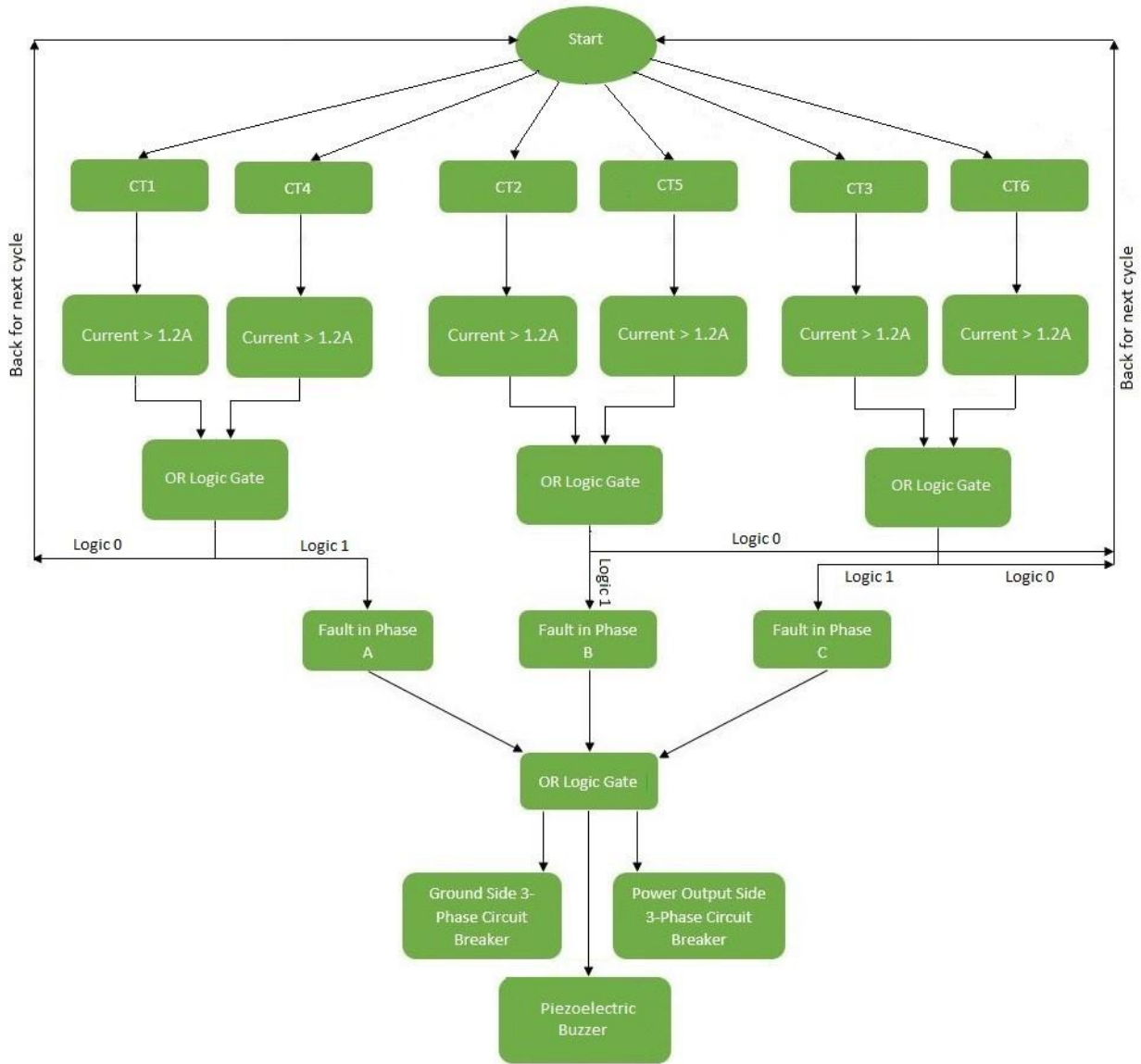

Figure 4. Flow diagram of Power Generator Protection

The algorithm is repeated again in the power generator protection scheme. The top-level schematic is shown in figure 5.

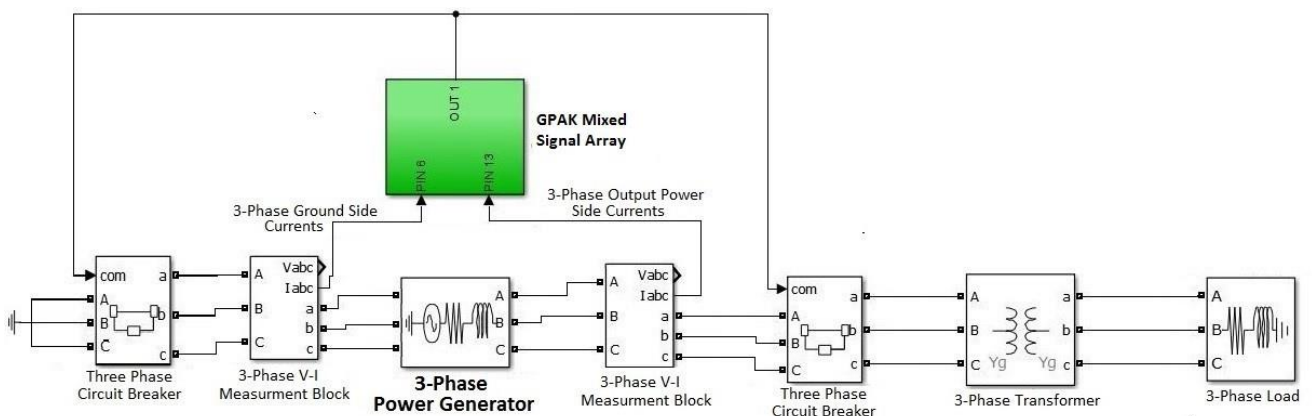

Figure 5. Top level Schematic

## Description

### Current Transformer

A current transformer is a type of transformer that is used to measure AC Current. It produces an alternating current (AC) in its secondary that is proportional to the AC current in its primary. Current transformers, together with voltage transformers (VTs) or potential transformers (PTs), which are designed for measurement, are known as an Instrument Transformer.

The main tasks of instrument transformers are:

- To transform currents from a usually high value to a value easy to handle for relays and instruments.
- To insulate the metering circuit from the primary high voltage system.
- To provide the possibility of standardizing the instruments and relays to a few rated currents and voltages.

When the current to be measured is too high to measure, a current transformer can be used to provide an isolated lower current in its secondary that is proportional to the current in the primary circuit. The induced secondary current is then suitable for measuring instruments or processing in electronic equipment. Current transformers have very little effect on the primary circuit. A CT is connected in series with the transmission line due to its very low input resistance.

Current transformers are the current sensing units of the power system. The outputs of current transformers are used in electronic equipment and are widely used for metering and protective relays in the electrical power industry.



Figure 6. Current Transformer

Most current transformers have the standard secondary rating of 5 or 1 amps with the primary and secondary currents being expressed as a ratio such as 100/5 or 100/1 respectively. This means that in the case of 100/5 CT, the primary current is 20 times greater than the secondary current so when 100 amps are flowing in the primary conductor it will result in 5 amps flowing in the secondary winding.

By increasing the number of secondary windings ( $N_2$ ), the secondary current can be made much smaller than the current in the primary circuit being measured because as  $N_2$  increases,  $I_2$  goes down by a proportional amount. In other words, the number of turns and the current in the primary and secondary windings are related by an inverse proportion.

A current transformer, like any other transformer, must satisfy the amp-turn equation and this turns ratio is equal to:

$$\text{Turn Ratio} = n = \frac{N_p}{N_s} = \frac{I_s}{I_p}$$

From which we get:

$$I_s = \frac{N_p}{N_s} \times I_p$$

where,

$N_p$  = Number of turns in the primary windings

$N_s$  = Number of turns in the secondary windings

$I_p$  = Current in the primary windings

$I_s$  = Current in the secondary windings

The current ratio will set the turns ratio and as the primary usually consists of one or two turns, while the secondary can have several hundred turns, the ratio between the primary and secondary can be quite large. For example, assume that the current rating of the primary winding is 100A. The secondary winding has the standard rating of 5A. The ratio between the primary and the secondary currents is 100A-to-5A, or 20:1. In other words, the primary current is 20 times greater than the secondary current.

### HL-52S Relay Module

The HL-52S Relay module allows a wide range of control for larger loads and devices like AC or DC Motors, electromagnets, solenoids, and incandescent light bulbs. The relay shield uses one QIANJI JQC-3F high-quality relay with rated load 10A/250V AC, 10A/125V AC, 10A/28V DC, 10A/30V DC. The relay output state is individually indicated by a light-emitting diode.

The features of the module are given below.

- Control signal: TTL level
- Rated load: 10A/250V AC, 10A/125V AC, 10A/28V DC, 10A/30V DC
- Contact action time: 10ms/5ms
- COM- Common pin
- INT 1-4: Relay 1-4 control port
- NC- Normally Closed, in which case NC is connected with COM when INT1 is set low and disconnected when INT1 is high
- NO- Normally Open, in which case NO is disconnected with COM1 when INT1 is set low and connected when INT1 is high

We will use the HL-52S 2 channel relay module. The high voltage output connector has 3 pins, the middle one is the common pin, and as we can see from the markings one of the two other pins is for normally open connection and the other one for normally closed connection. The relay module is shown in figure 7. Its output contacts are normally open. They become closed when a logic high is applied at IN1 or IN2.

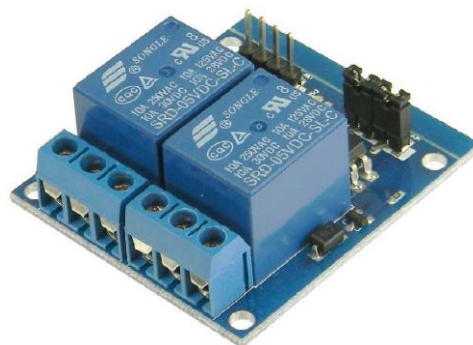

Figure 7. HL-52S Relay Module

On the other side of the module, we have these 2 sets of pins. The first one has 4 pins: a ground, a VCC pin for powering the module, and 2 input pins In1 and In2. The second set of pins has 3 pins with a jumper between the JDVcc and the Vcc pin.

## GreenPAK Design

The SLG46621V GreenPAK IC has been used to design the 3-phase power generator protection algorithm in GreenPAK software. There are six inputs that have been taken from the line side and ground side of the power generator using the current transformers. The block diagram representation of GreenPAK design is shown in Fig 8.

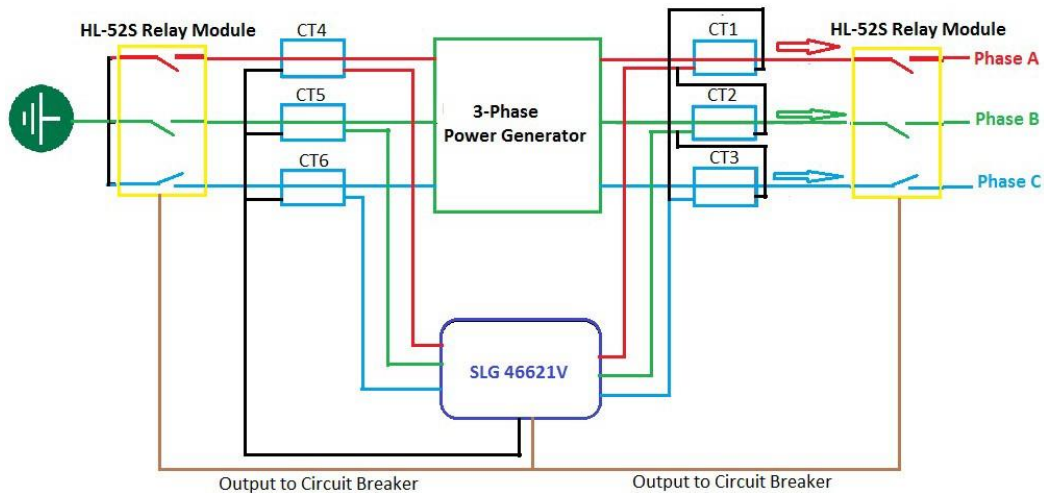

Figure 8. Block diagram of GreenPAK design

In matrix 0 of the GreenPAK design, for phase A, the outputs from CT1 and CT4 have been processed to check whether the current in each case is greater than 1.2A or not. If it is greater than 1.2A then a high logic level is sent to the look up table, otherwise a low is sent to the look up table. The look up table is an OR gate. Moreover, the output of the OR gate is then sent to an output pin P1. In matrix 1, the same procedure is applied for phase B (CT2 and CT5) and phase C (CT3 and CT6). The results from each phase are then fed to a three input OR gate. The output of that OR gate is then connected to the HL-52S relay modules that are connected to ground and line sides of the generator. The relay module contacts remain open when a low logic is applied at its digital input, but when a logic high is applied to its input terminals then its output terminals are closed. Thus, the generator supplies power to the load when a logic high is applied at IN1 (Closed circuit) and it is taken out of power system (Open circuit) when a logic low is applied at IN1. An inverter between each relay module and OR gate output has been used to achieve this logic. The HL-52S module opens its contacts during fault conditions. The OR gate output is also connected to the piezoelectric buzzer for the indication of alarm during fault conditions. The GreenPAK design schematic is shown in figures 9, 10.

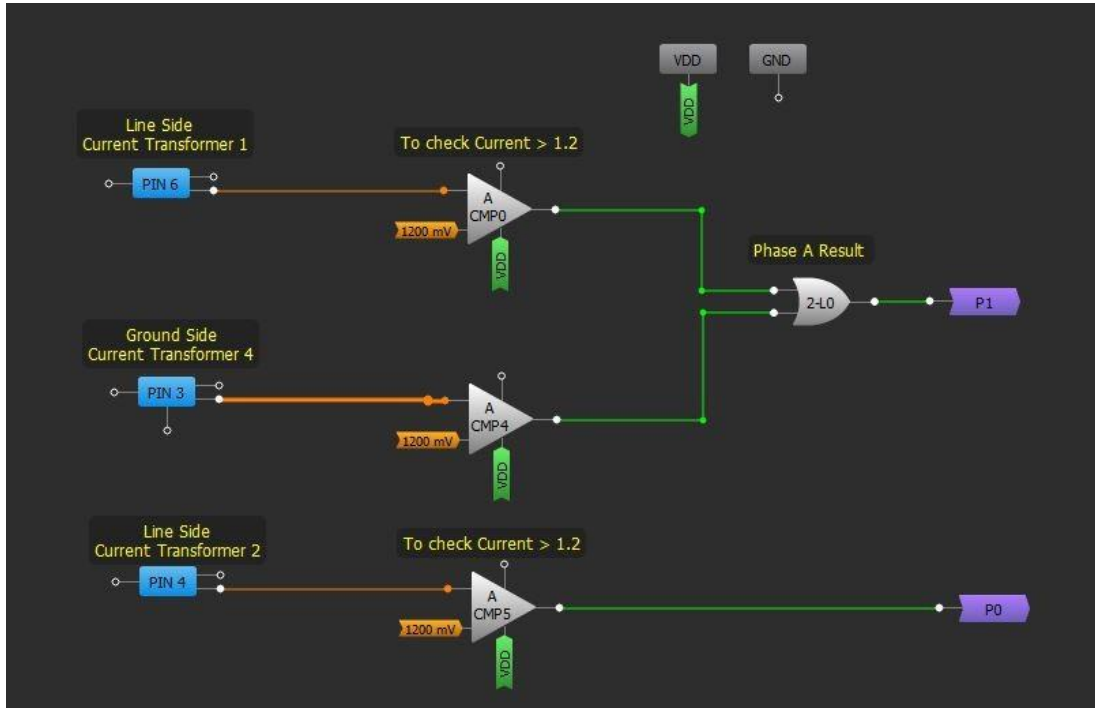

Figure 9. Power Generator Protection (Matrix 0)

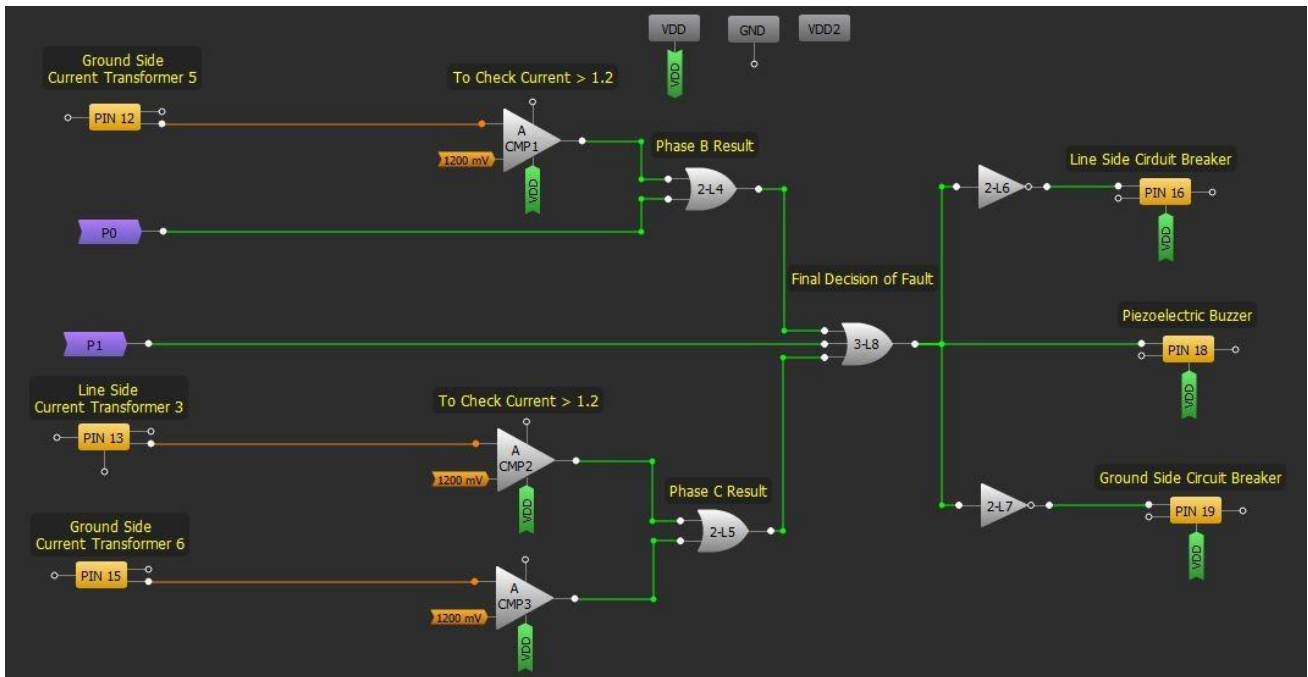

Figure 10. Power Generator Protection (Matrix 1)

There are three different cases that arise in the protection of 3-phase power generator and they are discussed below.



## Case No. 1: No fault

Figures 11 and 12 represent the no fault situation.

## Case No.2: External fault

When an external fault, beyond the line and ground side CTs is added, the 3-phase current and voltage waveforms are shown in figures 13, 14, 15, and 16. It can be observed that the power generator protection is insensitive to external faults i.e. it does not provide any trip signal to the circuit breaker.

## Case No.3: Internal Fault

When an internal fault between the ground and line side CTs is added, the 3-phase current and voltage waveforms are shown in figures 17, 18, 19, and 20. When an internal fault occurred, the current difference is greater than 0.2 and the relay energized. The generator has been taken out of power system. Thus, the voltage and current waveforms are zero in this case.

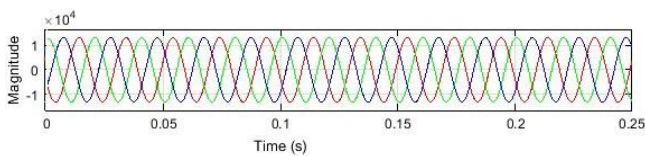

Figure 11. Ground side three phase voltages for No-Fault

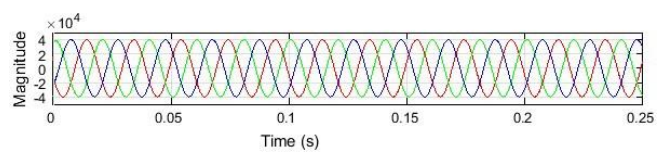

Figure 12. Line side three phase voltages for No-Fault

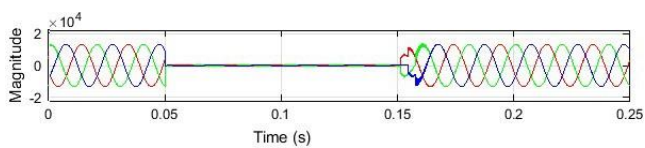

Figure 13. Ground side three phase voltages for External Fault

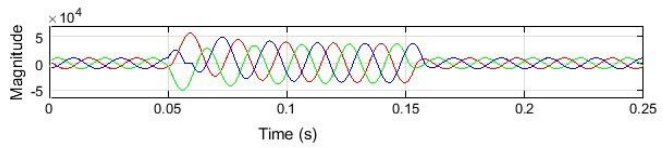

Figure 14. Ground side three phase currents for External Fault

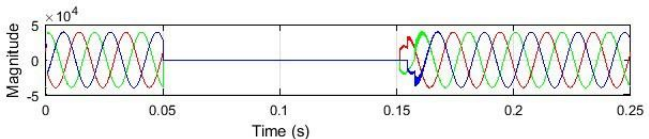

Figure 15. Line Side three phase voltages for External Fault

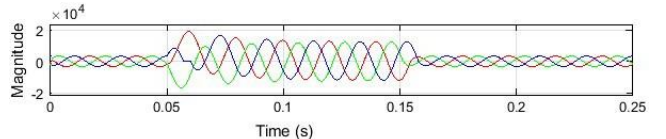

Figure 16. Line Side three phase currents for External Fault

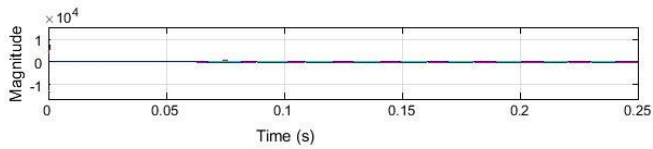

Figure 17. Ground Side three phase voltages for Internal Fault



Figure 18. Ground Side three phase currents for Internal Fault

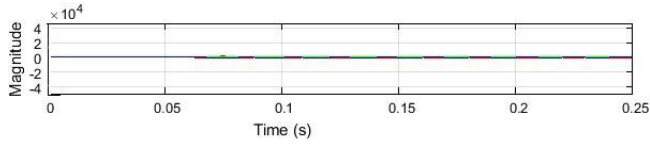

Figure 19. Line Side three phase voltages for Internal Fault

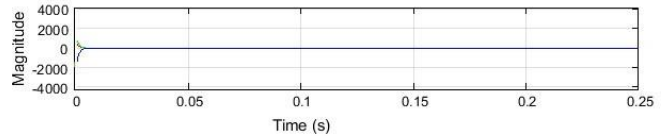

Figure 20. Line Side three phase currents for Internal Fault

## Conclusion

In this application note, we designed the 3-phase power generator protection scheme using the GreenPAK SLG46621V as the main controlling element. The designed algorithm is smart enough to detect and isolate the power generator from the power system during fault conditions. It allows the generator to remain in the power system when there is no fault. The design can be further improved by adding backup protection schemes. The backup protection of a power generator could include overcurrent relay, low forward power protection, reverse power protection, and pole slip protection.

## IMPORTANT NOTICE AND DISCLAIMER

RENESAS ELECTRONICS CORPORATION AND ITS SUBSIDIARIES (“RENESAS”) PROVIDES TECHNICAL SPECIFICATIONS AND RELIABILITY DATA (INCLUDING DATASHEETS), DESIGN RESOURCES (INCLUDING REFERENCE DESIGNS), APPLICATION OR OTHER DESIGN ADVICE, WEB TOOLS, SAFETY INFORMATION, AND OTHER RESOURCES “AS IS” AND WITH ALL FAULTS, AND DISCLAIMS ALL WARRANTIES, EXPRESS OR IMPLIED, INCLUDING, WITHOUT LIMITATION, ANY IMPLIED WARRANTIES OF MERCHANTABILITY, FITNESS FOR A PARTICULAR PURPOSE, OR NON-INFRINGEMENT OF THIRD PARTY INTELLECTUAL PROPERTY RIGHTS.

These resources are intended for developers skilled in the art designing with Renesas products. You are solely responsible for (1) selecting the appropriate products for your application, (2) designing, validating, and testing your application, and (3) ensuring your application meets applicable standards, and any other safety, security, or other requirements. These resources are subject to change without notice. Renesas grants you permission to use these resources only for development of an application that uses Renesas products. Other reproduction or use of these resources is strictly prohibited. No license is granted to any other Renesas intellectual property or to any third party intellectual property. Renesas disclaims responsibility for, and you will fully indemnify Renesas and its representatives against, any claims, damages, costs, losses, or liabilities arising out of your use of these resources. Renesas' products are provided only subject to Renesas' Terms and Conditions of Sale or other applicable terms agreed to in writing. No use of any Renesas resources expands or otherwise alters any applicable warranties or warranty disclaimers for these products.

(Rev.1.0 Mar 2020)

### Corporate Headquarters

TOYOSU FORESIA, 3-2-24 Toyosu,  
Koto-ku, Tokyo 135-0061, Japan  
[www.renesas.com](http://www.renesas.com)

### Contact Information

For further information on a product, technology, the most up-to-date version of a document, or your nearest sales office, please visit:  
[www.renesas.com/contact/](http://www.renesas.com/contact/)

### Trademarks

Renesas and the Renesas logo are trademarks of Renesas Electronics Corporation. All trademarks and registered trademarks are the property of their respective owners.