

AN-1151 Solar Powered Smart Street Lamp

This application note describes the design of a solar powered smart street lamp using GreenPAK™ IC. Street lamps are important because they illuminate humans, animals and obstructions that lie outside the coverage of car headlights. A solar powered street lamp is novel because it can be off-grid and still functioning in case of power outages. It also leaves power to be available for other purposes. It automatically illuminates when needed, and the resulting power savings earn it a “smart” designation.

Design Description

For this project GreenPAK SLG46140V IC has been used. With that, the three key features designed in are:

1. Motion Sensing
2. Daylight Presence Sensing
3. Battery Level Sensing

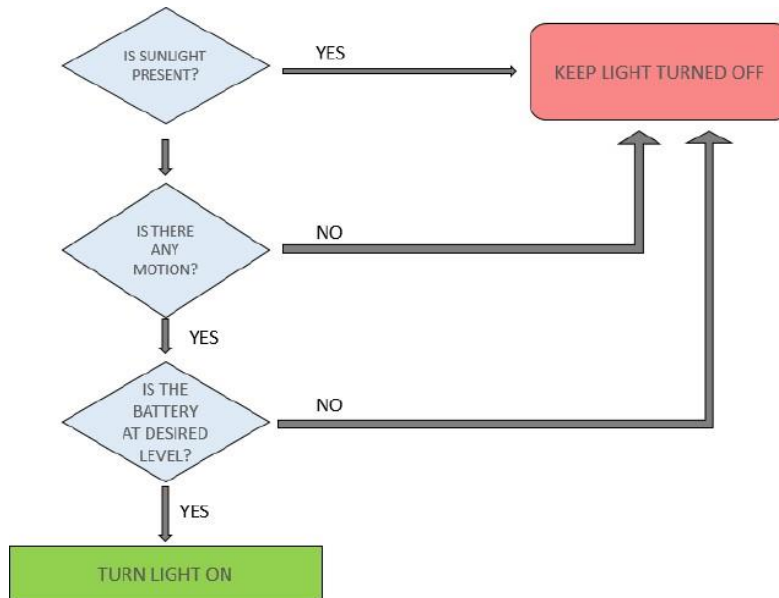

Figure 1. Flow Chart Describing Design

Motion Sensing

For power savings, the light is only allowed to turn when it detects presence of any moving body. To accomplish this, a Passive Infra-Red (PIR) Sensor has been designed in. This PIR Motion sensor has a single output pin along with pins for VCC and GND. A PIR sensor basically detects levels of Infrared Radiation. As soon as it detects a change in the levels of radiation, it sends out a signal notifying of the change. This sensor is one of the most commonly used for the purpose of motion detection. (see Fig. 2).



Figure 2. PIR Motion Sensor

Ambient Daylight Sensing

The solar panel itself is used to sense ambient light. A solar panel gives full output in full direct sunlight, and zero output with no light. These conditions can then be converted to produce appropriate levels to a digital input pin of the IC. By using a simple voltage divider circuit, the 18 volts generated by the solar panel can be converted to become a 3.3V signal that will represent a High-Level logic input for the SLG46140V GreenPAK IC.

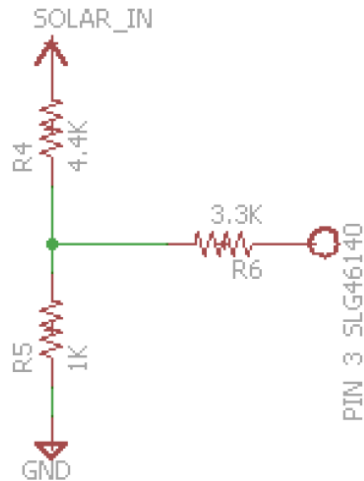

Figure 3. Converting higher voltages to lower GreenPAK IC acceptable Digital Signal

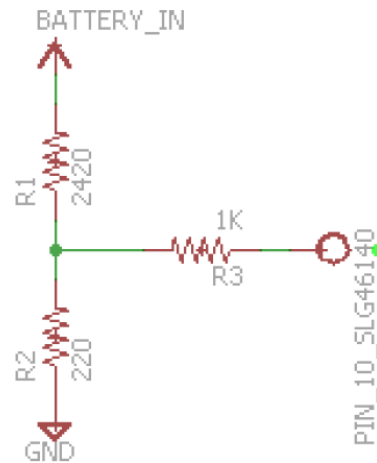

Figure 4. Battery Level Converter

Battery Level Monitoring and Charging

Battery level monitoring is also an important aspect of this system. In this design a Sealed Lead-Acid (SLA) Battery has been used. SLA Batteries are very versatile, dependable and cost-effective batteries. Charging methods of SLA Batteries are much simpler compared to batteries with other chemistry. SLA batteries need to be charged at a constant current equal to $0.1C$ (here C = the capacity of a battery at fully charged scale, Ampere-hour) and a voltage of around 1.5Volts to 2 Volts higher than the rated output voltage. Because of this, the charging circuitry can also be simpler.

It is important to note that at full capacity a 12v SLA battery will give an open circuit voltage of around 13.2 volts. When discharged, the battery gives an open circuit voltage measuring a little less than 12v.

But since our IC cannot measure such high voltages, these need to be converted down to acceptable ranges.

Again a simple voltage divider is employed to divide down the voltages to around 800mv to represent a discharged battery and around 1150mv to represent a completely charged battery.

These voltage levels are then fed into the SLG46140V IC and compared using its Analog Comparators. As we will see in the next section, these comparators play a vital role in the overall project realization.

GreenPAK IC Design Description

The GreenPAK schematic to implement this design is shown in Fig. 5.

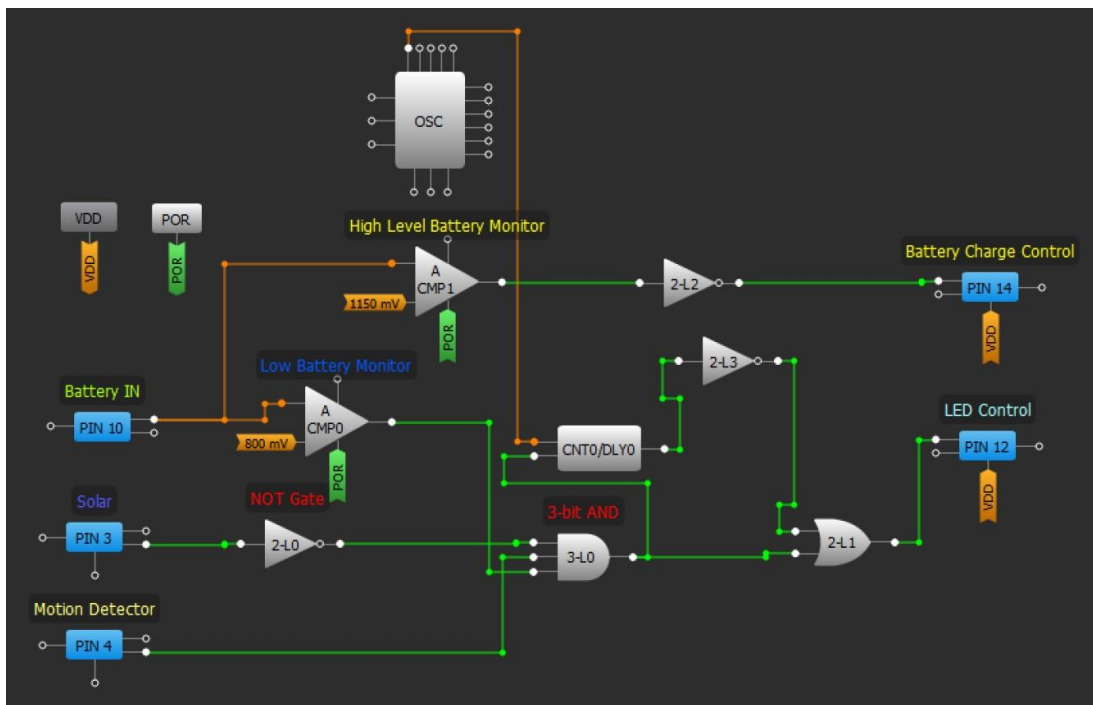

Figure 5. GreenPAK IC Design

Description of Pins Used:

- *PIN3*: Digital Input pin for detection of presence of ambient light.
- *PIN4*: Digital Input pin for detection of presence of motion or an object.
- *PIN10*: Analog Input Pin for battery level monitoring.
- *PIN12*: Digital Output with 1xPush-Pull Output Mode for controlling the LED.
- *PIN14*: Digital Output with 1xPush-Pull Output Mode for controlling the charge flow into the battery.

3 – Bit AND Gate:

The 3-bit AND Gate in this design ensures the light is turned ON only when all the conditions are met. Conditions such as *Detection of Motion in the vicinity, Ambient Sunlight presence & Desired Battery Level* are the three bits that determine the output of the AND Gate.

Sunlight	Motion	Battery Level (1 when $V_{battery} \Rightarrow 12V$)	Output
0	0	0	0
0	0	1	0
0	1	0	0
0	1	1	0
1	1	1	1

Table 1. 3-Bit AND Gate Truth Table (shortened)

Battery Level Monitoring:

Two analog comparators (ACMP0 and ACMP1) monitor the battery voltage. As described earlier, two voltage levels of 800mV and 1150mV have been used to determine the state of the battery. If the measured battery voltage drops to 800mV or less, the comparator (ACMP0) gives an output of zero. This output is fed into the 3-input AND Gate which in turn gives an output of zero as well turning the light OFF on detection of a low battery voltage level.

The High Level voltage is measured during charging and the divided down voltage taken as input to Pin10 of the IC is fed into the comparator (ACMP1). As soon the voltage level reaches or exceeds the reference voltage set on the inverting input (1150mV in this case), the comparator outputs a high. As soon as our desired level is reached we need to cutoff battery charging, hence a Low-level Output is required and a simple Inverter is employed for this purpose.

Input from the Solar Cell:

As described earlier, when there is no ambient light present, the solar cell gives an output of zero/Digital-Low signal. Since absence of sunlight is one of the conditions for turning our Street Lamp ON, we need to convert it into a Digital-High so that our AND Gate also outputs a HIGH. Hence, an Inverter is used here as well for that purpose.

Usage of Counter as means of extending Output Period:

In the above design a Counter(CNT0/DLY0) is also used to produce a certain amount of delay in turning off the signal at PIN12 of the GreenPAK IC. This creates a desired delay that avoids rapid output switching. (see Fig. 6)

WS Ctrl/14-bit CNT0/DLY0	
Type:	CNT/DLY
Mode:	Counter
Counter data:	8714
	(Range: 1 - 16383)
Output period (typical):	5 s Formula
Edge select:	Falling
Counter value control:	Reset (counter valu
DFF bypass enable:	None
Connections	
FSM data:	None
Clock:	LF OSC CLK
Clock source:	LF OSC Freq.
Clock frequency:	1.743 kHz

Figure 6. Counter Data

Description of External Circuits

This section describes the use of external circuitry that was needed to drive larger loads such as the 10W LED lamp, and the battery charging. To create the most efficient and energy saving circuits, MOSFETs have been used as opposed to normal BJTs. This results in faster switching time as well improved/reduced power consumption.

Battery Charging Control:

An IRLZ44N HEXFET POWER MOSFET(similar MOSFETs such as FQP30N06L can also be used) has been used which is an N-channel Enhancement Type MOSFET.

This MOSFET is specifically designed to operate with gate voltage levels (3V and 5V) that can be easily generated by small controllers and integrated circuits.

The datasheet of the MOSFET describes Threshold Gate to Source Voltage ($V_{gs(th)}$) of around 3 volts for a Drain Current I_D of around 1 Amperes. This can be easily achieved by our small GreenPAK IC according to the electrical specification table for Pin 12 (similar to PIN14).

LED Lamp Control:

Similar to the charging control circuit, this part of our project also uses a IRLZ44N HEXFET MOSFET for switching a 10 Watt LED which is the main source of illumination. Since we want to control a 10Watt LED with a 12V battery, we need to be able to supply a current of approx. 0.8 Amp. The circuit is shown in figure 8.

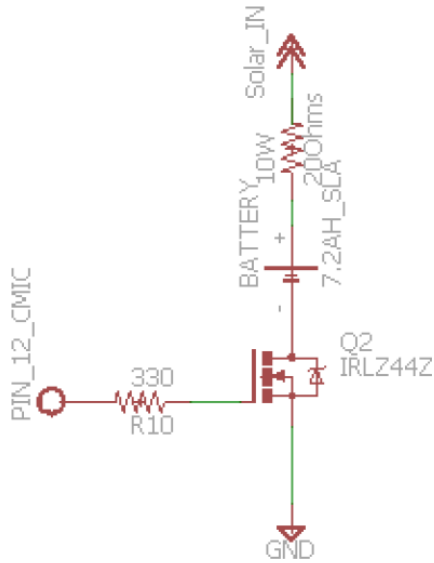

Figure 7. Battery Charge Control

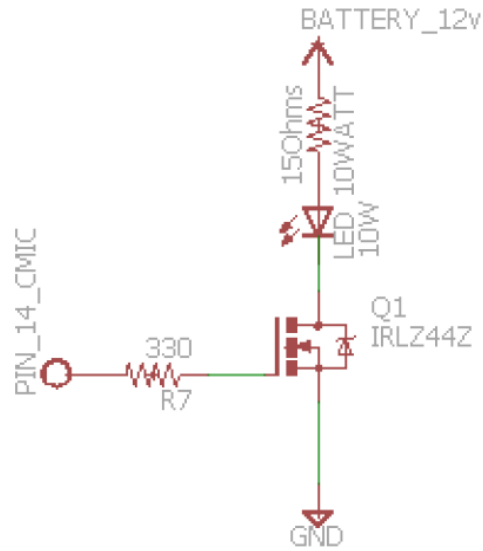

Figure 8. Schematic for controlling 10W LED

PIN 14			
Electrical Specifications			
	1.8 V min/max	3.3 V min/max	5.0 V min/max
V _{OH} (V)	1.670/-	2.722/-	4.168/-
V _{OL} (V)	-/0.020	-/0.280	-/0.330
I _{OH} (mA)	1.053/-	5.770/-	20.716/-
I _{OL} (mA)	0.760/-	4.060/-	6.010/-
-	-/-	-/-	-/-
-	-/-	-/-	-/-

Table 2. Electrical Specifications at PIN14

Application Examples of this Design

This application note describes the basic design that can be used to power any type of light efficiently and hassle free using solar power and a battery. This design can be scaled to larger power lights such as lighting used for infrastructure illumination to very small lights such as the ones used to beautify and illuminate paths, landscapes and horticulture as well. The design of the GreenPAK will remain similar for all of these applications.

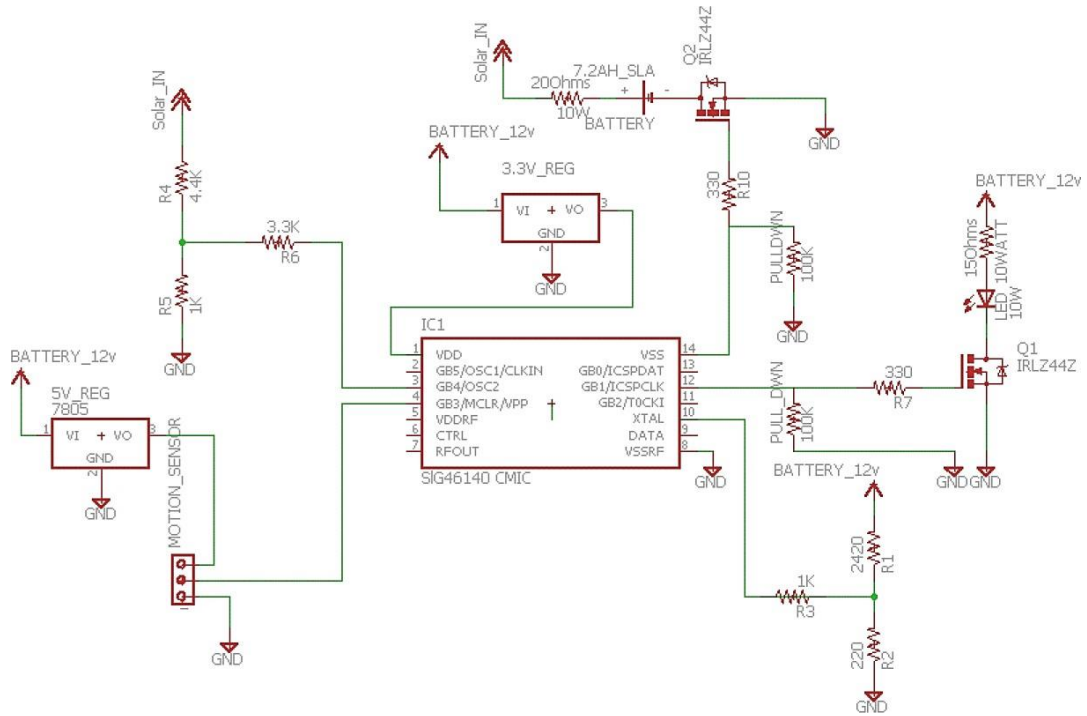

Figure 9. Top Level Schematic

Conclusion

In this application note, design of a smart street lamp was proposed using the SLG46140V GreenPAK IC as the main controlling element. The small sized IC proved to be immensely capable at performing the task at hand while also minimizing power consumption. The provision of proper design tools also aided very effectively in the process of realization of this project. This project can also be enhanced by introducing other circuitry such as detection of dust on the Solar Panel, or an external over-ride switch to latch the LED output.

IMPORTANT NOTICE AND DISCLAIMER

RENESAS ELECTRONICS CORPORATION AND ITS SUBSIDIARIES (“RENESAS”) PROVIDES TECHNICAL SPECIFICATIONS AND RELIABILITY DATA (INCLUDING DATASHEETS), DESIGN RESOURCES (INCLUDING REFERENCE DESIGNS), APPLICATION OR OTHER DESIGN ADVICE, WEB TOOLS, SAFETY INFORMATION, AND OTHER RESOURCES “AS IS” AND WITH ALL FAULTS, AND DISCLAIMS ALL WARRANTIES, EXPRESS OR IMPLIED, INCLUDING, WITHOUT LIMITATION, ANY IMPLIED WARRANTIES OF MERCHANTABILITY, FITNESS FOR A PARTICULAR PURPOSE, OR NON-INFRINGEMENT OF THIRD-PARTY INTELLECTUAL PROPERTY RIGHTS.

These resources are intended for developers who are designing with Renesas products. You are solely responsible for (1) selecting the appropriate products for your application, (2) designing, validating, and testing your application, and (3) ensuring your application meets applicable standards, and any other safety, security, or other requirements. These resources are subject to change without notice. Renesas grants you permission to use these resources only to develop an application that uses Renesas products. Other reproduction or use of these resources is strictly prohibited. No license is granted to any other Renesas intellectual property or to any third-party intellectual property. Renesas disclaims responsibility for, and you will fully indemnify Renesas and its representatives against, any claims, damages, costs, losses, or liabilities arising from your use of these resources. Renesas' products are provided only subject to Renesas' Terms and Conditions of Sale or other applicable terms agreed to in writing. No use of any Renesas resources expands or otherwise alters any applicable warranties or warranty disclaimers for these products.

(Disclaimer Rev.1.01 Jan 2024)

Corporate Headquarters

TOYOSU FORESIA, 3-2-24 Toyosu,
Koto-ku, Tokyo 135-0061, Japan
www.renesas.com

Trademarks

Renesas and the Renesas logo are trademarks of Renesas Electronics Corporation. All trademarks and registered trademarks are the property of their respective owners.

Contact Information

For further information on a product, technology, the most up-to-date version of a document, or your nearest sales office, please visit www.renesas.com/contact-us/.