

## Building an Accurate SPICE Model for Low Noise, Low Power Precision Amplifiers

### Abstract

In today's fast moving competitive markets, more and more customers are requesting SPICE models to run comprehensive circuit simulations. System engineers are requiring increasingly accurate models for all types of integrated circuits. Earlier SPICE models (1980) had to minimize the number of nonlinear elements to minimize simulation time, all at the cost of accuracy. Today's models, thanks to the advancement of computing power, can increase the number of nonlinear elements and improve the accuracy of the models. The focus of this Application Note is to provide a method for developing a multi-stage SPICE model for low noise and low power operational amplifiers. The model presented, started with the work from Mark Alexander and Derek F. Bowers from Analog Devices (Appnote AN-138, 1990) [1]. The final model ended up with several key architectural changes that were required to model today's low noise, and low power precision amplifiers.

This application note provides a systematic process that simplifies the understanding of how to build an accurate straightforward SPICE model. This is accomplished by a model architecture that processes the input signal through several stages. The model parameters can easily be calculated using a hand calculator or Excel spreadsheet. The application note does not discuss the process of using SPICE, and assumes the user is familiar with this software.

The model presented in this application note is the ISL28127 single-pole 10MHz amplifier. The model enables the user to simulate important AC and DC parameters of an amplifier. For higher speed amplifiers, with multiple poles and zeros, reference AN-138 [1].

The AC parameters incorporated into the model are: 1/f and flat-band noise, slew rate, CMRR, gain and phase. The DC parameters are VOS, IOS, total supply current and output voltage swing. The model uses typical (+25°C) parameters given in the "Electrical Specifications" table of the data sheet [2].

### Introduction

The key to an accurate model is the input stage. The closer you model the input stage to the actual amplifier, the better your results. With only a few of the process parameters of the input stage transistors or MOSFETs, you can achieve very accurate AC representation of the amplifiers performance.

Another advantage of this model's architecture is the ability to model amplifiers with split supplies. There is no ground reference in any of the signal processing blocks. Instead, after the differential to single-ended conversion, all internally generated node voltages are referenced to the mid point of the supplies, much like the actual operation of an amplifier.

Discussed in this application note are the following topics:

1. The different cascaded stages of the SPICE Model:
  - Voltage Noise Stage
  - Input Stage
  - 1st Gain Stage
  - 2nd Gain Stage
  - Mid Supply Stage
  - Supply Isolation Stage
  - Common Mode Gain Stage
  - Output Stage
2. How the VCCS stages works
3. How the VCCS output stage works
4. Systematic process for calculating model parameters
5. Simulation results. Actual device vs simulation
6. Conclusions

### Cascaded Stages

Figure 1 is the schematic for the SPICE model and Figure 2 is the net list. Notice from the schematic, the only circuitry resembling an amplifier is the Input Stage. All other stages process the input signal with Voltage Controlled Current Sources (VCCS) and Voltage Controlled Voltage Sources (VCVS) along with diodes, DC supplies, simple resistors, capacitors and inductors.

The circuit schematic is built from eight different functional blocks. Each block is discussed in the following sections, with details of the blocks' functionality and design considerations.

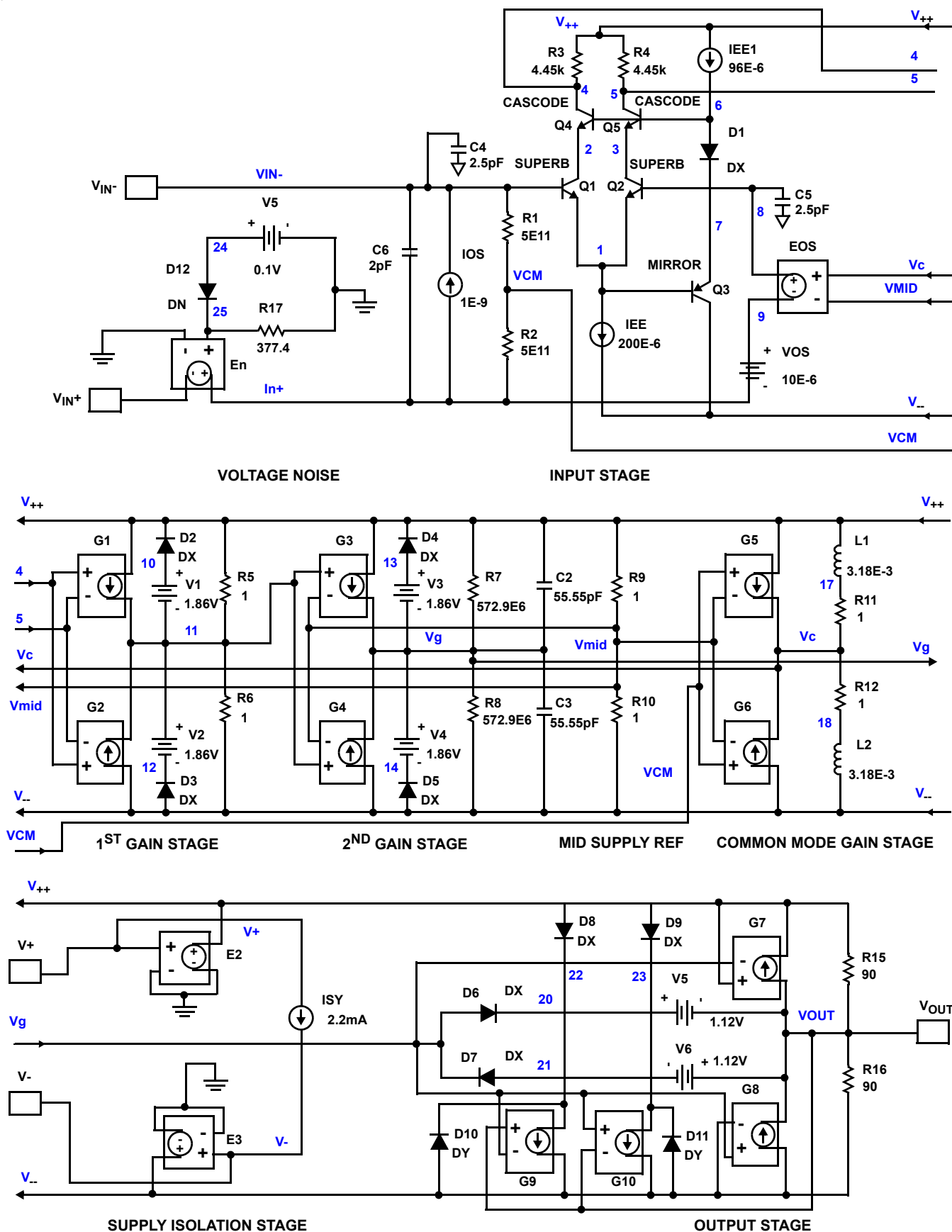

FIGURE 1. SPICE SCHEMATIC



### Voltage Noise Stage

The first stage in the model schematic, moving from left to right, is the Voltage Noise Stage. This stage generates the  $1/f$  and flat-band noise. To generate a flat-band voltage noise of a precision amplifier with only  $4\text{nV}/\sqrt{\text{Hz}}$ , all diodes and transistor model parameters  $k_f$  (flicker noise coefficient) and  $a_f$  (flicker noise exponent) need to be set to zero. To lower the noise floor of the model to single digit nanovolts, it may be necessary to reduce the network's Johnson noise [3] by reducing the resistance values where possible. Before reducing the resistor values, the process is to calculate the standard resistor values and complete all simulation tweaks. Once this is done, the last step is to tweak the Voltage Noise Stage by dropping the resistor values to  $1\Omega$  while recalculating the  $g_m$  and time constants of the stages to maintain the same transfer function for that stage. Resistors  $R_5$ ,  $R_6$ , and  $R_9$  thru  $R_{12}$  are resistors that can easily be set to  $1\Omega$ . For amplifiers with noise levels in the flat-band range of 100's of nV, reducing the network's Johnson noise may not be necessary. Initial noise simulations will tell you if this step is necessary. With the model's flat-band noise set below the amplifier's noise floor, the user can now adjust the  $1/f$  and flat-band noise with adjustments to  $DN$ ,  $R_{17}$  and  $V_5$ .

### Input Stage

The ISL28127 was selected for this application note to illustrate the level of accuracy obtainable by modeling an amplifiers exact input structure. The Input Stage of the ISL28127 consists of five bipolar transistors that model the actual device configuration, as shown in Figure 1. This however will not be the case for most SPICE models. Figure 3 and Figure 4 show typical NMOS and PMOS input stages, respectively.

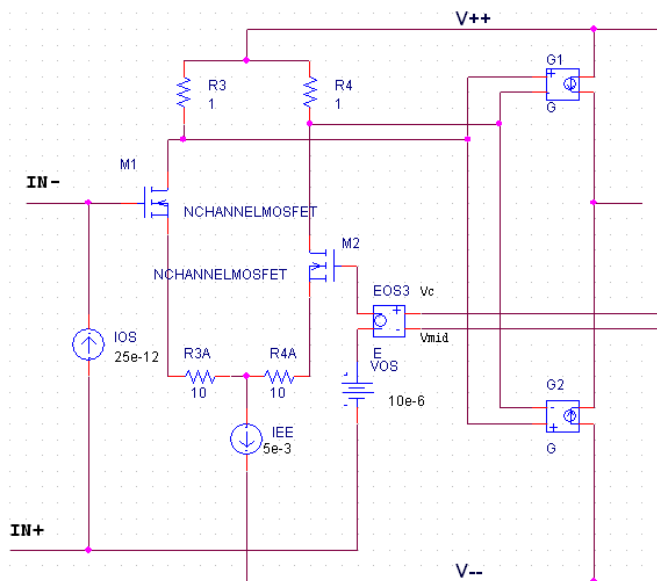

FIGURE 3. TYPICAL NMOS INPUT STAGE

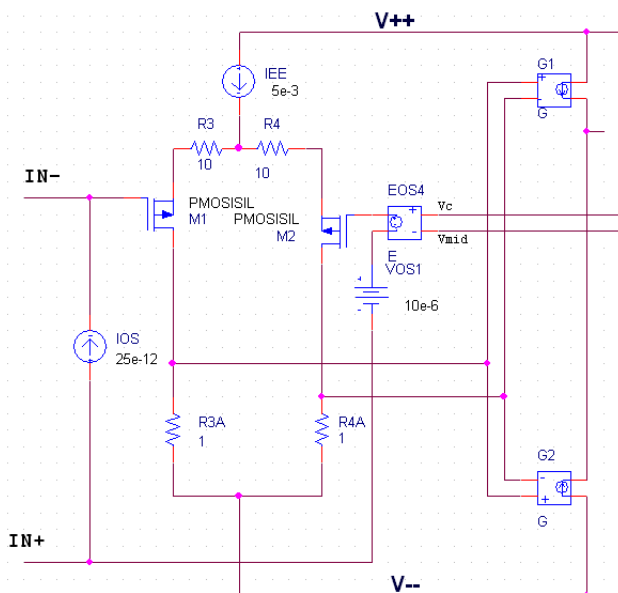

FIGURE 4. TYPICAL PMOS INPUT STAGE

The Input Stage can be configured with the same type of input device (NPN, PNP, P and N channel MOSFETs or J-FETS) as the physical op amp being modeled. The Input Stage includes a current supply to model IOS, a voltage supply to model VOS and a VCVS along with  $R_1$  and  $R_2$  to account for CMRR of the device.

### 1st Gain Stage

The purpose of the 1st Gain Stage is to set the combined gain of the Input Stage and the 1st Gain Stage to 1. Setting the combined gains to 1 simplifies the calculation to determine the slew-rate limiting components in the 2nd Gain Stage. Diodes  $D_2$  and  $D_3$  along with DC supplies  $V_1$  and  $V_2$  might be unnecessary, because their function is to clamp the output voltage swing and were going to do that in the next stage. We left them in because they're free. DC supply voltages  $V_1$  and  $V_2$  should be slightly larger than  $V_3$  and  $V_4$  in the 2nd Gain Stage. The thought is to limit most of the signal amplitude in the 1st stage and do the final amplitude tweak in the 2nd stage.

### 2nd Gain Stage

The 2nd Gain Stage is where the AVOL, bandwidth and slew-rate of the amplifier are set using  $G_3$ ,  $G_4$ ,  $R_7$ ,  $R_8$ ,  $C_2$  and  $C_3$ . Diodes  $D_4$  and  $D_5$  along with DC supplies  $V_3$  and  $V_4$  are used to set the maximum output voltage swing.

### Mid Supply Reference Stage

The Mid Supply Reference Stage is simply two equal resistors  $R_9$  and  $R_{10}$ . These resistors are used to generate a mid supply reference voltage. The resistor values are set to  $1\Omega$  to reduce the Johnson voltage noise of the model. The high current that flows through these resistors is transparent to the model user because of the Supply Isolation Stage, more free stuff.

### Common Mode Gain Stage

The Common Mode Gain Stage consists of two VCCS's that drive two equal resistors in series with an inductor connected to the supply rails. The inductors simulate the typical fall-off of CMRR that most amplifiers exhibit as the input frequency is increased. The current sources are controlled by the input common mode voltage (generated by resistors  $R_1$  and  $R_2$  in the Input Stage) relative to the mid supply voltage. Each control source has a  $g_m$  equal to the reciprocal of the associated resistor value divided by the CMRR of the amplifier at DC (Equation 10). The inductors add a zero to the common-mode gain, which is equivalent to adding a pole to the CMRR. The common-mode voltage, after being scaled and appropriately frequency shaped, is then added back into the Input Stage via the VCVS called EOS.

### Supply Isolation Stage

The Supply Isolation Stage consists of two VCVS's and a current source. This stage enables the user to program the total supply current of the amplifier with just one entry in the node list. It also isolates the internal supply currents from the external supply current seen by the user. This enables the model to provide the correct supply current for low power amplifiers with low voltage noise.

### Output Stage

The operation of the Output Stage is not entirely obvious. The amplifier's output signal, after receiving all the appropriate frequency shaping, appears as a voltage referenced to mid supply at the inputs to  $G_7$  and  $G_8$ .  $G_7$  and  $G_8$  drive two equal resistors connected to the supply rails and act as active current generators. Both  $G_7$  and  $G_8$  generate just enough current to provide the desired voltage drop across its parallel resistor. Refer to the section "How the VCCS Output Stage Works" on page 6.

When there is no load on the output, the model draws no current from either supply rail, thus behaving like an amplifier output. Simulating the right output resistance means the DC open loop gain will be properly reduced as the amplifier is loaded.

When a load is applied to the output, equal currents will be pulled from both supply rails. To make the output behave like a real amplifier,  $G_9$  and  $G_{10}$  force the appropriate amount of current to make it appear as if all the current is being sourced or sunk from the correct supply.

Output short circuit protection is provided by diodes  $D_6$  and  $D_7$  along with DC supplies  $V_5$  and  $V_6$ . Under fault conditions, the output voltage is clamped to the previous frequency shaping stage. The output short circuit current limit is determined by adjusting the value of  $V_5$  and  $V_6$ .

### How the VCCS Stage Works

When the voltage at the inputs to  $G_1$  and  $G_2$  (Figure 5) increases, the resultant voltage at the Midpoint will rise. Likewise, when the voltage at the inputs decrease, the midpoint voltage will decrease. If the  $g_m$  of the stage is

equal to the reciprocal of the parallel resistor, the stage has a positive unity gain.

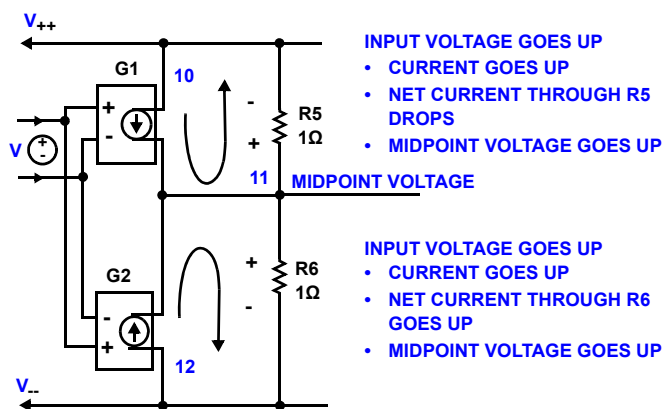

FIGURE 5. HOW THE VCCS WORKS

The single-ended equivalent circuit of Figure 5 is shown in Figure 6. The circuit shown in Figure 6 is sometimes easier to help visualize the signal flow through the stages.

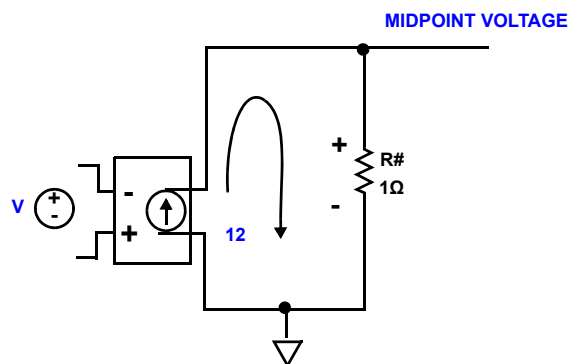
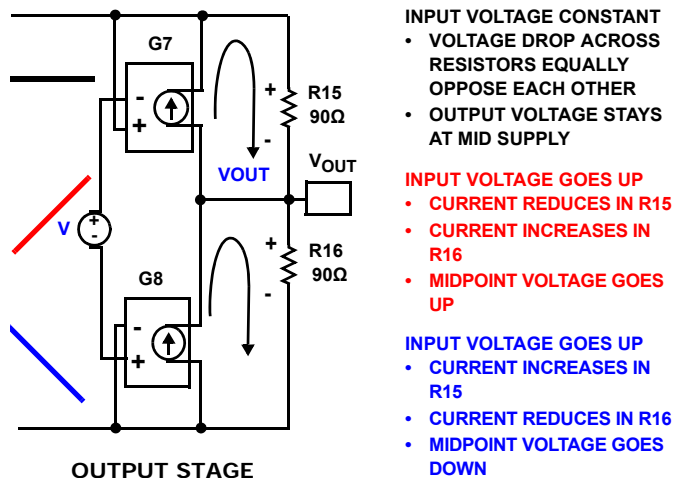

FIGURE 6. SINGLE-ENDED EQUIVALENT CIRCUIT TO FIGURE 5

## How the VCCS Output Stage Works

Figure 7 explains how the Output Stage works for a steady input voltage, an increasing input voltage and a decreasing input voltage.



OUTPUT STAGE

FIGURE 7. HOW THE VCCS OUTPUT STAGE WORKS

## A Systematic Process for Calculating Model Parameters

Table 1 is a list of the amplifiers parameters required to calculate the model parameters. The values shown in the table are for the ISL28127 model.

Once the values in Table 1 are determined, the model parameters given in Equations 1 through 15 can be calculated and put into the SPICE schematic.

TABLE 1. DEVICE PARAMETERS

| PARAMETER                     | VALUE  | UNITS | COMMENTS                          |
|-------------------------------|--------|-------|-----------------------------------|
| Quiescent Supply Current      | 2.2E-3 | A     |                                   |
| VCC                           | 15     | V     |                                   |
| VEE                           | -15    | V     |                                   |
| IEE                           | 200E-6 | A     | Differential input current source |
| Slew Rate                     | 3.6E6  | V/sec |                                   |
| Fp1                           | 5      | Hz    | Dominant Pole (Figure 8)          |
| AVOL                          | 2640E3 | V/V   | 128.43dB                          |
| VOS                           | 1E-5   | V     |                                   |
| IOS                           | 1E-9   | A     |                                   |
| Temperature                   | 25     | C     |                                   |
| Vt                            | 0.0257 | V     |                                   |
| Differential Input Resistance | 5E-11  | Ω     | Default value if unknown          |
| CMRR                          | 3.16E7 | V/V   | 150dB                             |

TABLE 1. DEVICE PARAMETERS (Continued)

| PARAMETER | VALUE | UNITS | COMMENTS         |
|-----------|-------|-------|------------------|
| Fcm       | 50    | Hz    | Common mode pole |
| Rout      | 45    | Ω     |                  |
| Isc       | 45    | mA    |                  |
| Voh       | 13.7  | V     | Vout max         |
| Vol       | -13.7 | V     | Vout max         |

The following equations will determine the model parameters for the SPICE schematic. Putting them into an Excel spreadsheet will enable the user to change critical specs and quickly see the effect on the op amp performance. The calculations are given for each stage of the model.

### Input Stage and Gain Stage Calculations

The process to set the Slew Rate and unity gain bandwidth, for a single pole stage, is accomplished in 3 steps:

- Determine the Capacitor value knowing IEE and the Slew Rate (Equation 1). This effectively sets the maximum frequency for the single pole RC network, and therefore the unity gain bandwidth.
- Determine the Resistor value knowing the dominant pole frequency (Equation 2). This effectively sets the break point for the RC network.
- Determine the  $g_m$  of the VCCS knowing the desired AVOL and R value of the RC network.

#### STEP 1

$$C_2 = C_3 = \frac{IEE}{SlewRate} \quad (EQ. 1)$$

$$C_2 = C_3 = \frac{200 \times 10^{-6}}{3.6 \times 10^{-6}} = 55.55 \text{ pF}$$

IEE is the value of the current source feeding the input differential pair (reference Figure 1). Under Slew Rate conditions, instantaneously all of this current is flowing through one side of the differential pair (until the feedback loop catches up). Equation 1 is used to calculate the capacitor value to set the Slew Rate of the model. Equation 1 is basically  $I_C = Cdv/dt$ , with Slew Rate equal to  $dv/dt$  and IEE equal to  $I_C$ .

Equation 2 calculates the value of the resistor for a set capacitor value of  $C_{2,3}$  and dominant pole frequency  $f_{p1}$ .

#### STEP 2

$$R_7 = R_8 = \frac{1}{2\pi f_{p1} C_{2,3}} \quad (EQ. 2)$$

$$R_7 = R_8 = \frac{1}{2\pi(5)(55.55 \text{ pF})} = 572.958 \text{ M}\Omega$$

Where  $f_{p1}$  = dominant pole (reference Figure 8).



Figure 8 shows the relationship of the unity gain bandwidth to the dominant pole frequency and AVOL.

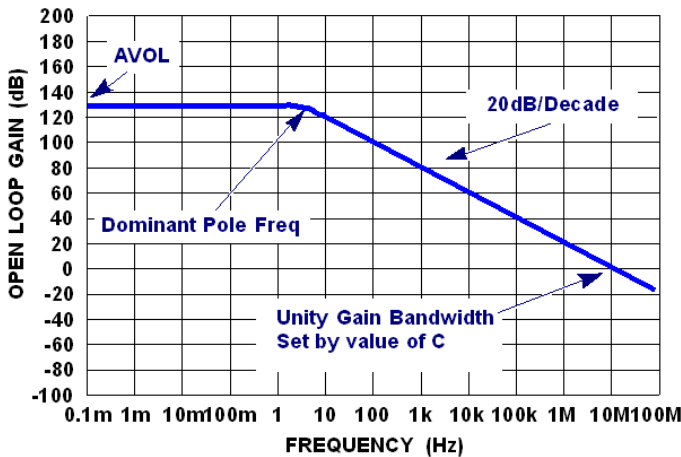

FIGURE 8. AVOL vs FREQUENCY

### STEP 3

$$G_3 = G_4 = \frac{AVOL}{R_{7,8}} \quad (EQ. 3)$$

$$G_3 = G_4 = \frac{2640 \times 10^6}{572.958 \times 10^6} = 4.6 \times 10^{-3}$$

Once again, the 1st Gain Stage is used to set the combined gain of the input stage and the 1st Gain Stage to 1. The voltage required at the input of  $G_3$  and  $G_4$  to cause  $200 \times 10^{-6}$  to flow through  $R_7$  and  $R_8$  is calculated in Equation 4.

$$g_m = \frac{I}{V} \Rightarrow V_{G_{3,4}} = \frac{I}{g_m} = \frac{200 \times 10^{-6}}{4.6 \times 10^{-3}} = 43.4 \text{ mV} \quad (EQ. 4)$$

During Slew Rate limit, the current through either resistor  $R_3$  or  $R_4$  will be clamped by the  $200 \times 10^{-6}$  current sink. Which resistor has the current depends upon the polarity of the input voltage (positive  $R_4$ , negative  $R_3$ ). This current will flow through the 4.45k $\Omega$  resistor resulting in a voltage drop of  $(200 \times 10^{-6}) \times (4.45 \text{ k}\Omega) = 890 \text{ mV}$ . This voltage drop appears at the input to  $G_1$  and  $G_2$ . In order to set the combined gain of the input stage and the 1st stage to one, we need to calculate the  $g_m$  of  $G_1$  and  $G_2$  so their output voltage equals 43.4mV (Equation 4) when 890mV is at their inputs. If we set the resistor value in parallel with the outputs of  $G_1$  and  $G_2$  to 1 $\Omega$ , then the voltage will equal the current and we can write Equation 5 to solve for the  $g_m$  of  $G_1$  and  $G_2$ .

$$G_1 = G_2 \Rightarrow g_m = \frac{I}{V} = \frac{43.4 \times 10^3}{890 \times 10^{-3}} = 48.77 \times 10^{-3} \quad (EQ. 5)$$

If the design review document is not available, set  $R_3$  and  $R_4$  to 1 $\Omega$  for the calculation of the voltage appearing at the inputs to  $G_1$  and  $G_2$ .

$$R_3 = R_4 = 4.45 \text{ k}\Omega \quad (\text{from design review}) \quad (EQ. 6)$$

Equations 7 and 8 are used to set  $V_1$  through  $V_4$  voltages for the maximum output voltage swing. The output voltage will be clamped at a voltage equal to  $V_{++} - (V_{1,3} + V_{D2,D4})$  for positive input voltage swings and  $V_{--} + (V_{2,4} + V_{D3,D5})$  for negative input voltage swings.

$$V_{1,3} = V_{CC} - (V_{OUTMAX}) + V_T \ln\left(\frac{2I_{EE}}{I_S}\right) \quad (EQ. 7)$$

$$V_{2,4} = (-V_{OUTMAX}) - V_{EE} + V_T \ln\left(\frac{2I_{EE}}{I_S}\right) \quad (EQ. 8)$$

Where  $V_T = 0.02585 \text{ V}$  at  $T = +25^\circ \text{C}$ .

$I_S = 1 \times 10^{-12} \text{ A}$  (for both diodes).

You can substitute some data sheet parameters directly into the model. These parameters are:

EOS = Input Offset Voltage (DC component only).

IOS = Input Offset Current.

$C_{diff}$  = Input differential capacitance (not shown in this model).

### Common-Mode Gain Stage

$$R_{11} = R_{12} = 1 \text{ M}\Omega \quad (EQ. 9)$$

$$G_7 = G_8 = \frac{1}{R_{11,12} \times CMRR} \quad (EQ. 10)$$

$$L_1 = L_2 = \frac{R_{11,12}}{2\pi f_p(cm)} \quad (EQ. 11)$$

Where  $f_{cm}$  is common-mode pole from the CMRR vs Frequency curve (similar to the dominant frequency pole shown in Figure 8).

### Output Stage

Setting the  $g_m$  equal to the reciprocal of  $2R_{OUT}$  results in unity gain through  $G_7$ - $G_{10}$ . The value of  $2R_{OUT}$  results from the need to have the output currents appear to be coming from one supply rail.

$$G_7 = G_8 = G_9 = G_{10} = \frac{1}{2R_{OUT}} \quad (EQ. 12)$$

$$R_{15} = R_{16} = 2 \times R_{OUT} \quad (EQ. 13)$$

$$V_3 = I_{SC}(0.764)R_{OUT} - V_T \ln\left(\frac{20 \times 10^6}{I_S}\right) \quad (EQ. 14)$$

$$V_4 = |I_{SC}(0.764)R_{OUT}| - V_T \ln\left(\frac{20 \times 10^6}{I_S}\right) \quad (EQ. 15)$$

### Simulation Results

Figures 9 through 14 compare actual device performance to simulation results. For a complete set of comparisons, reference the data sheet [2].

Characterization vs Simulation Results

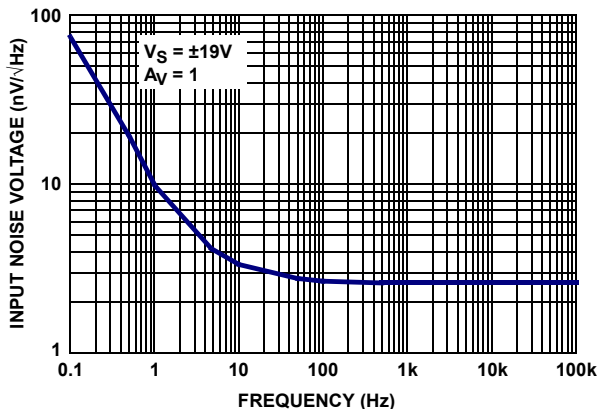

FIGURE 9. CHARACTERIZED INPUT NOISE VOLTAGE

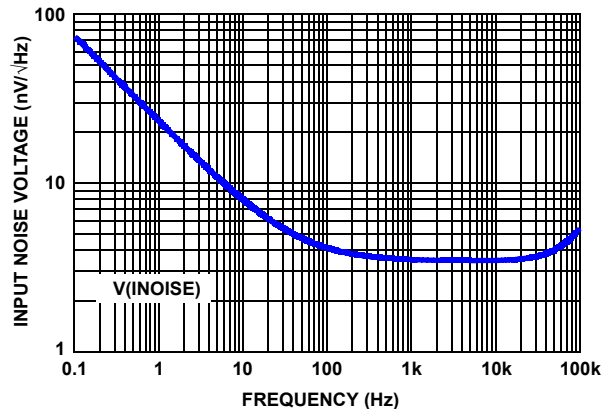

FIGURE 10. SIMULATED INPUT NOISE VOLTAGE

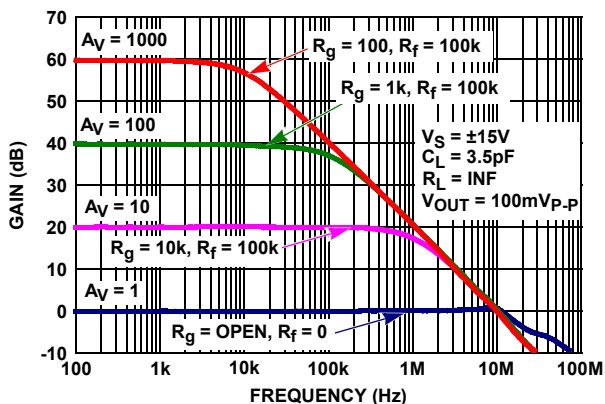

FIGURE 11. CHARACTERIZED CLOSED LOOP GAIN vs FREQUENCY

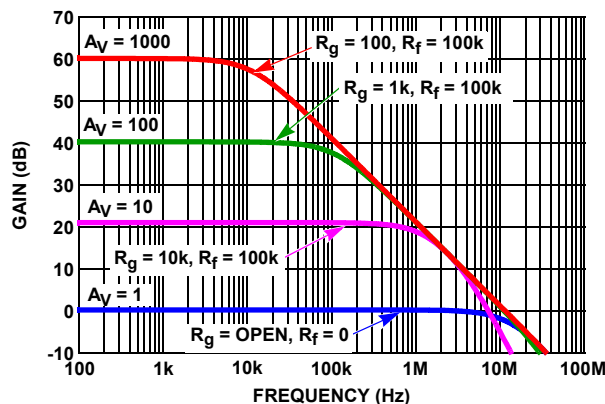

FIGURE 12. SIMULATED CLOSED LOOP GAIN vs FREQUENCY

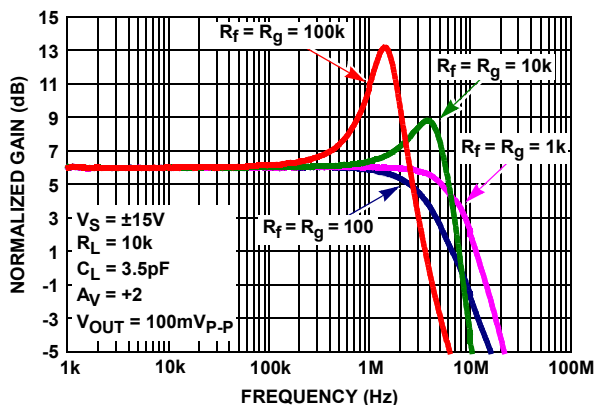

FIGURE 13. CHARACTERIZED CLOSED LOOP GAIN vs  $R_f/R_g$

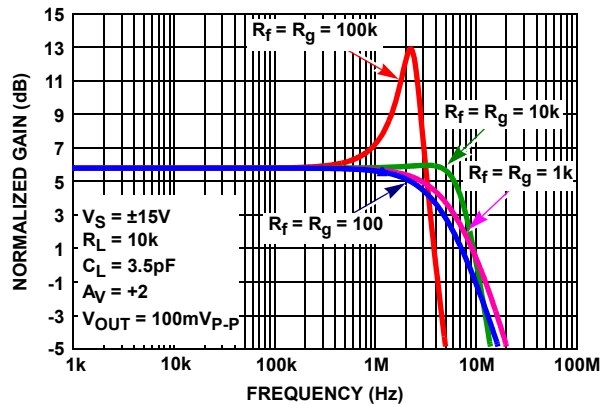

FIGURE 14. SIMULATED CLOSED LOOP GAIN vs  $R_f/R_g$



Characterization vs Simulation Results (Continued)

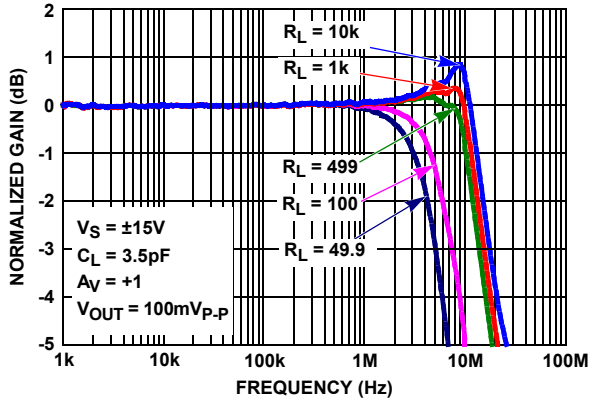

FIGURE 15. CHARACTERIZED CLOSED LOOP GAIN vs  $R_L$

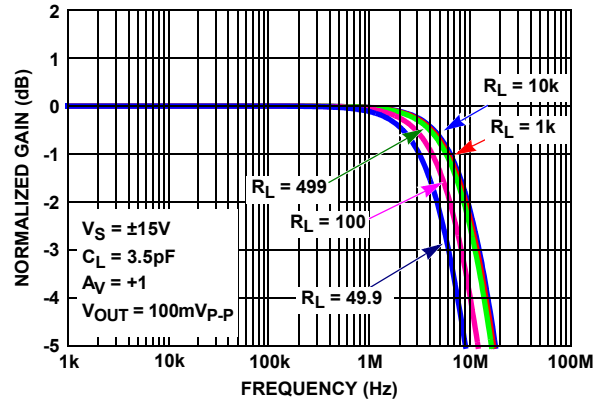

FIGURE 16. SIMULATED CLOSED LOOP GAIN vs  $R_L$

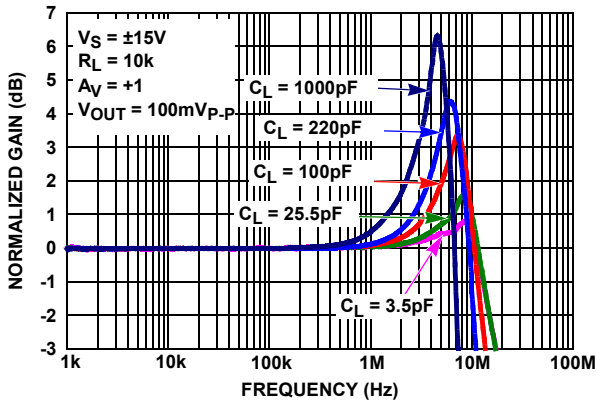

FIGURE 17. CHARACTERIZED CLOSED LOOP GAIN vs  $C_L$

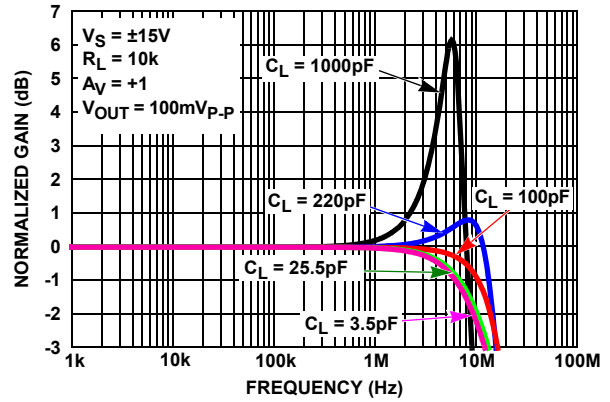

FIGURE 18. SIMULATED CLOSED LOOP GAIN vs  $C_L$

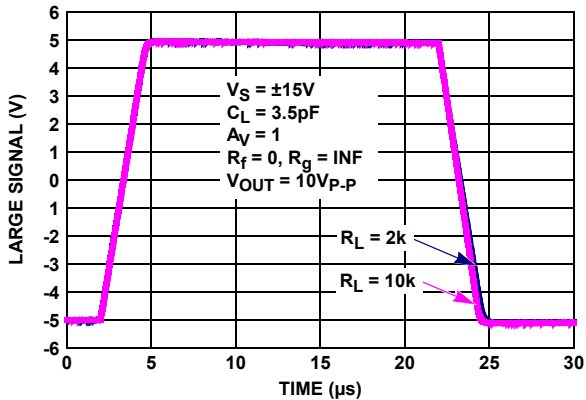

FIGURE 19. CHARACTERIZED LARGE SIGNAL 10V STEP RESPONSE

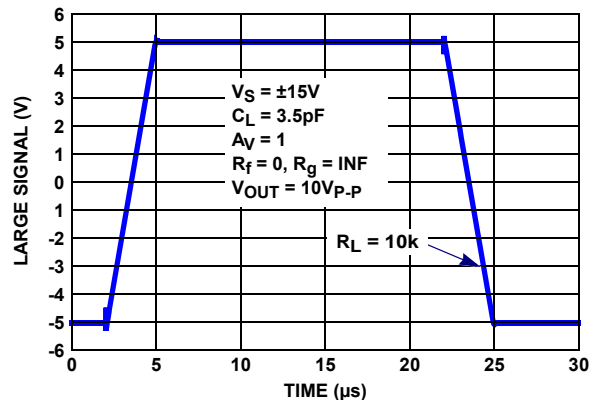

FIGURE 20. SIMULATED LARGE SIGNAL 10V STEP RESPONSE

## Characterization vs Simulation Results (Continued)

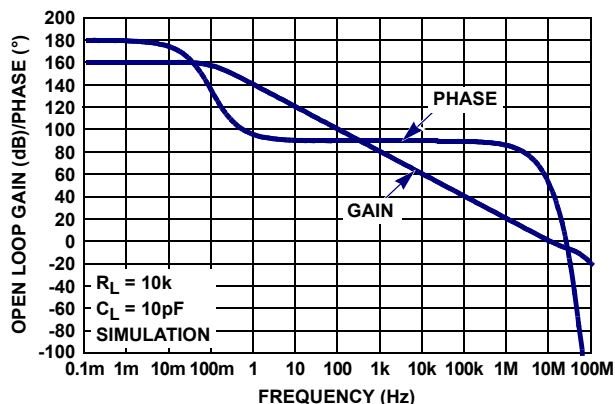

FIGURE 21. SIMULATED OPEN-LOOP GAIN, PHASE vs FREQUENCY

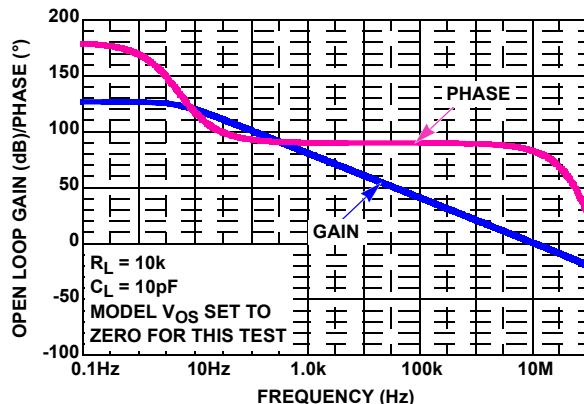

FIGURE 22. SIMULATED OPEN-LOOP GAIN, PHASE vs FREQUENCY

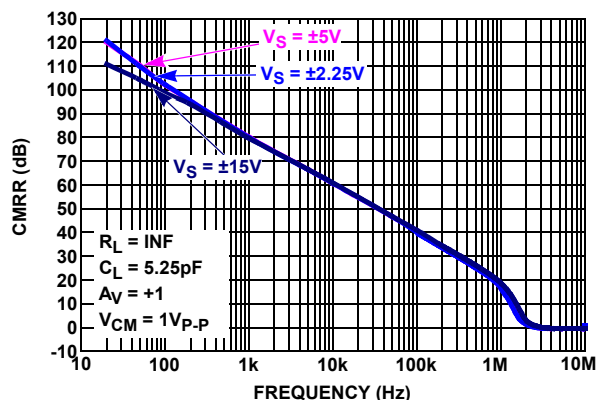

FIGURE 23. CHARACTERIZED CMRR vs FREQUENCY

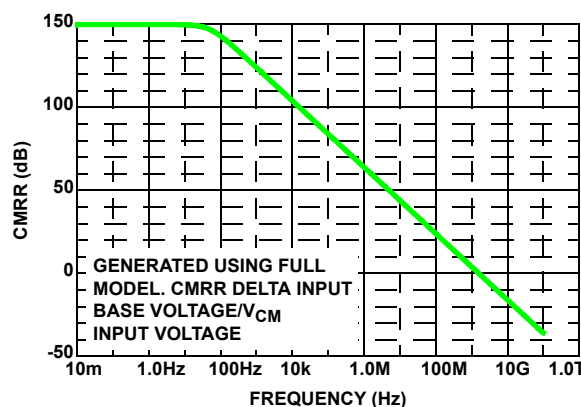

FIGURE 24. SIMULATED CMRR vs FREQUENCY

## Conclusions

This Application Note has presented a method for building an accurate straightforward SPICE model for today's low noise and low power precision amplifiers. The extremely close simulation to actual part comparison results was achieved by taking advantage of today's improved computing power and modeling 5 bipolar transistors with their specific model parameters for each type of transistor. Improvements to previous models include the ability to model single digit nanovolt noise parameters and very low total system supply currents for micro-powered amplifiers.

## Acknowledgment

I would like to thank Oscar Mansilla for all his help with the SPICE software, and especially his help with generating sub-circuits from a node list and building my own libraries in SPICE.

I would also like to thank Bob Pospisil for his technical expertise with op amps and helping me solve various problems along the way.

## References

- [1] Mark Alexander and Derek F. Bowers, Application Note AN-138, "SPICE-Compatible Op Amp Macro-Models", Analog Devices.
- [2] [ISL28127, ISL28227, ISL28227SEH data sheet](#)
- [3] Derek F. Bowers, IEEE 1989, "Minimizing Noise in Analog Bipolar Circuit Design", Precision Monolithics, Inc.

## Notice

1. Descriptions of circuits, software and other related information in this document are provided only to illustrate the operation of semiconductor products and application examples. You are fully responsible for the incorporation or any other use of the circuits, software, and information in the design of your product or system. Renesas Electronics disclaims any and all liability for any losses and damages incurred by you or third parties arising from the use of these circuits, software, or information.
2. Renesas Electronics hereby expressly disclaims any warranties against and liability for infringement or any other claims involving patents, copyrights, or other intellectual property rights of third parties, by or arising from the use of Renesas Electronics products or technical information described in this document, including but not limited to, the product data, drawings, charts, programs, algorithms, and application examples.
3. No license, express, implied or otherwise, is granted hereby under any patents, copyrights or other intellectual property rights of Renesas Electronics or others.
4. You shall not alter, modify, copy, or reverse engineer any Renesas Electronics product, whether in whole or in part. Renesas Electronics disclaims any and all liability for any losses or damages incurred by you or third parties arising from such alteration, modification, copying or reverse engineering.
5. Renesas Electronics products are classified according to the following two quality grades: "Standard" and "High Quality". The intended applications for each Renesas Electronics product depends on the product's quality grade, as indicated below.  
"Standard": Computers; office equipment; communications equipment; test and measurement equipment; audio and visual equipment; home electronic appliances; machine tools; personal electronic equipment; industrial robots; etc.  
"High Quality": Transportation equipment (automobiles, trains, ships, etc.); traffic control (traffic lights); large-scale communication equipment; key financial terminal systems; safety control equipment; etc.  
Unless expressly designated as a high reliability product or a product for harsh environments in a Renesas Electronics data sheet or other Renesas Electronics document, Renesas Electronics products are not intended or authorized for use in products or systems that may pose a direct threat to human life or bodily injury (artificial life support devices or systems; surgical implantations; etc.), or may cause serious property damage (space system; undersea repeaters; nuclear power control systems; aircraft control systems; key plant systems; military equipment; etc.). Renesas Electronics disclaims any and all liability for any damages or losses incurred by you or any third parties arising from the use of any Renesas Electronics product that is inconsistent with any Renesas Electronics data sheet, user's manual or other Renesas Electronics document.
6. When using Renesas Electronics products, refer to the latest product information (data sheets, user's manuals, application notes, "General Notes for Handling and Using Semiconductor Devices" in the reliability handbook, etc.), and ensure that usage conditions are within the ranges specified by Renesas Electronics with respect to maximum ratings, operating power supply voltage range, heat dissipation characteristics, installation, etc. Renesas Electronics disclaims any and all liability for any malfunctions, failure or accident arising out of the use of Renesas Electronics products outside of such specified ranges.
7. Although Renesas Electronics endeavors to improve the quality and reliability of Renesas Electronics products, semiconductor products have specific characteristics, such as the occurrence of failure at a certain rate and malfunctions under certain use conditions. Unless designated as a high reliability product or a product for harsh environments in a Renesas Electronics data sheet or other Renesas Electronics document, Renesas Electronics products are not subject to radiation resistance design. You are responsible for implementing safety measures to guard against the possibility of bodily injury, injury or damage caused by fire, and/or danger to the public in the event of a failure or malfunction of Renesas Electronics products, such as safety design for hardware and software, including but not limited to redundancy, fire control and malfunction prevention, appropriate treatment for aging degradation or any other appropriate measures. Because the evaluation of microcomputer software alone is very difficult and impractical, you are responsible for evaluating the safety of the final products or systems manufactured by you.
8. Please contact a Renesas Electronics sales office for details as to environmental matters such as the environmental compatibility of each Renesas Electronics product. You are responsible for carefully and sufficiently investigating applicable laws and regulations that regulate the inclusion or use of controlled substances, including without limitation, the EU RoHS Directive, and using Renesas Electronics products in compliance with all these applicable laws and regulations. Renesas Electronics disclaims any and all liability for damages or losses occurring as a result of your noncompliance with applicable laws and regulations.
9. Renesas Electronics products and technologies shall not be used for or incorporated into any products or systems whose manufacture, use, or sale is prohibited under any applicable domestic or foreign laws or regulations. You shall comply with any applicable export control laws and regulations promulgated and administered by the governments of any countries asserting jurisdiction over the parties or transactions.
10. It is the responsibility of the buyer or distributor of Renesas Electronics products, or any other party who distributes, disposes of, or otherwise sells or transfers the product to a third party, to notify such third party in advance of the contents and conditions set forth in this document.
11. This document shall not be reprinted, reproduced or duplicated in any form, in whole or in part, without prior written consent of Renesas Electronics.
12. Please contact a Renesas Electronics sales office if you have any questions regarding the information contained in this document or Renesas Electronics products.  
(Note 1) "Renesas Electronics" as used in this document means Renesas Electronics Corporation and also includes its directly or indirectly controlled subsidiaries.  
(Note 2) "Renesas Electronics product(s)" means any product developed or manufactured by or for Renesas Electronics.

(Rev.4.0-1 November 2017)



### SALES OFFICES

Renesas Electronics Corporation

<http://www.renesas.com>

Refer to "<http://www.renesas.com/>" for the latest and detailed information.

**Renesas Electronics America Inc.**  
1001 Murphy Ranch Road, Milpitas, CA 95035, U.S.A.  
Tel: +1-408-432-8888, Fax: +1-408-434-5351

**Renesas Electronics Canada Limited**  
9251 Yonge Street, Suite 8309 Richmond Hill, Ontario Canada L4C 9T3  
Tel: +1-905-237-2004

**Renesas Electronics Europe Limited**  
Dukes Meadow, Millboard Road, Bourne End, Buckinghamshire, SL8 5FH, U.K  
Tel: +44-1628-651-700, Fax: +44-1628-651-804

**Renesas Electronics Europe GmbH**  
Arcadiastrasse 10, 40472 Düsseldorf, Germany  
Tel: +49-211-6503-0, Fax: +49-211-6503-1327

**Renesas Electronics (China) Co., Ltd.**  
Room 1709 Quantum Plaza, No.27 ZhichunLu, Haidian District, Beijing, 100191 P. R. China  
Tel: +86-10-8235-1155, Fax: +86-10-8235-7679

**Renesas Electronics (Shanghai) Co., Ltd.**  
Unit 301, Tower A, Central Towers, 555 Langao Road, Putuo District, Shanghai, 200333 P. R. China  
Tel: +86-21-2226-0888, Fax: +86-21-2226-0999

**Renesas Electronics Hong Kong Limited**  
Unit 1601-1611, 16/F., Tower 2, Grand Century Place, 193 Prince Edward Road West, Mongkok, Kowloon, Hong Kong  
Tel: +852-2265-6688, Fax: +852-2886-9022

**Renesas Electronics Taiwan Co., Ltd.**  
13F, No. 363, Fu Shing North Road, Taipei 10543, Taiwan  
Tel: +886-2-8175-9600, Fax: +886-2-8175-9670

**Renesas Electronics Singapore Pte. Ltd.**  
80 Bendemeer Road, Unit #06-02 Hyflux Innovation Centre, Singapore 339949  
Tel: +65-6213-0200, Fax: +65-6213-0300

**Renesas Electronics Malaysia Sdn.Bhd.**  
Unit 1207, Block B, Menara Amcorp, Amcorp Trade Centre, No. 18, Jln Persiaran Barat, 46050 Petaling Jaya, Selangor Darul Ehsan, Malaysia  
Tel: +60-3-7955-9390, Fax: +60-3-7955-9510

**Renesas Electronics India Pvt. Ltd.**  
No.777C, 100 Feet Road, HAL 2nd Stage, Indiranagar, Bangalore 560 038, India  
Tel: +91-80-67208700, Fax: +91-80-67208777

**Renesas Electronics Korea Co., Ltd.**  
17F, KAMCO Yangjae Tower, 262, Gangnam-daero, Gangnam-gu, Seoul, 06265 Korea  
Tel: +82-2-558-3737, Fax: +82-2-558-5338